

---

TECHNICAL MANUAL

**UNIT, DIRECT SUPPORT, AND GENERAL  
SUPPORT MAINTENANCE MANUAL FOR  
INTERIM HIGH-MOBILITY ENGINEER  
EXCAVATOR (IHMEE)**

NSN 2420-66-148-7692

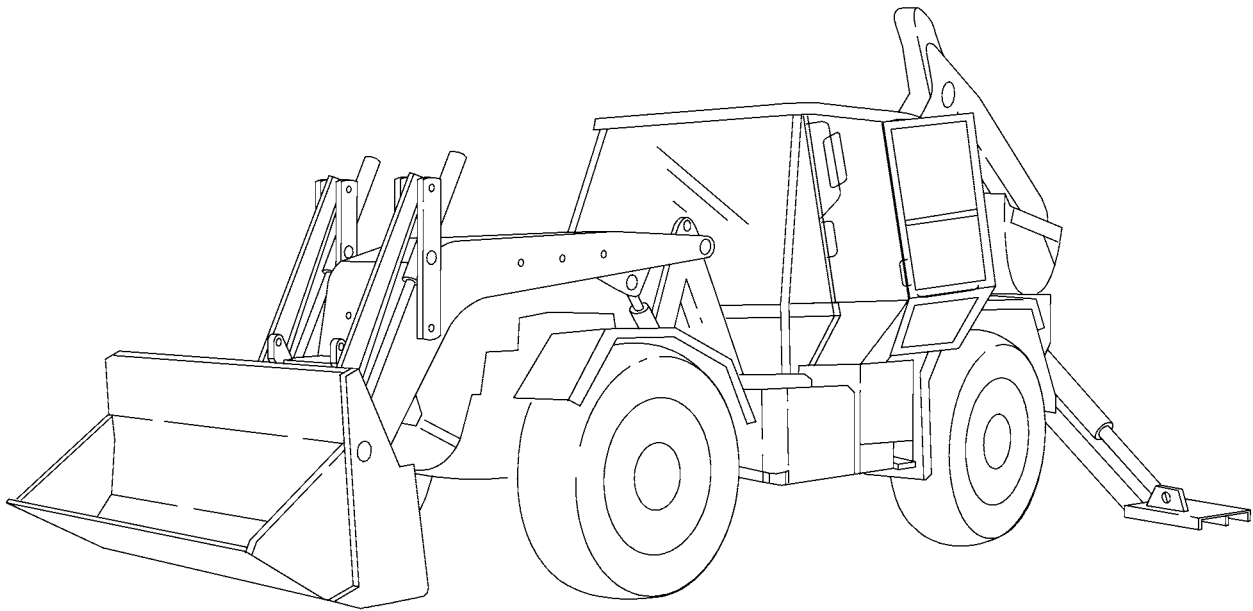

Approved for public release; distribution unlimited.



**WARNING**

Adhesives, solvents, and sealing compounds burn easily and give off vapors that are harmful to the skin and clothing. To avoid injury or death, keep away from open fire when using these materials, and use only in well-ventilated areas. If adhesives, solvents, or sealing compounds contact the skin or clothing, wash immediately with soap and water, and rinse thoroughly. Failure to comply may result in injury or death to personnel.

**WARNING**

Allow engine to cool before performing maintenance on the muffler, exhaust pipe, exhaust manifold, or turbocharger. If necessary, use insulated pads and gloves.

**WARNING**

Degreasing Solvent (MIL-PRF-680) is toxic and flammable. Keep away from heat or flame. Never smoke when using solvent. The flashpoint for Type II Degreasing Solvent is 141 °F (61 °C). Wear protective goggles, face shield, and gloves; use only in a well-ventilated area; avoid contact with skin, eyes, and clothes; and do not breathe vapors. Failure to comply may result in injury or death to personnel.

**WARNING**

Do not allow heavy components to swing while hanging by lifting device. Equipment may strike personnel and cause injury.

**WARNING**

Do not work on any item supported only by lift jacks or hoist. Always use blocks or proper stands to support the item prior to any work. Equipment may fall and cause serious injury or death to personnel.

**WARNING**

Do not work on fuel system when engine is hot; fuel can be ignited by a hot engine.

**WARNING**

Exercise extreme caution when working with acid, wear rubber apron to prevent clothing being damaged. Always wear safety goggles and rubber gloves and do not smoke when performing maintenance with acid tank. Acid can eat the skin. If acid contacts clothes, remove and flush with water. If acid contacts skin, immediately flush skin and get immediate medical attention. Failure to comply may result in injury or death to personnel.

**WARNING**

Exercise extreme caution when working near a cable or chain under tension. A snapped cable, shifting or swinging load may result in injury or death to personnel.

**WARNING**

Fuel and oil are slippery and can cause falls. To avoid injury, wipe up spilled fuel or oil with rags.

**WARNING**

If personnel become dizzy while using cleaning solvent, immediately get fresh air and medical help. If solvent contacts skin or clothes, flush with cold water. If solvent contacts eyes, immediately flush eyes with water and get immediate medical attention.

**WARNING**

If vehicle has recently been driven, oil may be hot. To avoid personal injury, wear appropriate safety equipment. Failure to comply may result in injury or death to personnel.

**WARNING**

Keep a fire extinguisher within easy reach when working with fuel or on a fuel system.

**WARNING**

Keep clear of equipment when equipment is being raised or lowered. Equipment may fall and cause serious injury or death to personnel.

**WARNING**

Never crawl under equipment when performing maintenance unless equipment is securely blocked. Equipment may fall and cause serious injury or death to personnel.

**WARNING**

No smoking, flames, sparks, or glowing or hot objects allowed within 50 ft. (15 m) of vehicle. Failure to comply may result in injury or death to personnel.

**WARNING**

To avoid personal injury, wear protective equipment when using compressed air. Failure to comply may result in injury or death to personnel.

**WARNING**

To prevent possible injury, wear gloves and protective eye equipment when handling fuel. Failure to comply may result in injury or death to personnel.

CHANGE  
NO. 1

HEADQUARTERS, DEPARTMENT OF THE ARMY  
WASHINGTON, D.C., 22 JUL 2005

## TECHNICAL MANUAL

# UNIT, DIRECT SUPPORT, AND GENERAL SUPPORT MAINTENANCE MANUAL FOR INTERIM HIGH-MOBILITY ENGINEER EXCAVATOR (IHMEE)

NSN 2420-66-148-7692

**Approved for public release; distribution unlimited.**

TM 5-2420-230-24-2, 01 OCT 2003, is updated as follows:

1. File this sheet in front of the manual for reference.
2. This change is mainly the result of updates made to ensure the accuracy and usability of the manual.
3. New or updated text is indicated by a vertical bar in the outer margin of the page.
4. Added or heavily revised illustrations are indicated by a vertical bar adjacent to it. Illustrations with minor changes are indicated by a miniature pointing hand indicating the updated area.
5. Remove old pages and insert new pages as indicated below.

### Remove Pages

A and B (Blank)  
i and ii  
L-1 through L-58  
FP-5/FP-6 blank through FP-37/FP-38 blank  
INDEX-1 through INDEX-10

### Insert Pages

A and B (Blank)  
i and ii  
L-1 through L-58  
FP-5/FP-6 blank through FP-37/FP-38 blank  
INDEX-1 through INDEX-12

By Order of the Secretary of the Army:

Official:



SANDRA R. RILEY  
*Administrative Assistant to the  
Secretary of the Army*

0517805

PETER J. SCHOOMAKER  
*General, United States Army  
Chief of Staff*

**DISTRIBUTION:** To be distributed in accordance with the initial distribution requirements for IDN: 256772, requirements for TM 5-2420-230-24-2.



INSERT LATEST UPDATED PAGES / WORK PACKAGES. DESTROY SUPERSEDED DATA.

**LIST OF EFFECTIVE PAGES / WORK PACKAGES**

NOTE: The portion of text affected by the changes is indicated by a vertical line in the outer margins of the page. Changes to illustrations are indicated by miniature pointing hands. Changes to wiring diagrams are indicated by shaded areas.

Dates of issue for original and changed pages / work packages are:

Original...0 ..... 01 OCT 2003

Change....1 ..... 22 JUL 2005

**TOTAL NUMBER OF PAGES FOR FRONT AND REAR MATTER IS 34 AND TOTAL NUMBER OF WORK PACKAGE PAGES IS 1502 CONSISTING OF THE FOLLOWING:**

<b>Page / WP No.</b>	<b>*Change No.</b>	<b>Page / WP No.</b>	<b>*Change No.</b>	<b>Page / WP No.</b>	<b>*Change No.</b>
Front Cover	0	FP-1 — FP-3/FP-4 (Blank)	0		
a and b	0	FP-5/FP-6 blank through FP-37/FP-38 blank	1		
A and B (Blank)	1				
i	1	FP39/FP-40 blank	0		
ii (Blank)	0	INDEX 1 — INDEX 12	1		
L-1	1				
L-2	0				
L-3	1				
L-4	0				
L-5	1				
L-6	0				
L-7 — L-17	1				
L-18	0				
L-19 — L-23	1				
L-24	0				
L-25 — L-34	1				
L-35	0				
L-36 — L-43	1				
L-44	0				
L-45 — L-55	1				
L-56	0				
L-57	1				
L-58 — L-1462	0				

\* Zero in this column indicates an original page or work package.





# UNIT, DIRECT SUPPORT, AND GENERAL SUPPORT MAINTENANCE MANUAL FOR INTERIM HIGH-MOBILITY ENGINEER EXCAVATOR (IHMEE)

NSN 2420-66-148-7692

## REPORTING ERRORS AND RECOMMENDING IMPROVEMENTS

You can help improve this publication. If you find any mistakes, or if you know of a way to improve the procedures, please let us know. Submit your DA Form 2028 (Recommended Changes to Publications and Blank Forms) through the Internet on the Army Electronic Product Support (AEPS) Web site. The Internet address is <https://aeps.ria.army.mil>. The DA Form 2028 is located under the Public Applications section in the AEPS Public Home Page. Fill out the form and click on SUBMIT. Using this form on the AEPS will enable us to respond quicker to your comments and better manage the DA Form 2028 program. You may also mail, fax, or e-mail your letter or DA Form 2028 directly to: AMSTA-LC-LMIT / TECH PUBS, TACOM-RI, 1 Rock Island Arsenal, Rock Island, IL 61299-7630. The e-mail address is TACOM-TECH-PUBS@ria.army.mil. The fax number is (DSN) 793-0726 or Commercial (309) 782-0726.

**Approved for public release; distribution unlimited.**

## Table of Contents

	<b>Page</b>
APPENDIX L Engine Service and Troubleshooting Manuals . . . . .	L-1
Section I U.S. Army Supplement to Cummins Material. . . . .	L-2
Section II Vendor Service Manual. . . . .	L-59
Section III Vendor Troubleshooting Manual. . . . .	L-536
Power Distribution Panel Layout . . . . .	FP-1
Power Distribution Panel Diagram. . . . .	FP-3
Electric Diagram . . . . .	FP-23
Hydraulic Diagram . . . . .	FP-37
Pneumatic Diagram . . . . .	FP-39



## APPENDIX L

### ENGINE SERVICE AND TROUBLESHOOTING MANUALS

<b>Contents</b>	<b>Para</b>	<b>Page</b>
Scope.....	L-1	L-2
General.....	L-2	L-2
Engine Repair.....	L-3	L-3
Steam Cleaning the Engine.....	L-4	L-4
Engine Mounting.....	L-5	L-5
Engine Repair (Rear Lifting Bracket Replacement).....	L-6	L-7
Engine Repair (Fan Pulley Replacement).....	L-7	L-8
Engine Repair (Vibration Damper/Crankshaft Pulley Replacement).....	L-8	L-9
Engine Repair (Belt Tensioner Replacement).....	L-9	L-10
Engine Repair (Fan Hub Replacement).....	L-10	L-11
Engine Repair (Thermostat Replacement).....	L-11	L-12
Turbocharger Replacement.....	L-12	L-13
Exhaust Manifold Replacement.....	L-13	L-15
Engine Repair (Fuel Lines Replacement).....	L-14	L-16
Engine Repair (Dipstick Replacement).....	L-15	L-18
Aftercooler Replacement.....	L-16	L-19
Valve Cover Replacement.....	L-17	L-21
Injector Nozzles Replacement.....	L-18	L-22
Engine Repair (Rocker Levers Replacement).....	L-19	L-23
Engine Repair (Push Rods Replacement).....	L-20	L-24
Cylinder Head Maintenance.....	L-21	L-25
Engine Repair (Front Cover Replacement).....	L-22	L-27
Water Pump Replacement.....	L-23	L-28
Flywheel Replacement.....	L-24	L-29
Flywheel Housing Replacement.....	L-25	L-30
Injection Pump Replacement.....	L-26	L-31
Fuel Transfer Pump Replacement.....	L-27	L-32
Engine Repair (Tappet Cover Replacement).....	L-28	L-33
Engine Oil Cooler Replacement.....	L-29	L-34
Engine Repair (Water Inlet Connection Replacement).....	L-30	L-35
Oil Pan Replacement.....	L-31	L-36
Suction Tube Replacement.....	L-32	L-37
Engine Repair (Rear Seal Housing Replacement).....	L-33	L-38
Camshaft Replacement.....	L-34	L-39
Engine Repair (Valve Tappets Replacement).....	L-35	L-41
Oil Pump Replacement.....	L-36	L-42
Engine Repair (Gear Housing Replacement).....	L-37	L-43
Piston and Rod Assemblies Replacement.....	L-38	L-45
Crankshaft Replacement.....	L-39	L-46
Cylinder Block Repair.....	L-40	L-47
Engine Repair (Crankshaft Gear Replacement).....	L-41	L-49
Engine Repair (Camshaft Gear Replacement).....	L-42	L-50
Cylinder Head Repair.....	L-43	L-51
Engine Repair (Rocker Lever Repair).....	L-44	L-53
Engine Oil Cooler Repair.....	L-45	L-54
Engine Repair (Fan Hub Maintenance).....	L-46	L-55

Contents	Para	Page
Engine Repair (Turbocharger Mounting Stud Replacement) . . . . .	L-47	L-56
Engine Repair (Mechanical Tachometer Drive Cover Replacement) . . . . .	L-48	L-57
Idle Adjustment . . . . .	L-49	L-58

## Section I. U.S. Army Supplement to Cummins Material.

### L-1. SCOPE.

This appendix contains information for servicing the engine. Section I contains U.S. Army supplemental information to the vendor manual. The supplemental information includes initial setup task boxes for all maintenance tasks covered in the vendor manual that apply to the IHMEE. The supplemental information also includes individual task headings and page references to aid in locating the tasks in the vendor manual.

Section II contains the manufacturer's technical manual. This manual is unedited and covers multiple models of Cummins engines. This manual also contains parts information for Cummins engines. Refer to Para L-2 for details on how to use this material.

Section III is the manufacturer's troubleshooting manual. This manual is unedited and covers multiple models of Cummins engines. Refer to Para L-2 for details on how to use this material.

### L-2. GENERAL.

To perform a task covered in this appendix, refer to the task box for initial setup information as you would with a normal maintenance procedure. The individual task headings have page references to aid in locating the tasks in the vendor manual. Most pages will also include two different page numbers. The appendix page number will have the appendix letter and a page number like the one at the bottom of this page. This page number will be used in all references made in Section I. The other page number is the vendor material page numbering. It will be used for any references made within the vendor material.

The IHMEE uses the Cummins 6 cylinder 6BT5.9 engine. All information in Section II and Section III that does not pertain to the 6BT5.9 engine and all parts information should be ignored. Refer to TM 5-2420-230-24P for parts information.



**L-4. STEAM CLEANING THE ENGINE.**

This Task Covers:

- a. Servicing
- b. Follow-On Maintenance

**INITIAL SETUP**

<i>Test Equipment</i> None	<i>Equipment Conditions</i> <i>TM or Para</i> TM 5-2420-230-10	<i>Condition Description</i> Vehicle positioned on level ground.
<i>Tools and Special Tools</i> Tool kit, common no. 2, Item 36, Appendix B	TM 5-2420-230-10	Parking brake applied.
<i>Materials/Parts</i> None	TM 5-2420-230-10	Engine shut OFF.
<i>Personnel Required</i> MOS 62B, Construction Equipment Repairer	TM 5-2420-230-10	Electrical master switch OFF. “Do Not Operate” tag attached to ignition switch.
<i>References</i> None	<i>Drawings Required</i> None	Hood raised.
		<i>Estimated Time to Complete</i> Refer to MAC in Appendix B

**a. Servicing.**

Refer to page L-97 for steam cleaning.

**b. Follow-On Maintenance.**

- (1) Start engine and perform functional test (TM 5-2420-230-10).
- (2) Shut OFF engine (TM 5-2420-230-10).
- (3) Close engine hood and attach clips (TM 5-2420-230-10).
- (4) Remove “Do Not Operate” tag from ignition switch (TM 5-2420-230-10).

**END OF TASK**

**L-5. ENGINE MOUNTING.**

This Task Covers:

a. Mounting

b. Dismounting

c. Follow-On Maintenance

**INITIAL SETUP**

*Test Equipment*  
None

*References*  
None

*Tools and Special Tools*  
Tool kit, common no. 2, Item 36, Appendix B  
Field maintenance, basic, Item 23, Appendix B  
Lifting equipment, suitable

*Equipment Conditions*  
*TM or Para*      *Condition Description*  
Para 4-10      Engine separated from transmission.

*Materials/Parts*  
Nut, self-locking, Item 112, Appendix D (4)

*Drawings Required*  
TM 5-2420-230-24P      Figure 23

*Personnel Required*  
MOS 62B, Construction Equipment Repairer (2)

*Estimated Time to Complete*  
Refer to MAC in Appendix B

**a. Mounting.**

**WARNING**

- Never crawl under equipment when performing maintenance unless equipment is securely blocked. Equipment may fall and cause serious injury or death to personnel.
- Keep clear of equipment when equipment is being raised or lowered. Equipment may fall and cause serious injury or death to personnel.
- Do not work on any item supported only by lift jacks or hoist. Always use blocks or proper stands to support the item prior to any work. Equipment may fall and cause serious injury or death to personnel.
- Do not allow heavy components to swing while hanging by lifting device. Equipment may strike personnel and cause injury.
- Exercise extreme caution when working near a cable or chain under tension. A snapped cable, shifting or swinging load may result in injury or death to personnel.

Refer to page L-97 to mount the engine.

***b. Dismounting.***

**WARNING**

- Never crawl under equipment when performing maintenance unless equipment is securely blocked. Equipment may fall and cause serious injury or death to personnel.
- Keep clear of equipment when equipment is being raised or lowered. Equipment may fall and cause serious injury or death to personnel.
- Do not work on any item supported only by lift jacks or hoist. Always use blocks or proper stands to support the item prior to any work. Equipment may fall and cause serious injury or death to personnel.
- Do not allow heavy components to swing while hanging by lifting device. Equipment may strike personnel and cause injury.
- Exercise extreme caution when working near a cable or chain under tension. A snapped cable, shifting, or swinging load may result in injury or death to personnel.

Refer to page L-202 to dismount the engine.

***c. Follow-On Maintenance.***

Connect engine to transmission (Para 4-10).

**END OF TASK**







**L-8. ENGINE REPAIR (VIBRATION DAMPER/CRANKSHAFT PULLEY REPLACEMENT).**

This Task Covers:

- |                 |                          |               |
|-----------------|--------------------------|---------------|
| a. Removal      | b. Cleaning              | c. Inspection |
| d. Installation | e. Follow-On Maintenance |               |

**INITIAL SETUP**

<i>Test Equipment</i> None	<i>References</i> None
<i>Tools and Special Tools</i> Tool kit, common no. 2, Item 36, Appendix B Tool kit, general mechanics, Item 38, Appendix B	<i>Equipment Conditions</i> <i>TM or Para</i> Para 4-6 Para 9-6 <i>Condition Description</i> Drive belt removed. Hydraulic fan motor removed.
<i>Materials/Parts</i> Developer, spot checker, Item 36, Appendix C Solution, soap, Item 56, Appendix C Solvent, degreasing, Item 58, Appendix C	<i>Drawings Required</i> TM 5-2420-230-24P Figure 9
<i>Personnel Required</i> MOS 62B, Construction Equipment Repairer	<i>Estimated Time to Complete</i> Refer to MAC in Appendix B

**a. Removal.**

Refer to page L-99 for removal.

**b. Cleaning.**

**WARNING**

- Degreasing Solvent (MIL-PRF-680) is toxic and flammable. Keep away from heat or flame. Never smoke when using solvent. The flashpoint for Type II Degreasing Solvent is 141 °F (61 °C). Wear protective goggles, face shield, and gloves; use only in a well-ventilated area; avoid contact with skin, eyes, and clothes; and do not breathe vapors. Failure to comply may result in injury or death to personnel.
- If personnel become dizzy while using cleaning solvent, immediately get fresh air and medical help. If solvent contacts skin or clothes, flush with cold water. If solvent contacts eyes, immediately flush eyes with water and get immediate medical attention.
- Adhesives, solvents, and sealing compounds burn easily and give off vapors that are harmful to the skin and clothing. To avoid injury or death, keep away from open fire when using these materials, and use only in well-ventilated areas. If adhesives, solvents, or sealing compounds contact the skin or clothing, wash immediately with soap and water, and rinse thoroughly. Failure to comply may result in injury or death to personnel.

Refer to page L-242 for cleaning.

**c. Inspection.**

Refer to page L-242 for inspection.

**d. Installation.**

Refer to page L-199 for installation.

**e. Follow-On Maintenance.**

- (1) Install drive belt (Para 4-6).
- (2) Install hydraulic fan motor (Para 9-6).

**END OF TASK**

**L-9. ENGINE REPAIR (BELT TENSIONER REPLACEMENT).**

This Task Covers:

- a. Removal
- b. Inspection
- c. Installation
- d. Follow-On Maintenance

**INITIAL SETUP**

*Test Equipment*  
None

*References*  
None

*Tools and Special Tools*  
Tool kit, common no. 2, Item 36, Appendix B  
Tool kit, general mechanics, Item 38, Appendix B

*Equipment Conditions*  
*TM or Para*      *Condition Description*  
Para 4-6      Drive belt removed.

*Materials/Parts*  
None

*Drawings Required*  
TM 5-2420-230-24P Figure 8

*Personnel Required*  
MOS 62B, Construction Equipment Repairer

*Estimated Time to Complete*  
Refer to MAC in Appendix B

**a. Removal.**

Refer to page L-99 for removal.

**b. Inspection.**

Refer to page L-399 for inspection.

**c. Installation.**

Refer to page L-200 for installation.

**d. Follow-On Maintenance.**

Install drive belt (Para 4-6).

**END OF TASK**

**L-10. ENGINE REPAIR (FAN HUB REPLACEMENT).**

This Task Covers:

- a. Removal
- b. Inspection
- c. Installation
- d. Follow-On Maintenance

**INITIAL SETUP**

*Test Equipment*  
None

*References*  
None

*Tools and Special Tools*  
Tool kit, common no. 2, Item 36, Appendix B  
Tool kit, general mechanics, Item 38, Appendix B

*Equipment Conditions*  
*TM or Para*      *Condition Description*  
Para 4-6      Drive belt removed.

*Materials/Parts*  
None

*Drawings Required*  
TM 5-2420-230-24P Figure 7

*Personnel Required*  
MOS 62B, Construction Equipment Repairer

*Estimated Time to Complete*  
Refer to MAC in Appendix B

**a. Removal.**

Refer to page L-100 for removal.

**b. Inspection.**

Refer to page L-396 for inspection.

**c. Installation.**

Refer to page L-199 for installation.

**d. Follow-On Maintenance.**

Install drive belt (Para 4-6).

**END OF TASK**

**L-11. ENGINE REPAIR (THERMOSTAT REPLACEMENT).**

This Task Covers:

- |            |                          |                 |
|------------|--------------------------|-----------------|
| a. Removal | b. Inspection            | c. Installation |
| d. Testing | e. Follow-On Maintenance |                 |

**INITIAL SETUP**

*Test Equipment*  
None

*References*  
None

*Tools and Special Tools*  
Tool kit, common no. 2, Item 36, Appendix B  
Tool kit, general mechanics, Item 38, Appendix B

*Equipment Conditions*  
*TM or Para*      *Condition Description*  
Para 9-4      Cooling system drained.

*Materials/Parts*  
Gasket, Item 87, Appendix D

*Drawings Required*  
TM 5-2420-230-24P Figure 28

*Personnel Required*  
MOS 62B, Construction Equipment Repairer

*Estimated Time to Complete*  
Refer to MAC in Appendix B

**a. Removal.**

Refer to page L-101 for removal.

**b. Inspection.**

Refer to page L-402 for inspection.

**c. Installation.**

Refer to page L-198 for installation.

**d. Testing.**

Refer to page L-402 for testing.

**e. Follow-On Maintenance.**

Refill cooling system (Para 9-4).

**END OF TASK**

**L-12. TURBOCHARGER REPLACEMENT.**

This Task Covers:

- |                 |                          |               |
|-----------------|--------------------------|---------------|
| a. Removal      | b. Cleaning              | c. Inspection |
| d. Installation | e. Follow-On Maintenance |               |

**INITIAL SETUP**

*Test Equipment*  
None

*Personnel Required*  
MOS 62B, Construction Equipment Repairer

*Tools and Special Tools*  
Tool kit, common no. 2, Item 36, Appendix B  
Tool kit, general mechanics, Item 38, Appendix B

*References*  
None

*Materials/Parts*  
Antiseize compound, Item 12, Appendix C  
Oil, lubricating, OE/HDO 30, Item 44, Appendix C  
Adhesive, sealant, Item 25, Appendix C  
Solvent, degreasing, Item 58, Appendix C  
Gasket, Item 62, Appendix D  
Gasket, Item 76, Appendix D

*Equipment Conditions*  
*TM or Para*      *Condition Description*  
TM 5-2420-230-10      Hood raised.

*Drawings Required*  
TM 5-2420-230-24P      Figure 39  
TM 5-2420-230-24P      Figure 40

*Estimated Time to Complete*  
Refer to MAC in Appendix B

**a. Removal.**

**WARNING**

Allow engine to cool before performing maintenance on the muffler, exhaust pipe, exhaust manifold, or turbocharger. If necessary, use insulated pads and gloves.

Refer to page L-101 for removal.

**b. Cleaning.****WARNING**

- Degreasing Solvent (MIL-PRF-680) is toxic and flammable. Keep away from heat or flame. Never smoke when using solvent. The flashpoint for Type II Degreasing Solvent is 141 °F (61 °C). Wear protective goggles, face shield, and gloves; use only in a well-ventilated area; avoid contact with skin, eyes, and clothes; and do not breathe vapors. Failure to comply may result in injury or death to personnel.
- If personnel become dizzy while using cleaning solvent, immediately get fresh air and medical help. If solvent contacts skin or clothes, flush with cold water. If solvent contacts eyes, immediately flush eyes with water and get immediate medical attention.
- Adhesives, solvents, and sealing compounds burn easily and give off vapors that are harmful to the skin and clothing. To avoid injury or death, keep away from open fire when using these materials, and use only in well-ventilated areas. If adhesives, solvents, or sealing compounds contact the skin or clothing, wash immediately with soap and water, and rinse thoroughly. Failure to comply may result in injury or death to personnel.
- To avoid personal injury, wear protective equipment when using compressed air. Failure to comply may result in injury or death to personnel.

Refer to page L-414 for cleaning.

**c. Inspection.**

Refer to page L-414 for inspection.

**d. Installation.****WARNING**

Adhesives, solvents, and sealing compounds burn easily and give off vapors that are harmful to the skin and clothing. To avoid injury or death, keep away from open fire when using these materials, and use only in well-ventilated areas. If adhesives, solvents, or sealing compounds contact the skin or clothing, wash immediately with soap and water, and rinse thoroughly. Failure to comply may result in injury or death to personnel.

Refer to page L-195 for installation.

**e. Follow-On Maintenance.**

Close engine hood and attach clips (TM 5-2420-230-10).

**END OF TASK**



**L-13. EXHAUST MANIFOLD REPLACEMENT.**

This Task Covers:

- a. Removal
- b. Inspection
- c. Installation
- d. Follow-On Maintenance

**INITIAL SETUP**

*Test Equipment*  
None

*References*  
None

*Tools and Special Tools*  
Tool kit, common no. 2, Item 36, Appendix B  
Tool kit, general mechanics, Item 38, Appendix B

*Equipment Conditions*  
*TM or Para*      *Condition Description*  
Para L-12      Turbocharger removed.

*Materials/Parts*  
Antiseize compound, Item 12, Appendix C  
Gasket, Item 69, Appendix D (6)

*Drawings Required*  
TM 5-2420-230-24P Figure 12

*Personnel Required*  
MOS 62B, Construction Equipment Repairer

*Estimated Time to Complete*  
Refer to MAC in Appendix B

**a. Removal.**

**WARNING**

Allow engine to cool before performing maintenance on the muffler, exhaust pipe, exhaust manifold, or turbocharger. If necessary, use insulated pads and gloves.

Refer to page L-103 for removal.

**b. Inspection.**

Refer to page L-423 for inspection.

**c. Installation.**

**WARNING**

Adhesives, solvents, and sealing compounds burn easily and give off vapors that are harmful to the skin and clothing. To avoid injury or death, keep away from open fire when using these materials, and use only in well-ventilated areas. If adhesives, solvents, or sealing compounds contact the skin or clothing, wash immediately with soap and water, and rinse thoroughly. Failure to comply may result in injury or death to personnel.

Refer to page L-194 for installation.

**d. Follow-On Maintenance.**

Install turbocharger (Para L-12).

**END OF TASK**

**L-14. ENGINE REPAIR (FUEL LINES REPLACEMENT).**

This Task Covers:

- |                 |                          |               |
|-----------------|--------------------------|---------------|
| a. Removal      | b. Cleaning              | c. Inspection |
| d. Installation | e. Follow-On Maintenance |               |

**INITIAL SETUP**

*Test Equipment*  
None

*Personnel Required*  
MOS 62B, Construction Equipment Repairer

*Tools and Special Tools*  
Tool kit, common no. 2, Item 36, Appendix B  
Tool kit, general mechanics, Item 38, Appendix B

*References*  
None

*Materials/Parts*  
Solvent, degreasing, Item 58, Appendix C  
Seal, banjo connect, Item 238, Appendix D (6)  
Washer, locking, Item 287, Appendix D

*Equipment Conditions*  
*TM or Para*      *Condition Description*  
TM 5-2420-230-10      Hood raised.

*Drawings Required*  
TM 5-2420-230-24P      Figure 33

*Estimated Time to Complete*  
Refer to MAC in Appendix B

**a. Removal.**

**WARNING**

- No smoking, flames, sparks, or glowing or hot objects allowed within 50 ft. (15 m) of vehicle. Failure to comply may result in injury or death to personnel.
- To prevent possible injury, wear gloves and protective eye equipment when handling fuel. Failure to comply may result in injury or death to personnel.
- Keep a fire extinguisher within easy reach when working with fuel or on a fuel system.
- Do not work on fuel system when engine is hot; fuel can be ignited by a hot engine.

- (1) Remove injection pump supply line (1) from injection pump (2).

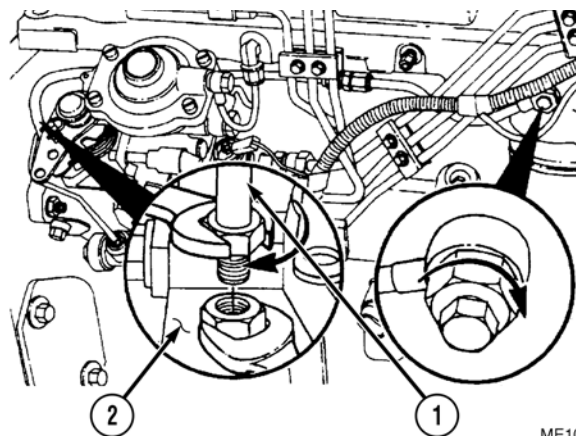

ME1038

- (2) Remove injection pump vent line (3) from injection pump (4).
- (3) Refer to page L-105 for high pressure fuel line removal.
- (4) Refer to page L-106 for fuel drain manifold removal.
- (5) Refer to page L-107 for low pressure fuel line removal.

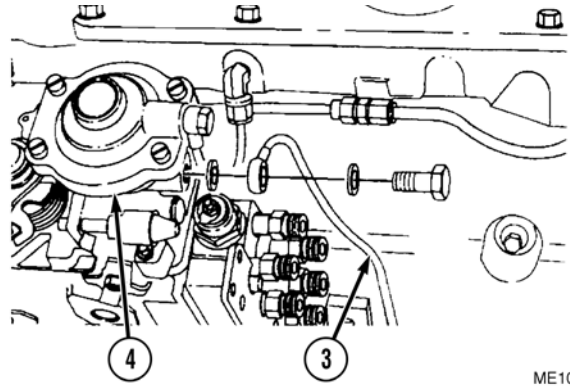

**b. Cleaning.**

**WARNING**

- Degreasing Solvent (MIL-PRF-680) is toxic and flammable. Keep away from heat or flame. Never smoke when using solvent. The flashpoint for Type II Degreasing Solvent is 141 °F (61 °C). Wear protective goggles, face shield, and gloves; use only in a well-ventilated area; avoid contact with skin, eyes, and clothes; and do not breathe vapors. Failure to comply may result in injury or death to personnel.
- If personnel become dizzy while using cleaning solvent, immediately get fresh air and medical help. If solvent contacts skin or clothes, flush with cold water. If solvent contacts eyes, immediately flush eyes with water and get immediate medical attention.
- Adhesives, solvents, and sealing compounds burn easily and give off vapors that are harmful to the skin and clothing. To avoid injury or death, keep away from open fire when using these materials, and use only in well-ventilated areas. If adhesives, solvents, or sealing compounds contact the skin or clothing, wash immediately with soap and water, and rinse thoroughly. Failure to comply may result in injury or death to personnel.

Refer to page L-370 for cleaning.

**c. Inspection.**

Refer to page L-370 for inspection.

**d. Installation.**

- (1) Refer to page L-192 for high pressure fuel line installation.
- (2) Refer to page L-190 for injection pump supply line installation.
- (3) Refer to page L-191 for fuel drain manifold installation.
- (4) Refer to page L-191 for injection pump vent line installation.

**e. Follow-On Maintenance.**

Close engine hood and attach clips (TM 5-2420-230-10).

**END OF TASK**



**L-16. AFTERCOOLER REPLACEMENT.**

This Task Covers:

- |            |                 |                          |
|------------|-----------------|--------------------------|
| a. Removal | b. Cleaning     | c. Inspection            |
| d. Testing | e. Installation | f. Follow-On Maintenance |

**INITIAL SETUP**

*Test Equipment*  
None

*References*  
None

*Tools and Special Tools*  
Tool kit, common no. 2, Item 36, Appendix B  
Tool kit, general mechanics, Para 38

*Equipment Conditions*  
*TM or Para*      *Condition Description*  
TM 5-2420-230-10      Hood raised.

*Materials/Parts*  
Adhesive, sealant, Item 25, Appendix C  
Compound, sealing, pipe, thread, Item 22, Appendix C  
Gasket, Item 74, Appendix D  
Gasket, Item 77, Appendix D (2)  
Soap solution, Item 56, Appendix C  
Solvent, degreasing, Item 58, Appendix C

*Drawings Required*  
TM 5-2420-230-24P      Figure 41

*Estimated Time to Complete*  
Refer to MAC in Appendix B

*Personnel Required*  
MOS 62B, Construction Equipment Repairer

**a. Removal.**



Allow engine to cool before performing maintenance on the muffler, exhaust pipe, exhaust manifold, or turbocharger. If necessary, use insulated pads and gloves.

Refer to page L-108 for removal.

**b. Cleaning.****WARNING**

- Degreasing Solvent (MIL-PRF-680) is toxic and flammable. Keep away from heat or flame. Never smoke when using solvent. The flashpoint for Type II Degreasing Solvent is 141 °F (61 °C). Wear protective goggles, face shield, and gloves; use only in a well-ventilated area; avoid contact with skin, eyes, and clothes; and do not breathe vapors. Failure to comply may result in injury or death to personnel.
- If personnel become dizzy while using cleaning solvent, immediately get fresh air and medical help. If solvent contacts skin or clothes, flush with cold water. If solvent contacts eyes, immediately flush eyes with water and get immediate medical attention.
- Adhesives, solvents, and sealing compounds burn easily and give off vapors that are harmful to the skin and clothing. To avoid injury or death, keep away from open fire when using these materials, and use only in well-ventilated areas. If adhesives, solvents, or sealing compounds contact the skin or clothing, wash immediately with soap and water, and rinse thoroughly. Failure to comply may result in injury or death to personnel.
- To avoid personal injury, wear protective equipment when using compressed air. Failure to comply may result in injury or death to personnel.

- (1) Refer to page L-415 for cleaning.
- (2) Refer to page L-416 for air transfer pipe cleaning.
- (3) Refer to page L-417 for air crossover tube cleaning.
- (4) Refer to page L-417 for charge air cooler (CAC) cleaning.

**c. Inspection.**

- (1) Refer to page L-415 for inspection.
- (2) Refer to page L-416 for air transfer pipe inspection.
- (3) Refer to page L-417 for air crossover tube inspection.
- (4) Refer to page L-417 for charge air cooler (CAC) inspection.

**d. Testing.**

Refer to page L-418 for charge air cooler (CAC) pressure testing.

**e. Installation.****WARNING**

Adhesives, solvents, and sealing compounds burn easily and give off vapors that are harmful to the skin and clothing. To avoid injury or death, keep away from open fire when using these materials, and use only in well-ventilated areas. If adhesives, solvents, or sealing compounds contact the skin or clothing, wash immediately with soap and water, and rinse thoroughly. Failure to comply may result in injury or death to personnel.

Refer to page L-190 for installation.

**f. Follow-On Maintenance.**

Close engine hood and attach clips (TM 5-2420-230-10).

**END OF TASK**







**L-19. ENGINE REPAIR (ROCKER LEVERS REPLACEMENT).**

This Task Covers:

- |                 |                          |               |
|-----------------|--------------------------|---------------|
| a. Removal      | b. Cleaning              | c. Inspection |
| d. Installation | e. Follow-On Maintenance |               |

**INITIAL SETUP**

*Test Equipment*  
None

*References*  
None

*Tools and Special Tools*  
Tool kit, general mechanics, Item 38, Appendix B

*Equipment Conditions*  
*TM or Para*      *Condition Description*  
Para L-17      Valve covers removed.

*Materials/Parts*  
Oil, lubricating, OE/HDO 30, Item 44, Appendix C  
Soap, laundry, Item 56, Appendix C

*Drawings Required*  
TM 5-2420-230-24P      Figure 13

*Personnel Required*  
MOS 62B, Construction Equipment Repairer

*Estimated Time to Complete*  
Refer to MAC in Appendix B

**a. Removal.**

**WARNING**

- No smoking, flames, sparks, or glowing or hot objects allowed within 50 ft. (15 m) of vehicle. Failure to comply may result in injury or death to personnel.
- To prevent possible injury, wear gloves and protective eye equipment when handling fuel. Failure to comply may result in injury or death to personnel.
- Keep a fire extinguisher within easy reach when working with fuel or on a fuel system.
- Do not work on fuel system when engine is hot; fuel can be ignited by a hot engine.

Refer to page L-110 for removal.

**b. Cleaning.**

Refer to page L-291 for cleaning.

**c. Inspection.**

Refer to page L-291 for inspection.

**d. Installation.**

Refer to page L-183 for installation.

**e. Follow-On Maintenance.**

Install valve covers (Para L-17).

**END OF TASK**

**L-20. ENGINE REPAIR (PUSH RODS REPLACEMENT).**

This Task Covers:

- a. Removal
- b. Inspection
- c. Installation
- d. Adjustment
- e. Follow-On Maintenance

**INITIAL SETUP**

*Test Equipment*  
None

*References*  
None

*Tools and Special Tools*  
Tool kit, general mechanics, Item 38, Appendix B

*Equipment Conditions*  
*TM or Para*      *Condition Description*  
Para L-19      Rocker levers removed.

*Materials/Parts*  
Solution, soap, Item 56, Appendix C  
Oil, lubricating, OE/HDO-30, Item 44, Appendix C

*Drawings Required*  
TM 5-2420-230-24P Figure 13

*Personnel Required*  
MOS 62B, Construction Equipment Repairer

*Estimated Time to Complete*  
Refer to MAC in Appendix B

**a. Removal.**

**WARNING**

- No smoking, flames, sparks, or glowing or hot objects allowed within 50 ft. (15 m) of vehicle. Failure to comply may result in injury or death to personnel.
- To prevent possible injury, wear gloves and protective eye equipment when handling fuel. Failure to comply may result in injury or death to personnel.
- Keep a fire extinguisher within easy reach when working with fuel or on a fuel system.
- Do not work on fuel system when engine is hot; fuel can be ignited by a hot engine.

Refer to page L-110 for removal.

**b. Inspection.**

Refer to page L-297 for inspection.

**c. Installation.**

Refer to page L-182 for installation.

**d. Adjustment.**

Refer to page L-186 for valve clearance adjustment.

**e. Follow-On Maintenance.**

Install rocker levers (Para L-19).

**END OF TASK**

**L-21. CYLINDER HEAD MAINTENANCE.**

This Task Covers:

- |               |                 |                          |
|---------------|-----------------|--------------------------|
| a. Removal    | a.1 Disassembly | b. Inspection            |
| c. Cleaning   | c.1 Assembly    | d. Installation          |
| e. Tightening | f. Adjustment   | g. Follow-On Maintenance |

**INITIAL SETUP**

*Test Equipment*  
None

*Personnel Required*  
MOS 62B, Construction Equipment Repairer (2)

*Tools and Special Tools*  
Injector bore brush, Item 3, Appendix B  
Field maintenance, basic, Item 23, Appendix B  
Tool kit, common no. 2, Item 36, Appendix B  
Tool kit, general mechanics, Item 38, Appendix B

*References*  
None

*Equipment Conditions*  
*TM or Para*                      *Condition Description*  
Para L-20                              Push rods removed.

*Materials/Parts*  
Gasket, Item 60, Appendix D  
O-ring, Item 135, Appendix D (12)  
Scotch brite pad, Item 53, Appendix C  
Soap, laundry, Item 56, Appendix C  
Solvent, degreasing, Item 58, Appendix C

*Drawings Required*  
TM 5-2420-230-24P    Figure 11

*Estimated Time to Complete*  
Refer to MAC in Appendix B

**a. Removal.**



- No smoking, flames, sparks, or glowing or hot objects allowed within 50 ft. (15 m) of vehicle. Failure to comply may result in injury or death to personnel.
- To prevent possible injury, wear gloves and protective eye equipment when handling fuel. Failure to comply may result in injury or death to personnel.
- Keep a fire extinguisher within easy reach when working with fuel or on a fuel system.
- Do not work on fuel system when engine is hot; fuel can be ignited by a hot engine.

Refer to page L-111 for removal.

**a.1 Disassembly.**

Refer to page L-269 for disassembly.

**b. Inspection.**

Refer to page L-269 for inspection.

**c. Cleaning.****WARNING**

- Degreasing Solvent (MIL-PRF-680) is toxic and flammable. Keep away from heat or flame. Never smoke when using solvent. The flashpoint for Type II Degreasing Solvent is 141 °F (61 °C). Wear protective goggles, face shield, and gloves; use only in a well-ventilated area; avoid contact with skin, eyes, and clothes; and do not breathe vapors. Failure to comply may result in injury or death to personnel.
- If personnel become dizzy while using cleaning solvent, immediately get fresh air and medical help. If solvent contacts skin or clothes, flush with cold water. If solvent contacts eyes, immediately flush eyes with water and get immediate medical attention.
- Adhesives, solvents, and sealing compounds burn easily and give off vapors that are harmful to the skin and clothing. To avoid injury or death, keep away from open fire when using these materials, and use only in well-ventilated areas. If adhesives, solvents, or sealing compounds contact the skin or clothing, wash immediately with soap and water, and rinse thoroughly. Failure to comply may result in injury or death to personnel.
- To avoid personal injury, wear protective equipment when using compressed air. Failure to comply may result in injury or death to personnel.

Refer to pages L-269 and L-270 for cleaning.

**c.1 Assembly.**

Refer to page L-284 for assembly.

**d. Installation.**

Refer to page L-181 for installation.

**e. Tightening.**

Refer to page L-184 to tighten the cylinder head.

**f. Adjustment.**

Refer to page L-186 for valve clearance adjustment.

**g. Follow-On Maintenance.**

Install push rods (Para L-20).

**END OF TASK**

**L-22. ENGINE REPAIR (FRONT COVER REPLACEMENT).**

This Task Covers:

- a. Removal
- b. Installation
- c. Follow-On Maintenance

**INITIAL SETUP**

*Test Equipment*  
None

*References*  
None

*Tools and Special Tools*  
 Inserter, seal, Item 27, Appendix B  
 Tool kit, common no. 2, Item 36, Appendix B  
 Tool kit, general mechanics, Item 38, Appendix B

*Equipment Conditions*

<i>TM or Para</i>	<i>Condition Description</i>
Para L-7	Fan pulley removed.
Para L-8	Vibration damper/crankshaft pulley removed.
Para 4-4	Engine oil filter removed.

*Materials/Parts*  
 Oil, lubricating, OE/HDO-30, Item 44, Appendix C  
 Three Bond 1207-C, Item 67, Appendix C  
 Gasket, Item 66, Appendix D  
 Gasket, Item 78, Appendix D  
 Packing, performed, Item 164, Appendix D  
 Seal, Item 227, Appendix D

*Drawings Required*  
 TM 5-2420-230-24P Figure 18

*Estimated Time to Complete*  
 Refer to MAC in Appendix B

*Personnel Required*  
 MOS 62B, Construction Equipment Repairer

**a. Removal.**

Refer to page L-111 for removal.

**b. Installation.**



Adhesives, solvents, and sealing compounds burn easily and give off vapors that are harmful to the skin and clothing. To avoid injury or death, keep away from open fire when using these materials, and use only in well-ventilated areas. If adhesives, solvents, or sealing compounds contact the skin or clothing, wash immediately with soap and water, and rinse thoroughly. Failure to comply may result in injury or death to personnel.

Refer to page L-180 for installation.

**c. Follow-On Maintenance.**

- (1) Install fan pulley (Para L-7).
- (2) Install vibration damper/crankshaft pulley (Para L-8).
- (3) Install engine oil filter (Para 4-4).

**END OF TASK**

**L-23. WATER PUMP REPLACEMENT.**

This Task Covers:

- a. Removal
- b. Inspection
- c. Installation
- d. Follow-On Maintenance

**INITIAL SETUP**

*Test Equipment*  
None

*References*  
None

*Tools and Special Tools*  
Tool kit, common no. 2, Item 36, Appendix B  
Tool kit, general mechanics, Item 38, Appendix B

*Equipment Conditions*  
*TM or Para*      *Condition Description*  
Para 4-6      Drive belt removed.

*Materials/Parts*  
Kit, water pump, Item 96, Appendix D

*Drawings Required*  
TM 5-2420-230-24P Figure 28

*Personnel Required*  
MOS 62B, Construction Equipment Repairer

*Estimated Time to Complete*  
Refer to MAC in Appendix B

**a. Removal.**

Refer to page L-112 for removal.

**b. Inspection.**

Refer to page L-393 for inspection.

**c. Installation.**

Refer to page L-179 for installation.

**d. Follow-On Maintenance.**

Install drive belt (Para 4-6).

**END OF TASK**

**L-24. FLYWHEEL REPLACEMENT.**

This Task Covers:

- a. Removal
- b. Inspection
- c. Installation
- d. Follow-On Maintenance

**INITIAL SETUP**

*Test Equipment*  
None

*References*  
None

*Tools and Special Tools*  
Tool kit, common no. 2, Item 36, Appendix B  
Tool kit, general mechanics, Item 38, Appendix B

*Equipment Conditions*

<i>TM or Para</i>	<i>Condition Description</i>
Para 4-10	Engine separated from transmission.
Para 12-11	Starter removed.

*Materials/Parts*  
None

*Drawings Required*  
TM 5-2420-230-24P Figure 4

*Personnel Required*  
MOS 62B, Construction Equipment Repairer

*Estimated Time to Complete*  
Refer to MAC in Appendix B

**a. Removal.**

Refer to page L-112 for removal.

**b. Inspection.**

Refer to page L-471 for inspection.

**c. Installation.**

Refer to page L-178 for installation.

**d. Follow-On Maintenance.**

- (1) Install starter (Para 12-11).
- (2) Connect engine to transmission (Para 4-10).

**END OF TASK**

**L-25. FLYWHEEL HOUSING REPLACEMENT.**

This Task Covers:

- a. Removal
- b. Inspection
- c. Installation
- d. Follow-On Maintenance

**INITIAL SETUP**

*Test Equipment*  
None

*References*  
None

*Tools and Special Tools*  
Tool kit, common no. 2, Item 36, Appendix B  
Tool kit, general mechanics, Item 38, Appendix B

*Equipment Conditions*  
*TM or Para*      *Condition Description*  
Para L-24      Flywheel removed.

*Materials/Parts*  
Coating, copper, Item 11, Appendix C  
Grease, lithium, Item 34, Appendix C

*Drawings Required*  
TM 5-2420-230-24P Figure 4

*Personnel Required*  
MOS 62B, Construction Equipment Repairer

*Estimated Time to Complete*  
Refer to MAC in Appendix B

**a. Removal.**

Refer to page L-112 for removal.

**b. Inspection.**

Refer to page L-472 for inspection.

**c. Installation.**

**WARNING**

Adhesives, solvents, and sealing compounds burn easily and give off vapors that are harmful to the skin and clothing. To avoid injury or death, keep away from open fire when using these materials, and use only in well-ventilated areas. If adhesives, solvents, or sealing compounds contact the skin or clothing, wash immediately with soap and water, and rinse thoroughly. Failure to comply may result in injury or death to personnel.

Refer to page L-178 for installation.

**d. Follow-On Maintenance.**

Install flywheel (Para L-24).

**END OF TASK**



**L-26. INJECTION PUMP REPLACEMENT.**

This Task Covers:

- a. Removal
- b. Adjustment
- c. Installation
- d. Follow-On Maintenance

**INITIAL SETUP**

*Test Equipment*  
None

*Personnel Required*  
MOS 62B, Construction Equipment Repairer

*Tools and Special Tools*  
Engine barring tool, Item 2, Appendix B  
Field maintenance, basic, Item 23, Appendix B  
Tool kit, common no. 2, Item 36, Appendix B  
Tool kit, general mechanics, Item 38, Appendix B

*References*  
None

*Equipment Conditions*  
*TM or Para*      *Condition Description*  
TM 5-2420-230-10      Hood raised.

*Materials/Parts*  
STP, Item 29, Appendix C  
Washer, lock, Item 279, Appendix D (2)

*Drawings Required*  
TM 5-2420-230-24P      Figure 36

*Estimated Time to Complete*  
Refer to MAC in Appendix B

**a. Removal.**

**WARNING**

- No smoking, flames, sparks, or glowing or hot objects allowed within 50 ft. (15 m) of vehicle. Failure to comply may result in injury or death to personnel.
- To prevent possible injury, wear gloves and protective eye equipment when handling fuel. Failure to comply may result in injury or death to personnel.
- Keep a fire extinguisher within easy reach when working with fuel or on a fuel system.
- Do not work on fuel system when engine is hot; fuel can be ignited by a hot engine.

Refer to page L-115 for removal.

**b. Adjustment.**

Refer to page L-319 for timing.

**c. Installation.**

Refer to page L-169 for installation.

**d. Follow-On Maintenance.**

Close engine hood and attach clips (TM 5-2420-230-10).

**END OF TASK**

**L-27. FUEL TRANSFER PUMP REPLACEMENT.**

This Task Covers:

- |                 |                          |             |
|-----------------|--------------------------|-------------|
| a. Removal      | b. Inspection            | c. Cleaning |
| d. Installation | e. Follow-On Maintenance |             |

**INITIAL SETUP**

*Test Equipment*

None

*References*

None

*Tools and Special Tools*

- Pan, drain, Item 29, Appendix B
- Tool kit, common no. 2, Item 36, Appendix B
- Tool kit, general mechanics, Item 38, Appendix B

*Equipment Conditions*

<i>TM or Para</i>	<i>Condition Description</i>
TM 5-2420-230-10	Hood raised.

*Materials/Parts*

- Oil, lubricating, OE/HDO-10, Item 44, Appendix C
- Gasket, fuel transfer pump, Item 82, Appendix D

*Drawings Required*

TM 5-2420-230-24P Figure 35

*Personnel Required*

MOS 62B, Construction Equipment Repairer

*Estimated Time to Complete*

Refer to MAC in Appendix B

**a. Removal.**

**WARNING**

- No smoking, flames, sparks, or glowing or hot objects allowed within 50 ft. (15 m) of vehicle. Failure to comply may result in injury or death to personnel.
- To prevent possible injury, wear gloves and protective eye equipment when handling fuel. Failure to comply may result in injury or death to personnel.
- Keep a fire extinguisher within easy reach when working with fuel or on a fuel system.
- Do not work on fuel system when engine is hot; fuel can be ignited by a hot engine.

Refer to page L-117 for removal.

**b. Inspection.**

Refer to page L-367 for inspection.

**c. Cleaning.**

Refer to page L-367 for cleaning.

**d. Installation.**

Refer to page L-158 for installation.

**e. Follow-On Maintenance.**

Close engine hood and attach clips (TM 5-2420-230-10).

**END OF TASK**

**L-28. ENGINE REPAIR (TAPPET COVER REPLACEMENT).**

This Task Covers:

a. Removal

b. Installation

c. Follow-On Maintenance

**INITIAL SETUP**

*Test Equipment*

None

*References*

None

*Tools and Special Tools*

Tool kit, common no. 2, Item 36, Appendix B  
 Tool kit, general mechanics, Item 38, Appendix B

*Equipment Conditions*

<i>TM or Para</i>	<i>Condition Description</i>
Para L-26	Injection pump removed.

*Materials/Parts*

Gasket, tappet cover, Item 61, Appendix D  
 Packing, preformed, Item 167, Appendix D (4)

*Drawings Required*

TM 5-2420-230-24P Figure 22

*Personnel Required*

MOS 62B, Construction Equipment Repairer

*Estimated Time to Complete*

Refer to MAC in Appendix B

**a. Removal.**

Refer to page L-117 for removal.

**b. Installation.**

Refer to page L-159 for installation.

**c. Follow-On Maintenance.**

Install injection pump (Para L-26).

**END OF TASK**

**L-29. ENGINE OIL COOLER REPLACEMENT.**

This Task Covers:

- |                 |                          |               |
|-----------------|--------------------------|---------------|
| a. Removal      | b. Cleaning              | c. Inspection |
| d. Installation | e. Follow-On Maintenance |               |

**INITIAL SETUP**

<i>Test Equipment</i> None	<i>References</i> None	
<i>Tools and Special Tools</i> Tool kit, common no. 2, Item 36, Appendix B Tool kit, general mechanics, Item 38, Appendix B	<i>Equipment Conditions</i> <i>TM or Para</i> Para 12-10 Para 9-4	<i>Condition Description</i> Alternator removed. Coolant drained.
<i>Materials/Parts</i> Solvent, degreasing, Item 58, Appendix C Gasket, oil cooler, Item 71, Appendix D Gasket, oil cooler cover, Item 72, Appendix D	<i>Drawings Required</i> TM 5-2420-230-24P	Figure 29
<i>Personnel Required</i> MOS 62B, Construction Equipment Repairer	<i>Estimated Time to Complete</i> Refer to MAC in Appendix B	

**a. Removal.**

Refer to page L-118 for removal.

**b. Cleaning.**

**WARNING**

- Degreasing Solvent (MIL-PRF-680) is toxic and flammable. Keep away from heat or flame. Never smoke when using solvent. The flashpoint for Type II Degreasing Solvent is 141 °F (61 °C). Wear protective goggles, face shield, and gloves; use only in a well-ventilated area; avoid contact with skin, eyes, and clothes; and do not breathe vapors. Failure to comply may result in injury or death to personnel.
- If personnel become dizzy while using cleaning solvent, immediately get fresh air and medical help. If solvent contacts skin or clothes, flush with cold water. If solvent contacts eyes, immediately flush eyes with water and get immediate medical attention.
- Adhesives, solvents, and sealing compounds burn easily and give off vapors that are harmful to the skin and clothing. To avoid injury or death, keep away from open fire when using these materials, and use only in well-ventilated areas. If adhesives, solvents, or sealing compounds contact the skin or clothing, wash immediately with soap and water, and rinse thoroughly. Failure to comply may result in injury or death to personnel.

Refer to page L-382 for cleaning.

**c. Inspection.**

Refer to page L-382 for inspection.

**d. Installation.**

Refer to page L-158 for installation.

**e. Follow-On Maintenance.**

- (1) Install alternator (Para 12-10).
- (2) Refill coolant (Para 9-4).

**END OF TASK**

**L-30. ENGINE REPAIR (WATER INLET CONNECTION REPLACEMENT).**

This Task Covers:

a. Removal

b. Installation

c. Follow-On Maintenance

**INITIAL SETUP**

*Test Equipment*

None

*References*

None

*Tools and Special Tools*

Tool kit, general mechanics, Item 38, Appendix B

*Equipment Conditions*

*TM or Para*

*Condition Description*

TM 5-2420-230-10

Hood raised.

*Materials/Parts*

Gasket, Item 64, Appendix D

*Drawings Required*

TM 5-2420-230-24P

Figure 28

*Personnel Required*

MOS 62B, Construction Equipment Repairer

*Estimated Time to Complete*

Refer to MAC in Appendix B

**a. Removal.**

Refer to page L-118 for removal.

**b. Installation.**

Refer to page L-200 for installation.

**c. Follow-On Maintenance.**

Close engine hood and attach clips (TM 5-2420-230-10).

**END OF TASK**

**L-31. OIL PAN REPLACEMENT.**

This Task Covers:

- a. Removal
- b. Installation
- c. Follow-On Maintenance

**INITIAL SETUP**

*Test Equipment*

None

*References*

None

*Tools and Special Tools*

- Tool kit, common no. 2, Item 36, Appendix B
- Tool kit, general mechanics, Item 38, Appendix B

*Equipment Conditions*

<i>TM or Para</i>	<i>Condition Description</i>
Para 4-4	Oil drained.
Para 14-6	Front drive axle disconnected.

*Materials/Parts*

- Three Bond 1207-C, Item 67, Appendix C
- Gasket, Item 75, Appendix D

*Drawings Required*

TM 5-2420-230-24P Figure 21

*Personnel Required*

MOS 62B, Construction Equipment Repairer

*Estimated Time to Complete*

Refer to MAC in Appendix B

**a. Removal.**

**WARNING**

Fuel and oil are slippery and can cause falls. To avoid injury, wipe up spilled fuel or oil with rags.

- (1) Deleted.
- (2) Refer to page L-119 for oil pan removal.

**b. Installation.**

**WARNING**

Adhesives, solvents, and sealing compounds burn easily and give off vapors that are harmful to the skin and clothing. To avoid injury or death, keep away from open fire when using these materials, and use only in well-ventilated areas. If adhesives, solvents, or sealing compounds contact the skin or clothing, wash immediately with soap and water, and rinse thoroughly. Failure to comply may result in injury or death to personnel.

- (1) Refer to page L-157 for installation.
- (2) Deleted.

**c. Follow-On Maintenance.**

- (1) Refill oil (Para 4-4).
- (2) Connect front drive axle (Para 14-6).

**END OF TASK**







**L-34. CAMSHAFT REPLACEMENT.**

This Task Covers:

- |                 |               |                          |
|-----------------|---------------|--------------------------|
| a. Removal      | b. Servicing  | c. Inspection            |
| d. Installation | e. Adjustment | f. Follow-On Maintenance |

**INITIAL SETUP**

*Test Equipment*  
None

*References*  
None

*Tools and Special Tools*  
Field maintenance, basic, Item 23, Appendix B  
Tool kit, common no. 2, Item 36, Appendix B  
Tool kit, general mechanics, Item 38, Appendix B

*Equipment Conditions*

<i>TM or Para</i>	<i>Condition Description</i>
Para L-33	Rear seal housing removed.
Para L-22	Front cover removed.
Para L-26	Injection pump removed.

*Materials/Parts*  
Cloth, lint free, Item 10, Appendix C  
Solvent, degreasing, Item 58, Appendix C  
Grease, lithium, Item 34, Appendix C  
Bearing, sleeve, Item 26, Appendix D

*Drawings Required*  
TM 5-2420-230-24P Figure 5  
TM 5-2420-230-24P Figure 6

*Personnel Required*  
MOS 62B, Construction Equipment Repairer

*Estimated Time to Complete*  
Refer to MAC in Appendix B

**a. Removal.**

**WARNING**

Fuel and oil are slippery and can cause falls. To avoid injury, wipe up spilled fuel or oil with rags.

Refer to page L-120 for removal.

**b. Servicing.**

**WARNING**

- Degreasing Solvent (MIL-PRF-680) is toxic and flammable. Keep away from heat or flame. Never smoke when using solvent. The flashpoint for Type II Degreasing Solvent is 141 °F (61 °C). Wear protective goggles, face shield, and gloves; use only in a well-ventilated area; avoid contact with skin, eyes, and clothes; and do not breathe vapors. Failure to comply may result in injury or death to personnel.
- If personnel become dizzy while using cleaning solvent, immediately get fresh air and medical help. If solvent contacts skin or clothes, flush with cold water. If solvent contacts eyes, immediately flush eyes with water and get immediate medical attention.
- Adhesives, solvents, and sealing compounds burn easily and give off vapors that are harmful to the skin and clothing. To avoid injury or death, keep away from open fire when using these materials, and use only in well-ventilated areas. If adhesives, solvents, or sealing compounds contact the skin or clothing, wash immediately with soap and water, and rinse thoroughly. Failure to comply may result in injury or death to personnel.

Refer to page L-232 for cleaning.

**c. Inspection.**

Refer to page L-232 for inspection.

**d. Installation.**

**WARNING**

Adhesives, solvents, and sealing compounds burn easily and give off vapors that are harmful to the skin and clothing. To avoid injury or death, keep away from open fire when using these materials, and use only in well-ventilated areas. If adhesives, solvents, or sealing compounds contact the skin or clothing, wash immediately with soap and water, and rinse thoroughly. Failure to comply may result in injury or death to personnel.

Refer to page L-145 for installation.

**e. Adjustment.**

Refer to page L-147 for end play measurement.

**f. Follow-On Maintenance.**

- (1) Install rear seal housing (Para L-33).
- (2) Install front cover (Para L-22).
- (3) Install injection pump (Para L-26).

**END OF TASK**

**L-35. ENGINE REPAIR (VALVE TAPPETS REPLACEMENT).**

This Task Covers:

- a. Removal
- b. Inspection
- c. Installation
- d. Follow-On Maintenance

**INITIAL SETUP**

*Test Equipment*  
None

*References*  
None

*Tools and Special Tools*  
Tool kit, general mechanics, Item 38, Appendix B

*Equipment Conditions*

<i>TM or Para</i>	<i>Condition Description</i>
Para L-28	Tappet cover removed.
Para L-34	Camshaft removed.

*Materials/Parts*  
Grease, lithium, Item 34, Appendix C

*Drawings Required*  
TM 5-2420-230-24P Figure 6

*Personnel Required*  
MOS 62B, Construction Equipment Repairer

*Estimated Time to Complete*  
Refer to MAC in Appendix B

**a. Removal.**



Fuel and oil are slippery and can cause falls. To avoid injury, wipe up spilled fuel or oil with rags.

Refer to page L-121 for removal.

**b. Inspection.**

Refer to page L-297 for inspection.

**c. Installation.**



Adhesives, solvents, and sealing compounds burn easily and give off vapors that are harmful to the skin and clothing. To avoid injury or death, keep away from open fire when using these materials, and use only in well-ventilated areas. If adhesives, solvents, or sealing compounds contact the skin or clothing, wash immediately with soap and water, and rinse thoroughly. Failure to comply may result in injury or death to personnel.

Refer to page L-131 for installation.

**d. Follow-On Maintenance.**

- (1) Install tappet cover (Para L-28).
- (2) Install camshaft (Para L-34).

**END OF TASK**

**L-36. OIL PUMP REPLACEMENT.**

This Task Covers:

- a. Removal
- b. Inspection
- c. Cleaning
- d. Installation
- e. Follow-On Maintenance

**INITIAL SETUP**

*Test Equipment*  
None

*References*  
None

*Tools and Special Tools*  
Field maintenance, basic, Item 23, Appendix B  
Tool kit, common no. 2, Item 36, Appendix B  
Tool kit, general mechanics, Item 38, Appendix B

*Equipment Conditions*  
*TM or Para*                      *Condition Description*  
Para L-34                              Camshaft removed.

*Materials/Parts*  
Oil, lubricating, OE/HDO-30, Item 44, Appendix C  
Solvent, degreasing, Item 58, Appendix C

*Drawings Required*  
TM 5-2420-230-24P    Figure 14

*Personnel Required*  
MOS 62B, Construction Equipment Repairer

*Estimated Time to Complete*  
Refer to MAC in Appendix B

**a. Removal.**

**WARNING**

Fuel and oil are slippery and can cause falls. To avoid injury, wipe up spilled fuel or oil with rags.

Refer to page L-121 for removal.

**b. Inspection.**

Refer to page L-386 for inspection.

**c. Cleaning.**

**WARNING**

- Degreasing Solvent (MIL-PRF-680) is toxic and flammable. Keep away from heat or flame. Never smoke when using solvent. The flashpoint for Type II Degreasing Solvent is 141 °F (61 °C). Wear protective goggles, face shield, and gloves; use only in a well-ventilated area; avoid contact with skin, eyes, and clothes; and do not breathe vapors. Failure to comply may result in injury or death to personnel.
- If personnel become dizzy while using cleaning solvent, immediately get fresh air and medical help. If solvent contacts skin or clothes, flush with cold water. If solvent contacts eyes, immediately flush eyes with water and get immediate medical attention.
- Adhesives, solvents, and sealing compounds burn easily and give off vapors that are harmful to the skin and clothing. To avoid injury or death, keep away from open fire when using these materials, and use only in well-ventilated areas. If adhesives, solvents, or sealing compounds contact the skin or clothing, wash immediately with soap and water, and rinse thoroughly. Failure to comply may result in injury or death to personnel.

Refer to page L-387 for cleaning.

**d. Installation.**

Refer to page L-144 for installation.

**e. Follow-On Maintenance.**

Install camshaft (Para L-34).

**END OF TASK**

<b>L-37. ENGINE REPAIR (GEAR HOUSING REPLACEMENT).</b>		
This Task Covers:		
a. Removal	b. Inspection	c. Installation
d. Follow-On Maintenance		
<b>INITIAL SETUP</b>		
<i>Test Equipment</i> None	<i>Personnel Required</i> MOS 62B, Construction Equipment Repairer	
<i>Tools and Special Tools</i> Tool kit, common no. 2, Item 36, Appendix B Tool kit, general mechanics, Item 38, Appendix B	<i>References</i> None	
<i>Materials/Parts</i> Compound, Sealing, Item 19, Appendix C Loctite 601, Item 24, Appendix C Gasket, Item 66, Appendix D Gasket, Item 78, Appendix D Packing, preformed, Item 164, Appendix D	<i>Equipment Conditions</i>	
	<i>TM or Para</i> Para L-34	<i>Condition Description</i> Camshaft removed.
	<i>Drawings Required</i> TM 5-2420-230-24P Figure 18	
	<i>Estimated Time to Complete</i> Refer to MAC in Appendix B	

**a. Removal.**



Fuel and oil are slippery and can cause falls. To avoid injury, wipe up spilled fuel or oil with rags.

- (1) Refer to page L-123 for gear housing removal.
- (2) Refer to page L-123 for timing pin housing removal.
- (3) Refer to page L-261 for fuel pump stud removal.
- (4) Refer to page L-262 for data plate removal.

**b. Inspection.**

Refer to page L-260 for inspection.

**c. Installation.**

**WARNING**

Adhesives, solvents, and sealing compounds burn easily and give off vapors that are harmful to the skin and clothing. To avoid injury or death, keep away from open fire when using these materials, and use only in well-ventilated areas. If adhesives, solvents, or sealing compounds contact the skin or clothing, wash immediately with soap and water, and rinse thoroughly. Failure to comply may result in injury or death to personnel.

- (1) Refer to page L-148 for timing pin housing installation.
- (2) Refer to page L-261 for fuel pump stud installation.
- (3) Refer to page L-262 for data plate installation.
- (4) Refer to page L-143 for gear housing installation.

**d. Follow-On Maintenance.**

Install camshaft (Para L-34).

**END OF TASK**



**L-39. CRANKSHAFT REPLACEMENT.**

This Task Covers:

- |                 |               |                          |
|-----------------|---------------|--------------------------|
| a. Removal      | b. Cleaning   | c. Inspection            |
| d. Installation | e. Adjustment | f. Follow-On Maintenance |

**INITIAL SETUP**

*Test Equipment*

None

*Personnel Required*

MOS 62B, Construction Equipment Repairer (2)

*Tools and Special Tools*

- Field maintenance, basic, Item 23, Appendix B
- Tool kit, common no. 2, Item 36, Appendix B
- Tool kit, general mechanics, Item 38, Appendix B
- Wear sleeve installation tool, Item 41, Appendix B

*References*

None

*Equipment Conditions*

<i>TM or Para</i>	<i>Condition Description</i>
Para L-38	Piston and rod assemblies removed.

*Materials/Parts*

- Cloth, crocus, Item 9, Appendix C
- Grease, lithium, Item 34, Appendix C
- Oil, lubricating, OE/HDO-30, Item 44, Appendix C
- Solvent, degreasing, Item 58, Appendix C
- Bearing set, sleeve, Item 24, Appendix D

*Drawings Required*

TM 5-2420-230-24P Figure 3

*Estimated Time to Complete*

Refer to MAC in Appendix B

**a. Removal.**

Refer to page L-128 for removal.

**b. Cleaning.**

**WARNING**

- Degreasing Solvent (MIL-PRF-680) is toxic and flammable. Keep away from heat or flame. Never smoke when using solvent. The flashpoint for Type II Degreasing Solvent is 141 °F (61 °C). Wear protective goggles, face shield, and gloves; use only in a well-ventilated area; avoid contact with skin, eyes, and clothes; and do not breathe vapors. Failure to comply may result in injury or death to personnel.
- If personnel become dizzy while using cleaning solvent, immediately get fresh air and medical help. If solvent contacts skin or clothes, flush with cold water. If solvent contacts eyes, immediately flush eyes with water and get immediate medical attention.
- Adhesives, solvents, and sealing compounds burn easily and give off vapors that are harmful to the skin and clothing. To avoid injury or death, keep away from open fire when using these materials, and use only in well-ventilated areas. If adhesives, solvents, or sealing compounds contact the skin or clothing, wash immediately with soap and water, and rinse thoroughly. Failure to comply may result in injury or death to personnel.

Refer to page L-229 for cleaning.

**c. Inspection.**

Refer to page L-229 for inspection.



**d. Installation.**

**WARNING**

Adhesives, solvents, and sealing compounds burn easily and give off vapors that are harmful to the skin and clothing. To avoid injury or death, keep away from open fire when using these materials, and use only in well-ventilated areas. If adhesives, solvents, or sealing compounds contact the skin or clothing, wash immediately with soap and water, and rinse thoroughly. Failure to comply may result in injury or death to personnel.

Refer to page L-131 for installation.

**e. Adjustment.**

Refer to page L-155 for end play measurement.

**f. Follow-On Maintenance.**

Install piston and rod assemblies (Para L-38).

**END OF TASK**

<b>L-40. CYLINDER BLOCK REPAIR.</b>						
This Task Covers:						
a. Disassembly	b. Cleaning	c. Inspection				
d. De-glazing	e. Assembly	f. Follow-On Maintenance				
<b>INITIAL SETUP</b>						
<i>Test Equipment</i> None	<i>Materials/Parts (Cont.)</i> Sealant, pipe plug, Item 55, Appendix C Soap, laundry, Item 56, Appendix C Solvent, degreasing, Item 58, Appendix C Three Bond 1207-C, Item 67, Appendix C					
<i>Tools and Special Tools</i> Cup plug driver, Item 21, Appendix B Cup plug driver, Item 22, Appendix B Field maintenance, basic, Item 23, Appendix B Tool kit, common no. 2, Item 36, Appendix B Tool kit, general mechanics, Item 38, Appendix B	<i>Personnel Required</i> MOS 62B, Construction Equipment Repairer					
<i>Materials/Parts</i> Bushing, sleeve, Item 35, Appendix D Cloth, lint free, Item 10, Appendix C Kit, hardware, cylinder block, Item 95, Appendix D Loctite 609, Item 24, Appendix C Oil, lubricating, OE/HDO 30, Item 44, Appendix C Paper, abrasive, Item 49, Appendix C Plug, expansion, Item 178, Appendix D (3) Plug, expansion, Item 179, Appendix D (5) Plug, expansion, Item 180, Appendix D (4) Scotch brite pad, Item 53, Appendix C	<i>References</i> None					
	<i>Equipment Conditions</i> <table style="width: 100%; border: none;"> <tr> <td style="width: 50%;"><i>TM or Para</i></td> <td style="width: 50%;"><i>Condition Description</i></td> </tr> <tr> <td>Para L-39</td> <td>Crankshaft removed.</td> </tr> </table>		<i>TM or Para</i>	<i>Condition Description</i>	Para L-39	Crankshaft removed.
<i>TM or Para</i>	<i>Condition Description</i>					
Para L-39	Crankshaft removed.					
	<i>Drawings Required</i> TM 5-2420-230-24P Figure 2					
	<i>Estimated Time to Complete</i> Refer to MAC in Appendix B					

**a. Disassembly.**

Refer to page L-213 for disassembly.

**b. Cleaning.****WARNING**

- Degreasing Solvent (MIL-PRF-680) is toxic and flammable. Keep away from heat or flame. Never smoke when using solvent. The flashpoint for Type II Degreasing Solvent is 141 °F (61 °C). Wear protective goggles, face shield, and gloves; use only in a well-ventilated area; avoid contact with skin, eyes, and clothes; and do not breathe vapors. Failure to comply may result in injury or death to personnel.
- If personnel become dizzy while using cleaning solvent, immediately get fresh air and medical help. If solvent contacts skin or clothes, flush with cold water. If solvent contacts eyes, immediately flush eyes with water and get immediate medical attention.
- Adhesives, solvents, and sealing compounds burn easily and give off vapors that are harmful to the skin and clothing. To avoid injury or death, keep away from open fire when using these materials, and use only in well-ventilated areas. If adhesives, solvents, or sealing compounds contact the skin or clothing, wash immediately with soap and water, and rinse thoroughly. Failure to comply may result in injury or death to personnel.

Refer to page L-215 for cleaning.

**c. Inspection.**

Refer to page L-218 for inspection.

**d. De-glazing.**

Refer to page L-220 for adjustment.

**e. Assembly.****WARNING**

Adhesives, solvents, and sealing compounds burn easily and give off vapors that are harmful to the skin and clothing. To avoid injury or death, keep away from open fire when using these materials, and use only in well-ventilated areas. If adhesives, solvents, or sealing compounds contact the skin or clothing, wash immediately with soap and water, and rinse thoroughly. Failure to comply may result in injury or death to personnel.

- (1) Refer to page L-223 to install expansion and pipe plug.
- (2) Refer to page L-225 to install camshaft expansion plug.
- (3) Refer to page L-226 to install camshaft bushing.

**f. Follow-On Maintenance.**

Install crankshaft (Para L-39).

**END OF TASK**

**L-41. ENGINE REPAIR (CRANKSHAFT GEAR REPLACEMENT).**

This Task Covers:

- a. Removal
- b. Inspection
- c. Installation
- d. Follow-On Maintenance

**INITIAL SETUP**

*Test Equipment*  
None

*References*  
None

*Tools and Special Tools*  
Tool kit, common no. 2, Item 36, Appendix B  
Tool kit, general mechanics, Item 38, Appendix B

*Equipment Conditions*  
*TM or Para*      *Condition Description*  
Para L-39      Crankshaft removed.

*Materials/Parts*  
Grease, lithium, Item 34, Appendix C

*Drawings Required*  
TM 5-2420-230-24P    Figure 3

*Personnel Required*  
MOS 62B, Construction Equipment Repairer

*Estimated Time to Complete*  
Refer to MAC in Appendix B

**a. Removal.**

Refer to page L-230 for removal.

**b. Inspection.**

Refer to page L-230 for inspection.

**c. Installation.**



Adhesives, solvents, and sealing compounds burn easily and give off vapors that are harmful to the skin and clothing. To avoid injury or death, keep away from open fire when using these materials, and use only in well-ventilated areas. If adhesives, solvents, or sealing compounds contact the skin or clothing, wash immediately with soap and water, and rinse thoroughly. Failure to comply may result in injury or death to personnel.

Refer to page L-231 for installation.

**d. Follow-On Maintenance.**

Install crankshaft (Para L-39).

**END OF TASK**

**L-42. ENGINE REPAIR (CAMSHAFT GEAR REPLACEMENT).**

This Task Covers:

- a. Removal
- b. Installation
- c. Follow-On Maintenance

**INITIAL SETUP**

<p><i>Test Equipment</i> None</p> <p><i>Tools and Special Tools</i> Tool kit, general mechanics, Item 38, Appendix B</p> <p><i>Materials/Parts</i> Grease, lithium, Item 34, Appendix C</p> <p><i>Personnel Required</i> MOS 62B, Construction Equipment Repairer</p>	<p><i>References</i> None</p> <p><i>Equipment Conditions</i> <i>TM or Para</i> Para L-34      <i>Condition Description</i> Camshaft removed.</p> <p><i>Drawings Required</i> TM 5-2420-230-24P    Figure 6</p> <p><i>Estimated Time to Complete</i> Refer to MAC in Appendix B</p>
---	--

**a. Removal.**

Refer to page L-237 for removal.

**b. Installation.**



Adhesives, solvents, and sealing compounds burn easily and give off vapors that are harmful to the skin and clothing. To avoid injury or death, keep away from open fire when using these materials, and use only in well-ventilated areas. If adhesives, solvents, or sealing compounds contact the skin or clothing, wash immediately with soap and water, and rinse thoroughly. Failure to comply may result in injury or death to personnel.

Refer to page L-237 for installation.

**c. Follow-On Maintenance.**

Install camshaft (Para L-34).

**END OF TASK**

**L-43. CYLINDER HEAD REPAIR.**

This Task Covers:

- |                |             |                          |
|----------------|-------------|--------------------------|
| a. Disassembly | b. Cleaning | c. Inspection            |
| d. Repair      | e. Assembly | f. Follow-On Maintenance |

**INITIAL SETUP**

*Test Equipment*

None

*Tools and Special Tools*

- Brush, injector cleaning, Item 3, Appendix B
- Cup plug driver, Item 21, Appendix B
- Gauge depth dial indicating, Item 24, Appendix B
- Tool kit, common no. 2, Item 36, Appendix B
- Tool kit, general mechanics, Item 38, Appendix B

*Materials/Parts*

- Compound, valve lapping, Item 17, Appendix C
- Dykem steel blue, Item 28, Appendix C
- JP-8, Item 69, Appendix C
- Loctite 277, Item 26, Appendix C
- O-Ring, Item 135, Appendix D (12)
- Oil, lubricating, GO-90, Item 42, Appendix C
- Paper, abrasive, Item 49, Appendix C

*Materials/Parts (Cont.)*

- Scotch brite pad, Item 53, Appendix C
- Solution, soap, Item 56, Appendix C
- Valve collets, Item 268, Appendix D (12)

*Personnel Required*

MOS 62B, Construction Equipment Repairer

*References*

None

*Equipment Conditions*

<i>TM or Para</i>	<i>Condition Description</i>
Para L-21	Cylinder head removed.

*Drawings Required*

TM 5-2420-230-24P Figure 11

*Estimated Time to Complete*

Refer to MAC in Appendix B

**a. Disassembly.**

Refer to page L-269 for disassembly.

**b. Cleaning.**

**WARNING**

- No smoking, flames, sparks, or glowing or hot objects allowed within 50 ft. (15 m) of vehicle. Failure to comply may result in injury or death to personnel.
- To prevent possible injury, wear gloves and protective eye equipment when handling fuel. Failure to comply may result in injury or death to personnel.
- Keep a fire extinguisher within easy reach when working with fuel or on a fuel system.

Refer to page L-270 for cylinder head cleaning.

**c. Inspection.**

- (1) Refer to page L-272 for valve inspection.
- (2) Refer to page L-274 for cylinder head combustion face inspection.
- (3) Refer to page L-274 for valve seat inspection.
- (4) Refer to page L-275 for valve spring inspection.

**d. Repair.**

**WARNING**

- Adhesives, solvents, and sealing compounds burn easily and give off vapors that are harmful to the skin and clothing. To avoid injury or death, keep away from open fire when using these materials, and use only in well-ventilated areas. If adhesives, solvents, or sealing compounds contact the skin or clothing, wash immediately with soap and water, and rinse thoroughly. Failure to comply may result in injury or death to personnel.
  - Exercise extreme caution when working with acid, wear rubber apron to prevent clothing being damaged. Always wear safety goggles and rubber gloves and do not smoke when performing maintenance with acid tank. Acid can eat the skin. If acid contacts clothes, remove and flush with water. If acid contacts skin, immediately flush skin and get immediate medical attention. Failure to comply may result in injury or death to personnel.
- (1) Refer to page L-276 for cup plug replacement.
  - (2) Refer to page L-278 for valves grinding.
  - (3) Refer to page L-279 for valve seat grinding.

**e. Assembly.**

Refer to page L-284 for assembly.

**f. Follow-On Maintenance.**

Install cylinder head (Para L-21).

**END OF TASK**

**L-44. ENGINE REPAIR (ROCKER LEVER REPAIR).**

This Task Covers:

- |                |                          |               |
|----------------|--------------------------|---------------|
| a. Disassembly | b. Cleaning              | c. Inspection |
| d. Assembly    | e. Follow-On Maintenance |               |

**INITIAL SETUP**

*Test Equipment*  
None

*References*  
None

*Tools and Special Tools*  
Tool kit, common no. 2, Item 36, Appendix B  
Tool kit, general mechanics, Item 38, Appendix B

*Equipment Conditions*  
*TM or Para*      *Condition Description*  
Para L-19      Rocker lever removed.

*Materials/Parts*  
Detergent, laundry, Item 56, Appendix C  
Oil, lubricating, OE/HDO-30, Item 44, Appendix C

*Drawings Required*  
TM 5-2420-230-24P    Figure 13

*Personnel Required*  
MOS 62B, Construction Equipment Repairer

*Estimated Time to Complete*  
Refer to MAC in Appendix B

**a. Disassembly.**

Refer to page L-290 for disassembly.

**b. Cleaning.**

Refer to page L-291 for rocker levers and pedestals cleaning.

**c. Inspection.**

- (1) Refer to page L-291 for rocker lever inspection.
- (2) Refer to page L-292 for rocker lever pedestals inspection.

**d. Assembly.**

Refer to page L-292 for assembly.

**e. Follow-On Maintenance.**

Install rocker levers (Para L-19).

**END OF TASK**

**L-45. ENGINE OIL COOLER REPAIR.**

This Task Covers:

- a. Disassembly
- b. Cleaning
- c. Inspection
- d. Assembly
- e. Follow-On Maintenance

**INITIAL SETUP**

*Test Equipment*  
None

*References*  
None

*Tools and Special Tools*  
Tool kit, common no. 2, Item 36, Appendix B  
Tool kit, general mechanics, Item 38, Appendix B

*Equipment Conditions*  
*TM or Para*      *Condition Description*  
Para L-29      Oil cooler removed.

*Materials/Parts*  
O-ring, Item 136, Appendix D

*Drawings Required*  
TM 5-2420-230-24P Figure 29

*Personnel Required*  
MOS 62B, Construction Equipment Repairer

*Estimated Time to Complete Task*  
Refer to MAC in Appendix B

**a. Disassembly.**

- (1) Refer to page L-380 for pressure regulator valve removal.
- (2) Refer to page L-381 for filter bypass valve removal.

**b. Cleaning.**

Refer to page L-382 for oil cooler cleaning.

**c. Inspection.**

- (1) Refer to page L-382 for oil cooler inspection.
- (2) Refer to page L-380 for pressure regulator valve inspection.

**d. Assembly.**

- (1) Refer to page L-381 for pressure regulator valve installation.
- (2) Refer to page L-381 for filter bypass valve installation.

**e. Follow-On Maintenance.**

Install oil cooler (Para L-29).

**END OF TASK**



**L-46. ENGINE REPAIR (FAN HUB MAINTENANCE).**

This Task Covers:

- a. Disassembly
- b. Inspection
- c. Assembly
- d. Follow-On Maintenance

**INITIAL SETUP**

*Test Equipment*  
None

*References*  
None

*Tools and Special Tools*  
Tool kit, common no. 2, Item 36, Appendix B  
Tool kit, general mechanics, Item 38, Appendix B

*Equipment Conditions*  
*TM or Para*      *Condition Description*  
Para L-10      Fan hub removed.

*Materials/Parts*  
None

*Drawings Required*  
TM 5-2420-230-24P Figure 27

*Personnel Required*  
MOS 62B, Construction Equipment Repairer

*Estimated Time to Complete Task*  
Refer to MAC in Appendix B

**a. Disassembly.**

Refer to page L-396 for disassembly.

**b. Inspection.**

Refer to page L-396 for inspection.

**c. Assembly.**

Refer to page L-397 for assembly.

**d. Follow-On Maintenance.**

Install fan hub (Para L-10).

**END OF TASK**



**L-48. ENGINE REPAIR (MECHANICAL TACHOMETER DRIVE COVER REPLACEMENT).**

This Task Covers:

- a. Removal
- b. Installation
- c. Follow-On Maintenance

**INITIAL SETUP**

*Test Equipment*  
None

*References*  
None

*Tools and Special Tools*  
Tool kit, general mechanics, Item 38, Appendix B

*Equipment Conditions*  

<i>TM or Para</i> Para L-22	<i>Condition Description</i> Front cover removed.
--------------------------------	--

*Materials/Parts*  
Gasket, Item 63, Appendix D

*Drawings Required*  
TM 5-2420-230-24P Figure 19

*Personnel Required*  
MOS 62B, Construction Equipment Repairer

*Estimated Time to Complete Task*  
Refer to MAC in Appendix B

**a. Removal.**

Remove mechanical tachometer drive cover (1) and gasket (2) from gear housing (3). Discard gasket.

**b. Installation.**

Install new gasket (2) and mechanical tachometer drive cover (1) to gear housing (3).

**c. Follow-On Maintenance.**

Install front cover (Para L-22).

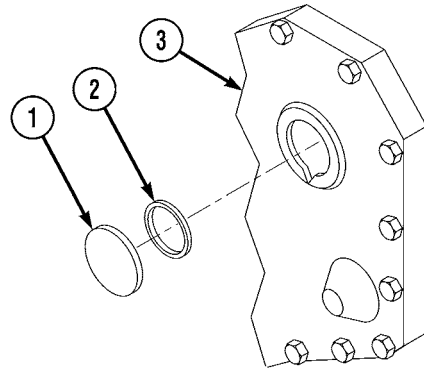

**END OF TASK**

ME1230

**L-49. IDLE ADJUSTMENT.**

This Task Covers:

- a. Adjustment
- b. Follow-On Maintenance

**INITIAL SETUP**

<i>Test Equipment</i> None	<i>Equipment Conditions</i> <i>TM or Para</i> TM 5-2420-230-10	<i>Condition Description</i> Vehicle positioned on level ground.
<i>Tools and Special Tools</i> Tool kit, general mechanics, Item 38, Appendix B	TM 5-2420-230-10 TM 5-2420-230-10	Parking brake applied. Engine shut OFF.
<i>Materials/Parts</i> None	TM 5-2420-230-10 TM 5-2420-230-10	Electrical master switch OFF. “Do Not Operate” tag attached to ignition switch.
<i>Personnel Required</i> MOS 62B, Construction Equipment Repairer	TM 5-2420-230-10	Hood raised.
<i>References</i> None	<i>Drawings Required</i> None	
	<i>Estimated Time to Complete</i> Refer to MAC in Appendix B	

**a. Adjustment.**

Refer to page L-916 for idle adjustment.

**b. Follow-On Maintenance.**

- (1) Shut OFF engine (TM 5-2420-230-10).
- (2) Remove “Do Not Operate” tag from ignition switch (TM 5-2420-230-10).
- (3) Close engine hood and attach clips (TM 5-2420-230-10).

**END OF TASK**

## **Section II. Vendor Service Manual.**

Section II contains information for servicing the engine in the form of the manufacturer's technical manual which follows this page. Section III contains information for troubleshooting the engine in the form of the manufacturer's technical manual. Section I contains U.S. Army supplemental information to the vendor manuals.





**B Series  
Shop Manual  
1991 and 1994  
Certification Levels**



# B Series Shop Manual 1991 and 1994 Certification Levels

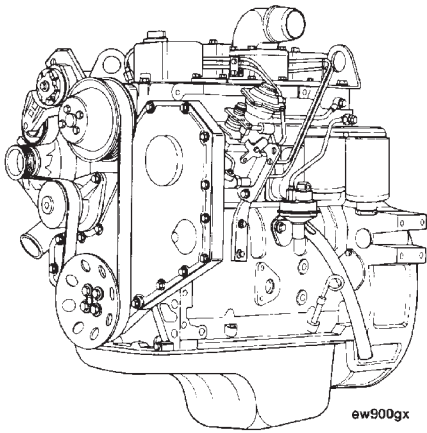

**Four Cylinder  
4BT3.9**

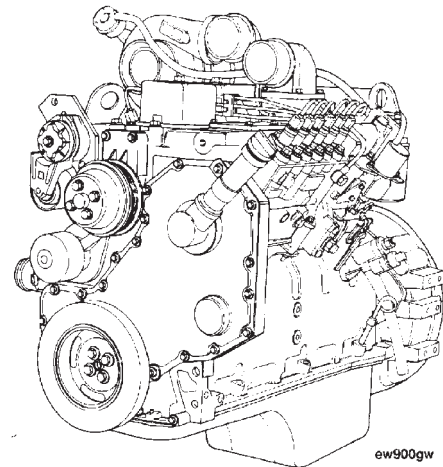

**Six Cylinder  
6BT5.9**

Copyright© 1994  
Cummins Engine Company, Inc.  
All rights reserved

Bulletin 3666017-01  
Printed in U.S.A. 11/94 (996)



## Foreword

This manual contains complete rebuild specifications and information for the B Series engines, and all associated components manufactured by Cummins Engine Company, Inc. A listing of accessory and component suppliers' addresses and telephone numbers is located in Section C. Suppliers can be contacted directly for any information **not** covered in this manual.

**Read and follow all safety instructions. Refer to the WARNING in the General Safety Instructions in this section.**

The repair procedures in this manual are based on the engine being installed on an approved engine stand. Some rebuild procedures require the use of special service tools. Make sure the correct tools are used as described in the procedures.

When a specific brand name, number, or special tool is referenced in this manual, an equivalent product can be used in place of the recommended item.

A series of specific service manuals (Troubleshooting and Repair, Specifications, Alternative Repair, and so on.) are available and can be ordered by filling out and mailing the Literature Order Form located in the Service Literature Section L.

Reporting of errors, omissions, and recommendations for improving this publication by the user is encouraged. Please use the postage paid, self-addressed Literature Survey Form in the back of this manual for communicating your comments.

The specifications and rebuild information in this manual is based on the information in effect at the time of printing. Cummins Engine Company, Inc. reserves the right to make any changes at any time without obligation. If differences are found between your engine and the information in this manual, contact a Cummins Authorized Repair Location, a Cummins Division Office, or the factory.

The latest technology and the highest quality components are used to manufacture Cummins engines. When replacement parts are needed, we recommend using only genuine Cummins or ReCon® exchange parts. These parts can be identified by the following trademarks:



# Table of Contents

	<b>Page</b>
Introduction.....	i-1
Engine Identification.....	E-1
Engine Disassembly and Assembly – Group 00 .....	0-1
Cylinder Block – Group 01 .....	1-1
Cylinder Head – Group 02 .....	2-1
Rocker Levers – Group 03.....	3-1
Cam Followers – Group 04.....	4-1
Fuel System – Group 05 .....	5-1
Injectors and Fuel Lines – Group 06 .....	6-1
Lubricating Oil System – Group 07.....	7-1
Cooling System – Group 08.....	8-1
Drive Units – Group 09.....	9-1
Air Intake System – Group 10 .....	10-1
Exhaust System – Group 11.....	11-1
Air Equipment – Group 12 .....	12-1
Electrical Equipment – Group 13.....	13-1
Engine Testing – Group 14 .....	14-1
Mounting Adaptations – Group 16.....	16-1
Specifications – Group 18 .....	18-1
Service Literature.....	L-1
Component Manufacturers: Names and Addresses .....	C-1
Index .....	X-1

# Cummins 22-Group System Exploded Diagram

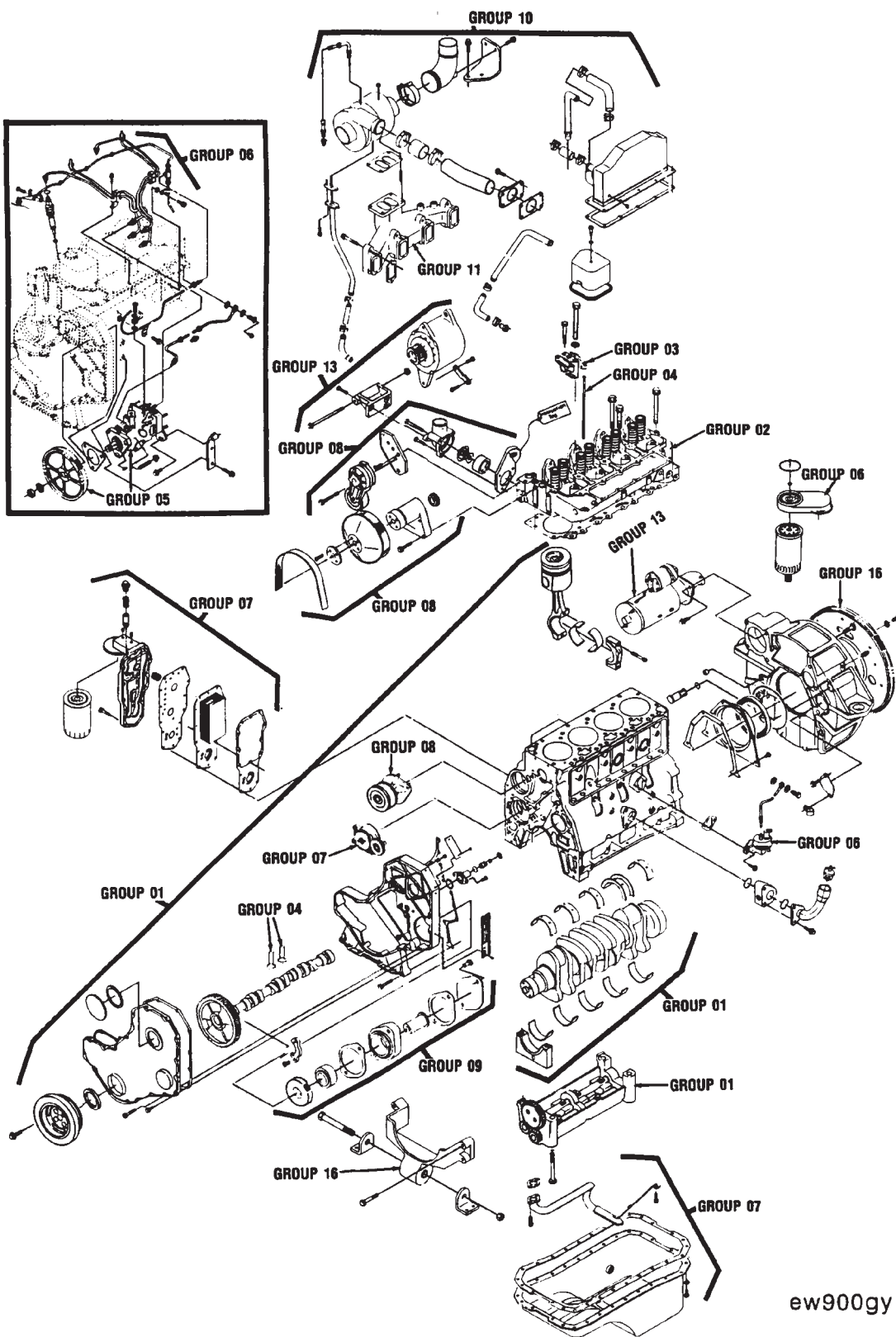

ew900gy

# Section i - Introduction

## Section Contents

	<b>Page</b>
<b>About the Manual</b> .....	i-2
<b>General Cleaning Instructions</b> .....	i-11
Glass or Plastic Bead Cleaning.....	i-11
Solvent and Acid Cleaning .....	i-11
Steam Cleaning .....	i-11
<b>General Repair Instructions</b> .....	i-10
<b>General Safety Instructions</b> .....	i-9
Important Safety Notice .....	i-9
<b>Generic Symbols</b> .....	i-4
<b>Glossary of Terms</b> .....	i-12
<b>How To Use The Manual</b> .....	i-3
Group Contents .....	i-3
Index.....	i-3
Metric Information .....	i-3
Table of Contents.....	i-3
<b>Illustrations</b> .....	i-8
<b>Simbolos Usados En Este Manual</b> .....	i-5
<b>Symbole</b> .....	i-6
<b>Symboles Utilises Dans Ce Manuel</b> .....	i-7

## About the Manual

This manual contains information for 1991 and newer engines starting with ESN 44566920. For information on prior built engines refer to the B Series Shop Manual, Bulletin No. 3810206-02.

The procedures in this manual were developed for a shop environment with engine disassembly and assembly being performed on a rollover stand. A Group System has been used to subdivide the instructions by major components and systems. Refer to the Table of Contents (page i-1) for the various groups. The information is presented in very basic terms to make sure the instructions are easily understood. Wrench sizes and shop tooling are identified in the procedure when needed.

Each group contains the following in sequence:

- An Alphabetical Table of Contents (Index).
- Exploded view(s) of all the components in the group.
- General Information Section(s) containing the basic service, maintenance, and design information necessary to assist in the rebuild of the engine or a component.
- Procedural instructions for the disassembly, inspection, repair, and assembly that can be required to rebuild an engine. Additional repairs that are not essential during every rebuild, but can be necessary, are included. These repairs depend on the length of time an engine has been in service and the condition of the parts.

## How To Use The Manual

All references to engine components in this manual are divided into 22 specific groups. The organization is consistent with the service bulletins, service parts topics, and the parts catalogs for your convenience in updating the shop manual.

### Table of Contents

The Table of Contents in the front of the manual contains a quick page reference for each group number.

### Group Contents

Each group contains the following information:

- A group index page at the beginning of each group to quickly aid in locating the information desired.
- General information to aid in rebuilding the component and an explanation of design change differences.
- Step-by-step rebuild instructions for disassembly, cleaning, inspection, and assembly of the component.
- Symbols which represent the action outlined in the instructions. The definitions of the symbols, listed in four languages (English, Spanish, French, and German), appear on pages i-5 through i-8.

### Index

An alphabetical index is in the back of the manual to aid in locating specific information.

### Metric Information

Both metric and U.S. customary values are used in this manual. The metric value is listed first, followed by the U.S. customary in brackets. An example is 60°C [140°F].

## Generic Symbols

The following group of symbols have been used in this manual to help communicate the intent of the instructions. When one of the symbols appears, it conveys the meaning defined below.



**WARNING** - Serious personal injury or extensive property damage can result if the warning instructions are not followed.



**CAUTION** - Minor personal injury can result or a part, an assembly or the engine can be damaged if the caution instructions are not followed.



Indicates a **REMOVAL** or **DISASSEMBLY** step.



Indicates an **INSTALLATION** or **ASSEMBLY** step.



**INSPECTION** is required.



**CLEAN** the part or assembly.



**PERFORM** a mechanical or time **MEASUREMENT**.



**LUBRICATE** the part or assembly.



Indicates that a **WRENCH** or **TOOL SIZE** will be given.



**TIGHTEN** to a specific torque.



**PERFORM** an electrical **MEASUREMENT**.



Refer to another location in this manual or another publication for additional information.



The component weighs 23 kg [50 lb] or more. To avoid personal injury, use a hoist or get assistance to lift the component.

## Simbolos Usados En Este Manual

Los símbolos siguientes son usados en este manual para clarificar el proceso de las instrucciones. Cuando aparece uno de estos símbolos, su significado se especifica en la parte inferior.



**ADVERTENCIA** - Serios daños personales o daño a la propiedad puede resultar si las instrucciones de Advertencia **no** se consideran.



**PRECAUCION** - Daños menores pueden resultar, o de piezas del conjunto o el motor puede averiarse si las instrucciones de Precaución **no** se siguen.



Indica un paso de **REMOCION** o **DESMONTAJE**.



Indica un paso de **INSTALACION** o **MONTAJE**.



Se requiere **INSPECCION**.



**LIMPIESE** la pieza o el montaje.



**EJECUTESE** una **MEDICION** mecánica o del tiempo.



**LUBRIQUESE** la pieza o el montaje.



Indica que se dará una **LLAVE DE TUERCAS** o el **TAMAÑO DE HERRAMIENTA**.



**APRIETESE** hasta un par torsor específico.



**EJECUTESE** una **MEDICION** eléctrica.



Para información adicional refiérase a otro emplazamiento de este manual o a otra publicación anterior.



## Symbole

In diesem Handbuch werden die folgenden Symbole verwendet, die wesentliche Funktionen hervorheben. Die Symbole haben folgende Bedeutung:



**WARNUNG** - Wird die Warnung **nicht** beachtet, dann besteht erhöhte Unfall- und Beschädigungsgefahr.



**VORSICHT** - Werden die Vorsichtsmassnahmen **nicht** beachtet, dann besteht Unfall- und Beschädigungsgefahr.



**AUSBAU** bzw. **ZERLEGEN**.



**EINBAU** bzw. **ZUSAMMENBAU**.



**INSPEKTION** erforderlich.



Teil oder Baugruppe **REINIGEN**.



**DIMENSION** - oder **ZEITMESSUNG**.



Teil oder Baugruppe **ÖLEN**.



**WERKZEUGGRÖSSE** wird angegeben.



**ANZUG** auf vorgeschriebenes Drehmoment erforderlich.



Elektrische **MESSUNG DURCHFÜHREN**.



Weitere Informationen an anderer Stelle bzw. in anderen Handbüchern.

## Symboles Utilises Dans Ce Manuel

Les symboles suivants sont utilisés dans ce manuel pour aider à communiquer le but des instructions. Quand l'un de ces symboles apparaît, il évoque le sens défini ci-dessous:



**AVERTISSEMENT** - De graves lésions corporelles ou des dommages matériels considérables peuvent survenir si les instructions données sous les rubriques "Avertissement" **ne** sont **pas** suivies.



**ATTENTION** - De petites lésions corporelles peuvent survenir, ou bien une pièce, un ensemble ou le moteur peuvent être endommagés si les instructions données sous les rubriques "Attention" **ne** sont **pas** suivies.

sécurité p



Indique une opération de **DEPOSE**.



Indique une opération de **MONTAGE**.



**L'INSPECTION** est nécessaire.



**NETTOYER** la pièce ou l'ensemble.



**EFFECTUER** une **MESURE** mécanique ou de temps.



**GRAISSER** la pièce ou l'ensemble.



Indique qu'une **DIMENSION DE CLE** ou **D'OUTIL** sera donnée.



**SERRER** à un couple spécifique.



**EFFECTUER** une **MESURE** électrique.



Se reporter à un autre endroit dans ce manuel ou à une autre publication pour obtenir des informations plus complètes.

### Illustrations

The illustrations used in the "Repair Sections" of this manual are intended to give an example of a problem, and to show what to look for and where the problem can be found. Some of the illustrations are "generic" and might **not** look exactly like the engine or parts used in your application. The illustrations can contain symbols to indicate an action required, and an acceptable or **not** acceptable condition.

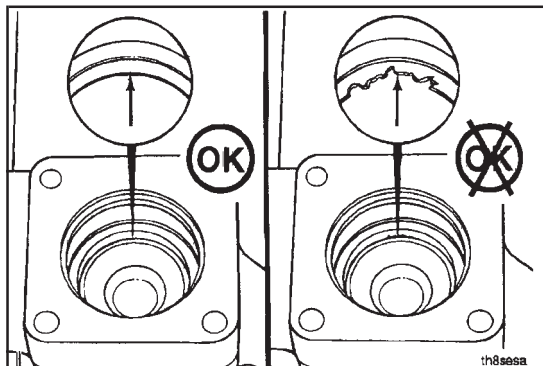

The illustrations are intended to show repair or replacement procedures. The illustration can differ from your application, but the procedure given will be the same.

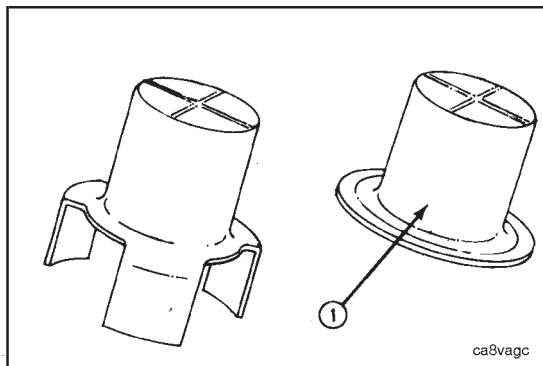

## General Safety Instructions

### Important Safety Notice



**Improper practices or carelessness can cause burns, cuts, mutilation, asphyxiation or other bodily injury or death.**

Read and understand all of the safety precautions and warnings before performing any repair. This list contains the general safety precautions that **must** be followed to provide personal safety. Special safety precautions are included in the procedures when they apply.

- Make sure the work area surrounding the product is dry, well lit, ventilated; free from clutter, loose tools, parts, ignition sources and hazardous substances. Be aware of hazardous conditions that can exist.
- **Always** wear protective glasses and protective shoes when working.
- Rotating parts can cause cuts, mutilation or strangulation.
- Do **not** wear loose-fitting or torn clothing. Remove all jewelry when working.
- Disconnect the battery (negative [-] cable first) and discharge any capacitors before beginning any repair work. Disconnect the air starting motor if equipped to prevent accidental engine starting. Put a “Do **Not** Operate” tag in the operator’s compartment or on the controls.
- Use **ONLY** the proper engine barring techniques for manually rotating the engine. Do **not** attempt to rotate the crankshaft by pulling or prying on the fan. This practice can cause serious personal injury, property damage, or damage to the fan blade(s) causing premature fan failure.
- If an engine has been operating and the coolant is hot, allow the engine to cool before you slowly loosen the filler cap and relieve the pressure from the cooling system.
- Do **not** work on anything that is supported **ONLY** by lifting jacks or a hoist. **Always** use blocks or proper stands to support the product before performing any service work.
- Relieve all pressure in the air, oil, and the cooling systems before any lines, fittings, or related items are removed or disconnected. Be alert for possible pressure when disconnecting any device from a system that utilizes pressure. Do **not** check for pressure leaks with your hand. High pressure oil or fuel can cause personal injury.
- To prevent suffocation and frostbite, wear protective clothing and **ONLY** disconnect liquid refrigerant (freon) lines in a well ventilated area. To protect the environment, liquid refrigerant systems **must** be properly emptied and filled using equipment that prevents the release of refrigerant gas (fluorocarbons) into the atmosphere. Federal law requires capture and recycling refrigerant.
- To avoid personal injury, use a hoist or get assistance when lifting components that weigh 23 kg [50 lb] or more. Make sure all lifting devices such as chains, hooks, or slings are in good condition and are of the correct capacity. Make sure hooks are positioned correctly. **Always** use a spreader bar when necessary. The lifting hooks **must not** be side-loaded.
- Corrosion inhibitor contains alkali. Do **not** get the substance in your eyes. Avoid prolonged or repeated contact with skin. Do **not** swallow internally. In case of contact, immediately wash skin with soap and water. In case of contact, immediately flood eyes with large amounts of water for a minimum of 15 minutes. **IMMEDIATELY CALL A PHYSICIAN. KEEP OUT OF REACH OF CHILDREN.**
- Naptha and Methyl Ethyl Ketone (MEK) are flammable materials and **must** be used with caution. Follow the manufacturer’s instructions to provide complete safety when using these materials. **KEEP OUT OF REACH OF CHILDREN.**
- To avoid burns, be alert for hot parts on products that have just been turned OFF, and hot fluids in lines, tubes, and compartments.
- **Always** use tools that are in good condition. Make sure you understand how to use them before performing any service work. Use **ONLY** genuine Cummins or Cummins Recon® replacement parts.
- **Always** use the same fastener part number (or equivalent) when replacing fasteners. Do **not** use a fastener of lesser quality if replacements are necessary.
- Do **not** perform any repair when fatigued or after consuming alcohol or drugs that can impair your functioning.
- Some state and federal agencies in the United States of America have determined that used engine oil can be carcinogenic and can cause reproductive toxicity. Avoid inhalation of vapors, ingestion, and prolonged contact with used engine oil.

## General Repair Instructions

This engine incorporates the latest diesel technology at the time it was manufactured; yet, it is designed to be repaired using normal repair practices performed to quality standards.

- **Cummins Engine Company, Inc. does not recommend or authorize any modifications or repairs to engines or components except for those detailed in Cummins Service Information. In particular, unauthorized repair to safety-related components can cause personal injury or death. Below is a partial listing of components classified as safety-related:**

- Air Compressor
- Air Controls
- Air Shutoff Assemblies
- Balance Weights
- Cooling Fan
- Fan Hub Assembly
- Fan Mounting Bracket(s)
- Fan Mounting Capscrews
- Fan Hub Spindle
- Flywheel
- Flywheel Crankshaft Adapter
- Flywheel Mounting Capscrews
- Fuel Shutoff Assemblies
- Fuel Supply Tubes
- Lifting Brackets
- Throttle Controls
- Turbocharger Compressor Casing
- Turbocharger Oil Drain Line(s)
- Turbocharger Oil Supply Line(s)
- Turbocharger Turbine Casing
- Vibration Damper Mounting Capscrews

- **Follow All Safety Instructions Noted in the Procedures.**
  - Follow the manufacturer's recommendations for cleaning solvents and other substances used during the repair of the engine. Some solvents and used engine oil have been identified by government agencies as toxic or carcinogenic. Avoid excessive breathing, ingestion and contact with such substances. **Always** use good safety practices with tools and equipment.
- **Provide A Clean Environment and Follow the Cleaning Instructions Specified in the Procedures**
  - The engine and its components **must** be kept clean during any repair. Contamination of the engine or components will cause premature wear.
- **Perform the Inspections Specified in the Procedures.**
- **Replace all Components or Assemblies Which are Damaged or Worn Beyond the Specifications**
- **Use Genuine Cummins New or ReCon® Service Parts and Assemblies**
  - The assembly instructions have been written to use again as many components and assemblies as possible. When it is necessary to replace a component or assembly, the procedure is based on the use of new Cummins or Cummins ReCon® components. All of the repair services described in this manual are available from all Cummins Distributors and most Dealer locations.
- **Follow The Specified Disassembly and Assembly Procedures to Avoid Damage to the Components.**

Complete rebuild instructions are available in the shop manual which can be ordered or purchased from a Cummins Authorized Repair Location. Refer to Section L, Literature, for ordering instructions.

## General Cleaning Instructions

### Solvent and Acid Cleaning

Several solvent and acid-type cleaners can be used to clean the engine parts. **Cummins Engine Company, Inc. does not recommend any specific cleaners. Always** follow the cleaner manufacturer's instructions.

Experience has shown that the best results can be obtained using a cleaner that can be heated to 90 to 95 degrees Celsius [180 to 200 degrees Fahrenheit]. A cleaning tank that provides a constant mixing and filtering of the cleaning solution will give the best results.



Remove all the gasket material, o-rings, and the deposits of sludge, carbon, etc., with a wire brush or scraper before putting the parts in a cleaning tank. Be careful **not** to damage any gasket surfaces. When possible, steam clean the parts before putting them in the cleaning tank.



**Warning: Acid is extremely dangerous, and can damage the machinery. Always provide a tank of strong soda water as a neutralizing agent.**

Rinse all of the parts in hot water after cleaning. Dry completely with compressed air. Blow the rinse water from all of the capscrew holes and the oil drillings.

If the parts are **not** to be used immediately after cleaning, dip them in a suitable rustproofing compound. The rustproofing compound **must** be removed from the parts before installation on the engine.

### Steam Cleaning

Steam cleaning can be used to remove all types of dirt that can contaminate the cleaning tank. It is a good way to clean the oil drillings.



**Warning: Wear protective clothing to prevent personal injury from the high pressure and extreme heat.**

Do **not** steam clean the following parts:



1. Electrical Components
2. Wiring
3. Injectors
4. Fuel Pump
5. Belts and Hoses
6. Bearings

### Glass or Plastic Bead Cleaning

Glass or plastic bead cleaning can be used on many engine components to remove carbon deposits. The cleaning process is controlled by the size of the glass or plastic beads, the operating pressure, and the cleaning time.



**Caution: Do not use glass or plastic bead cleaning on aluminum piston skirts. Do not use glass bead cleaning on aluminum ring grooves. Small particles of glass or plastic will embed in the aluminum and result in premature wear. Valves, turbocharger shafts, etc., can also be damaged. Follow the cleaning directions listed in the procedures.**



**NOTE:** Plastic bead blasting media, Part No. 3822735, can be used to clean aluminum ring grooves. Do **not** use any bead blasting media on pin bores or aluminum skirts.

Follow the equipment manufacturer's cleaning instructions. The following guidelines can be used to adapt to manufacturer's instructions:

1. Bead size:
  - Use U.S. size No. 16-20 for piston cleaning with plastic bead media, Part No. 3822735.
  - Use U.S. size No. 70 for piston domes with glass media.
  - Use U.S. size No. 60 for general purpose cleaning with glass media.
2. Operating Pressure:
  - Glass: Use 620 kPa [90 psi] for general purpose cleaning.
  - Plastic: Use 270 kPa [40 psi] for piston cleaning.
3. Steam clean or wash the parts with solvent to remove all of the foreign material and glass or plastic beads after cleaning. Rinse with hot water. Dry with compressed air.
4. Do **not** contaminate the wash tanks with glass or plastic beads.

## Glossary of Terms

### Definition

A.C.:	Alternating Current
AFC:	Air Fuel Control; a device in the fuel pump that limits the fuel delivery until there is sufficient intake manifold pressure to allow for complete combustion.
ATDC:	After Top Dead Center; refers to the position of the piston or the crankshaft rod journal. The piston is moving downward on the power stroke or intake stroke.
BDC:	Bottom Dead Center; refers to the position of the piston or the crankshaft rod journal. The piston is at its lowest position in the cylinder.
BTDC:	Before Top Dead Center; refers to the position of the piston or the crankshaft rod journal. The piston is moving upward on the compression stroke or exhaust stroke.
Circumferential Direction:	In the direction of a circle in respect to the centerline of a round part or a bore.
Concentricity:	A measurement of the <b>difference</b> between the centers of <b>either</b> two or more parts <b>or the bores in one part</b> .
CPL:	Control Parts List; this listing identifies the specific parts that <b>must</b> be installed on the engine to meet agency certification.
Cummins Sealant:	This is a one part Room Temperature Vulcanizing (RTV) silicone rubber, adhesive and sealant material having <b>high</b> heat and oil resistance, and <b>low</b> compression set. Some of the equivalent products are Marston Lubricants, Hylosil, Dow Corning, Silastic 732, Loctite Superflex, General Electric 1473, and General Electric 1470.
D.C.:	Direct Current
Dye Penetrant Method:	A method used to check for cracks in a part by using a dye penetrant and a developer. Use crack detection kit, Part No. 3375432, or its equivalent.
End Clearance:	The clearance in an assembly determined by pushing the shaft in an axial direction <b>one way</b> and then pushing the shaft the <b>other way</b> .
E.S.N.	Engine Serial Number
Hammer:	A hand tool consisting of a hard steel head on a handle.
I.D.:	Inside Diameter
Loctite 290:	A single component, anaerobic, polyester resin, liquid sealant compound that hardens between closely fitted metal surfaces producing a tough, hard bond. An equivalent product is Perma-Lok HL 126.
Loctite 609:	A single component anaerobic, liquid adhesive that meets or exceeds the requirements of MIL-R-46082A (MR) TYPE1. Some of the equivalent products are Loctite 601 and Permabond HL 138.
Lubriplate 105:	A mineral oil base grease with calcium soap (2 percent to 6 percent), and zinc oxide (2 percent to 4 percent) additives.

	<b>Definition</b>
Magnetic Particle Inspection:	A method of checking for cracks in <b>either</b> steel <b>or</b> iron parts. This method requires a Magnaflux or equivalent machine that imparts a magnetic field on the part being checked.
Mallet:	A hand tool consisting of a soft head, <b>either</b> wood, plastic, lead, brass, <b>or</b> rawhide, on a handle.
MAX:	Maximum allowed
MIN:	Minimum allowed
No.:	Number
O.D.:	Outside Diameter
OS:	Oversize
Protrusion:	The <b>difference</b> in the height between two parts in the assembled state.
STD:	Standard
TC:	Torque Converter; used when referring to the torque converter cooler.
TDC:	Top Dead Center; refers to the position of the piston or the crankshaft rod journal. The piston is at its highest position in the cylinder. The rod journal is pointing straight up toward the piston.
T.I.R.:	Total Indicator Runout; used when measuring the concentricity or the runout. The T.I.R. refers to the total movement of the needle on a dial indicator, from the most <b>negative</b> reading to the most <b>positive</b> reading.
Water Pump Grease:	A premium high temperature grease that will lubricate antifriction bearings continually from <b>minus</b> 40°C [ <b>minus</b> 40°F] to <b>plus</b> 150°C [Plus 350°F]. Some of the greases meeting this requirement are Aeroshell No. 5, Chevron SRI, Amoco Rykon Premijm No. 2, Texaco Premium RB, and Shell Dolium R. Aeroshell No. 5 is <b>not</b> compatible with the other greases and <b>must not</b> be mixed. Cummins Engine Company, Inc., uses Aeroshell No. 5 on new engines and components.





# Section E - Engine and Component Identification

## Section Contents

	Page
<b>Engine Diagram - Automotive Engine</b> .....	E-9
<b>Engine Identification</b> .....	E-2
Automotive Engine Dataplate .....	E-2
Automotive Engine Nomenclature .....	E-3
Engine Dataplate .....	E-2
Industrial Engine Nomenclature .....	E-3
<b>General Engine Specifications</b> .....	E-6
Batteries (Specific Gravity) .....	E-8
Cooling System .....	E-7
Electrical System .....	E-8
Fuel System .....	E-7
General Engine Data .....	E-6
Intake Air and Exhaust System .....	E-7
Lubrication System .....	E-6
<b>Injection Pump Dataplate</b> .....	E-4
Lucas CAV DPA dataplate location .....	E-4
Robert Bosch VE dataplate location .....	E-4

### Engine Identification

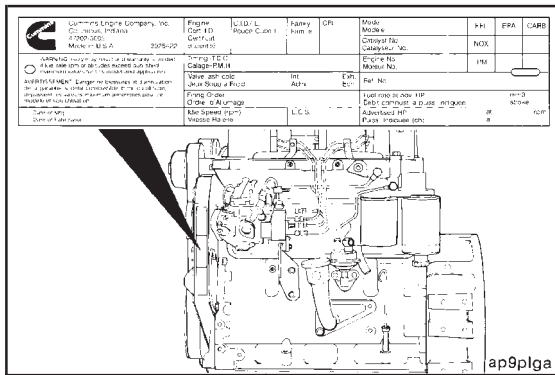

### Engine Dataplate

The engine dataplates show specific information about your engine. The engine serial number (1) and Control Parts List (CPL) (2) provide information for ordering parts and servicing the engine.

**NOTE:** The engine dataplate **must not** be changed unless approved by Cummins Engine Company, Inc.

Cummins Engine Company, Inc. Columbus, Indiana 47262-3005 Made in U.S.A.	Engine Cert. I.D. Certificat d'identite	C.I.D. / L. Prouce Cube/L	Family Famille	CPL <span style="position: absolute; top: -10px; left: 10px;">2</span>	Model Modele	FEL	EPA	CARB
	Timing-T.D.C. Calage-PM.H.	Engine No. Moteur No.	Catalyst No. Catalyseur No.	NOX	PM	Ref. No.		
Valve lash cold Jeux Soup. à Froid	Int. Adm.	Exh. Ech.				Fuel rate at adv. HP Débit combust. à puss. indiquée	mm <sup>3</sup> stroke	
Firing Order Ordre d'Allumage	Idle Speed (rpm) Vitesse Palens	E.C.S.				Adverssed HP Puss. Indiquée (ch)	at a	rpm
Date of Mfg Date de Fabrication								

ap9plgb

### Automotive Engine Dataplate

### Industrial Engine Nomenclature

The model name for Industrial engines provides the following engine data:

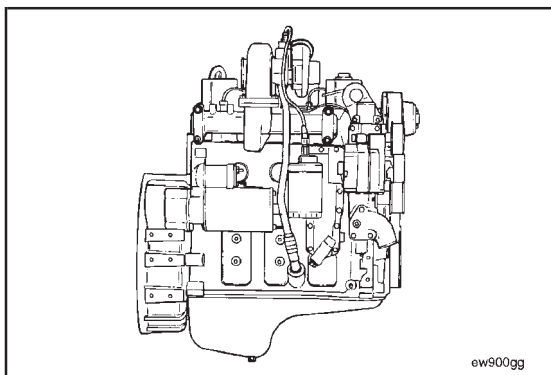
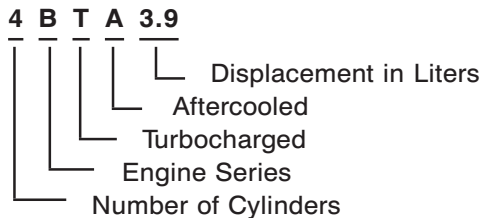

### Automotive Engine Nomenclature

The model name for Automotive engines provides the following engine data:

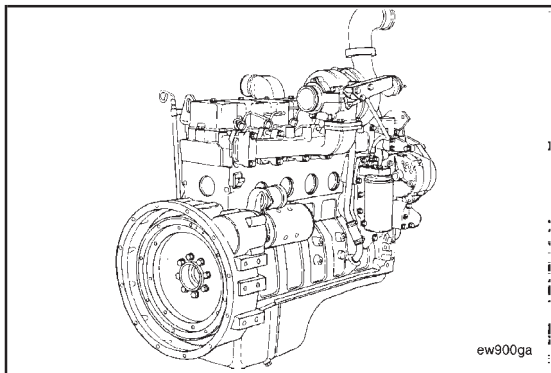
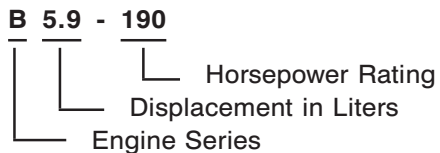

Injection Pump Dataplate  
Page E-4

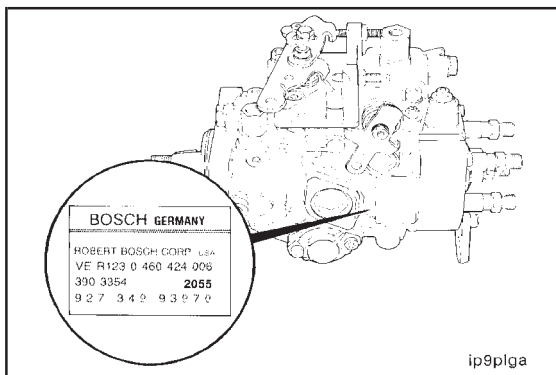

**Injection Pump Dataplate**

The injection pump dataplate is located on the side of the injection pump. It provides information for fuel pump calibration.

**Robert Bosch VE dataplate location.**

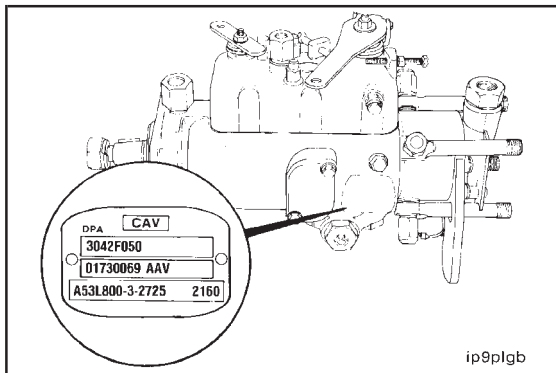

**Lucas CAV DPA dataplate location.**

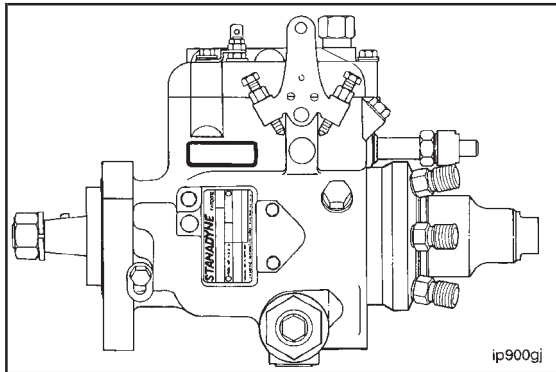

**Stanadyne DB4 Dataplate Location**

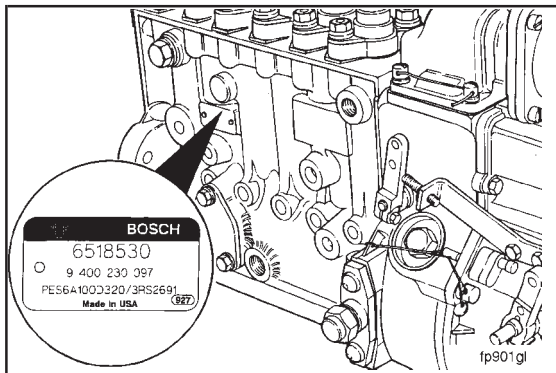

**In-Line Injection Pump Dataplate Location**

This illustration shows the dataplate location for the Bosch and Nippondenso in-line injection pump.

Section E - Engine and Component Identification  
B Series

The Cummins part number for the fuel pump-governor combination is located on the governor dataplate.

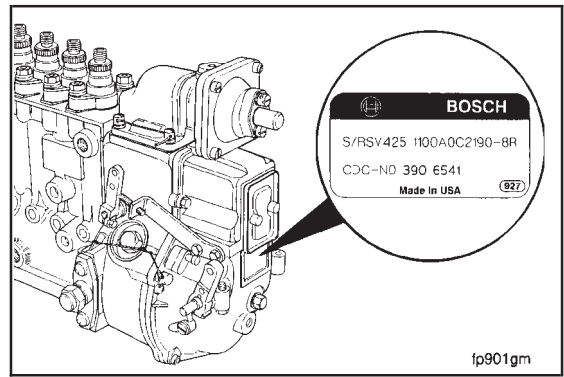

## General Engine Specifications

### General Engine Data

Bore .....	102 mm [4.02 in]
Stroke .....	120 mm [4.72 in]
Displacement	
4B .....	3.92 liters [239 in <sup>3</sup> ]
6B .....	5.88 liters [359 in <sup>3</sup> ]
Compression ratio	
4B3.9/6B5.9 Industrial, naturally aspirated .....	18.5:1
4BT3.9/6BT5.9 Industrial, turbocharged .....	17.5:1
4BTA3.9/6BTA5.9 Industrial, turbocharged and aftercooled .....	16.5:1
B3.9/B5.9* Automotive, charge air cooled .....	17.6:1
Firing order	
6 cylinder .....	1-5-3-6-2-4
4 cylinder .....	1-3-4-2
Valve Settings	
Intake Valve Adjustment .....	0.25 mm [0.010 in]
Exhaust Valve Adjustment.....	0.51 mm [0.020 in]
Engine rotation (viewed from front of engine) .....	Clockwise
Engine weight (with standard accessories)	
4 cylinder engines .....	325 to 350 kg [715 to 770 lb]
6 cylinder engines .....	410 to 440 kg [910 to 970 lb]

### Lubrication System

Oil pressure	
At Idle (minimum allowable) .....	69 kPa [10 psi]
At rated speed (minimum allowable) .....	207 kPa [30 psi]
Regulating valve opening pressure .....	(1991) 449 kPa [65 psi] (1994) 517 kPa [75 psi]
Differential pressure to open oil filter bypass valve .....	(1991) 138 kPa [20 psi] (1994) 172 kPa [25 psi]
Oil capacity of standard engine	
4 cylinder engines .....	9.5 liters [10 U.S. Qts.]
6 cylinder engines .....	14.2 liters [15 U.S. Qts.]
Total system capacity	
4 cylinder engines .....	11.0 liters [11.6 U.S. Qts.]
6 cylinder engines .....	16.4 liters [17.3 U.S. Qts.]

**Cooling System**

Thermostat

Begins to open .....	81°C [181°F]
Fully open .....	95°C [203°F]
Pressure cap for 99°C [210°F] system .....	50 kPa [7 psi]
Pressure cap for 104°C [220°F] system .....	103 kPa [15 psi]
Coolant capacity (engine only)	
4 cylinder (non-aftercooled, charge air cooled)* .....	7.0 liters [7.4 U.S. Qts.]
4 cylinder (jacket water aftercooled) .....	7.9 liters [8.4 U.S. Qts.]
6 cylinder (non-aftercooled, charge air cooled)* .....	9.0 liters [9.5 U.S. Qts.]
6 cylinder (jacket water aftercooled) .....	9.9 liters [10.5 U.S. Qts.]

**Intake Air and Exhaust System**

Maximum allowable intake restriction at rated speed and load (with dirty air filter element)

Naturally Aspirated .....	50.8 cm H <sub>2</sub> O [20 in H <sub>2</sub> O]
Turbocharged .....	63.5 cm H <sub>2</sub> O [25 in H <sub>2</sub> O]
Maximum turbocharger outlet restriction at rated speed and load .....	76.2 mm Hg [3 in Hg]
Maximum exhaust restriction at rated speed and load	
Automotive with oxidation catalyst.....	152.4 mm Hg [6 in Hg]
Automotive .....	114.3 mm Hg [4.5 in Hg]
Industrial .....	76.2 mm Hg [3 in Hg]

**Fuel System**

Fuel transfer pump maximum inlet restriction .....	100 mm Hg [4 in Hg]
Fuel transfer pump output pressure at rated speed	
Distributor fuel injection pumps (maximum) .....	70 kPa [10 psi]
Inline fuel injection pumps (minimum) .....	172 kPa [25 psi]
Fuel filter restriction (maximum pressure drop across filters) .....	35 kPa [5 psi]
Fuel return restriction (maximum) .....	518 mm Hg [20.4 in Hg]

\* All 1991 and 1994 automotive engines with charge air cooling are designated as B3.9 or B5.9.



**Electrical System**

Minimum Recommended Battery Capacity

Light accessories including alternator, power steering pump, and disengaged clutch

12 Volt System

4 cylinder engine .....	625 CCA
6 cylinder engine .....	800 CCA

24 Volt System\*

4 cylinder engine .....	400 CCA
6 cylinder engine .....	400 CCA

Heavy accessories including hydraulic pump and torque converter

12 Volt System

4 cylinder engine .....	800 CCA
6 cylinder engine .....	950 CCA

24 Volt System\*

4 cylinder engine .....	400 CCA
6 cylinder engine .....	475 CCA

\* Per battery (two 12 volt batteries in series) CCA Ratings are based on -18°C [0°F].

**Batteries (Specific Gravity)**

Specific Gravity at 27°C [80°F]	State of Charge
1.260 - 1.280	100%
1.230 - 1.250	75%
1.200 - 1.220	50%
1.170 - 1.190	25%
1.110 - 1.130	Discharged

### Engine Diagram - Automotive Engine

The illustrations which follow show the locations of the major external engine components, the filters, and other service and maintenance points. Some external components will be at different locations for different engine models.

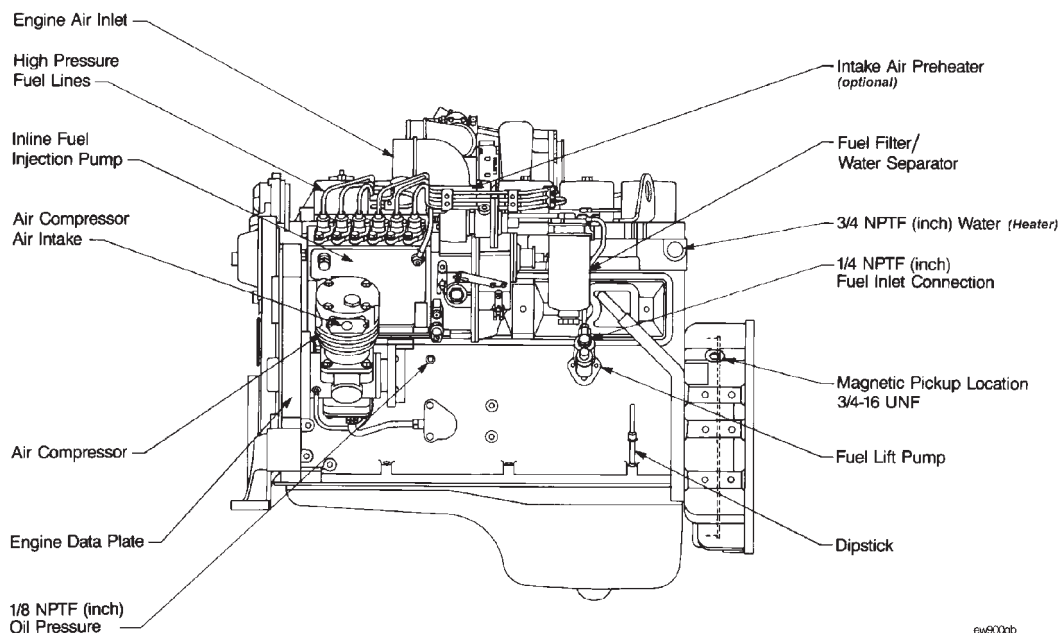

Inlet Side

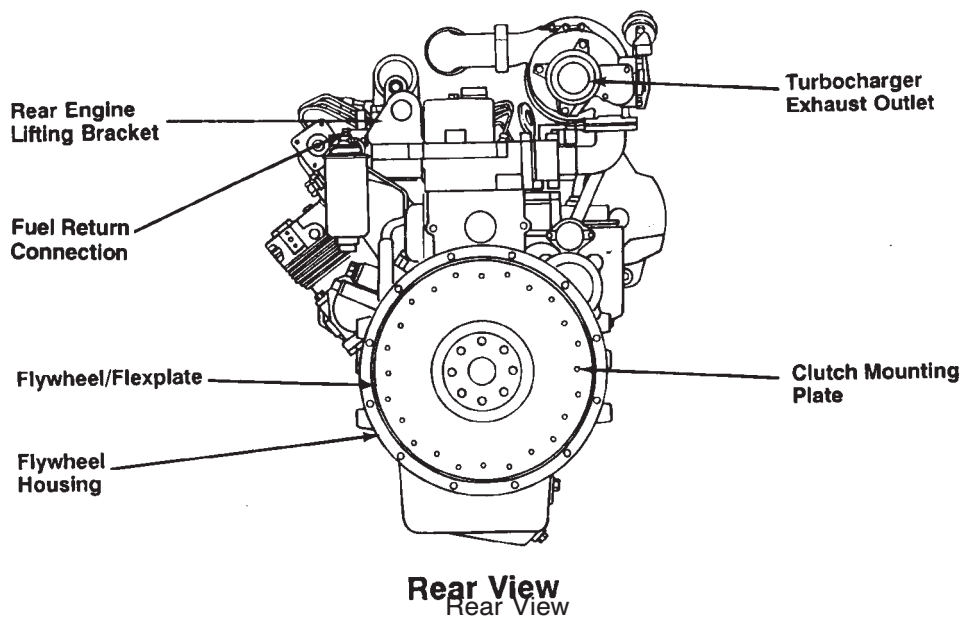

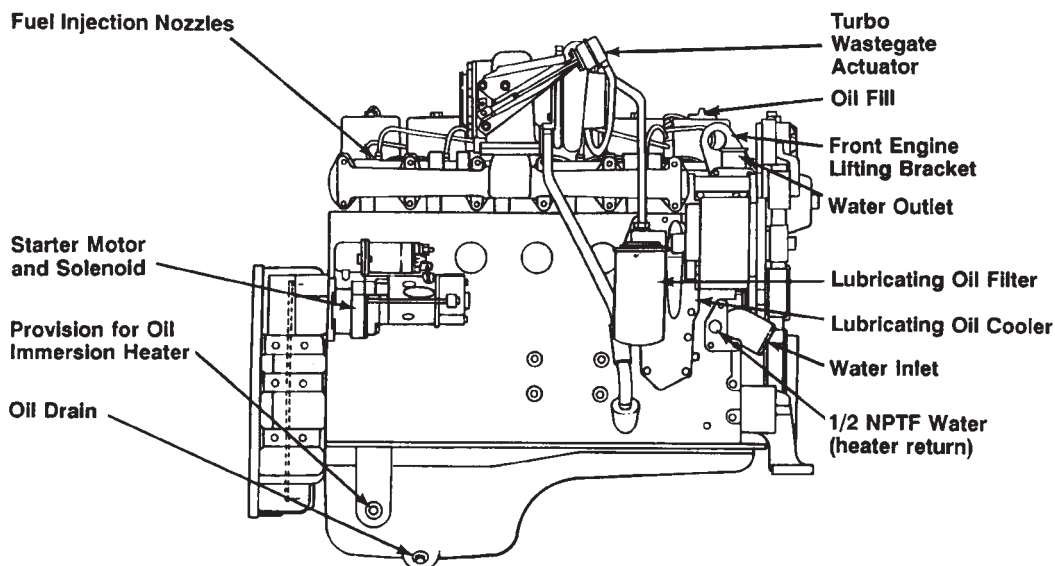

**Turbocharger Side View**

ew900gc

Turbocharger Side View

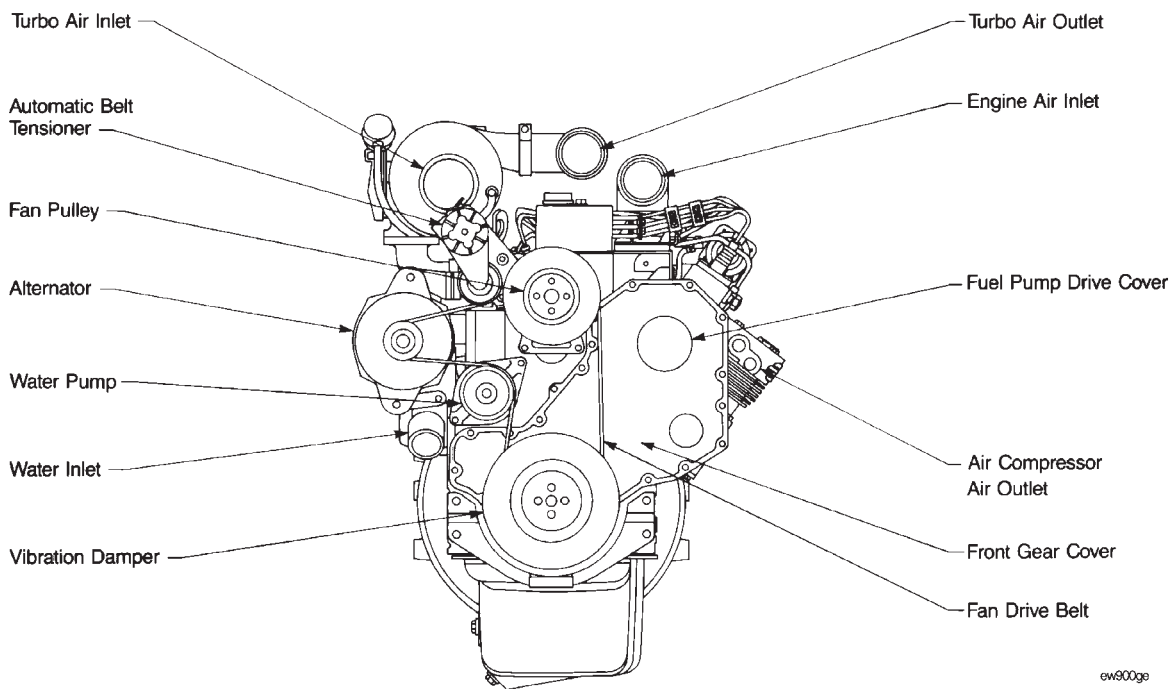

Front View

ew900gc

# Section 0 - Engine Disassembly and Assembly - Group 00

## Section Contents

	Page
<b>Accessories - Installation</b> .....	0-88
<b>Accessories - Removal</b> .....	0-24
<b>Alternator - Installation</b> .....	0-111
<b>Alternator - Removal</b> .....	0-11
<b>Balancer - Installation</b> .....	0-62
<b>Balancer - Removal</b> .....	0-35
Locking the Balancer .....	0-35
Measuring Backlash .....	0-35
Measuring the End Play .....	0-35
Removing the Balancer .....	0-36
<b>Belt Tensioner - Installation</b> .....	0-111
<b>Belt Tensioner - Removal</b> .....	0-10
<b>Camshaft - Installation</b> .....	0-56
Camshaft End Play - Measuring .....	0-58
Camshaft Gear Backlash - Measuring .....	0-59
<b>Camshaft - Removal</b> .....	0-31
Measuring Gear Lash .....	0-31
<b>Crankshaft - Installation</b> .....	0-42
<b>Crankshaft - Removal</b> .....	0-39
<b>Crankshaft End Play - Measuring</b> .....	0-66
<b>Cylinder Block - Prepare for Assembly</b> .....	0-41
<b>Cylinder Block - Removing From the Rollover Stand</b> .....	0-41
<b>Cylinder Head - Installation</b> .....	0-92
<b>Cylinder Head - Removal</b> .....	0-22
<b>Cylinder Head - Tightening</b> .....	0-95
<b>Dipstick - Removal</b> .....	0-19
<b>Drive Belt - Installation</b> .....	0-113
<b>Drive Belt - Removal</b> .....	0-9
<b>Engine Assembly</b> .....	0-41
<b>Engine Disassembly</b> .....	0-8
<b>Engine Disassembly and Assembly</b> .....	0-4
Assembly .....	0-4
Disassembly .....	0-4
General Information .....	0-4
<b>Engine Disassembly and Assembly - Service Tools</b> .....	0-5
<b>Engine Disassembly Check List</b> .....	0-7
<b>Engine Weight</b> .....	0-8
<b>Exhaust Manifold - Installation</b> .....	0-105
<b>Exhaust Manifold - Removal</b> .....	0-14
<b>Fan Hub - Installation</b> .....	0-110
<b>Fan Hub - Removal</b> .....	0-11
<b>Fan Pulley - Removal</b> .....	0-10
<b>Flywheel - Installation</b> .....	0-89

	Page
<b>Flywheel - Removal</b> .....	0-23
<b>Flywheel Housing - Installation</b> .....	0-89
<b>Flywheel Housing - Removal</b> .....	0-23
<b>Front Cover - Installation</b> .....	0-91
<b>Front Cover - Removal</b> .....	0-22
<b>Fuel Filter - Removal</b> .....	0-14
<b>Fuel Filter Head - Installation</b> .....	0-104
<b>Fuel Filter Head - Removal</b> .....	0-15
<b>Fuel Lines - Installation</b> .....	0-101
Fuel Drain Manifold - Installation.....	0-102
High Pressure Fuel Lines - Installation.....	0-103
Injection Pump Supply Line - Installation.....	0-101
Injection Pump Vent Line - Installation.....	0-102
<b>Fuel Lines - Removal</b> .....	0-16
Fuel Drain Manifold - Removal.....	0-17
High Pressure Fuel Line - Removal.....	0-16
Low Pressure Fuel Lines - Removal.....	0-18
<b>Fuel Transfer Pump - Installation</b> .....	0-69
<b>Fuel Transfer Pump - Removal</b> .....	0-28
<b>Gear Housing - Installation</b> .....	0-54
<b>Gear Housing - Removal</b> .....	0-34
<b>Injection Pump - Installation</b> .....	0-71
Injection Pumps - Unlocking.....	0-74
Locked Timed Injection Pump - Installation.....	0-72
Unlocked Bosch VE and P7100 Injection Pump - Installation.....	0-80
Unlocked CAV Injection Pump - Installation.....	0-76
Unlocked Stanadyne DB4 Injection Pump - Installation.....	0-77
<b>Injection Pump - Removal (In-Line)</b> .....	0-26
<b>Injection Pump - Removal (Rotary Type Pumps)</b> .....	0-24
Drive Gear - Removal.....	0-26
Gear Lash - Check.....	0-24
Locking the Pump.....	0-25
<b>Injector Nozzles - Installation</b> .....	0-99
<b>Injector Nozzles - Removal</b> .....	0-20
<b>KSB (Remote Mounted) - Installation</b> .....	0-104
<b>KSB (Remote Mounted) - Removal</b> .....	0-15
<b>Lifting Bracket Removal - Rear</b> .....	0-9
<b>Lube Pump - Installation</b> .....	0-55
<b>Lube Pump - Removal</b> .....	0-32
Measuring Backlash.....	0-32
<b>Manifold Cover - Installation</b> .....	0-100
Aftercooler - Installation.....	0-101
<b>Manifold Cover - Removal</b> .....	0-19
Aftercooler - Removal.....	0-19
<b>Oil - Draining</b> .....	0-9
<b>Oil Cooler - Installation</b> .....	0-69
<b>Oil Cooler - Removal</b> .....	0-29
<b>Oil Filter - Installation</b> .....	0-113
<b>Oil Pan - Installation</b> .....	0-68

	Page
Oil Pan Sealing Surfaces - Sealants .....	0-68
<b>Oil Pan - Removal</b> .....	<b>0-30</b>
<b>Piston and Rod Assemblies - Installation</b> .....	<b>0-47</b>
Piston and Connecting Rod Assemblies - Installation.....	0-50
Piston Grading For 1994 Automotive Applications Only.....	0-47
<b>Piston and Rod Assemblies - Removal</b> .....	<b>0-37</b>
<b>Push Rods - Installation</b> .....	<b>0-93</b>
<b>Push Rods - Removal</b> .....	<b>0-21</b>
<b>Rear Seal - Installation</b> .....	<b>0-66</b>
<b>Rear Seal Housing - Removal</b> .....	<b>0-30</b>
<b>Rocker Levers - Installation</b> .....	<b>0-94</b>
<b>Rocker Levers - Removal</b> .....	<b>0-21</b>
<b>Rollover Stand - Engine Mounting</b> .....	<b>0-8</b>
<b>Rollover Stand - Engine Removal</b> .....	<b>0-113</b>
<b>Side Oil Fill - Installation</b> .....	<b>0-69</b>
<b>Side Oil Fill - Removal</b> .....	<b>0-29</b>
<b>Starter - Installation</b> .....	<b>0-114</b>
<b>Starter - Removal</b> .....	<b>0-8</b>
<b>Steam Cleaning The Engine</b> .....	<b>0-8</b>
<b>Suction Tube - Installation</b> .....	<b>0-67</b>
<b>Suction Tube - Removal</b> .....	<b>0-30</b>
<b>Tappet Cover - Installation</b> .....	<b>0-70</b>
<b>Tappet Cover - Removal</b> .....	<b>0-28</b>
<b>Thermostat - Installation</b> .....	<b>0-109</b>
<b>Thermostat - Removal</b> .....	<b>0-12</b>
<b>Timing Pin - Installation</b> .....	<b>0-59</b>
<b>Timing Pin Housing - Removal</b> .....	<b>0-34</b>
<b>Turbocharger - Installation</b> .....	<b>0-106</b>
<b>Turbocharger - Removal</b> .....	<b>0-12</b>
<b>Turbocharger Drain Tube - Removal</b> .....	<b>0-41</b>
<b>Valve Clearance - Adjustment</b> .....	<b>0-97</b>
<b>Valve Covers - Installation</b> .....	<b>0-100</b>
<b>Valve Covers - Removal</b> .....	<b>0-20</b>
<b>Valve Tappets - Installation</b> .....	<b>0-42</b>
<b>Valve Tappets - Removal</b> .....	<b>0-32</b>
<b>Vibration Damper - Installation</b> .....	<b>0-110</b>
<b>Vibration Damper/Crankshaft Pulley - Removal</b> .....	<b>0-10</b>
<b>Water Inlet Connection - Installation</b> .....	<b>0-111</b>
<b>Water Inlet Connection - Removal</b> .....	<b>0-29</b>
<b>Water Pump - Installation</b> .....	<b>0-90</b>
<b>Water Pump - Removal</b> .....	<b>0-23</b>

## Engine Disassembly and Assembly

### General Information

These procedures apply to all B Series engines. The differences between engine models due to the application, the optional equipment on an engine, and the year an engine was built are included in the instructions. Omit the steps that do **not** apply to the engine being rebuilt.



**Warning:** A **Warning** statement is included for any component or assembly that weighs more than 23 kg [50 lb]. To avoid personal injury, use a hoist or get assistance when **removing** or **installing** these parts.



**Caution:** **All fasteners are specified in metric units. All fasteners have right-hand threads unless a Caution states that a fastener has left-hand threads.**

### Disassembly

The instructions in this procedure are organized in a logical sequence to **disassemble** an engine. This is **not** the **only** sequence to **disassemble** an engine. Certain parts **must** be removed in the sequence indicated. Use this sequence until you become familiar with the engine.

**Discard** all gaskets, seals, hoses, filters, and o-rings. **Keep** these parts if they are needed for a failure analysis.

Label, tag, or mark the parts for location as the parts are removed. This will help identify the parts that can be involved in a failure and will simplify the **assembly** procedure.

Label, tag, mark, or photograph all special equipment prior to the removal from an engine. This engine **assembly** procedure does **not** include the installation of special optional equipment.

Use a mallet when force is required to remove certain parts. Make sure all of the fasteners are removed before using force.

Avoid as much dirt as possible during **disassembly**. The accumulation of additional dirt will make it more difficult to clean the components.

### Assembly

This procedure assumes that all of the components and assemblies have been cleaned, replaced, or rebuilt and are ready to be installed on the engine.

Torque values are listed in each step. If a torque value is **not** specified, use the chart listed in the Specifications, Group 18, to determine the correct torque value.

Many of the gaskets and o-rings are manufactured from a material designed to absorb oil. These gaskets will enlarge and provide a tight seal after coming in contact with oil. Use **ONLY** a recommended contact adhesive or a vegetable-based oil to install these parts.

## Engine Disassembly and Assembly - Service Tools

The following special tools are recommended to perform procedures in Group 00. The use of these tools is shown in the appropriate procedure. These tools can be purchased from your local Cummins Authorized Repair Location.

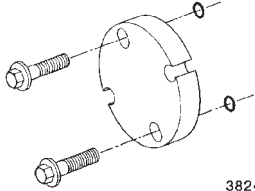
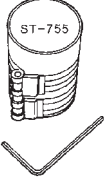
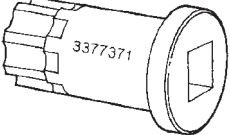
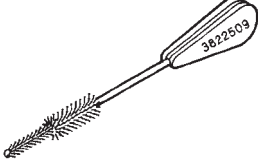
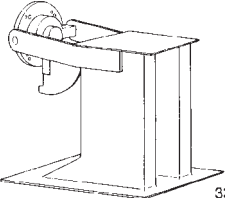
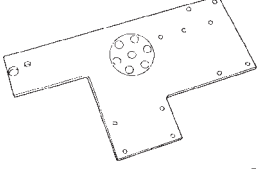
Tool No.	Tool Description	Tool Illustration
3824469	Fuel Pump Drive Gear Puller	 <p style="text-align: right;">3824469</p>
ST-755	Piston Ring Compressor	 <p style="text-align: right;">st-755</p>
3377371	Engine Barring Tool	 <p style="text-align: right;">3377371</p>
3822509	Injector Bore Brush	 <p style="text-align: right;">3822509</p>
3375193 3375194	Engine Rebuild Stand	 <p style="text-align: right;">3375193</p>
3376975	Engine Rebuild Stand Adapter	 <p style="text-align: right;">3376975</p>

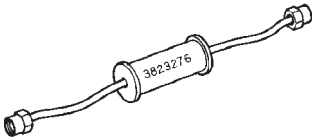
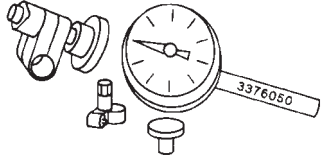
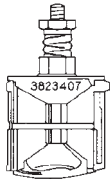
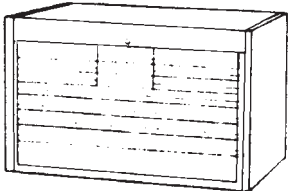
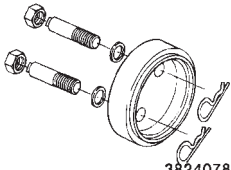
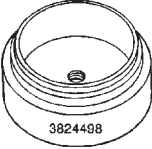

Tool No.	Tool Description	Tool Illustration
3823276	<b>Flexible Injector Puller</b>	
3376050	<b>Dial Indicator &amp; Sleeve Assembly</b> Use with Part No. ST-1325 Dial Gauge Attachment to measure flywheel and flywheel housing runout.	
3823407	<b>Ridge Reamer</b>	
3376593	<b>Mechanic's Tool Kit</b>	
3824078	<b>Wear Sleeve Installation Tool</b> Used to install the rear crankshaft lubricating oil seal wear sleeve.	
3824498	<b>Oil Seal Installation Tool</b> Used to install the front crankshaft lubricating oil seal in the front cover to a specified depth.	

## Engine Disassembly Check List

The following is a checklist of recommended measurement to be made during disassembly to aid in determining the reuse of certain parts.

1. Injection pump drive gear backlash	0.076 - 0.330 mm [0.003 - 0.013 in]
2. Camshaft gear backlash (refer to page 0-26)	0.076 - 0.330 mm [0.003 - 0.013 in]
3. Lube pump gear backlash (refer to page 0-28)	0.076 - 0.330 mm [0.003 - 0.013 in]
4. Lube pump idler gear backlash (refer to page 0-29)	0.076 - 0.330 mm [0.003 - 0.013 in]
5. Balancer (Four Cylinder Only) (Refer to page 0-30)	
• idler gear to crank gear backlash	0.088 - 0.420 mm [0.003 - 0.017 in]
• shaft gear to idler gear backlash	0.088 - 0.420 mm [0.003 - 0.017 in]
• shaft gear to shaft gear backlash	0.153 - 0.355 mm [0.006 - 0.014 in]
6. Camshaft End Play	0.12 - 0.34 mm [0.005 - 0.013 in]
7. Crankshaft End Play	0.102 - 0.432 mm [0.004 - 0.017 in]

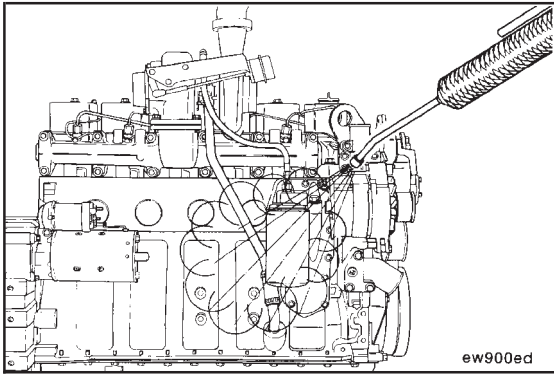

## Engine Disassembly (0-1) Steam Cleaning The Engine (0-2)



**Warning:** When using a steam cleaner, wear protective clothing and safety glasses or a face shield. Hot steam can cause serious personal injury.



**NOTE:** Cover all engine openings and electrical components. This will prevent water damage.

Steam clean the heavy dirt from the exterior of the engine.

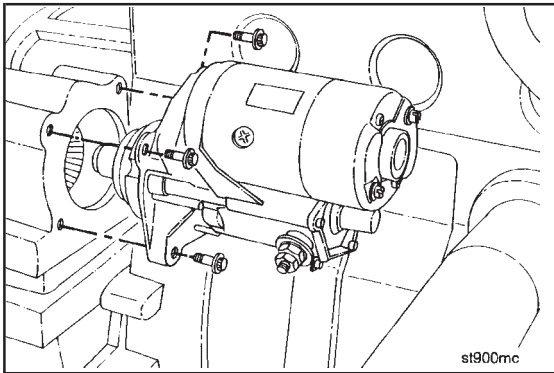

## Starter - Removal (0-3)



10 mm

Remove the starting motor.

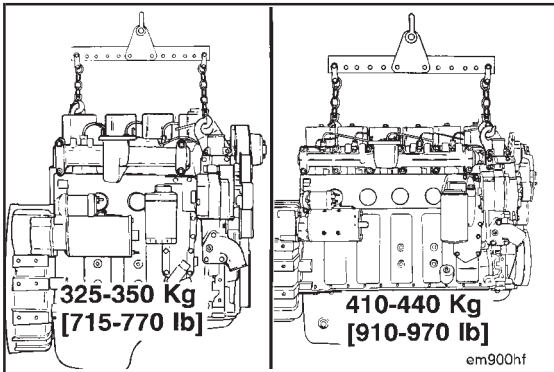

## Engine Weight (0-4)



**3822512 Engine Lifting Fixture**

4B Engine (Wet) Weight: 325-350 Kg [715-770 lb]



6B Engine (Wet) Weight: 410-440 Kg [910-970 lb]

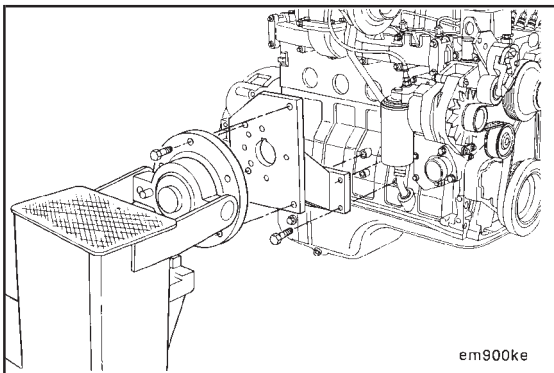

## Rollover Stand - Engine Mounting (0-5)



**18 mm, 3375194 Engine Rebuild Stand, 3376975 Adapter Plate**



Mount the engine on the rebuild stand.

**Torque Value:** 77 N•m [57 ft-lb].

Mounting Hardware:

M12 x 1.75

### Oil - Draining (0-6)

17 mm

Remove the drain plug.

A drain pan with a capacity of 20 litres [5 U.S. gallons] will be adequate.

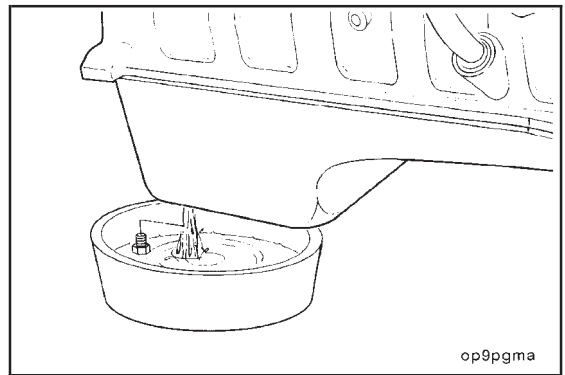

### Lifting Bracket Removal - Rear (0-7)

18 mm

Remove the rear lifting bracket from the cylinder head.

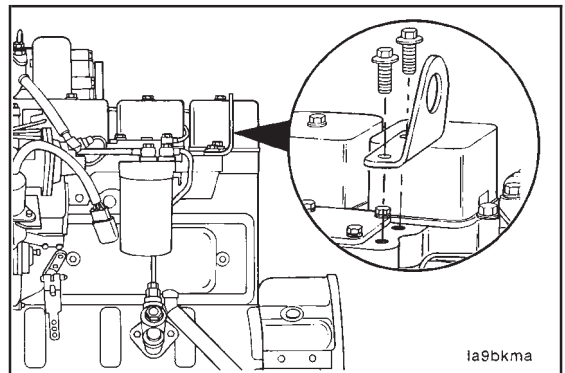

### Drive Belt - Removal (0-8)

Applying excessive force to the tensioner in the opposite direction of wind-up or after the tensioner has been wound-up to the positive stop can cause the tensioner arm to break.

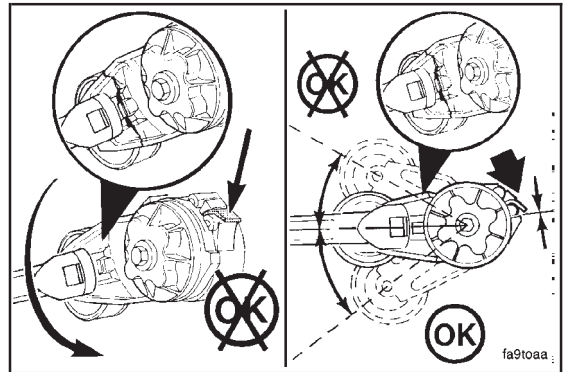

**Caution:** Keep hands out of the path of the spring-loaded tensioner.

1/2 inch or 3/8 inch Square Drive

Release the tension and remove the drive belt.

Service Tip: Loosen the vibration damper/crankshaft and fan hub pulley capscrews before removing the drive belt.

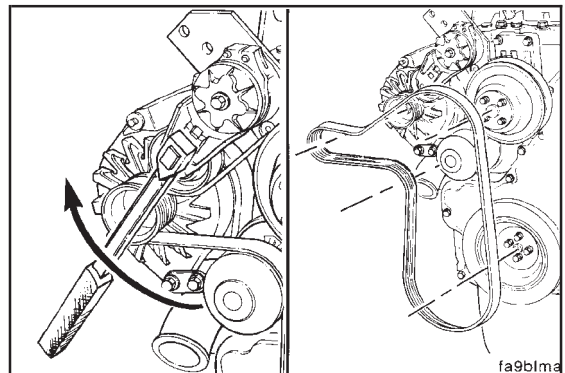

Fan Pulley - Removal (0-9)  
Page 0-10

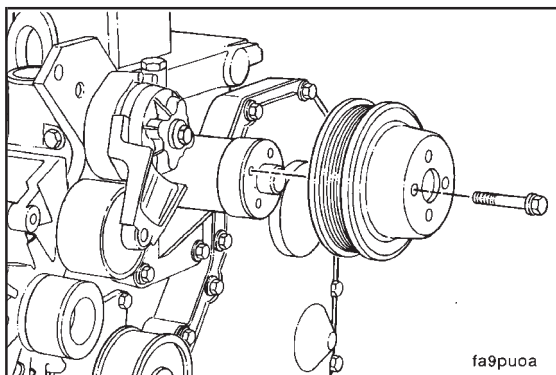

13 mm

Remove the fan pulley and capscrews.



Vibration Damper/Crankshaft Pulley -  
Removal (0-10)

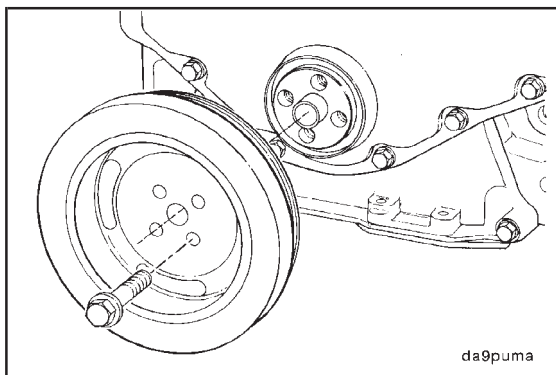

15 mm

Remove the vibration damper or crankshaft pulley and capscrews.



**NOTE:** Refer to Component Section 1 for the vibration damper inspection procedure.



Belt Tensioner - Removal (0-11)

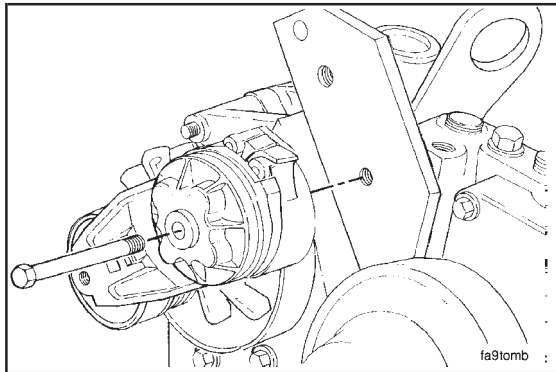

15 mm

Remove the belt tensioner from the bracket.



**NOTE:** Refer to Component Section 8 for the belt tensioner inspection procedure..



5 mm Allen

Remove the tensioner bracket.

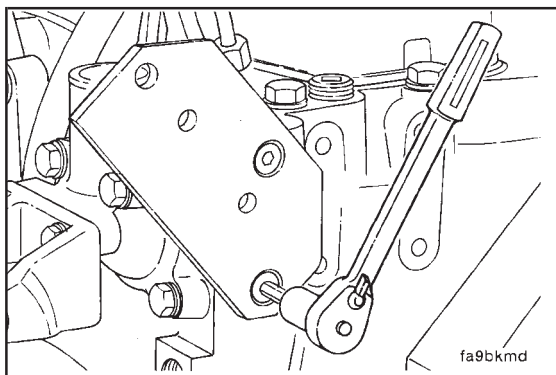

### Fan Hub - Removal (0-12)

10 mm

Remove the fan hub.

**NOTE:** Refer to Component Section 8 for inspection of the fan hub.

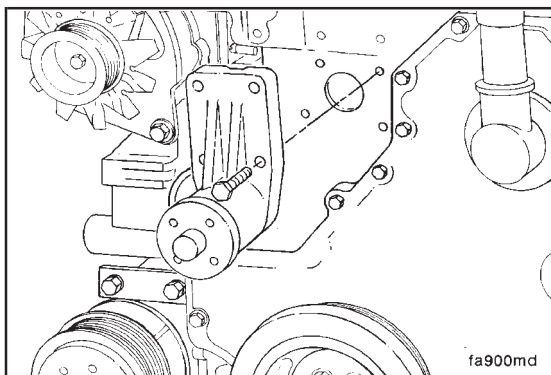

### Alternator - Removal (0-13)

13 mm

Remove the alternator link.

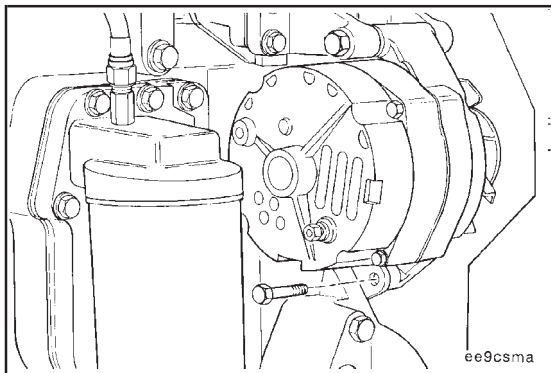

16 mm

Remove the alternator mounting capscrew and alternator.

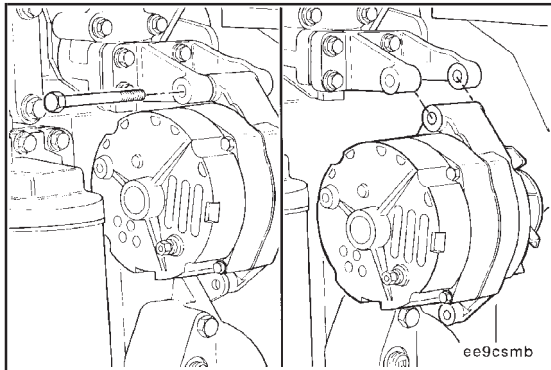

13 mm

Remove the alternator bracket.

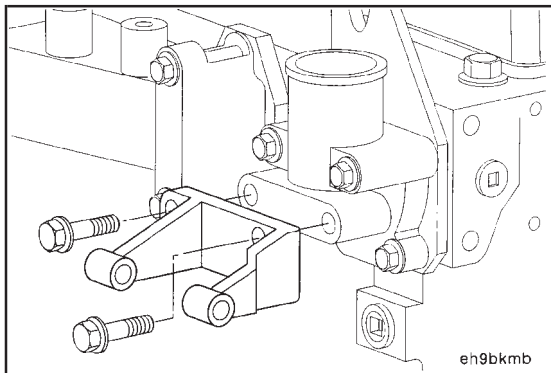

Thermostat - Removal (0-14)  
Page 0-12

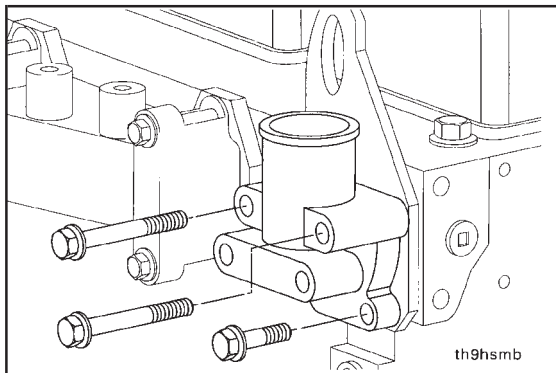

10 mm

Remove the capscrews from the thermostat housing.

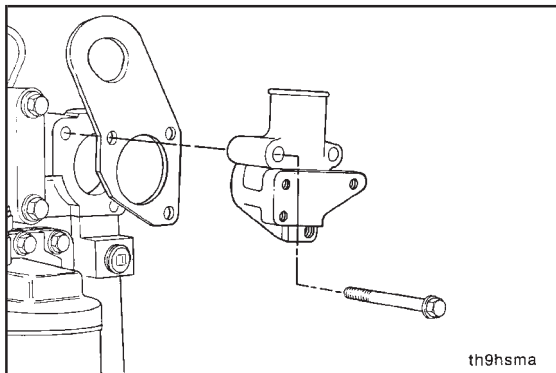

Remove the thermostat housing, gasket, thermostat and lifting bracket.



**NOTE:** Refer to Component Section 8 for inspection of the thermostat.

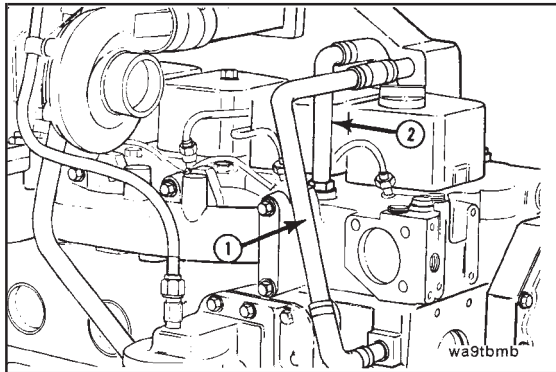

Screwdriver

If so equipped, remove the aftercooler supply tube (1) and the coolant return tube (2).

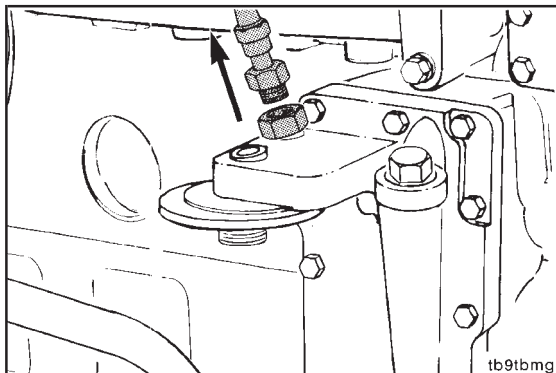

Turbocharger - Removal (0-15)

16 mm and 19 mm

Remove the turbocharger oil supply line from the turbocharger and oil filter head.



**8 mm, Screwdriver**

Remove the air crossover tube.

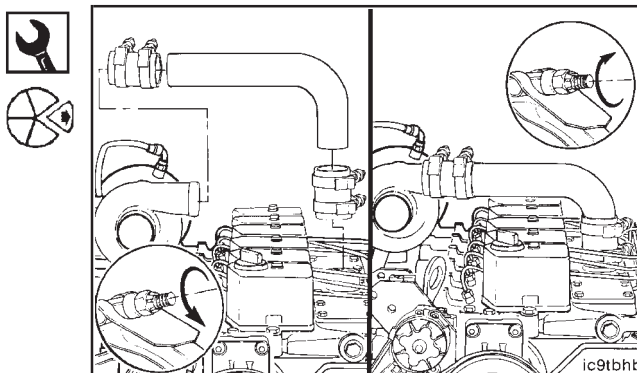

On Automotive engines, loosen the V-Band clamp and hose clamp and remove the charge air cooler inlet tube.

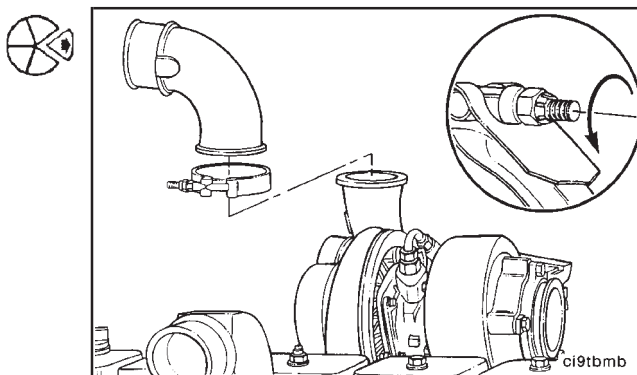

**10 mm**

Disconnect the drain tube from the bottom of the turbocharger.

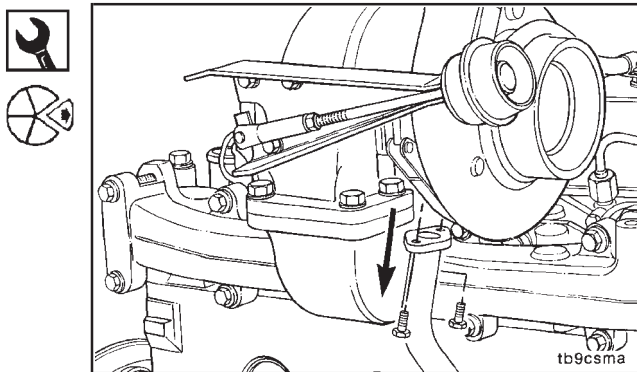

**Screwdriver**

Remove the turbocharger drain line from the drain tube in the cylinder block.

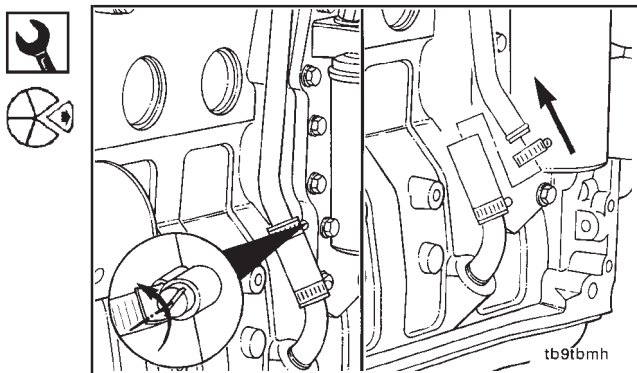



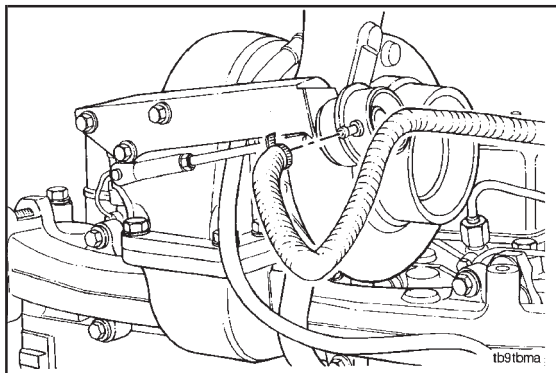

On engines equipped with wastegated turbochargers, remove the wastegate intake air hose.

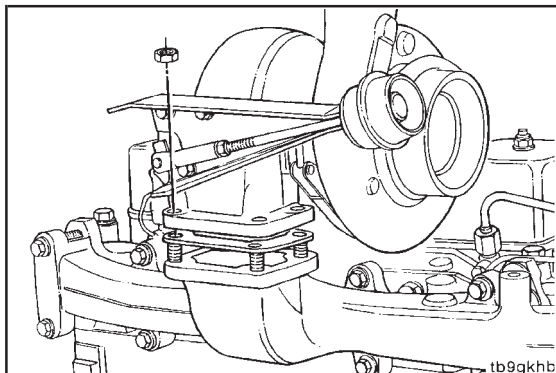

15 mm

Remove the turbocharger mounting nuts, turbocharger and gasket.



**NOTE:** Inspection of the turbocharger is described in Component Section 10.

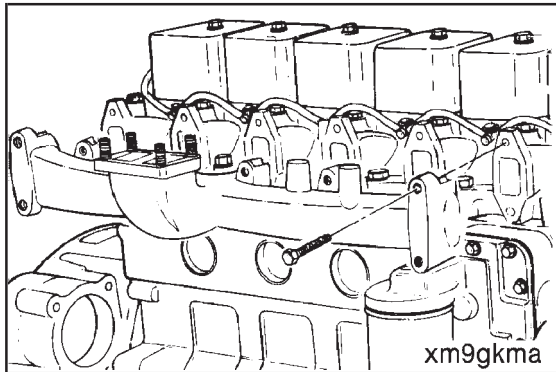

### Exhaust Manifold - Removal (0-16)

13 mm

Remove the capscrews, exhaust manifold and gaskets.



**NOTE:** Inspection of the exhaust manifold is described in Component Section 11.

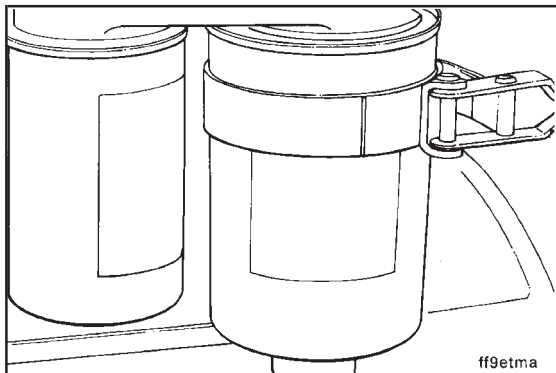

### Fuel Filter - Removal (0-17)

75-80 mm, 90-95 mm Strap Wrenches

Remove the fuel filter(s).



### Fuel Filter Head - Removal (0-18)

24 mm

If equipped with a dual filter head, remove the nut, dual filter head and o-ring.

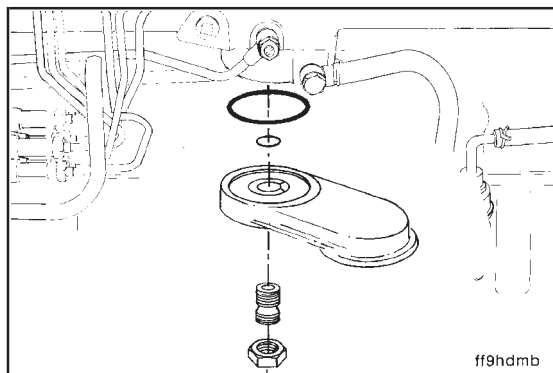

### Screwdriver

Remove fuel filter adapter and o-ring.

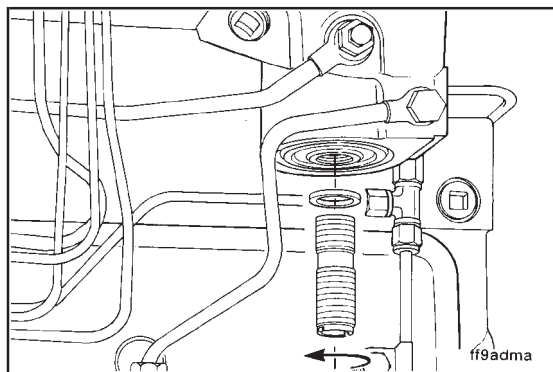

### KSB (Remote Mounted) - Removal (0-19)

Remove the KSB wiring harness.

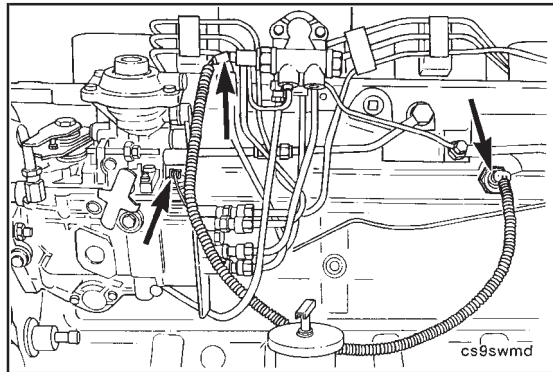

10 mm

Remove the banjo screw securing the fuel transfer tube to the low pressure fuel supply banjo screw.

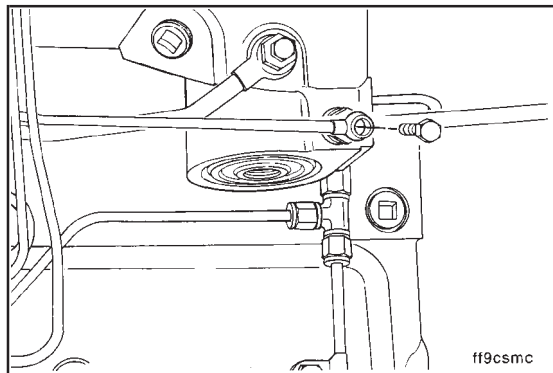

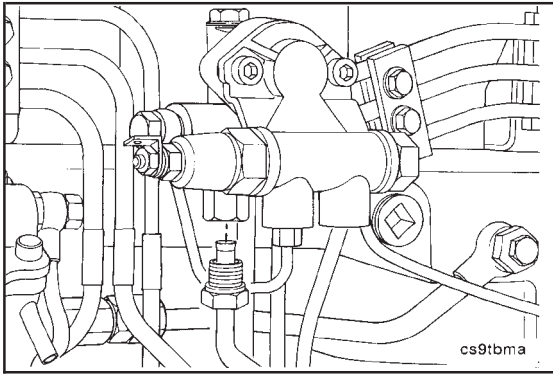

11 mm and 15 mm

Remove the flex hose from the KSB assembly. It is not necessary to remove the flex hose from the injection pump.

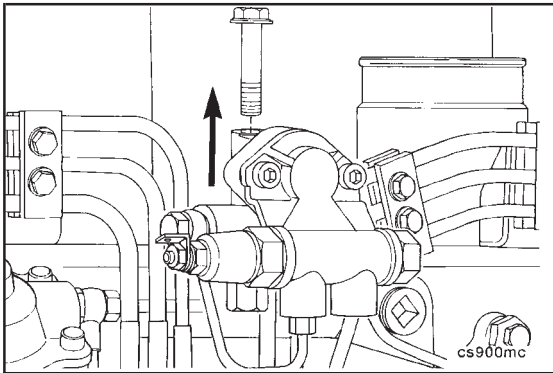

10 mm

Remove the KSB assembly from the intake manifold cover.

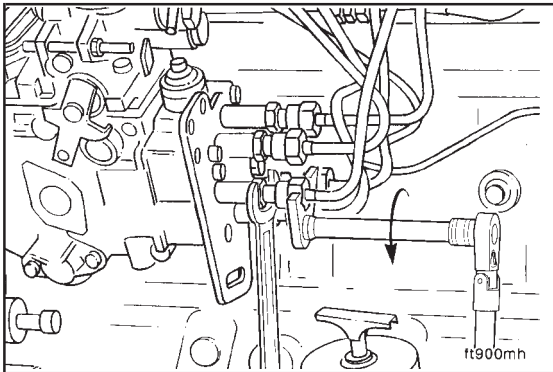

### Fuel Lines - Removal (0-20)

#### High Pressure Fuel Line - Removal (0-21)

14 mm, 17 mm Crowsfoot Wrench, 19 mm Crowsfoot Wrench



**Caution:** Hold the fuel pump delivery valves securely when loosening the high pressure lines on the rotary pumps.



Remove the high pressure line fittings from the injection pump.

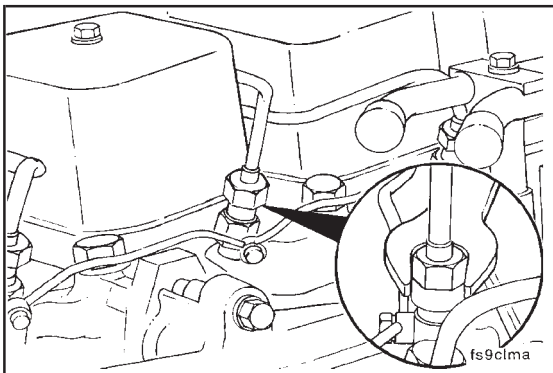

17 mm, 19 mm

Remove the high pressure lines from the injectors.



**NOTE:** Refer to Component Section 6 for fuel line inspection.



**10 mm**

Remove the manifold cover capscrews that secure the high pressure line support brackets.

Remove the high pressure lines as an assembly.

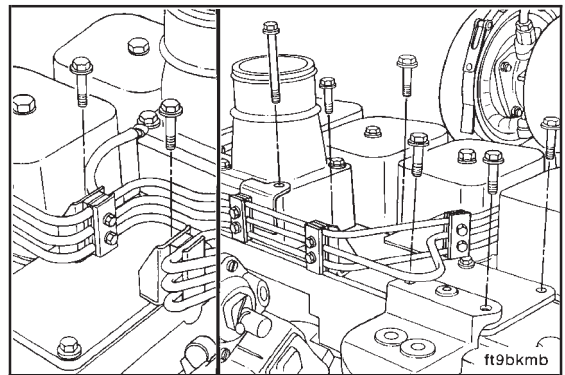

Cap or cover the injector openings.

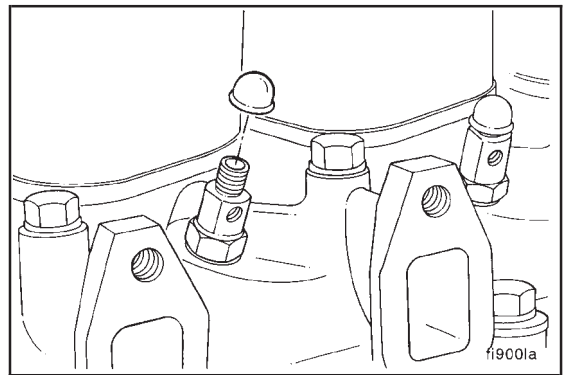

**12 mm and 13 mm**

If so equipped, remove the air/fuel control tube and turbo-charger wastegate line.

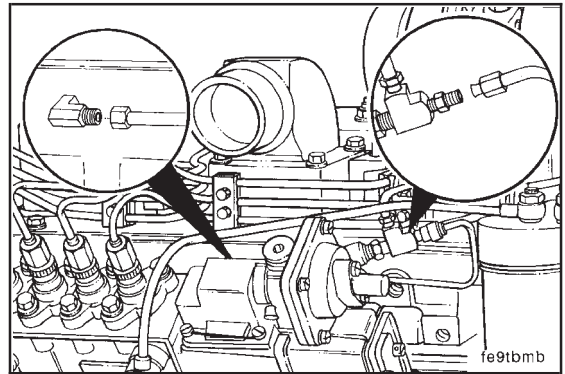

**Fuel Drain Manifold - Removal (0-22)**

**10 mm**

Remove the fuel drain manifold banjo fittings and sealing washers from the injectors.

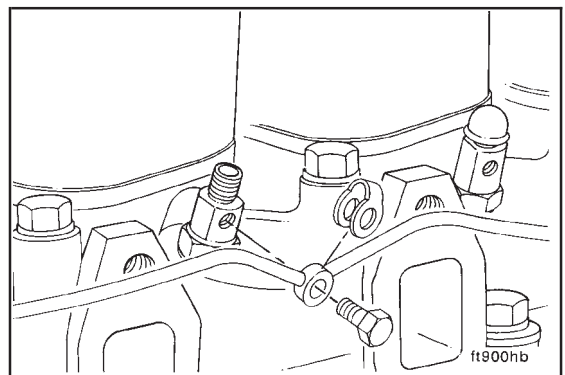

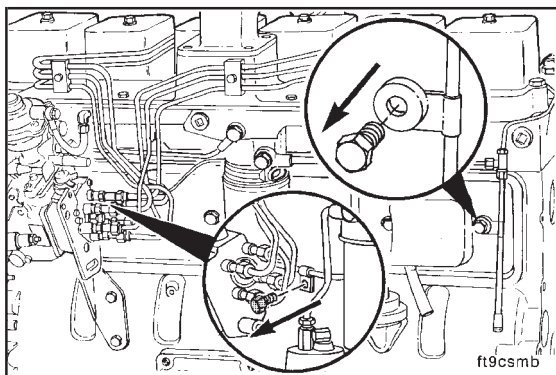

17 mm and 10 mm

**Rotary Fuel Pump**



Remove the fuel drain manifold support brackets and banjo fitting.

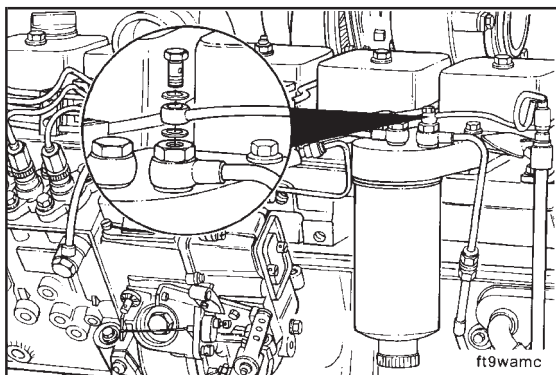

10 mm, 12 mm

**In Line Fuel Pump**



Remove the banjo capscrews and sealing washers at the filter head.

Remove the fuel line support bracket capscrew from the intake manifold.

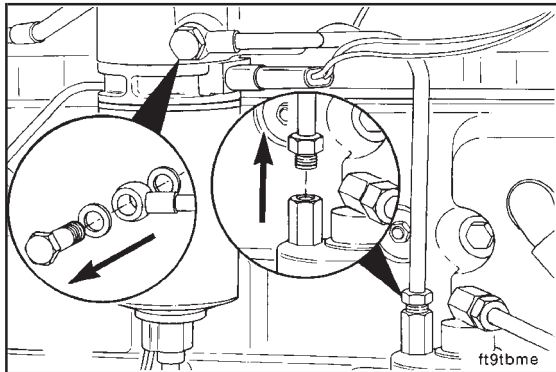

**Low Pressure Fuel Lines - Removal (0-23)**

17 mm

Disconnect the two banjo fittings at the filter head.

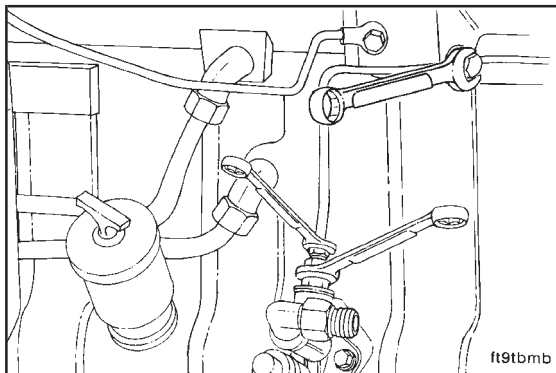

14 mm and 17 mm

**Caution:** Be sure the fuel transfer pump connection is held securely when loosening the fuel line.



Loosen the nut and remove the fuel line from the lift pump.



14 mm and 17 mm

**Caution:** Be sure the fuel pump connection is held securely when loosening the supply line.

Remove the injection pump supply line.

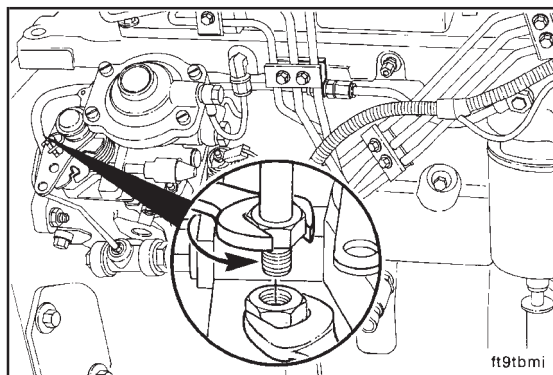

### Dipstick - Removal (0-24)

If equipped with a dipstick tube extension, remove the dipstick and extension.

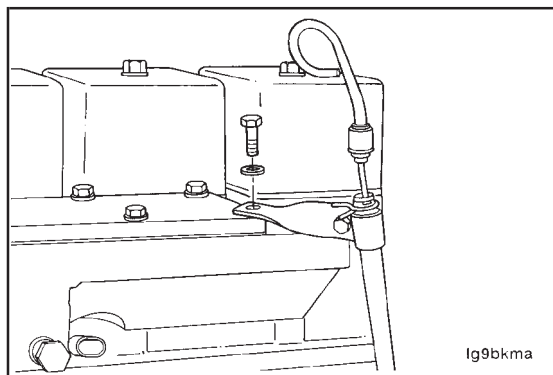

### Manifold Cover - Removal (0-25)

10 mm

Remove the manifold cover, gasket and grid heater if equipped.

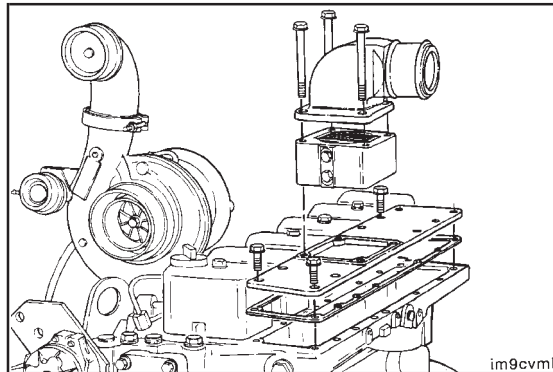

### Aftercooler - Removal (0-26)

10 mm

If equipped, remove the aftercooler housing.

**NOTE:** Refer to Component Section 10 for the aftercooler inspection procedure.

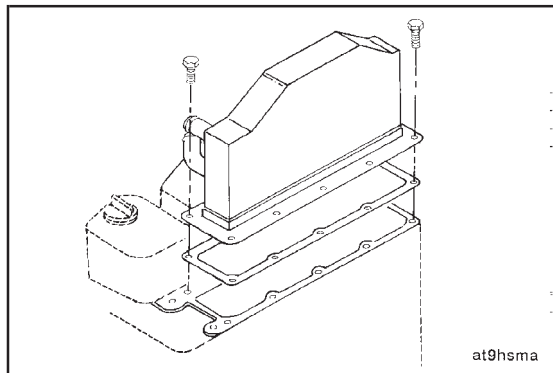

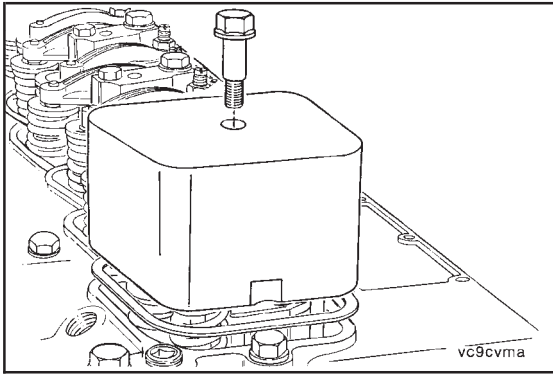

### Valve Covers - Removal (0-27)

15 mm

Remove the special capscrews, o-ring seals, valve covers and gaskets.

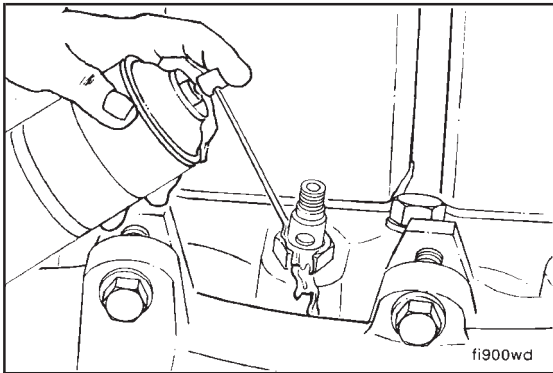

### Injector Nozzles - Removal (0-28)

Rust Penetrating Solvent

**Caution:** When rust has formed on the hold down nut, the injector can turn in the bore when the nut is loosened. This will cause severe damage to the head by the injector locating ball cutting a groove in the bore.

Soak the hold down nut with a rust penetrating solvent for a minimum of 3 minutes.

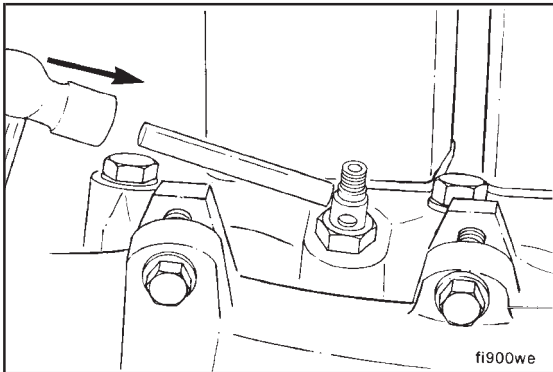

Brass Drift Pin, Hammer

**Caution:** Excessive force will damage the injector.

Tap the injector body with the hammer and drift pin to loosen any rust.

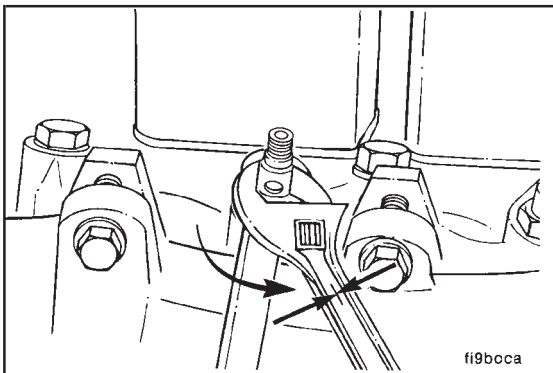

24 mm Box Wrench, Adjustable Wrench

Hold the injector body with an adjustable wrench while you loosen the hold down nut with a 24mm box wrench.

**Injector Puller 3823276**

Remove the injectors. If the injector is extremely difficult to remove, remove the injector o-ring and fill the bore around the injector with a penetrating solvent. Attach the injector puller and pull the injector out as far as possible, then use the injector puller slide hammer to tap against the puller nut and drive the injector into the bore. Repeating this procedure will allow the solvent to penetrate to the injector tip and loosen the carbon deposits on the tip.

Refer to Component Section 6 for the injector test procedures.

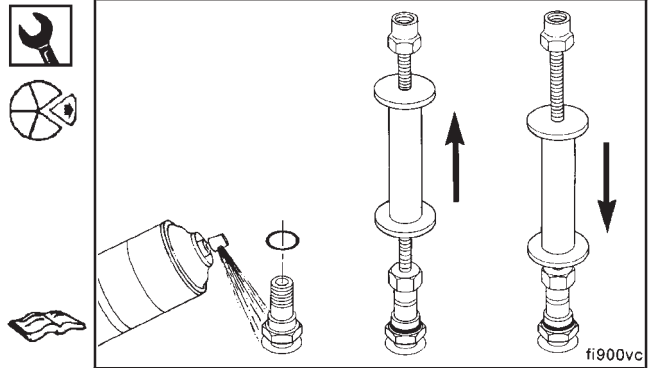

**Rocker Levers - Removal (0-29)**

**14 mm, Screwdriver**

Loosen the nuts on the rocker lever adjusting screws and loosen screws until they stop.

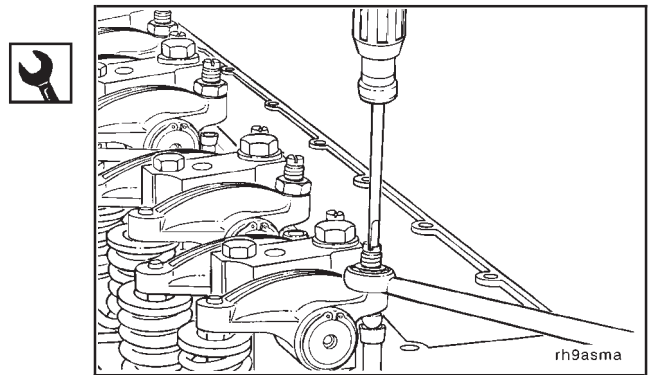

**13 mm, 18 mm**

Remove the pedestal/head bolts from the rocker shaft pedestals and lift off the pedestal and rocker lever assemblies.

**NOTE:** Refer to Component Section 3 for disassembly of the rocker lever assemblies.

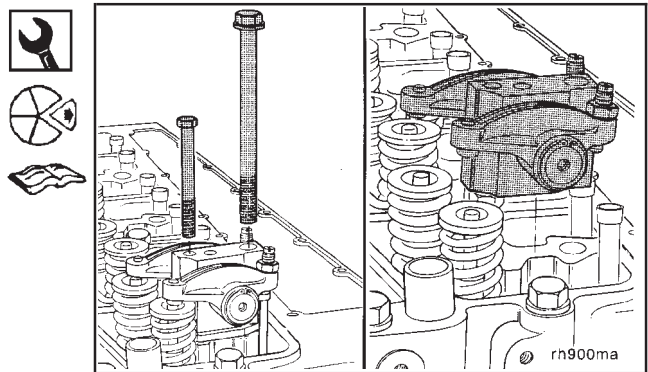

**Push Rods - Removal (0-30)**

Remove the push rods.

**NOTE:** Refer to Component Section 4 for the push rod inspection procedure.

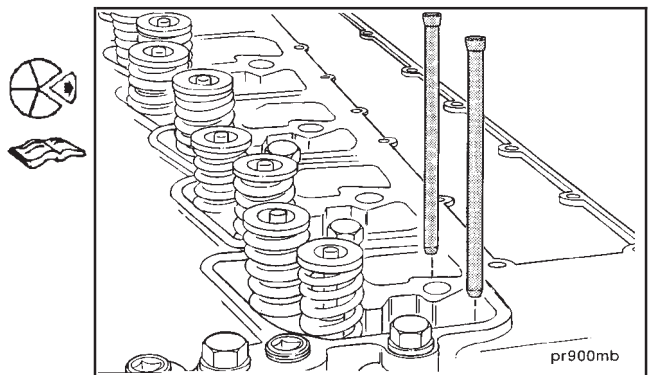



Cylinder Head - Removal (0-31)  
Page 0-22

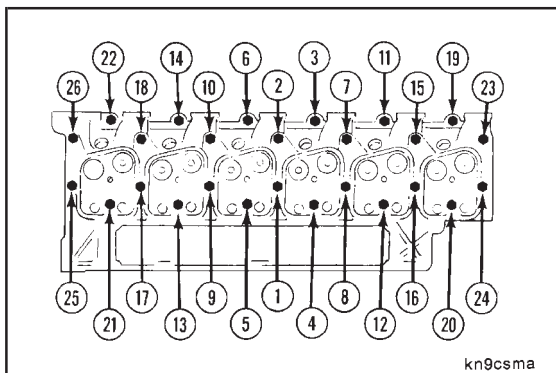

**Cylinder Head - Removal (0-31)**

18 mm

Remove the remaining cylinder head capscrews in the sequence shown.

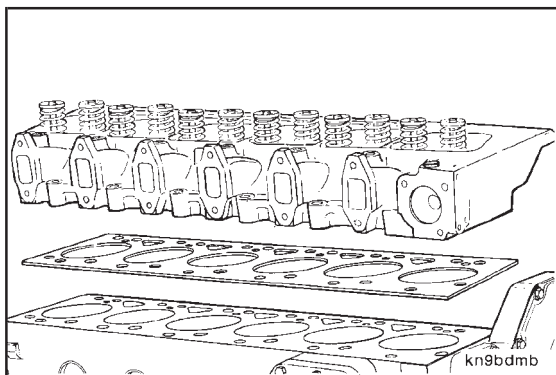

Remove the cylinder head and gasket from the block.

**Cylinder Head Weight:**

- 4 Cylinder - 36 Kg [80 lb]
- 6 Cylinder - 52 Kg [114 lb]



**NOTE:** Disassembly of the head is described in Component Section 2.

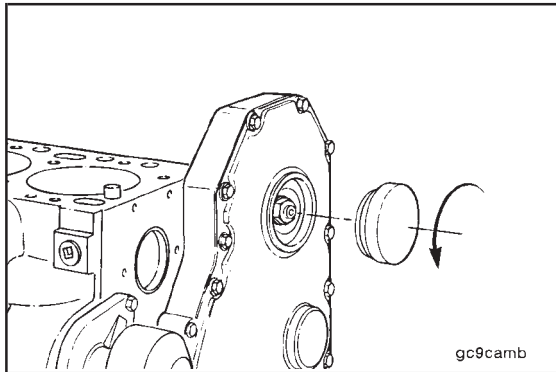

**Front Cover - Removal (0-32)**

90-100 mm Strap Wrench

Remove the front cover access cap.



**Service Tip:** A strap type filter wrench can be used to loosen access caps that have been excessively tightened.

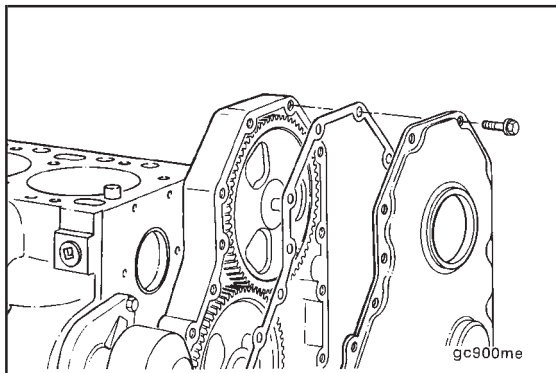

10 mm

Remove the front cover and gasket.



**Hammer, Punch**

Support the seal area in the front cover and drive out the seal.

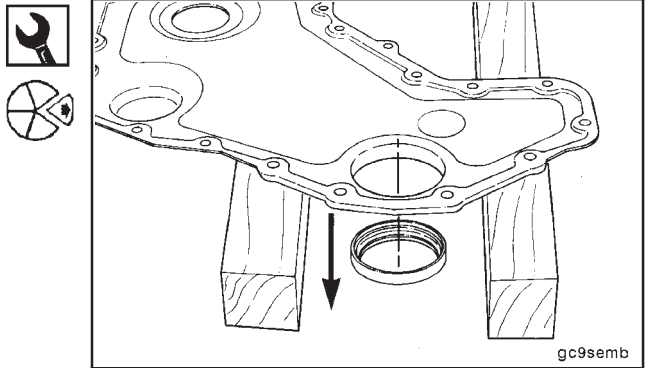

**Water Pump - Removal (0-33)**

13 mm

Remove the water pump and o-ring.

Refer to Component Section 8 for the water pump inspection.

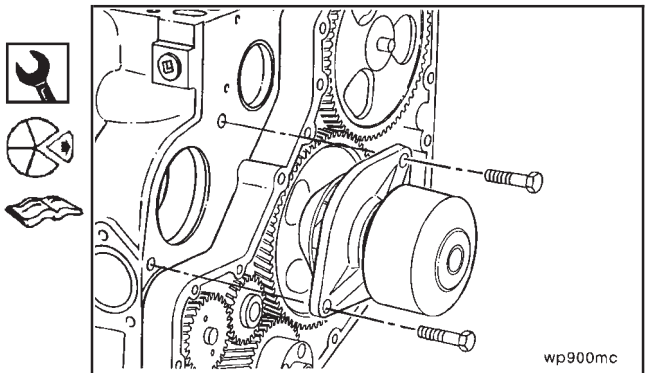

**Flywheel - Removal (0-34)**

18 mm

Lock the crankshaft and remove the capscrews, washers and flywheel.

**NOTE:** Refer to Component Section 16 for flywheel inspection.

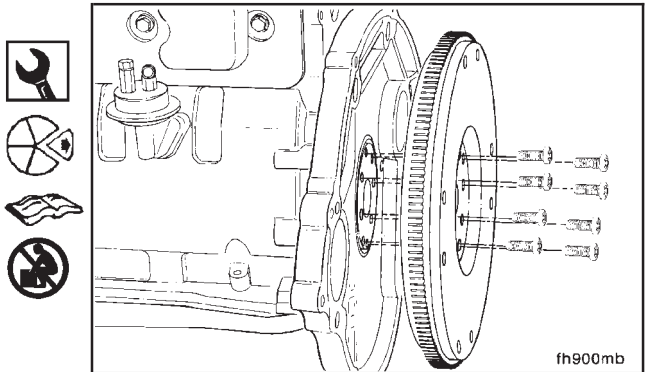

**Flywheel Housing - Removal (0-35)**

15 mm

Remove the flywheel housing.

**NOTE:** Refer to Component Section 16 for the flywheel housing inspection procedure.

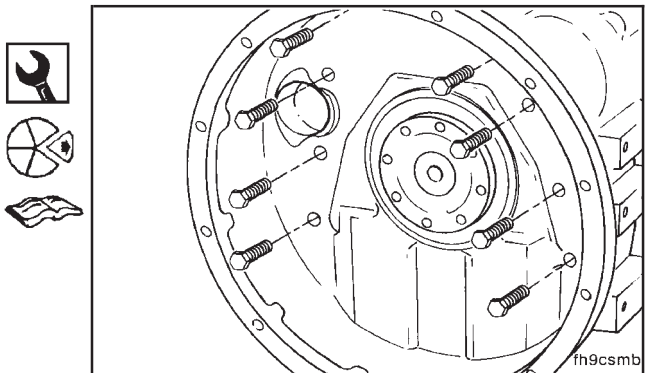

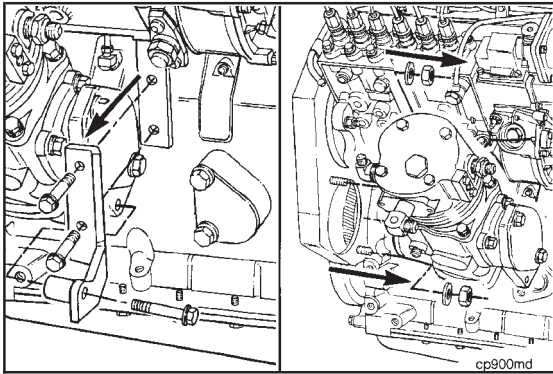

### Accessories - Removal (0-36)

10 mm, 14 mm, 18 mm

If equipped, remove all additional gear driven accessories, (air compressor, hydraulic pump, etc.).



**NOTE:** Refer to the Manufacturer's Service Information for repair instructions.

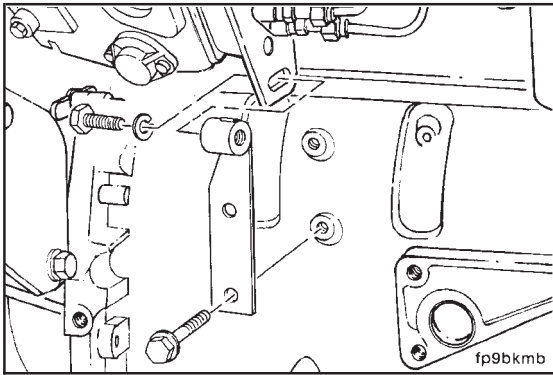

### Injection Pump - Removal (Rotary Type Pumps) (0-37)

13 mm

**Caution:** A diesel engine cannot tolerate dirt or water in the fuel system. A tiny piece of dirt or a few drops of water in the injection system can cause damage to the system.



Clean all external surfaces of the injection pump, including all line connections and fittings that are to be disconnected. Clean the area around the injection pump gear cover to prevent dirt from entering the crankcase.



Remove the injection pump support bracket and capscrews.

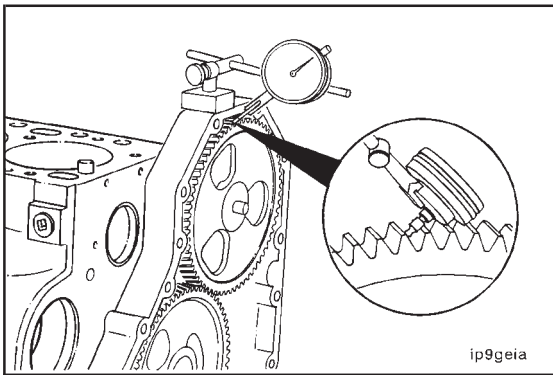

### Gear Lash - Check (0-38)

Position an indicator on the tooth of the injection pump drive gear.

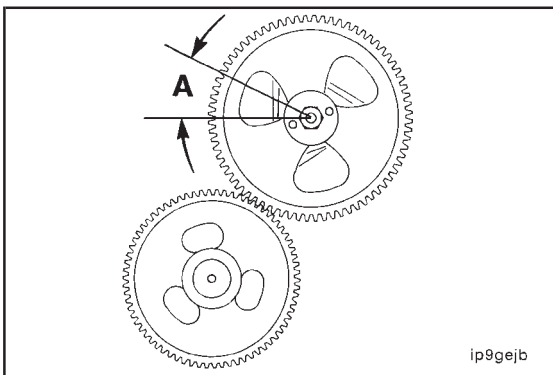

Note the total indicator travel as injection pump drive gear backlash. Mark the pump drive gear and camshaft gear for further analysis if the backlash exceeds the limits.

Injection Pump Drive Gear Backlash Limit (A)		
mm		in
0.076	MIN	0.003
0.330	MAX	0.013

**NOTE:** Prevent movement of adjoining gear when checking backlash or the reading will be the total of both gears.

**Locking the Pump (0-39)**

Locate TDC for Cylinder Number 1 by slowly barring the engine while pushing in on TDC pin.

**BE SURE TO DISENGAGE THE PIN AFTER LOCATING TDC.**

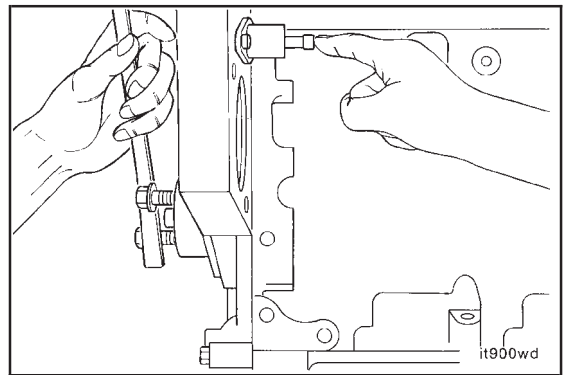

**14 mm**

Loosen the CAV injection pump lockscrew, position the special washer with the small opening showing, then tighten the lockscrew against the pump drive shaft.

**Torque Value:** 7 N•m [5 ft-lb]

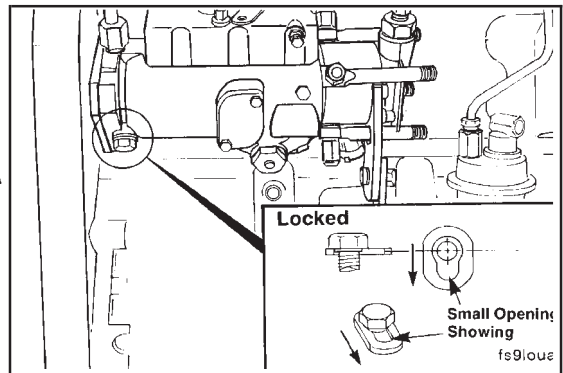

**3/8 inch**

Loosen the lockscrew for the Stanadyne DB4 fuel injection pump. Position the special washer behind the lock screen head. Tighten the lockscrew.

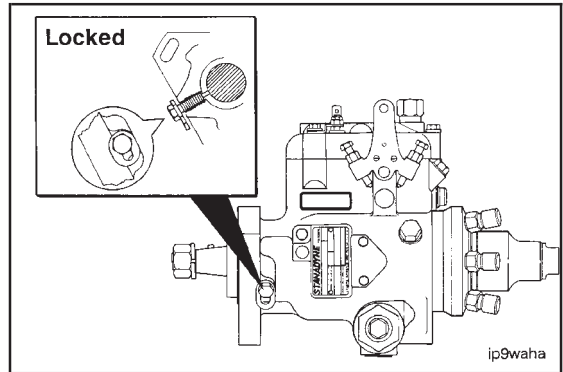

**10 mm**

The special washer on the Bosch injection pump must be removed so the lockscrew can be tightened against the drive shaft.

**NOTE:** Before removing the Bosch pump, the pump must be locked with the No. 1 Cylinder in TDC position.

**Torque Value:** 30 N•m [22 ft-lb].

Wire the special washer to the Bosch pump.

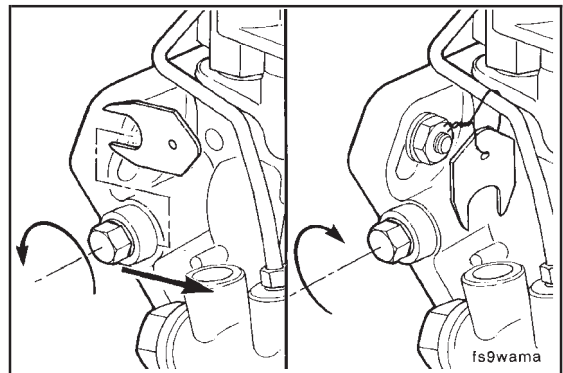

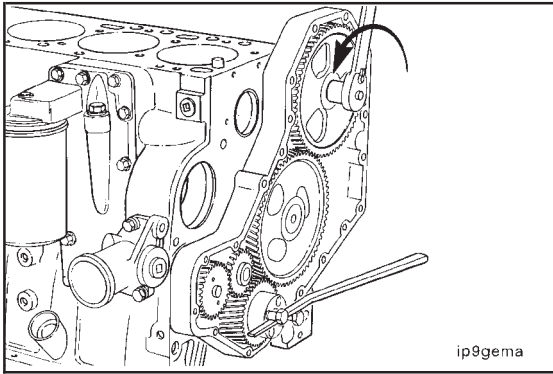

**Drive Gear - Removal (0-40)**

22 mm



**Caution:** Hold the crankshaft to prevent the rotation of the locked injection pump.



Remove the mounting nut and lock washer from the pump drive shaft.

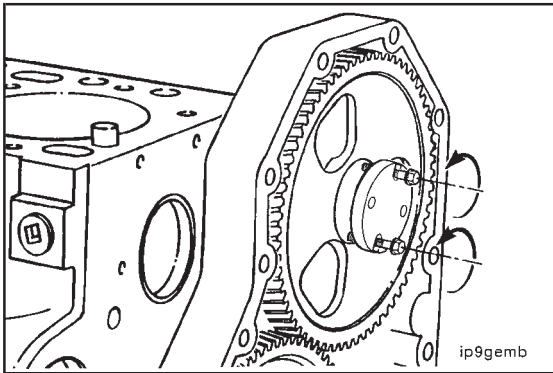

**75 mm T-Bar Puller or Fuel Pump Drive Gear Puller  
Part No. 3824469**



Pull the pump drive gear loose from the drive shaft.

The puller hole threads are M8 X 1.25.

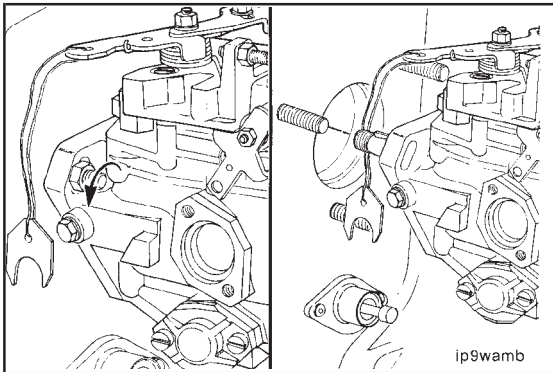

13 mm

Remove the three mounting nuts. Remove the injection pump.



**NOTE:** Refer to the applicable Manufacturer's Service Instructions for injection pump testing/repair. Minor repairs are described in Component Section 5.

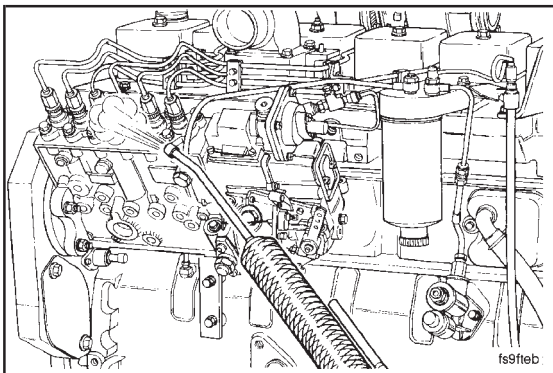

**Injection Pump - Removal (In-Line)  
(0-41)**

**Caution:** A diesel engine cannot tolerate dirt or water in the fuel system. A tiny piece of dirt or a few drops of water in the injection system can cause damage to the system.



Clean all external surfaces of the injection pump, including all line connections and fittings that are to be disconnected. Clean the area around the injection pump gear cover to prevent dirt from entering the crankcase.

Preparatory Steps:

- Remove all fuel lines.
- Remove the control linkage.
- Remove the fuel shutoff solenoid.
- Remove the fuel filter.
- Remove the fuel pump support bracket.

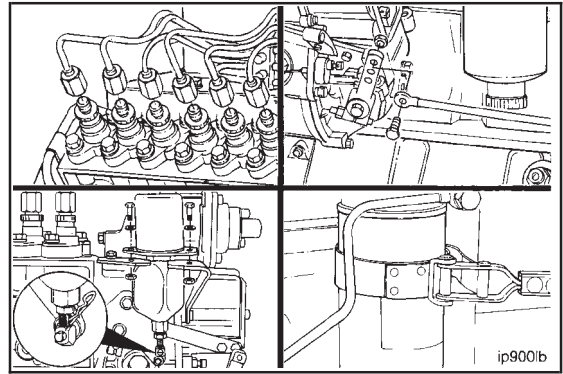

**14 and 15 mm**

Disconnect the lubricating oil supply line from the fuel pump.

Disconnect the lubricating oil supply line from the engine block.

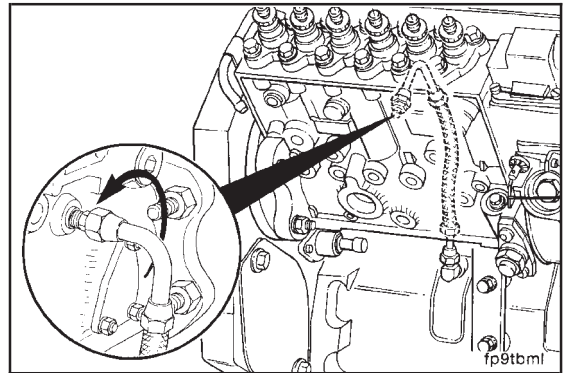

**3377371 Barring Tool**

Make sure the crankshaft has No. 1 cylinder at Top Dead Center (TDC).

Rotate the engine until the timing pin engages.

Be sure to disengage the pin after locating TDC.

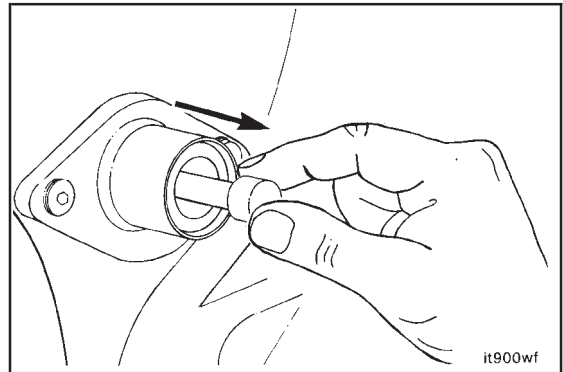

**22 mm**

Remove the nut and washer from the fuel pump shaft.

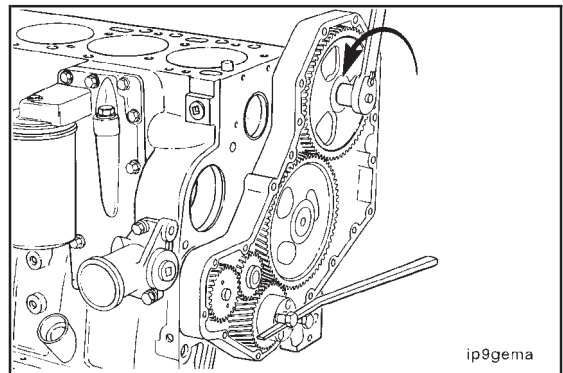

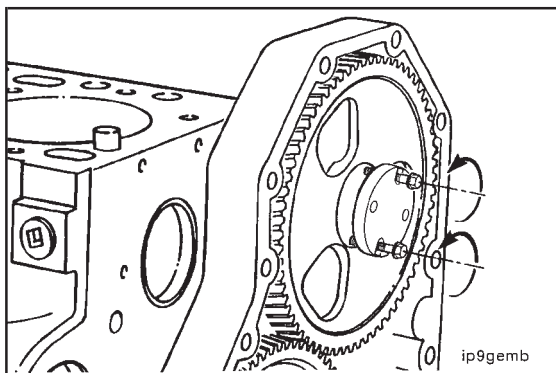

Two M8 x 1.25 Capscrews, 75 mm T-Bar, or Fuel Pump Drive Gear Puller 3824469



Pull the pump gear from the drive shaft.

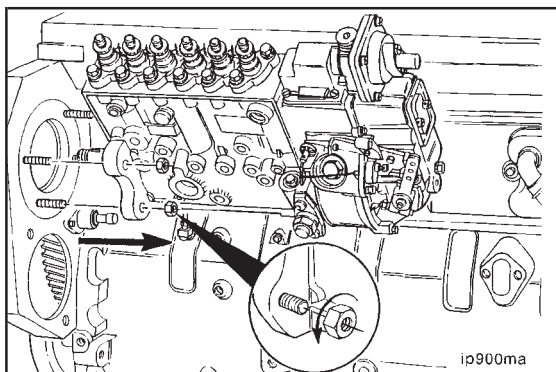

15 mm

Remove the four mounting nuts and injection pump.

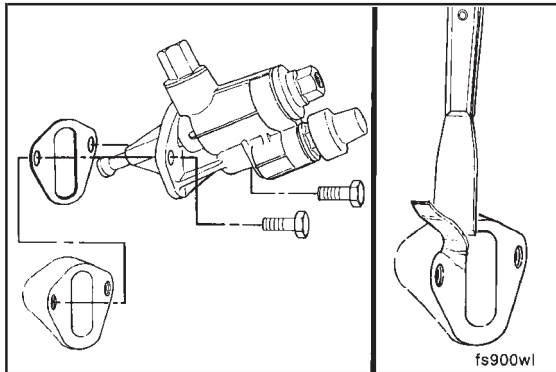

### Fuel Transfer Pump - Removal (0-44)

10 mm

Remove the fuel transfer pump, spacer, and gaskets.



**NOTE:** Refer to Component Section 6 for fuel transfer pump test procedures.

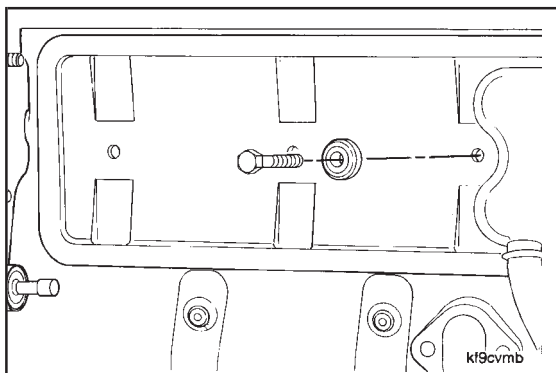

### Tappet Cover - Removal (0-45)

10 mm

Remove the tappet cover and gasket.



### Side Oil Fill - Removal (0-46)

18 mm

If present, remove the capscrews, side oil fill assembly and rectangular ring seal. Some engines may have an air compressor oil drain connection attached at this location. Remove the connection and rectangular ring seal.

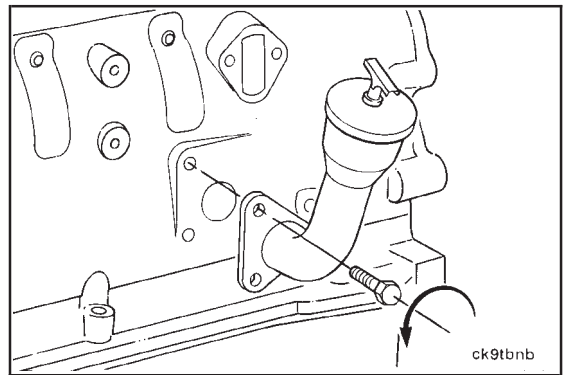

### Oil Cooler - Removal (0-47)

90-95 mm [3-1/2 to 3 7/8 in] Filter Wrench

Remove the oil filter.

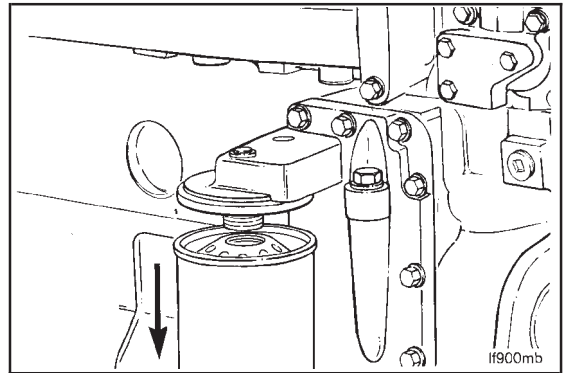

10 mm

Remove all the capscrews, oil cooler cover, cover gasket, oil cooler and cooler gasket.

**NOTE:** Refer to Component Section 7 for inspection procedures.

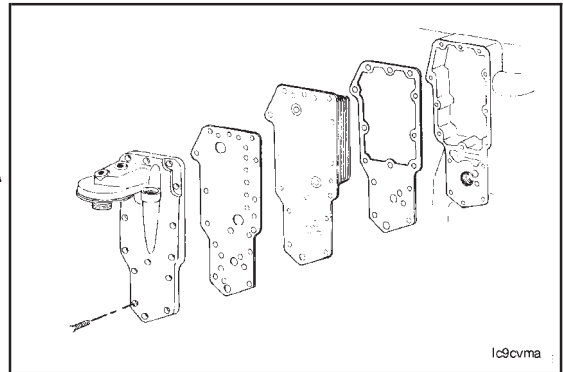

### Water Inlet Connection - Removal (0-48)

13 mm

Remove the water inlet connection and rectangular ring seal.

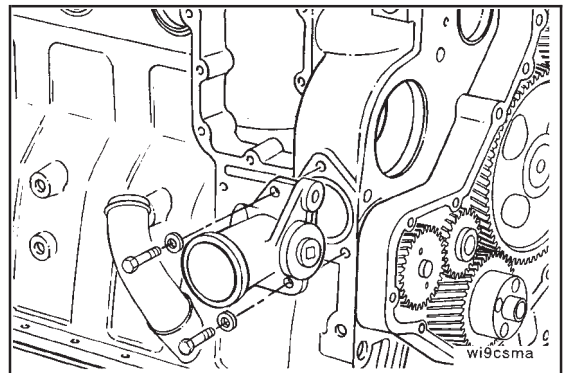



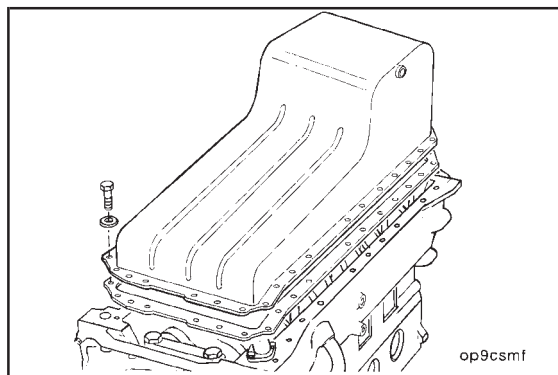

10 mm



Rotate the engine on the stand and remove the oil pan and gasket.

### Suction Tube - Removal (0-50)

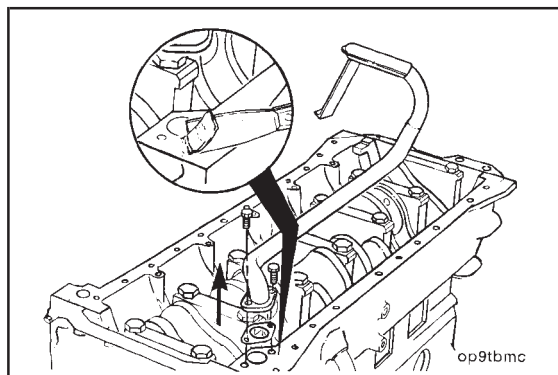

10 mm



Remove the suction tube and gasket.



**NOTE:** Refer to Component Section 7 for the suction tube inspection procedure.

### Rear Seal Housing - Removal (0-51)

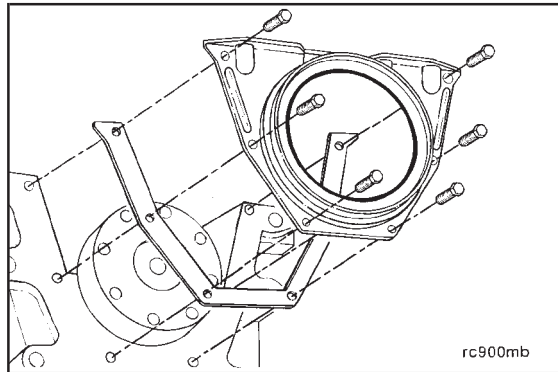

8 mm



Remove the rear seal housing and gasket.

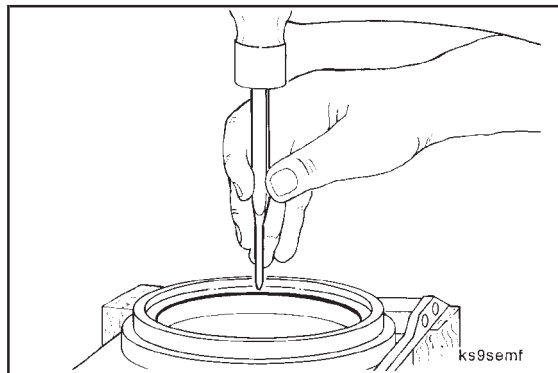

Support the seal area of the rear seal housing and press/ drive out the seal.

## Camshaft - Removal (0-52)

### Measuring Gear Lash (0-53)

Position an indicator on a tooth of the camshaft gear.

**NOTE:** The cylinder block position shown in the illustration is for clarity. The cylinder block must be positioned with the crankshaft on top to keep the tappets in the bores.

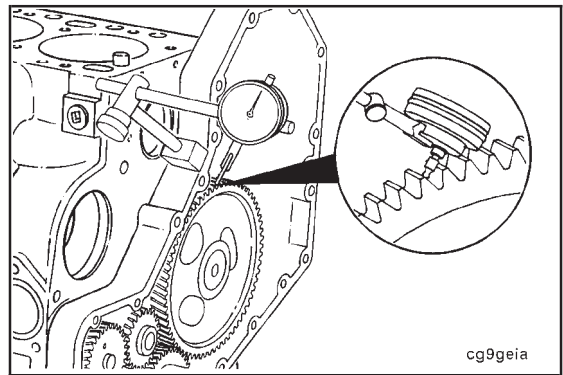

cg9geia

Note the camshaft gear backlash. Mark the camshaft gear and crankshaft gear for further analysis if backlash exceeds limits.

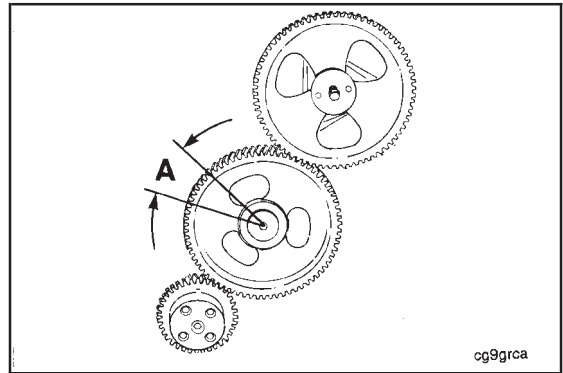

cg9grca

Camshaft Gear Backlash Limit (A)		
mm		in
0.076	MIN	0.003
0.330	MAX	0.013

**NOTE:** Prevent movement of adjoining gear when checking backlash or the reading will be the total of both gears.

Rotate the crankshaft to approximately the TDC position for number one cylinder. Failure to do so will result in the camshaft catching on the connecting rods during camshaft removal.

**NOTE:** The cylinder block is shown in an upright position in the illustration for clarity.

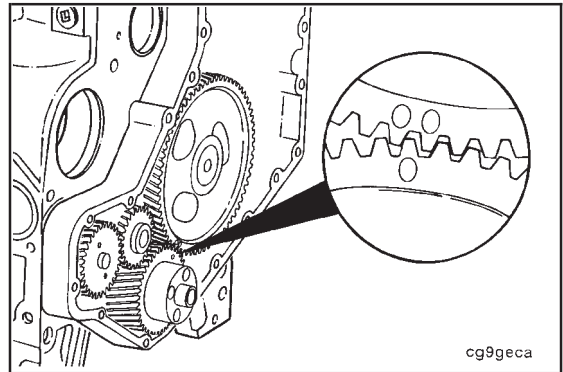

cg9geca

### 13 mm

Remove the thrust plate capscrews.

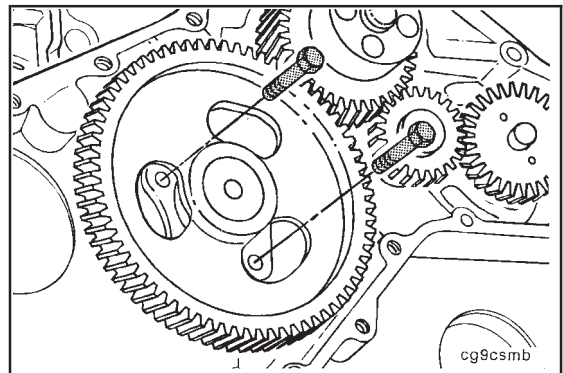

cg9csmb

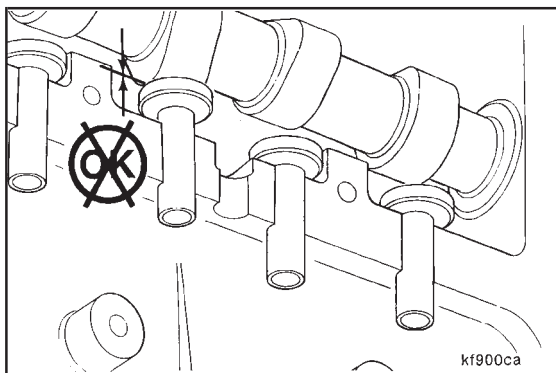

Visually inspect the tappets to make sure they are off the camshaft lobes.

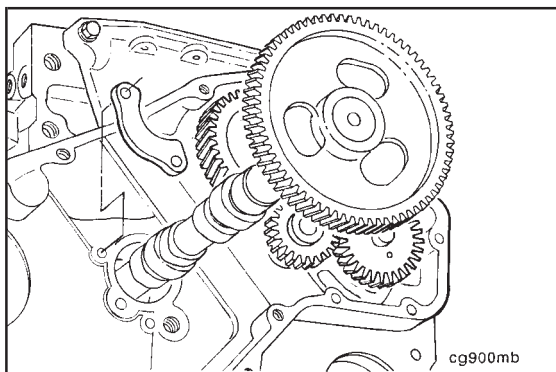

Remove the camshaft and thrust plate from the cylinder block. Take care not to drop the thrust washer.



Service Tip: Rotate the camshaft while pulling outward with a steady pressure during removal.

**NOTE:** Refer to Component Section 1 for disassembly and inspection.

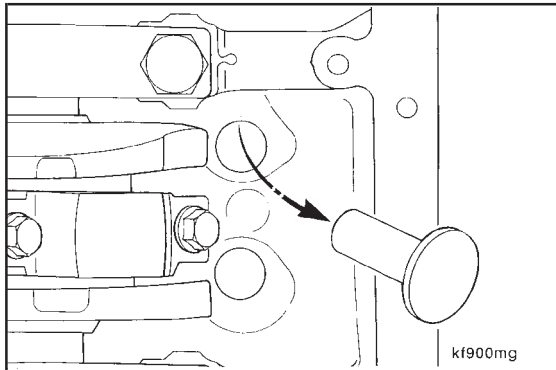

### Valve Tappets - Removal (0-54)



Remove the valve tappets. The engine can be rotated to allow easy access to the tappets.



**NOTE:** Refer to Component Section 4 for inspection procedures.

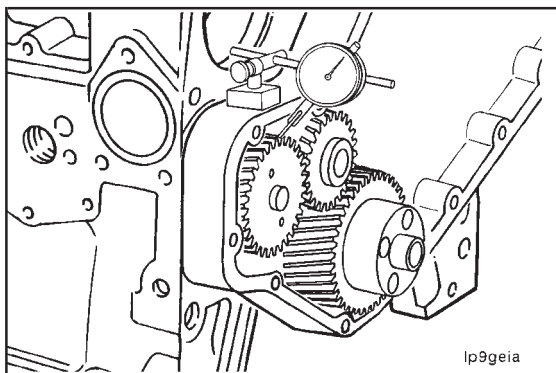

### Lube Pump - Removal (0-55)

#### Measuring Backlash (0-56)



Position the indicator on a tooth of the lube pump gear.

Note the lube pump gear backlash. Mark the lube pump gear and idler gear for additional analysis if the limits are exceeded.

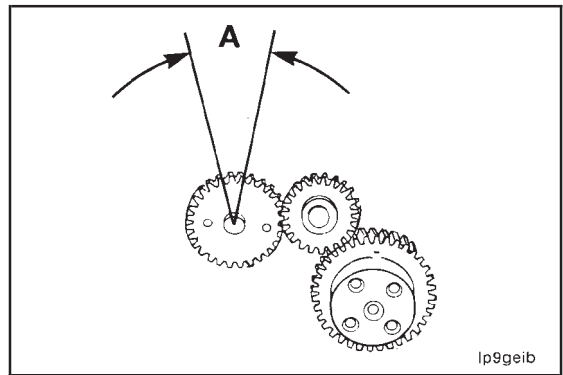

Lube Pump Gear Backlash Limits (A)		
mm		in
0.076	MIN	0.003
0.330	MAX	0.013

**NOTE:** Prevent movement of the adjoining gear when checking backlash or the reading will be the total of both gears.

Position the indicator on a tooth of the lube pump idler gear.

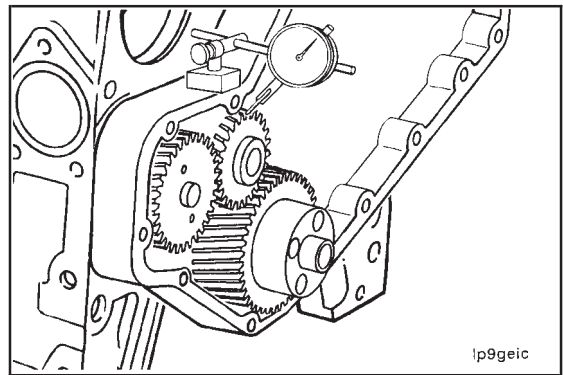

Note the idler gear backlash. Mark the idler gear and crankshaft gear for additional analysis if the limits are exceeded.

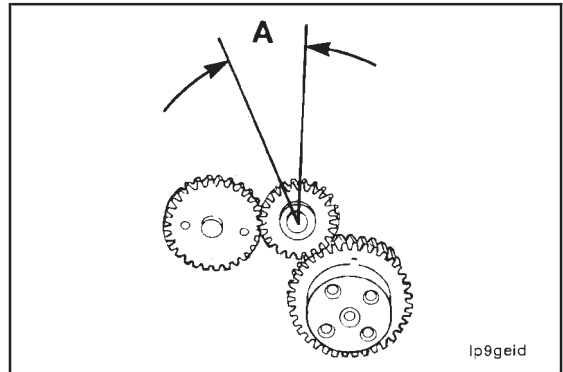

Lube Pump Idler Gear Backlash Limit (A)		
mm		in
0.076	MIN	0.003
0.330	MAX	0.013

**NOTE:** Prevent movement of the adjoining gear when checking backlash or the reading will be the total of both gears.

**13 mm**

Remove the lube pump.

**NOTE:** Refer to Component Section 7 for inspection.

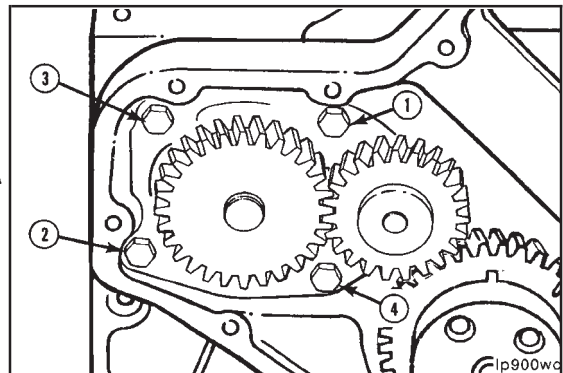

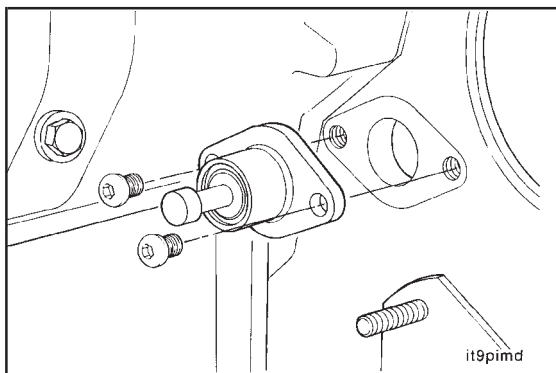

**T25 Torx**

Remove the timing pin assembly.



**Gear Housing - Removal (0-58)**

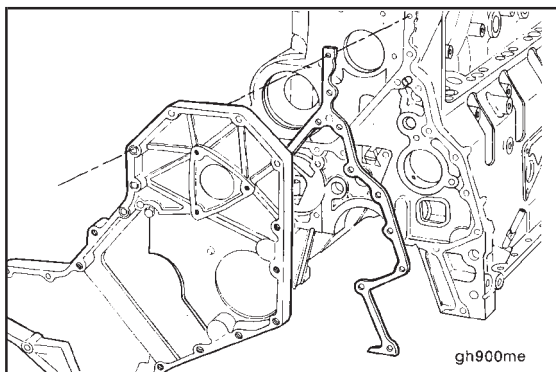

**10 mm**

Remove the capscrews, gear housing and gasket.

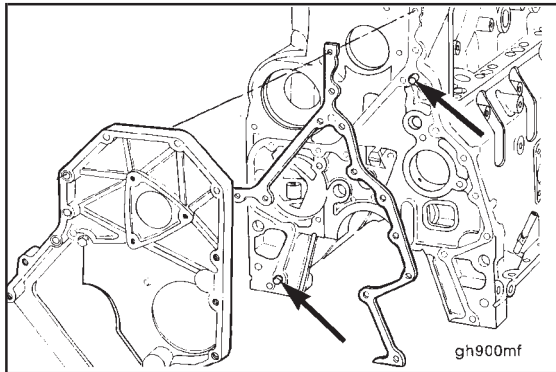

**Plastic Hammer**

The gear housing is positioned onto the cylinder block with two dowel pins. Tap in the area of the dowel pins with a plastic hammer if difficulty is encountered removing the housing.

### Balancer - Removal (0-59)

#### Measuring Backlash (0-60)

Use an indicator to measure the backlash of the idler gear (A) upper shaft gear (B) and lower shaft gear (C).

**NOTE:** Prevent movement of the adjoining gear when checking backlash or the reading will be the total of both gears.

Balancer Gear Backlash				
		mm		in
Idler	(A) to (D)	0.088	MIN	0.003
		0.420	MAX	0.017
Upper Shaft	(B) to (A)	0.153	MIN	0.006
		0.355	MAX	0.014
Lower Shaft	(C) to (B)	0.088	MIN	0.003
		0.420	MAX	0.017

Record for use during inspection. Refer to Component Section 1 for disassembly and rebuilt instructions.

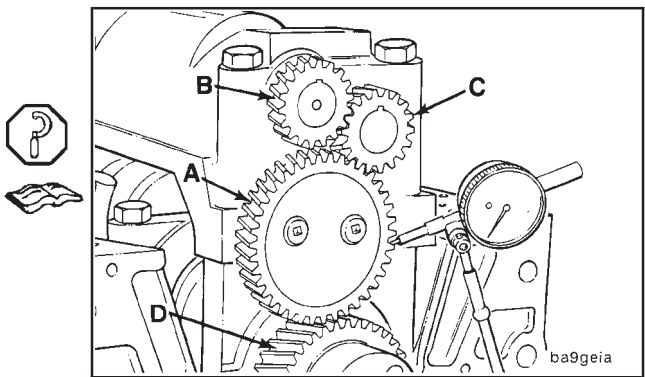

#### Measuring the End Play (0-61)

Use an indicator to measure the end play of the idler gear (D) and shaft (E).

Balancer End Play				
		mm		in
(D)		0.130	MIN	0.005
		0.630	MAX	0.024
(E)		0.075	MIN	0.003
		0.175	MAX	0.007

Record for use during inspection. Refer to Component Section 1 for disassembly and rebuilt instructions.

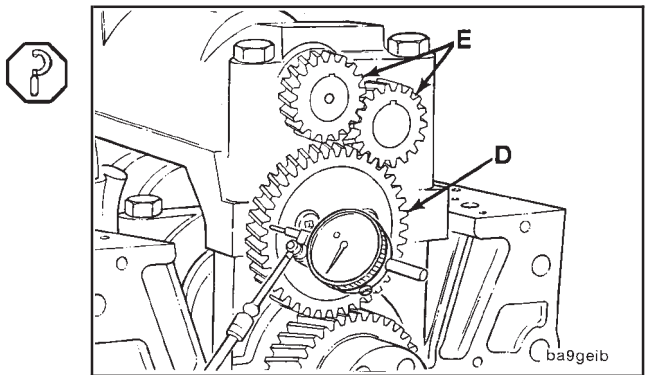

#### Locking the Balancer (0-62)

Rotate the balancer gears until the timing marks are aligned.

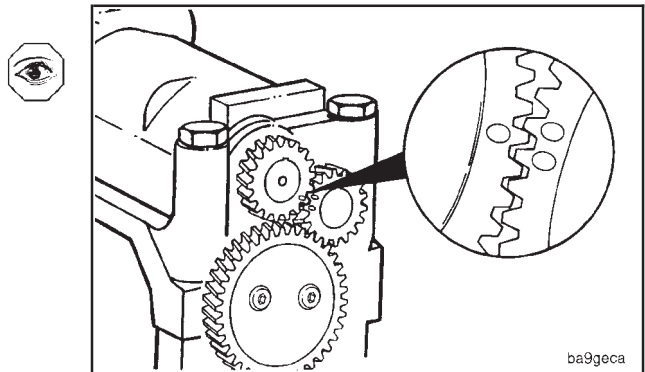

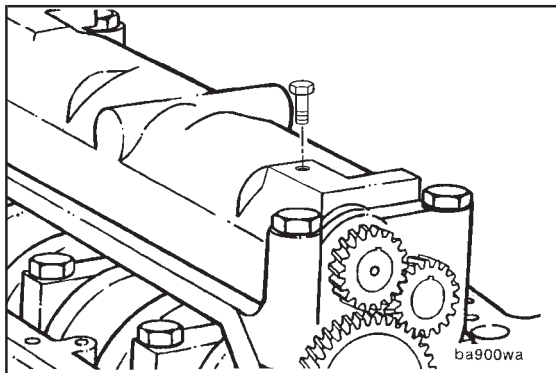

If the balancer shaft has a tapped hole, the shaft can be locked in position by temporarily installing a M8 capscrew through the housing and into the shaft.

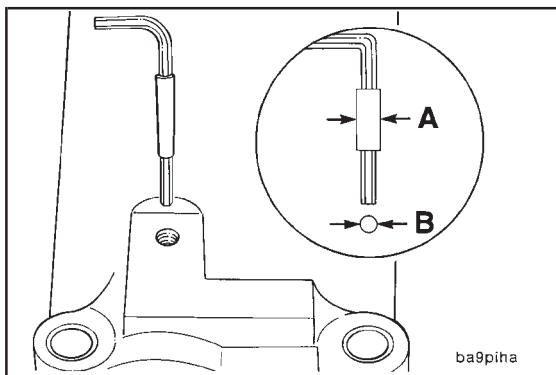

**4.5 mm Allen, 1 inch Wide Masking Tape**

Follow this procedure if the shaft does not have a tapped hole.

Wrap the 4.5mm allen wrench with masking tape until it has a snug fit in the hole in the balancer housing.

A = Approximately 10mm [0.4 inch]

B = 10mm [0.4 inch]

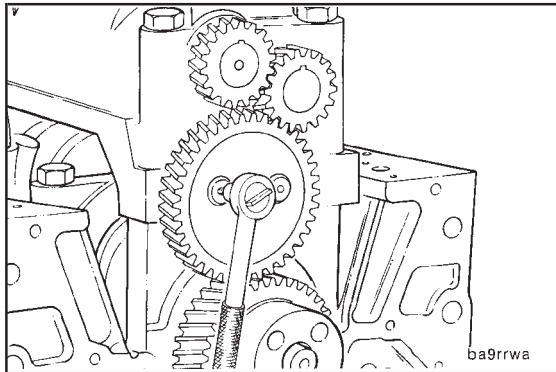

**Removing the Balancer (0-63)**

**8 mm Allen**

Loosen the socket head capscrews for the balancer idler gear retainer. **DO NOT REMOVE THE CAPSCREWS.**

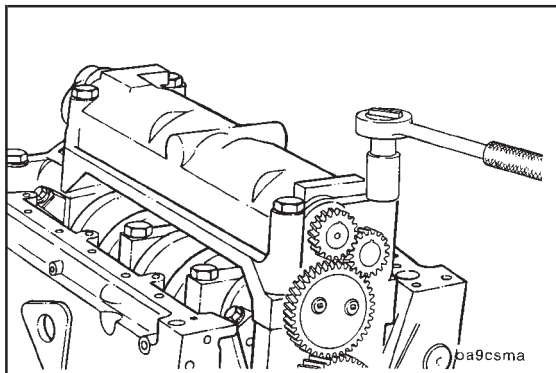

Remove the No. 1 and No. 4 main bearing capscrews.

Move the idler retainer until the pin in the No. 1 cap disengages the slot in the retainer. Remove the balancer assembly.

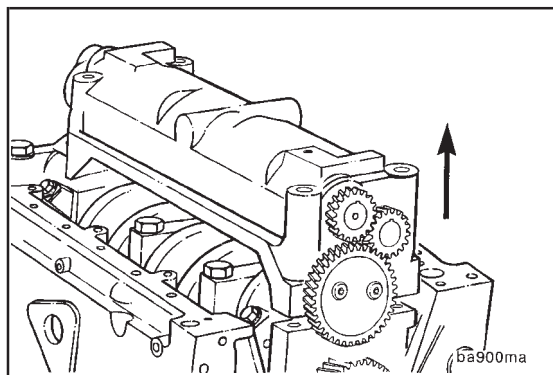

### Piston and Rod Assemblies - Removal (0-64)

Mark each rod cap according to cylinder.

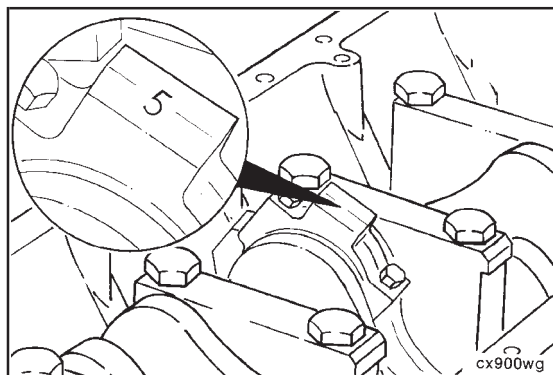

Rotate the engine on the rebuild stand so the cylinder bores are in a horizontal position.



Rotate the crankshaft so the pistons are below the carbon deposits above the ring travel area.

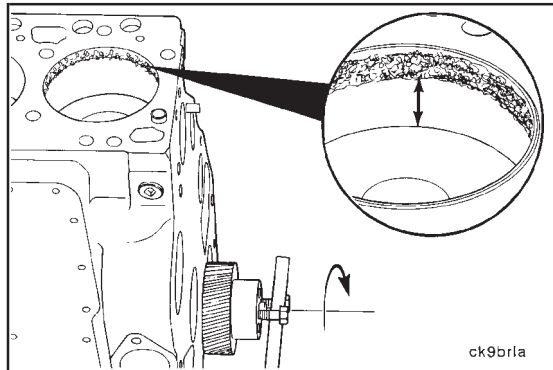

Use a scraper or a blunt edged instrument to loosen the carbon deposits. Do not damage the cylinder with the scraper.

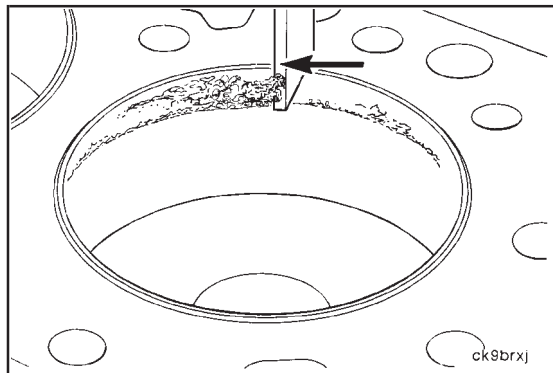



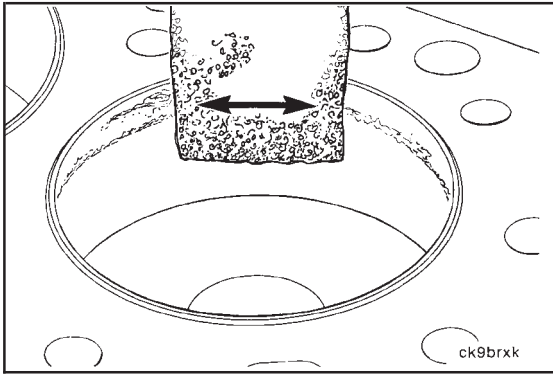

Remove the remaining carbon with a Scotch-Brite® cleaning pad or equivalent.

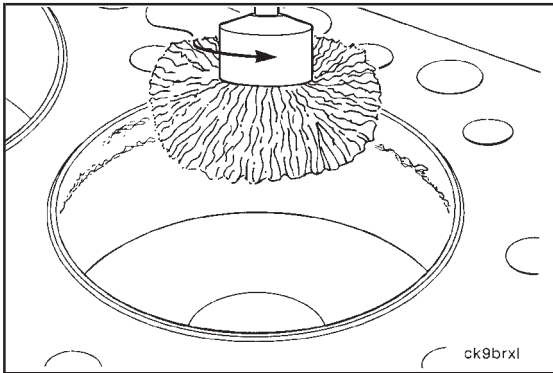

**Warning:** To prevent serious eye damage wear eye protection during this operation.



An alternative method to remove the carbon ridge is to use a high quality steel wire wheel installed in a drill or die grinder.

**NOTE:** An inferior quality wire wheel will lose steel bristles during operation, thus causing additional contamination.

**Do not use the steel wire wheel in the piston travel area. Operate the wheel in a circular motion to remove the deposits.**

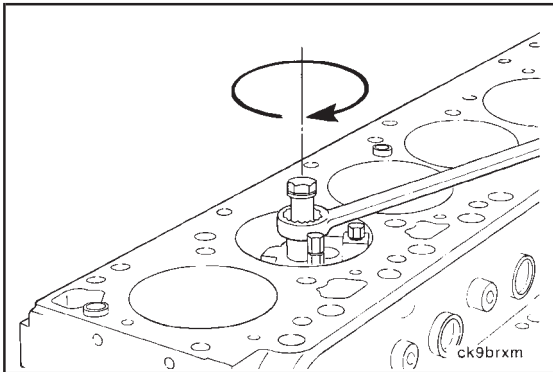

**Ridge Reamer**

If required, cut the ridge from the top of the cylinders.

**Make sure ridge reamer does not gouge into the cylinder bore or remove more metal than needed.**

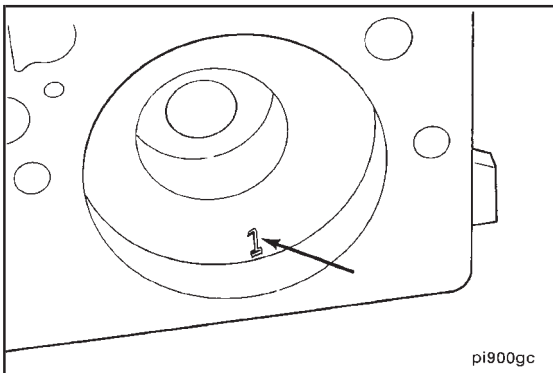

Mark each piston with the cylinder number.

During assembly, the piston **must** be installed into the corresponding cylinder number.

**12 mm**

Remove the capscrews, rod cap and rod bearings.

Mark the cylinder number on the back side of the rod bearings.

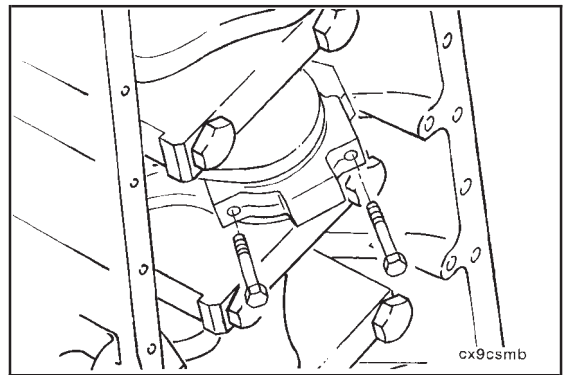

Catch the piston with one hand while pushing the rod and piston assembly out of cylinder bore. Care must be taken not to mutilate the connecting rod or bearing.

**NOTE:** Disassembly of the piston/rod assembly is described in Component Section 1.

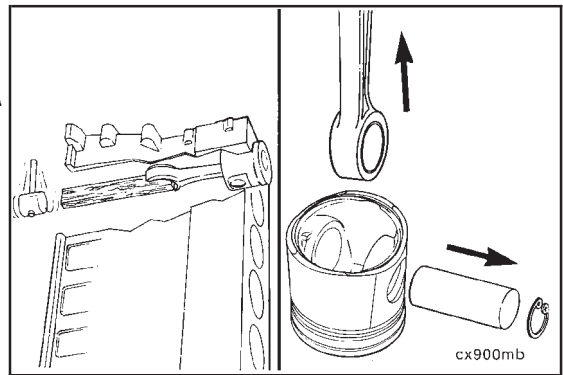

**Crankshaft - Removal (0-65)**

**23 mm**

Rotate the engine to a horizontal position so the main bearing caps are accessible. Remove the capscrews from the main bearing caps.

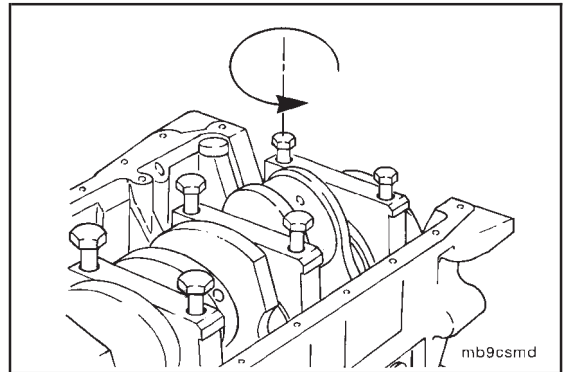

The main caps should be numbered. If they are not, mark them with the correct number.

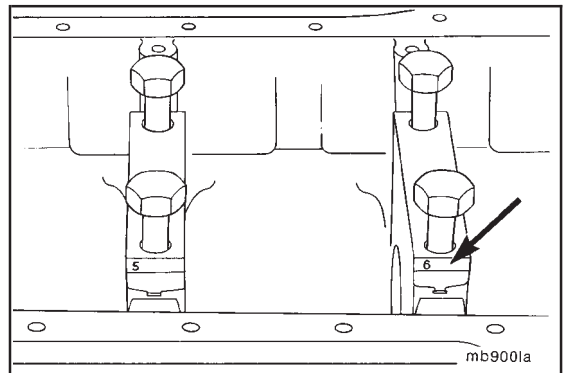

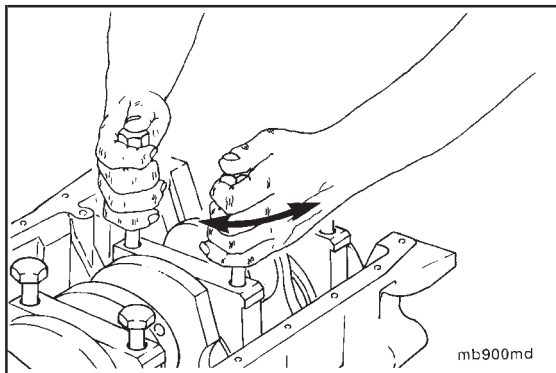

Remove the main bearing caps.

Do not pry on the main caps to free them from the cylinder block.

Use two of the main cap bolts to “wiggle” the main cap loose, being careful not to damage the bolt threads.

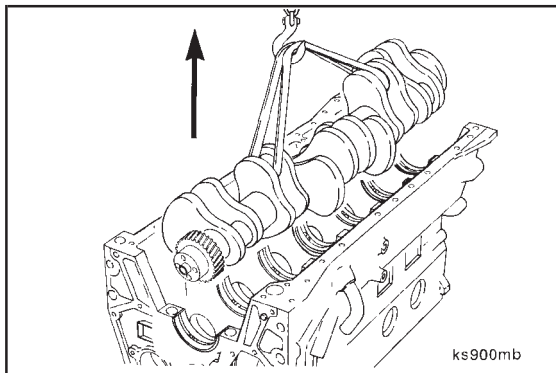

**Crankshaft Weight:**

- 4 Cylinder - 36 Kg [80 lb]
- 6 Cylinder - 55 Kg [123 lb]

Lift the crankshaft and gear from the cylinder block.

**NOTE:** Refer to Component Section 1 for disassembly and inspection.

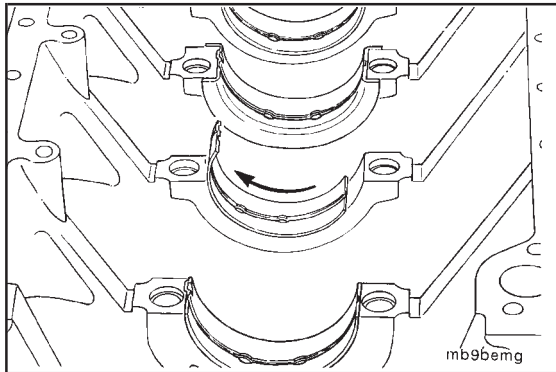

Remove the main bearings from the cylinder block and the main caps.

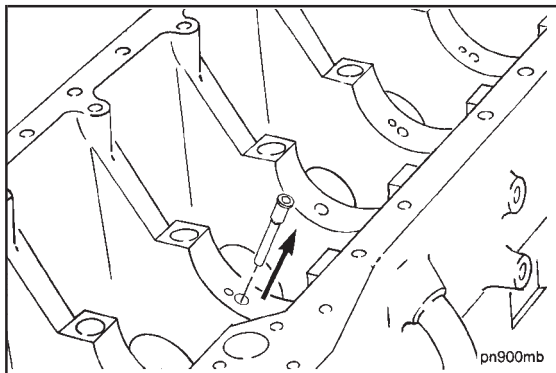

**3/16 Inch Pin Punch**

Remove the piston cooling nozzles.



Install the main caps in their corresponding positions. When correctly installed, the tangs (slots) should both be on the same side.



**NOTE:** #1 is to the front of the block.

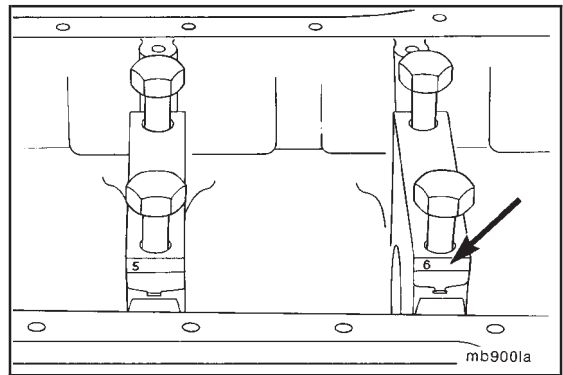

### Turbocharger Drain Tube - Removal (0-66)

3/4 Inch Drift & Hammer

Drive the drain tube out from the inside of the cylinder block.

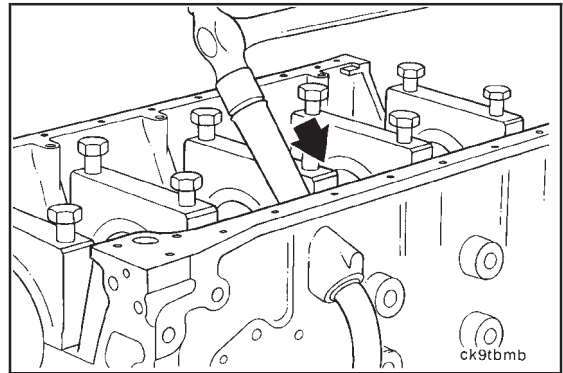

### Cylinder Block - Removing From the Rollover Stand (0-67)

18 mm

Remove the cylinder block from the rollover stand.

**NOTE:** Refer to Component Section 1 for cleaning and inspection of the cylinder block.

4B Cylinder Block Weight: 91 Kg [201 lb]  
6B Cylinder Block Weight: 124 Kg [275 lb]

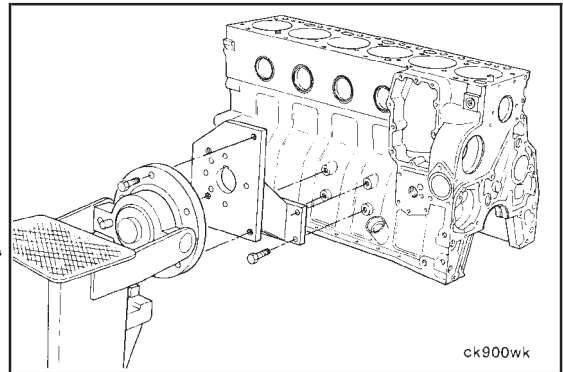

### Engine Assembly (0-68)

#### Cylinder Block - Prepare for Assembly (0-69)

Install the cylinder block to the rollover stand.

**NOTE:** Make sure the cylinder block has been cleaned and inspected as described in Component Section 1.

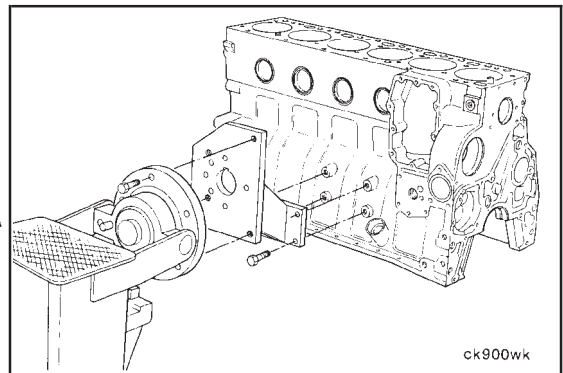

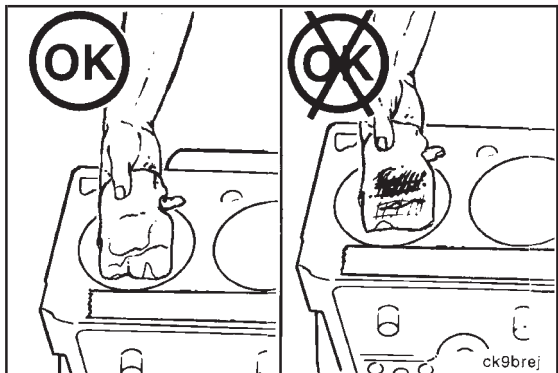

Caution: Be sure the cylinder bores are clean.

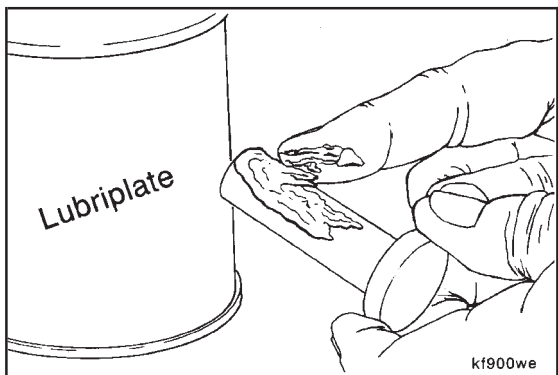

### Valve Tappets - Installation (0-70)

Lubricate the tappets with Lubriplate 105®.

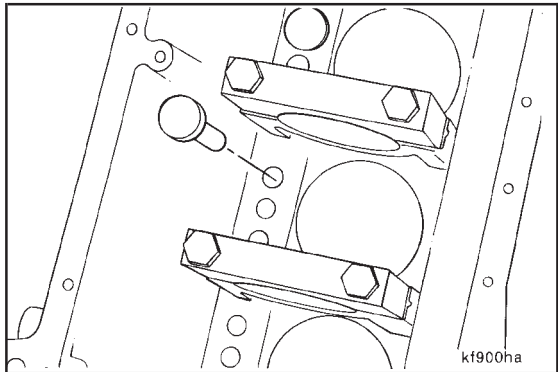

Install the valve tappets.

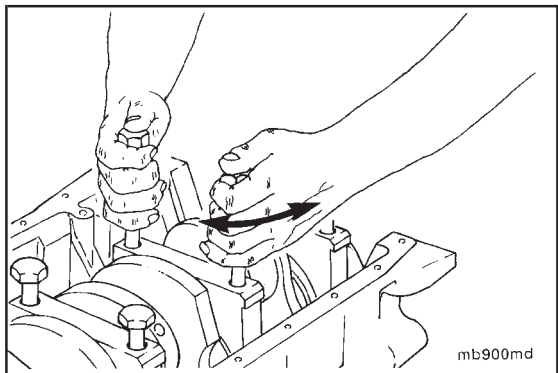

### Crankshaft - Installation (0-71)

23 mm

Remove the main bearing caps.



**1/2 Center Punch**

Install piston cooling nozzles even with or below the bearing saddle surface.

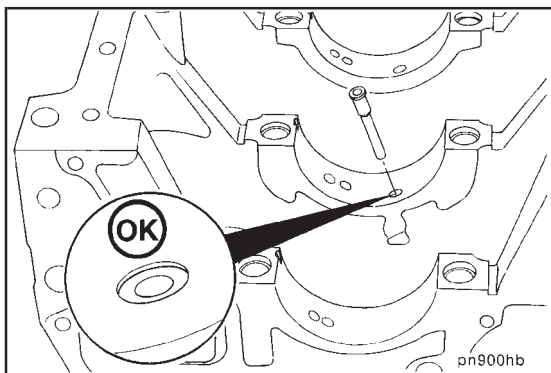

**Caution:** Be sure spray holes are clean and open.

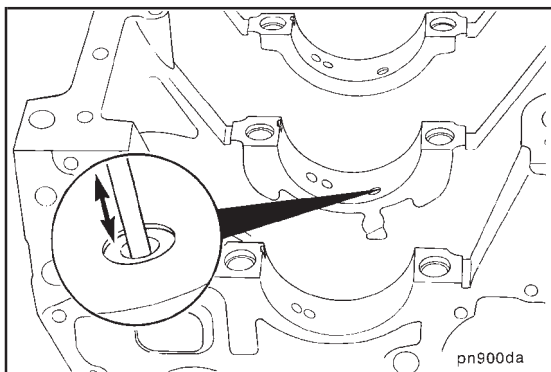

Install the upper main bearings.

Make sure the bearing tangs are in the notch in the bearing saddle.

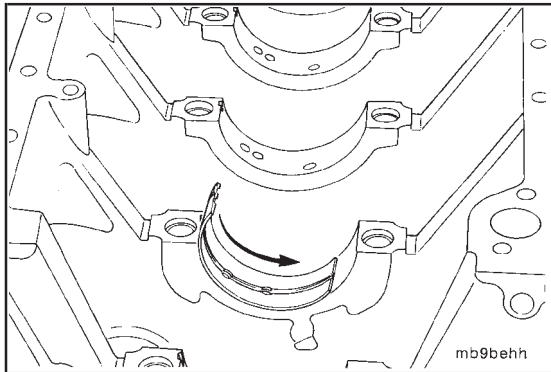

Install the combination thrust and main bearing in the second journal from the rear.

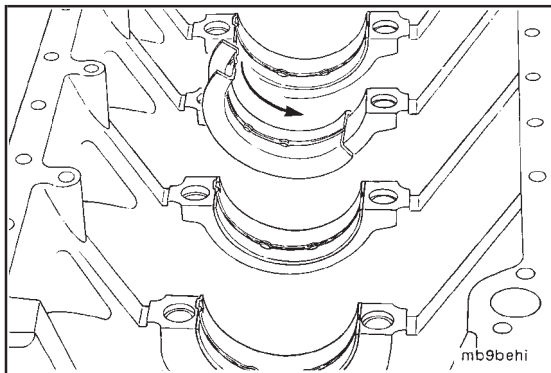

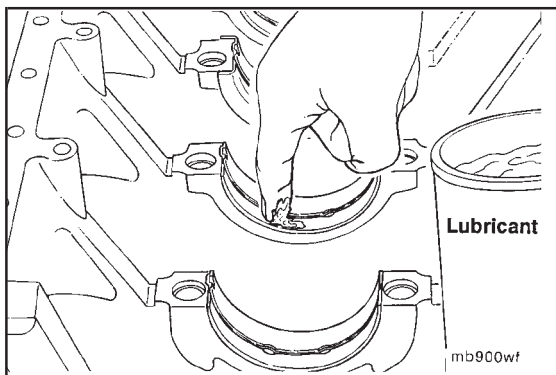

Lubricate the bearings with Lubriplate 105®.

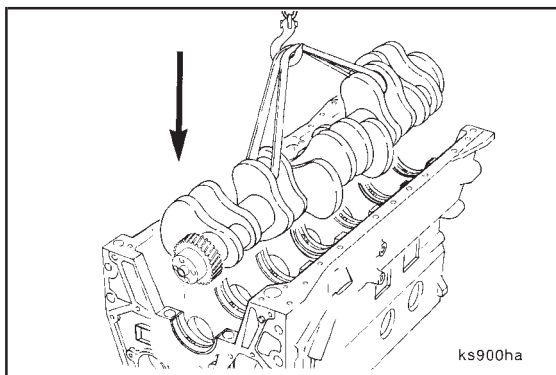

**Caution:** Carefully install the crankshaft to avoid damage to the crankshaft main bearings, especially the thrust/main bearing.



Install the crankshaft.



**Crankshaft Weight:**

- 4 Cylinder - 36 Kg [80 lb]
- 6 Cylinder - 55 Kg [123 lb]

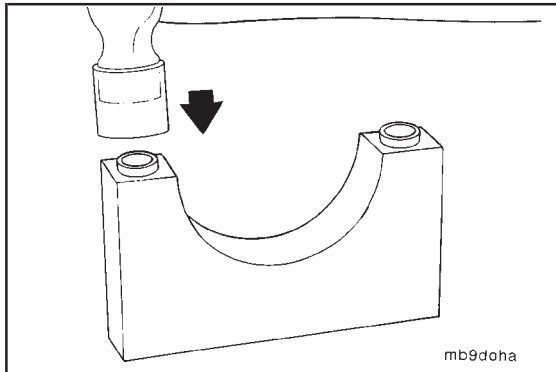

Make sure the ring dowels have been installed into the caps.

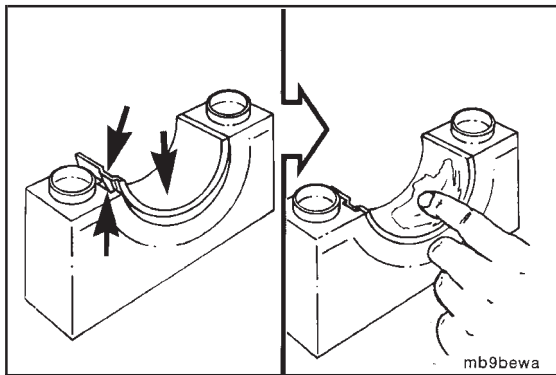

Install the lower main bearings into the caps.

Lubricate the bearings with Lubriplate 105®.

Make sure the bearing tangs are installed in the notch in the bearing cap.

The main bearing caps are numbered for location. Number 1 starts with the front of the block, and the numbers face the oil cooler side of the engine.

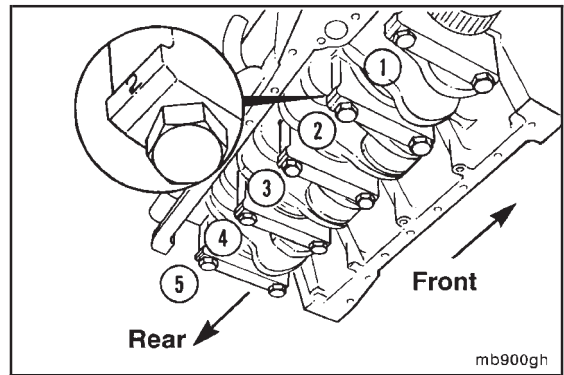

Position the main bearings and caps.

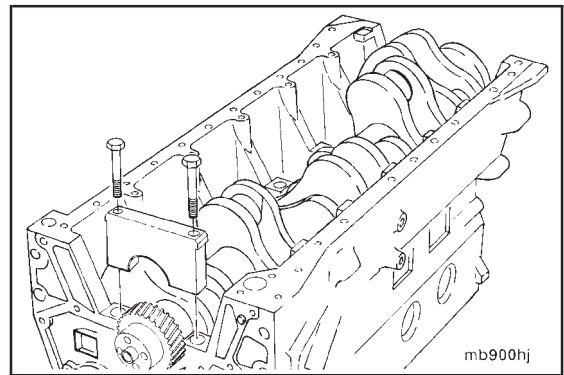

Lubricate the main bearing capscrew threads and underside of the head with clean engine oil.

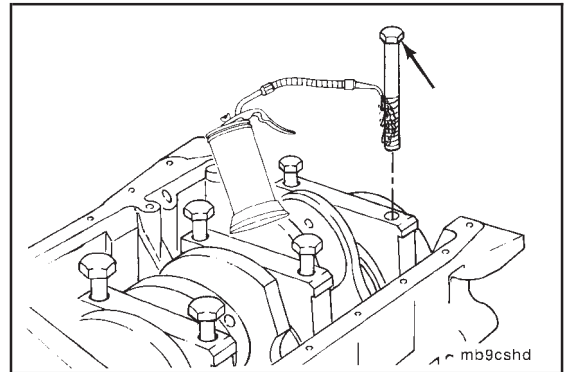

**23 mm**

Tighten the capscrews evenly following the illustrated sequence.

**NOTE:** When the engine is equipped with a balancer the main bearing caps cannot be torqued until the piston and rod assemblies are installed. It is also necessary to establish Top Dead Center before the balancers can be installed. If a balancer is to be installed at a later procedure install and tighten No. 2, 3, and 5 main bearing capscrews until the main bearing caps are seated and proceed to procedure (0-72).

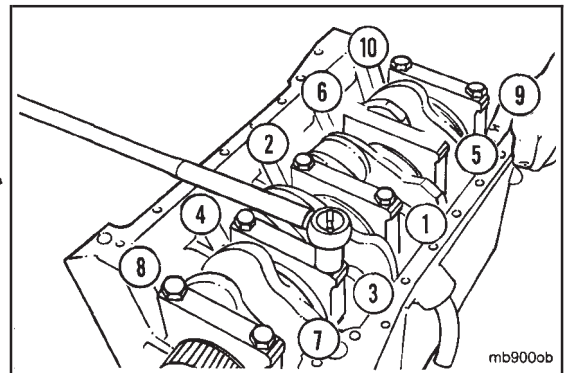



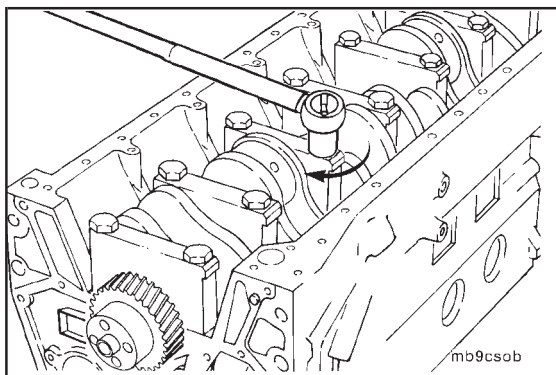

Follow these steps to tighten the capscrews.

Step	Torque Value
1	60 N•m [ 44 ft-lb]
2	119 N•m [ 88 ft-lb]
3	176 N•m [130 ft-lb]

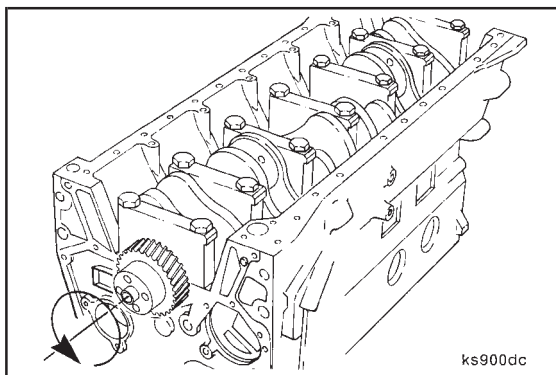

**The crankshaft must rotate freely.**

Check the bearing installations and the size of the bearings if the crankshaft does not rotate freely.

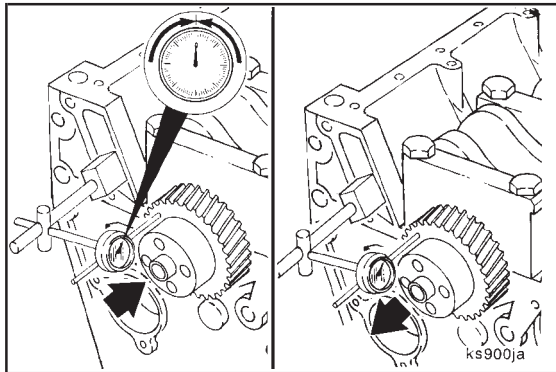

Position a dial indicator to measure crankshaft end play.

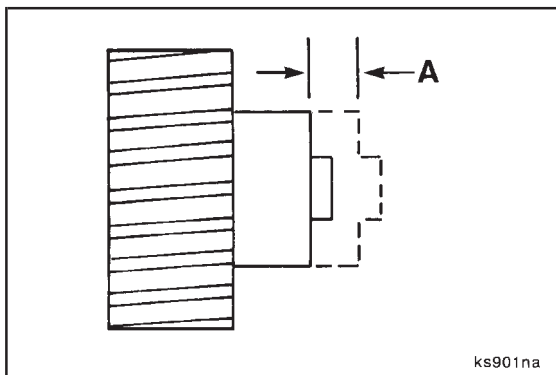

**The dimensions of the thrust bearing and crankshaft journal determine end play.**

Measure the end play.

Crankshaft End Play Limits (A)		
mm		in
0.102	MIN	0.004
0.432	MAX	0.017

## Piston and Rod Assemblies - Installation (0-72)

Rotate the engine on the stand until the crankshaft is vertical.

**NOTE:** If the engine is rotated more than 90 degrees, the tappets will fall out.

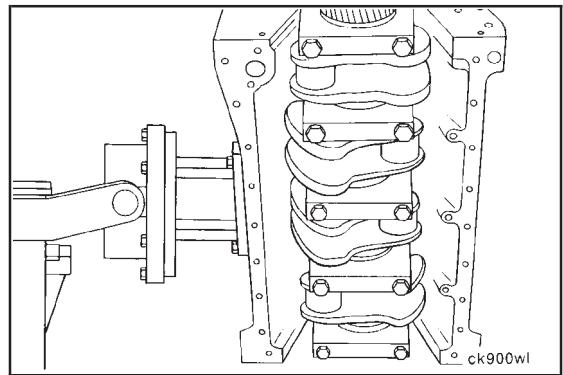

### Piston Grading For 1994 Automotive Applications Only

When rebuilding an engine with the original cylinder block, crankshaft, and pistons, make sure the pistons are installed in the original cylinder. If replacing the piston(s), make sure the replacement piston(s) are the same grade as the original piston. If a new cylinder block or crankshaft is used, the piston grading procedure **must** be performed to determine the proper piston grade for each cylinder.

Install the connecting rod/piston assembly into the No. 1 cylinder without the rings installed. Make sure the word "Front" on the top of the piston is toward the front of the cylinder block.

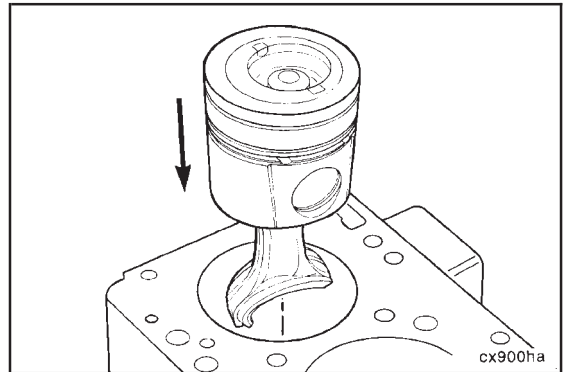

**NOTE:** The connecting rod bearing shells must be installed in the original connecting rod and cap.

Install the upper bearing shell in the connecting rod with the tang of the bearing in the slot of the connecting rod.

Use clean lubricating oil to coat the inside diameter of the connecting rod bearing shell.

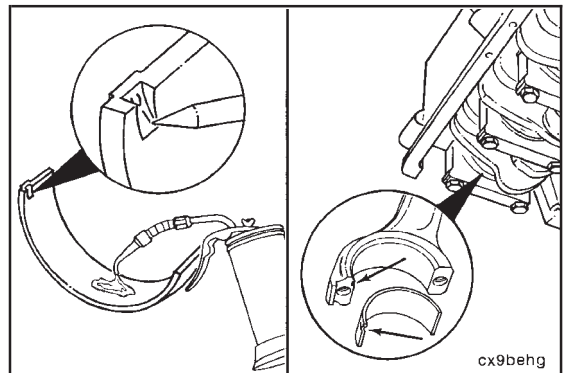

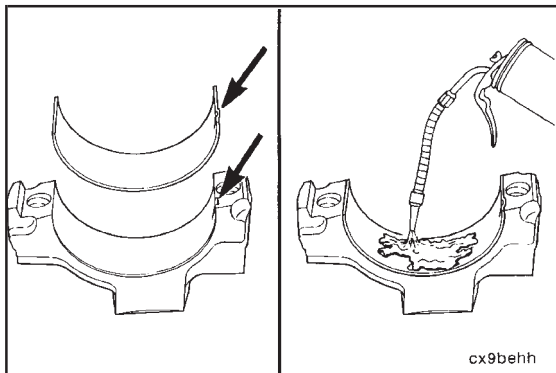

Install the bearing shell in the connecting rod cap with the tang of the bearing in the slot to the cap.



Use clean lubricating oil to coat the inside diameter of the bearing shell.

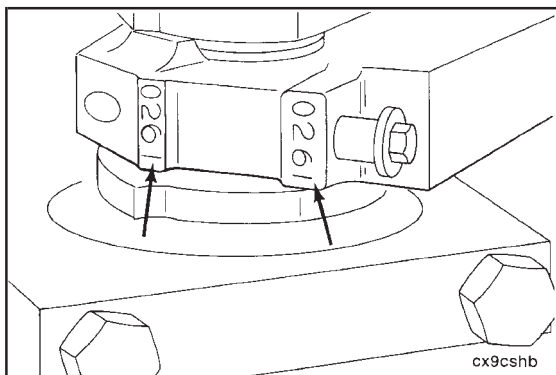

The four digit number stamped on the connecting rod and cap at the parting line must match and be installed on the oil cooler side of the engine.

Install the connecting rod cap and capscrews to the connecting rod.

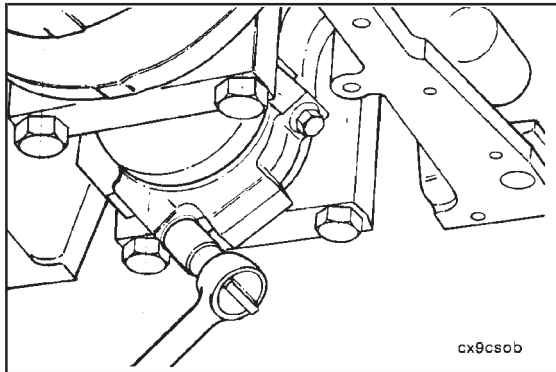

**12 mm, Torque Wrench**

Tighten the two capscrews.

**Torque Value:** 35 N•m [26 ft-lb]

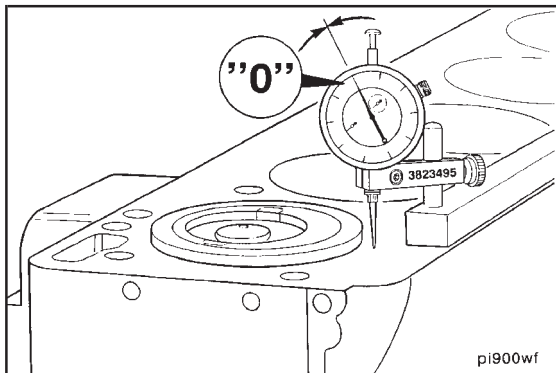

**3823495 Dial Indicator**

Use a fine grit stone to remove any burrs from the cylinder block head deck.

Zero "0" the dial indicator to the cylinder block head deck.

Move the dial indicator over the piston directly over the piston pin to eliminate any side-to-side movement. Do not place the indicator tip on the anodized area.

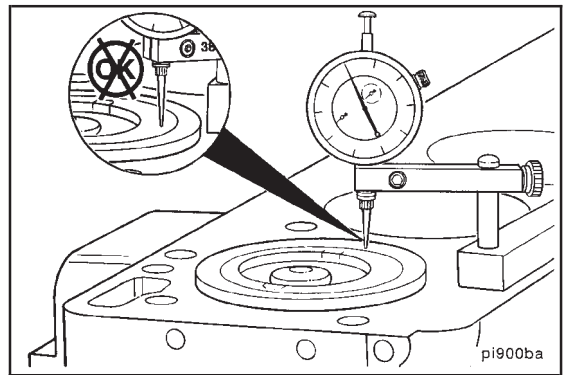

Rotate the crankshaft to top dead center (TDC). Rotate the crankshaft clockwise and counterclockwise to find the highest dial indicator reading.

Record the reading.

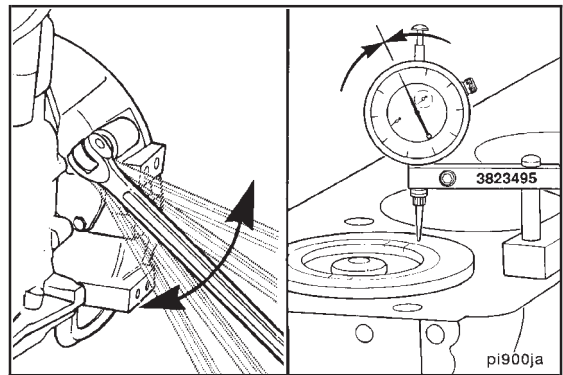

Remove the piston/connecting rod assembly from the No. 1 cylinder and install the assembly into the No. 2 cylinder. Repeat the procedure for every cylinder using the same piston/connecting rod assembly.

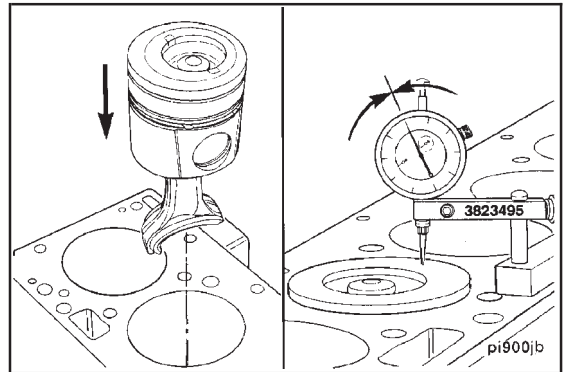

Determine the grade of the piston being used by referring to the chart.

Four digits on top of the piston are the last four digits of the part number.



NG	PROTRUSION	USE GRADE	PART NUMBER	
			160/175	190/230
.024-.028 (.609mm-.711mm)		A	3922571	3922577
.020-.024 (.508mm-.609mm)		B	3922572	3922578
.016-.020 (.406mm-.508mm)		C	3922573	3922579
.028-.032 (.711mm-.813mm)		A	3922571	3922577
.024-.028 (.609mm-.711mm)		B	3922572	3922578
.020-.024 (.508mm-.609mm)		C	3922573	3922579
.032-.036 (.813mm-.914mm)		A	3922571	3922577
.028-.032 (.711mm-.813mm)		B	3922572	3922578
.024-.028 (.609mm-.711mm)		C	3922573	3922579

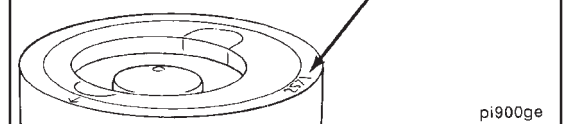

**PISTON PROTRUSION**

MEASURING PISTON	MEASURED PROTRUSION	USE GRADE	PART NUMBER	
			160/175	190/230
A	.024-.028 (.609mm-.711mm)	A	3922571	3922577
A	.020-.024 (.508mm-.609mm)	B	3922572	3922578
A	.016-.020 (.406mm-.508mm)	C	3922573	3922579
B	.028-.032 (.711mm-.813mm)	A	3922571	3922577
B	.024-.028 (.609mm-.711mm)	B	3922572	3922578
B	.020-.024 (.508mm-.609mm)	C	3922573	3922579
C	.032-.036 (.813mm-.914mm)	A	3922571	3922577
C	.028-.032 (.711mm-.813mm)	B	3922572	3922578
C	.024-.028 (.609mm-.711mm)	C	3922573	3922579

The specification for Piston Protrusion is 0.024 to 0.028 inch for emission controlled engines built after 1-1-94.

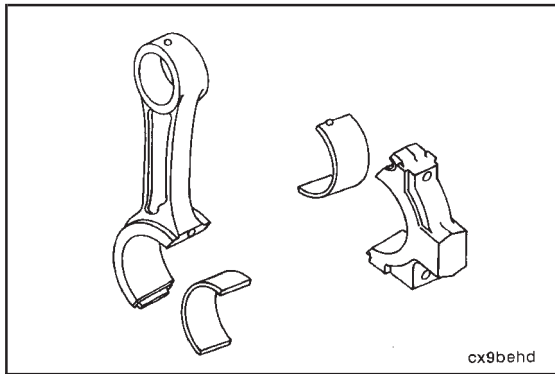

**Piston and Connecting Rod Assemblies - Installation**

Install the bearing shells into both the rod and the cap. Make sure the tang on the bearing shells is in the slot of the cap and rod.

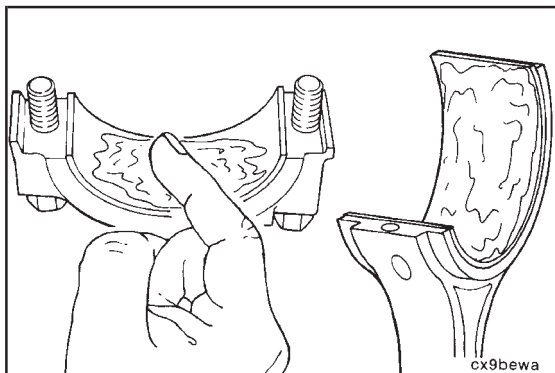

Lubricate the rod bearings with a light film of Lubriplate 105®.

Lubricate the rings and piston skirts with clean engine oil.

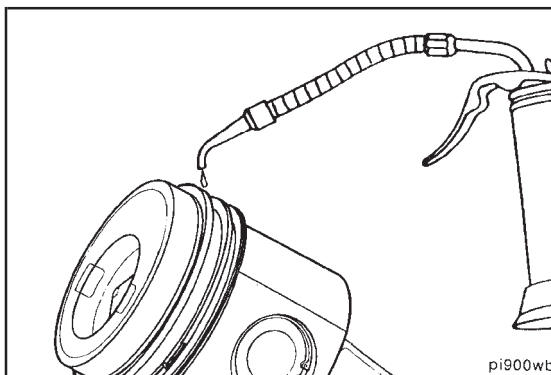

pi900wb

Position the rings.

**NOTE:** Refer to component section 01 for installation of rings on pistons.

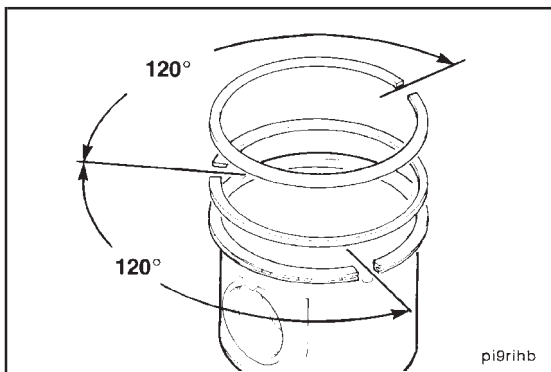

pi9rihb

75 - 125 mm [3-5 inch] ring compressor

**Caution:** If using a strap type ring compressor, make sure the inside end of the strap does not hook on a ring gap and break the ring.

Compress the rings.

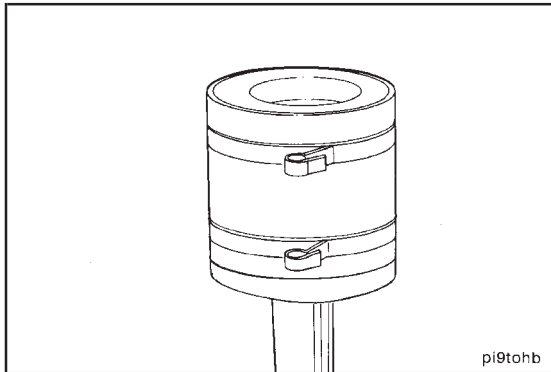

pi9tohb

Lubricate the cylinder bore with clean engine oil.

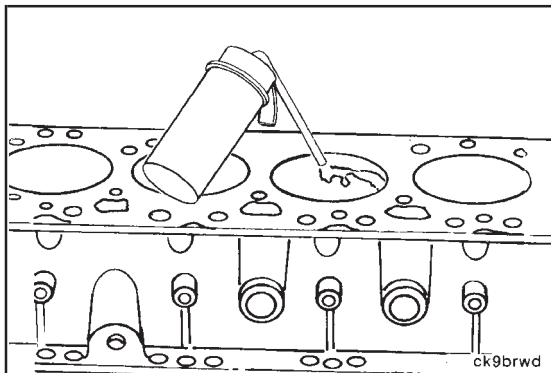

ck9brwd

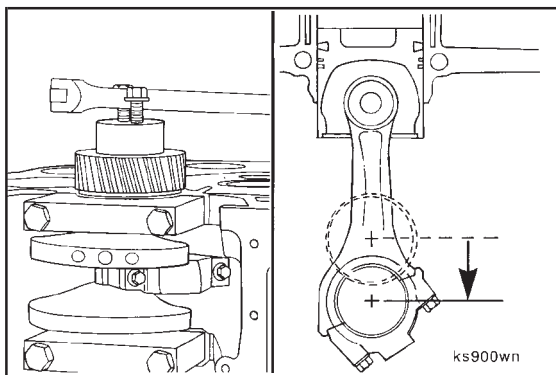

Position the rod journal for the piston to be installed to bottom dead center (BDC).

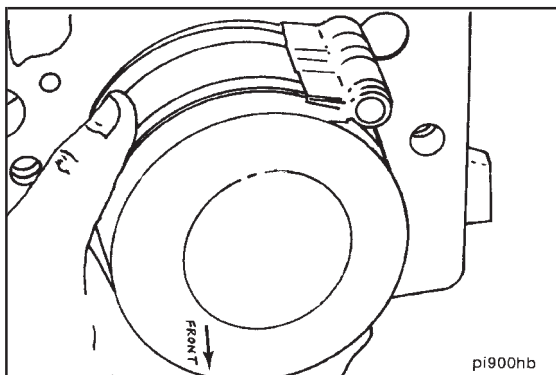

**Caution:** Take care not to damage the cylinder wall when inserting the connecting rod.



Position the piston and rod assembly into cylinder bore with the word "front" on piston towards the front of the cylinder block.

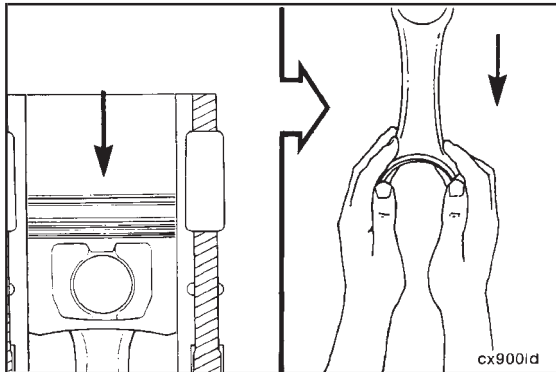

Carefully push the piston into the bore while guiding the connecting rod to the crankshaft journal.

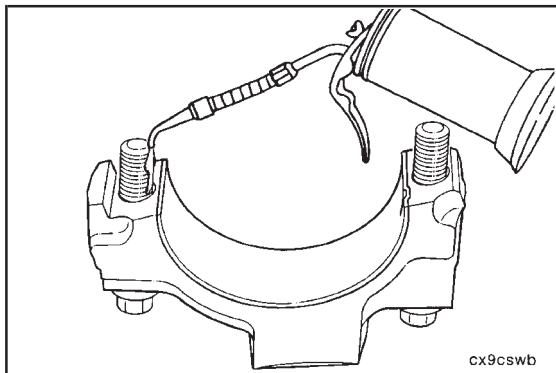

Lubricate the threads and underside of the connecting rod capscrew heads with engine oil.

**Caution:** The four digit number stamped on the rod and the cap at the parting line must match and be installed on the oil cooler side of the engine.

Install the rod cap and capscrews to the connecting rod.

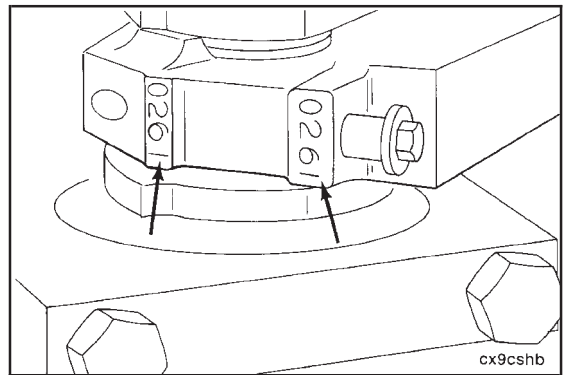

12 mm, Torque Wrench

Alternately, tighten the two capscrews

Step	Torque Value
1	35 N•m [26 ft-lb]
2	70 N•m [52 ft-lb]
3	100 N•m [74 ft-lb]

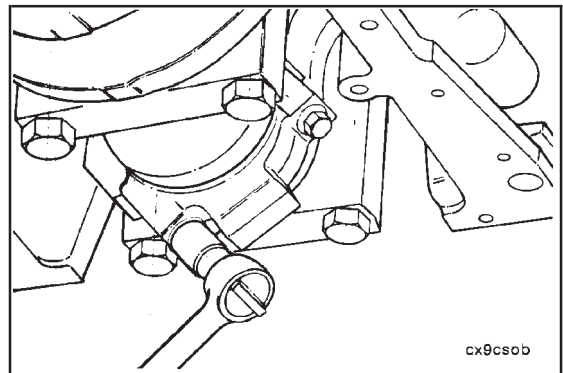

Measure the side clearance between the **connecting rod** and **crankshaft**.

**Do not** measure the clearance between the rod cap and crankshaft.



Side Clearance Limits		
mm		in
0.10	MIN	0.004
0.30	MAX	0.012

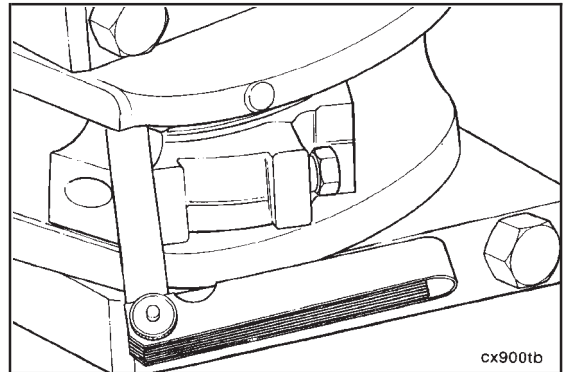

**Caution:** The crankshaft must rotate freely.

Check for freedom of rotation as the rod caps are installed. If the crankshaft does not rotate freely, check the installation of the rod bearings and the bearing size.

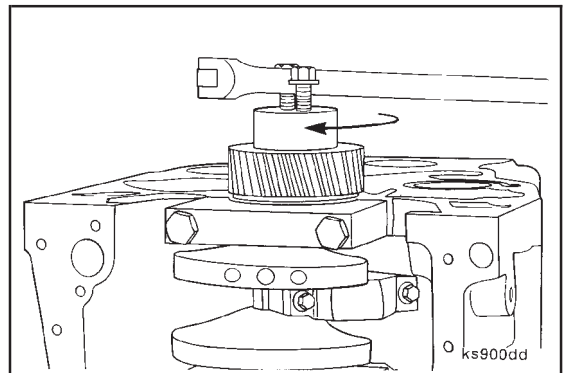



### Gear Housing - Installation (0-73)

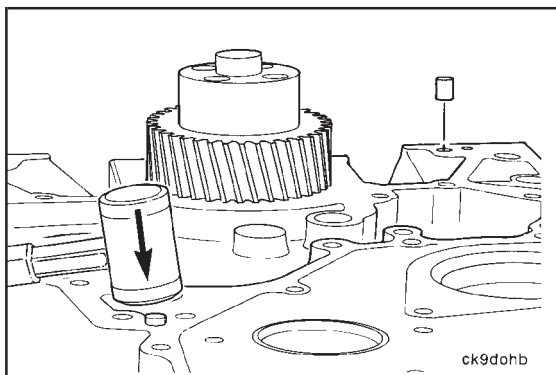

**Mallet**

If removed, install the two gear housing dowel pins.

The tapered end of the dowel fits into the cylinder block; install the pin to the bottom of the hole.

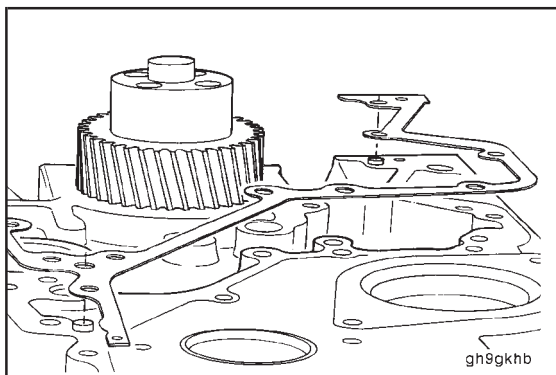

Install the gear housing gasket.

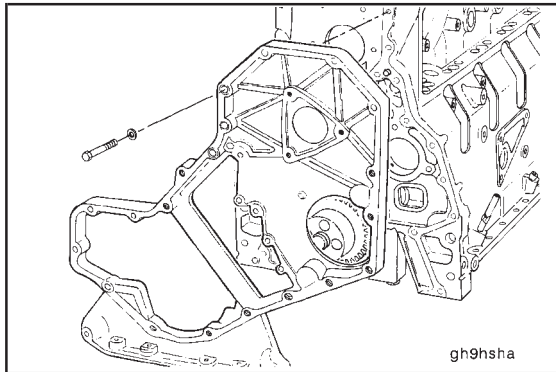

**10 mm**

Install the gear housing and cap screws.



Apply Loctite 205 to the cap screws.



**Torque Value:** 24 N•m [18 ft-lb]

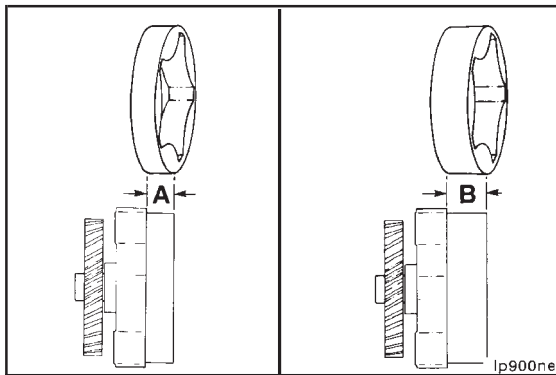

**Caution:** Make sure the correct pump is installed. The 4 cylinder pump and 6 cylinder pump are not interchangeable.

A = Four cylinder gerotor size  
12.947mm [0.516 inch]

B = Six cylinder gerotor size  
17.947mm [0.715 inch]

### Lube Pump - Installation (0-74)

Lubricate the pump with clean engine oil.

**Caution:** Fill the lube pump before installation to aid with priming during engine start up.

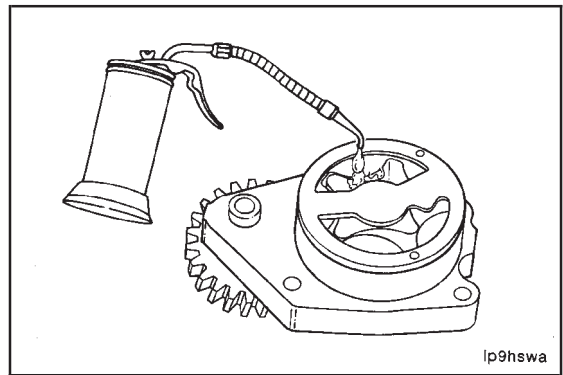

lp9hswa

The idler gear pin fits into a locating bore in the cylinder block.

Install the lube pump.

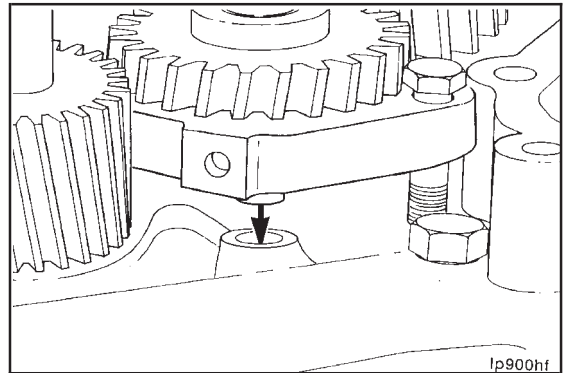

lp900hf

The sealing plate on the back of the pump will seat on the cylinder block and the capscrews **should not** draw the flange up to the block.

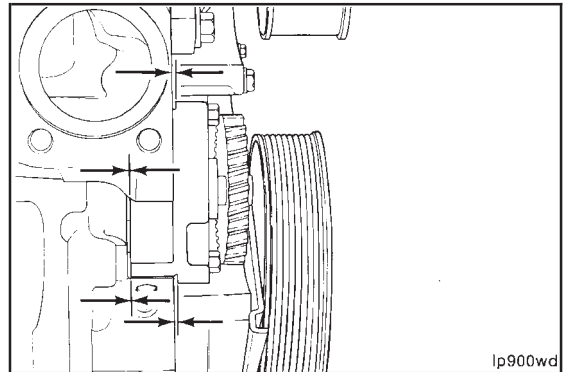

lp900wd

13 mm

Tighten the capscrews in the sequence shown.

**Torque Value:** 24 N•m [18 ft-lb]

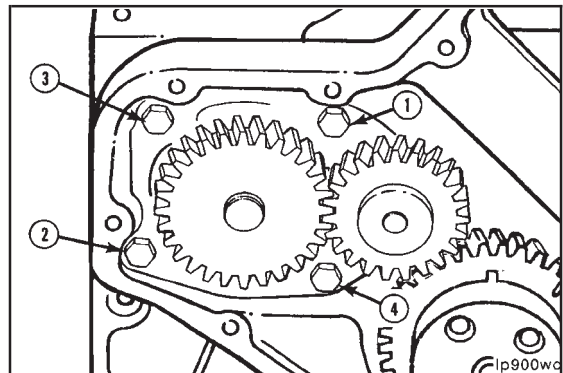

lp900wc

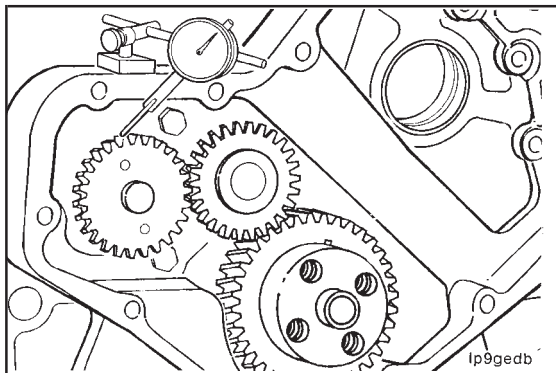

**Caution:** Be sure the gear backlash is correct if installing a new pump.



Use a dial indicator to measure gear backlash.

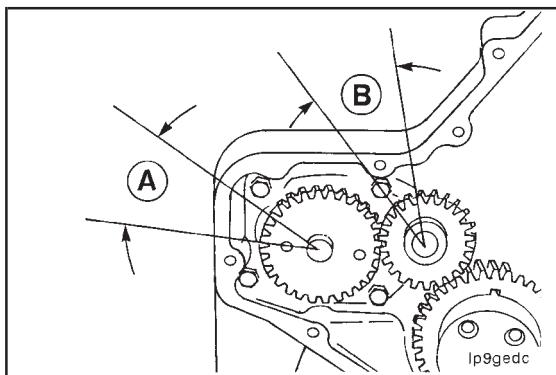

Measure gear backlash.

Backlash Limits	
A	B
0.08 to 0.33 mm [.003 to .013 in]	0.08 to 0.33 mm [.003 to .013 in]

**NOTE:** Prevent movement of adjoining gears when checking backlash or the reading will be the total of both gears.

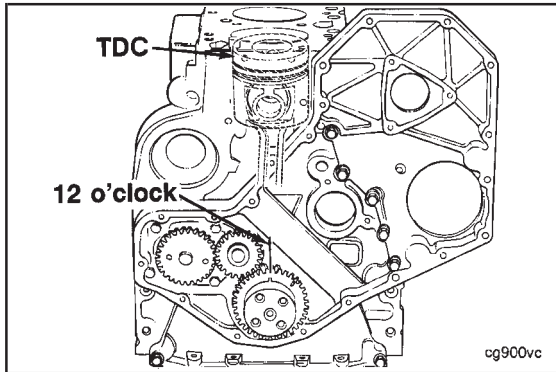

### Camshaft - Installation (0-75)

Rotate the crankshaft until the number one cylinder is approximately at the TDC position. When properly positioned, the crankshaft gear alignment pin will be positioned in the 12 o'clock position.

**NOTE:** If the crankshaft is not properly positioned, the camshaft may contact the connecting rods during installation.

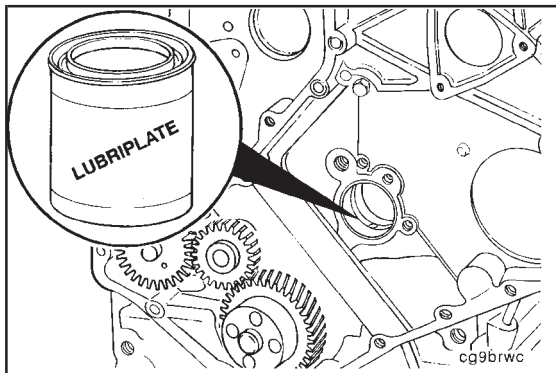

Lubricate the camshaft bores with Lubriplate.



**NOTE:** If cam bushing has not been installed, refer to Component Section 1 for procedure.

Lubricate the camshaft journals and lobes with Lubriplate 105®.

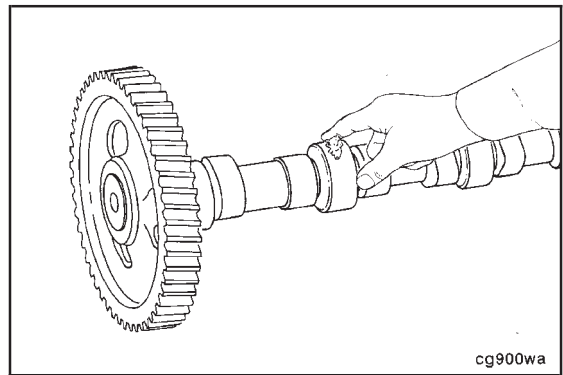

Position the camshaft/cam gear assembly into the cylinder block up to the last journal.

Refer to section 1 for assembly of cam gear on the camshaft.

Install the camshaft. While pushing in slightly, rotate the camshaft and carefully work the camshaft through the camshaft bushings. As each camshaft journal passes through a bushing, the camshaft will drop slightly and the camshaft lobes will catch on the bushings. Rotating the camshaft will free the lobe from the bushing and allow the camshaft to be installed.

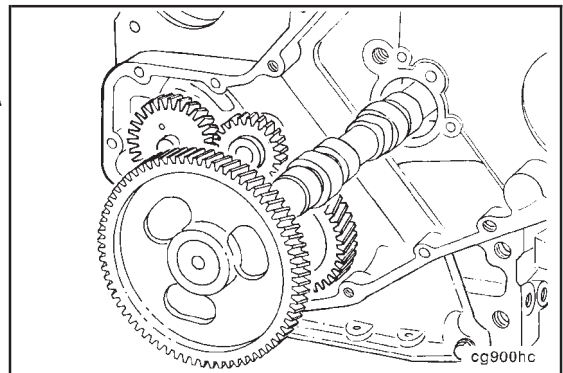

Before the camshaft gear is engaged with the crankshaft gear, check the camshaft for ease of rotation. When installed correctly, the camshaft will rotate freely.

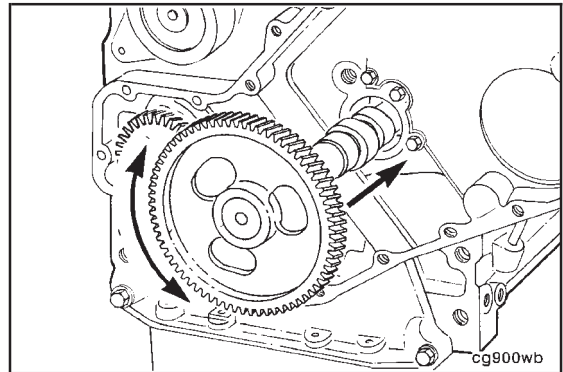

Lubricate the thrust plate with Lubriplate 105®.

Align the timing marks as illustrated and install the thrust washer.

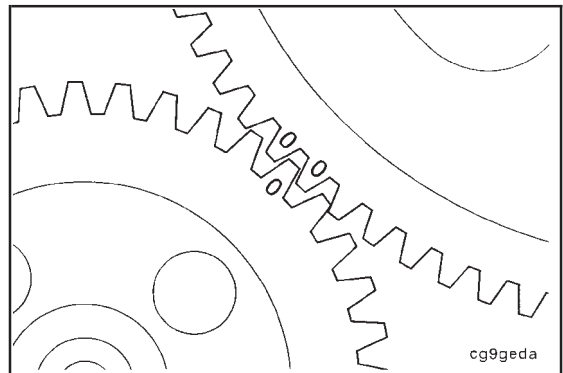

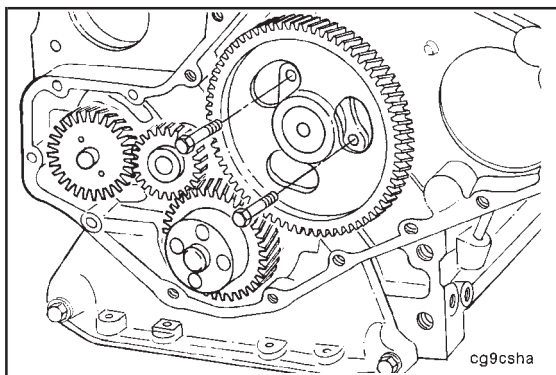

13 mm

Push the camshaft into the cylinder block and install the thrust plate cap screws.



Torque Value: 24 N•m [18 ft-lb]

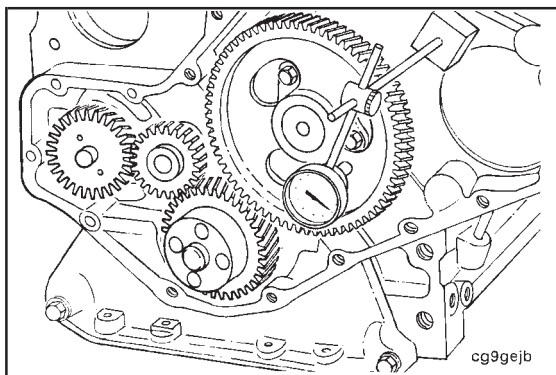

Measure the camshaft end play.

End play is controlled by the thickness of the thrust plate and the groove in the camshaft.

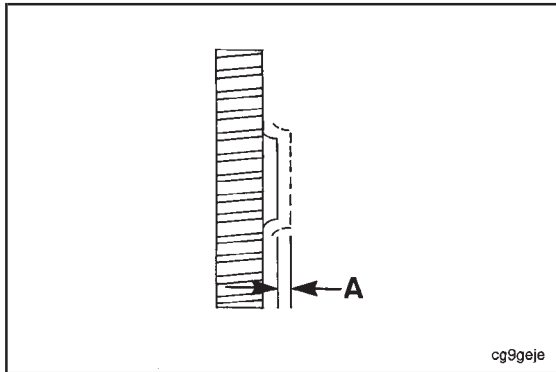

**Camshaft End Play - Measuring (0-76)**

Camshaft End Play Limits (A)		
mm		in
0.12	MIN	0.005
0.34	MAX	0.013

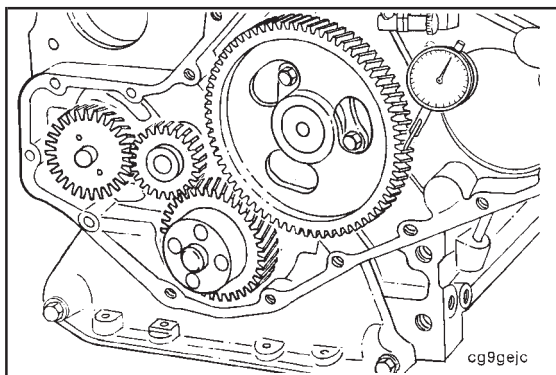

**Caution:** Be sure the backlash is correct for any replaced gears.



Use an indicator to measure backlash.

**Camshaft Gear Backlash - Measuring (0-77)**



Camshaft Backlash Limits (A)		
mm		in
.076	MIN	0.003
.380	MAX	0.013

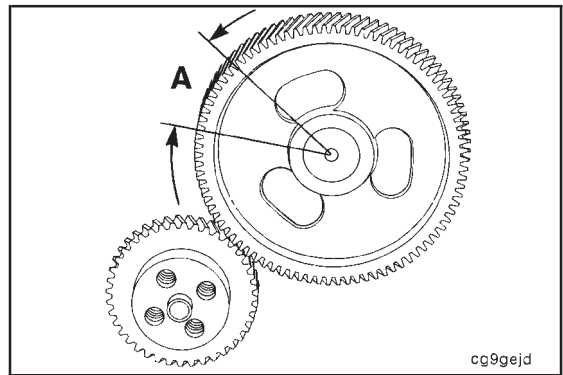

**Timing Pin - Installation (0-78)**

**Caution:** The timing pin assembly is precisely located on the gear housing to correspond to TDC for Cylinder Number 1.



**Caution:** The timing pin assembly must be relocated if gear housings are interchanged.

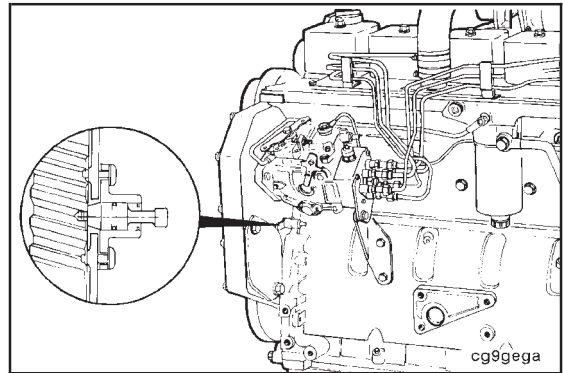

**10 mm, 15 mm**

Rotate the cylinder block on the rebuild stand until the combustion deck is positioned at the top and parallel to the floor.



To relocate the assembly, temporarily install the crankshaft pulley and a fabricated wire pointer. Put a flat washer between the pointer and gear housing to prevent damage to the gear housing.

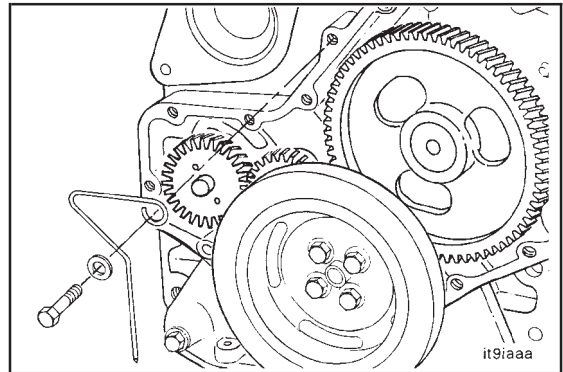

Fabricate a steel plate as shown in the illustration.

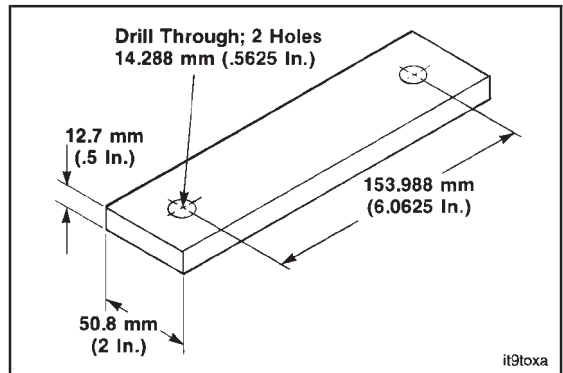

Timing Pin - Installation (0-78)  
Page 0-60

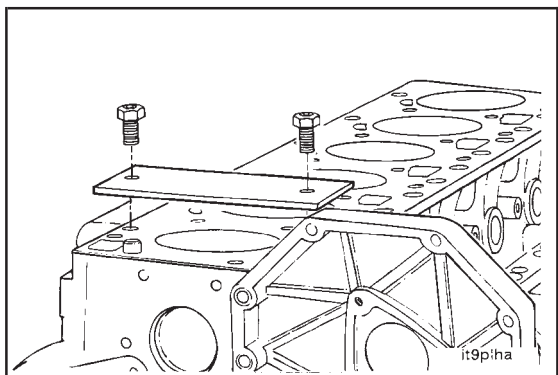

15 mm

Use two flywheel housing capscrews to assemble the plate over Cylinder Number 1.

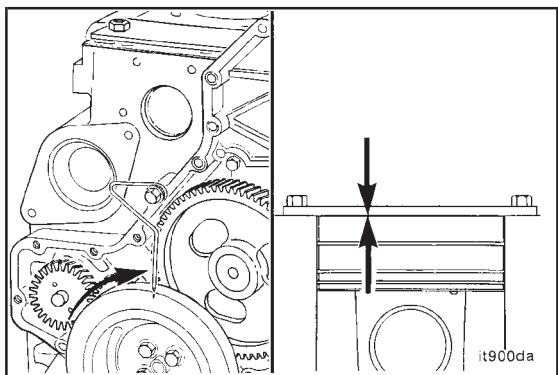

Rotate the crankshaft until the piston contacts the plate.  
Mark the pulley.

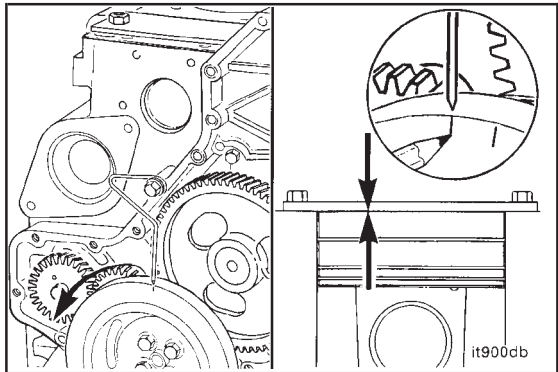

Rotate the engine in the opposite direction until the piston contacts the plate.  
Mark the pulley.

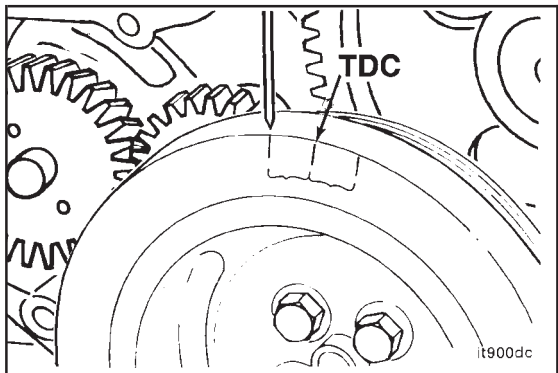

Mark the pulley for TDC which is one-half the distance between the first two marks.

**15 mm**

Remove the plate and rotate the engine until the pointer aligns with the TDC mark.

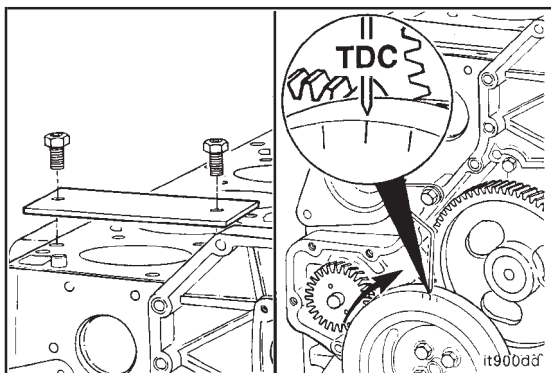

Look for the timing pin hole in the camshaft gear. If it is not visible, rotate the crankshaft one complete turn and align the pointer with the TDC mark.

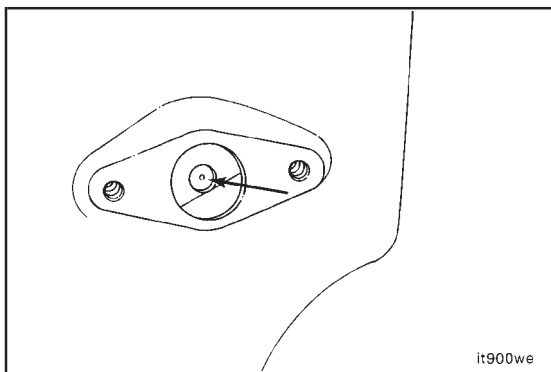

**T-25 Torx**

Install the timing pin assembly.

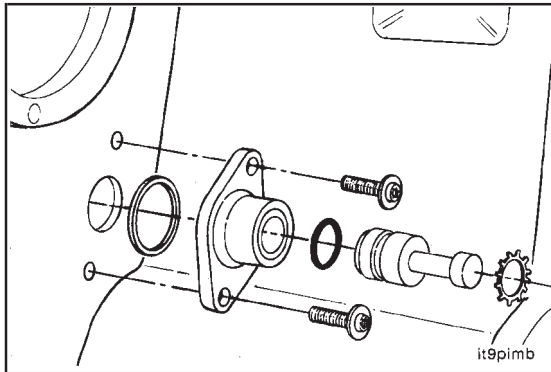

Push the pin into hole in the cam gear to align the housing.

Hold the pin in while tightening the torkscrews.

**Torque Value:** 5 N•m [48 in-lb]

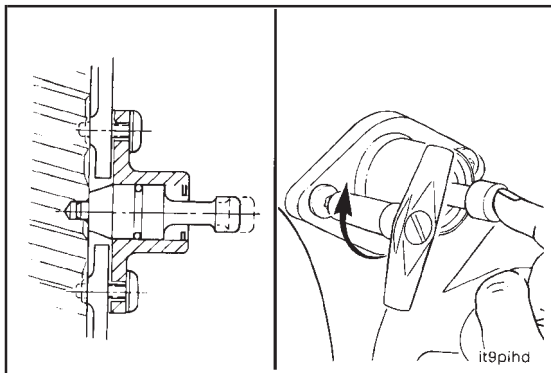



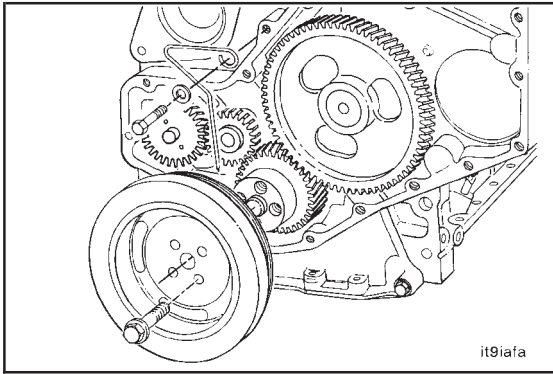

10 mm, 15 mm

**Caution:** Be sure timing pin is disengaged before rotating the engine.



Remove the crankshaft pulley and wire pointer.

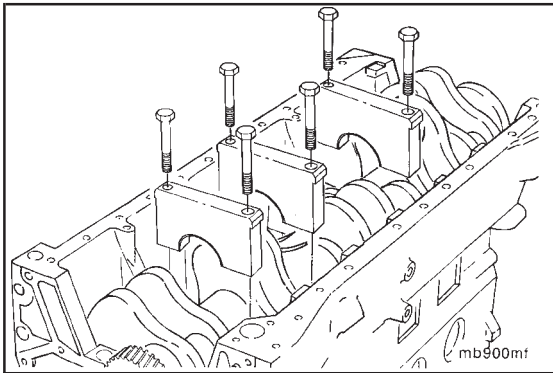

### Balancer - Installation (0-79)

23 mm

Rotate the cylinder block on the relaxed stand until the crankshaft is positioned at the top and parallel to the floor.

The number 1 and number 4 main bearing capscrews **must** be removed to install the balancer.

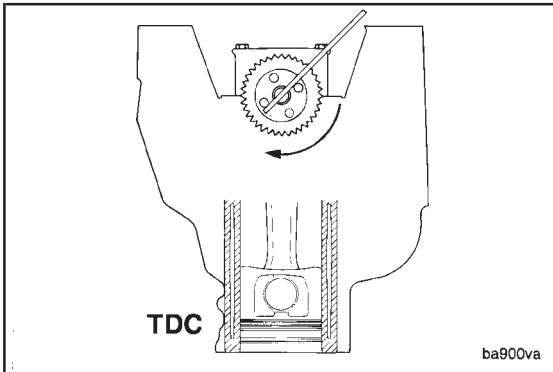

Rotate the crankshaft until No. 1 piston is at Top Dead Center. The engine **must** have a cylinder at TDC for correct gear teeth alignment when the balancer is installed.

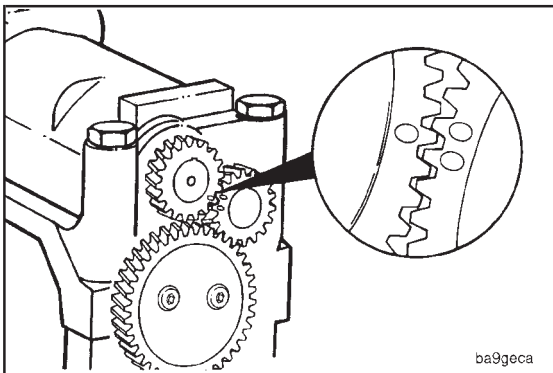

Rotate the balancer gears until the timing marks are aligned. The balancer **must** be kept in this position for correct installation on the engine.

**13 mm**

If the balancer shaft has a tapped hole, the shaft can be locked in position by temporarily installing a M8 capscrew through the housing and into the shaft.

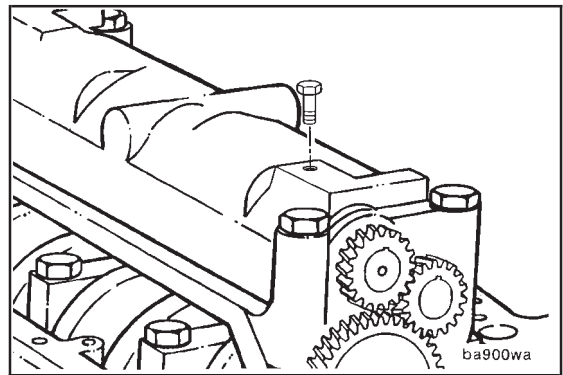

**4.5 mm Allen, 1 inch Wide Masking Tape**

**Caution:** Make sure the idler gear retainer capscrews are loose.

Follow this procedure if the shaft does not have a tapped hole.

Wrap the 4.5mm allen wrench with masking tape until it has a snug fit in the hole in the balancer housing.

A = Approximately 10mm [0.4 inch]

B = 10mm [0.4 inch]

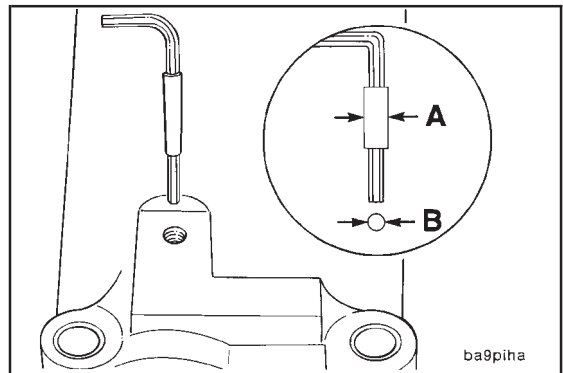

Position the locked balancer assembly onto the main bearing caps. The assembly must be located squarely with the alignment ears against the side of the caps.

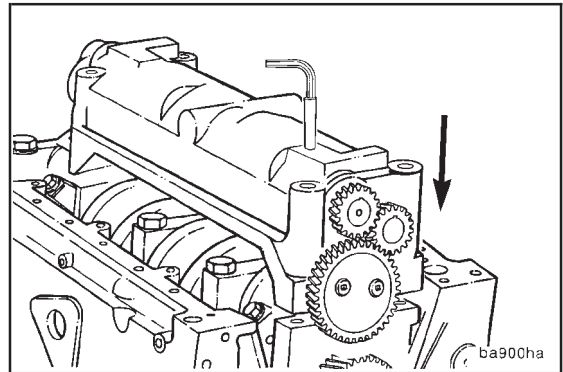

Align the slot in the idler gear retainer with the locating pin in the main bearing cap. Slide the balancer into position.

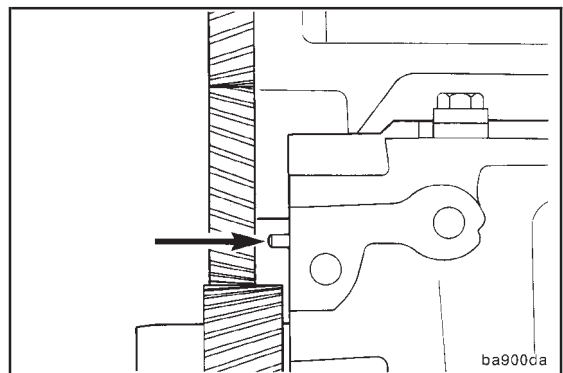

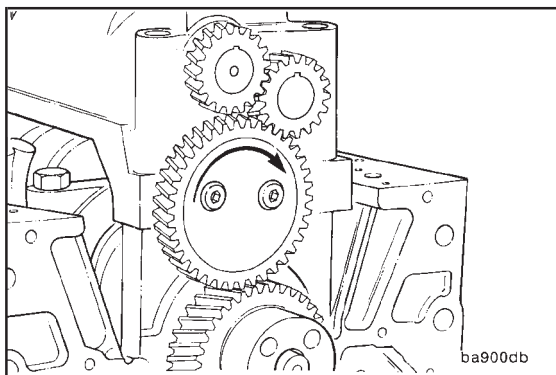

The idler gear can be slightly rotated to help in alignment.

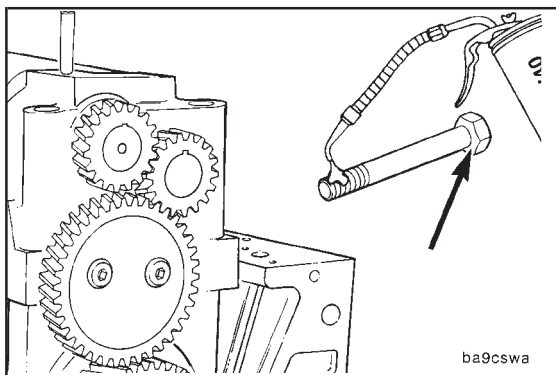

Lubricate the main bearing cap screw threads and the underside of the cap screw heads with clean engine oil.

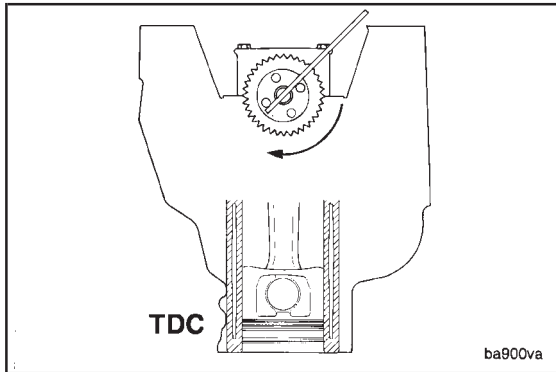

If the cap screws do not install freely, check to be sure the engine has a piston at TDC.

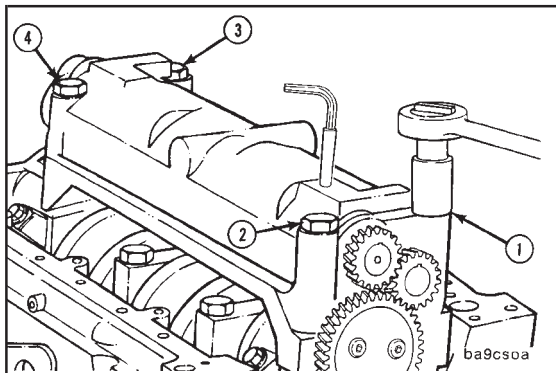

23 mm



Tighten the cap screws evenly and follow the illustrated sequence.

Step	Torque Value
1	60 N•m [ 44 ft-lb]
2	119 N•m [ 88 ft-lb]
3	176 N•m [130 ft-lb]

Remove the locking capscrew or allen wrench from the balancer.

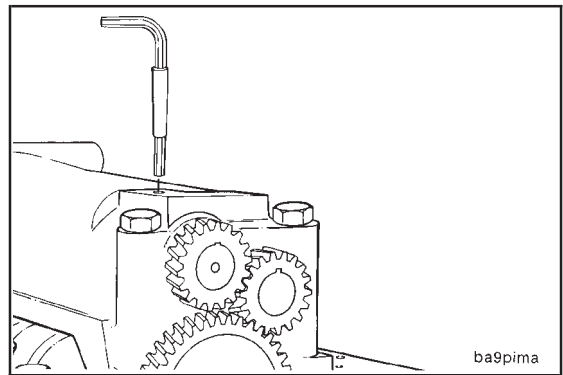

ba9pima

**8 mm Allen**

**Tighten the idler gear retainer capscrews.**

**Torque Value:** 57 N•m [42 ft-lb]

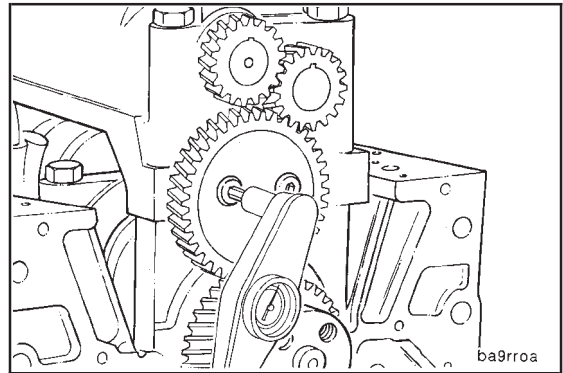

ba9rroa

Measure the idler gear backlash.

Backlash		
mm		in
0.088	MIN	[0.003]
0.420	MAX	[0.017]

If the idler gear does not meet the specifications, loosen the idler gear retainer capscrews. Reposition the idler gear and tighten the capscrews.

**Torque Value:** 57 N•m [42 ft-lb]

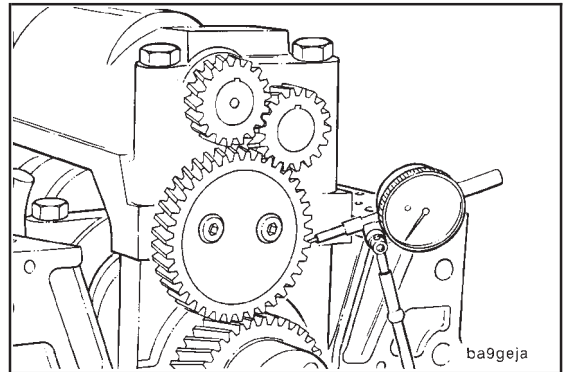

ba9geja

**The Crankshaft Must Rotate Freely**

If the crankshaft does not rotate freely, make sure the balancer does not have an interference.

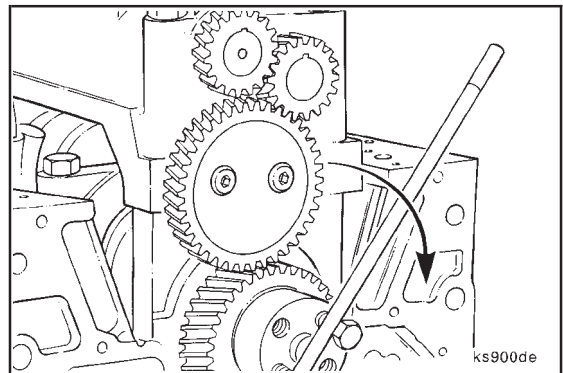

ks900de

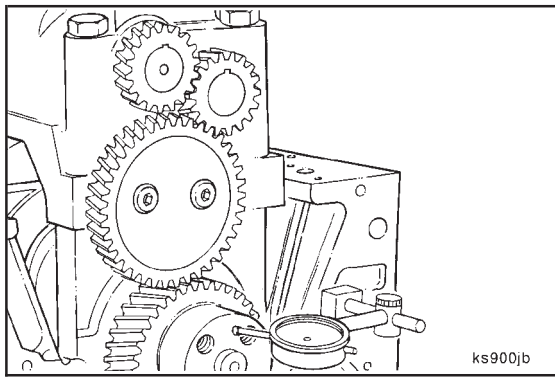

### Crankshaft End Play - Measuring (0-80)

Use a dial indicator to measure the crankshaft end play.

Crankshaft End Play Limits		
mm		in
0.102	MIN	0.004
0.432	MAX	0.017

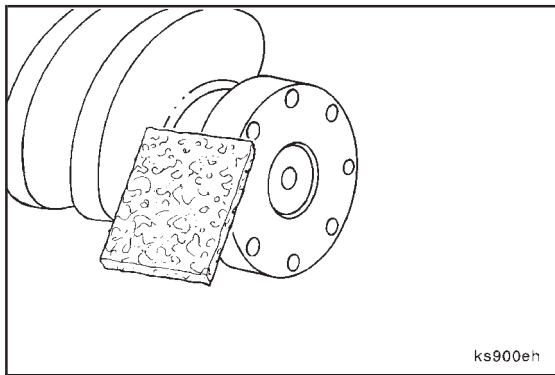

### Rear Seal - Installation (0-81)

Inspect the crankshaft flange and rear cover for dirt and damage. Use a cleaning pad, Part No. 3823258, to remove dirt or rust deposits. Wipe the crankshaft flange dry.

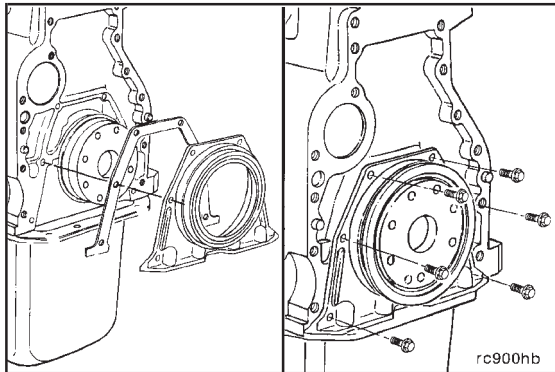

Install the rear cover and gasket. Do not tighten the cap screws to the correct torque value at this time.

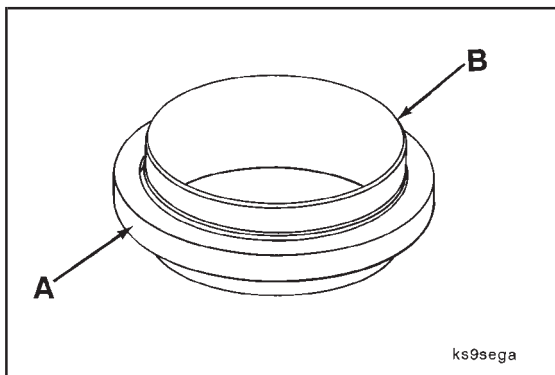

The replacement rear seal has a pilot tool installed. Do not remove the pilot tool at this time.

Apply a mild soap to the rubber outside diameter of the oil seal.

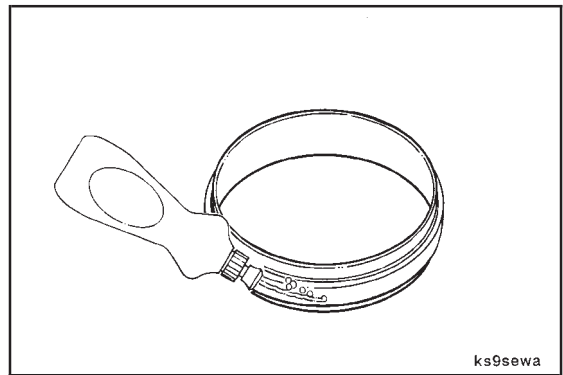

Use the alignment and installation tool packaged in the seal kit. Drive the seal into the housing until the driver bottoms.



**NOTE:** Alternately, drive the seal at the 12, 3, 6 and 9 o'clock positions to install the seal square to the crankshaft flange.

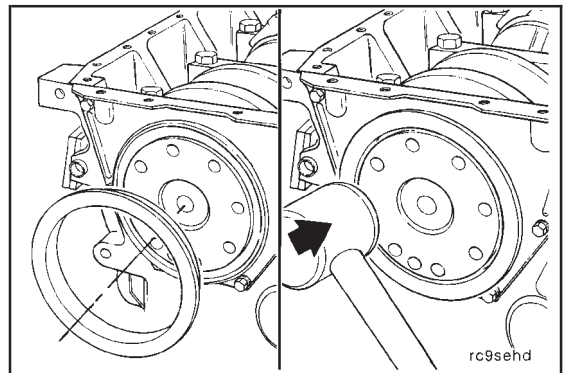

Make sure the seal housing is level with both sides of the cylinder block oil pan rail. Tighten the rear cover capscrews.

**Torque Value:** 7 N•m [80 in-lb]

Remove the seal pilot tool. Trim the gaskets even with the oil pan mounting surface.

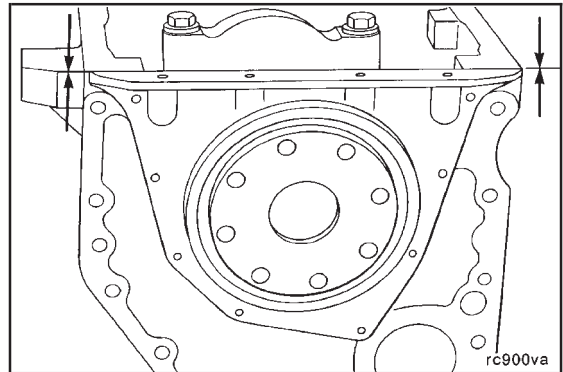

### Suction Tube - Installation (0-82)

Position the suction tube and gasket on the cylinder block.

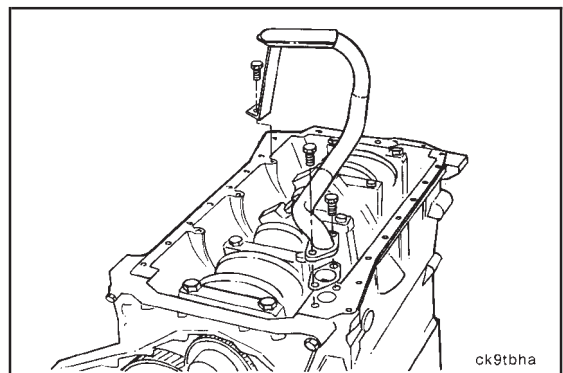

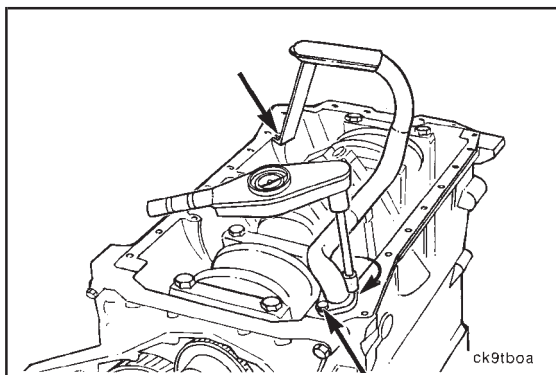

10 mm, 13 mm

Tighten the oil suction tube and brace capscrews.



Torque Value: 24 N•m [18 ft-lb]

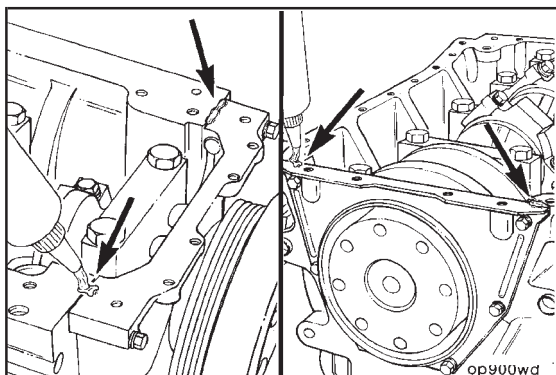

### Oil Pan - Installation (0-83)

#### Oil Pan Sealing Surfaces - Sealants



Use Three Bond 1207-C® to fill the joints between the pan rail, gear housing and rear cover.

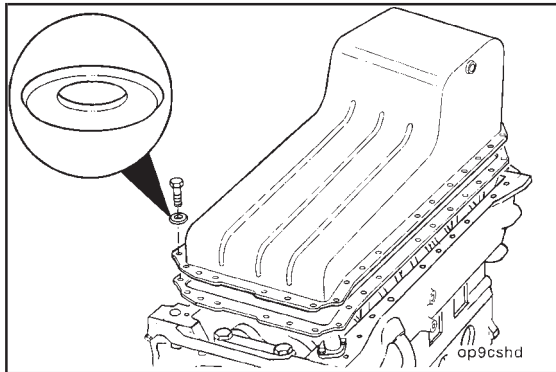

10 mm

Assemble the oil pan and capscrews as illustrated.



Torque Value: 24 N•m [18 ft-lb]

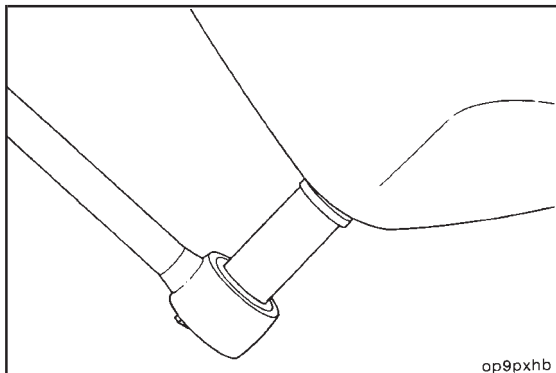

17 mm

Install the drain plug and a new sealing washer.



Torque Value: 80 N•m [59 ft-lb]



### Oil Cooler - Installation (0-84)

**Caution:** If a new element is to be installed, be sure to remove the shipping plugs.

Insert two capscrews through the oil cooler cover. Package the cooler cover gasket, oil cooler, oil cooler gasket and oil cooler cover.

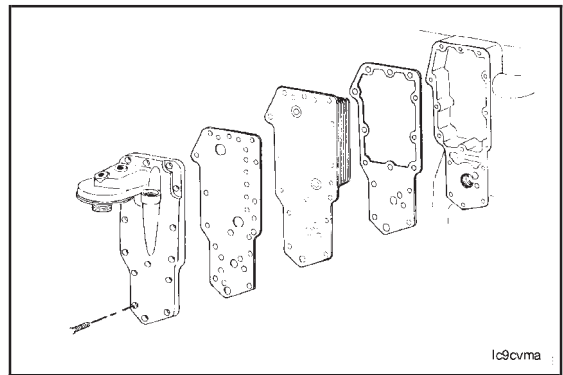

**10 mm**

Install the “package” on the cylinder block.

**Torque Value:** 24 N•m [18 ft-lb]

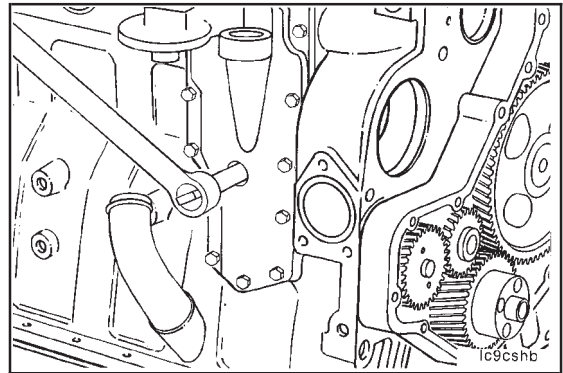

### Side Oil Fill - Installation (0-85)

**15 mm**

If the engine is so equipped, install the side oil fill assembly and o-ring.

**Torque Value:** 43 N•m [32 ft-lb]

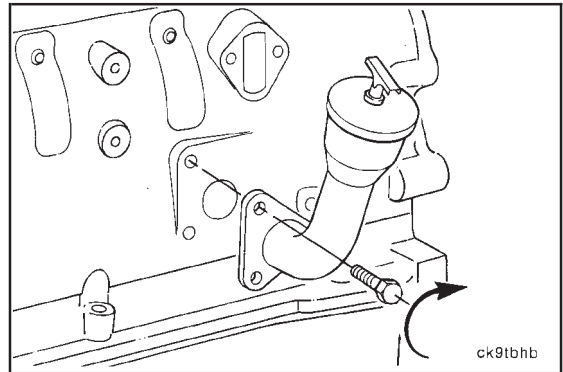

### Fuel Transfer Pump - Installation (0-86)

**Caution:** When installing piston style transfer pumps, alternately tighten the mounting capscrews. As the capscrews are tightened, the transfer pump plunger is pushed into the pump. Failure to tighten the capscrews in an even manner can result in the plunger being bent or broken.

Install the fuel transfer pump, gaskets and spacer if using a piston style pump.

**Torque Value:** 24 N•m [18 ft-lb]

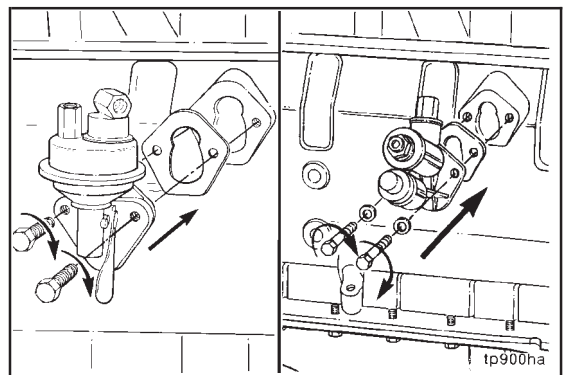



### Tappet Cover - Installation (0-87)



Install the tappet cover gasket.

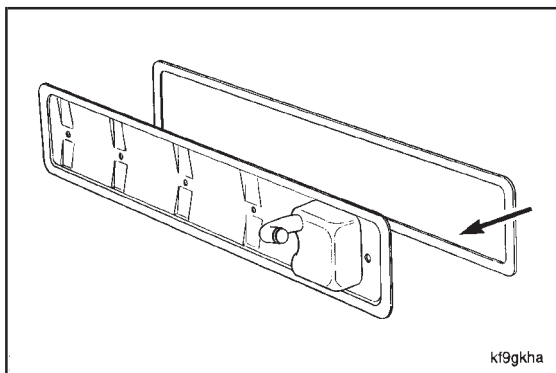

The tappet cover gasket must be installed on the cover as shown in the illustration.

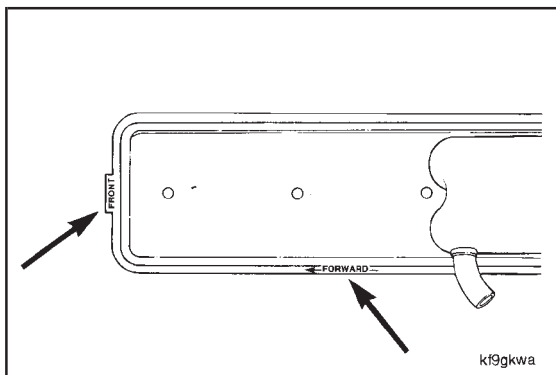

Install the tappet cover and baffle with the illustrated mounting capscrews and rubber seals. The remaining capscrews and rubber seals will be installed later with the fuel drain line.



10 mm



Torque Value: 24 N•m [18 ft-lb]

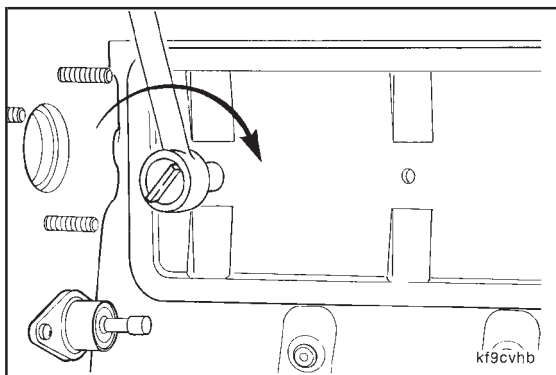

### Injection Pump - Installation (0-88)

Install the injection pump gasket. The Nippondenso EP9 and the Bosch P7100 injection pump use a sealing o-ring instead of a sealing gasket. Make sure the o-ring is positioned properly and not damaged. Lubricate with clean engine oil.

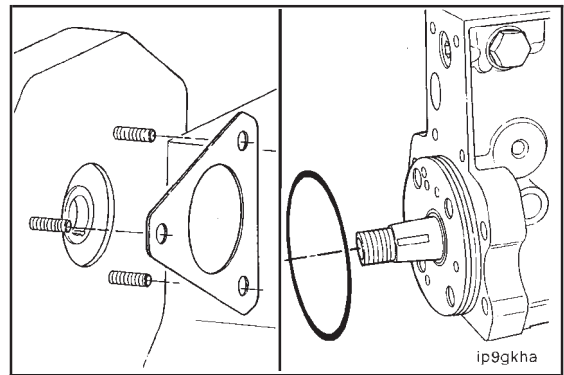

Install the key in the keyway of the Bosch and CAV injection pump shafts. The Nippondenso EP9 and the Bosch P7100 pumps do not require a key.

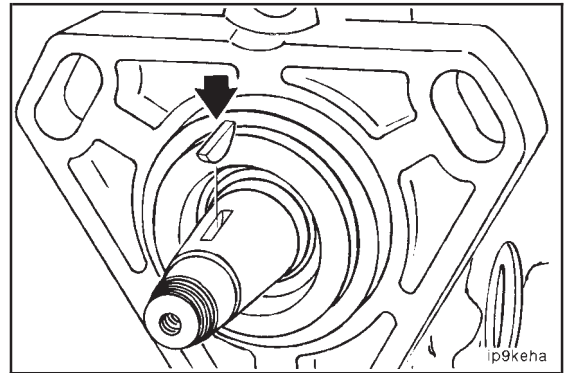

Service Tip: To prevent the key from falling out of the keyway in the shaft, use a small punch to swell one side of the key. When adequately expanded, it should require a hammer to lightly tap the key into position in the keyway.

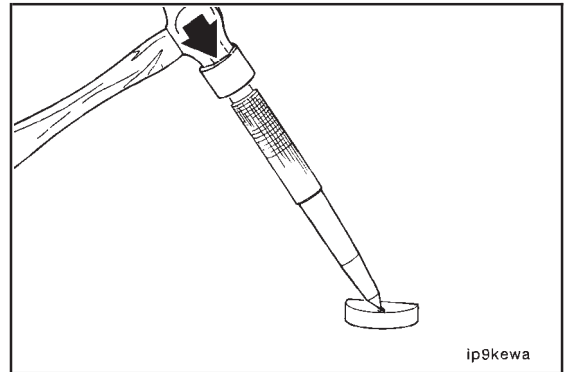

Locate top dead center (TDC) for Cylinder Number 1 by barring the engine while pushing in on the engine timing pin until it engages.

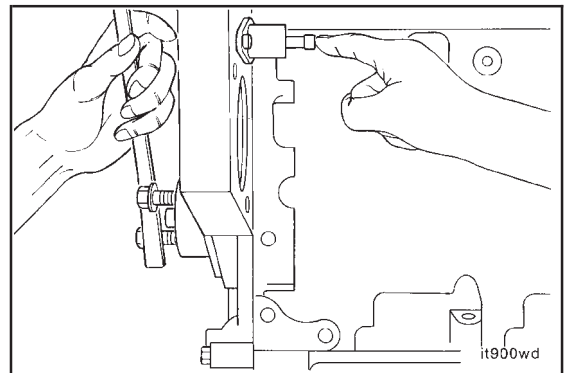

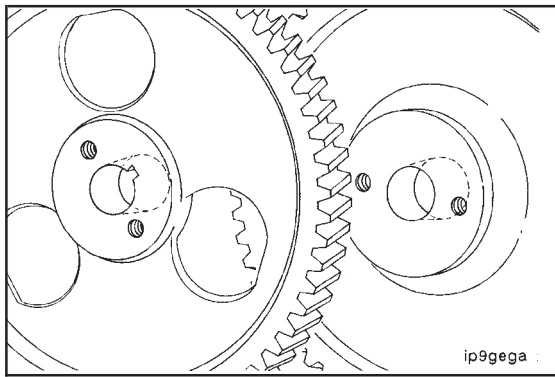

The injection pump drive gear has a tapered bore. Orient the wide end of the taper toward the engine (timing marks away). The drive gear for the Nippondenso EP9 and the Bosch P7100 pump does not have timing marks and must be positioned using the tapered bore as a reference.

Letter on Pump Gear	Engine Model	Injection Pump	Certification
A	4B3.9, 4BT3.9	Stanadyne	Non-Certified
A	4B3.9, 4BT3.9, 4BTA3.9	Lucas CAV DPA Pump	All Non-Certified
B	4B3.9, 4BTA3.9	Robert Bosch VE Pump	86.87 EPA All pre-86 All Non-Certified
C	6BT5.9, 6BTA5.9	Robert Bosch VE Pump	86.87 EPA All pre-86 All Non-Certified CPL 600
D	6B5.9, 6BT5.9	Stanadyne	Non-Certified
D	6B5.9, 6BT5.9, 6BTA5.9	Lucas CAV DPA Pump	All Non-Certified
E	6BT5.9, 6BTA5.9	Robert Bosch VE Pump	86,87,88,89,90,91,92 CARB 88,89,90,91,92 EPA
F	4BT3.9, 4BTA3.9	Robert Bosch VE Pump	86,87,88,89,90,91,92 CARB 88,89,90,91,92 EPA
G	6BTA5.9	Lucas CAV DPA	All Fire Pump CPL 1165
H	Not Used at This Time		

it900ga

This table **must** be used to make sure of proper fuel injection pump-to-engine timing. The critical parts list (CPL) number from the engine data plate and the Control Parts List Manual (Bulletin No. 3379133-20) **must** be used to determine whether or not the engine is certified, and if so, what year and regulating agency (EPA or CARB).

Given this information, use the table to determine which letter on the fuel injection pump drive gear is aligned with the camshaft gear.

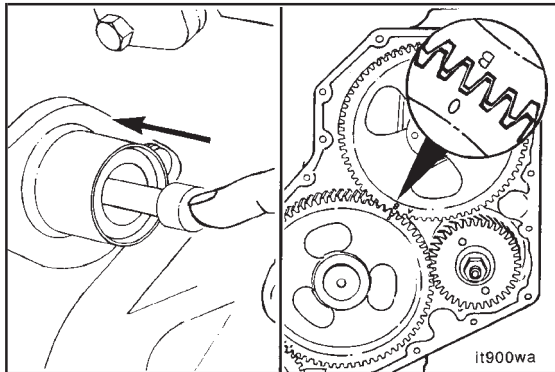

Align the timing marks and set the gear into the housing. No timing mark alignment is required for the Nippondenso EP9, or Bosch Inline fuel pumps.

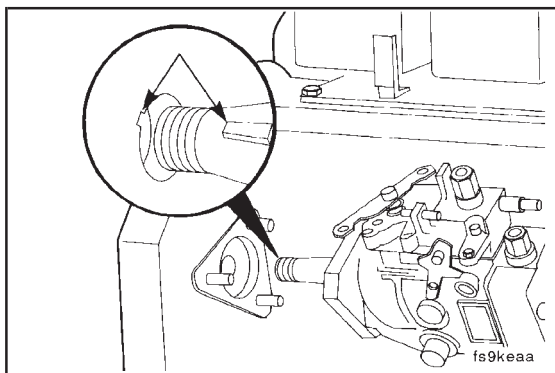

**Locked Timed Injection Pump - Installation (0-89)**

Install the pump. Make sure the key doesn't fall into the gear housing.

**NOTE:** The keyway in the shaft of new and reconditioned pumps will be locked in a position corresponding to the keyway in the drive gear when cylinder number 1 is at TDC.

If the Bosch, Stanadyne or CAV pump was not locked in this position before removal and a timing tool, Part No. 3377259, is not available for the Bosch pump, refer to installing an unlocked pump, procedures (0-91 and 0-92). Refer to Section 5 for the Nippondenso EP9 and Bosch inline timing procedure.

Attach the pump by finger tightening the mounting nuts. The pump must be free to move.

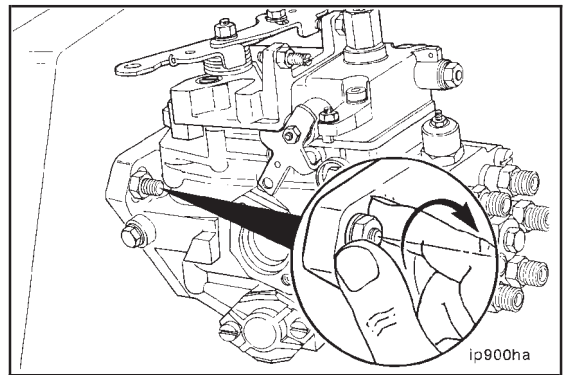

**22 mm**

Install the drive gear mounting nut and spring washer. The pump can rotate slightly due to gear helix and clearance. This is acceptable **providing** the pump is free to move on the flange slots and the crankshaft **does not** move.

**Torque Value:** 15 N•m [11 ft-lb]

**This is not the final torque. The drive shaft nut will be torqued to the final specification after the pump is unlocked.**

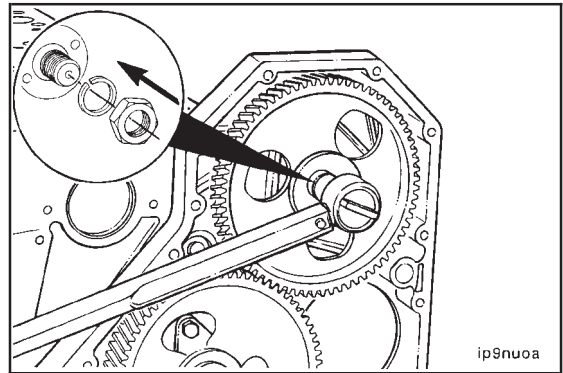

**13 mm or 15 mm**

Rotate the pump to align the scribe marks and tighten the mounting nuts. The Nippondenso EP9 and Bosch inline do not have alignment marks.

	<b>Torque Value</b>
Nippondenso EP9	43 N•m [32 ft-lb]
Bosch P7100	43 N•m [32 ft-lb]
Lucas CAV, Stanadyne, Bosch VE	30 N•m [22 ft-lb]

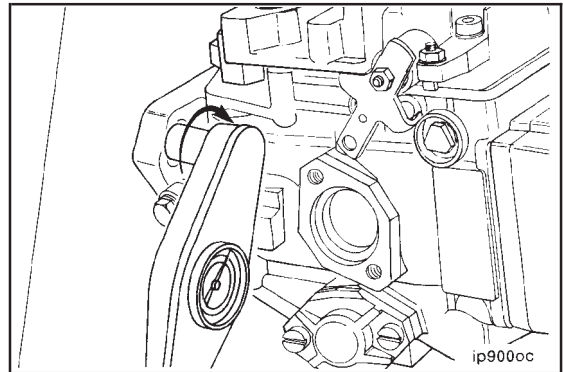

If a new or rebuilt Stanadyne, Bosch or CAV pump without scribe marks is being installed, take up the gear lash by rotating the pump against the direction of drive rotation.

Make sure the engine is at TDC.

Tighten the pump retaining nuts.

**Torque Value:** 24 N•m [18 ft-lb]

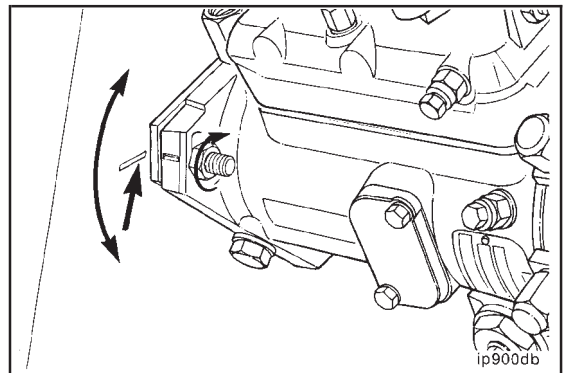

**Injection Pumps - Unlocking (0-90)**

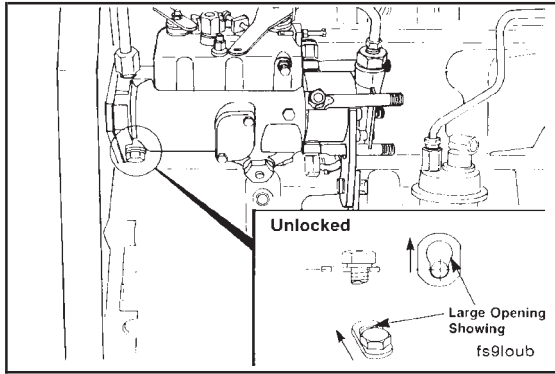

**14 mm**

Loosen the Stanadyne and CAV pump lockscrew and position the special washer with the large opening showing behind the lockscrew head.



**Torque Value:** 20 N•m [15 ft-lb] (CAV)  
12 N•m [9 ft-lb] (Stanadyne)

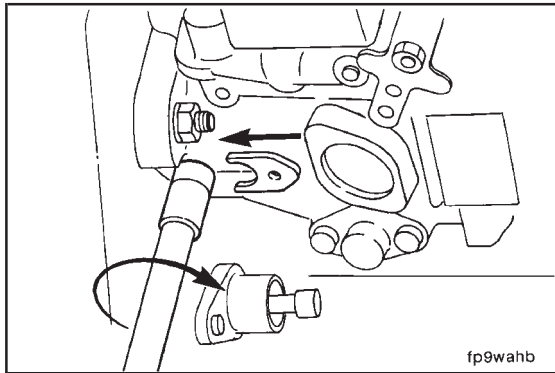

**8 mm Allen or 10 mm Hex**

The special washer for the Bosch pump is wired to the pump and must be installed under the lockscrew.



Tighten the pump lockscrew.

**Torque Value:** 13 N•m [10 ft-lb]

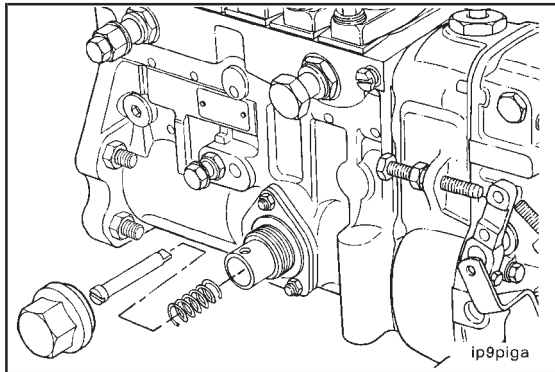

**34 mm**

The Nippondenso EP9 has a plastic timing pin and spring which is located under the cap on the outboard side of the pump. This pin locates the pump shaft to correspond with TDC for number one cylinder. To unlock the pump, the spring is placed **under** the head of the timing pin and the cap installed.



**Torque Value:** 70 N•m [50 ft-lb]

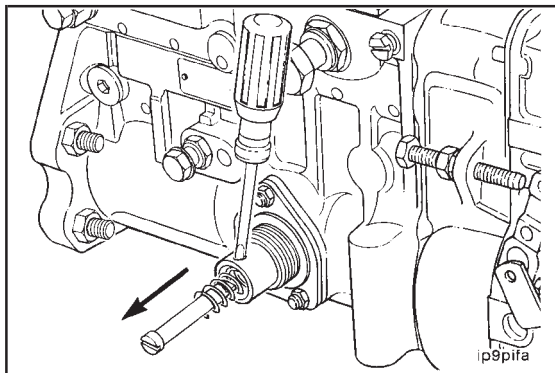

**Service Tip:** If difficulty is experienced with disengaging the plastic timing pin, use a small flat blade screwdriver to pry the pin free.

The Bosch P7100 has a timing pin located under a cap on the outboard side of the governor. To unlock the pump the position of the pin is reversed under the cap.

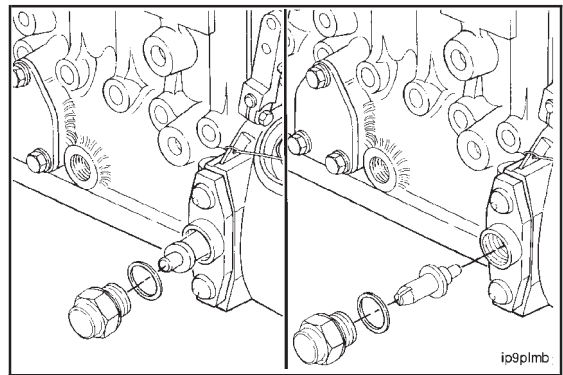

Disengage the timing pin.

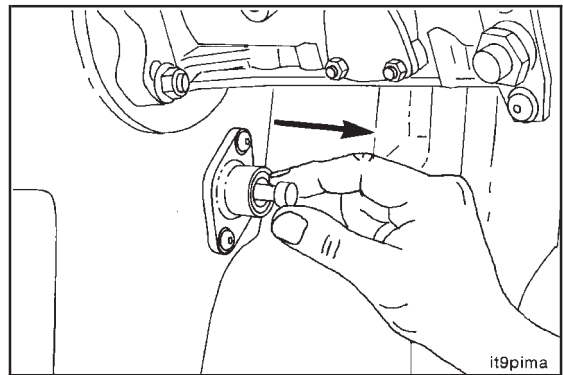

**22 mm or 27 mm**

Tighten the drive gear mounting nut.

Torque Value	
Stanadyne, Bosch and CAV (Rotary)	65 N•m [ 48 ft-lb]
Nippondenso EP9	123 N•m [91 ft-lb]
Bosch P7100	165 N•m [122 ft-lb]

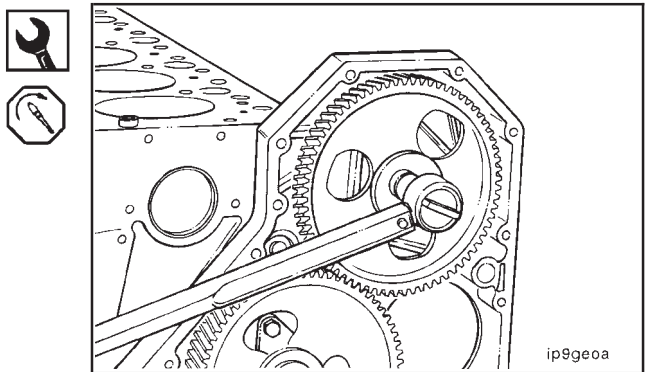

**Chisel, Hammer**

If a rebuilt pump is being installed, permanently mark the injection pump flange to match the mark on the gear housing. The Nippondenso EP9 and Bosch P7100 do not require timing marks.

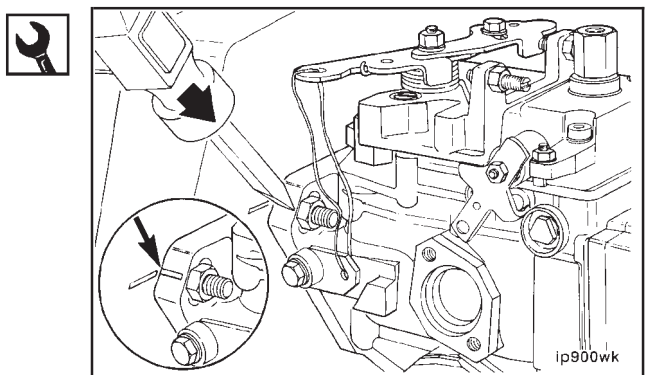

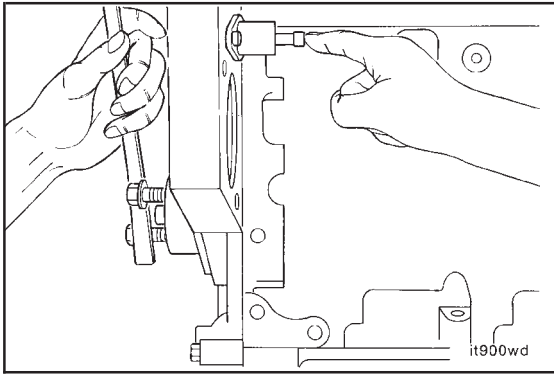

**Unlocked CAV Injection Pump - Installation (0-91)**

Locate Top Dead Center (TDC) for Cylinder Number 1 by barring the engine while pushing in on the timing pin until it engages.

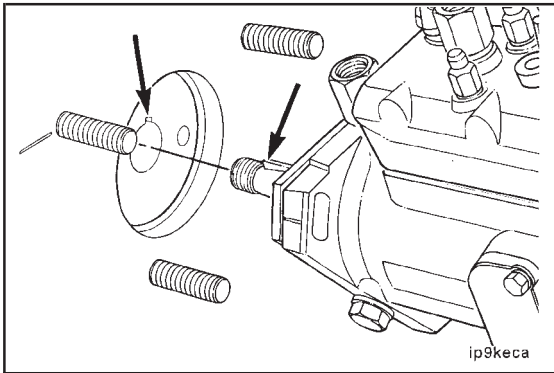

If the shaft of a Lucas CAV pump was not locked with the engine at TDC, rotate the pump shaft to align the key and the keyway in the gear.



Secure the pump by finger tightening the three mounting nuts.

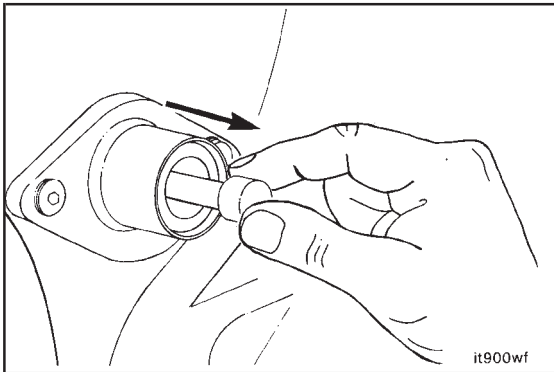

Disengage the TDC pin.

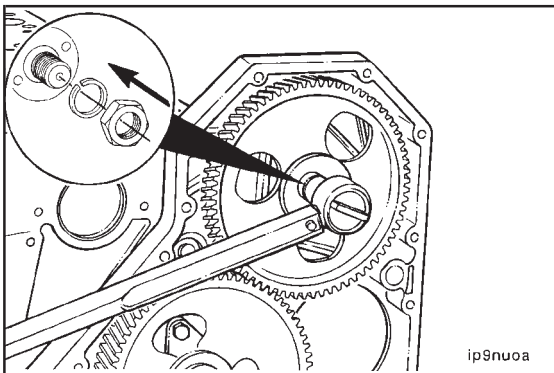

**22 mm**

Secure the drive gear with the mounting nut and lock washer.



**Torque Value:** 65 N•m [48 ft-lb]

**13 mm**

Rotate the pump to align the scribe marks on the pump and gear housing.

**Torque Value:** 30 N•m [22 ft-lb]

**NOTE:** If no timing marks exist, refer to Bulletin Nos. 3810348-01 or 3810486.

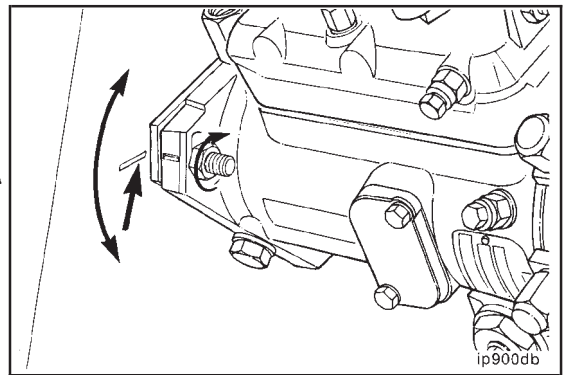

**Unlocked Stanadyne DB4 Injection Pump - Installation (0-92)**

Locate top dead center (TDC) for cylinder number 1 by rotating the crankshaft while pushing in on the timing pin until it engages.

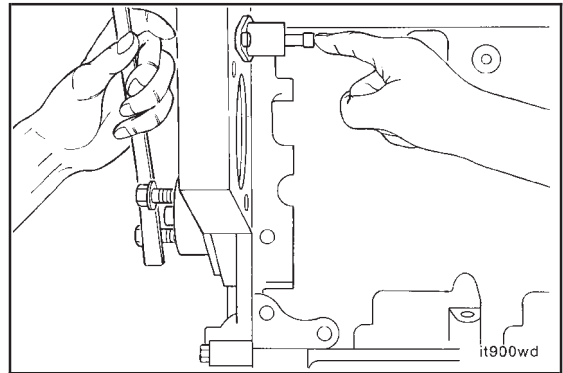

Rotate the fuel injection pump drive shaft in the direction of pump rotation to align the timing line on the weight retainer hub with the line on the cam ring.

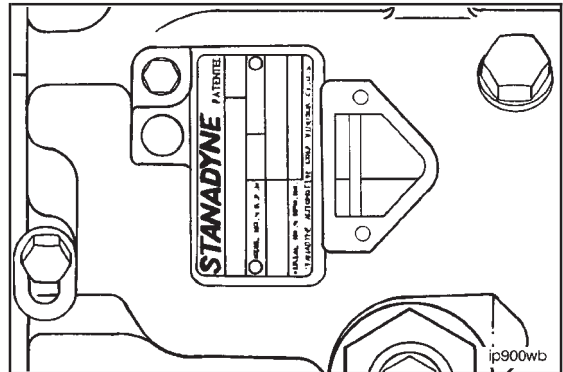

Position the fuel injection drive shaft locking key plate in the locked position. Turn the locking screw in until contact is made with the drive shaft.

**Torque Value:** 12 N•m [106 in-lb]

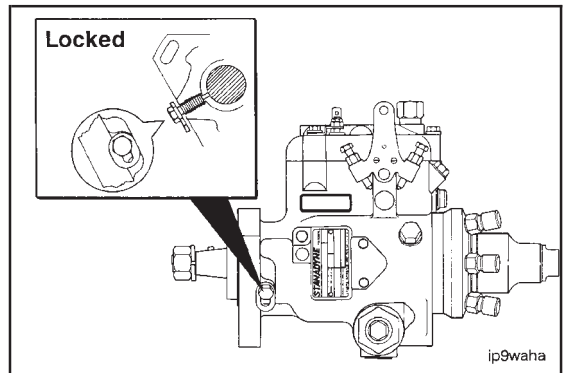



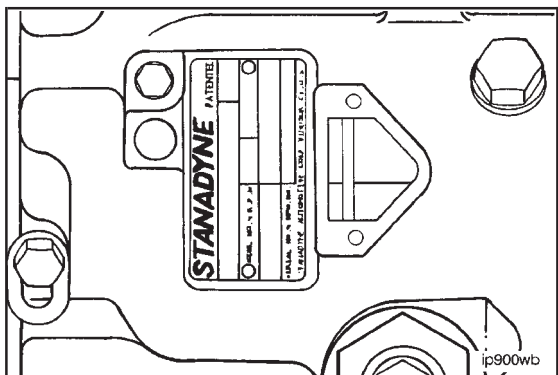

Verify the timing marks are aligned after lock timed.

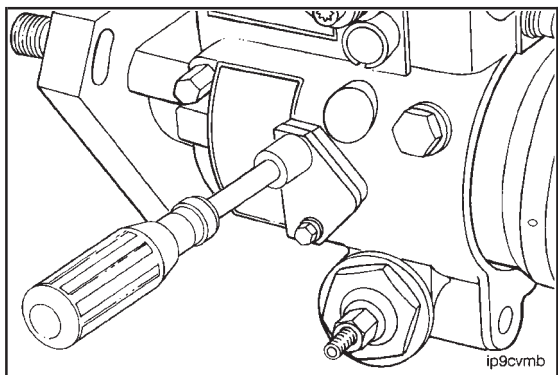

Install the fuel injection pump timing cover.

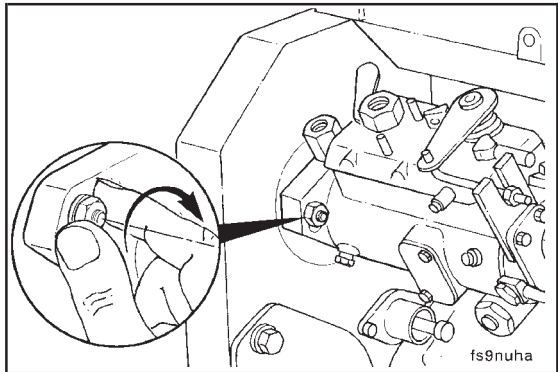

Secure the pump by finger tightening the mounting nuts.

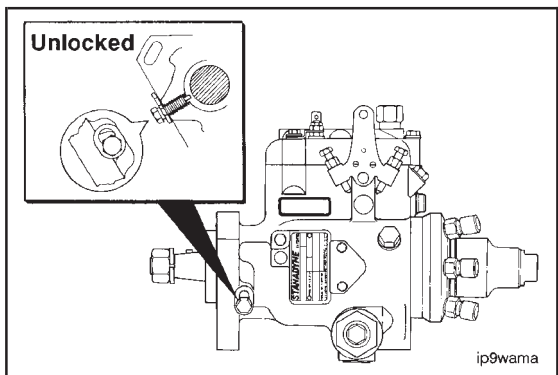

**3/8 Inch**

Loosen the Stanadyne DB4 fuel injection pump lock screw and position the special washer behind the lock screw head.



Tighten the lock screw.

**22 mm**

Secure the drive gear with the mounting nut and washer.

**NOTE:** This is not the final torque value.

**Torque Value:** 15 N•m [11 ft-lb]

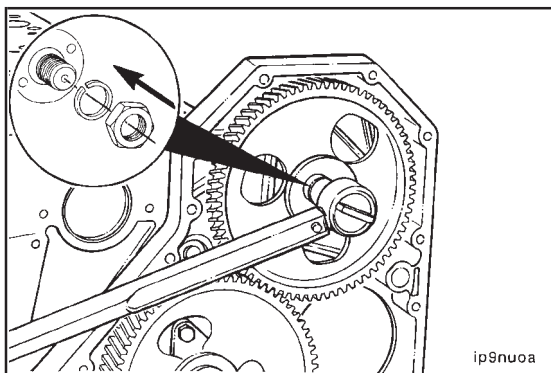

Disengage the timing pin.

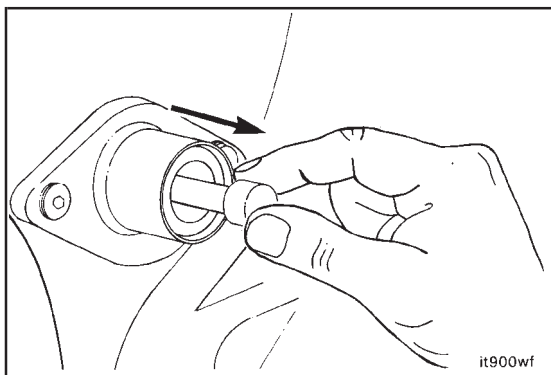

**22 mm**

Tighten the drive gear mounting nut.

**Torque Value:** 65 N•m [48 ft-lb]

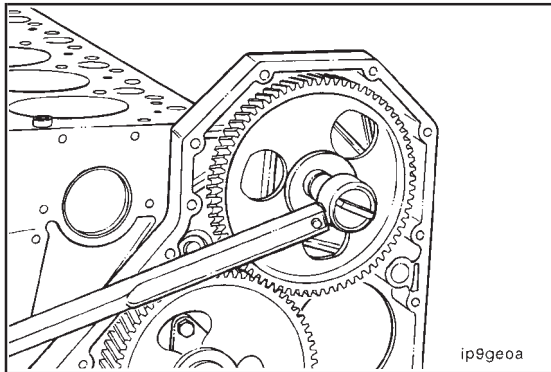

**13 mm**

Rotate the pump to align the scribe marks on the pump and housing.

Tighten the mounting nuts.

**Torque Value:** 30 N•m [22 ft-lb]

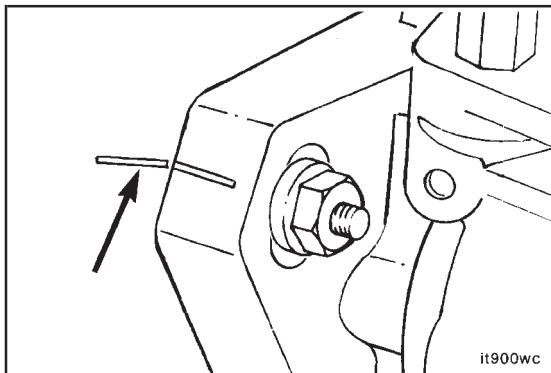

**Unlocked Bosch VE and P7100 Injection Pump - Installation (0-93)**

**VE Installation**

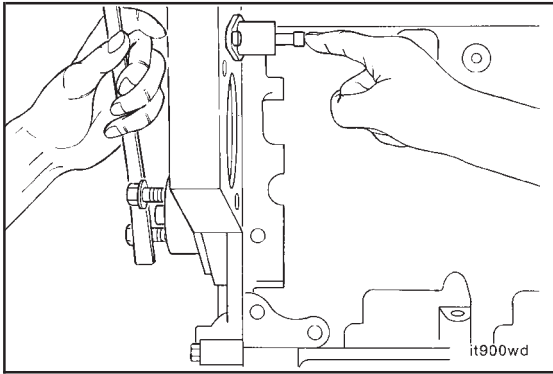

The following procedure was written for those without immediate access to a fuel pump timing tool, Part No. 3377259. The procedure for timing an unlocked Bosch VE fuel pump with the pump off of the engine is given in Section 5. **If the pump is installed using the following procedure, it should be adjusted to the exact timing using tool No. 3377259 before being put into service.** This procedure is available in Bulletin Nos. 3810348-01 and 3810486.

Locate top dead center (TDC) for Cylinder Number 1 by rotating the crankshaft while pushing in on the timing pin until it engages.

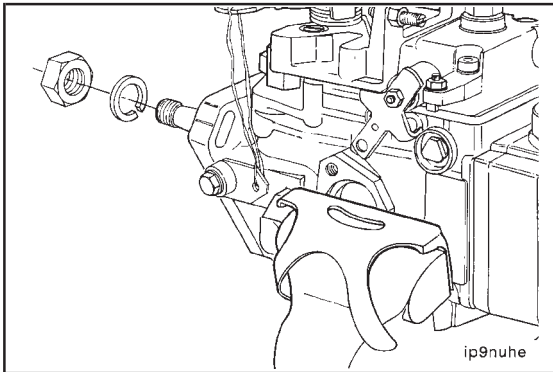

The Robert Bosch VE pump uses a spring loaded cam mechanism that makes positioning the keyway more difficult.

To align the Robert Bosch VE keyway, secure the pump in a vise and install the lock washer and nut on the drive shaft.

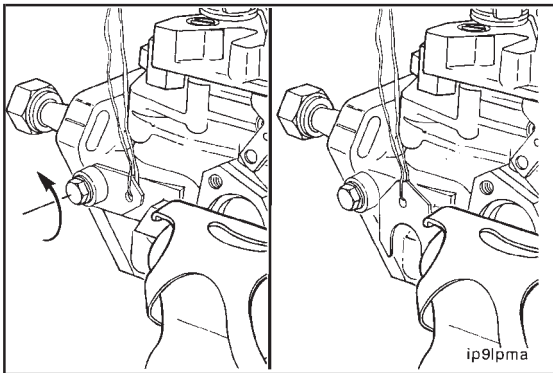

**8 mm Allen or 10 mm Hex**

Remove the special washer by loosening the lockscrew.



**22 mm; 8 mm Allen or 10 mm Hex**

Turn the shaft so the key is aligned with the hash mark on the seal housing.

Lock the pump shaft by tightening the lockscrew.

**Torque Value:** 30 N•m [22 ft-lb]

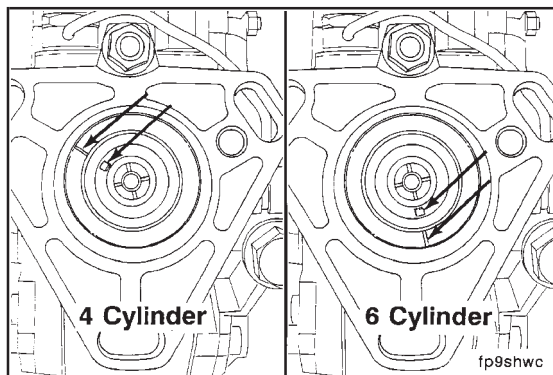

Remove the drive nut and washer from the drive shaft by striking the wrench with a sharp blow in a counterclockwise direction.

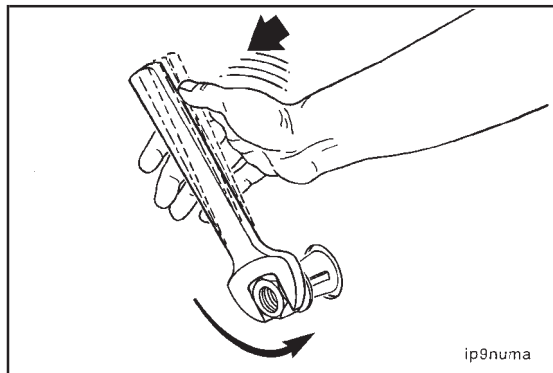

Be sure the timing pin is disengaged.

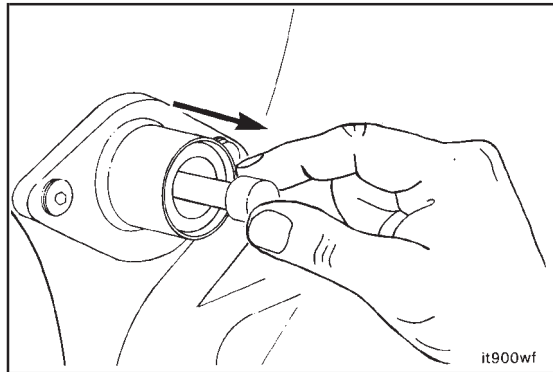

**Caution:** Make sure the key does not fall into the gear housing.

Install the pump.

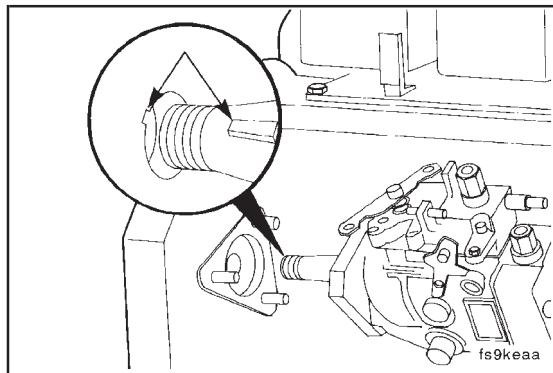

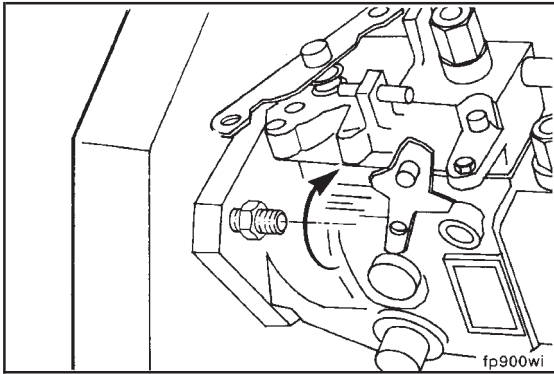

Secure the pump by finger tightening the three mounting nuts. The pump must be free to move in the slots.

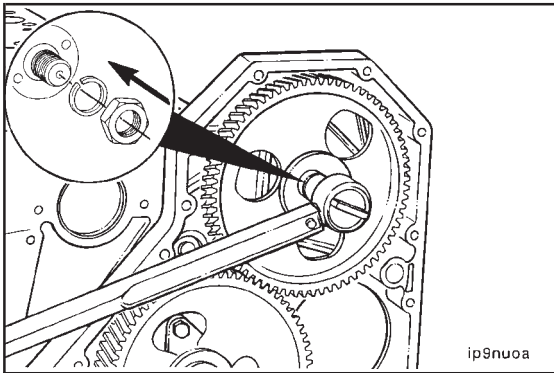

**22 mm**

Install the drive gear mounting nut and lock washer on the pump drive shaft.

**Torque Value:** 15 N•m [11 ft-lb]

**NOTE:** This is not the final torque value. The drive shaft nut will be torqued to the final specification after the pump is unlocked.

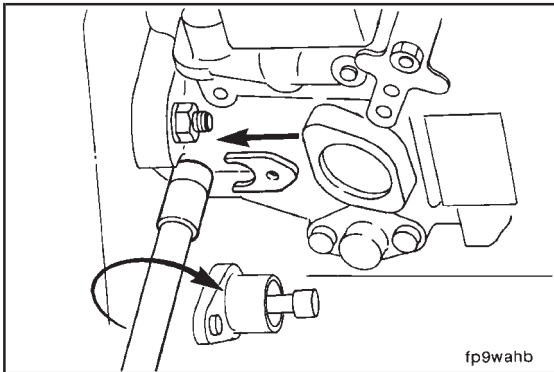

**8 mm Allen or 10 mm Hex**

Loosen the Bosch pump lockscrew and position the special washer behind the lockscrew head.

Tighten the lockscrew in the **unlocked** position.

**Torque Value:** 13 N•m [10 ft-lb]

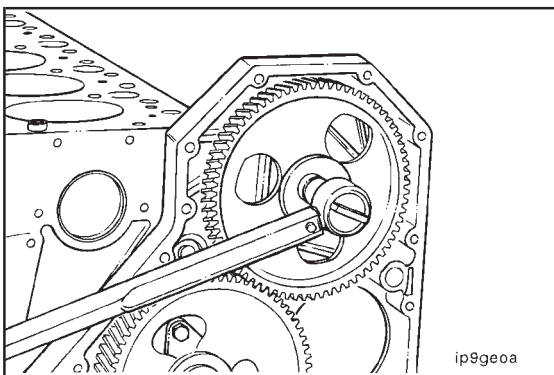

**22 mm**

Tighten the drive gear mounting nut.

**Torque Value:** 65 N•m [48 ft-lb]

**13 mm**

Rotate the pump to align the scribe marks on the pump and housing.

Tighten the three mounting nuts.

**Torque Value:** 24 N•m [18 ft-lb]

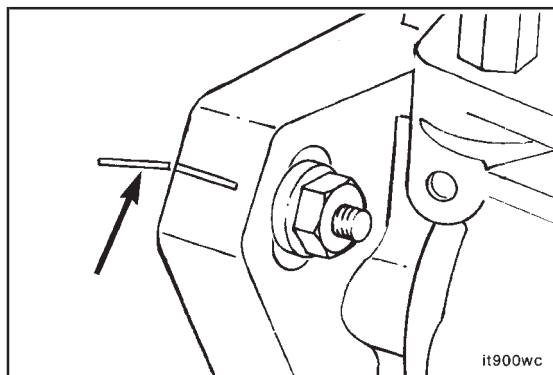

**Disengage the TDC pin.**

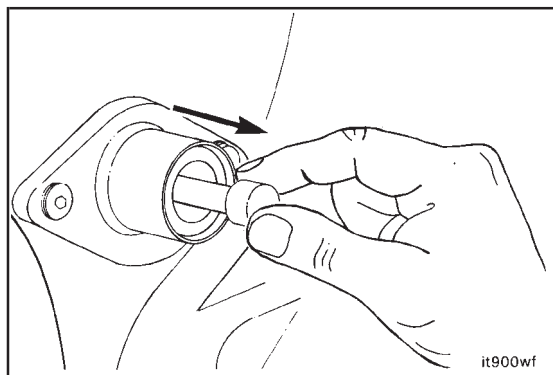

**Be sure the backlash is correct for replaced gears.**

Use a dial indicator to measure backlash.

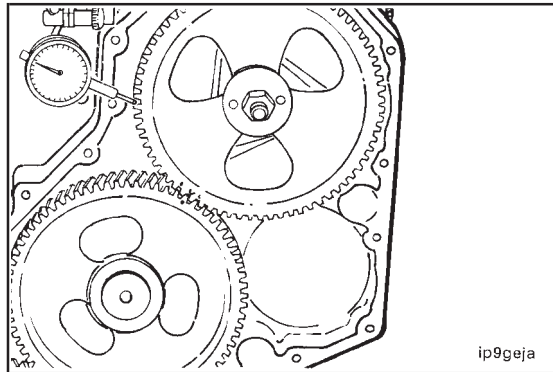

**Pump Gear Backlash Limit**

A = .076 to .330 mm [0.003 to 0.013 in]

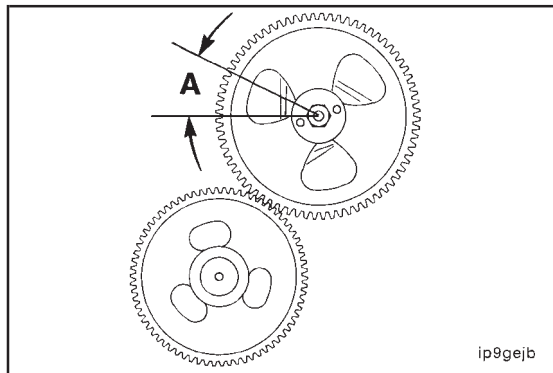

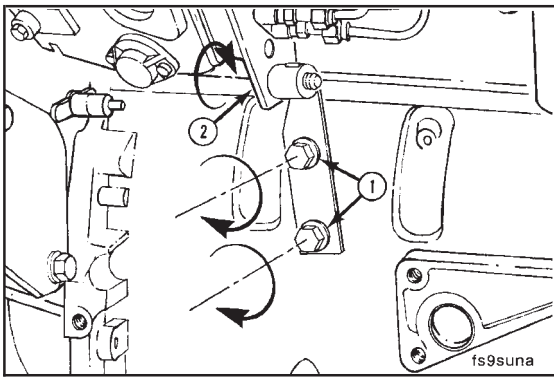

10 mm

Attach the injection pump support bracket. Finger tighten all capscrews before final tightening.



**NOTE:** Tighten the capscrews which attach the bracket to the block (1) before tightening the capscrew which secures the bracket to the pump (2).



**Torque Value:** 24 N•m [18 ft-lb]

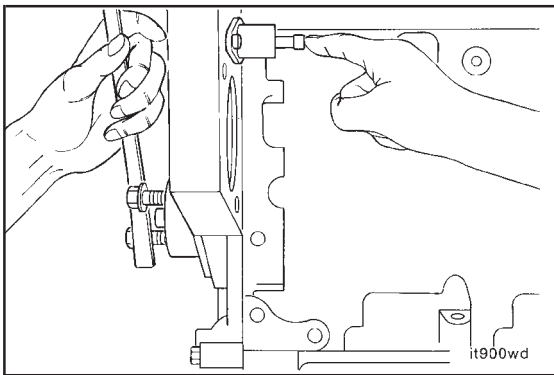

**P7100 Injection Pump Installation**

Make sure the engine has Cylinder No. 1 at TDC.

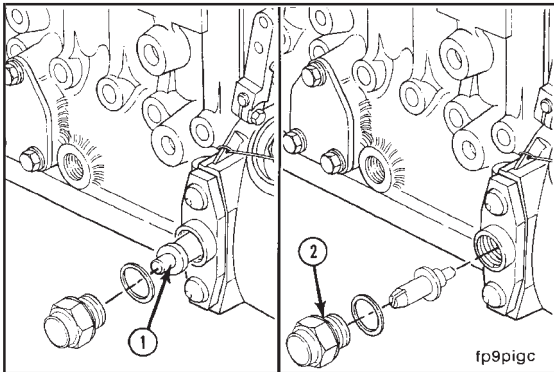

The injection pump also has a timing pin (1), located in the governor housing, to position the pump shaft to correspond with TDC for Cylinder No. 1. The pin is to be reversed and stored in the housing (2) after the pump is installed.

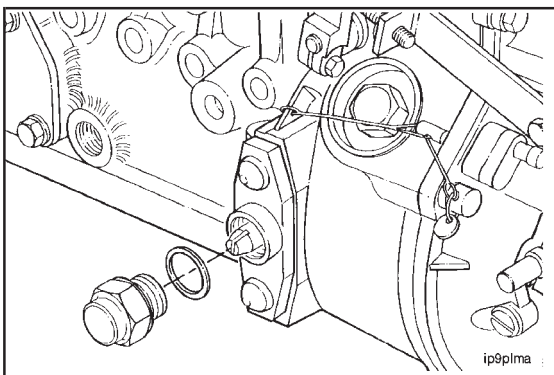

24 mm

Remove the access plug.



Remove the timing pin.

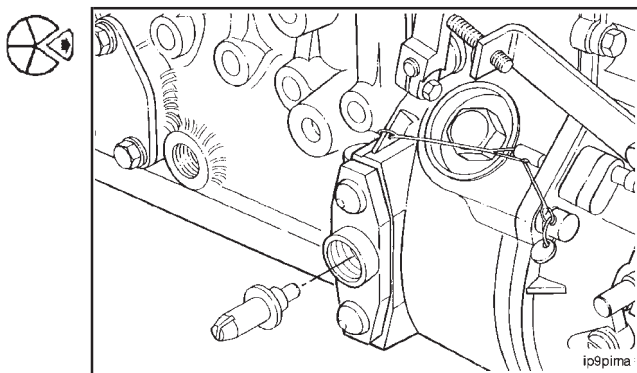

If the timing tooth is not aligned with the timing pin hole, rotate the pump shaft until the timing tooth aligns.

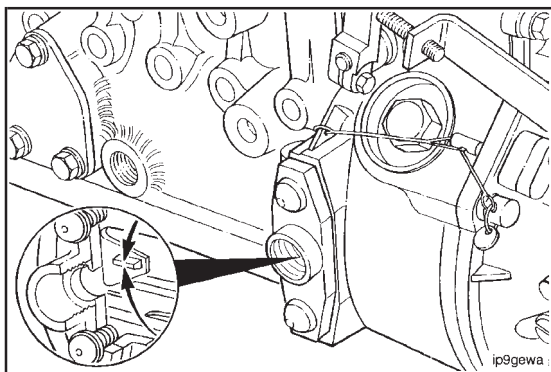

Reverse the position of the pin so the slot of the pin will fit over the timing tooth in the pump.

Install and secure the pin with the access plug.

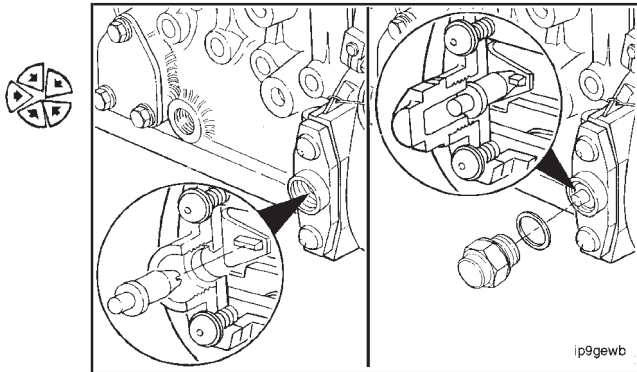

Use a 50/50 mixture of clean engine oil and STP® or equivalent to lubricate the gear cover housing to ensure the injection pump will slide into the housing easily.

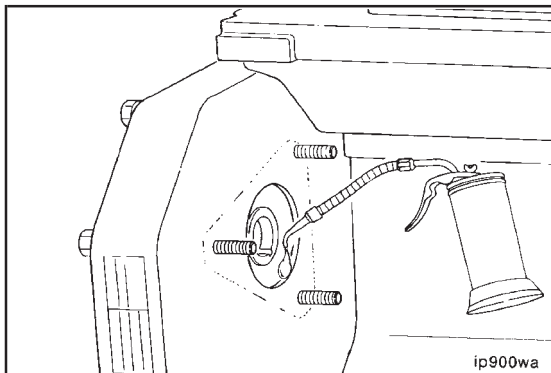



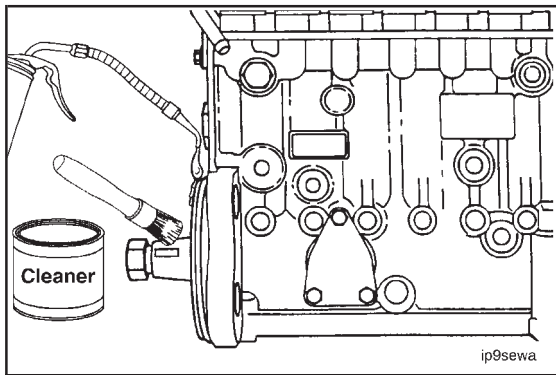

Also lubricate the mounting flange of the injection pump.

**NOTE:** The P7100 injection pump driveshaft has a provision for a Woodruff key, however, it is not required. Timing mark alignment is **not** required for the P7100 drive gear.

Make sure the fuel injection pump drive gear inside diameter and the shaft outside diameter are clean and dry before the gear is installed.

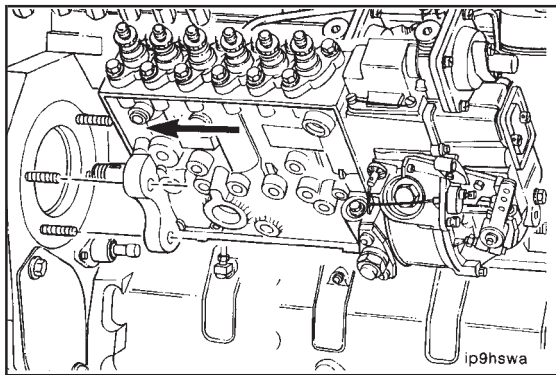

Slide the pump shaft through the drive gear and position the pump flange onto the mounting studs.

**Push the pump forward until the mounting flange and o-ring are properly fitted into the gear housing bore.**

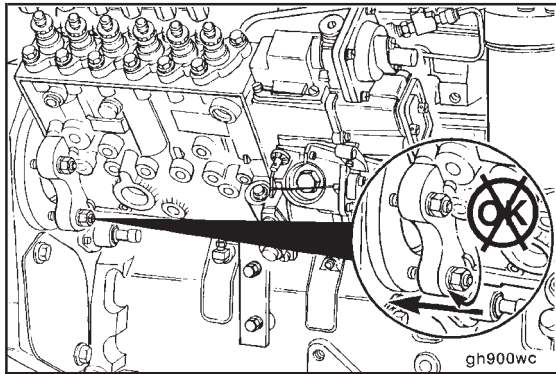

Do not attempt to pull the pump flange into the gear housing with the mounting nuts as damage to housing will occur.

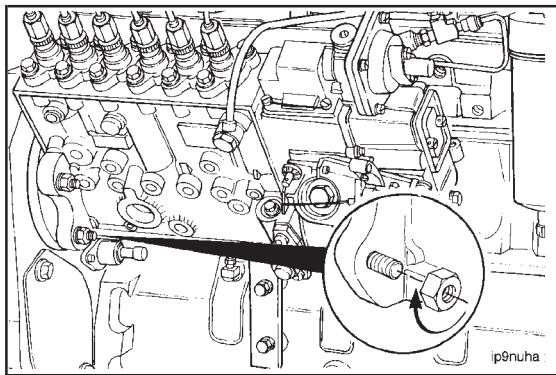

15 mm

Install the mounting nuts.



**Torque Value:** 43 N•m [32 ft-lb]



**30 mm**

Install the retaining nut and washer.

**Torque Value:** 15 N•m [11 ft-lb]

To prevent damage to the timing pins, do not exceed the torque value given. This is not the final torque value for the retaining nut.

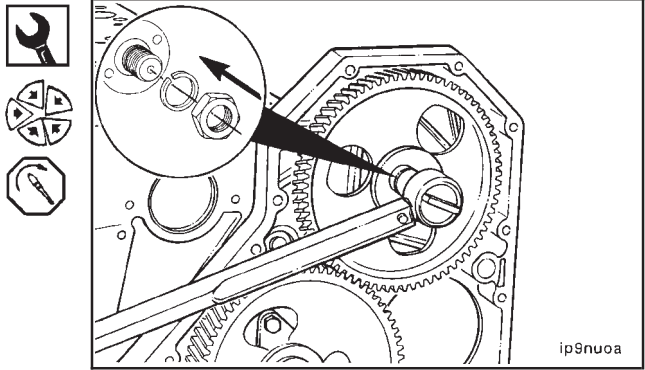

Disengage the engine timing pin.

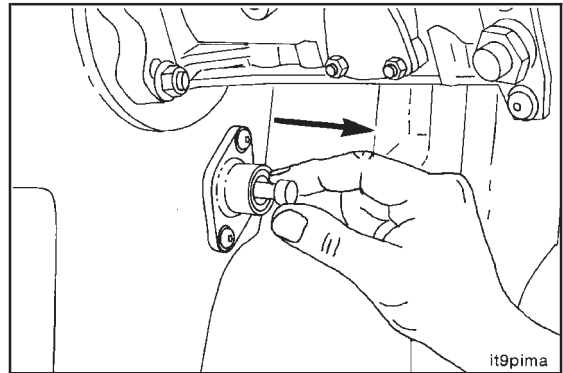

**24 mm**

Remove the fuel pump timing pin plug, Reverse the position of the pin and install the pin, plug, and sealing washer.

**Torque Value:** 15 N•m [11 ft-lb]

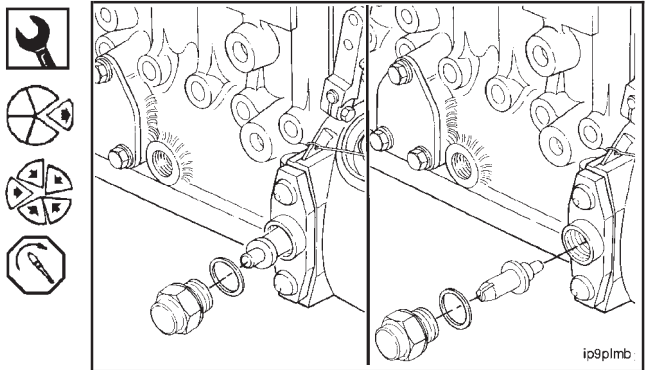

**30 mm**

Tighten the fuel pump drive nut.

**Torque Value:** 165 N•m [122 ft-lb]

Install the gear cover access cap hand tight.

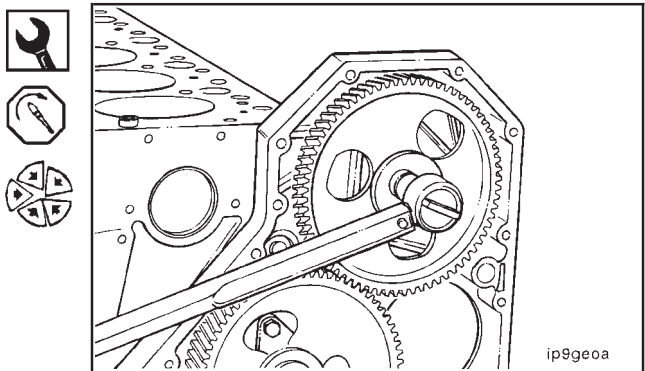

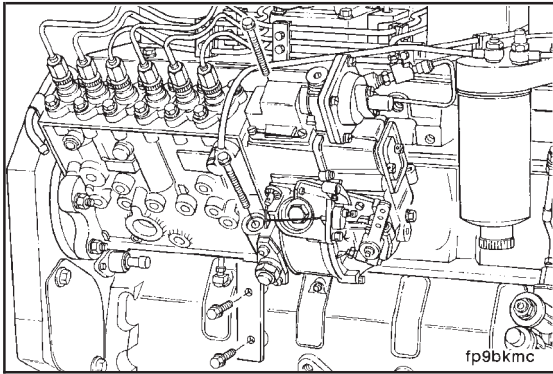

10 mm

Install the fuel pump mounting bracket cap screws.

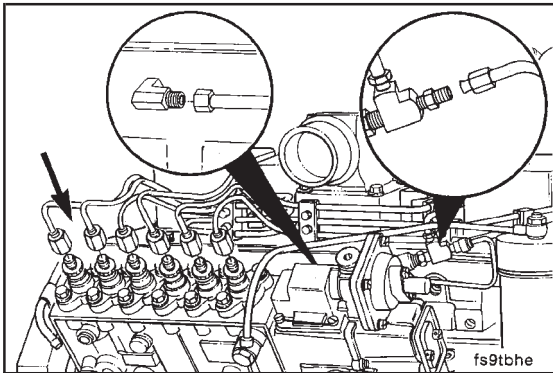

Install the fuel lines, control linkage and turbocharger wastegate line.



**Torque Values:**

High Pressure Fuel Lines	24 N•m [18 ft-lb]
Low Pressure Fuel Supply Fitting	32 N•m [24 ft-lb]
AFC Fittings	9 N•m [80 in-lb]

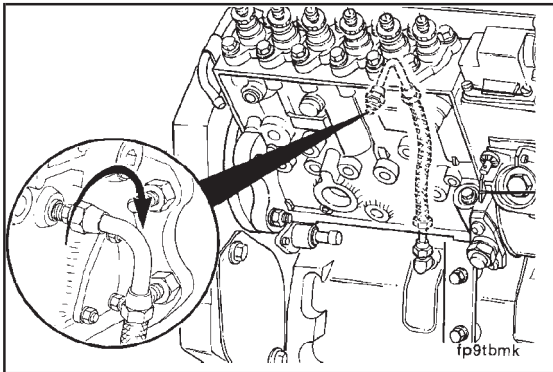

9/16 in

Install the external oil feed line at the inboard side of the fuel pump and the main oil rifle.



**Torque Value:** 10 N•m [7 ft-lb]

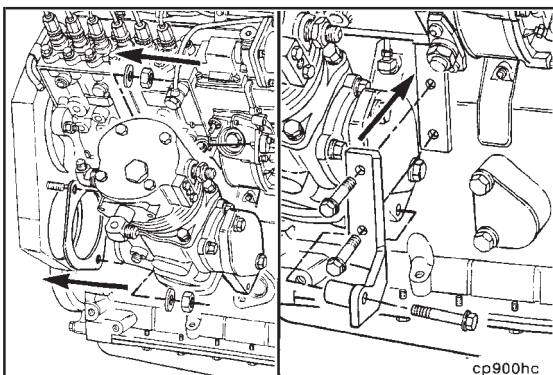

**Accessories - Installation (0-94)**

Install the cover plate or any additional gear driven accessories (hydraulic pump, air compressor, etc.) as needed.

**NOTE:** When gear driven accessories are installed, be sure to install the correct support bracket.

### Flywheel Housing - Installation (0-95)

If removed, install the two ring dowels.

Drive the dowels in until they are against the bottom of the bore.

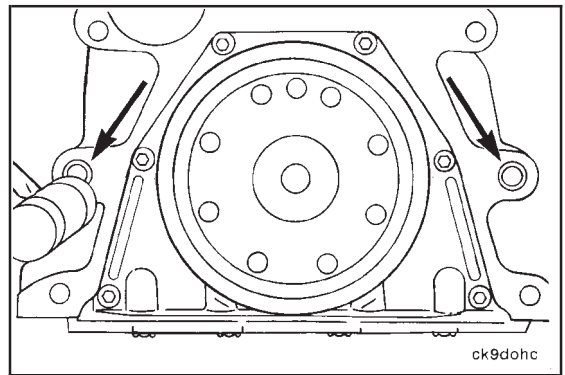

ck9dohc

Install the rectangular seal and lubricate with Lubriplate® 105..

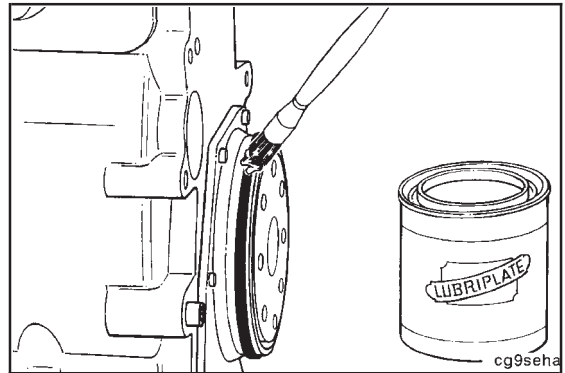

cg9seha

**15 mm**

Install the flywheel housing.

**Torque Value:** 77 N•m [57 ft-lb]

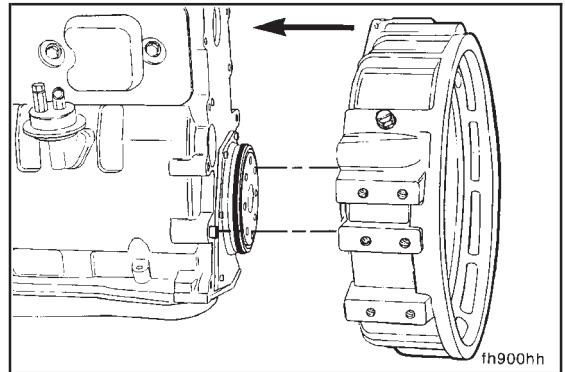

th900hh

### Flywheel - Installation (0-96)

Install the flywheel.

**Caution:** Install two capscrews in the front of the crankshaft or otherwise lock the crankshaft to tighten the flywheel capscrews. Do not use the timing pin to lock the engine.

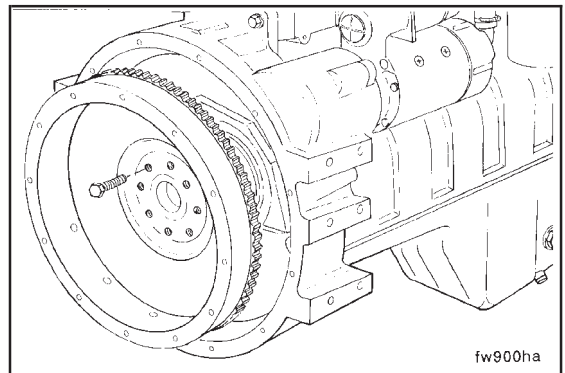

fw900ha

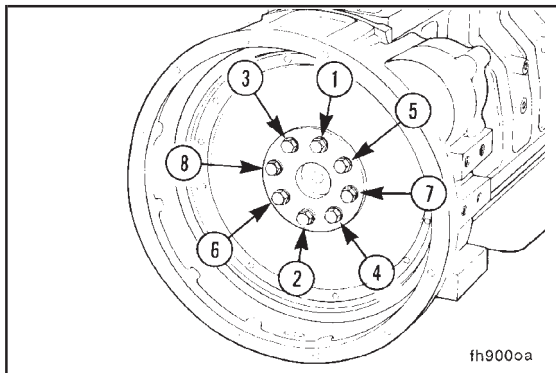

18 mm

Follow the illustrated sequence to tighten the capscrews.



Torque Value: 137 N•m [101 ft-lb] sequence

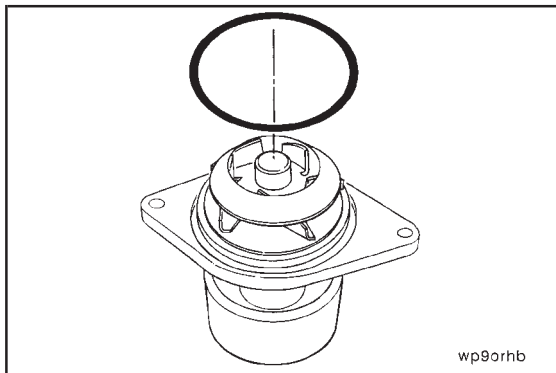

### Water Pump - Installation (0-97)

Install the o-ring in the groove in the water pump housing.

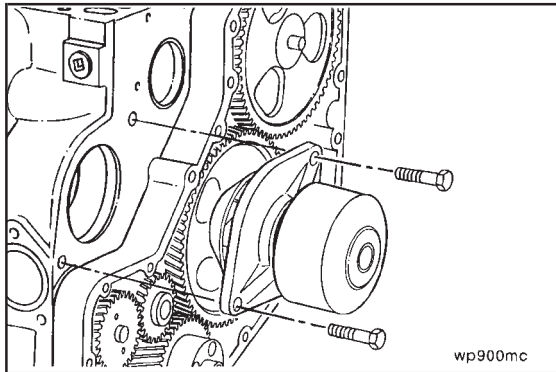

13 mm

Install the water pump.



Torque Value: 24 N•m [18 ft-lb]

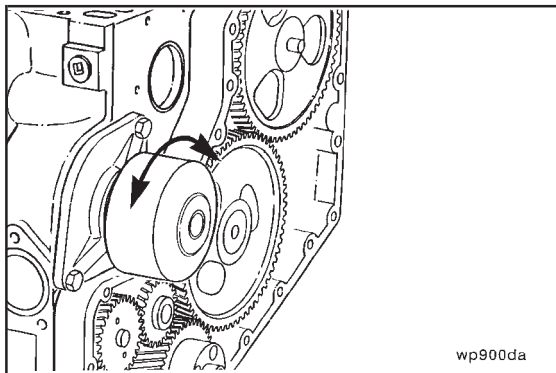

Rotate the water pump to make sure it turns freely.

### Front Cover - Installation (0-98)

Lubricate the front gear train with clean engine oil.

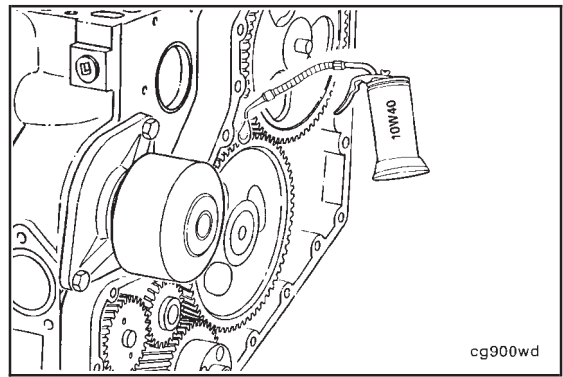

**Caution:** The seal lip and the sealing surface on the crankshaft must be free from all oil residue to prevent seal leaks.

Thoroughly clean and dry the front seal area of the crankshaft.

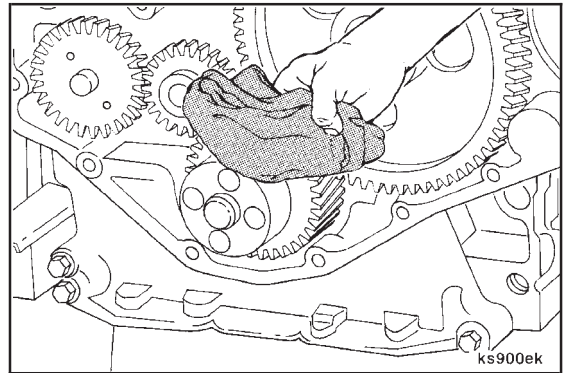

### 3824498 Installation Tool

Leave the plastic pilot installation tool in the lubricating oil seal.

Position the seal on the service tool, Part No. 3824499, with the lubricating oil seal dust lip facing outward.

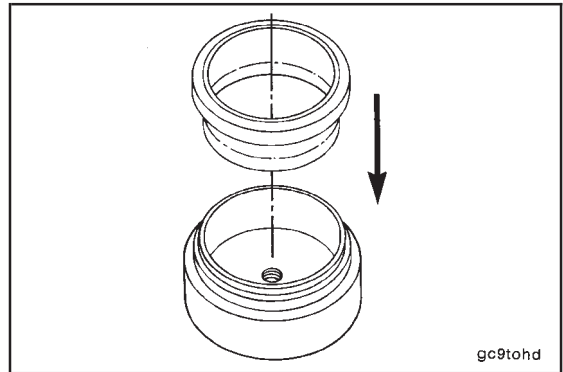

**NOTE:** Properly support the front cover lubricating oil seal flange to prevent damage to the lubricating oil seal and front cover.

Press the lubricating oil seal into the front cover from the back side of the cover toward the front side of the cover.

Press the lubricating oil seal until the service tool bottoms against the front cover.

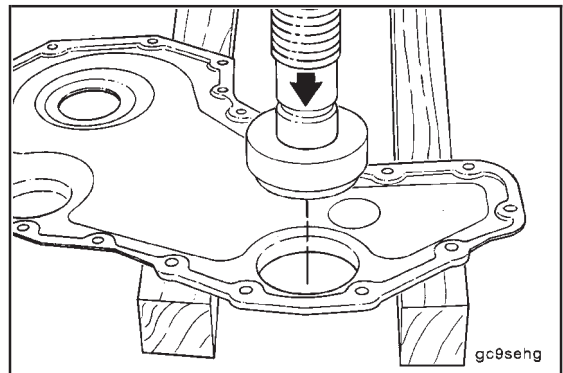

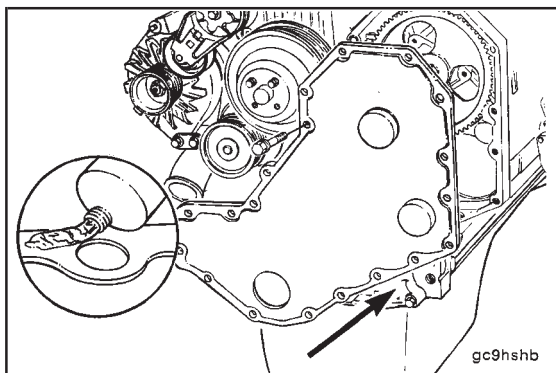

Apply a thin bead of Three Bond™ to the cover side of the front cover gasket only.

**NOTE:** Do not remove the plastic seal pilot tool from the lubricating oil seal at this time. Use the plastic seal pilot tool to guide the seal on the crankshaft.

Install the gasket and front cover on the engine.

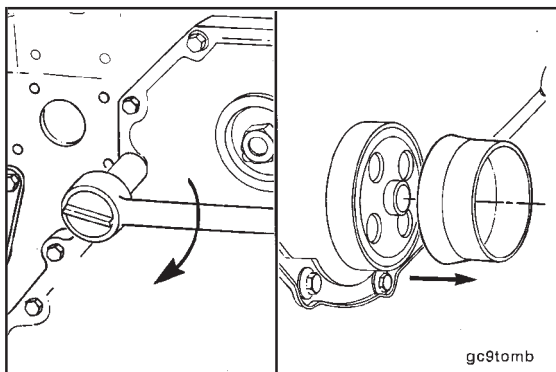

10 mm

Remove the alignment/installation tool after tightening the capscrews.



**Torque Value:** 24 N•m [18 ft-lb]

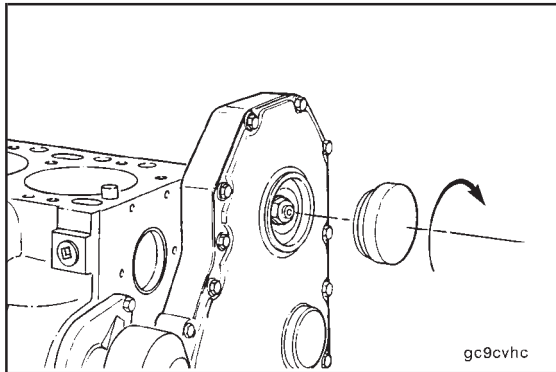

Install the front cover access cap and seal.

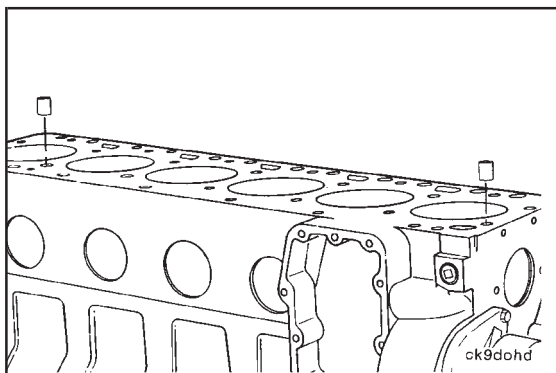

### Cylinder Head - Installation (0-99)

**Caution:** Make sure the cylinder head and block surface are clean and not nicked or gouged.



**Mallet**

If removed, install the two cylinder head dowels. Drive the dowels to the bottom of the dowel bore.



**Caution:** Be sure the gasket is correctly aligned with holes in the block.

Position the head gasket over the dowels.

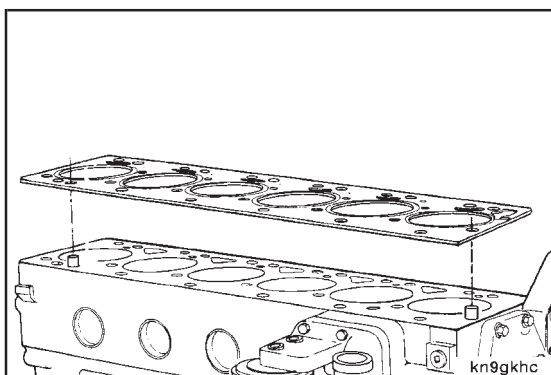

Carefully put the cylinder head on the block and seat it onto the dowels.

**Cylinder Head Weight:**

4 Cylinder - 36 Kg [80 lb]

6 Cylinder - 51.3 Kg [114 lb]

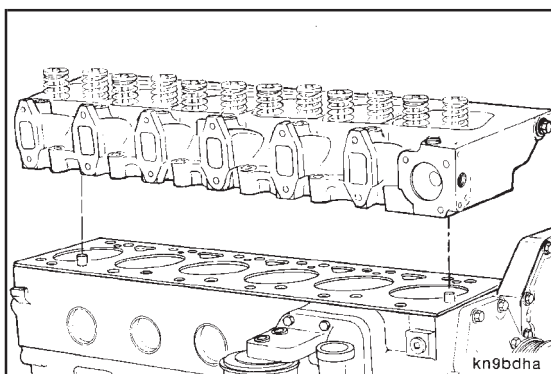

**Push Rods - Installation (0-100)**

Position the push rods into the valve tappets.

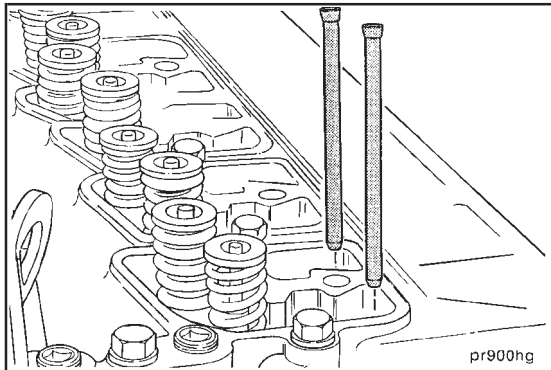

Lubricate the push rod sockets with engine oil.

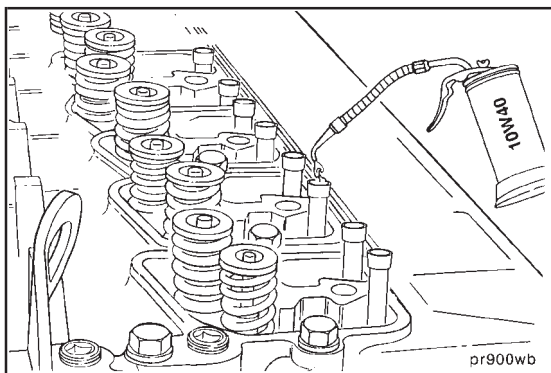



### Rocker Levers - Installation (0-101)

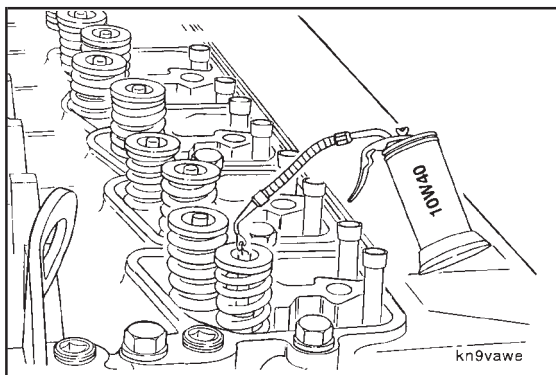

Lubricate the valve stems with engine oil.

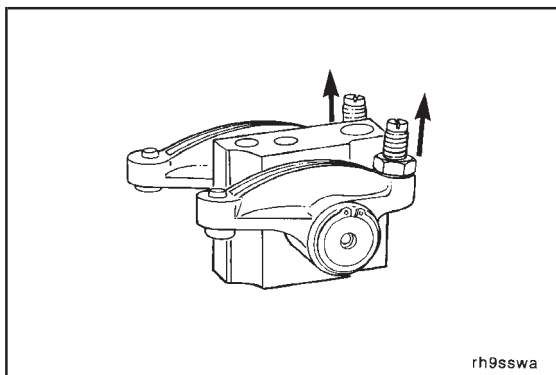

**14 mm, Flat Blade Screwdriver**

Completely loosen the rocker lever adjusting screws.

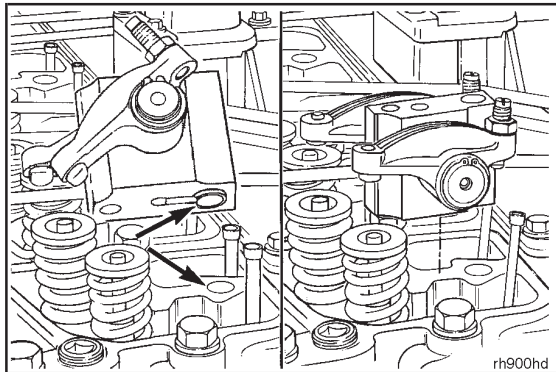

**NOTE:** The rocker lever pedestals are aligned with dowels.  
Install the pedestals.

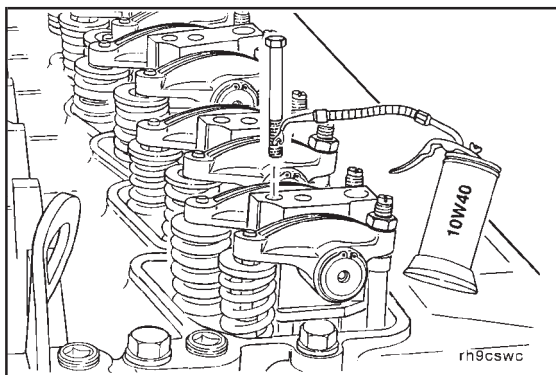

Lubricate the 8mm pedestal cap screw threads and under the cap screw heads with engine oil.



Install the cap screws finger tight.

Lubricate the 12mm pedestal/head capscrew bolt threads and under the capscrew heads with engine oil.

Install the capscrews finger tight.

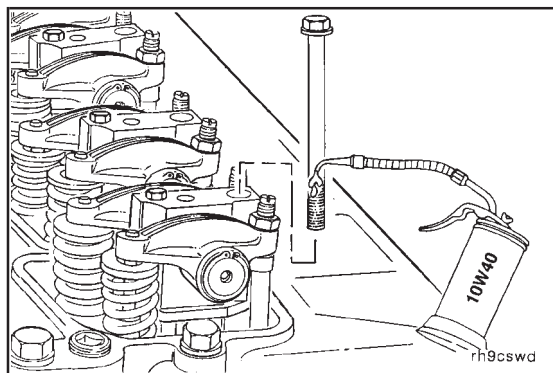

Lubricate the threads and under the heads on the remaining head capscrews with engine oil.

Install the capscrews finger tight.

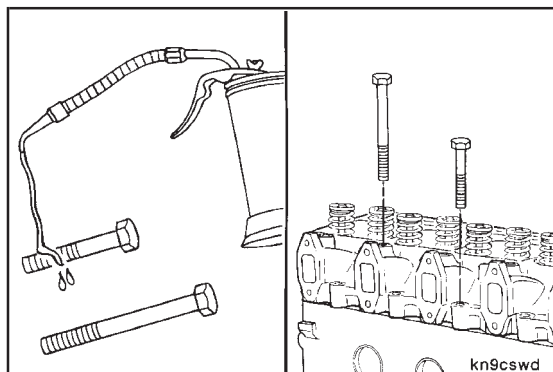

### Cylinder Head - Tightening (0-102)

Use the illustrated sequence to tighten the cylinder head capscrews.

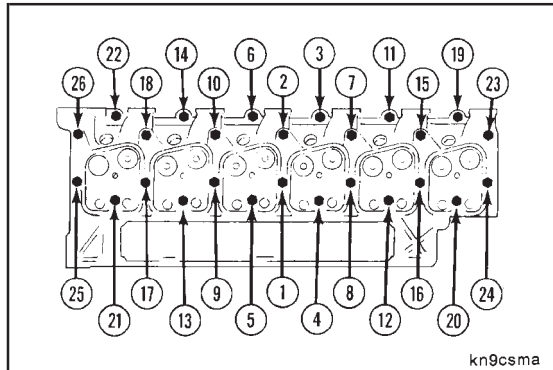

Follow the numbered sequence as shown above and tighten all capscrews to 90 Nm [66 ft-lb].

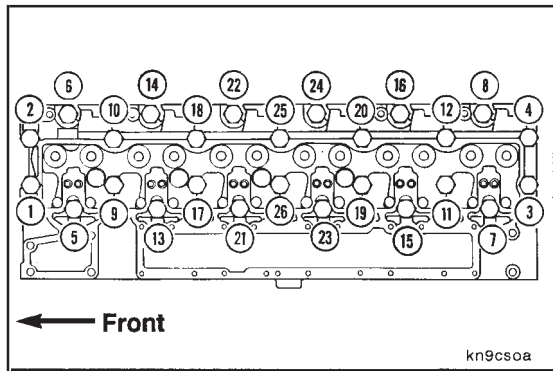

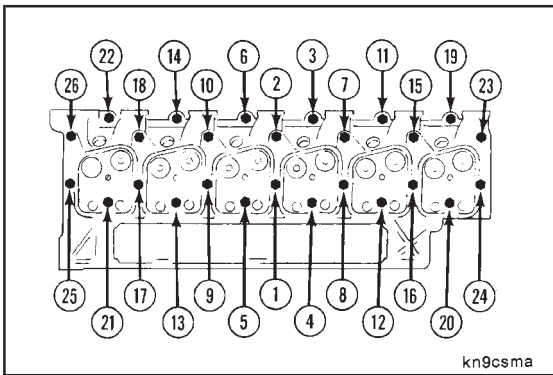

Follow the numbered sequence and recheck the torque on all cap screws to 90 Nm [66 ft-lb].

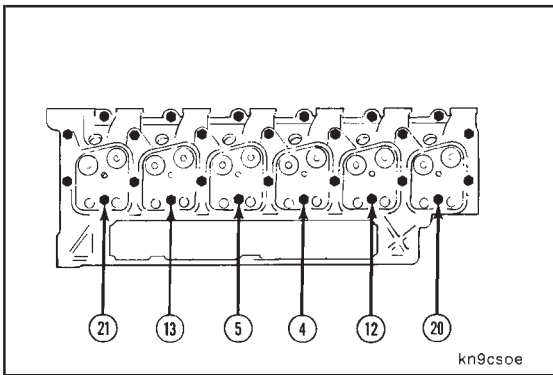

Follow the numbered sequence and tighten ONLY THE SIX LONG CAPSCREWS (No. 4, 5, 12, 13, 20, 21) to 120 Nm [89 ft-lb].

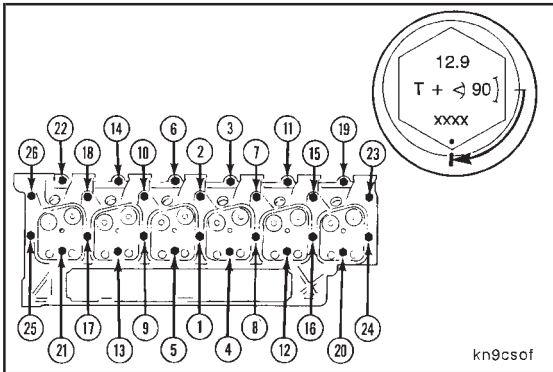

Follow the numbered sequence and turn all cap screws an additional 90° of rotation.

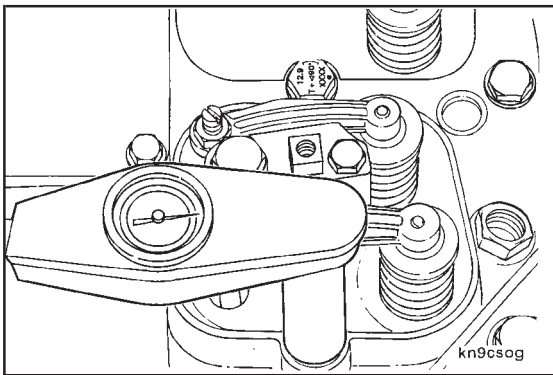

As an overcheck to make sure all cap screws have been rotated 90°, check the torque on all cap screws to 136 Nm [102 ft-lb]. If any cap screws turn at 136 Nm [102 ft-lb] loosen only that cap screw and retighten using the above mentioned sequence.

**13 mm**

Tighten the 8mm pedestal capscrews.

**Torque Value:** 24 N•m [18 ft-lb]

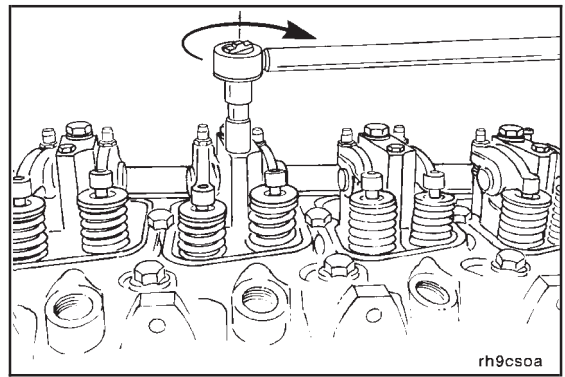

**Valve Clearance - Adjustment (0-103)**

Turn the valve adjustment screws in until they touch the push rod sockets. Loosen them one full turn.

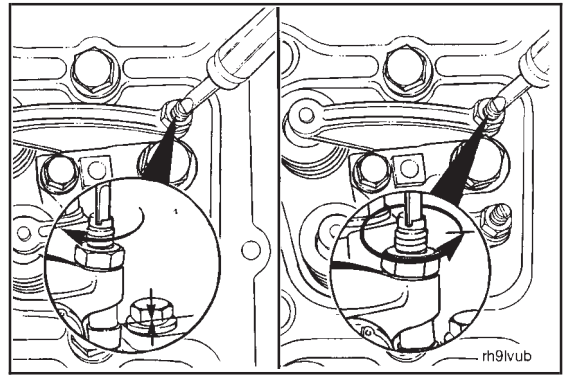

Locate TDC for Cylinder Number 1.

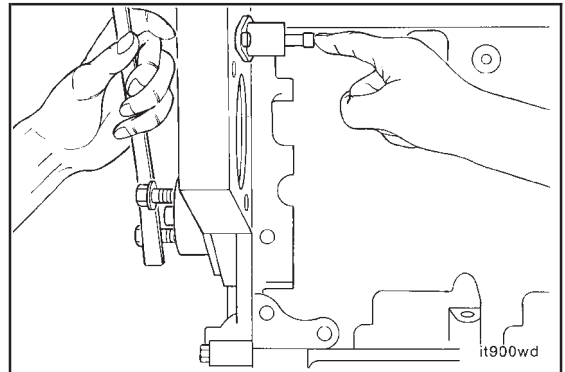

Disengage the timing pin.

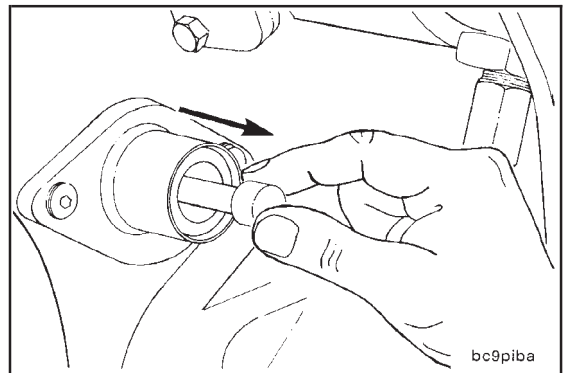

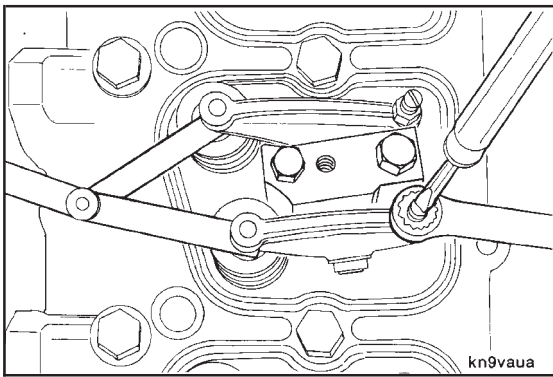

**Feeler Gauge**

**Valve Stem to Rocker Lever Clearance**

**Intake Valve**  
0.254 mm  
[0.010 in]

**Exhaust Valve**  
0.508  
[0.020 in]

The clearance is correct when some resistance can be "felt" when the feeler gauge is pulled through the space between the valve stem and rocker lever.

Adjust the valves as indicated in the following illustrations. Tighten the locknuts and check the clearance again.

**Torque Value:** 24 N•m [18 ft-lb]

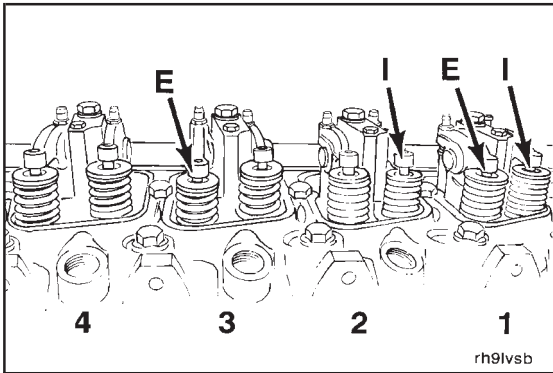

**Caution:** Perform step A of the valve set procedure with Cylinder Number 1 at TDC compression stroke (timing pin will engage).



**Step A - Four Cylinder**

Cylinder	Valve	
	I = Intake	E = Exhaust
1	*	*
2	*	-
3	-	*
4	-	-

(\* = Set)

(- = Do not Set)

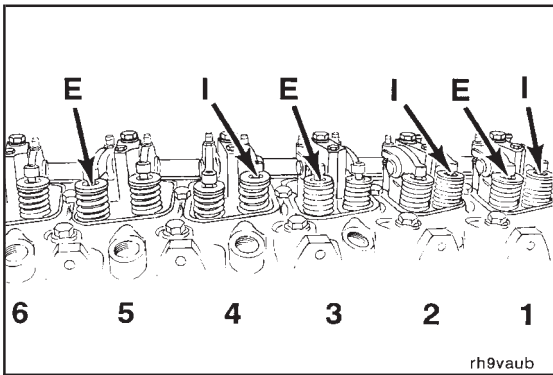

**Step A - Six Cylinder**

Cylinder	Valve	
	I = Intake	E = Exhaust
1	*	*
2	*	-
3	-	*
4	*	-
5	-	*
6	-	-

(\* = Set)

(- = Do not Set)

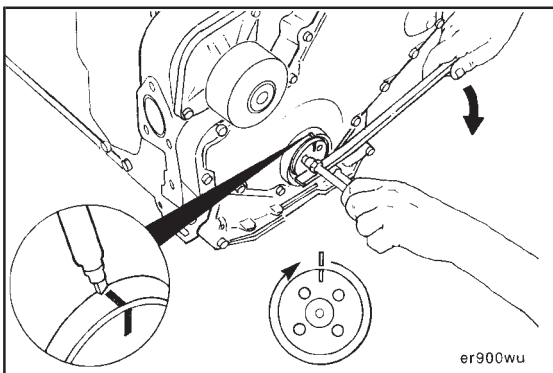

**Perform Step B of the valve set procedure with Cylinder Number 1 at TDC plus 360 degrees (timing pin will not engage).**

Mark the crankshaft and front cover. Rotate the crankshaft one full turn.

**Step B - Four Cylinder**

Cylinder	Valve	
	I = Intake	E = Exhaust
1	-	-
2	-	*
3	*	-
4	*	*

(\* = Set)  
(- = Do not Set)

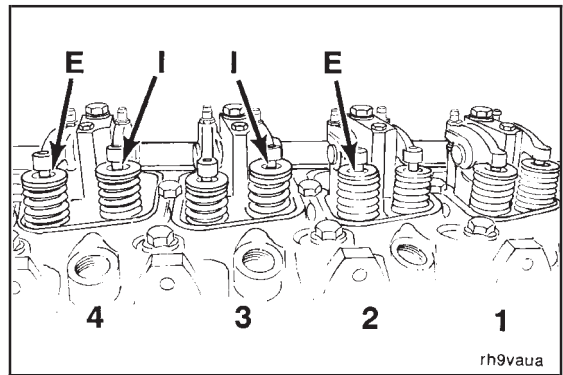

**Step B - Six Cylinder**

Cylinder	Valve	
	I = Intake	E = Exhaust
1	-	-
2	-	*
3	*	-
4	-	*
5	*	-
6	*	*

(\* = Set)  
(- = Do not Set)

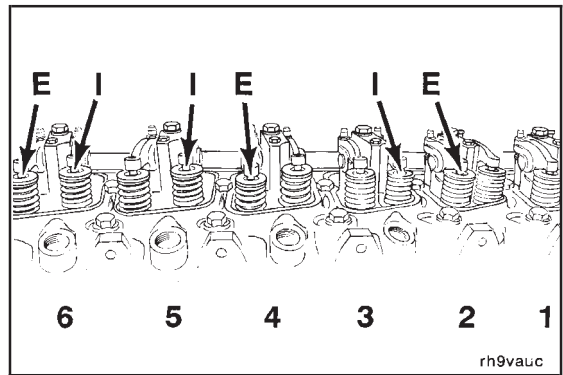

**Injector Nozzles - Installation (0-104)**

Apply a coat of anti-seize compound to the threads of the injector hold-down nut and between the top of the nut and injector body (A). Avoid getting anti-seize compound in the fuel drain hole (B).

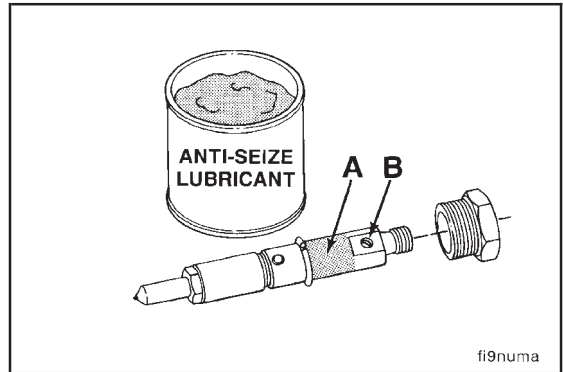

Assemble a sealing washer on each injector.

**Use only one sealing washer.**

**NOTE:** A light coat of clean 15W-40 engine oil between the washer and injector can help to keep the washer from falling during installation.

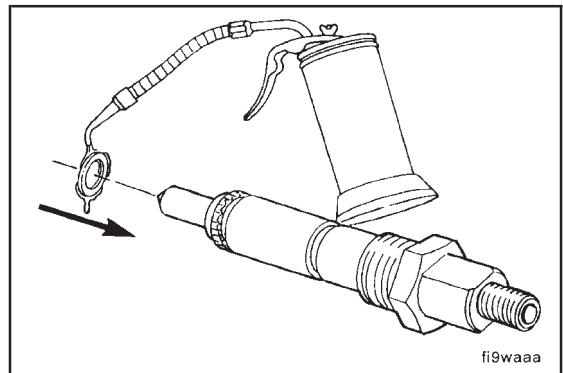

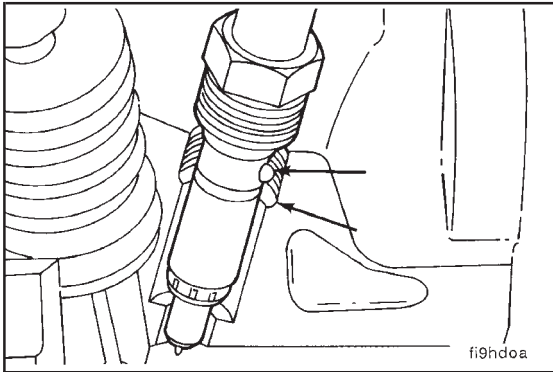

**24 mm Deep Well Socket**

Install the injectors.



Tighten the injector nozzle nuts.

**Torque Value:** 60 N•m [44 ft-lb]



**NOTE:** The protrusion on the side of the nozzle fits into a notch in the cylinder head to orient the injector.

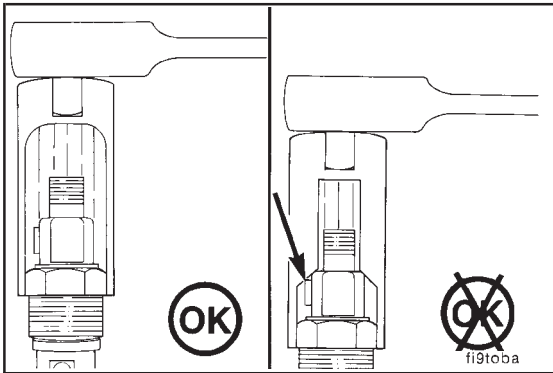

**Caution:** Some sockets can damage the sealing surface of the fuel drain outlet.

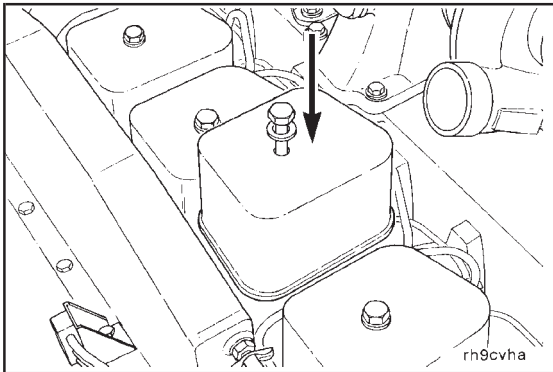

**Valve Covers - Installation (0-105)**

**16 mm**

Assemble the gaskets, valve covers, o-rings and special cap screws.



**Torque Value:** 24 N•m [18 ft-lb]

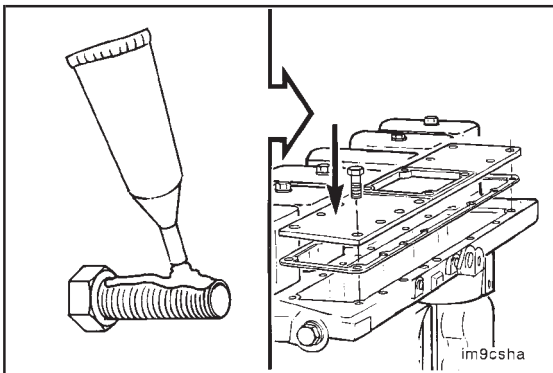

**Manifold Cover - Installation (0-106)**

**3375066 Sealant**

Apply sealant to the cap screws as shown in the illustration.



Install the manifold cover, gasket and cap screws.

Do not tighten the cap screws until the high pressure line brackets are assembled.

**Aftercooler - Installation (0-107)**

**3375066, 3823494 Sealant**

Apply sealant, Part No. 3375066, to the capscrews as shown in the illustration.

Apply a 4 mm bead of sealant, Part No. 3823494, around the sealing surface of the aftercooler as shown in the illustration.

Install the aftercooler. Do **not** tighten the capscrews until the high pressure fuel line brackets are installed.

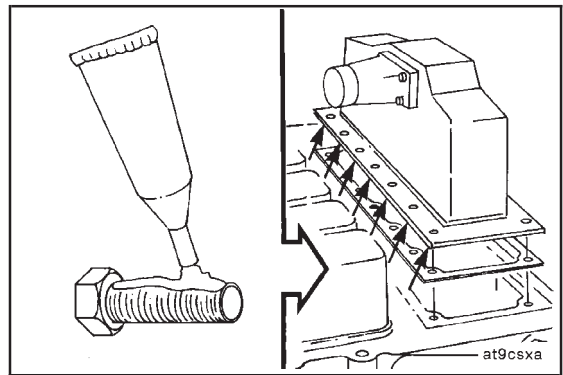

**Fuel Lines - Installation (0-108)**

**17 mm**

Install the fuel filter supply line.

The banjo fittings at the filter head require sealing washers on each side of the line. The banjo fitting with the vent screw is used to install the pump supply line.

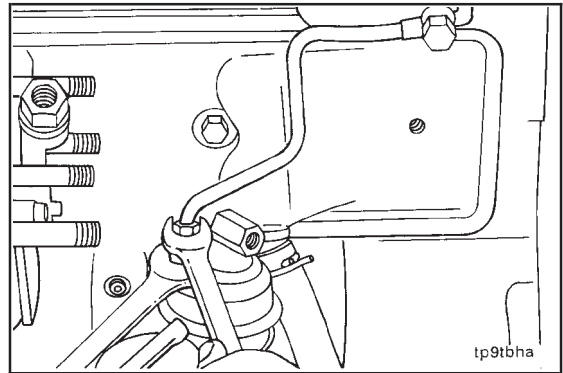

**Injection Pump Supply Line - Installation (0-109)**

**17 and 14 mm**

Install the Bosch injection pump supply line.

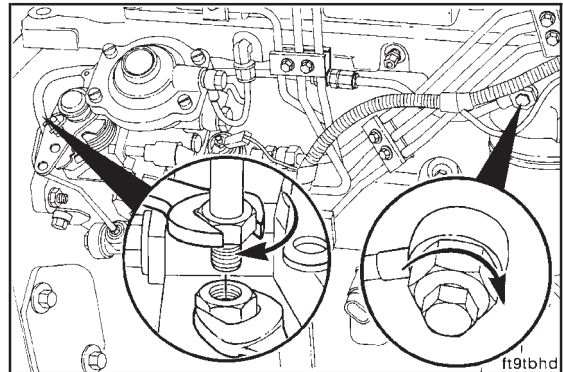

**17 and 14 mm**

Install the injection pump fuel supply line for the CAV or Stanadyne injection pump.

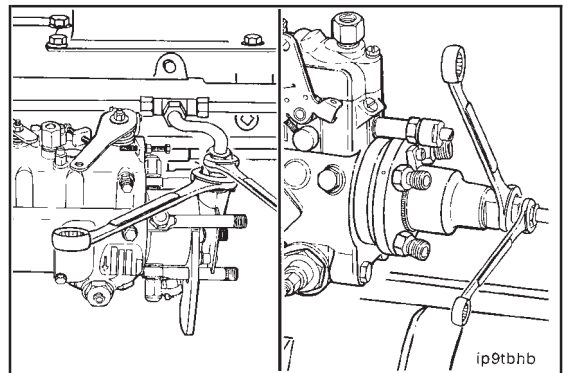



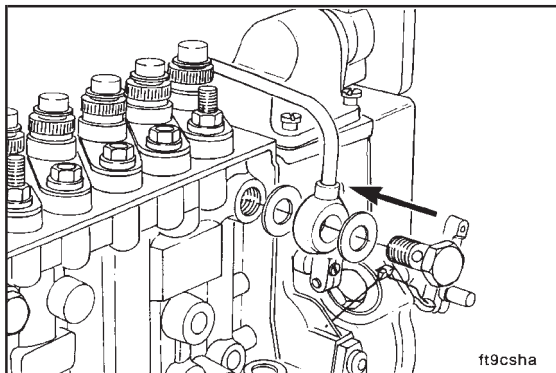

19 mm and 17 mm

Install the Bosch P7100 injection pump fuel supply line.

Torque Value: 32 N•m [24 ft-lb]

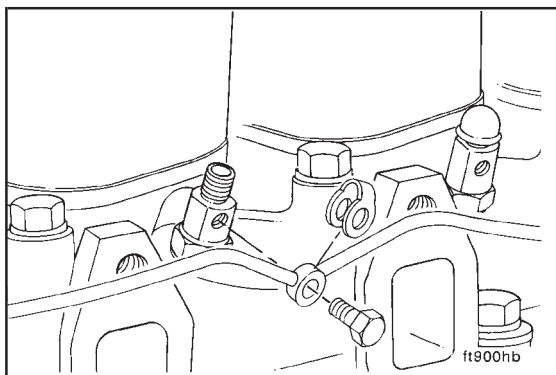

**Fuel Drain Manifold - Installation (0-110)**

10 mm

Use new sealing washers for the fuel drain manifold.

Install the fuel drain manifold.

Torque Value: 9 N•m [80 in-lb]

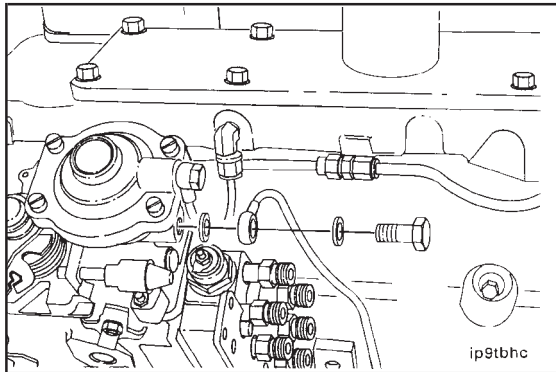

**Injection Pump Vent Line - Installation (0-111)**

10 and 19 mm

Connect the Bosch injection pump vent.

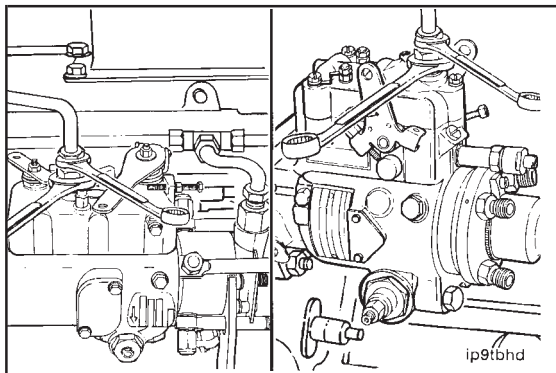

10 and 16 mm

Connect the injection pump vent for the CAV or Stanadyne injection pump.



**19 mm**

Connect the Bosch P7100 injection pump vent.

**Torque Value:** 32 N•m [24 ft-lb]

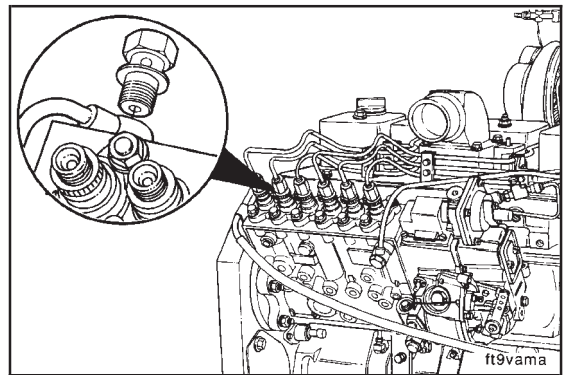

**High Pressure Fuel Lines - Installation (0-110)**

Assemble the high pressure fuel lines.

The number one cylinder delivery valve is marked on the pump as illustrated.

4 cylinder = A  
6 cylinder = D

Firing Order

4 Cylinder            6 Cylinder

A = 1                    D = 1

B = 3                    E = 5

C = 4                    F = 3

D = 2                    A = 6

B = 2

C = 4

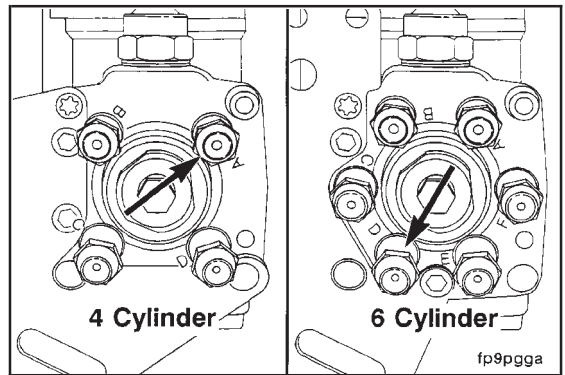

**13 mm**

Tighten all of the manifold cover capscrews.

**Torque Value:** 24 N•m [18 ft-lb]

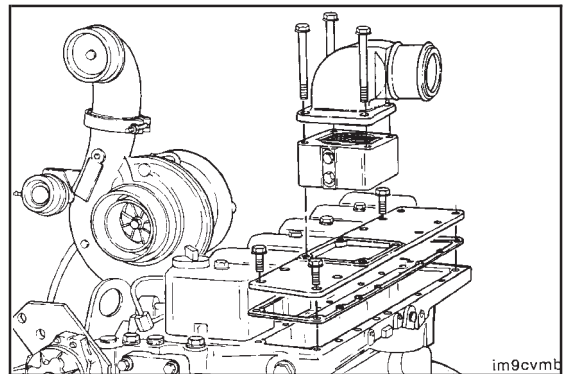

**14 mm, 17 mm**

Make sure that the high pressure lines will not rub against other engine components.

Tighten the high pressure lines at the injection pump and injectors securely.

**Torque Value:** 24 N•m [18 ft-lb]

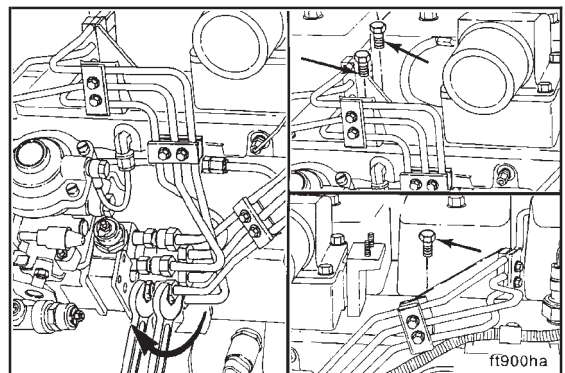

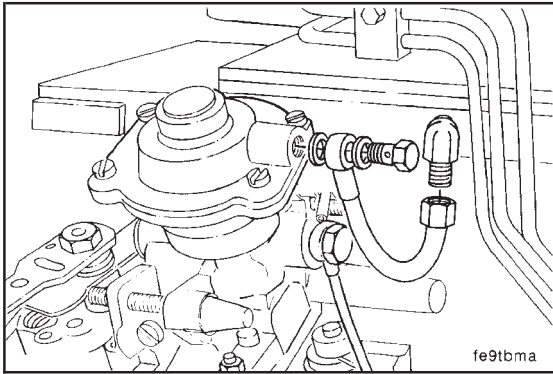

12 mm and 13 mm

Install the air fuel control tube.



Use new sealing washers when installing the tube.

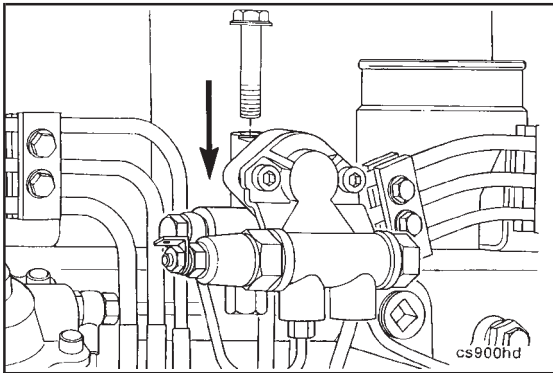

### KSB (Remote Mounted) - Installation (0-113)

13 mm and 10 mm

Install the remote mounted KSB valve (if equipped) as illustrated.



#### Torque Values

Mounting Capscrew - 24 N•m [18 ft-lb]

Banjo Screw - 8 N•m [6 ft-lb]

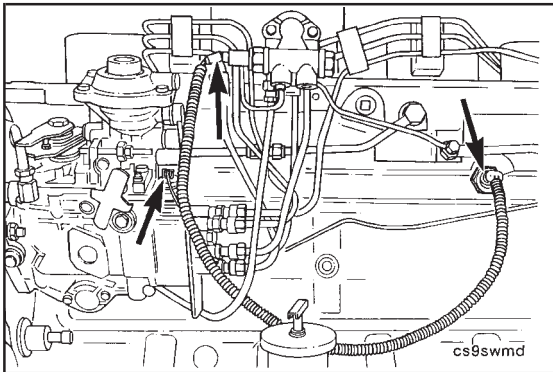

Connect the KSB wiring.

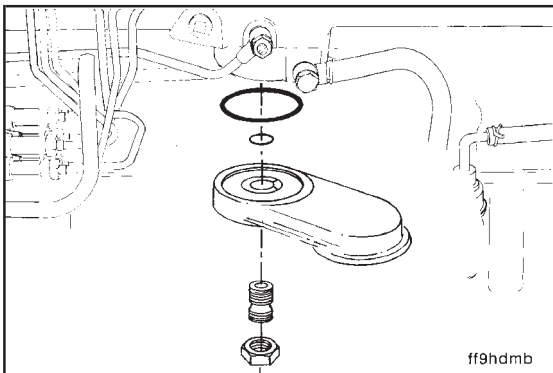

### Fuel Filter Head - Installation (0-114)

If the optional dual filter is to be used, install the adapter and square cut sealing ring.

Lubricate the sealing ring and the center hole with engine oil.

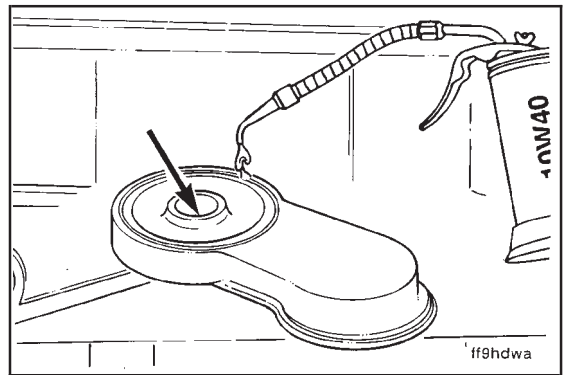

**24 mm**

Install the dual filter head.

Tighten the nut.

**Torque Value:** 32 N•m [24 ft-lb]

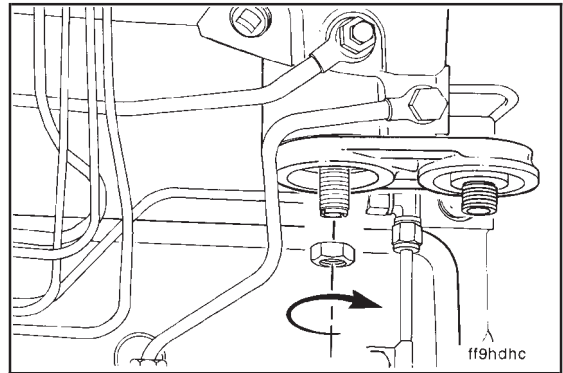

Temporarily install fuel filter(s).

**NOTE:** When the engine is ready to be put into service, fill the filter(s) with clean #2 diesel fuel and tighten 1/2 turn after the lubricated gasket contacts the filter head.

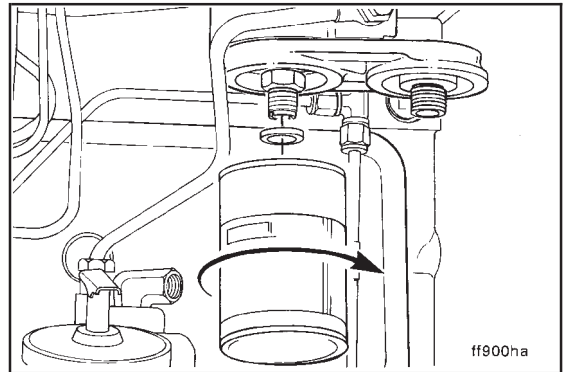

**Exhaust Manifold - Installation (0-113)**

“Package” the exhaust manifold capscrews and gaskets on the manifold. Apply anti-seize compound to the capscrews.

**NOTE:** The bead on the exhaust manifold gasket can be installed in either direction.

**13 mm**

Install the exhaust manifold and gaskets.

**Torque Value:** 43 N•m [32 ft-lb]

Follow the sequence shown.

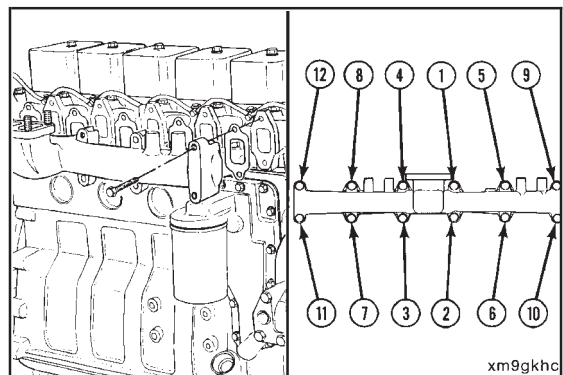

### Turbocharger - Installation (0-116)

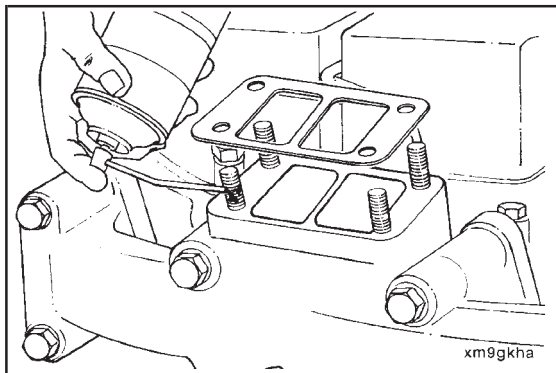

Install the turbocharger gasket and apply anti-seize compound to the mounting studs.

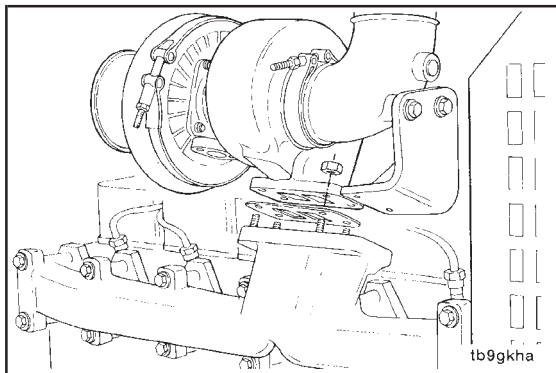

**15 mm**

Install the turbocharger.



**Torque Value: 45 N•m [33 ft-lb]**

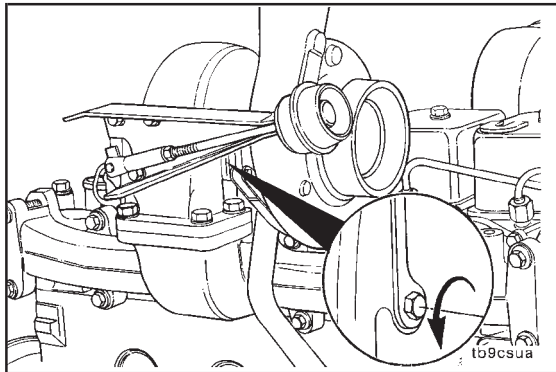

If required, loosen the turbine housing cap screws and position the bearing housing to install the turbocharger drain tube.

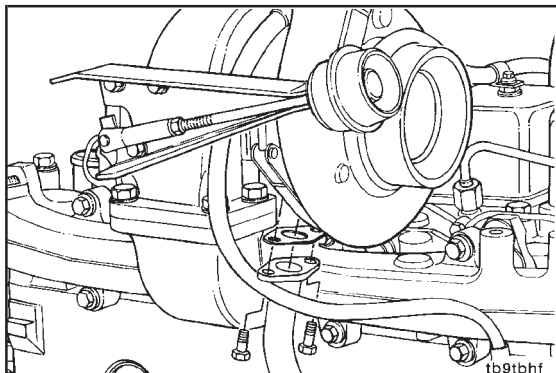

**13 mm**

Install the hose and clamps on the turbocharger drain tube loosely. Install the drain tube and gasket on the turbocharger.



**Torque Value: 24 N•m [18 ft-lb]**



If the drain tube in the block was removed, apply sealant Part Number 3375068 to the sealing surfaces.

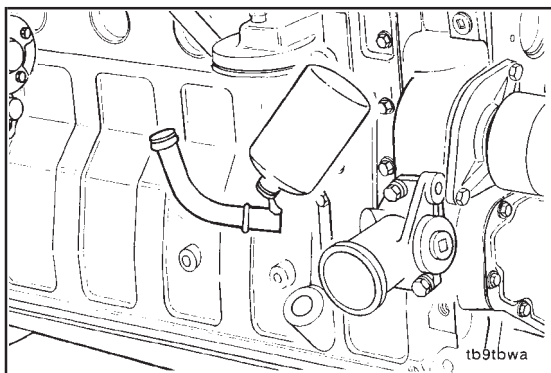

**22 mm Open End Wrench, Hammer**

Install the tube in the block so it is aligned with the turbocharger drain tube.

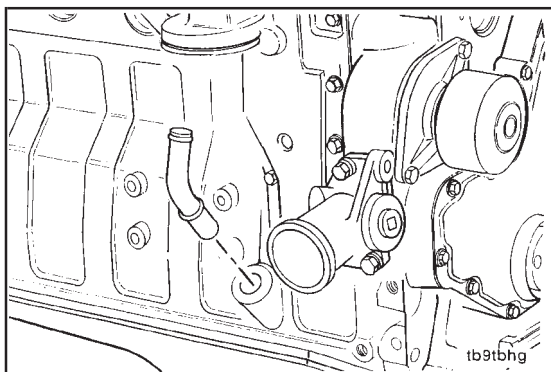

**Screwdriver**

Position the turbocharger drain hose to connect the drain tubes; tighten the clamps.

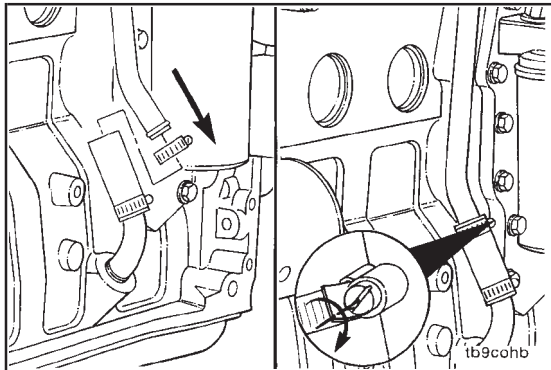

**13 mm**

If loosened, tighten the turbocharger turbine housing capscrews.

**Torque Value:** 20 N•m [15 ft-lb]

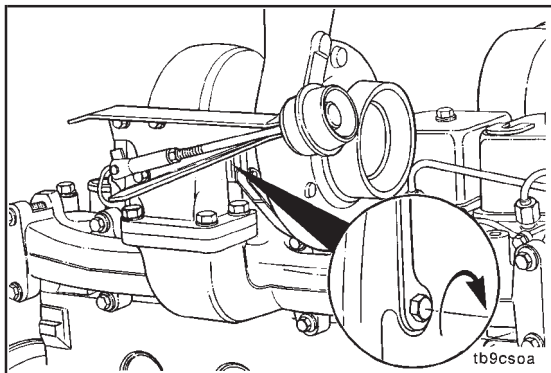

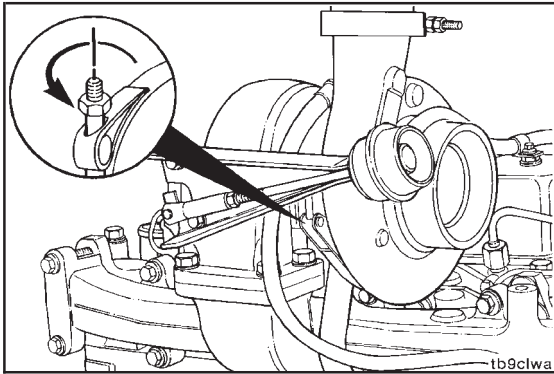

**7/16 Inch**

If required, loosen the compressor housing v-band clamp and position the housing to align with the air crossover tube.

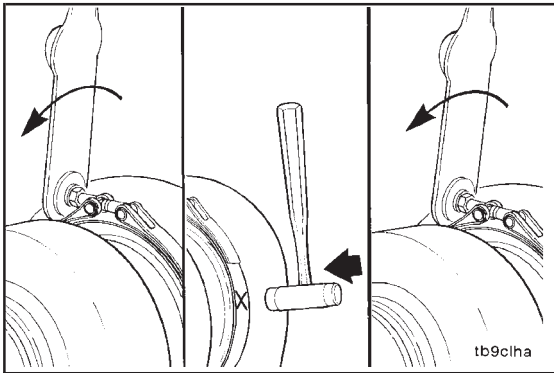

**7/16 Inch Plastic Hammer**

Tighten the band clamp. Tap around the clamp with a plastic hammer and tighten again.



**Torque Value:** 8.5 N•m [75 in-lb]

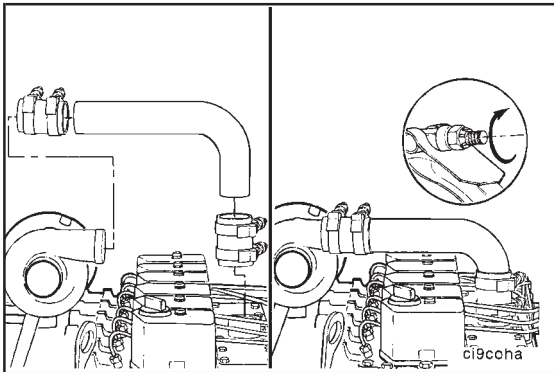

**Screwdriver or 5/16 inch**

Install the air crossover tube and clamps and tighten.



**Torque Value:** 8 N•m [71 in-lb]  
5 N•m [44 in-lb]

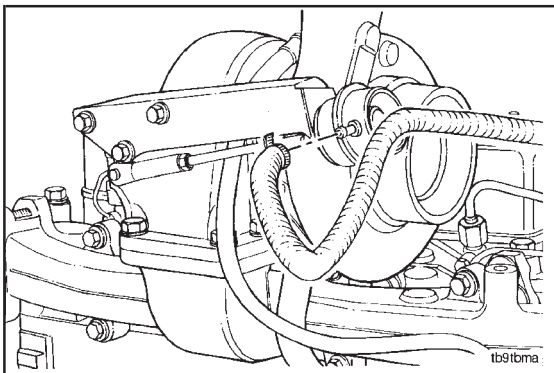

Install the boost control capsule actuator hose.

**Caution:** The Turbocharger must be prelubricated.

Pour 50 to 60cc [2 to 3 oz.] of clean engine oil into the oil inlet fitting on top of the turbocharger while spinning the turbocharger impeller to distribute the oil in the bearing.

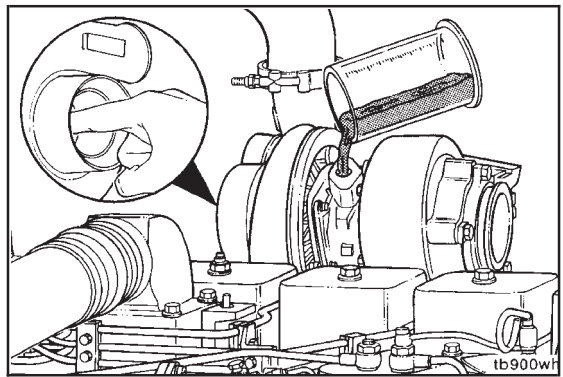

**16 mm and 19 mm**

Install the oil supply line.

Tighten the fittings securely.

**Torque Value:** 15 N•m [11 ft-lb]  
35 N•m [26 ft-lb] (on turbocharger)

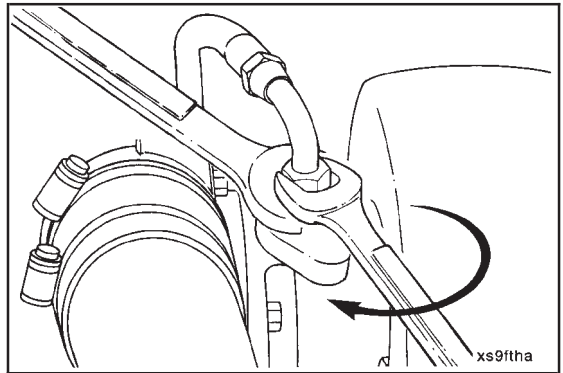

Connect the aftercooler coolant supply tube (1) and the coolant return tube (2).

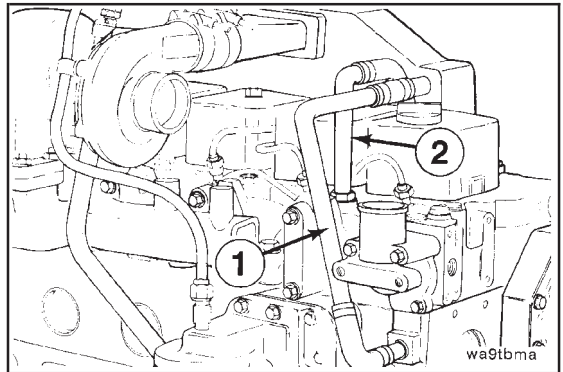

**Thermostat - Installation (0-117)**

“Package” the lifting bracket and thermostat gasket to the thermostat and thermostat housing. Position the rubber seal as shown.

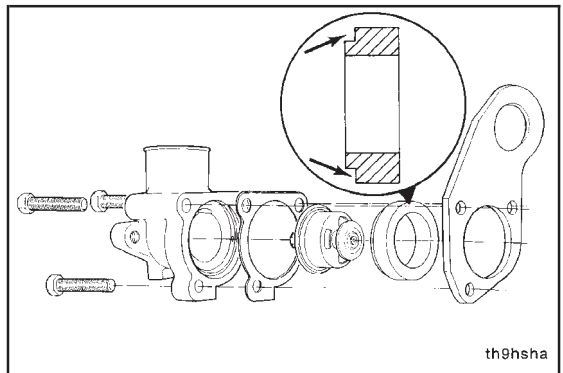



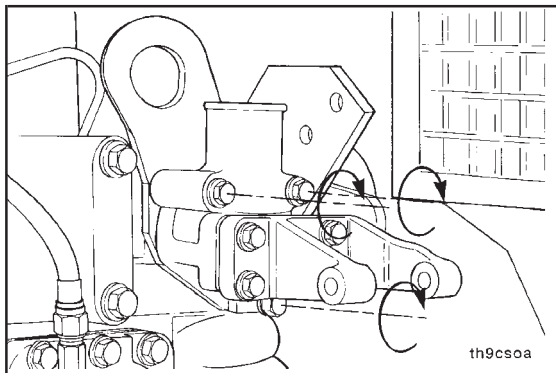

10 mm

Install the "package".



**Torque Value:** 24 N•m [18 ft-lb]

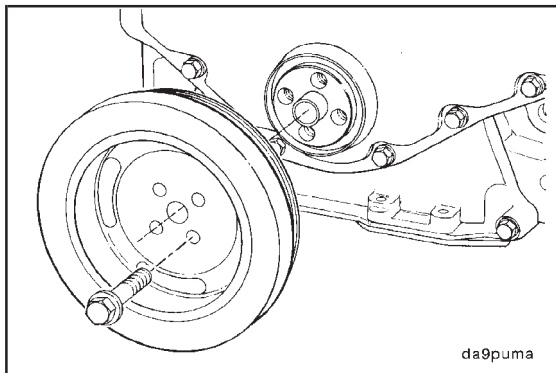

15 mm

Install the crankshaft pulley/vibration damper.



**Torque Value:** 125 N•m [92 ft-lb]



### Vibration Damper - Installation (0-118)

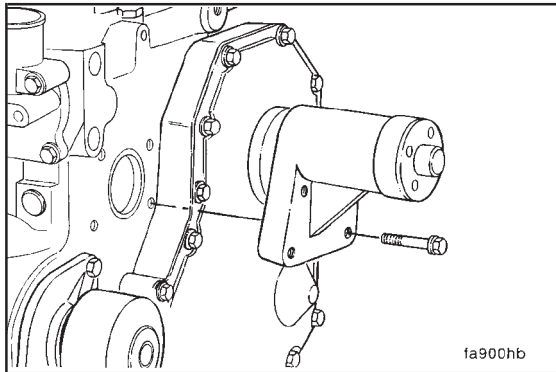

10 mm

Install the fan hub.



**Torque Value:** 24 N•m [18 ft-lb]



### Fan Hub - Installation (0-119)

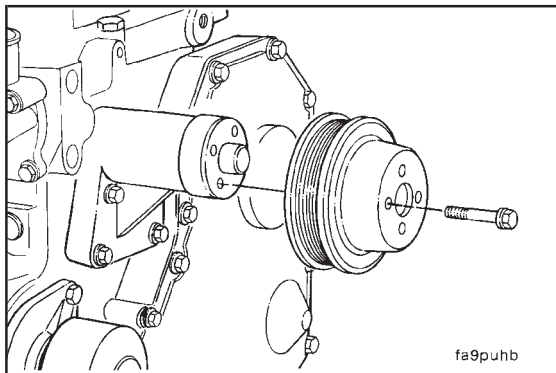

10 mm or 13 mm

Install the fan hub pulley.



**Torque Value**

8 mm Capscrew - 24 N•m [18 ft-lb]

10 mm Capscrew - 43 N•m [32 ft-lb]



### Belt Tensioner - Installation (0-120)

#### 5 mm Allen

Install the tensioner bracket to the cylinder head.

Tighten the socket head screws.

**Torque Value:** 24 N•m [18 ft-lb]

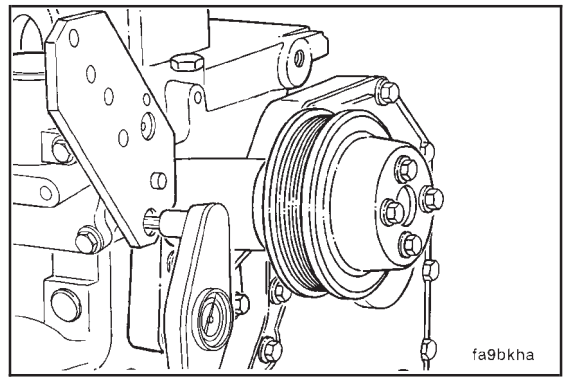

#### 13 mm

Position the belt tensioner on the bracket and secure it with the capscrew.

**Torque Value:** 43 N•m [32 ft-lb]

**NOTE:** Some tensioners can be bolted to two different locations on the bracket. Install into the location dictated by your requirement.

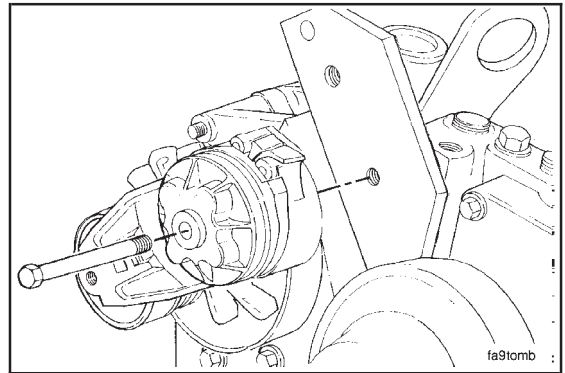

### Water Inlet Connection - Installation (0-121)

**Caution:** Do not tighten at this time. To avoid misalignment and overstressing the lower support mounting ear on the alternator, leave the capscrews loose until all the alternator parts are installed.

Install the water inlet connection and sealing ring.

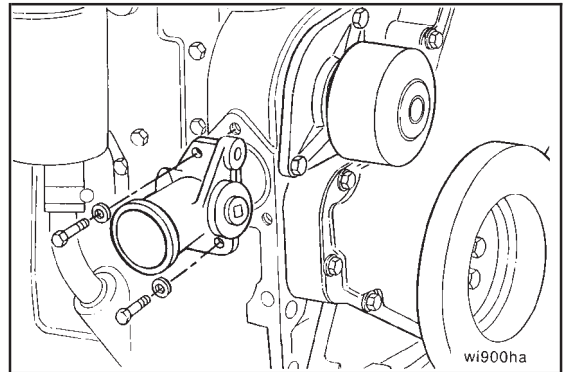

### Alternator - Installation (0-122)

#### 10 mm

Assemble the alternator bracket to the thermostat housing.

**Torque Value:** 24 N•m [18 ft-lb]

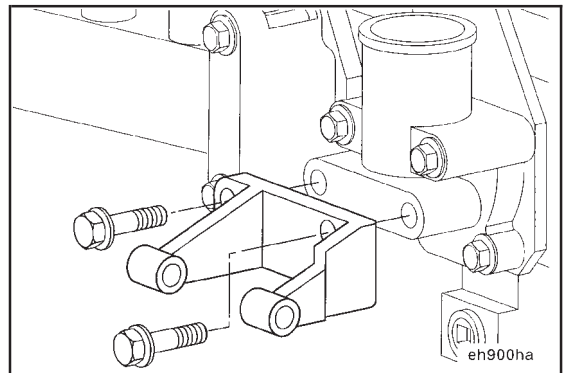

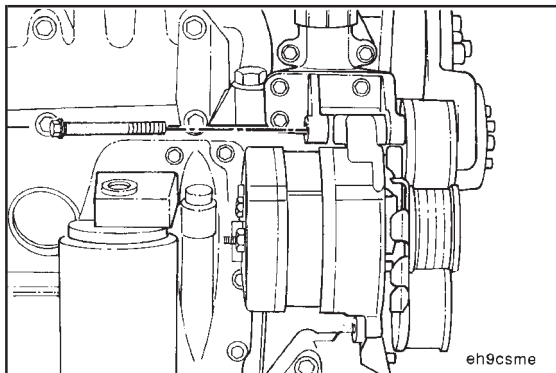

Position the alternator on the bracket and secure it with the mounting cap screw and spacer.

**Do not tighten at this time.**

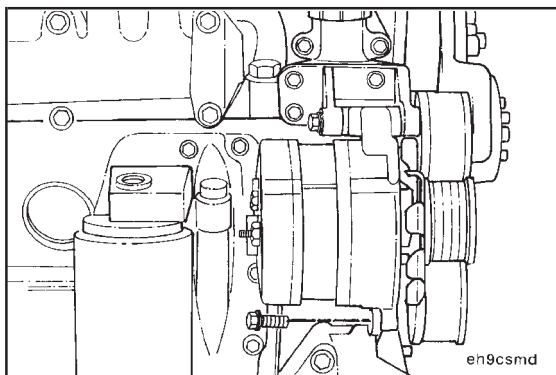

**Caution:** Do not tighten at this time. To avoid misalignment and overstressing the lower support mounting ear on the alternator, leave the cap screws loose until all the alternator parts are installed.



Install the alternator link.

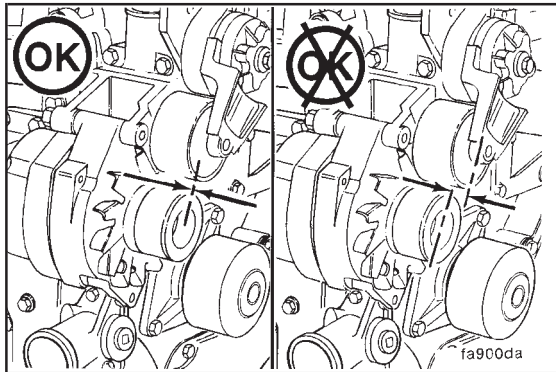

Check the alternator pulley visually or with a straight edge to make sure it is aligned with the other pulleys and is parallel to the front face of the block.

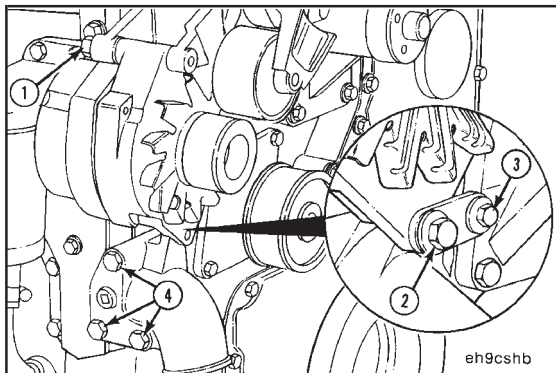

After all parts are assembled, tighten all cap screws in the following sequence:

1. Alternator-to-alternator bracket cap screw.
2. Lower brace-to-alternator cap screw.
3. Alternator-to-water inlet cap screw.
4. Water inlet-to-block cap screws.

**NOTE:** Wrench size and torque value is determined by the make and model of alternator. Refer to the Engine Component Torque Values.

### Drive Belt - Installation (0-123)

#### 3/8 inch Square Drive

Lift the tensioner and install the belt.

**Service Tip:** If difficulty is experienced installing the drive belt (the belt seems too short), position the belt over the grooved pulleys first and then while holding the tensioner up, slide the belt over the water pump pulley.

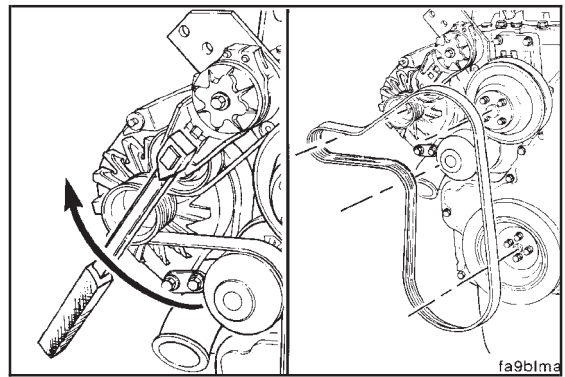

### Oil Filter - Installation (0-124)

Lubricate the filter seal and tighten the filter according to the filter manufacturer's instructions.

Be sure to use the correct filter for your engine. Fleetguard LF3345 is used **only** for the 4B engine. Fleetguard LF3349 can be used for the 4B and 6B engine.

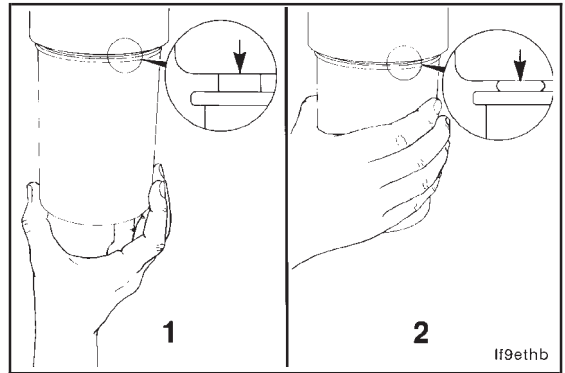

### Rollover Stand - Engine Removal (0-125)

#### 18 mm

Install the rear lifting bracket.

**Torque Value:** 77 N•m [57 ft-lb]

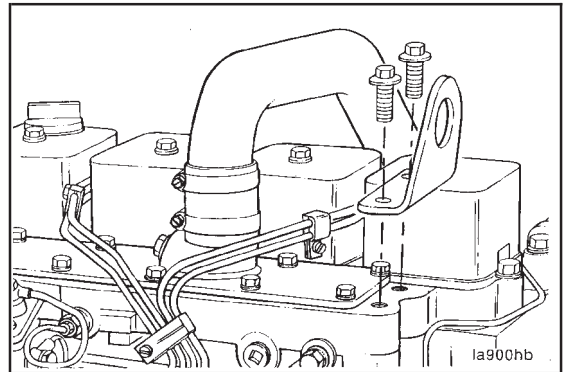

Remove the engine from the rollover stand.

#### Engine Weight

4B engine (wet) weight: 325-350 Kg [715-770 lb]  
6B engine (wet) weight: 410-440 Kg [910-970 lb]

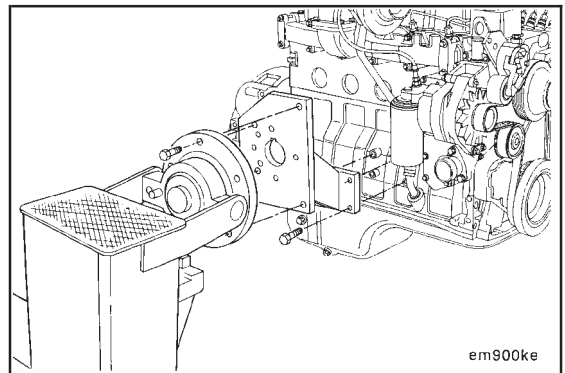

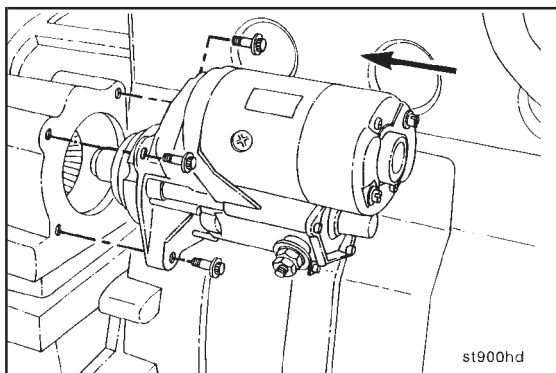

10 mm

Install the starting motor.



Torque Value: 43 N•m [32 ft-lb]



# Section 1 - Cylinder Block - Group 1

## Section Contents

	Page
<b>Balancer - Assembly</b> .....	1-51
<b>Balancer - Disassembly</b> .....	1-48
<b>Camshaft - Cleaning</b> .....	1-29
<b>Camshaft and Gear - Inspection</b> .....	1-29
Camshaft Lobe Edge Deterioration (Breakdown) Criteria.....	1-31
Camshaft Lobe Pitting Reuse Criteria.....	1-30
<b>Camshaft Bushing - Installation</b> .....	1-23
<b>Camshaft Capscrew - Installation</b> .....	1-38
<b>Camshaft Expansion Plug - Installation</b> .....	1-22
<b>Camshaft Gear - Replacement</b> .....	1-34
Camshaft Gear - Installation (Heated Gear Method).....	1-34
Camshaft Gear - Installation (With Special Tool 3823589) .....	1-36
Camshaft Gear - Removal .....	1-34
<b>Connecting Rod - Inspection</b> .....	1-44
<b>Crankshaft - Cleaning</b> .....	1-26
<b>Crankshaft - Inspection</b> .....	1-26
<b>Crankshaft Gear - Replacement</b> .....	1-27
<b>Cylinder Block - Cleaning</b> .....	1-12
<b>Cylinder Block - De-Glazing</b> .....	1-17
<b>Cylinder Block - Disassembly</b> .....	1-10
<b>Cylinder Block - Exploded View</b> .....	1-4
<b>Cylinder Block - General Information</b> .....	1-7
Camshaft: .....	1-7
Crankshaft:.....	1-7
Cylinder Block.....	1-7
Oil Seals .....	1-7
Pistons.....	1-7
Vibration Damper .....	1-7
<b>Cylinder Block - Inspection</b> .....	1-15
<b>Cylinder Block - Precheck Before Disassembly</b> .....	1-10
<b>Cylinder Block - Service Tools</b> .....	1-8
<b>Cylinder Block - Storing</b> .....	1-25
<b>Cylinder Block Group Inspection Checklist</b> .....	1-9
<b>Data Plate - Replacement</b> .....	1-59
<b>Dipstick Tube - Replacement</b> .....	1-25
<b>Expansion and Pipe Plug - Installation</b> .....	1-20
<b>Fuel Pump Stud - Replacement</b> .....	1-58
<b>Gear Housing - Disassembly</b> .....	1-58
<b>Gear Housing and Timing Pin Assembly - Inspection</b> .....	1-57
<b>Piston and Connecting Rod - Assembly</b> .....	1-45
<b>Piston and Connecting Rod - Disassembly</b> .....	1-41
<b>Piston Inspection</b> .....	1-42
<b>Piston Pin - Inspection</b> .....	1-43
<b>Piston, Pin and Connecting Rod - Cleaning</b> .....	1-41

	<b>Page</b>
<b>Piston Ring Gap - Checking .....</b>	<b>1-46</b>
<b>Piston Rings - Installation .....</b>	<b>1-47</b>
<b>Rod Bearing Clearance - Checking .....</b>	<b>1-44</b>
<b>Rubber Element Vibration Damper - Cleaning and Inspection.....</b>	<b>1-39</b>





### Cylinder Block - Exploded View

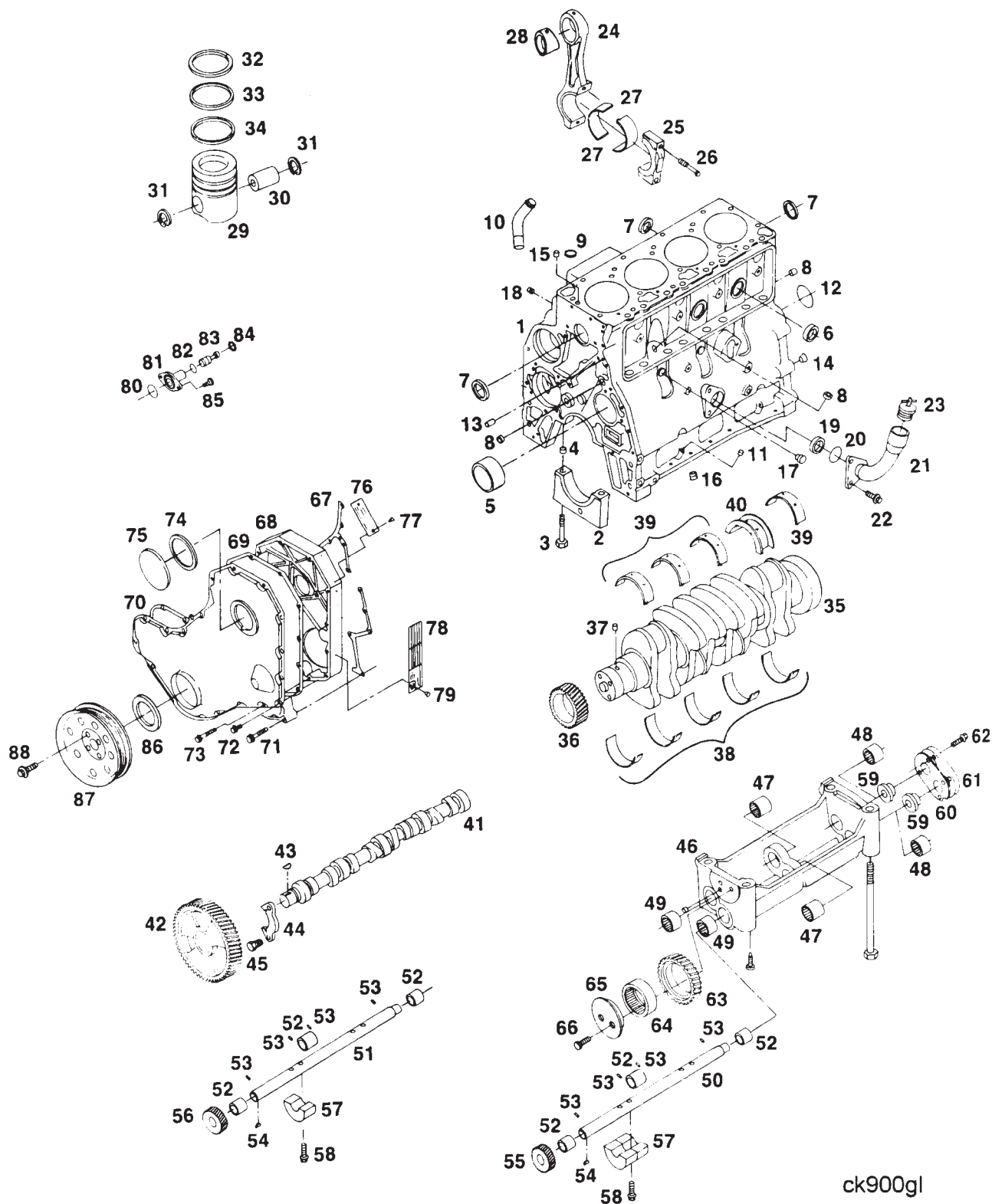

ck900gl

Item	Part Name	Qty.	Remarks
1	Block, Cylinder	1	
2	Cap, Main Bearing	5	7 for 6B
3	Screw, Hex Hd Cap (Flg)	10	M14-2.0 x 119
4	Ring Dowel	10	
5	Bushing, Cam	1	
6	Plug, Expansion	2	1.0 in.
7	Plug, Expansion	4	
8	Plug, Expansion	3	.70 in.
9	Plug, Expansion	1	Not used with Turbocharger
10	Tube, Turbo Oil Drain	1	
11	Plug, Expansion	1	3/8 in.
12	Plug, Expansion (Welch)	1	2.37 in.
13	Pin, Dowel	2	
14	Ring, Dowel	2	
15	Ring, Dowel	2	
16	Nozzle, Piston Cooling	4	
17	Plug, Pipe	2	1/8 NPTF
18	Plug, Pipe	1	1/2 NPTF (N/A Only)
19	Plug, Expansion	1	Use w/o side oil fill
20	Seal, Rectangular Ring	1	
21	Tube, Oil Filler	1	
22	Screw, Hex Head Cap	2	M12-1.75x25
23	Cap, Filler	1	
24	Rod, Connecting	4	6 for 6B
25	Cap, Connecting Rod	4	6 for 6B
26	Bolt, Connecting Rod	8	12 for 6B
27	Bearing, Connecting Rod	8	12 for 6B
28	Bushing	4	6 for 6B
29	Piston	4	6 for 6B
30	Pin, Piston	4	6 for 6B
31	Ring, Retaining	8	12 for 6B
32	Ring, Piston (Top)	4	6 for 6B
33	Ring, Piston (Mid)	4	6 for 6B
34	Ring, Piston (Oil)	4	6 for 6B
35	Crankshaft	1	
36	Gear, Crankshaft	1	
37	Pin, Dowel	1	
38	Bearing, Main (Lower)	5	7 for 6B
39	Bearing, Main (Upper)	4	6 for 6B
40	Bearing, Main (Thrust)	1	
41	Camshaft	1	
42	Gear, Camshaft	1	
43	Key	1	
44	Support, Cam Thrust	1	

Item	Part Name	Qty.	Remarks
45	Screw, Hex Hd Cap	2	M8-1.25x20
46	Housing, Balancer	1	
47	Bearing, Needle	2	
48	Bearing, Needle	2	
49	Bearing, Needle	2	
50	Shaft, Balancer	1	
51	Shaft, Balancer	1	
52	Race, Inner Bearing	6	
53	Pin	8	
54	Key	2	
55	Gear, Balancer Shaft	1	
56	Gear, Balancer Shaft	1	
57	Weight, Balancer Counter	3	
58	Screw, Hex Head	10	
59	Collar, Thrust	2	
60	Plate, Thrust Bearing	1	
61	Plate, Thrust Bearing	1	
62	Screw, Hex Head	2	
63	Gear, Idler	1	
64	Bearing, Needle	1	
65	Retainer, Gear	1	
66	Screw, Socket Head	2	
67	Gasket, Gear Cover	1	
68	Housing, Gear	1	
69	Gasket, Gear Housing Cover	1	
70	Gear Cover	1	
71	Screw, Hex Head (Flange)	4	M8-1.25x50
72	Screw, Hex Head (Flange)	16	M8-1.25x16
73	Screw, Hex Head (Flange)	7	M8-1.25x50
74	Seal, Rectangular Ring	1	
75	Cover, Access Hole	1	
76	Plate, Data	1	
77	Screw, Drive	2	
78	Plate, Data	1	
79	Screw, Drive	2	
80	Seal, Rectangular Ring	1	
81	Housing, Timing Pin	1	
82	O-Ring	1	
83	Pin, Timing	1	
84	Ring, Retaining	1	
85	Screw, Round Hex (Torx)	2	M5-0.8x17
86	Seal, Front Crank	1	
87	Pulley, Crankshaft	1	
88	Screw, Hex Head (Flange)	4	M12-1.25x36

## Cylinder Block - General Information

The B-Series engine is available in 4 cylinder or 6 cylinder versions.

Most parts are common between the 4 and 6 cylinder versions (e.g. pistons, rings, connecting rods, water pump).

In general, the only parts that differ between the 4 and 6 cylinder versions are those that must change due to the difference in number of cylinders (e.g. crankshaft, block casting, cylinder head, etc).

### Camshaft:

The camshaft end clearance is determined by the clearance between the camshaft and the thrust plate.

Camshafts that are damaged or worn on the fuel transfer pump lobe or valve lobes must be replaced. Cummins Engine Company, Inc. does not recommend the grinding of camshaft lobes.

### Crankshaft:

The crankshaft is a balanced, forged steel, full fillet hardened unit. The 4 cylinder crankshaft has 5 main bearing journals and the 6 cylinder crankshaft has 7 main bearing journals. All of the upper main bearing shells are the same except for the next to last journal which uses a flanged upper bearing shell. The flanges on the upper bearing shell control the end thrust of the crankshaft.

Oversize main bearings, thrust bearings, and connecting rod bearings are available for service. Cummins Engine Company, Inc. recommends regrinding ALL of the main bearing or the connecting rod journals when ONE requires regrinding.

### Cylinder Block

The cylinder block has provisions for the oil cooler housing, thermostat seats, coolant bypass line, water pump volute, oil pump housing, water pump inlet, and bored piston cylinders with spacing between cylinders to provide room for dry liners, if needed for service.

### Oil Seals

All crankshaft seals on the B Series are Teflon lay-down lip (scroll) type. The Teflon lay-down lip type seal does not contain a spring on the back of the sealing lip. The sealing lip is a thin, stiff piece of Teflon.

Teflon seals must be dry before installation. Do not lubricate the seal lip or the shaft.

After the first few turns of the shaft, a thin film of Teflon is transferred from the seal lip to the shaft. If the shaft or seal is not clean and dry, this transfer will not occur and the seal will leak.

### Pistons

The pistons have a cast aluminum body and 3 ring grooves. The top ring groove on turbocharged engines has a ni-resist insert with a Keystone profile. The pistons for different engine configurations are similar in appearance, but are not interchangeable. Always check the part number to be sure the correct piston is used during piston replacement.

### Vibration Damper

Six cylinder engines are equipped with a vibration damper to control the torsional vibration of the crankshaft. A vibration damper is engineered for use on a specific engine model.

It is not economical to repair a vibration damper in the field. Install a new or a rebuilt damper if inspection indicates the damper is defective.

### Cylinder Block - Service Tools

The following special tools are recommended to perform procedures in Group 01. The use of these tools is shown in the appropriate procedure. These tools can be purchased from your local Cummins Authorized Repair Location.

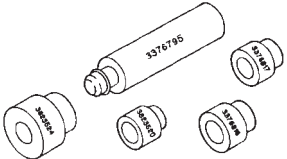
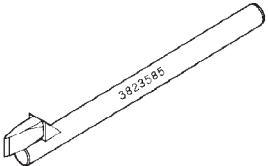
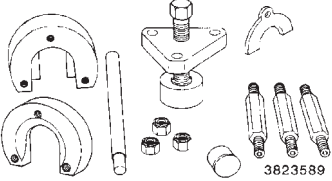
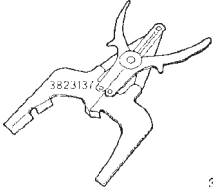
Tool No.	Tool Description	Tool Illustration
<p><b>3823524</b> <b>3823520</b></p>	<p><b>Cup Plug Driver</b></p>	 <p>3376796</p>
<p><b>3823585</b></p>	<p><b>Gear Splitter (for use on pre-1991 engines).</b></p>	 <p>3823585</p>
<p><b>3823589</b></p>	<p><b>Camshaft Gear Installation Kit</b></p>	 <p>3823589</p>
<p><b>3823137</b></p>	<p><b>Piston Ring Expander</b></p>	 <p>3823137</p>

### Cylinder Block Group Inspection Checklist

- Head Deck Flatness .....□
- Main Bearing Bore Diameter.....□
- Camshaft Bore Diameter.....□
- Tappet Bore Diameter .....□
- Build Up of Deposits in the Coolant Passages .....□
- Crankshaft Seal Wear Surfaces .....□
- Rod and Main Journal Scoring.....□
- Vibration Damper Index Line and Rubber Member .....□
- Visually Inspect Piston Assemblies for Damage .....□
- Measure the Piston Skirt Diameter.....□
- Piston Ring Clearance .....□
- Measure the Piston Pin Bore .....□
- Visually Inspect the Connecting Rod Assembly.....□
- Connecting Rod Pin Bore Diameter .....□
- Main Bearing Clearance .....□
- Connecting Rod Bearing Clearance .....□

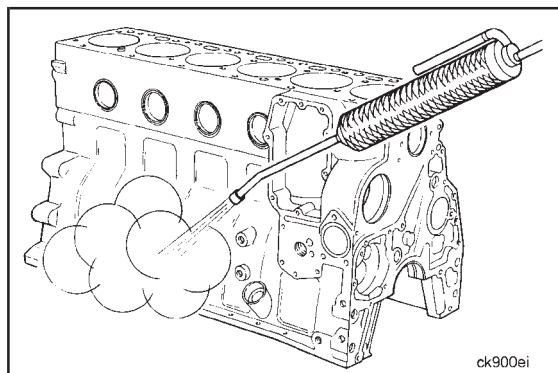

### Cylinder Block - Precheck Before Disassembly (1-01)

Thoroughly clean the cylinder block with steam.

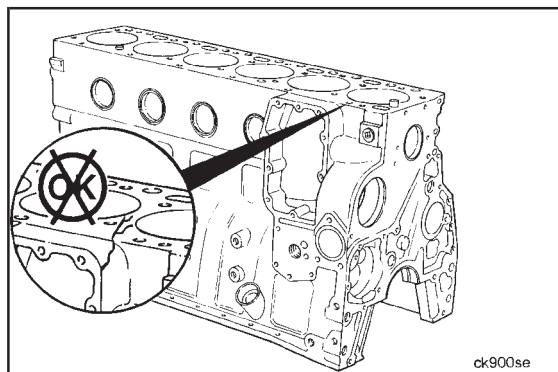

Visually inspect the cylinder block for damage that would prohibit reuse.

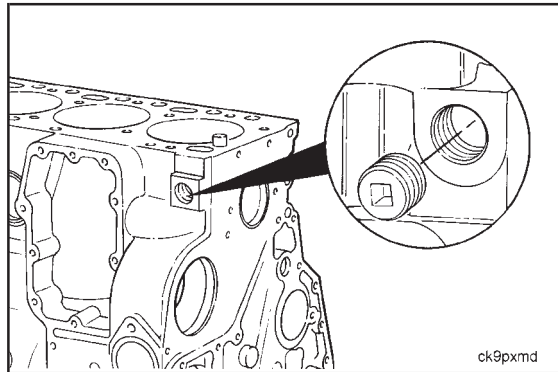

### Cylinder Block - Disassembly (1-02)

**3/8 Inch Square Drive**

Remove the pipe plug from the water passage.

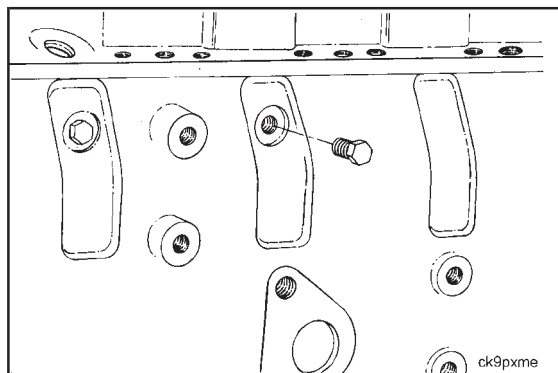

**11 mm**

Remove the pipe plugs from the oil passages.



**Drill Motor, 3mm [1/8 inch] drill bit, Slide Hammer, No. 10 Sheet Metal screw.**

Drill a 3mm [1/8 inch] hole and use a slide hammer equipped with a No. 10 sheet metal screw to remove expansion plugs.

Remove the expansion plugs from the oil passages.

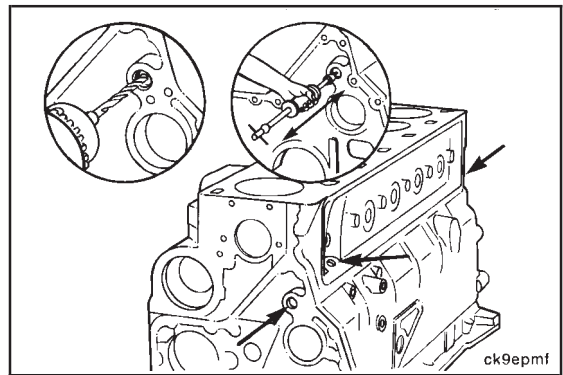

**Punch, Visegrips®, Hammer**

Remove the large expansion plugs (58.06 mm [2.29 in.]) from the coolant passages.

Care should be taken not to drive the expansion plug into the water jacket, especially the plug on the end of the block.

Service Tip: If it becomes apparent the cup plug is not going to pivot in the bore, use a center punch to catch the edge of the cup plug and pry against the block to pivot the plug out.

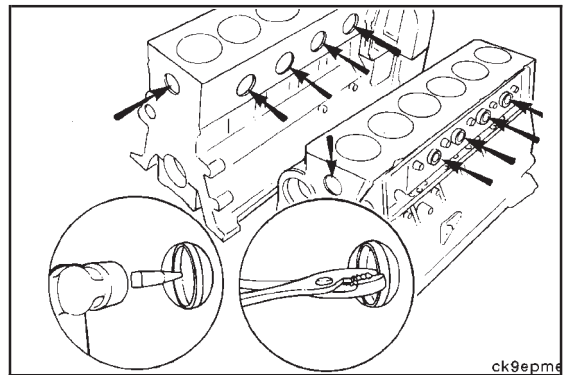

**Hammer, Punch**

Remove the small expansion plugs (25.07 mm [1 in.]) by driving the plugs into the water jacket.

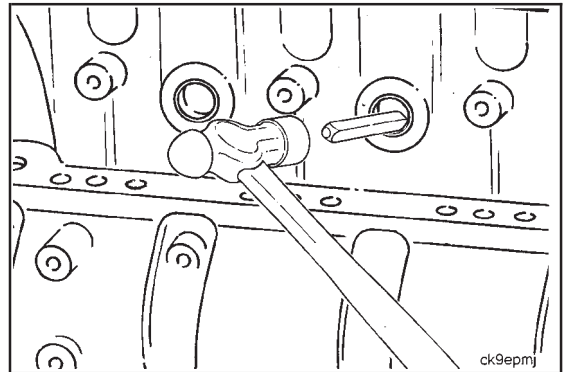

**Mechanical Fingers**

Retrieve the plugs through the water passages in the top of the block.

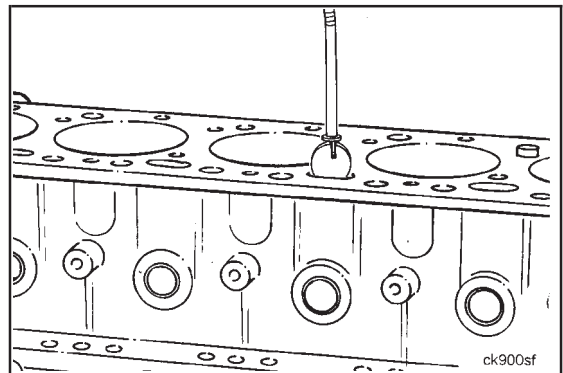



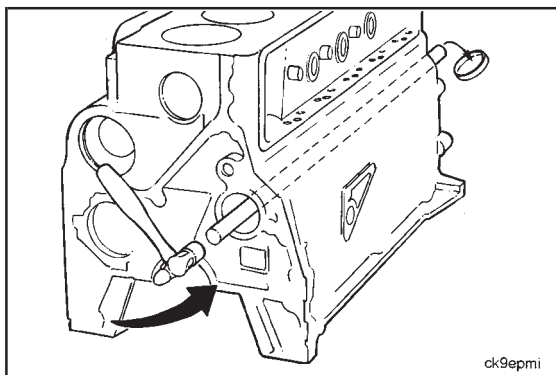

Remove the expansion plug from the camshaft bore.

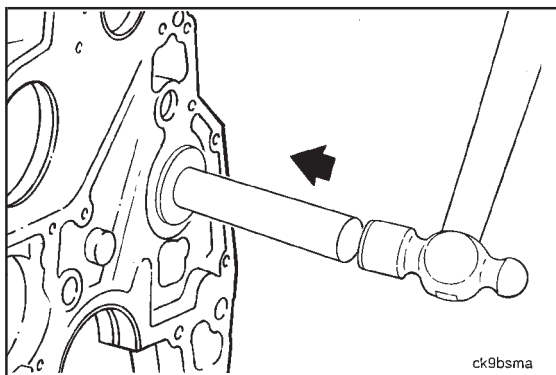

**Universal Bushing Installation Tool**

Remove the camshaft bushing.

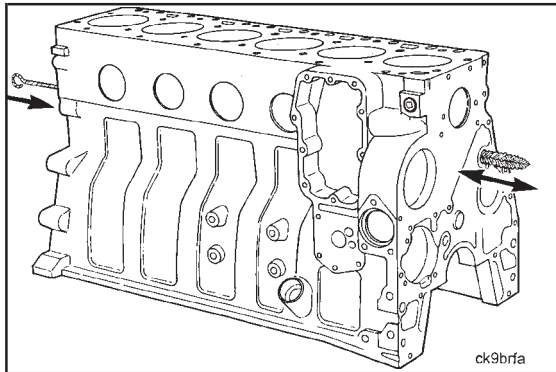

**Cylinder Block - Cleaning (1-03)**

Use clean solvent and a brush to clean the main oil drilling.

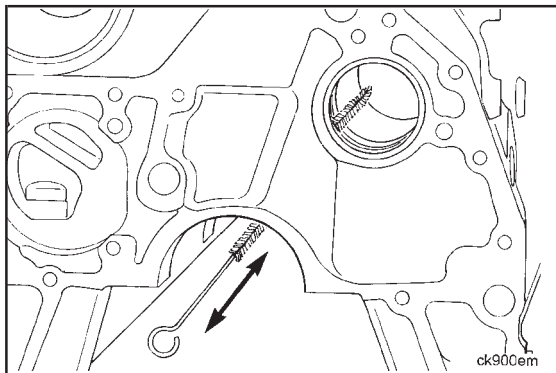

Use clean solvent and a brush to clean the main bearing to cam bore oil drilling.

Use clean solvent and a brush to clean the piston cooling nozzle bores.

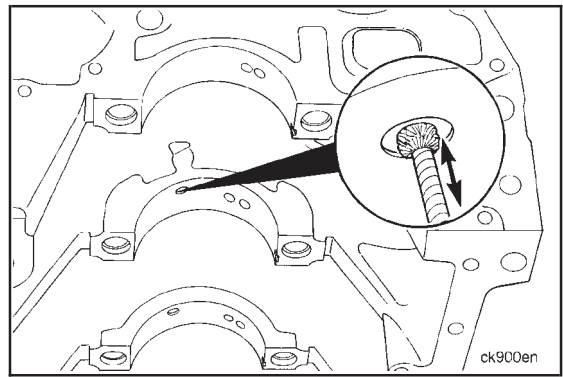

Use clean solvent and a brush to clean the main oil rifle to overhead oil drilling.

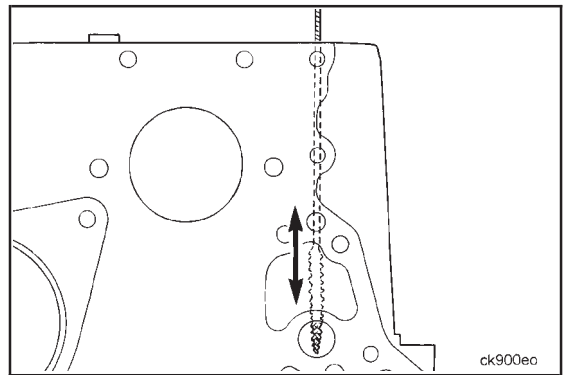

Use clean solvent and a brush to clean the oil cooler oil passages.

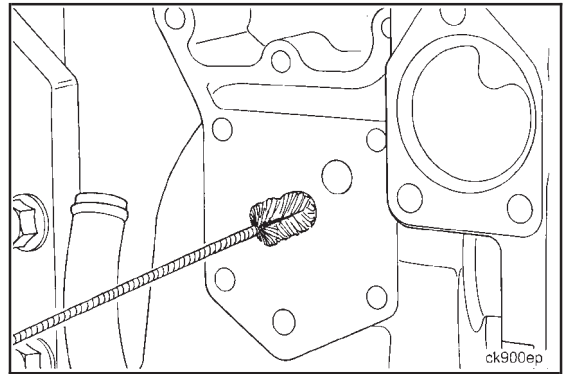

**Gasket Scraper**

Thoroughly clean all gasket sealing surfaces.

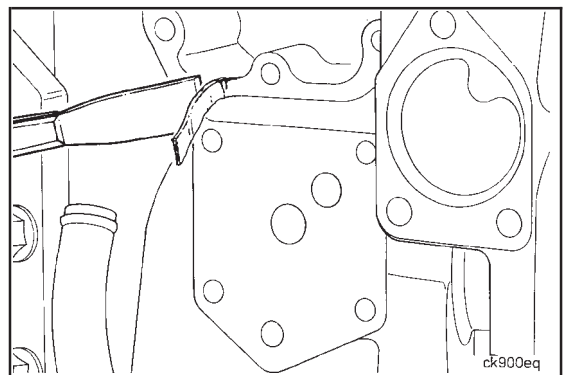

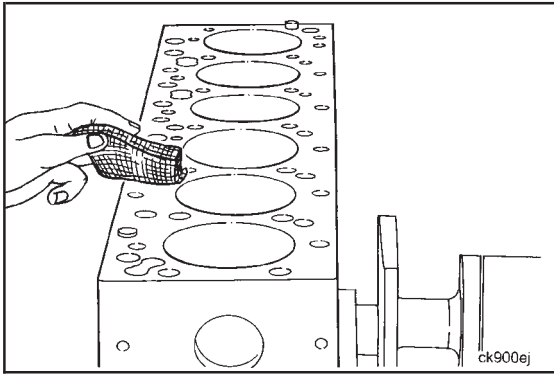

Clean the combustion deck with a Scotch-Brite® cleaning pad or equivalent and diesel fuel or solvent.

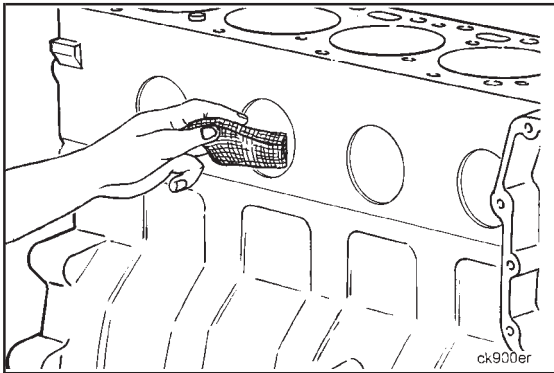

**Brush, 400 Grit Sandpaper, Diesel Fuel**

Thoroughly clean all cup plug holes.

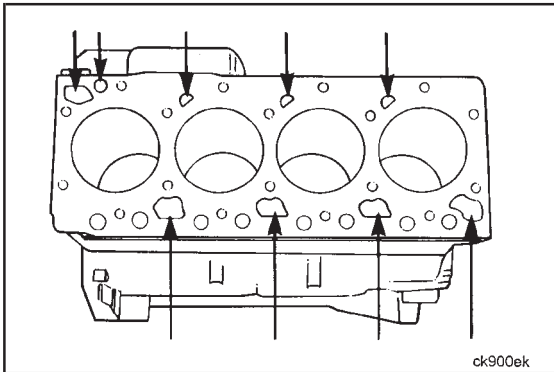

**Caution: Excessive deposits may be cleaned in an acid tank, but the cam bushing must first be removed.**



Build-up of deposits in the coolant passages can cause engine overheating.

Be sure the coolant passages are clean.

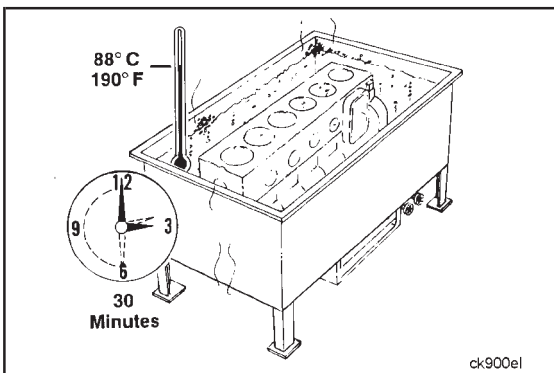

**Warning: Use protective measures to prevent personal injury.**



The block may be cleaned in a hot tank using a soap and water solution without removing the cam bushing.

After rinsing with clean solvent, use compressed air to dry the block.

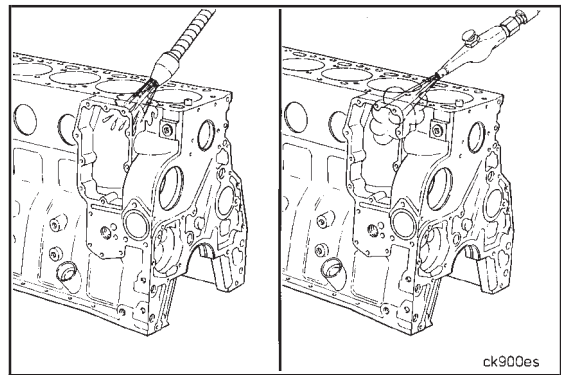

### Cylinder Block - Inspection (1-01)

Inspect the cylinder bores for glazing.

A surface without glaze will have a crosshatched appearance with the lines at 25 to 30 degree angles with the top of the cylinder block.

If de-glazing is required, refer to procedure number (1-05).

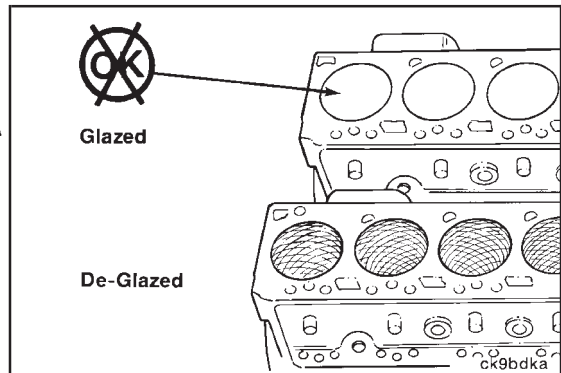

Inspect the cylinder bores for damage or excessive wear.  
Measure the cylinder bores.



Diameter		
mm		in
102.000	MIN	[4.0161]
102.116	MAX	[4.0203]

**Out-of-Roundness:** .038 mm [.0015 in]

**Taper:** 0.076 mm [.003 in]

Oversize pistons and rings (0.5 mm and 1.0 mm oversize) are available for re-bored cylinder blocks.

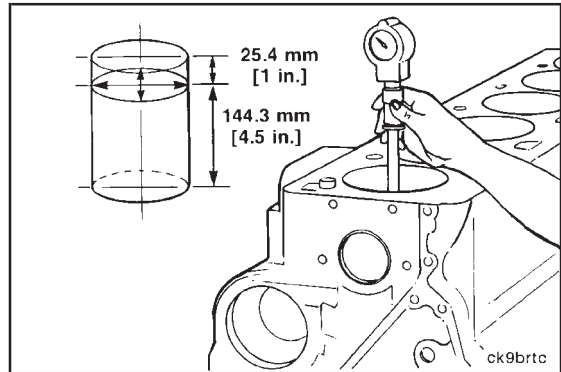

Measure the cylinder block overall flatness:

End-to-End 0.076 mm [0.003 in.]

Side-to-Side 0.051 mm [0.002 in.]

Visually inspect for any localized dips or imperfections. If present, the cylinder head deck must be reground.

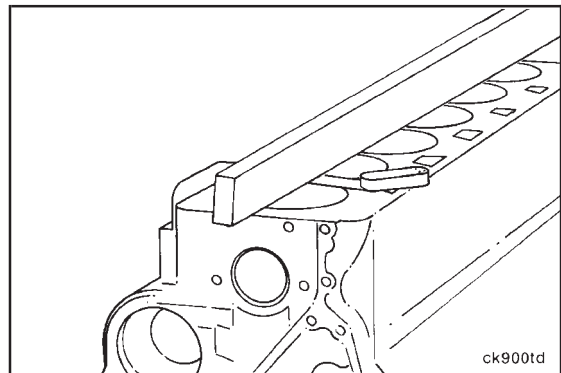

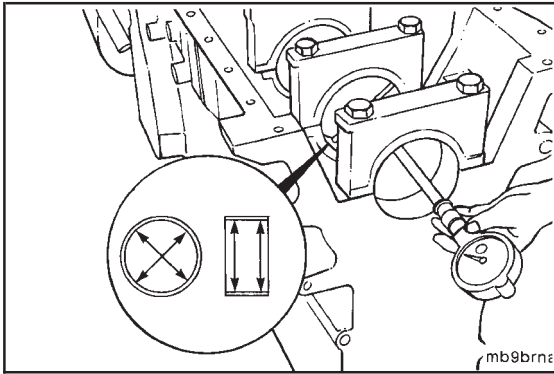

Inspect the main bearing bores for damage or abnormal wear.



Install the main bearings and measure main bearing bore diameter with main bolts tightened to 176 N•m [130 ft-lb].



**NOTE:** Record this measurement for use in determining main bearing clearance as described in procedure (1-12).

Diameter		
mm		in
83.106	MAX	3.2720

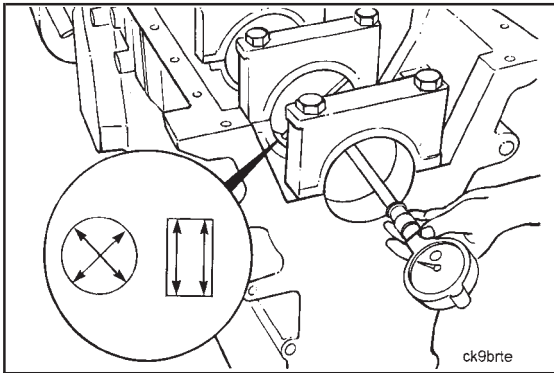

Remove the bearing and install the main bearing cap. Torque the main bearing capscrews to 176 N•m [130 ft-lb]. Measure the main bearing bore with the bearing removed.



Diameter		
mm		in
87.983	MIN	3.4639
88.019	MAX	3.4653

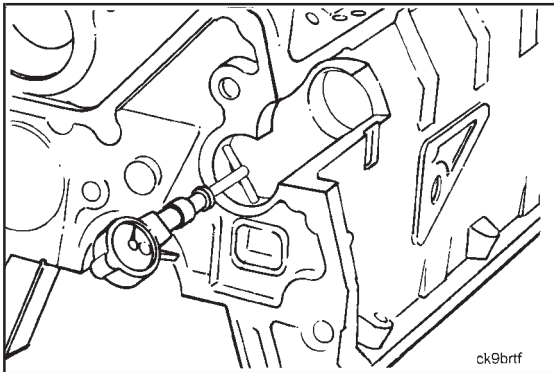

Inspect the camshaft bore without the bushing for scoring or excessive wear.

Diameter No. 1		
mm		in
57.222	MIN	2.2528
57.258	MAX	2.2543

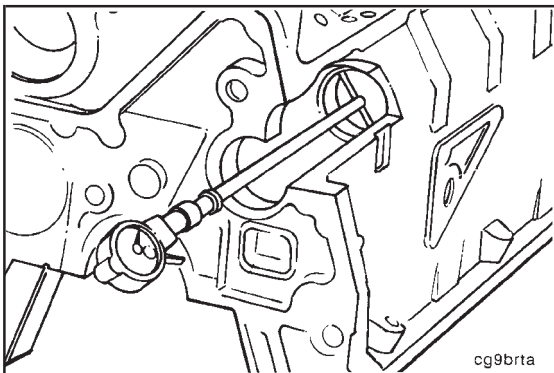

Measure the diameter of camshaft bores No. 2 through No. 5.

Diameter No. 2-5		
mm		in
54.089	MIN	[2.1295]
54.164	MAX	[2.1324]

Service bushings are available and must be used if wear exceeds above dimensions.

Inspect the tappet bores for scoring or excessive wear.



Diameter		
mm		in
16.000	MIN	[0.630]
16.055	MAX	[0.632]

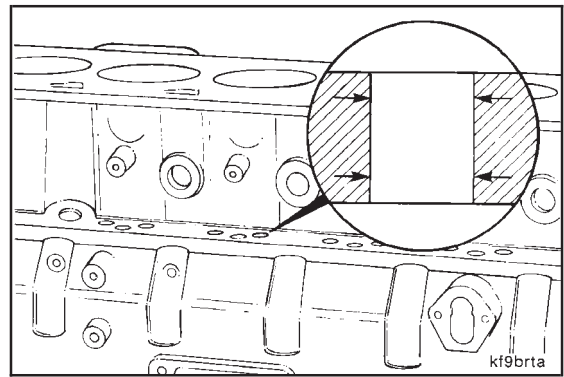

**NOTE:** If the cylinder head or cylinder block is out of specification, the out of specification surface must be machined. Refer to the Alternative Repair Manual, Bulletin No. 3666109, for re-surfacing information.



### Cylinder Block - De-Glazing (1-05)

New piston rings may not seat in glazed cylinder bores.

De-glazing makes the bore "rough" to help seat the rings. The size of the bore is not changed by proper de-glazing.

Improper de-glazing will change the size of the bore.

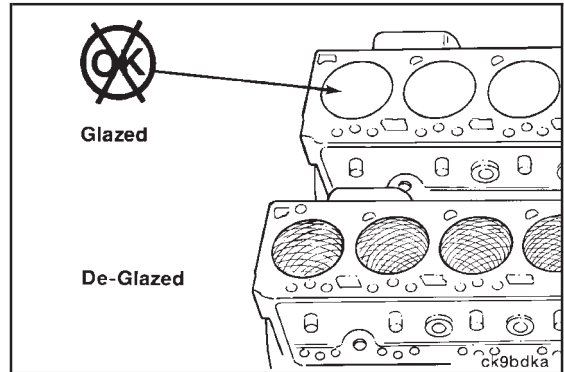

A correctly de-glazed surface will have a crosshatched appearance with the lines at 15 to 25 degree angles with the top of the cylinder block.

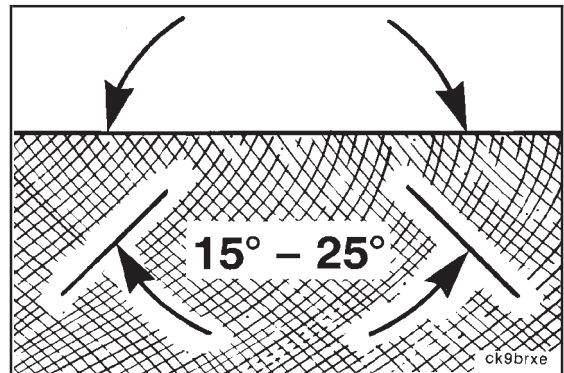

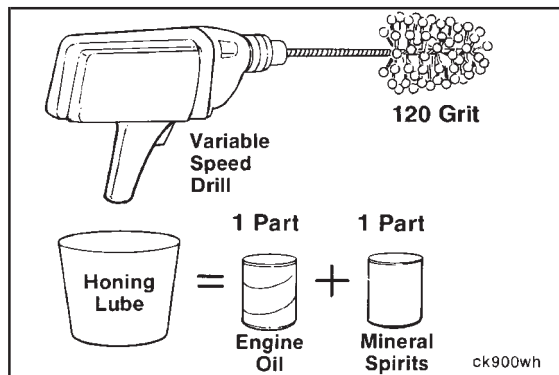

Use a drill, a medium grit Flexi-Hone and a mixture of equal parts of diesel fuel and SAE 30W engine oil to de-glaze the bores.

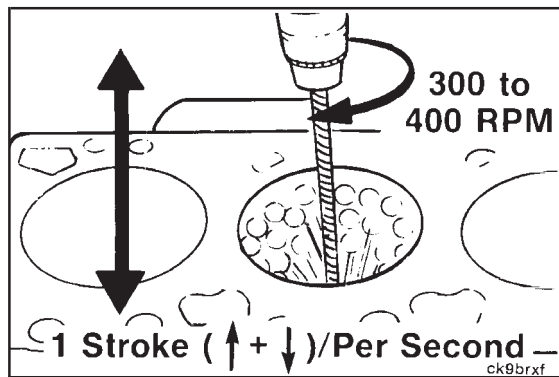

The crosshatch angle is a function of drill speed and how fast the hone is moved vertically.

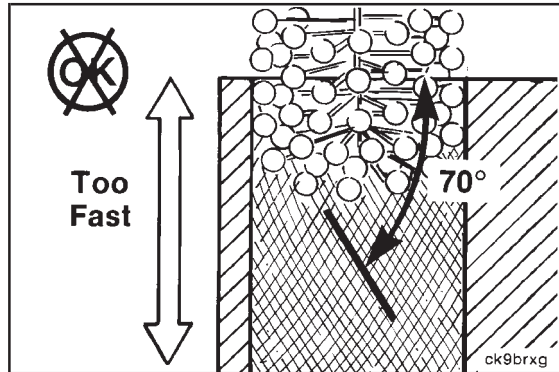

This illustration shows the result of the drill speed is too slow or the vertical stroke is **too fast**.

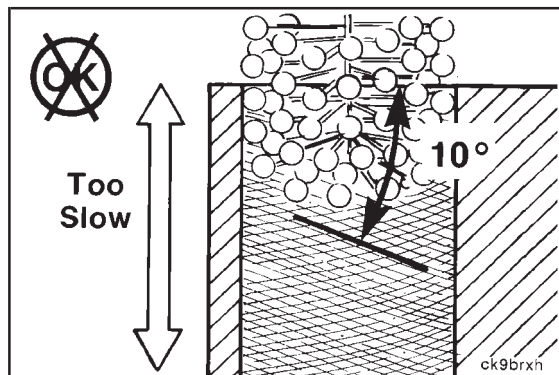

This illustration shows the result of the drill speed is too fast or the vertical stroke is **too slow**.

**NOTE:** Vertical strokes must be smooth continuous passes along the full length of the bore.

Inspect the bore after 10 strokes.

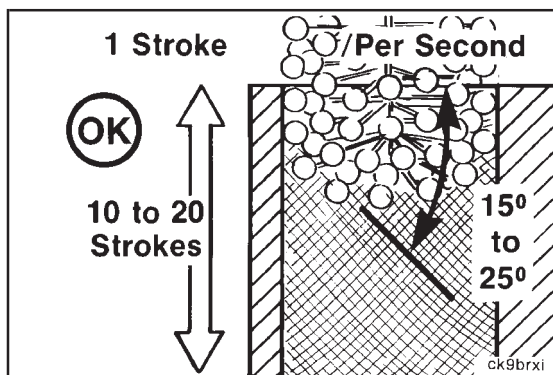

**Caution:** Be extremely careful not to hone the bore out of specification.

A sizing hone can be used to remove minor grooves or to correct minor out of taper.

Taper: 0.076 mm [0.003 in]

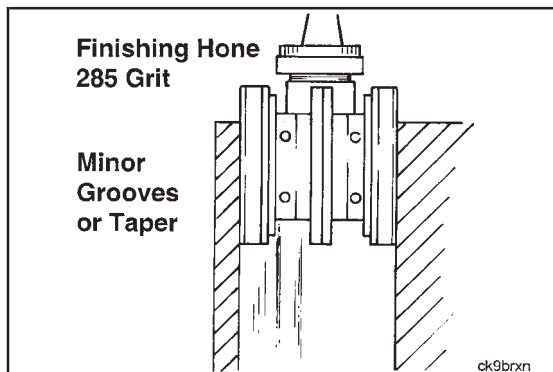

Operate the sizing hone similarly to the Flexi-Hone.

Inspect the bore after 10 strokes.

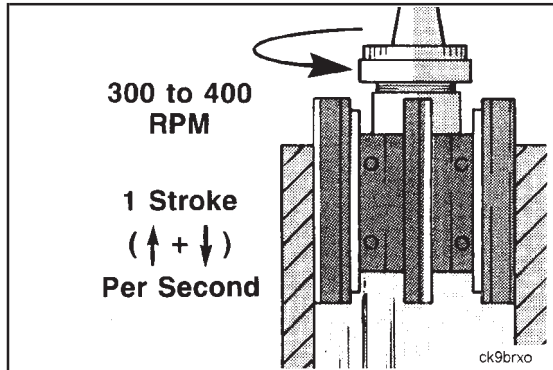

Immediately clean the cylinder bores with a strong solution of laundry detergent and hot water.

After rinsing, use compressed air to dry the block.

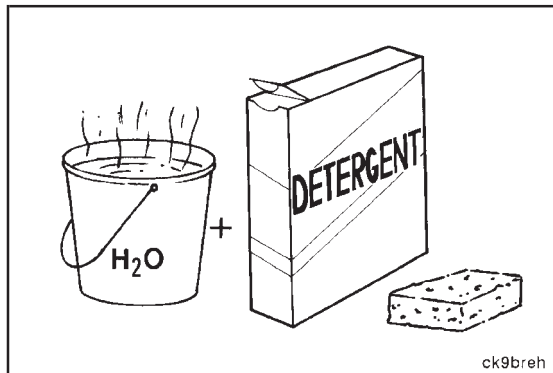



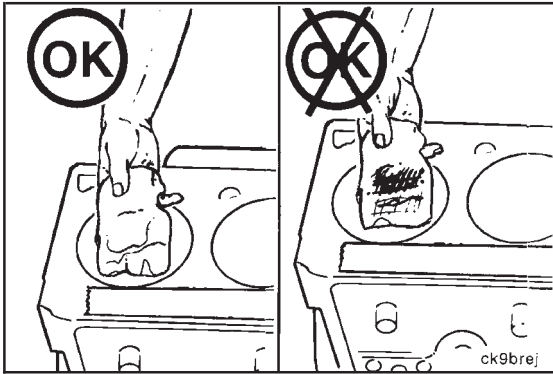

Check the bore cleanliness by wiping with a white, lint free, lightly oiled cloth. If grit residue is still present, re-clean.

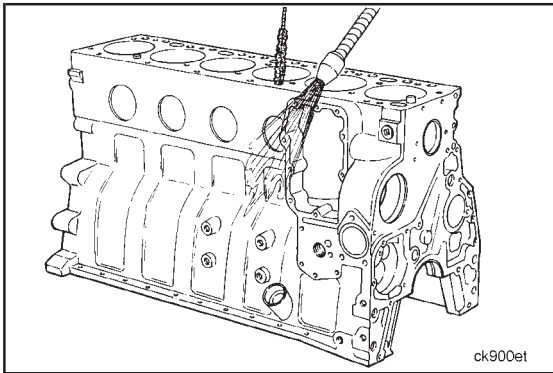

Wash the block in solvent.  
Use a brush to clean all oil passages.

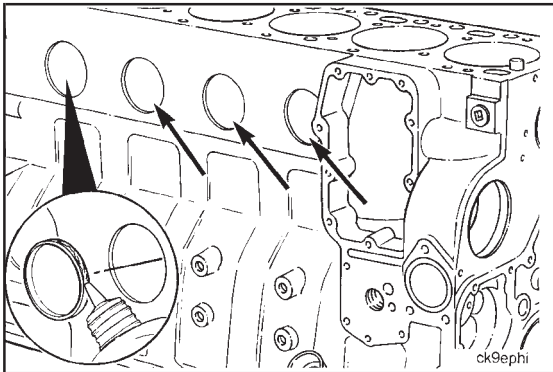

### Expansion and Pipe Plug - Installation (1-06)

All expansion plug bores in the block are machined to a standard english dimension (i.e., 11/16 in, 1-1/4 in, etc.).

To achieve the correct press fit of the expansion plug in the bore, the expansion plug must be larger than the bore diameter and the expansion plug driver must be smaller than the bore diameter. Therefore, expansion plugs and their drivers are not made to a standard english dimension.

The plug drivers are called out by the dimension of the bore they are to be used on (i.e., a 1 in driver for 1" bore). The expansion plugs are called out by Cummins part number (a dimension is also listed for reference).

Apply a bead of Three Bond, Part No. 3823494, around the outside diameter of all expansion plugs before installing.

Drive all expansion plugs in until the outer edge is flush with the counter sink in the block.

Refer to procedure (1-07) for camshaft expansion plug installation.

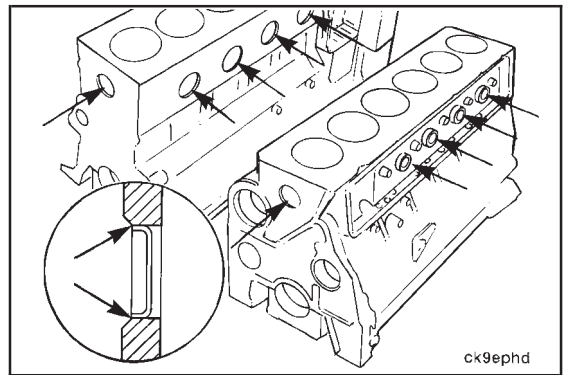

ck9ephd

Apply a film of pipe plug sealant, Part No. 3375066, or equivalent, to the threads.

Install and tighten the pipe plugs.

Refer to the following chart for torque values.

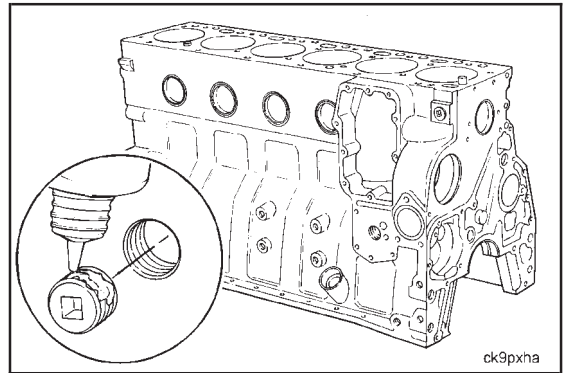

ck9pxha

Tighten pipe plugs to the appropriate torque values.



Pipe Plug Torque Values						
Thread	Size		Torque		Torque	
	Actual Thread O.D.		In Aluminum Components		In Cast Iron or Steel Components	
in.	mm	[in]	N•m	[ft-lbs]	N•m	[ft-lbs]
1/16	8.1	[0.32]	5	[45 in-lb]	15	[10]
1/8	10.4	[0.41]	15	[10]	20	[15]
1/4	13.7	[0.54]	20	[15]	25	[20]
3/8	17.3	[0.68]	25	[20]	35	[25]
1/2	21.6	[0.85]	35	[25]	55	[40]
3/4	26.7	[1.05]	45	[35]	75	[55]
1	33.5	[1.32]	60	[45]	95	[70]
1 1/4	42.2	[1.66]	75	[55]	115	[85]
1 1/2	48.3	[1.90]	85	[65]	135	[100]

ck8ppoa

**Driver Part No. 3823524 (Coolant Passages), Part No. 3823520 (Oil Rifle)**

Expansion plug locations. Front of block.

1. Expansion Plug Part No. 3900965 (58.06 mm)
2. Expansion Plug Part No. 3900956 (17.73 mm)

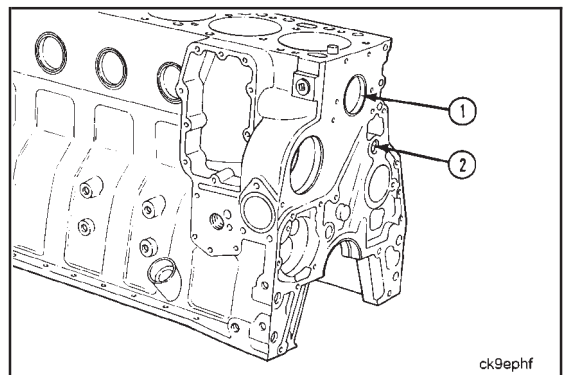

ck9ephf

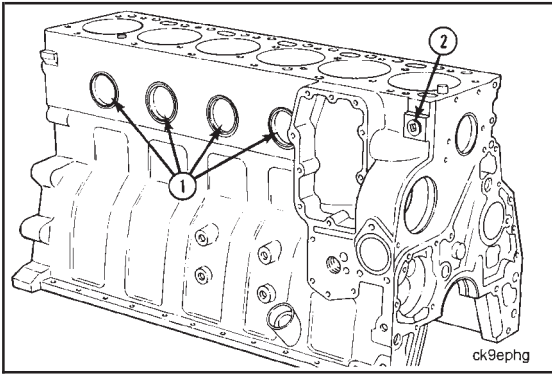

**Driver Part No. 3823524 (Coolant Passages)**

Pipe plug and cup plug locations. Right side of block.



1. Expansion Plug Part No. 3812090 (58.06 mm)
2. Pipe Plug, 0.50 in (1/2 in)

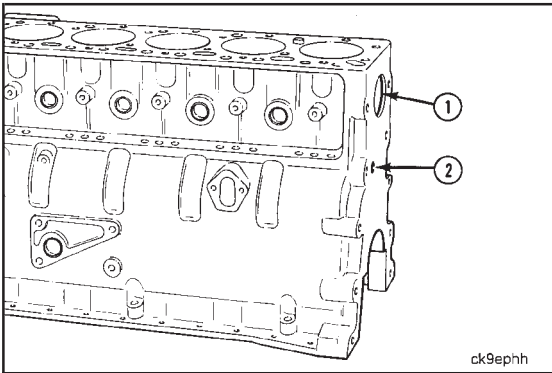

**Driver Part No. 3823524 (Coolant Passages), Part No. 3823520 (Oil Rifle)**

Expansion plug locations. Rear of block.



1. Expansion Plug Part No. 3812090 (58.06 mm)
2. Expansion Plug Part No. 3900956 (17.73 mm)

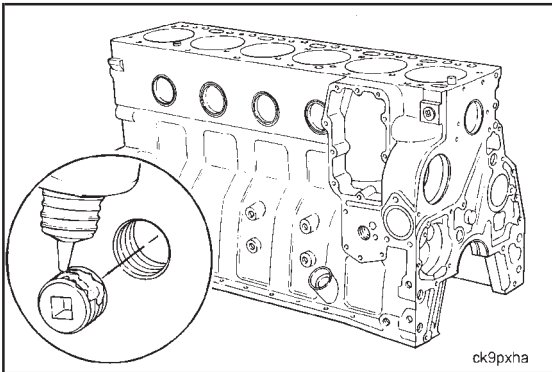

**Driver Part No. 3823520 (Oil Rifle), Part No. 3376816 (Crankcase), Part No. 3376817 (Alternate Oil Fill), Part No. 3822372 (Alternate Dipstick Holes)**

Pipe plug and expansion plug locations. Left side of block.



1. Expansion Plug Part No. 3900956 (17.73 mm)
2. Expansion Plug Part No. 3914035 (25.75 mm)
3. Expansion Plug Part No. 3900955 (9.80 mm)
4. Expansion Plug Part No. 3900958 (32.03 mm)
5. Pipe Plug, 0.125 in (1/8) NPTF Hex Head

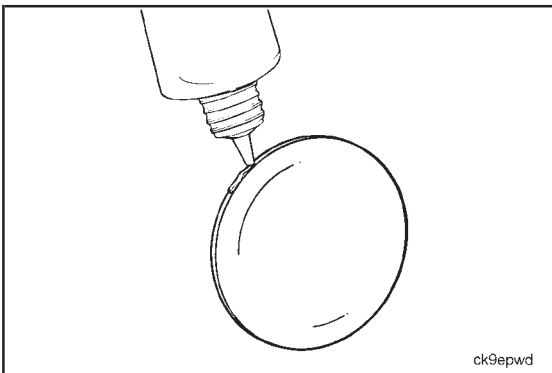

**Camshaft Expansion Plug - Installation (1-07)**

Apply a bead of Three Bond, Part No. 3823494, around the outside diameter of the camshaft expansion plug.

Position the plug with the convex side out.

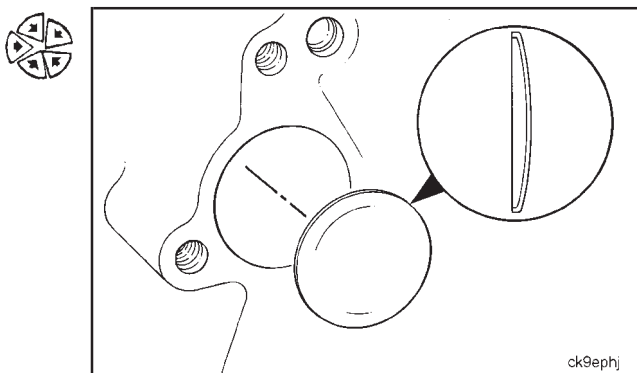

**Large Drift, Hammer**

Expand the plug with a large drift and a hammer.

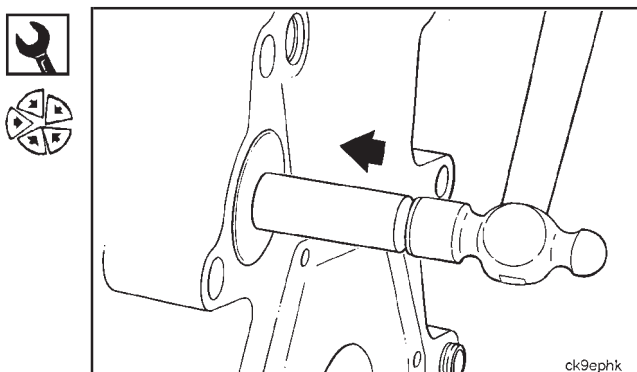

Expand the plug until the convex side is flush with the block.

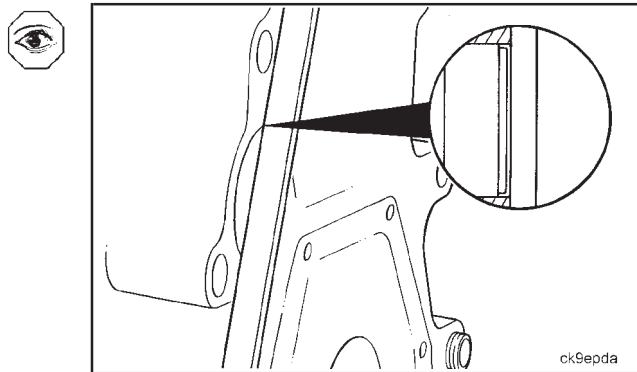

**Camshaft Bushing - Installation (1-08)**

Mark the camshaft bushing and block to align the oil hole.

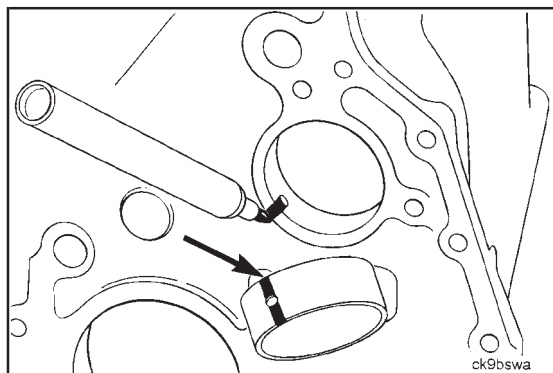

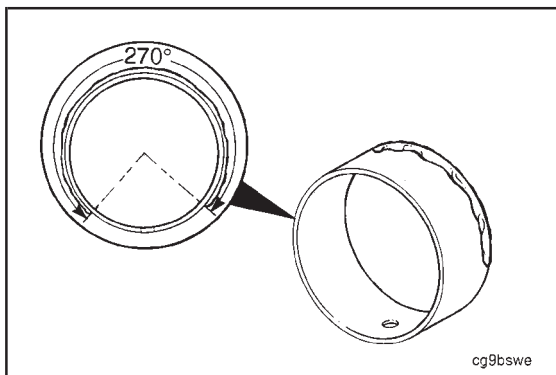

Apply a bead of Loctite™ 609 to the edge of the bushing that will be installed to the rear of the bore. Apply the Loctite™ to 270 degrees of the diameter of the bushing, see the illustration. Use care to not apply Loctite™ near to or in line with the oil hole.

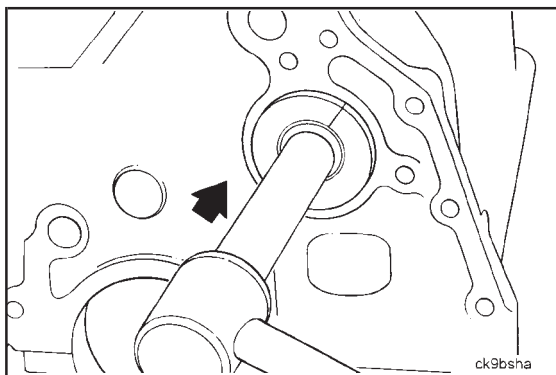

**Universal Bushing Installation Tool**  
Install the camshaft bushing flush with the block.

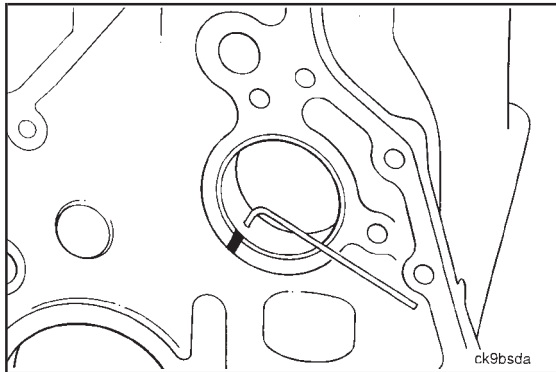

**Be sure the oil hole is aligned.**  
A 3.2mm [0.126 in] diameter rod must be able to pass through the hole.

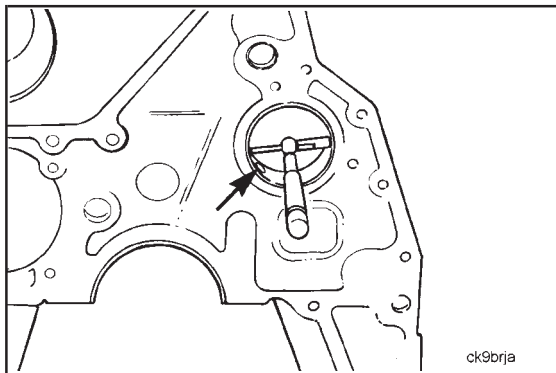

Measure the installed camshaft bushing.

Camshaft Bushing Bore		
mm		in
54.107	MIN	2.1302
54.146	MAX	2.1317

### Dipstick Tube - Replacement (1-09)

#### Pliers

If the dipstick tube is loose or damaged, remove it from the cylinder block.

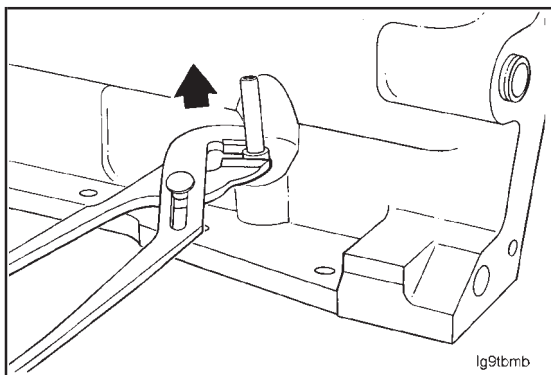

Apply sealant, Part No. 3375068, to the new dipstick tube.

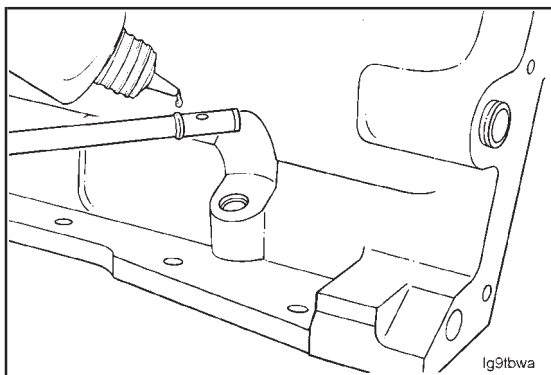

Use a hex head capscrew to drive the tube into the block.

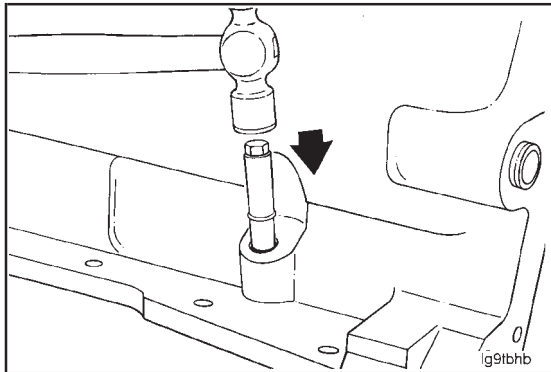

### Cylinder Block - Storing (1-10)

If the block is not to be used immediately, lubricate all surfaces to prevent rusting.

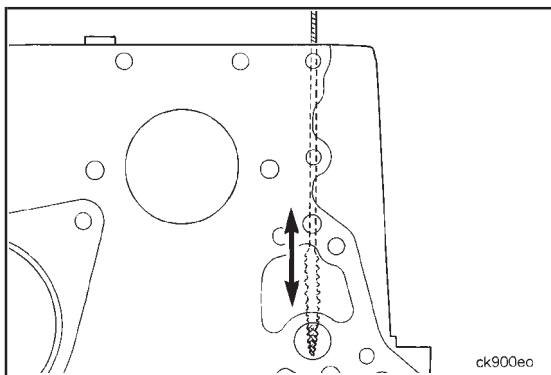

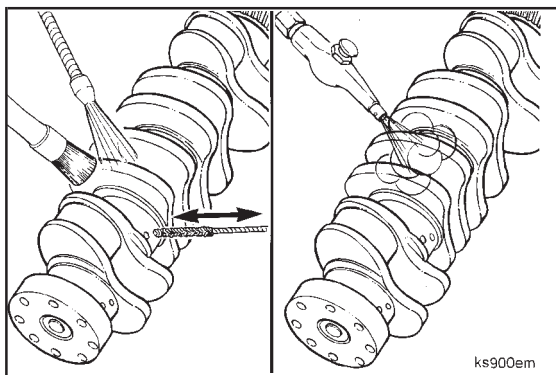

### Crankshaft - Cleaning (1-11)

Clean the crankshaft oil drillings with a brush.  
Rinse in clean solvent and use compressed air to dry.

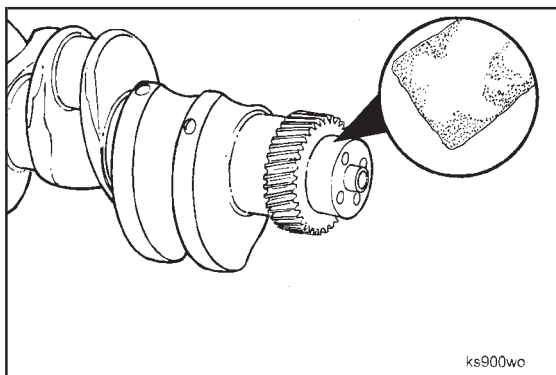

Clean the oil seal wear surfaces with diesel fuel and crocus cloth.

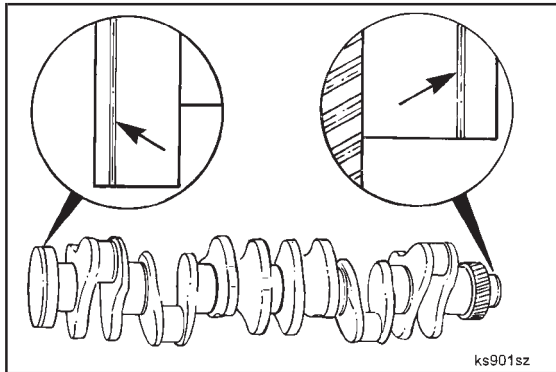

### Crankshaft - Inspection (1-12)

Inspect the crankshaft seals wear surfaces for scratches or grooving.

**If shaft is grooved, install a wear sleeve.**

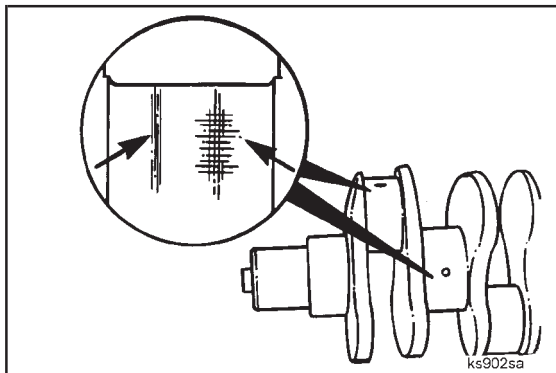

Inspect the rod and main journals for deep scoring, overheating, etc.

**Determining Main Bearing Clearance**

Measure the main journal diameters and determine main bearing clearance.

Main Bearing Journal Diameter		
mm		in
82.962	MIN	3.2662
83.013	MAX	3.2682

**Out-of-Roundness:** 0.050mm [0.002 in]

**Taper:** 0.013mm [0.0005 in]

**Bearing Clearance** = Main Bore Diameter with bearing installed minus (-) Crankshaft Main Journal Diameter.

**Maximum Bearing Clearance:** 0.119mm [0.0047 in]

**Crankshaft Gear - Replacement (1-13)**

Remove the crankshaft gear.

Use a heavy duty puller.

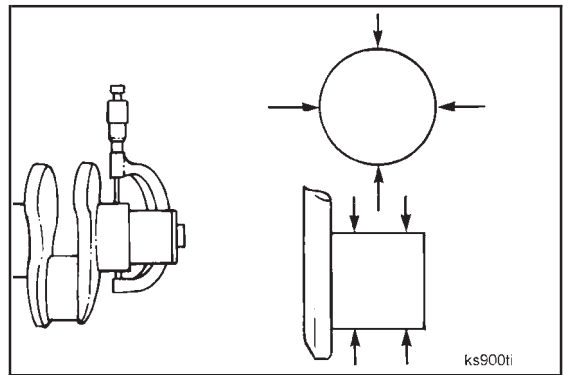

ks900ti

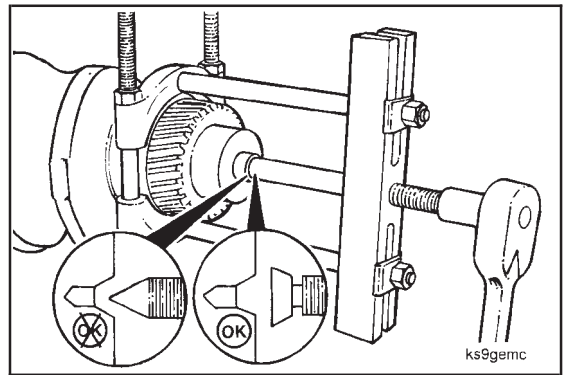

ks9gemc

**2 lb Steel Hammer, Gear Splitter Part No. 3823585**

An optional tool is available to split the crankgear off of Pre-1991 crankshafts.

Service Tip: Always use a large steel hammer when splitting the crankshaft gear. Lead hammers absorb the shock required to break the gear.

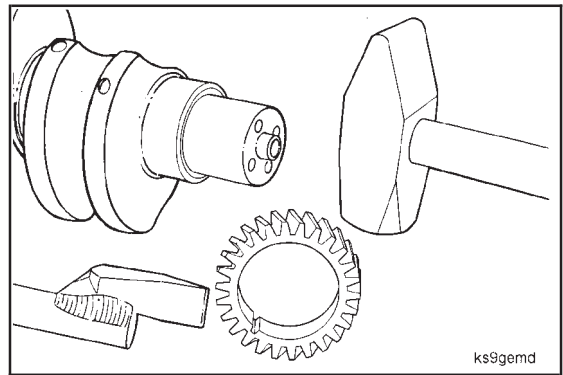

ks9gemd

Remove all burrs and make sure the gear surface on the end of the crankshaft is smooth.

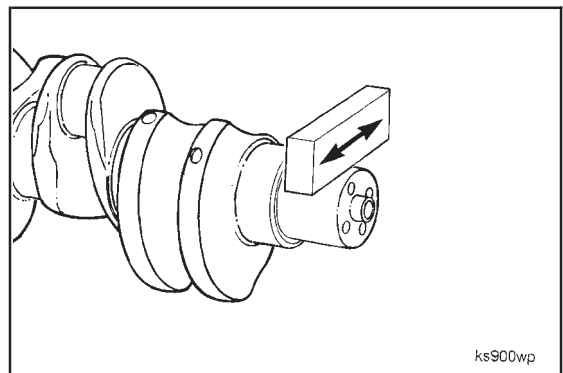

ks900wp



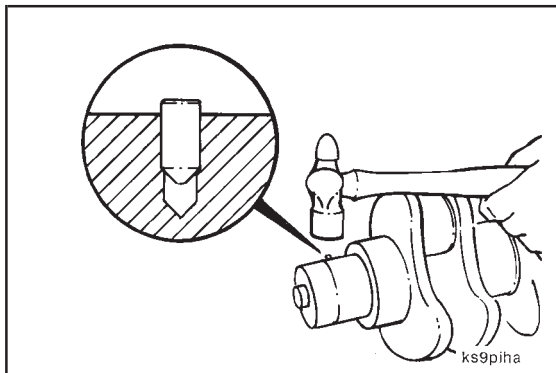

**Hammer**

If previously removed, install the alignment pin until it bottoms.

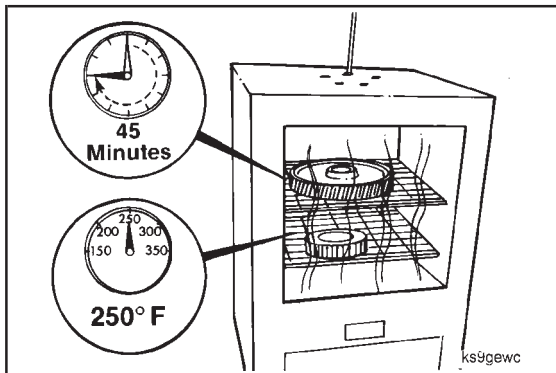

**Caution:** The gear will be permanently distorted if overheated. The oven temperature should never exceed 177°C [350°F].

Heat the crankshaft gear in a preheated oven for 45 minutes at 149° C [300° F].

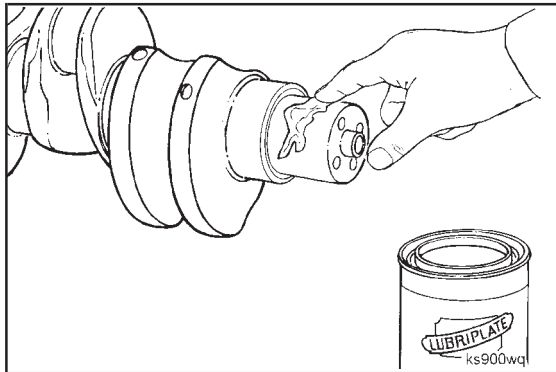

Apply a thin coating of lubricant to the nose of the crankshaft.

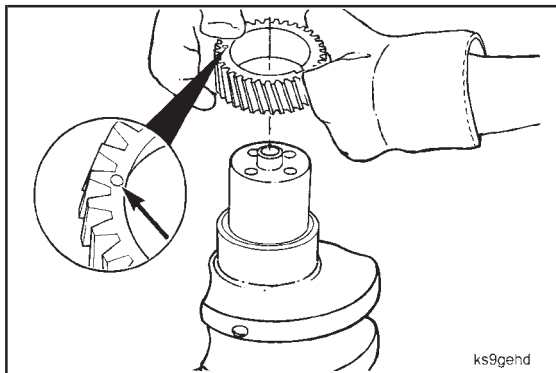

**Warning:** Wear protective gloves to prevent personal injury.

Install the hot gear up to the crankshaft shoulder with the timing mark out.



### Camshaft - Cleaning (1-14)

Wash the camshaft and gear with solvent and a lint free cloth.

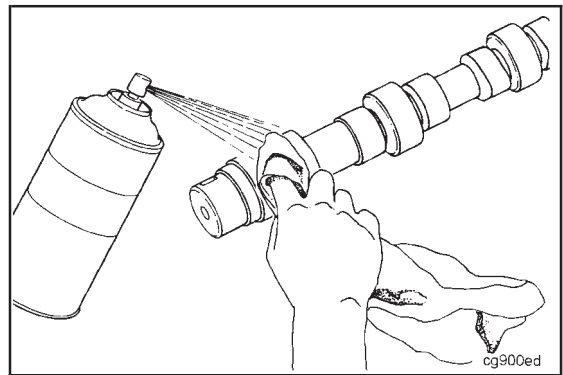

### Camshaft and Gear - Inspection (1-15)

Inspect the lift pump lobe, valve lobes and bearing journals for cracking, pitting or scoring.

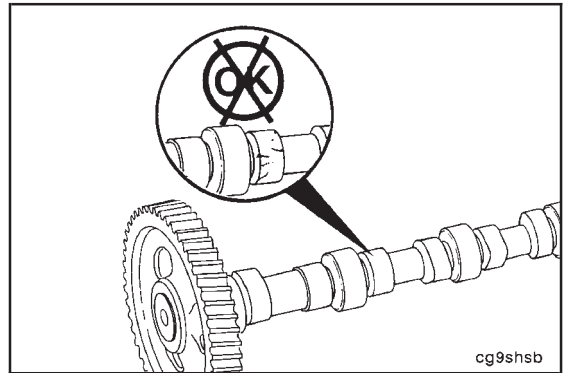

Inspect the gear teeth for pitting; look for cracks at the root of the teeth.

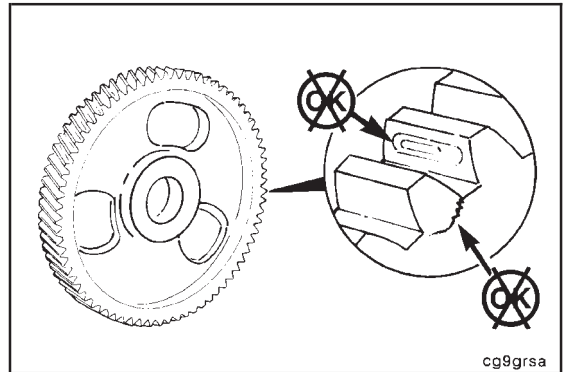

Measure the fuel transfer pump lobe and valve lobes.



	Diameter at Peak of Lobe		in
	mm		
Intake	47.040	MIN	1.852
	47.492	MAX	1.870
Exhaust	46.770	MIN	1.841
	47.222	MAX	1.859
Lift Pump	35.500	MIN	1.398
	36.260	MAX	1.428

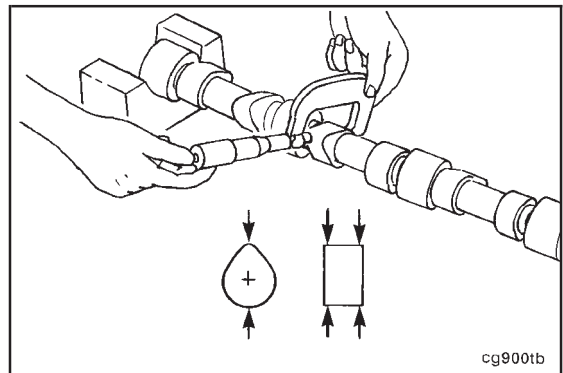

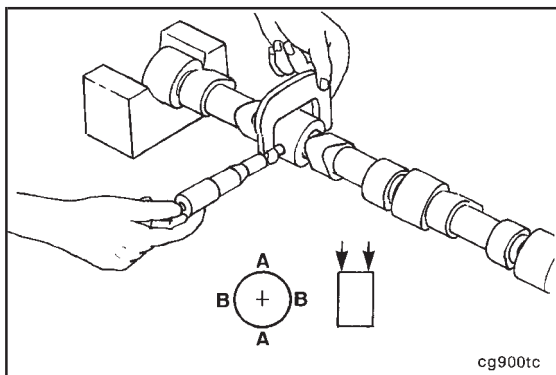

Measure the bearing journals.

Journal Diameter		
mm		in
53.962	MIN	2.1245
54.013	MAX	2.1265

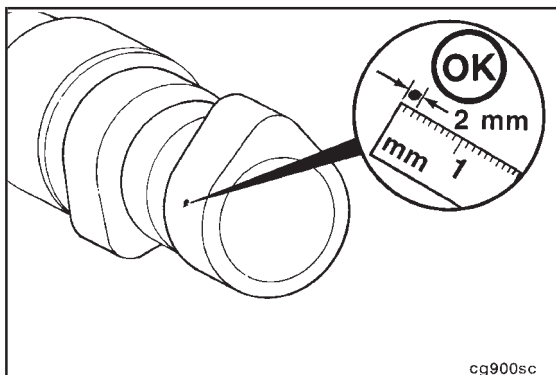

**Camshaft Lobe Pitting Reuse Criteria (1-16)**

A single pit should not be greater than the area of a 2 mm [.079 in] diameter circle.

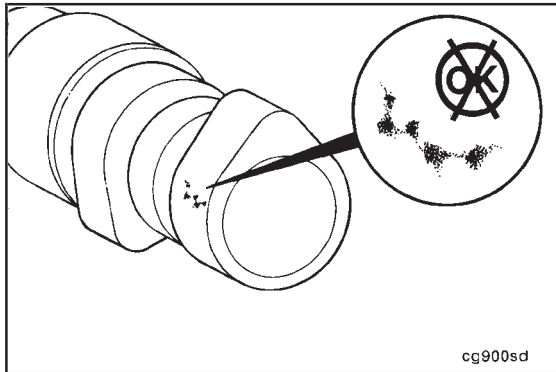

Interconnection of pits is not allowable and is treated as one pit.

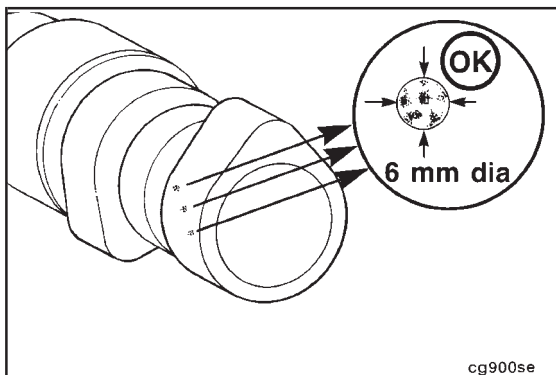

The total pits, when added together, should not exceed a circle of 6 mm [0.236 in].

Only one pit is allowed within + or - 20 degrees of the nose of the cam lobe.

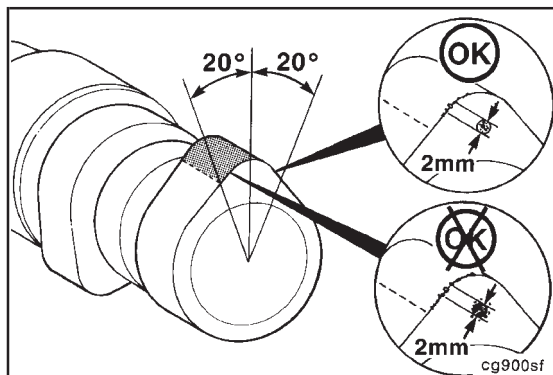

**Camshaft Lobe Edge Deterioration (Break-down) Criteria (1-17)**

The area of edge deterioration should not be greater than the equivalent area of a 2 mm [0.079 in] circle within + or - 20 degrees of the nose of the cam lobe.

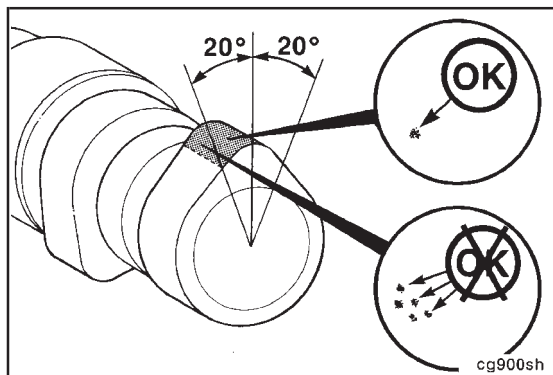

Outside of the + or - 20 degrees of the nose of the cam lobe, the areas of edge deterioration should not be greater than the equivalent area of a 6 mm [0.236 in] circle.

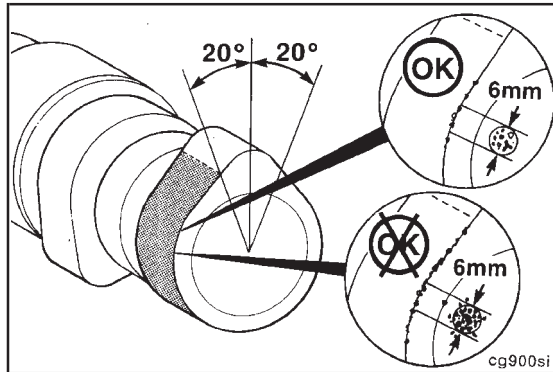

The first of the following illustration shows normal polish and a casting flaw within the nose area. Both of these conditions are acceptable for reuse.

The following three illustrations show wear patterns that are not acceptable for reuse.



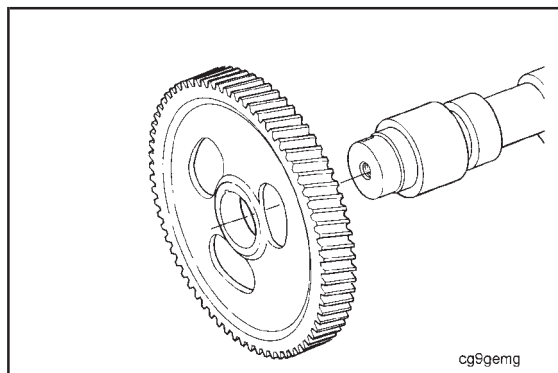

### Camshaft Gear - Replacement (1-18)



#### Camshaft Gear - Removal (1-19)

Remove the gear.

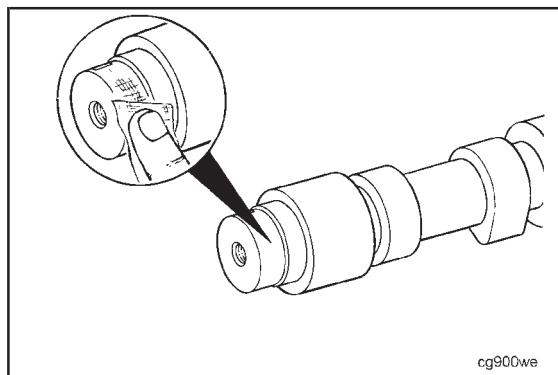

Remove all burrs and smooth any rough surfaces caused by removing the gear.

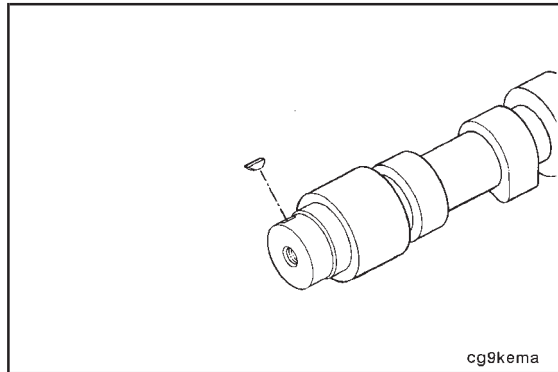

#### Camshaft Gear - Installation (Heated Gear Method) (1-20)

Install the key.

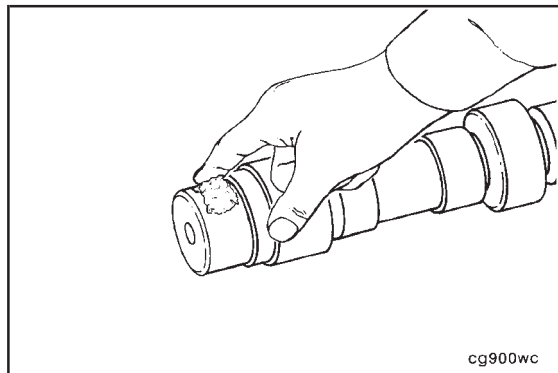

Lubricate the camshaft surface with Lubriplate 105.

**Caution:** The gear will be permanently distorted if overheated. The oven temperature should never exceed 177°C [350°F].

Heat the camshaft gear in a preheated oven at 149°C [300°F] for 45 minutes.

Heat the gear for bolted camshafts (steel gear) to 177°C [350°F].

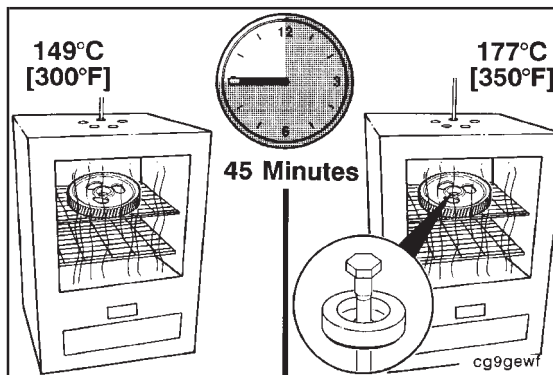

**Wear protective gloves to prevent personal injury.**

Install the gear with the timing marks away from the camshaft.

**Be sure the gear is seated against the camshaft shoulder.**

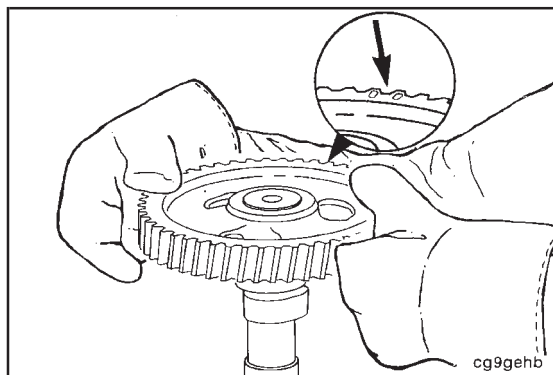

Automotive engines, manufactured before 1994, that use Bosch P7100 fuel pumps require a camshaft capscrew be installed. Refer to procedure (1-21)

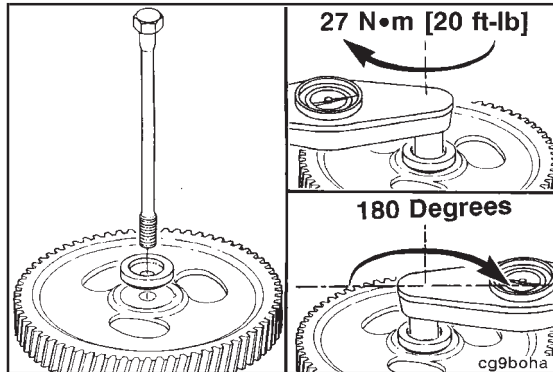

If the camshaft is not to be used immediately, lubricate the lobes and journals to prevent rusting.

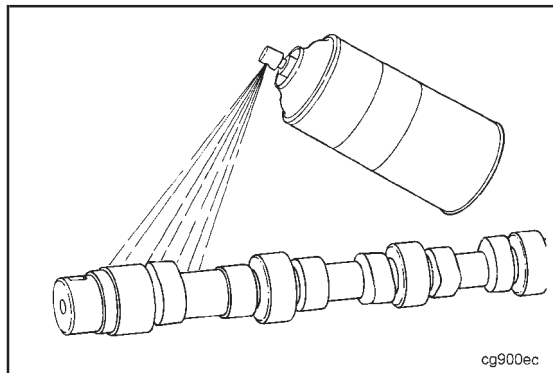



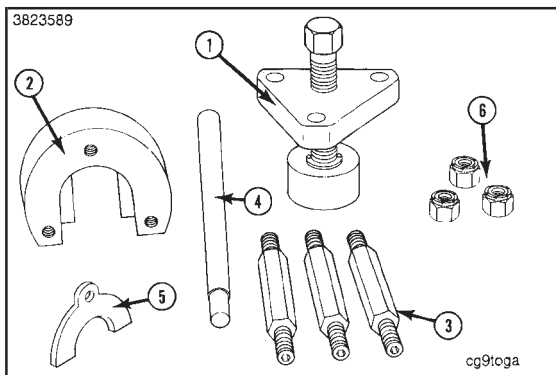

**Camshaft Gear - Installation (With Special Tool 3823589) (1-21)**

No.	Description	Qty.
1	Screw Press	1
2	Yoke	1
3	Rods	3
4	Torque Arm	1
5	Retainer	1
6	Nuts	3

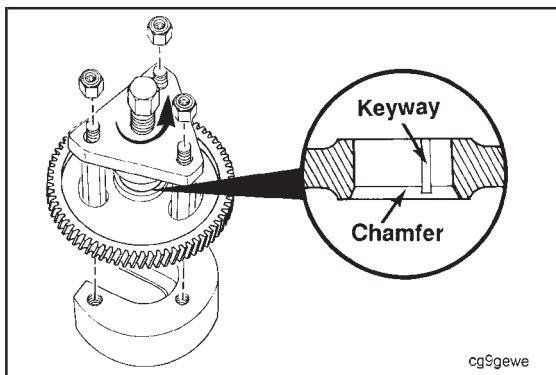

Assemble the screw press, yoke, rods, nuts, and camshaft gear with the chamfered side of the gear facing the camshaft.

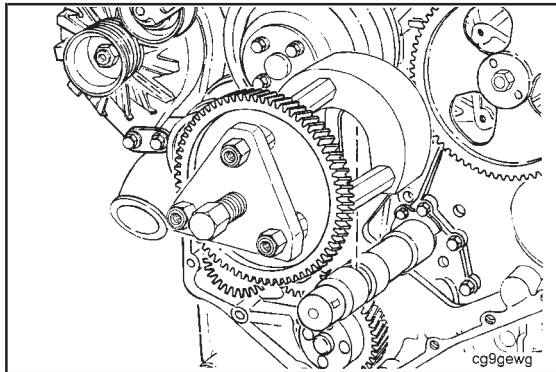

Clean all oil and lubricant from the camshaft and camshaft gear. Position the gear and tool assembly on the camshaft with the yoke placed over the end camshaft bearing journal.

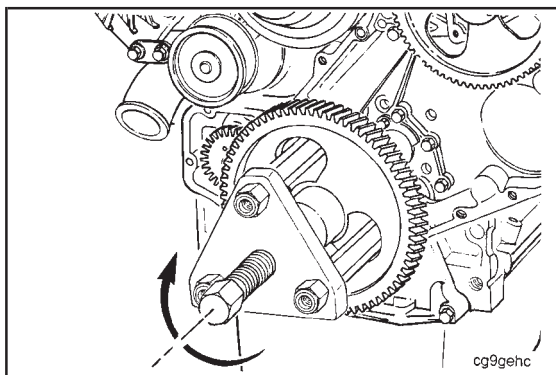

Hand-tighten the screw press and engage the gear to the camshaft and keyway.

Once the gear is properly started on the camshaft, insert the torque arm into the screw press and, using a wrench with the screw press, install the camshaft gear.

**NOTE:** Do not exceed 100 ft-lb of torque while installing the gear. Do not use an impact wrench with this or any other Cummins special tool. It can damage the engine parts or the tool.

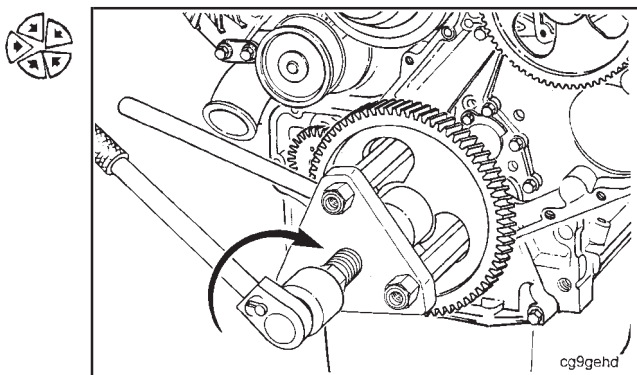

While turning the screw, the effort required should increase steadily until the gear seats against the camshaft shoulder.

When the gear is properly installed, the gear is in contact with the shoulder on the camshaft.

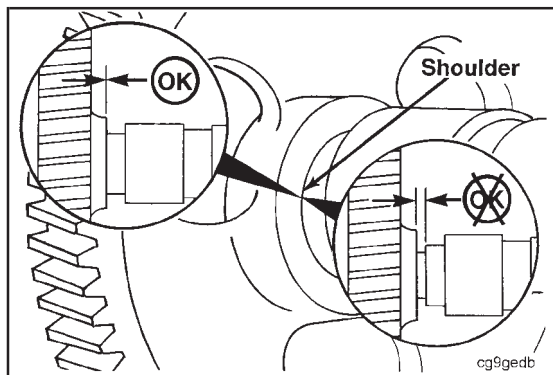

Disassemble the camshaft gear installation tool and remove the camshaft retainer.

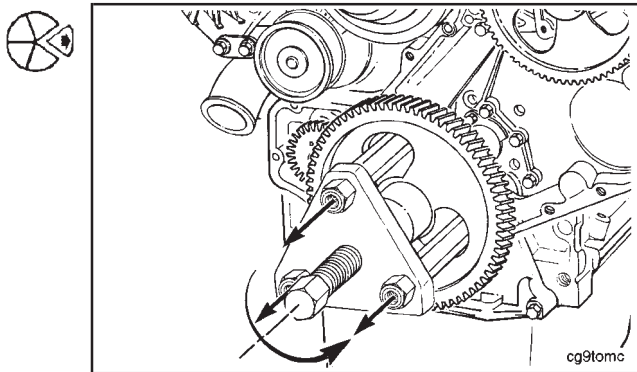

Automotive 1991 engines with Bosch P7100 inline injection require a camshaft capscrew be installed. Refer to procedure (1-22).

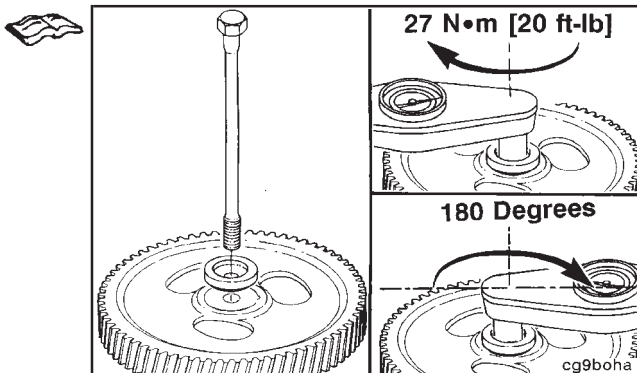

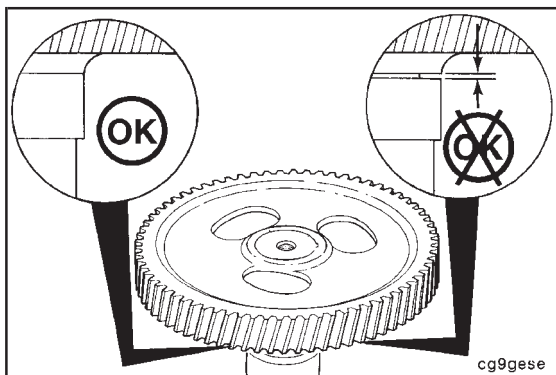

### Camshaft Capscrew - Installation (1-22)



**Be sure the gear is seated against camshaft shoulder.**

Using a .001 inch feeler gauge, check to see if the feeler gauge can be inserted between the gear and the shoulder on the camshaft. If the feeler gauge can be inserted, the gear is not properly seated.

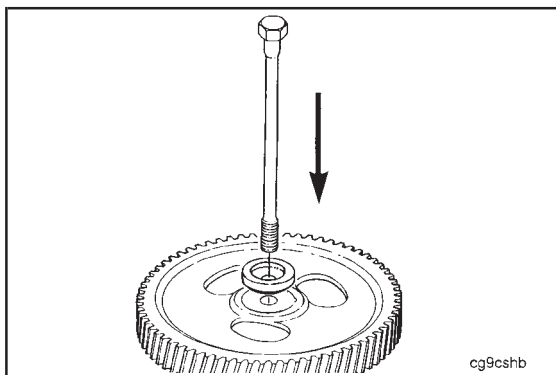

Insert the camshaft capscrew into the gear retainer and install the capscrew/retainer assembly into the camshaft.

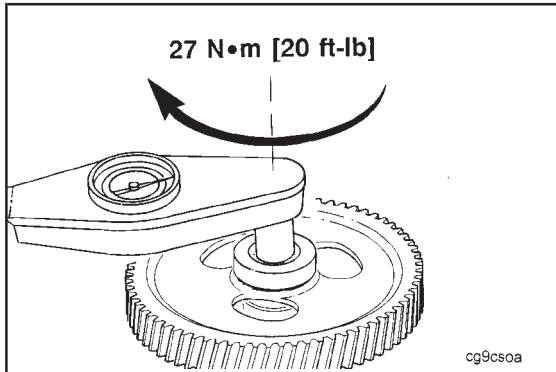

Torque the camshaft capscrew to 27 N•m [20 ft-lb].

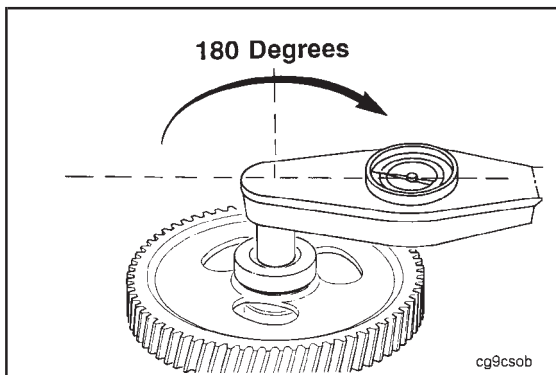

After torquing the camshaft capscrew to 27 N•m [20 ft-lb], then rotate the capscrew an additional 180° of rotation.

### Rubber Element Vibration Damper - Cleaning and Inspection (1-23)

Clean the damper with hot soapy water and a brush. After rinsing with clean water, use compressed air to dry.

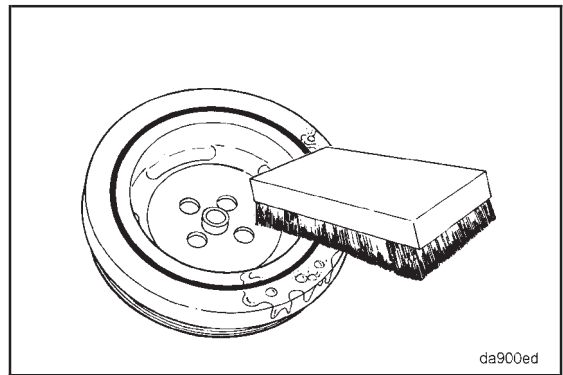

Check the index lines (A) on the damper hub (B) and inertia member (C). If the lines are more than 1.59 mm [1/16 in] out of alignment, replace the damper.

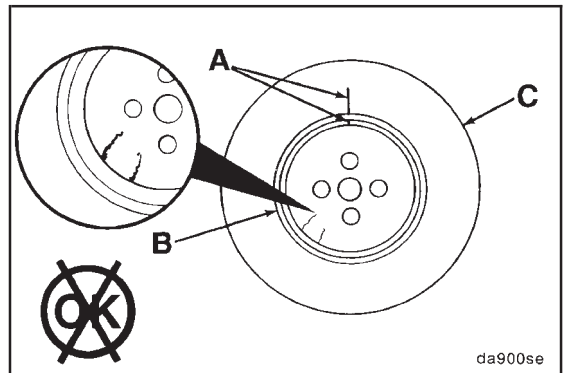

Inspect the rubber member for deterioration and missing pieces. If pieces of rubber are missing or the member is more than 3.18 mm [1/8 in] below the metal surface, replace the damper.

**NOTE:** Also look for forward movement of the damper ring on the hub. Replace the damper if any movement has occurred.

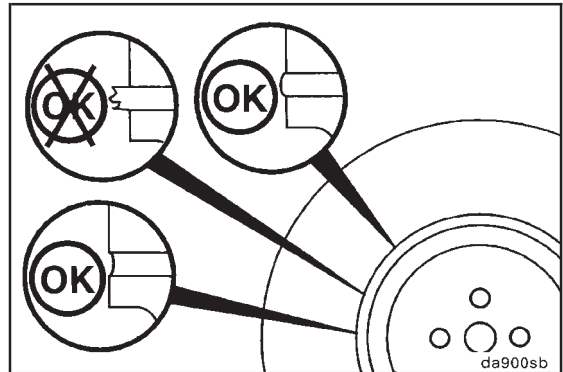

### Viscous Vibration Damper - Cleaning and Inspection

Check the mounting web for cracks. Check the housing for dents or raised surfaces. Replace the damper if any of these defects are identified. Refer to replacement procedure in this section.

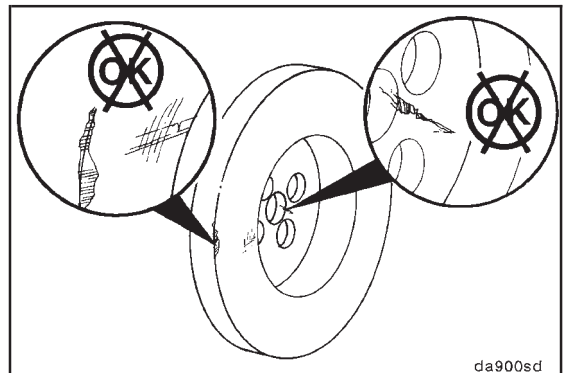

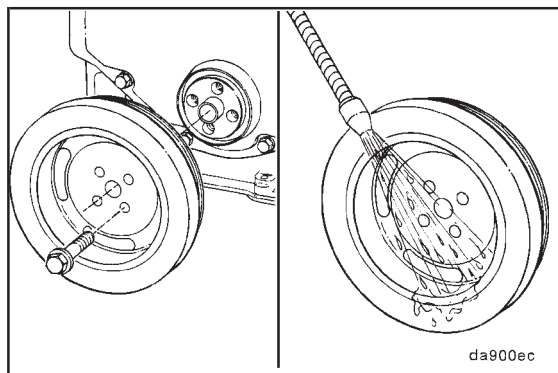

Clean the damper with a solvent cleaner.

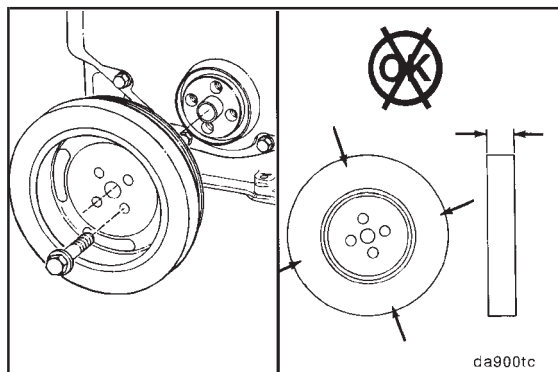

The viscous damper is filled with a silicone fluid. After many hours or use, the silicone fluid may become thicker and expand. To determine if the damper thickness is correct, remove the paint from the damper in four locations on either side of the damper. Measure and record the thickness of the damper in four places. Measure the thickness 3.175 mm [0.125 inch] from the out side of the damper. Replace the damper if its thickness varies by more than 0.25 mm [0.010 inch].

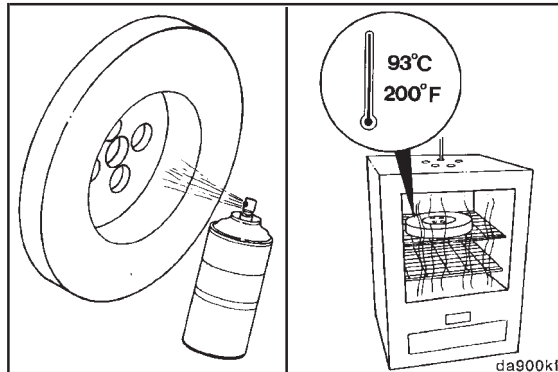

Spray the damper with spot check developer, Type SKD-NF or its equivalent. Heat the damper in an oven (rolled lip side down) at 93°C [200°F] for 2 hours.

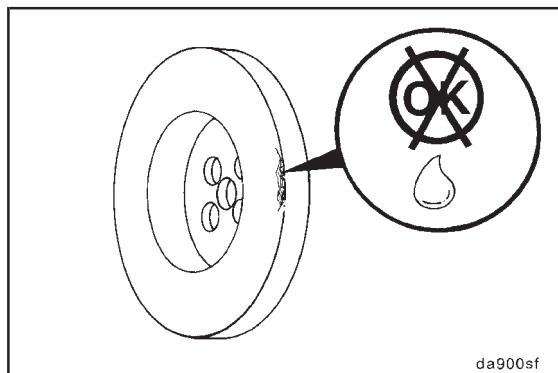

**Caution:** Wear protective gloves to prevent personal injury when handling parts that have been heated.

Remove the damper from the oven and check for fluid leakage. If there is leakage, replace the damper.

### Piston and Connecting Rod - Disassembly (1-24)

Remove the retaining rings.

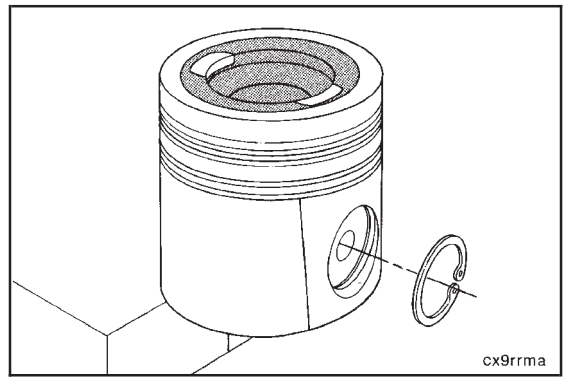

Remove the piston pin.

Heating the piston is not required.

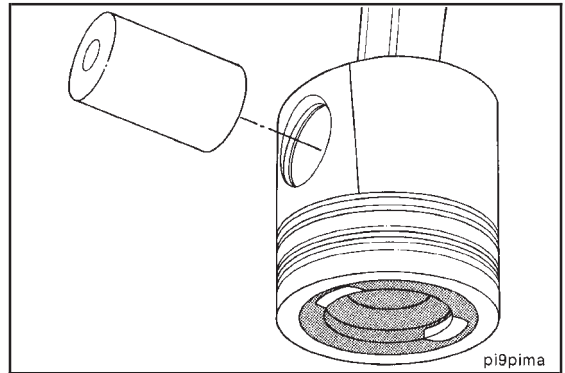

### Piston Ring Expander Part No. 3823137

Remove the piston rings.

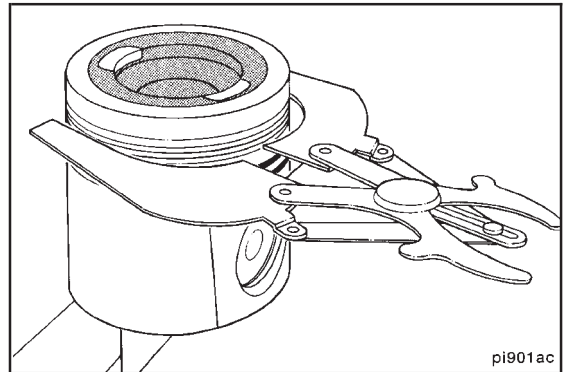

### Piston, Pin and Connecting Rod - Cleaning (1-25)

**Caution:** Do not use the bead blast method to clean the piston. The piston will be damaged by blast material embedded in the aluminum.

Soak the pistons in cold parts cleaner.

Soaking the pistons overnight will usually loosen the carbon deposits.

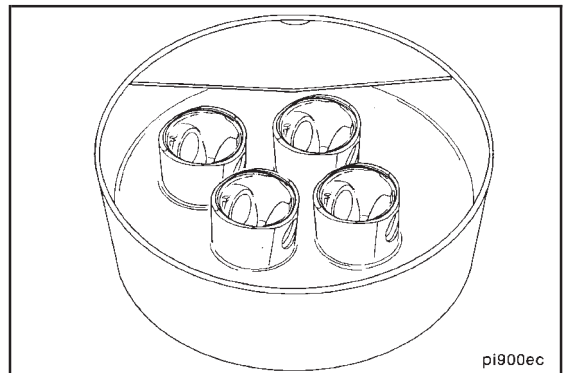

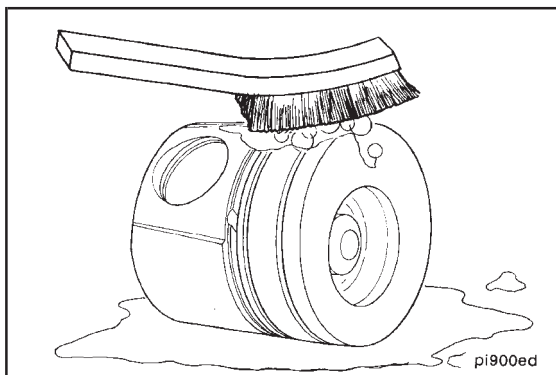

**Caution:** Do not clean the pistons and rods in an acid tank.



Wash the pistons and rods in a strong solution of laundry detergent in hot water.

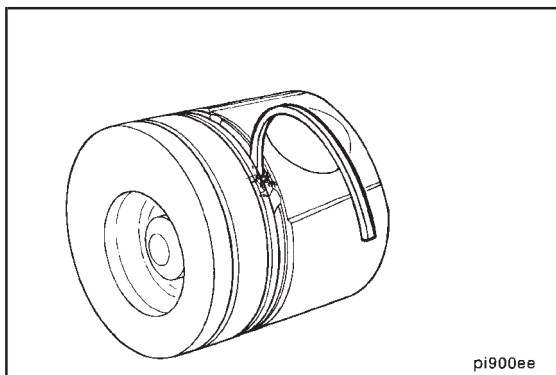

**Caution:** Do not use a ring groove cleaner and be sure not to scratch the ring sealing surface in the piston groove.



Clean the remaining deposits from the ring grooves with the square end of a broken ring.

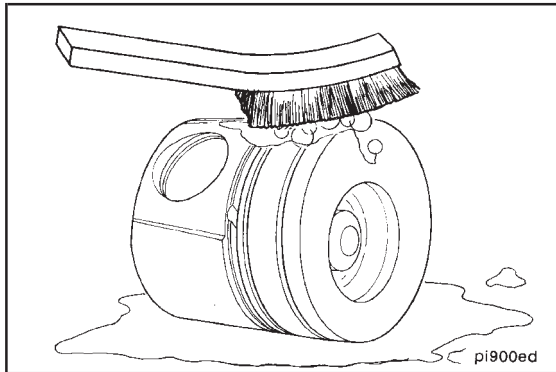

Wash the pistons again in a detergent solution or solvent. After rinsing, use compressed air to dry.

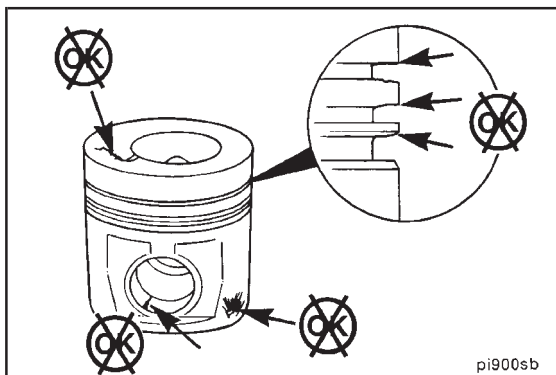

### Piston Inspection (1-26)

Inspect the piston for damage and excessive wear. Check the top, ring grooves, skirt and pin bore.

Measure the piston skirt diameter as illustrated.

Diameter		
mm		in
101.823	MIN	[4.0088]
101.887	MAX	[4.0113]

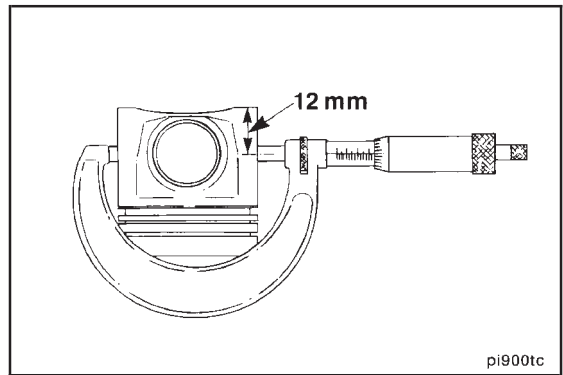

Use a new piston ring to measure the clearance in the ring groove.

Ring Clearance			
	mm		in
<b>Top</b> (Turbocharged)	No Check Needed		
(Naturally Aspirated)	0.075	MIN	[0.003]
	0.150	MAX	[0.006]
<b>Intermediate</b>	0.075	MIN	[0.003]
	0.150	MAX	[0.006]
<b>Oil Control</b>	0.040	MIN	[0.002]
	0.130	MAX	[0.005]

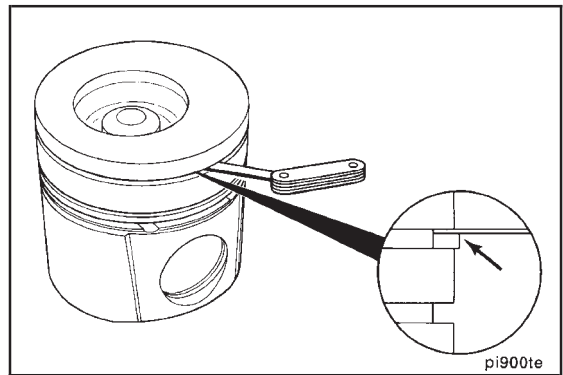

Measure the pin bore.

Diameter		
mm		in
40.006	MIN	[1.5750]
40.025	MAX	[1.5758]

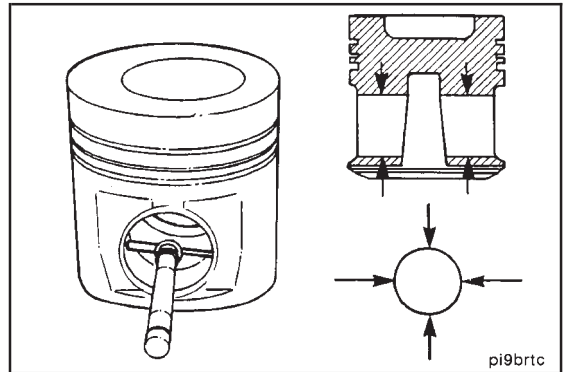

### Piston Pin - Inspection (1-27)

Inspect the piston pin for nicks, gouges and excessive wear.

Measure the pin diameter.

Diameter		
mm		in
39.990	MIN	[1.5744]
40.003	MAX	[1.5749]

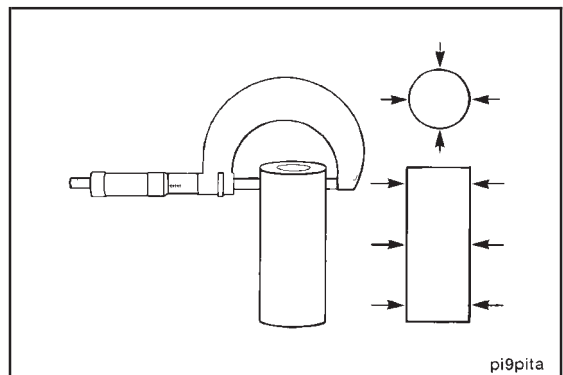



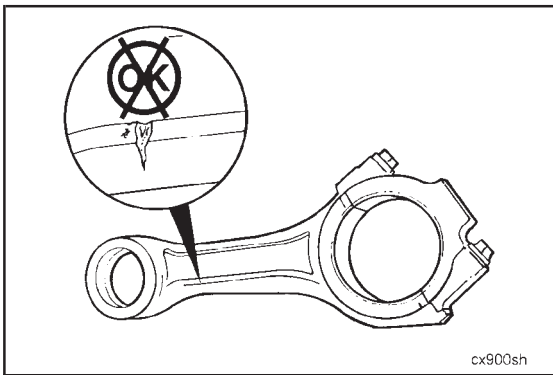

### Connecting Rod - Inspection (1-28)

**Caution:** The I-Beam section cannot have dents or other damage. Damage to this part can cause stress risers which will progress to breakage.

Inspect the rod for damage and wear.

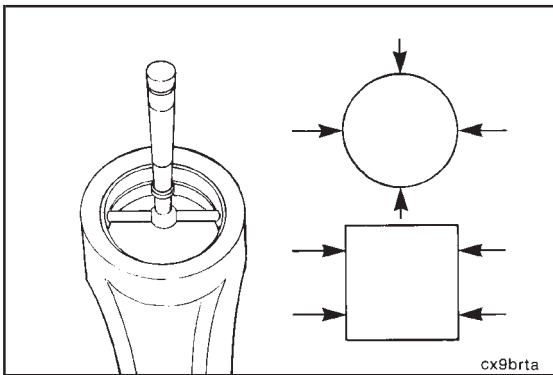

Measure the pin bore (with bushing installed).

#### 1991 Specifications

Diameter		
mm		in
40.053	MIN	[1.5769]
40.076	MAX	[1.5778]

#### 1994 Specifications

Diameter		
mm		in
40.019	MIN	1.5756
40.042	MAX	1.5765

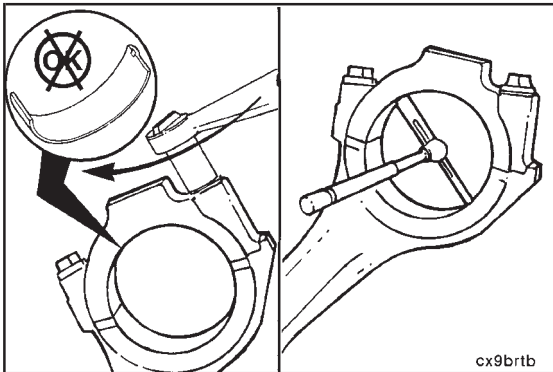

### Rod Bearing Clearance - Checking (1-29)

Measure the crankshaft bore with the bearings installed and the capscrews tightened to 99 N•m [73 ft-lb].

Record the smallest diameter.

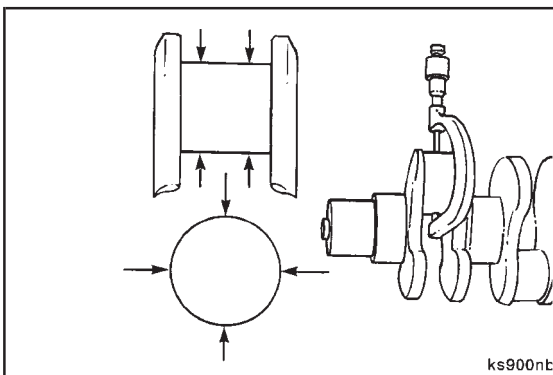

Measure and record the mean diameter of rod journal on the crankshaft.

Diameter		
mm		in
68.962	MIN	[2.7150]
69.013	MAX	[2.7170]

**Out-of-Roundness:** 0.050mm [0.002 in]

**Taper:** 0.013mm [0.0005 in]

Bearing clearance = Rod Inside Diameter Minus Crankshaft Journal Diameter.

**Clearance:** 0.114mm [0.0045 in] maximum

Bearing clearance can also be determined with plastigage during engine assembly.

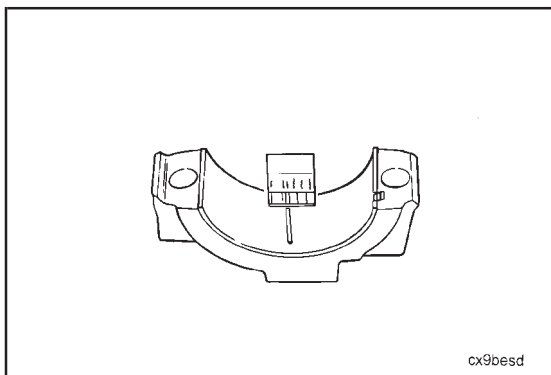

cx9besd

### Piston and Connecting Rod - Assembly (1-30)

Be sure "front" marking on piston and the numbers on the rod and cap are oriented as illustrated.

**NOTE:** The numbers shown in the illustration are for example purposes only.

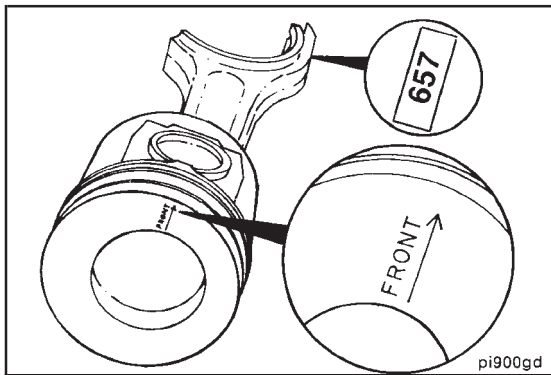

pi900gd

Install the retaining ring in the pin groove on the "front" side of the piston.

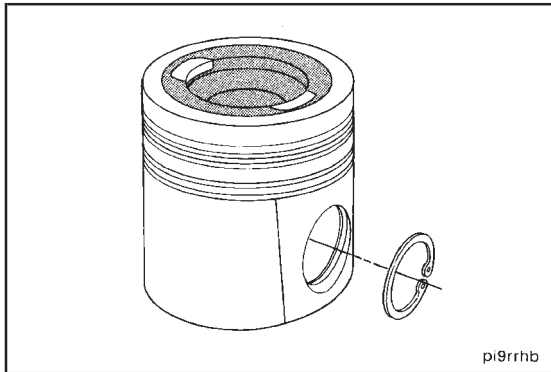

pi9rrhb

Lubricate the pin and pin bores with engine oil.

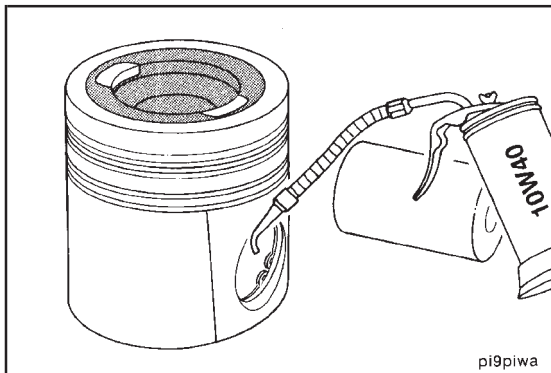

pi9piwa

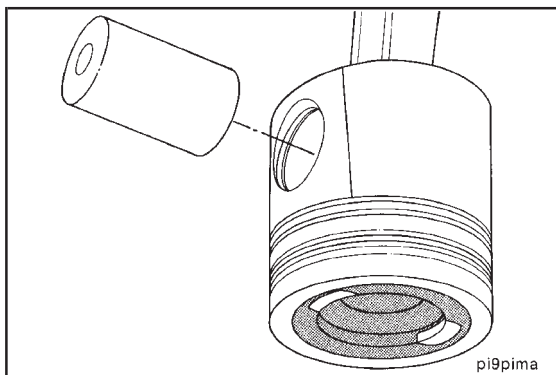

Install the pin.

Pistons do not require heating to install the pin, however, the pistons do need to be at room temperature or above.

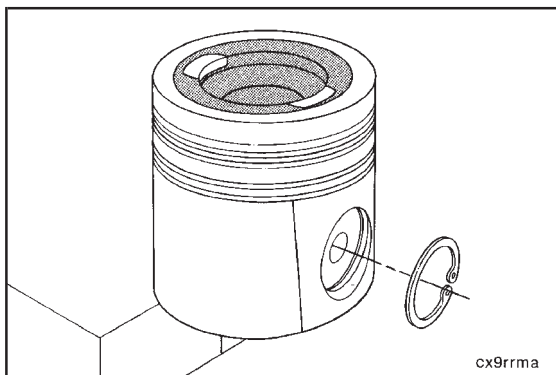

Install the second retaining ring.

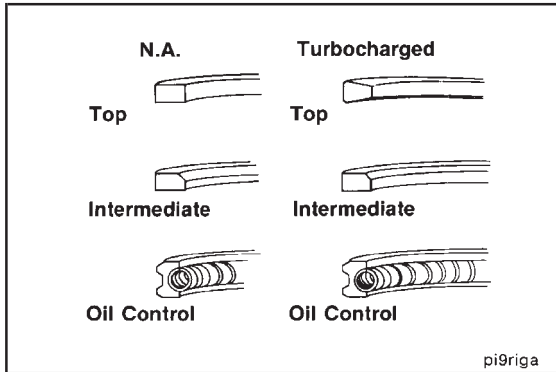

### Piston Ring Gap - Checking (1-31)

The top ring for a turbocharged engine is not the same as the top ring for a naturally aspirated engine.

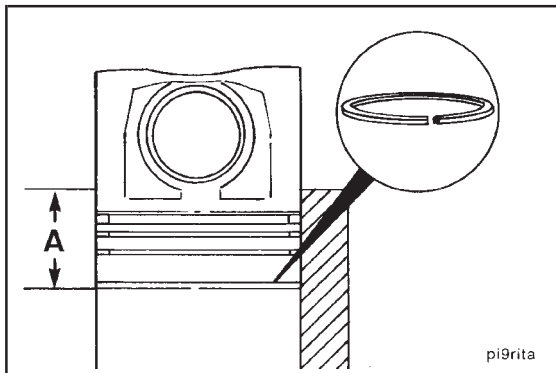

Position each ring in the cylinder and use a piston to square it with the bore.

A = 89mm [3.5 in]

Use a feeler gauge to measure the gap.

	Ring Gap		in
	mm		
<b>Top</b> (Turbocharged)	0.40	MIN	[0.016]
	0.70	MAX	[0.028]
<b>Top</b> (N. Aspirated)	0.25	MIN	[0.010]
	0.55	MAX	[0.022]
<b>Intermediate</b>	0.25	MIN	[0.010]
	0.55	MAX	[0.022]
<b>Oil Control</b>	0.25	MIN	[0.010]
	0.55	MAX	[0.022]

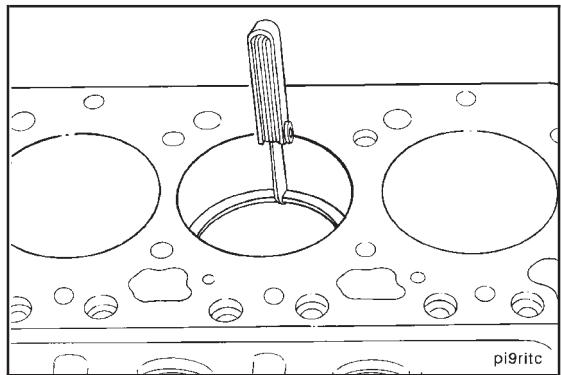

### Piston Rings - Installation (1-32)

**Caution:** If a ring expander tool is being used, be careful not to over expand the ring.

The top surface of all of the rings are identified: Assemble the word "top" up.

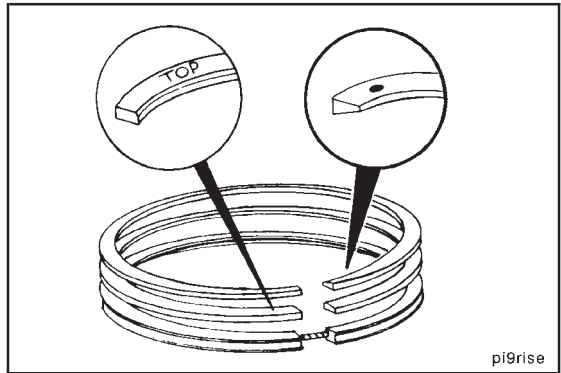

Position the oil ring expander in the control ring groove.

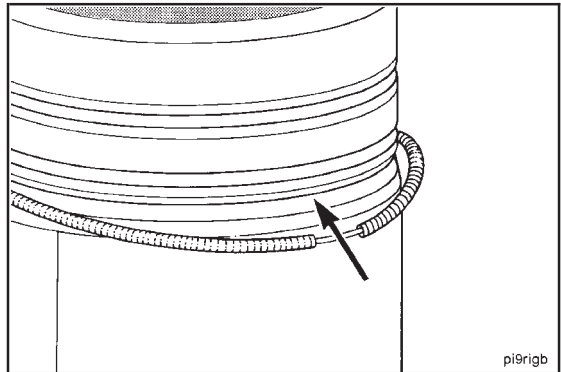

Install the oil control ring with the end gap 180° from the ends of the expander.

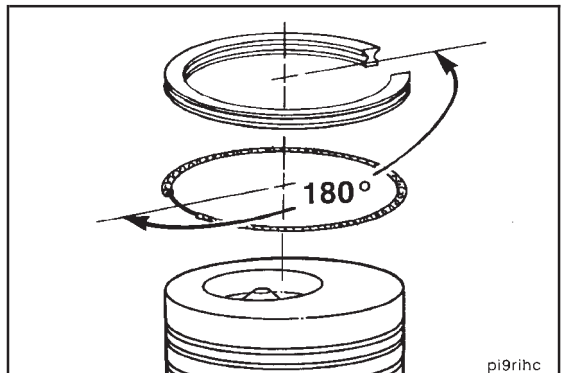

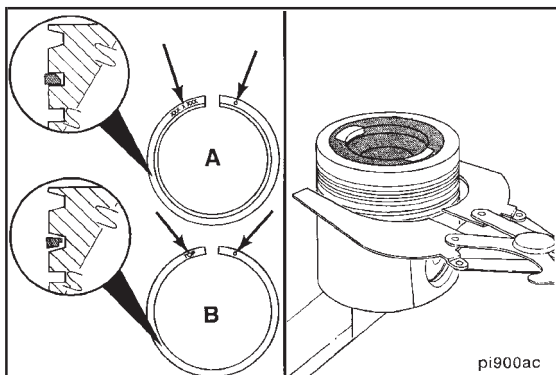

**Piston Ring Expander, Part No. 3823137**

Install the intermediate ring.

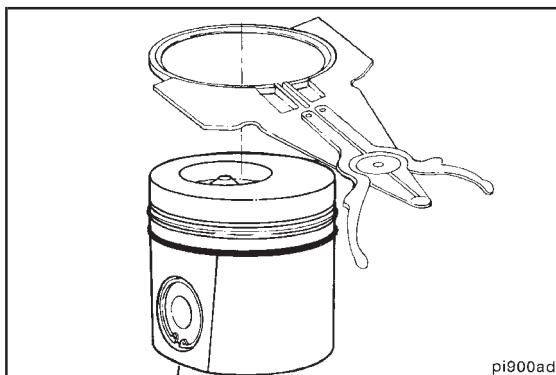

**Piston Ring Expander, Part No. 3823137**

The top ring for a turbocharged engine is not the same as the top ring for a naturally aspirated engine.

Install the top ring.



**Balancer - Disassembly (1-33)**



Refer to the procedures and specifications given in the engine disassembly section, procedure (0-59), (0-60) and (0-61).

- The idler gear must be replaced if the backlash end play exceed the specifications.
- The shaft gears must be replaced if the backlash exceeds the specifications.
- The thrust bearing must be replaced if the shaft end play exceeds the specifications.

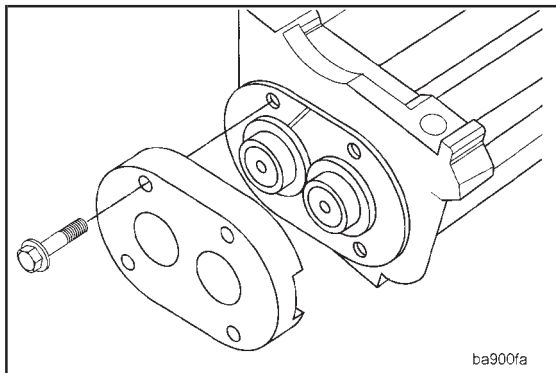

**13 mm**

Remove the thrust housing.



**8 mm Allen**

Remove the idler gear assembly.

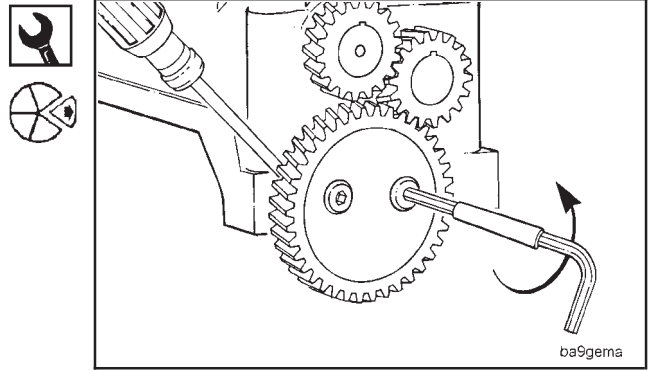

**13 mm**

Remove the balancer weights.

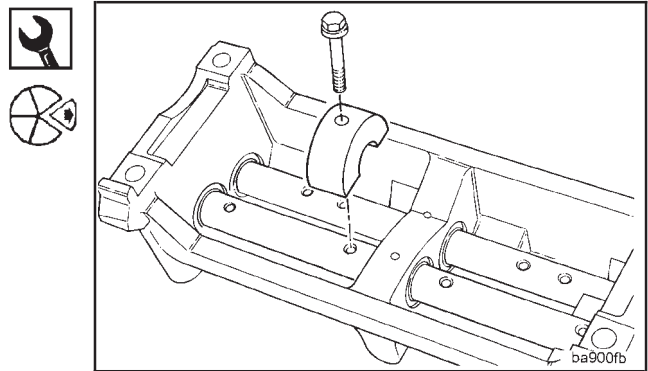

Press the shafts from the gears.

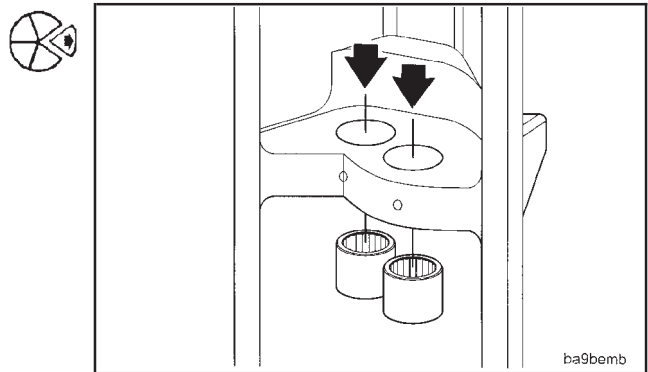

Remove the shafts from the balancer housing.

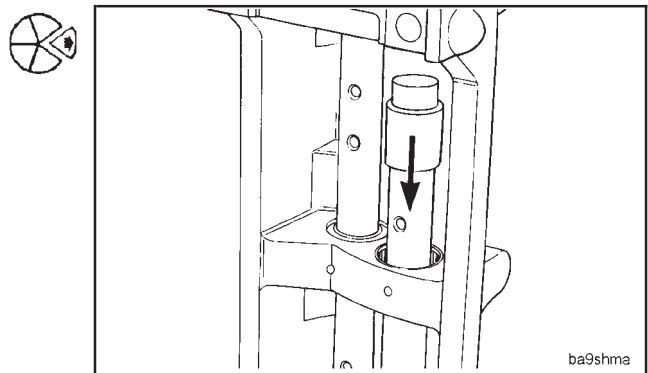

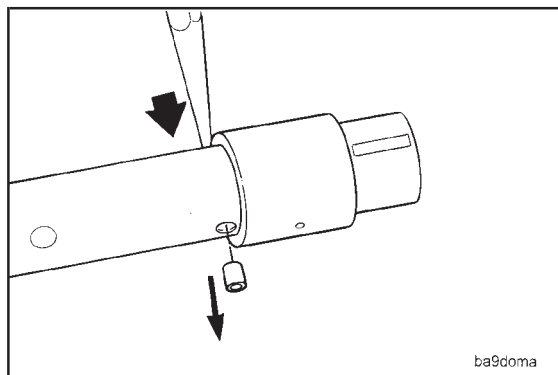

**3/16 Inch Punch, Hammer**

Use the punch to drive the roll pins from the shafts.

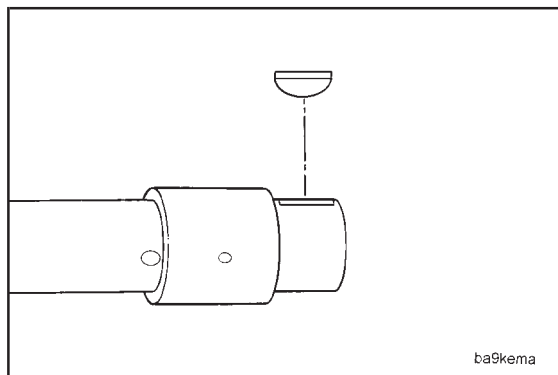

Remove the Woodruff keys from the shafts.

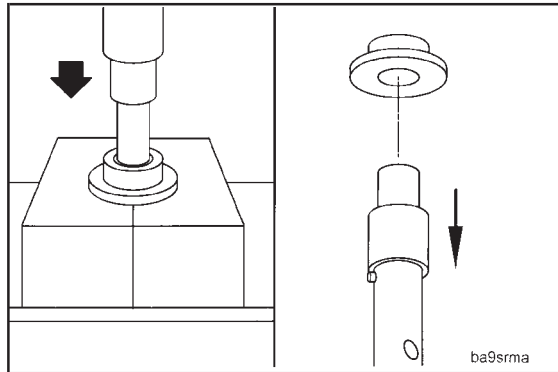

Press the shafts out of the thrust collars.

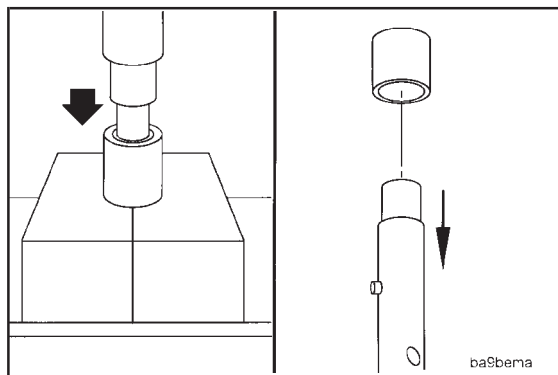

Press the shafts out of the bearing inner races.

Press the bearings out of the balancer housing.

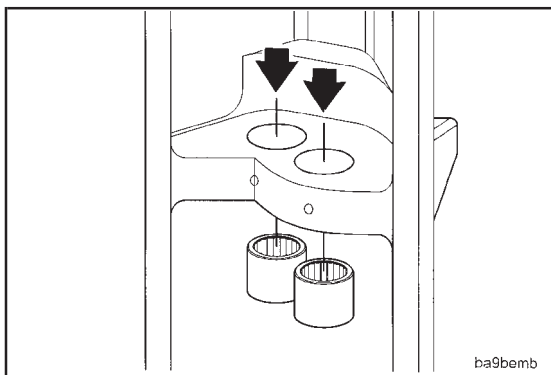

### Balancer - Assembly (1-34)

The oil hole in the center bearings **must** align with the oil hole in the housing. Mark the housing and bearings so you can align the holes.

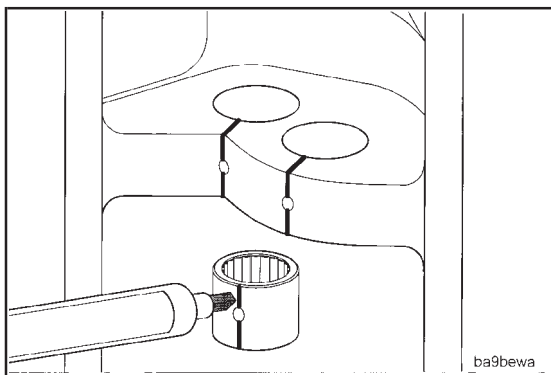

**Caution:** Press against the end of the bearing that has the identification mark. Failure to do so will result in damage to the bearing.



Press in the new center bearings until flush with the housing.

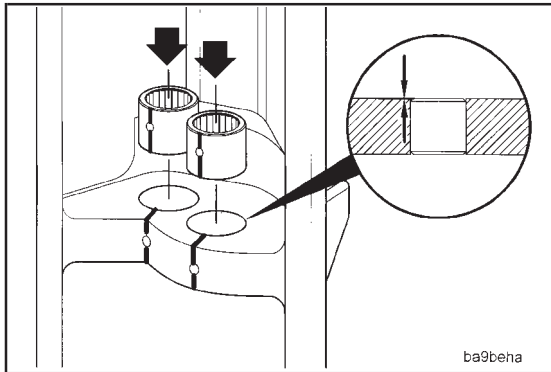

Install the bearings in the housing so the identification marks are toward the outside of the housing.

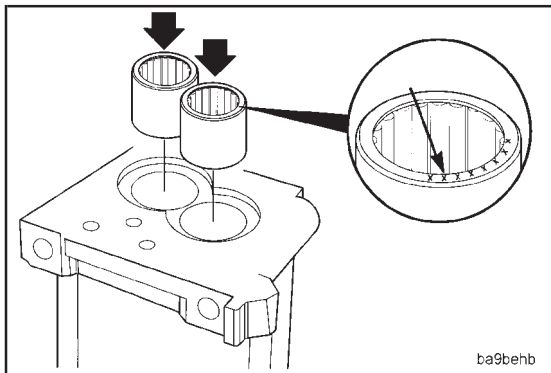



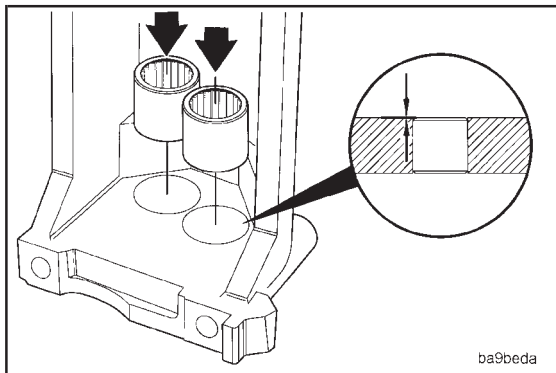

**Caution:** Press against the end of the bearing that has the identification mark. Failure to do so will result in damage to the bearing.



Press in the new bearings until flush with the inside of the housing.

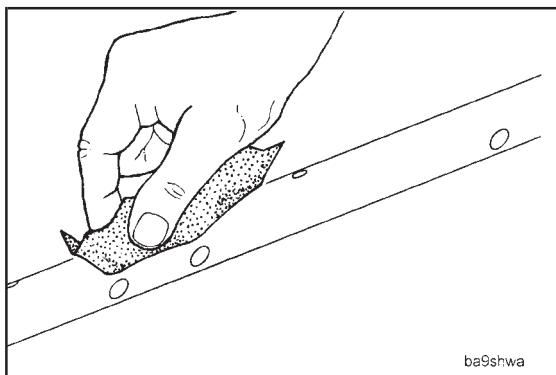

The balancer shafts must be sub-assembled before being installed into the housing. The assembly procedure is the same for both shafts.

Use 500 grit sandpaper to polish the bearing surfaces and to remove burrs and Loctite material.



Use cleaning solvent to clean the shafts and bearing surfaces.

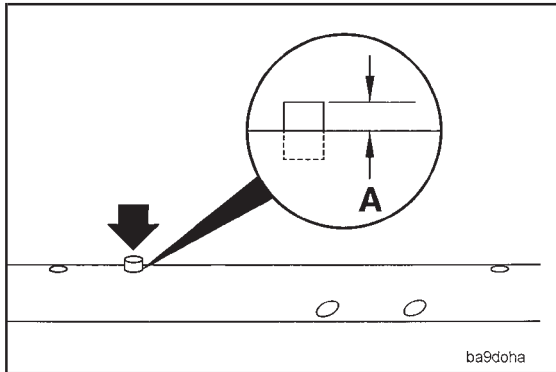

**Hammer or Mallet**

Install a new roll pin into one of the center holes in the shafts.



A = 2.5 mm [0.09 (3/32) in]

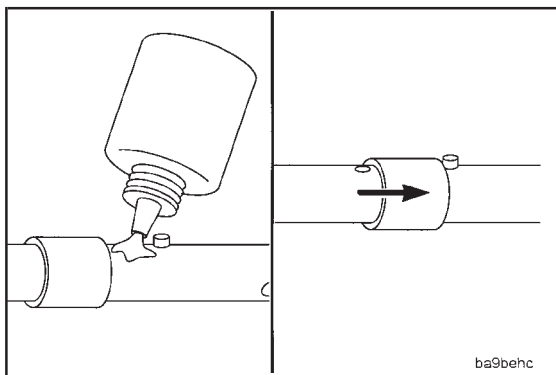

Apply a coat of Loctite 609 to the bearing surface of the shaft. Slide a new inner race into position on the shaft.

Remove the excessive Loctite from the shaft.

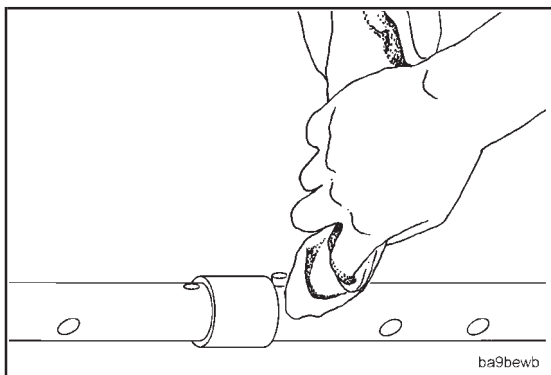

Install the three remaining roll pins.

A = 2.5 mm [0.09 (3/32) in]

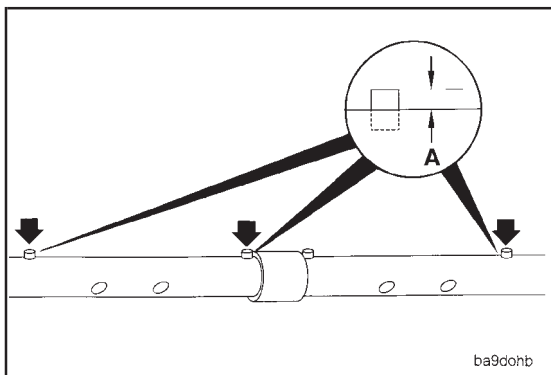

Apply a coat of Loctite 609 to the bearing surfaces.

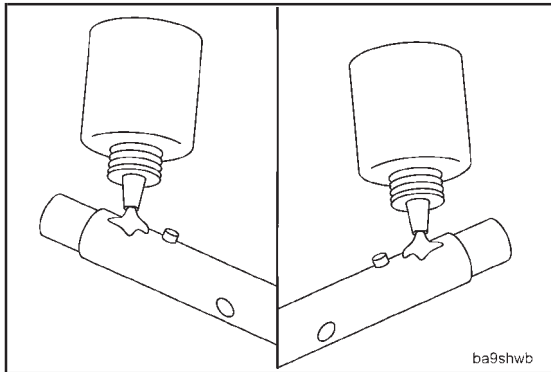

Slide two new inner races onto the ends of the shafts. The identification marks must be toward the end of the shaft.

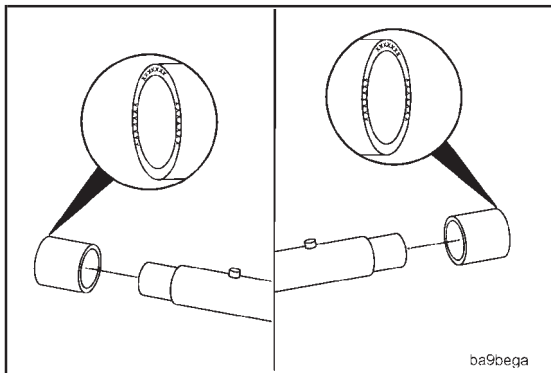

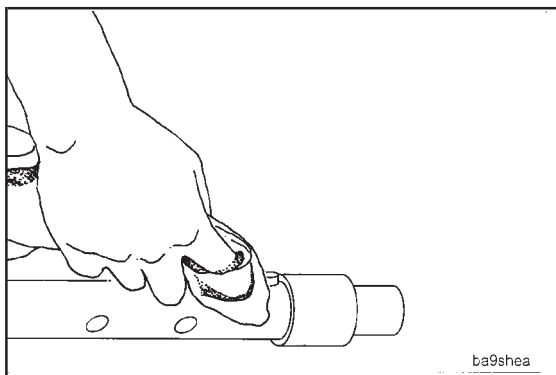

Remove the excessive Loctite.

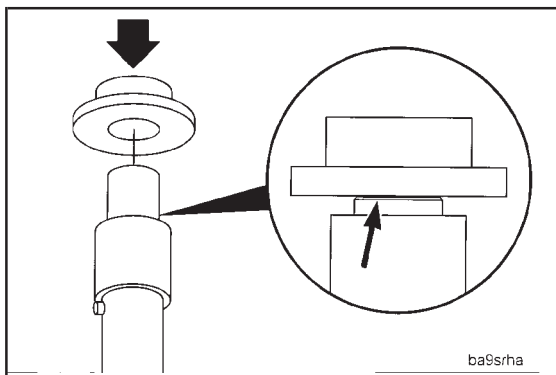

Press on the thrust collars to the step on the shafts.

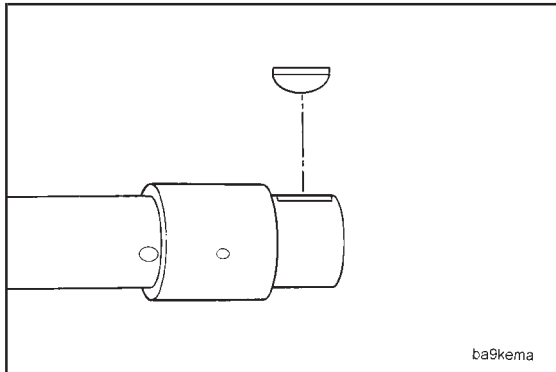

Install the Woodruff keys into the shafts.

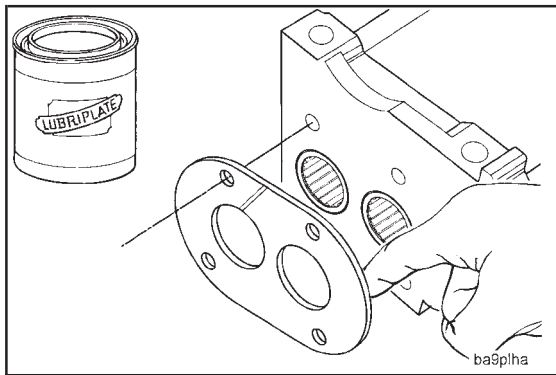

Apply a coat of lubriplate to the thrust plate. Position the thrust plate onto the housing.



Use clean engine oil to lubricate the bearings. Install the bottom shaft into the housing. The bottom shaft has the hole for the timing pin.



**NOTE:** Late model shafts have a tapped hole for the timing pin. Earlier shafts have the timing pin hole drilled completely through the shaft.

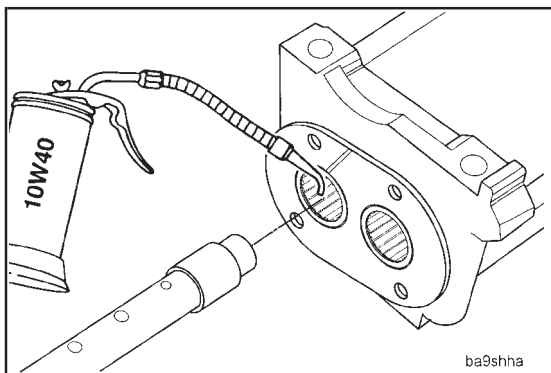

ba9shha

Press the gear that has one timing mark onto the bottom shaft until the gear is flush with the end of the shaft.

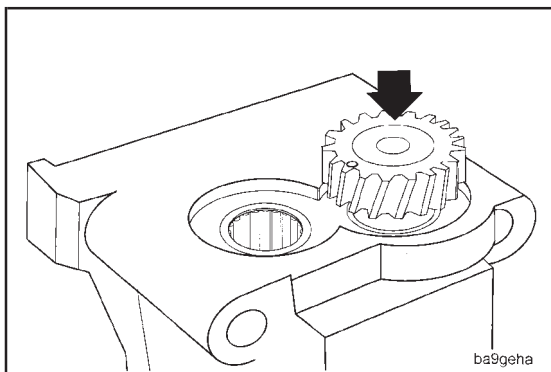

ba9geha

Use clean engine oil to lubricate the bearings and install the top shaft.

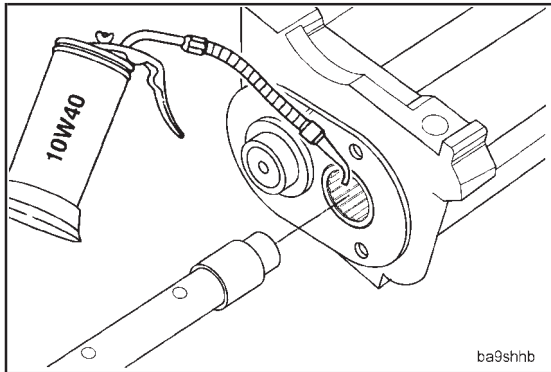

ba9shhb

**Caution:** The timing marks must be aligned when you press the gear onto the shaft.



Press on the gear that has two timing marks until the gear is flush with the end of the shaft.

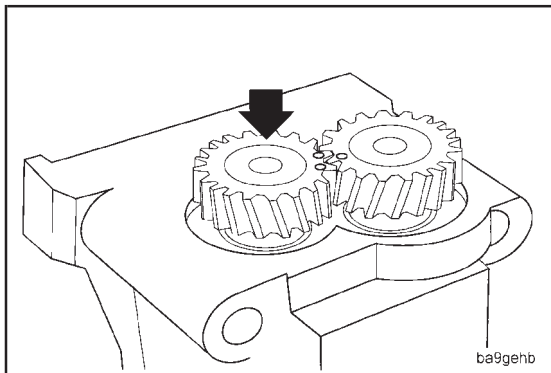

ba9gehb

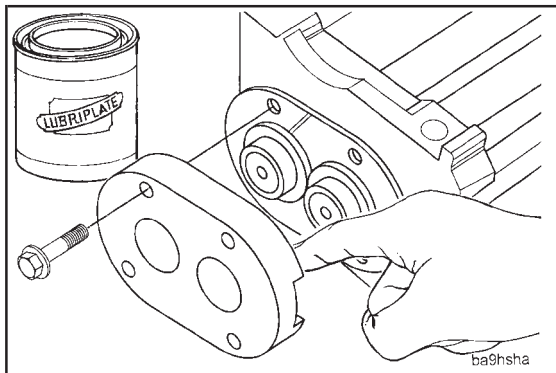

13 mm



Apply a coat of lubriplate to the thrust housing. Install the thrust housing. **The mounting holes align in only one position.**



**Torque Value:** 24 N•m [18 ft-lb]

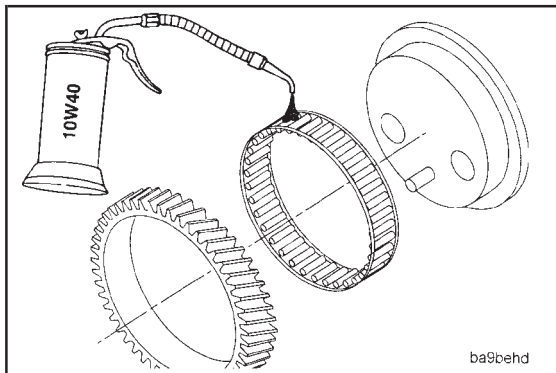

Use clean engine oil.



Lubricate and install a new bearing into the idler gear assembly.

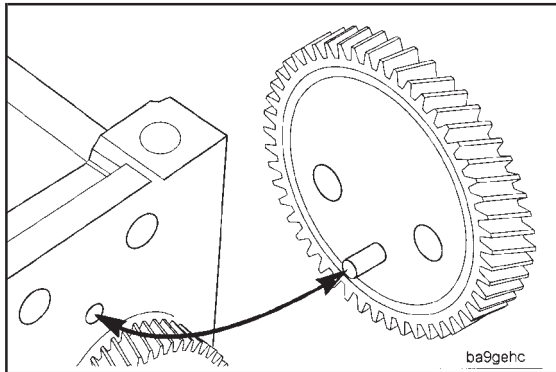

Align the idler gear assembly alignment pin with the hole in the housing.

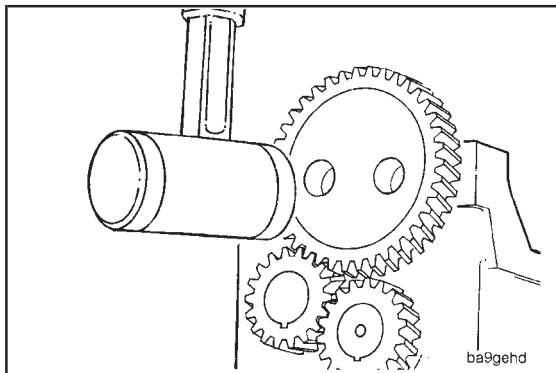

**Plastic Mallet**



Tap the idler assembly gently into position.

Install the two Allen head capscrews into the idler assembly. Use your fingers to tighten the capscrews.

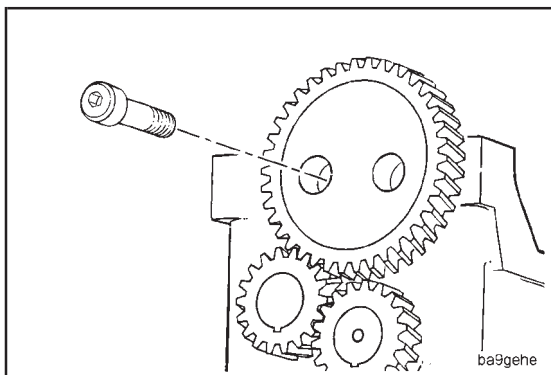

**8 mm Allen**

Install the balancer weights onto the shafts. The weights must be installed on the counterbore side of the holes.

**Torque Value:** 24 N•m [18 ft-lb]

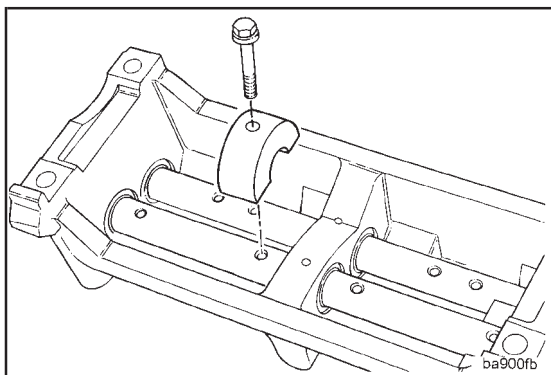

Check the balancer assembly for free rotation. If it does not rotate freely, check the thrust housing and bearings for correct installation.

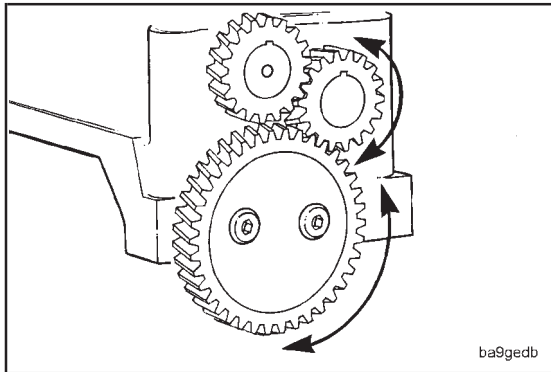

**Gear Housing and Timing Pin Assembly - Inspection (1-35)**

Visually inspect the gear housing for cracks or damaged sealing surfaces.

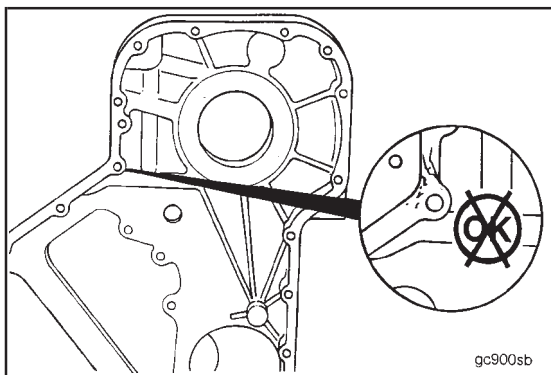

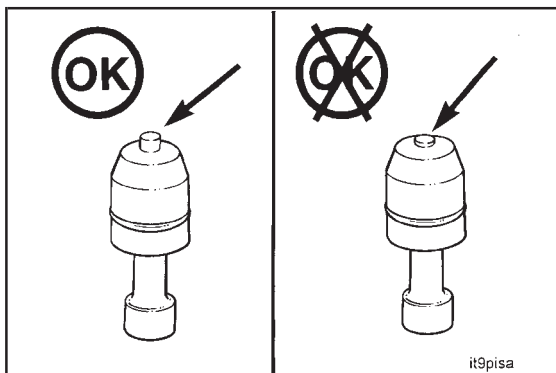

Inspect the timing pin housing and pin for damage.

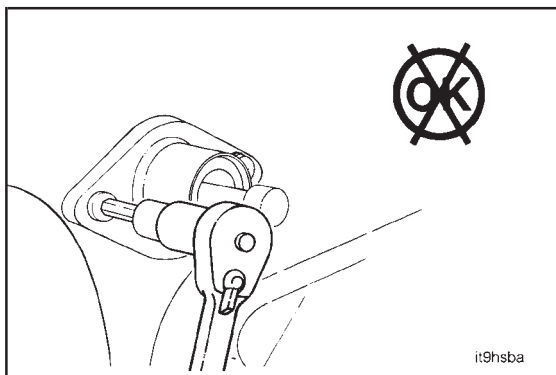

### Gear Housing - Disassembly (1-36)

Do not remove the timing pin housing unless it is damaged or leaking, or the gear housing is being replaced. Refer to Page 0-57 for replacement procedures.

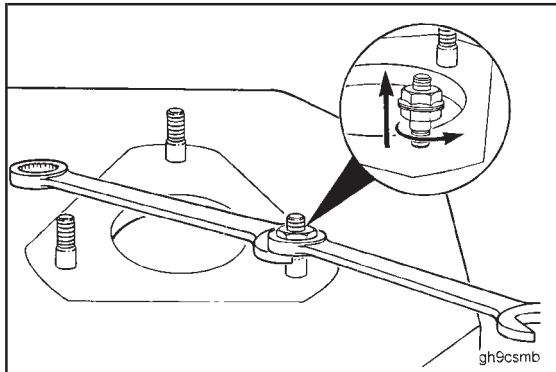

13 mm

To install or remove fuel pump studs, use two nuts jam locked onto the stud.

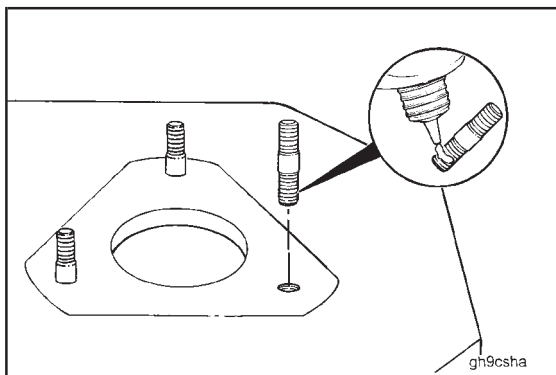

13 mm

Coat the threads with Loctite™ 601 prior to installation.



## Data Plate - Replacement (1-38)

### Small Chisel and Hammer

If the gear housing is being replaced, remove the engine data tags and install on the new housing.

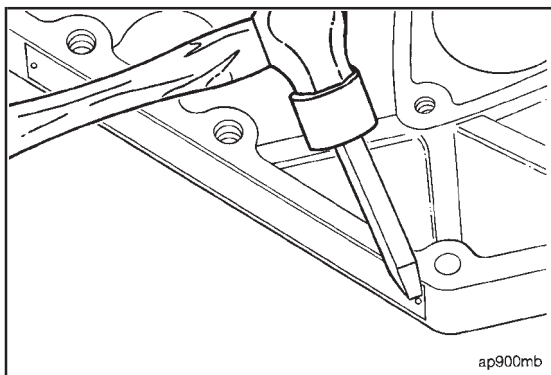

Drive the rivets in until they contact the data tag.

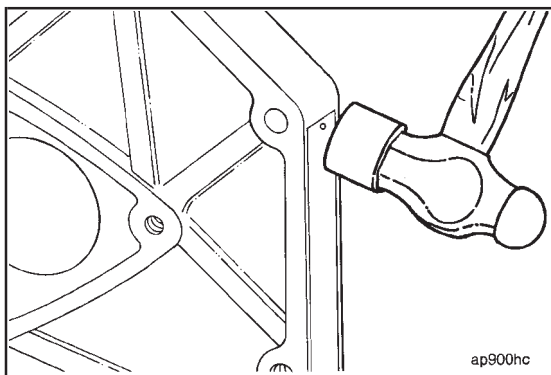

**Caution:** If the rivets are driven in too far, they will cut through the data tag.

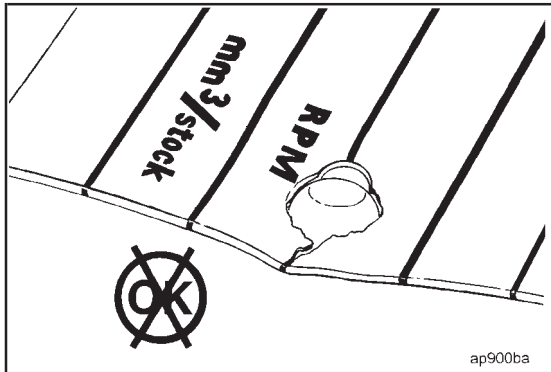

### 2.0 mm Drill Bit

If the data tag is loose or has been damaged, drill new holes and attach with new rivets. Mark the drill bit at 6.0 mm [0.236 in (15/64)] to avoid drilling too deep.

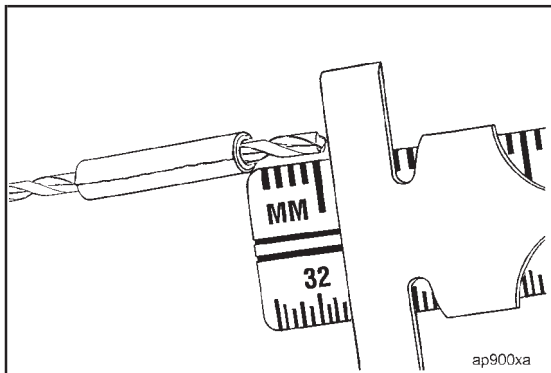



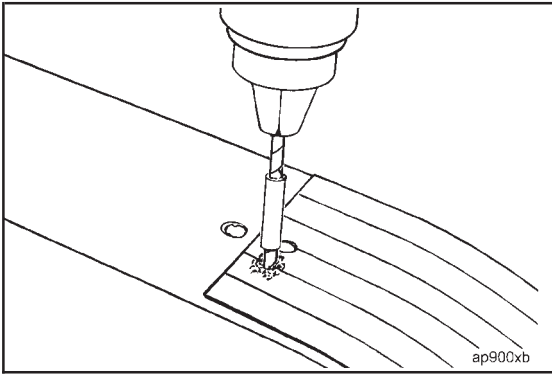

Drill the data tag taking care not to interfere with the printed data on the tag.

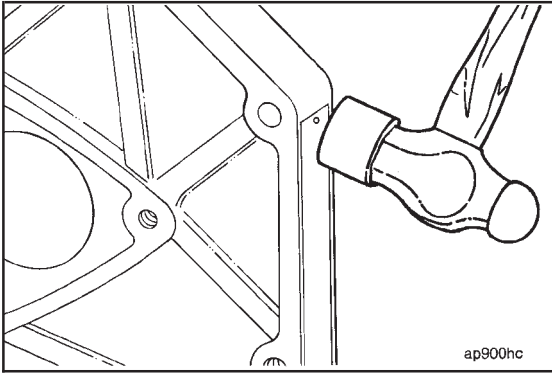

Drive the rivets in until they contact the data tag.

## Section 2 - Cylinder Head - Section 2

### Section Contents

	Page
Cup Plug Replacement .....	2-13
Cylinder Head - Assembly .....	2-21
Cylinder Head - Cleaning.....	2-7
Cylinder Head - Disassembly .....	2-6
Cylinder Head - Precheck Before Disassembly .....	2-6
Cylinder Head - Service Tools .....	2-2
Cylinder Head Combustion Face Inspection .....	2-11
Cylinder Head Cracks - Reuse Guidelines .....	2-12
Exploded View .....	2-3
General Information .....	2-5
Valve - Inspection .....	2-9
Valve Guide Inspection .....	2-11
Valve Seat Inspection.....	2-11
Valve Seats - Grinding .....	2-16
Calculating the Grinding Depth.....	2-16
Measuring the Valve Depth.....	2-16
Valve Spring Inspection .....	2-12
Valves - Grinding.....	2-15

### Cylinder Head - Service Tools

The following special tools are recommended to perform procedures in Group 02. The use of these tools is shown in the appropriate procedure. These tools can be purchased from your local Cummins Authorized Repair Location.

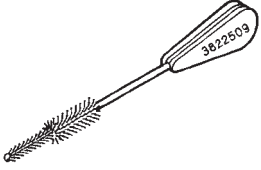
Tool No.	Tool Description	Tool Illustration
3822509	Injector Bore Brush	 <small>3822509</small>
3823495	Gauge Block	

# Cylinder Head - Group 2

## Exploded View

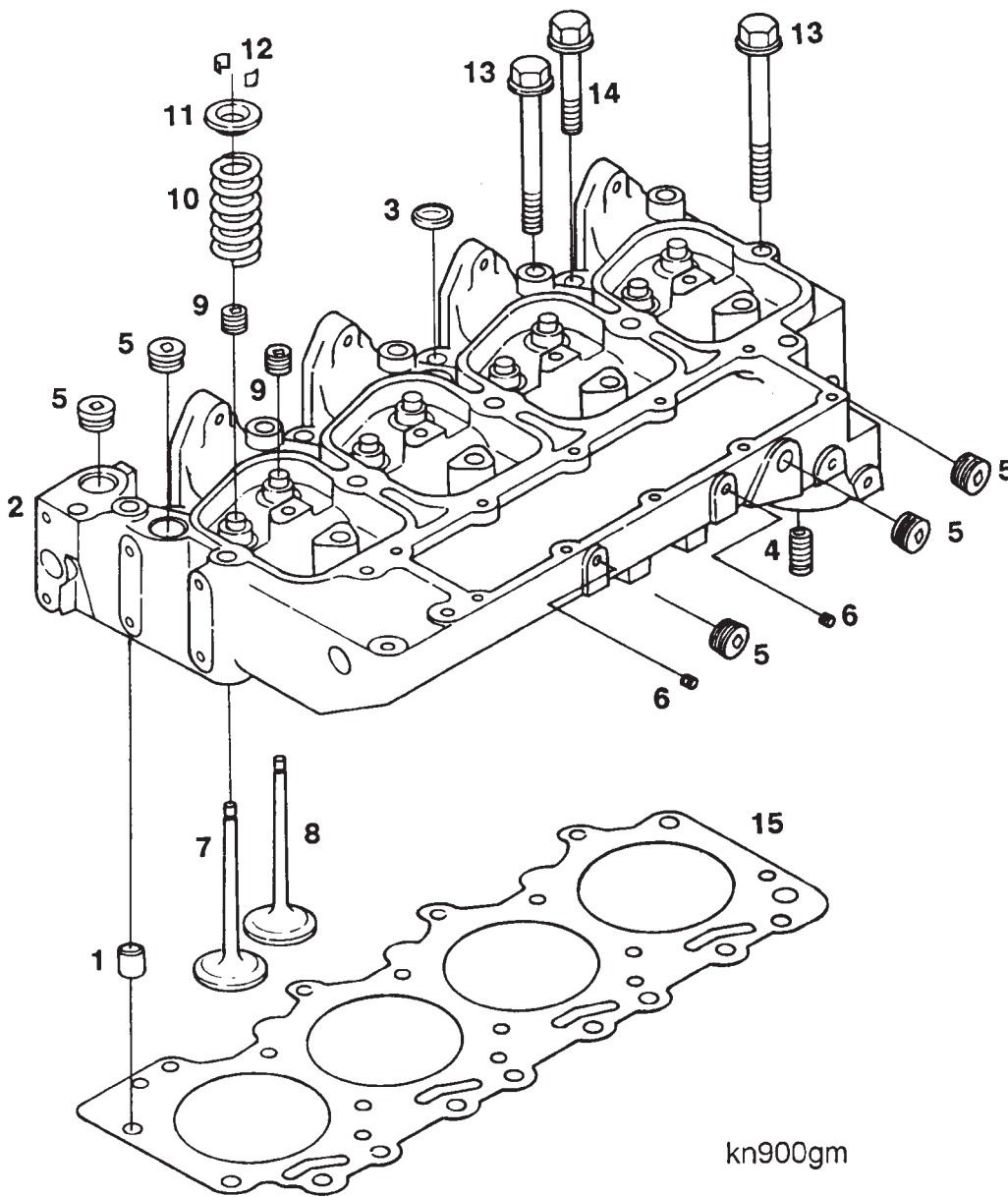

Ref. No	Part Name	Qty.	Remarks
1	Dowel, Ring	1	Reference Only.
2	Cylinder Head	1	
3	Plug, Expansion	3	13/16 in.
4	Insert, Fuel Filter	1	Reference Only
5	Plug, Pipe	4	1/2 in. NPTF
6	Plug, Pipe	2	1/8 in. NPTF
7	Valve, Intake	4	
8	Valve, Exhaust	4	
9	Seal, Valve	8	
10	Spring, Valve	8	
11	Retainer, Valve Spring	8	
12	Collet, Valve Half	16	
13	Screw, Hex Head Cap	10	M12-1.75x120
14	Screw, Hex Head Cap	4	M12-1.75x70
15	Gasket, Cylinder Head	1	

## General Information

The cylinder head is a one piece, crossflow design with two valves per cylinder. The cylinder head features integrally cast valve guides, induction hardened seat surfaces, integral intake manifold, fuel filter head, and thermostat housing. On high horsepower automotive six cylinder engines equipped with in-line injection pumps, the fuel filter head is eliminated to allow for adequate injection pump clearance. The fuel filter head bracket is relocated to allow for adequate injection pump clearance. The injectors are mounted in the cylinder head for direct injection into the cylinders.

The cylinder head gasket is a composite design with a fire ring to seal the cylinder bores. Orifices in the gasket control coolant flow.

The valve seats can be re-ground once. Valve seats that have been previously re-ground can be replaced with service valve seats. Service valve guides are also available to replace worn guides. Refer to the Alternative Repair Manual, Bulletin No. 3810234, for seat and guide replacement procedures.

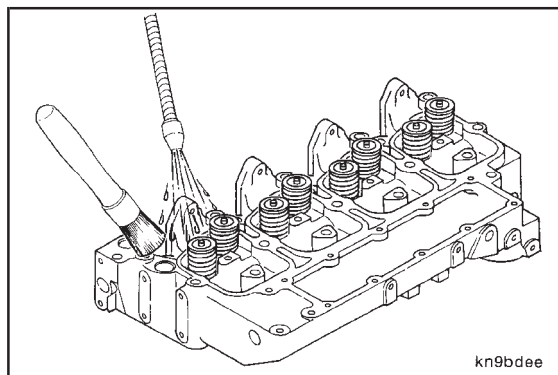

### Cylinder Head - Precheck Before Disassembly (2-01)

Clean the cylinder head with solvent.

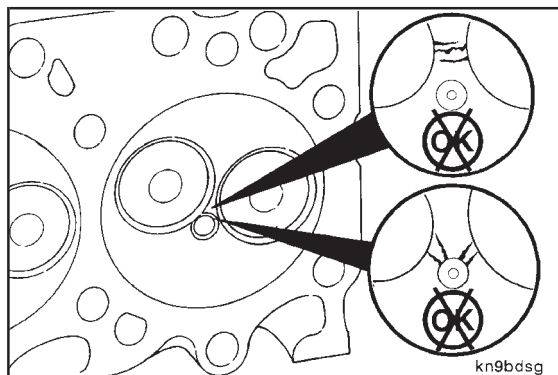

Visually inspect the cylinder head for obvious damage that would prohibit reuse. Check for cracks and damage to the combustion face that would result in loss of sealing.

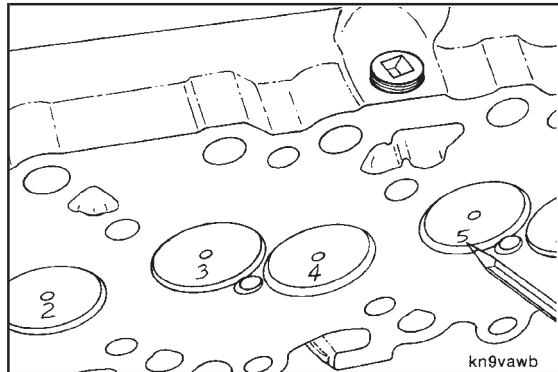

### Cylinder Head - Disassembly (2-02)

Mark the valves to identify their position.

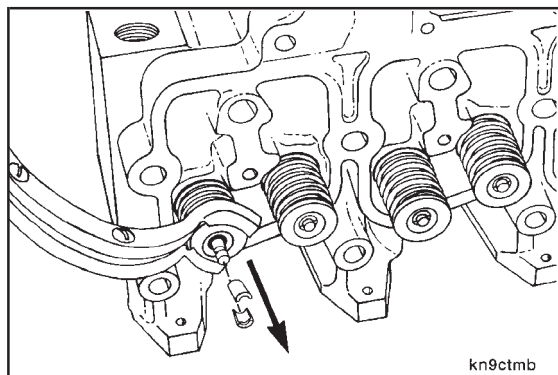

Compress the valve spring and remove the valve stem collets.

Release valve spring and remove the retainer and spring.

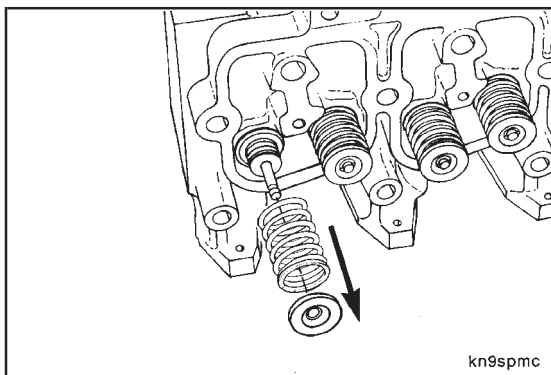

Remove the remaining collets, retainers, springs and valves.

**Keep the valves in a labeled rack for a correct match with companion seats while making measurements.**

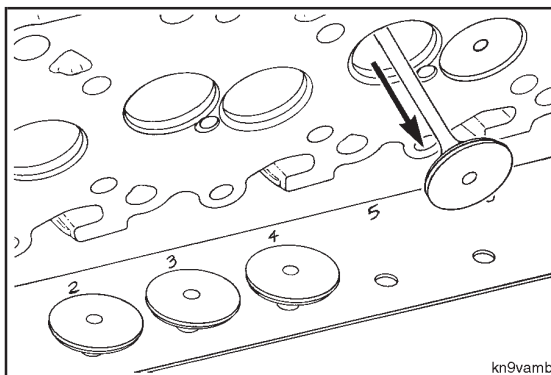

Remove the valve stem seals.

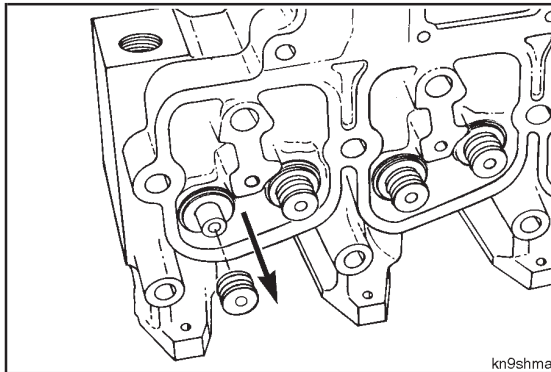

## Cylinder Head - Cleaning (2-03)

### Injector Bore Brush 3822509

Clean the carbon from the injector nozzle seat.

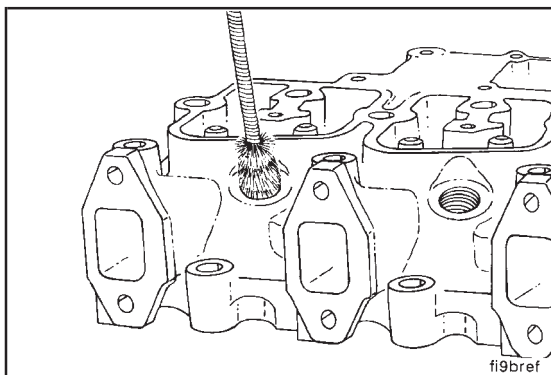



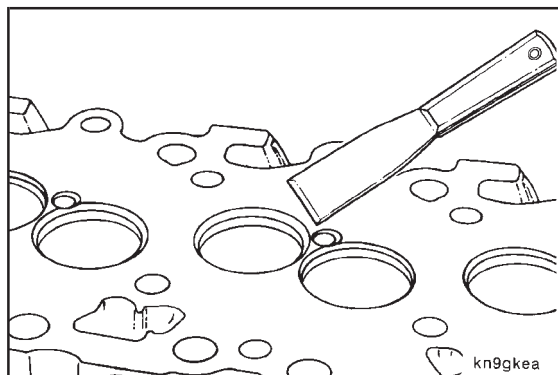

Scrape the gasket material from all gasket surfaces.

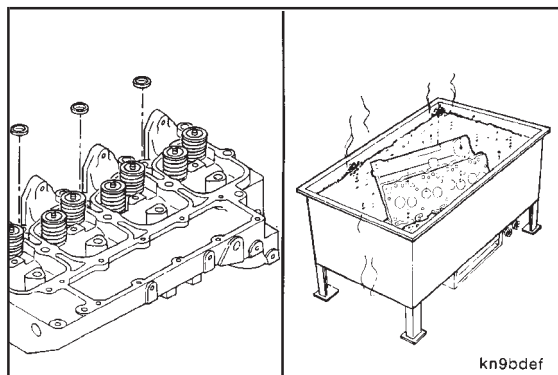

Clean the build-up of deposits from the coolant passages. Excessive deposits may be cleaned in an acid tank but the cup plugs must first be removed. Refer to Cup Plug Replacement procedure (2-10).

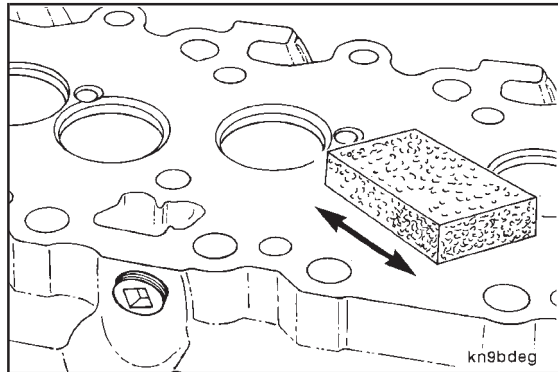

Clean the combustion face with a Scotch-Brite® pad or an equivalent cleaning pad and diesel fuel or solvent.

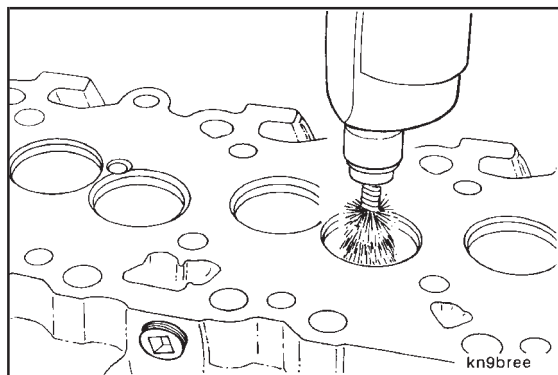

**Warning:** Wear protective eye covering.



Clean carbon deposits from the valve pockets with a high quality steel wire wheel installed in a drill or a die grinder.

**NOTE:** An inferior quality wire wheel will loose steel bristles during operation, thus causing additional contamination.

Wash the cylinder head in hot soapy water solution.  
After rinsing, use compressed air to dry the cylinder head.

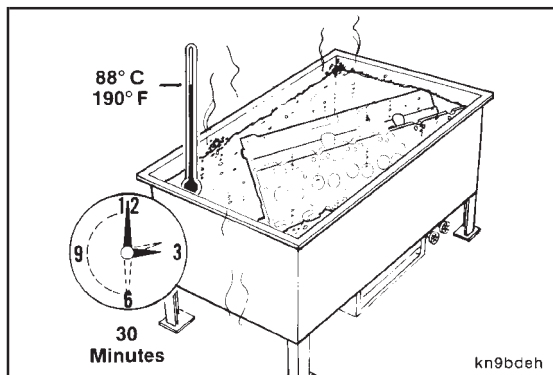

**Warning: Wear protective eye covering.**  
Clean the valve heads with a soft wire wheel.  
**Keep the valves in a labeled rack to prevent mixing prior to making measurements.**

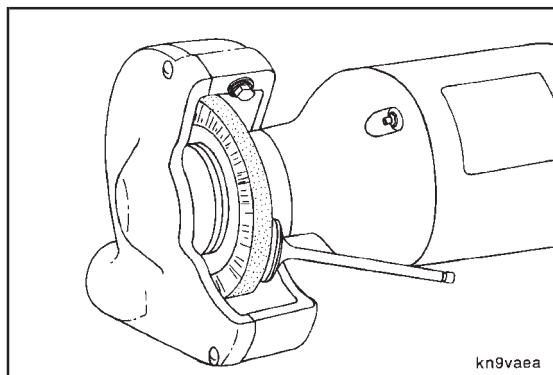

Polish the valve stem with a Scotch-Brite® pad or equivalent cleaning pad and diesel fuel or solvent.

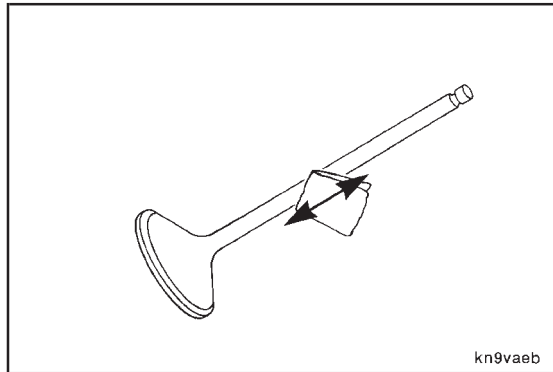

**Valve - Inspection (2-04)**

Inspect for abnormal wear on the heads and stems.

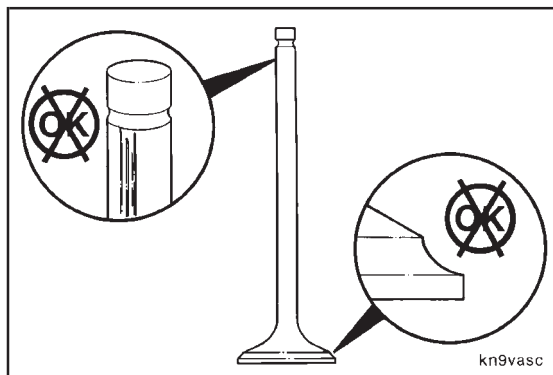

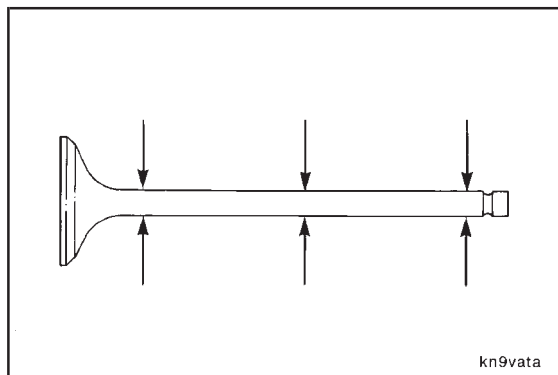

Measure the valve stem diameter.

Valve Stem Diameter		
mm		in
7.94	MIN	0.3126
7.98	MAX	0.3142

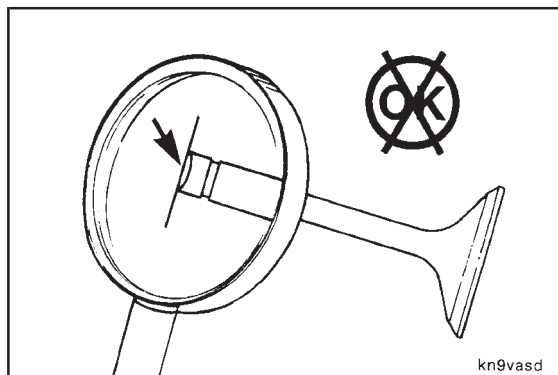

Check the valve stem tip for flatness.

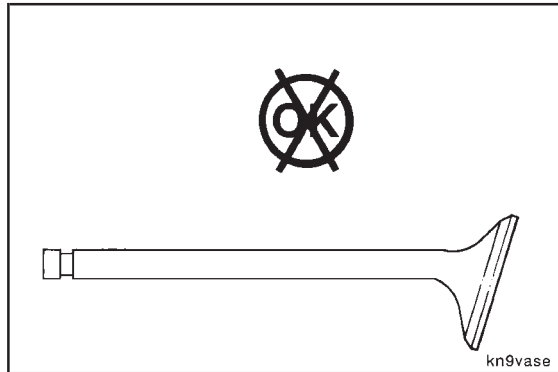

Visually inspect for bent valves.

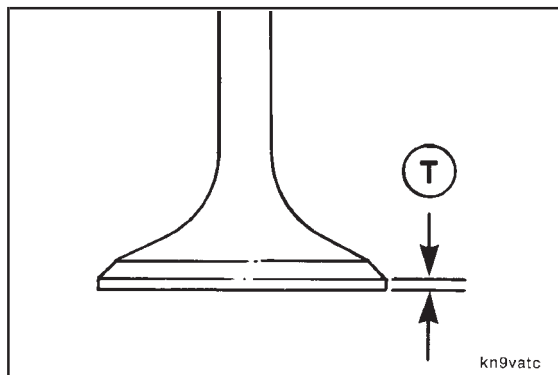

Measure the rim thickness to determine if there is enough stock to grind the valve.

**Limits**

**Minimum (T):** 0.79 mm [0.031 in].

If the valves are determined to be suitable for resurfacing refer to the valve grinding procedures on page 2-13.

### Valve Guide Inspection (2-05)

Inspect the valve guides for scuffing or scoring.  
Measure the valve guide bore.

Valve Guide Bore Diameter		
mm		in
8.019	MIN	0.3157
8.090	MAX	0.3185

If the inspection reveals damaged valve guides, refer to the Alternative Repair Manual, Bulletin No. 3810234.

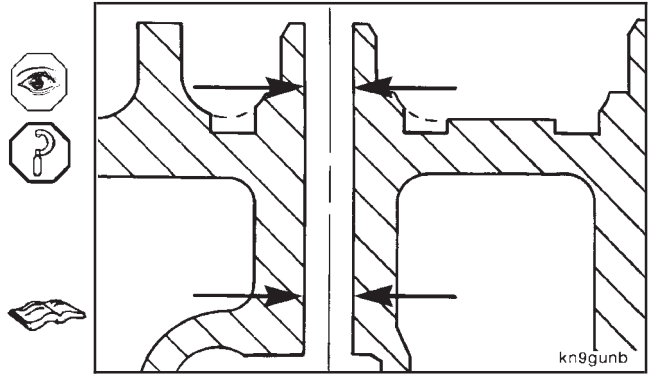

### Cylinder Head Combustion Face Inspection (2-06)

Visually inspect the cylinder head combustion surfaces for any irregularities (dents, guttering, fire ring embedment, etc.). If any of these conditions exist, the surface must be machined in accordance with the appropriate procedure from the Alternative Repair Manual, Bulletin No. 3810234.

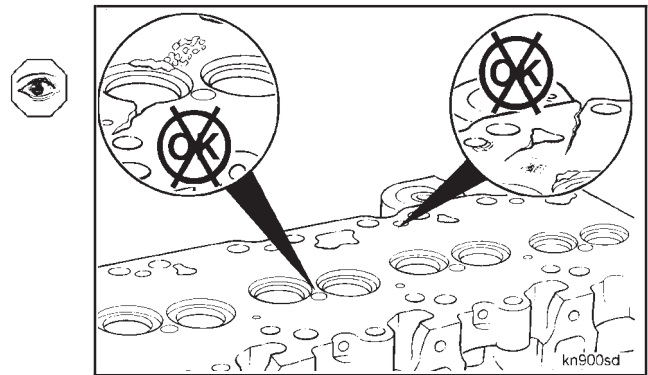

Measure the cylinder head overall flatness:

End-to-End 0.305 mm [0.012 in] (6B)  
0.203 mm [0.008 in.] (4B)

Side-to-Side 0.076 mm [0.003 in]

Visually inspect for any localized dips or imperfections. If present, the cylinder head deck must be reground.

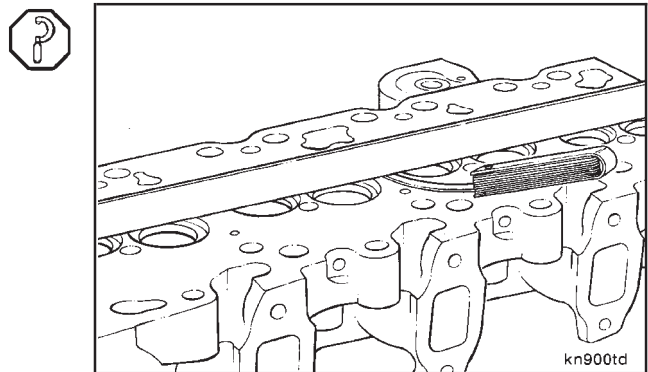

### Valve Seat Inspection (2-07)

Inspect the valve seats for cracks or burned spots.

Refer to the following reuse guidelines for any cracks discovered. Service valve seats are available for seats with burned spots that will require more than 0.254 mm [0.010 in] grinding to clean up. Refer to the Alternative Repair Manual, Bulletin No. 3810234, for valve seat installation procedures.

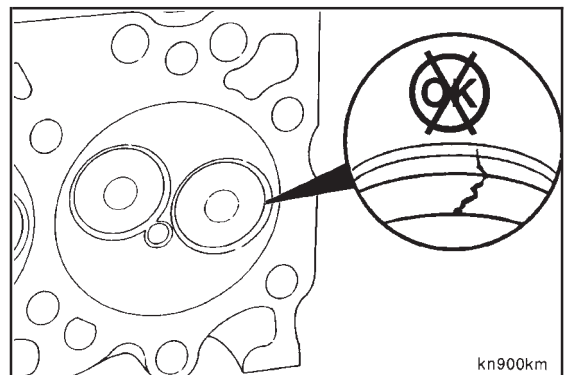

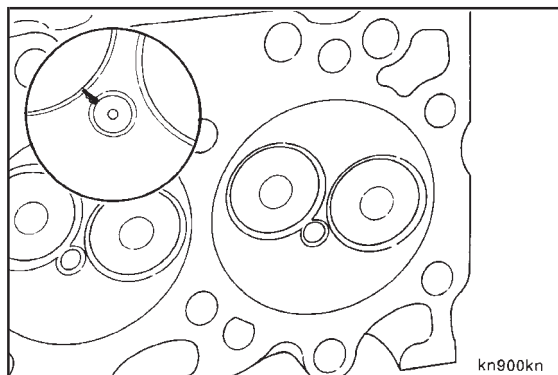

### Cylinder Head Cracks - Reuse Guidelines (2-08)

These guidelines apply **only** to cracks extending through the valve seats.

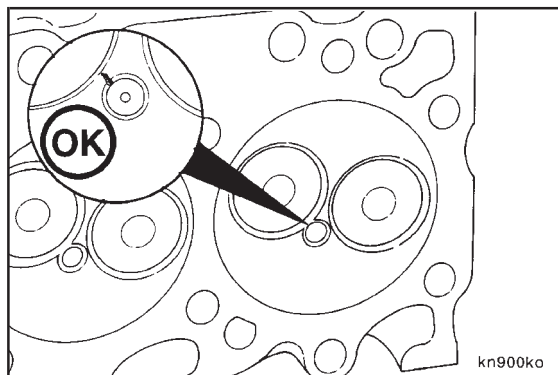

The reuse guidelines for a cylinder head with a crack extending from the injector bore to the valve seat is as follows:

If the crack does not extend into the valve seat, the head is reusable.

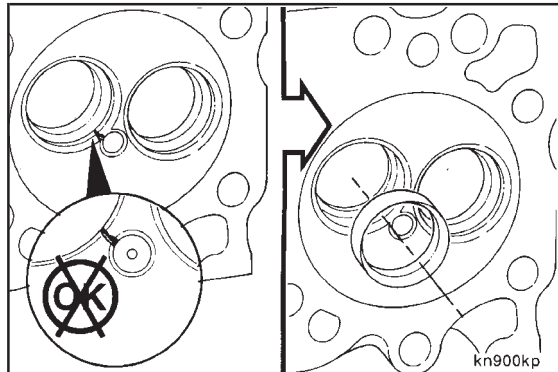

If the crack extends into or through the valve seat, the head must be repaired by installing a valve seat insert per the Alternative Repair Manual, Bulletin No. 3810234.

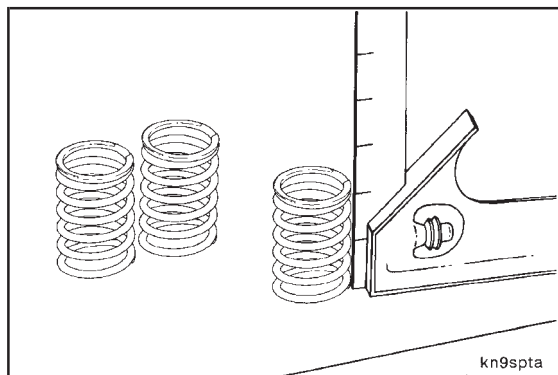

### Valve Spring Inspection (2-09)

Inspect the Valve Springs.

Measure the valve spring.

Limits

Approx. Free Length (L): 55.63 mm [2.190 in.]

Maximum Inclination: 1.0 mm [0.039 in.]

**Spring Specifications**

Spring Color	Approximate Free Length	Load at 49.25mm Height
Blue	55.63mm [2.190 in]	289.13 to 321.16 N [65.0 to 72.2 Lbs]
White	70.64mm [2.781 in]	643.2 to 691.2 N [144.6 to 155.4 Lbs]

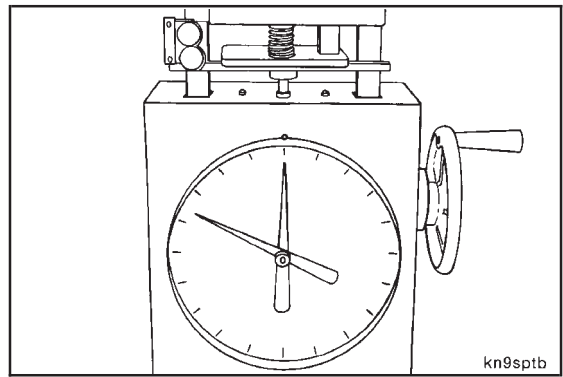

kn9sptb

**Cup Plug Replacement (2-10)**

Drill Motor, 3 mm [1/8 inch] drill bit, slide hammer, #10 metal screw.

Remove the cup plugs from the cylinder head.

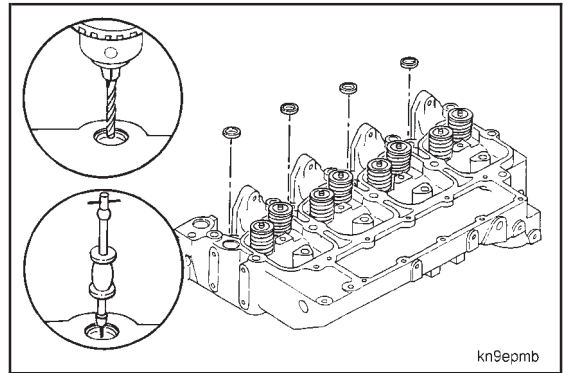

kn9epmb

**400 grit sandpaper, Diesel Fuel**

Thoroughly clean the cup plug holes.

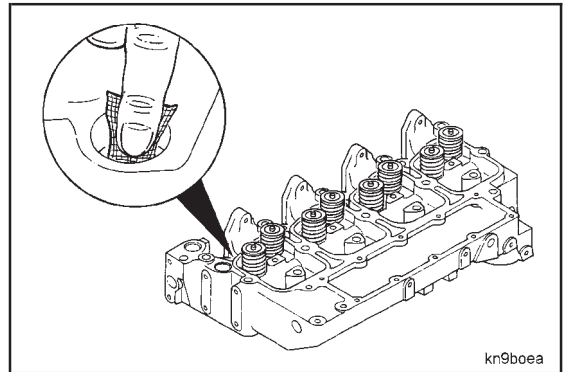

kn9boea

**Caution: Use protective clothing to prevent personal injury.**

Inspect for build-up of deposits in the coolant passages which can cause engine overheating.

Be sure the coolant passages are clean.

Excessive deposits may be cleaned in an acid tank, but the cylinder head must be disassembled first.

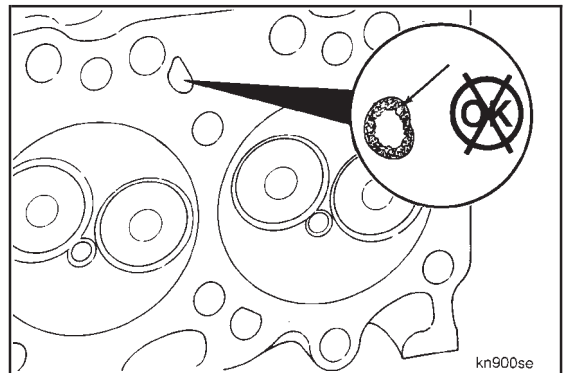

kn900se

Cup Plug Replacement (2-10)  
Page 2-14

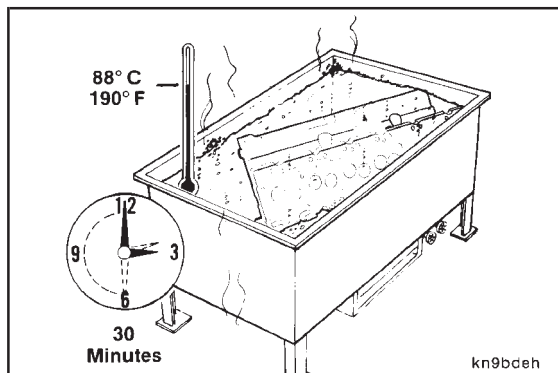

**Caution:** Use protective clothing to prevent personal injury.

The cylinder head may be cleaned in a hot tank using a soap and water solution.

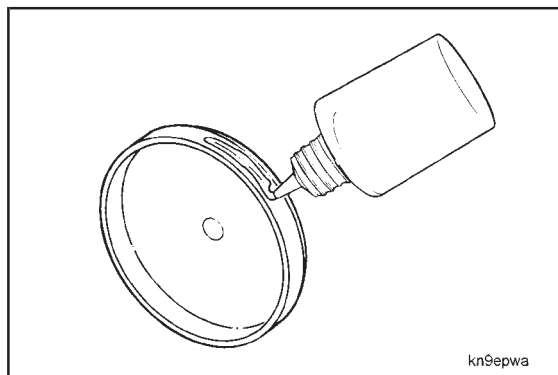

**NOTE:** The cup plugs and cup plug holes must be clean and free of oil before installing the cup plugs.

Apply a bead of Loctite™ 277 around the outside diameter of all cup plugs before installing.

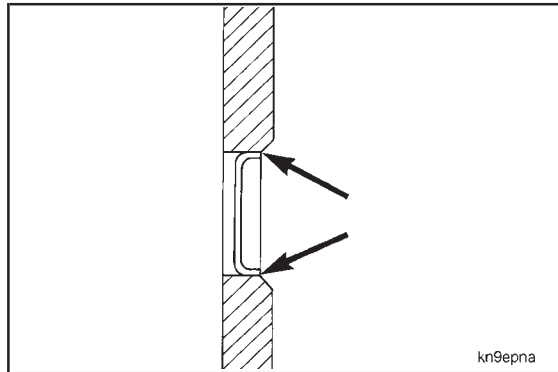

**Cup Plug Driver Part No. 3900965**

Drive all cup plugs in until the outer edge is flush with the counter sink.

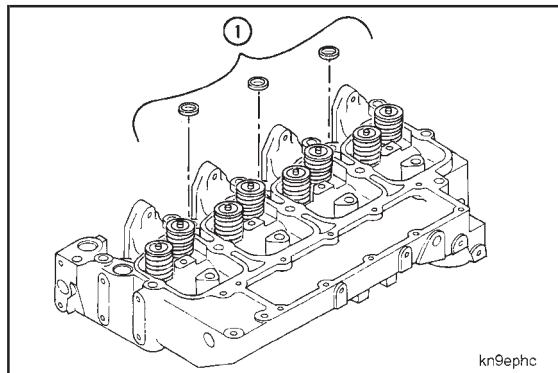

**Cup Plug Locations**

1. 13/16 inch

### Valves - Grinding (2-11)

Re-face all reused valves. Check/replace bent valves.

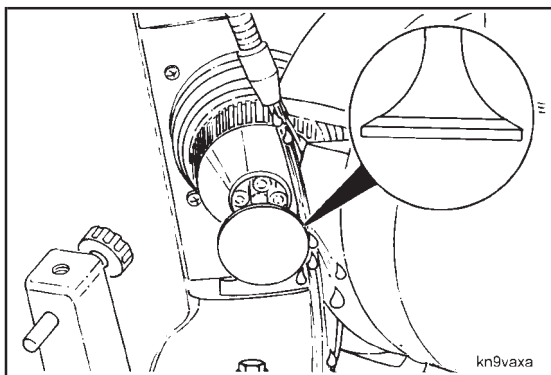

#### Seat Angle

Intake: 30 Degrees

Exhaust: 45 Degrees

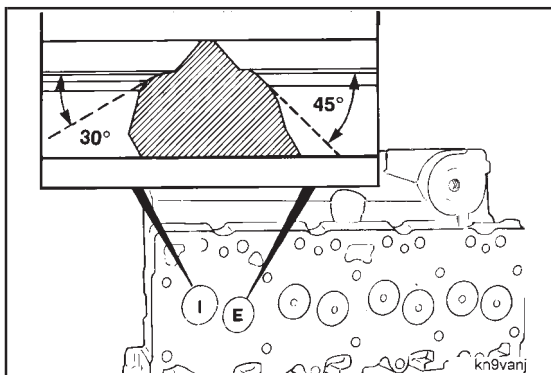

Measure rim thickness.

#### Valve Rim Thickness

Minimum (T): 0.79 mm [0.031 in]

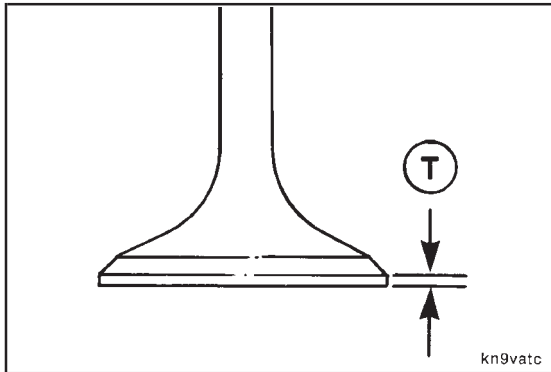

Check the valve stem tip for flatness.

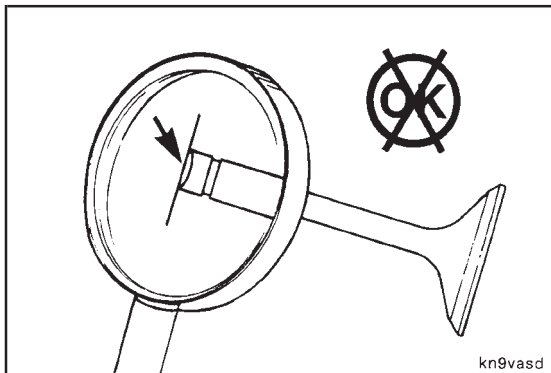



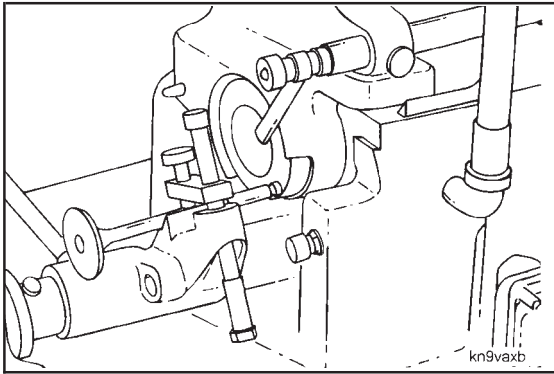

If required, re-surface the tip.

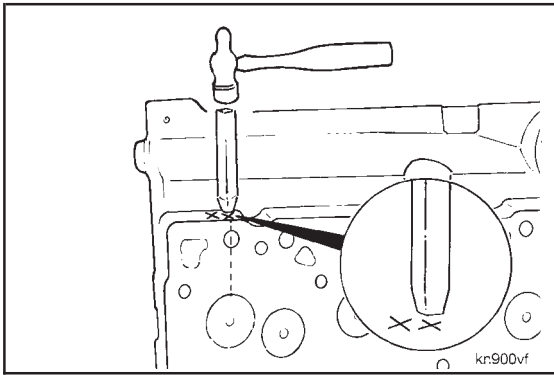

### Valve Seats - Grinding (2-12)

The illustrated marks indicate valve seats have been ground previously. Additional grinding will result in grinding past the induction hardened area.

Replace previously re-ground seats with service seats. Refer to the Alternative Repair Manual, Bulletin No. 3810234.

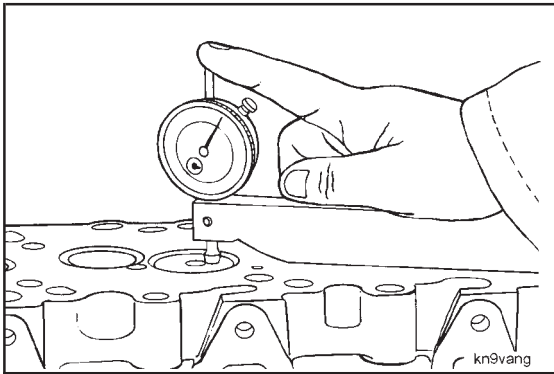

### Calculating the Grinding Depth

#### Measuring the Valve Depth



#### 3823495 Gauge Block



Install the valves in their designated location and measure the valve depth.

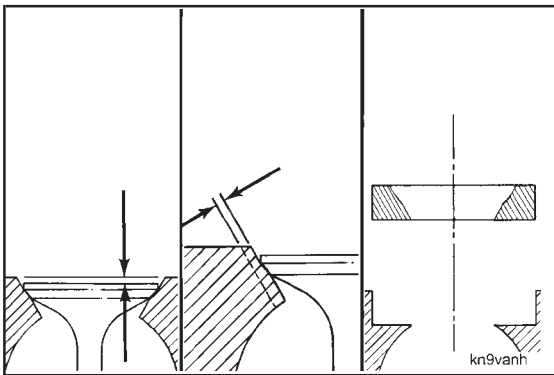

There are two valve seat parameters that are critical to the valve grinding process. The first is to comply with the valve depth limits and the second is to not grind through the hardened layer of the valve seat by observing the grind depth limit. If either of these parameters are out of specification, refer to the "Alternative Repair Manual," Bulletin No. 3810234.

The valve depth is the distance from the valve face to the head deck.

Record the depth of each valve as (A).

Valve Depth		
mm		in
0.99	MIN	0.039
1.52	MAX	0.060

If valve depth does not meet specification the valve seat must be replaced.

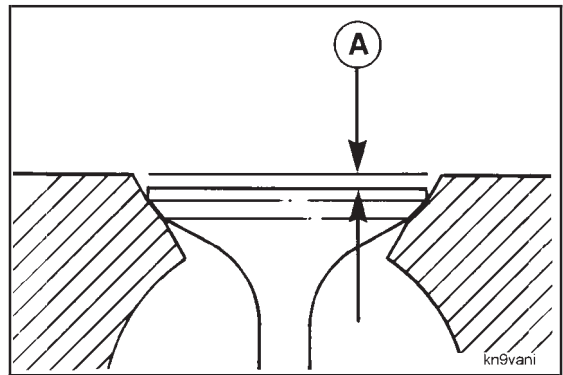

After valves meet initial valve depth criteria, grind the valve seats to remove all scores, scratches and burns.

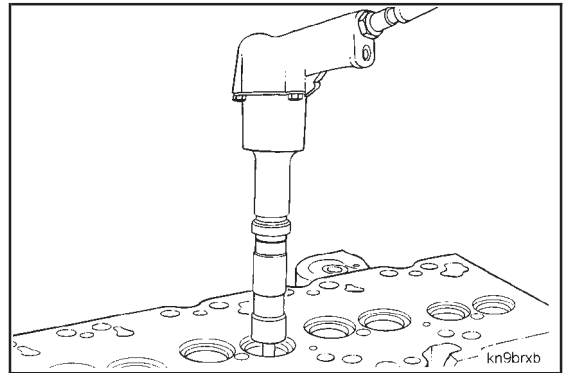

**Seat Angle**

**Intake:** 30 Degrees

**Exhaust:** 45 Degrees

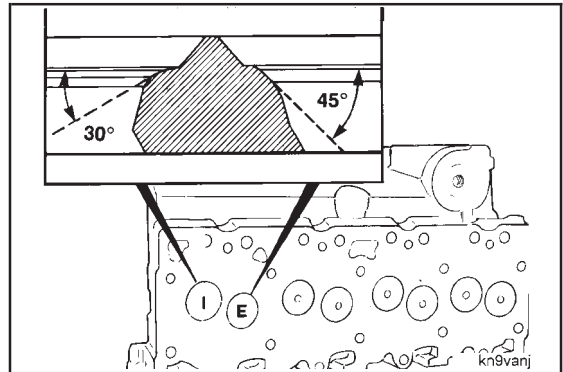

**3823495 Gauge Block**

Since the seats have been ground, it is necessary to re-measure the valve depth and to calculate the grinding depth.

Install the valves in their respective bores and measure the depth. Record the depth of each valve as (B).

**Make sure the seats are clean before you measure the depth.**

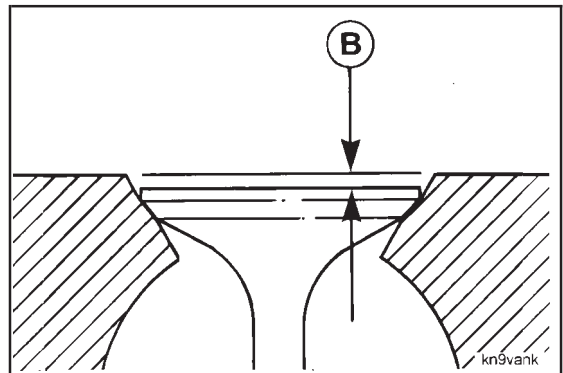

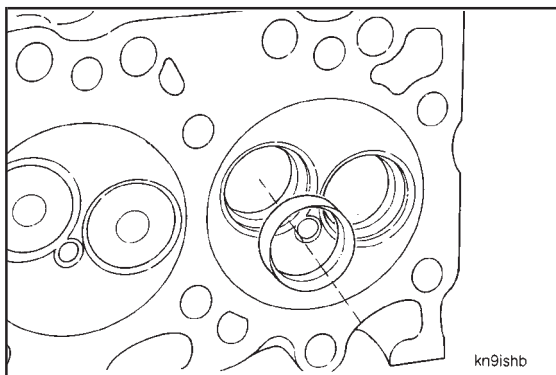

Calculate grinding depth (GD) as follows:

$$GD = (B) - (A)$$

**Seat Grinding Depth Limit**

GD: 0.254 mm [0.010 inch]

Service valve seats are available for over the limit seats.

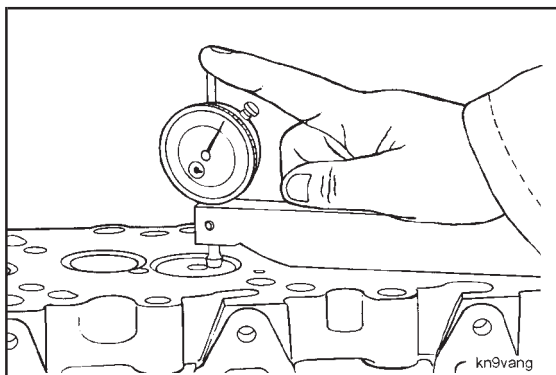

Confirm that the valve depth after grind (B) is still within the original specification.

Valve Depth (A) or (B)		
mm		in
0.99	MIN	.039
1.52	MAX	.060

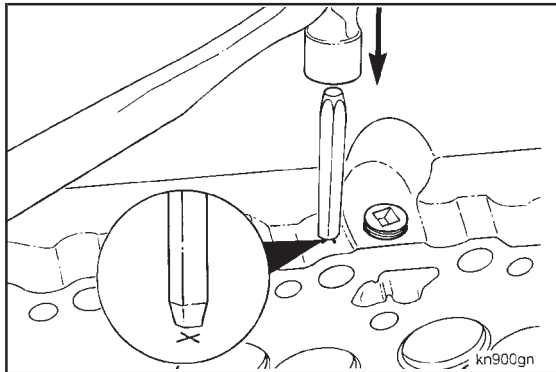

Mark the cylinder head with an (X) to identify each re-ground valve seat.

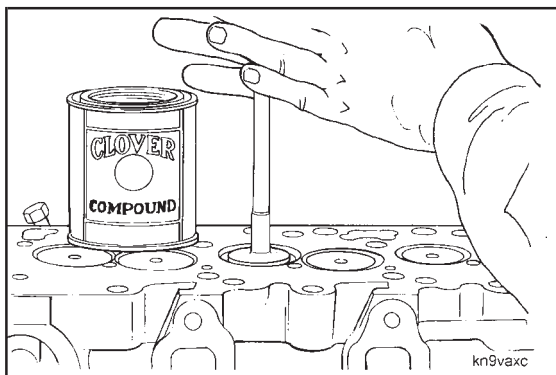

Apply a light coat of valve lapping compound to each valve and lap each valve to its companion seat.

Remove the valves and clean the lapping compound from the valves and seats.

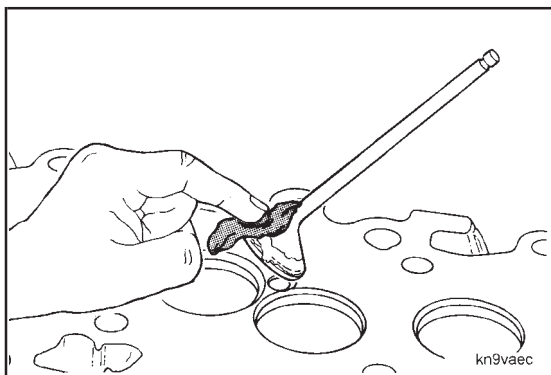

The valve should seat in the center of the valve face. Measure the valve seat width indicated by the lapped surface.



Valve Seat Width Limit		
mm		in
1.5	MIN (1)	0.059
2.0	MAX (2)	0.079

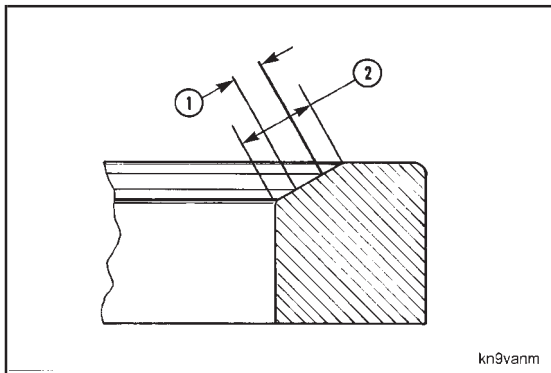

Grind area (A) with a 60 degree stone and (B) with a 15 degree stone to center the seat on the valve face and obtain the valve seat width limits.



Valve Seat Width Limit		
mm		in
1.5	MIN	.059
2.0	MAX	.079

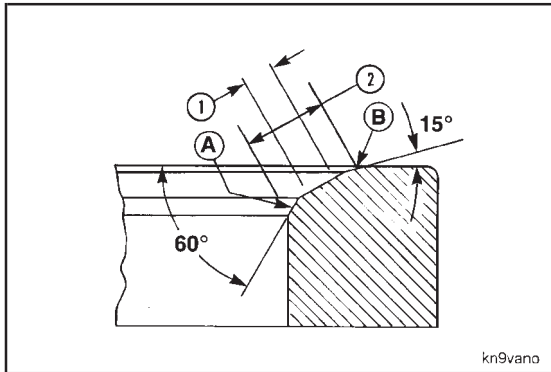

The lapped surface on the valve face is the key to determining how much of each angle to grind.

If the lapped surface is at the bottom of the valve face, the seat will require more grinding with the 60 degree stone than with the 15 degree stone.

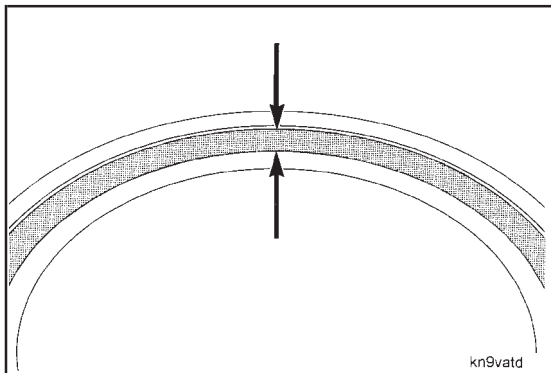

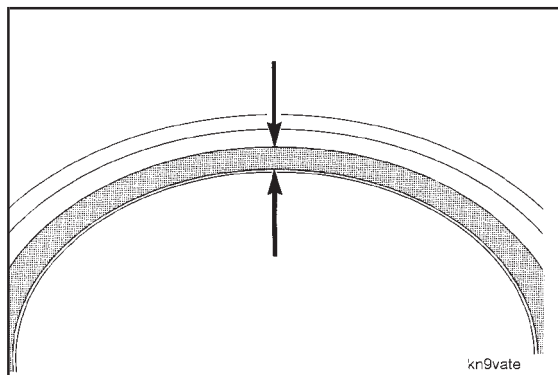

If the lapped surface is at the top of the valve face, the seat will require more grinding with the 15 degree stone than with the 60 degree stone.

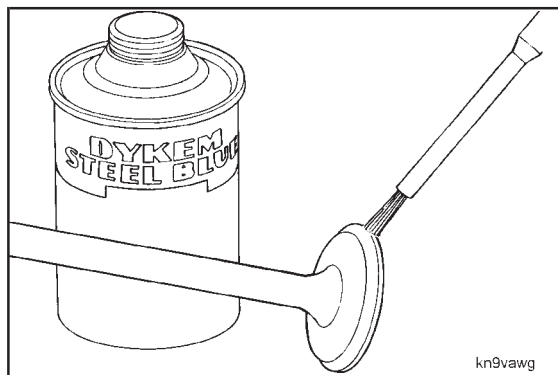

After centering the seat on the valve face, coat the valve face with Dykem™ Steel Blue™ and allow to dry.

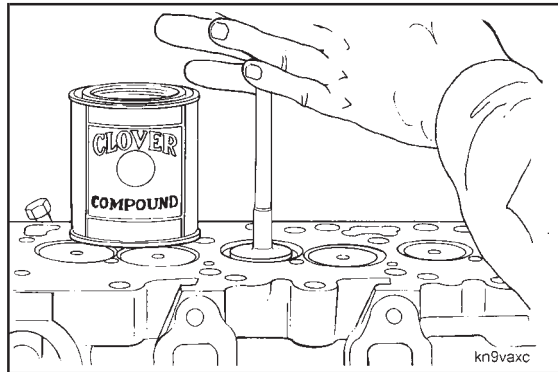

Apply a coat of valve lapping compound to the valve and lap the valve to its companion seat.

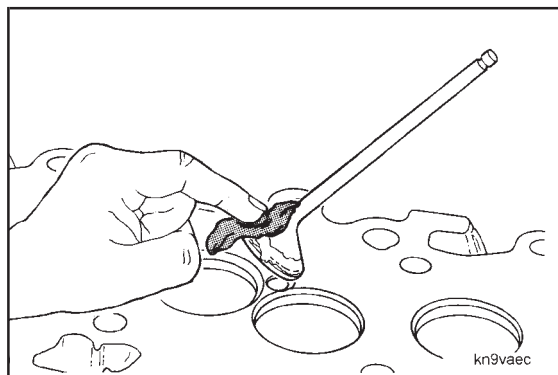

Remove the valve and clean the lapping compound from the valve face and seat.

Inspect the valve face for seat width and centering.

Valve Seat Width		
mm		in
1.5	MIN	.059
2.0	MAX	.079

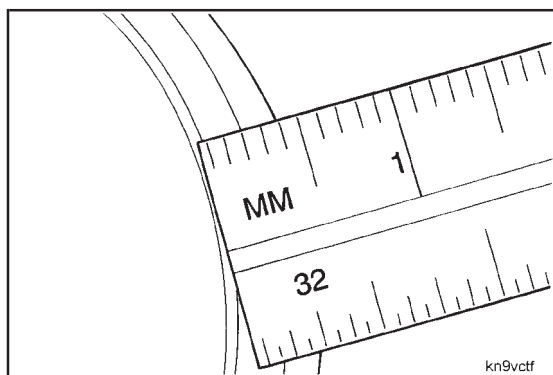

### Cylinder Head - Assembly (2-13)

**NOTE:** Clean all cylinder head components before assembling.

Install the valve stem seals.

The intake and exhaust seals are the same.

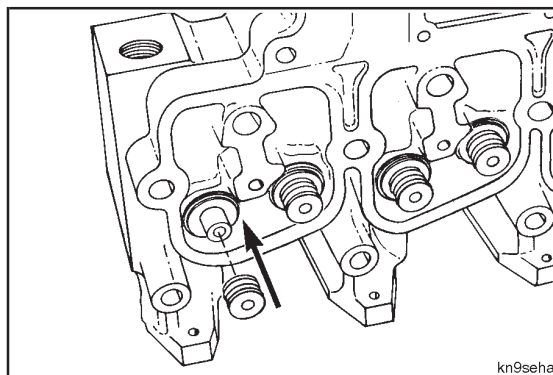

Lubricate the stems with SAE 90W engine oil before installing the valves.

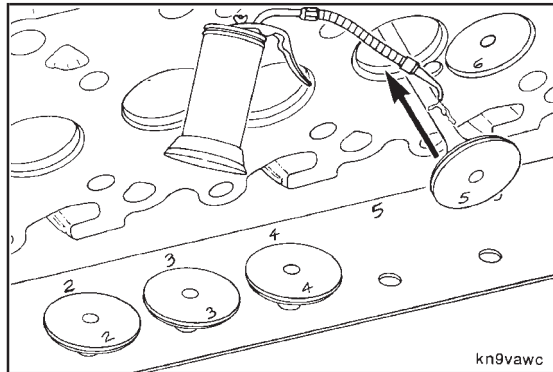

### Valve Spring Compressor

Compress the valve spring after assembling the spring and retainer.

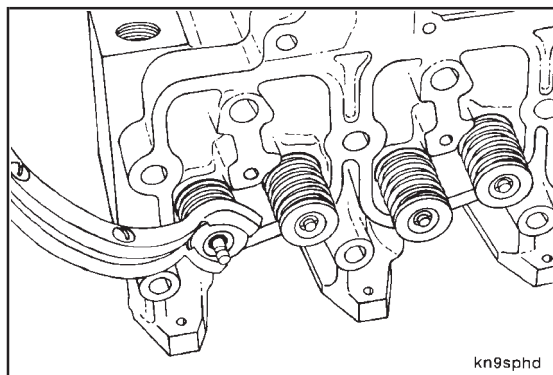

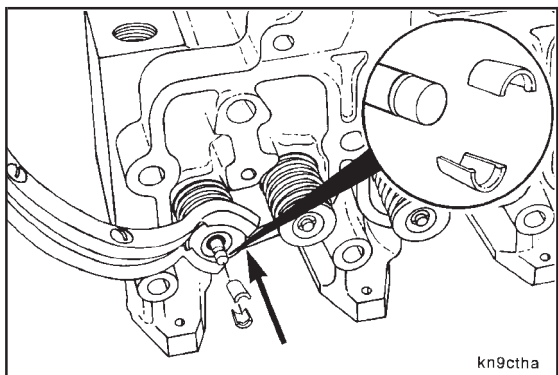

Install new valve collets and release the spring tension.

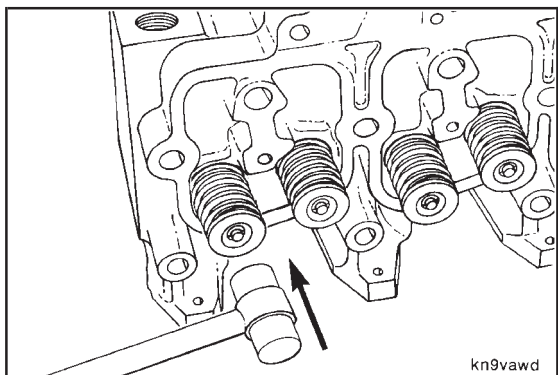

**Plastic Hammer**



**Warning:** Wear eye protection. If the collets are not correctly installed, they can fly out when the stems are hit with a hammer.

After assembly, hit the valve stems with a plastic hammer to make sure that the collets are seated.

# Section 3 - Rocker Levers - Group 03

## Section Contents

	Page
Rocker Lever - Inspection.....	3-6
Rocker Lever Assembly - Exploded View.....	3-2
Rocker Lever Assembly - General Information .....	3-4
Rocker Lever Pedestals - Inspection .....	3-7
Rocker Levers - Assembly .....	3-7
Rocker Levers - Disassembly .....	3-5
Rocker Levers and Pedestals - Cleaning.....	3-6



### Rocker Lever Assembly - Exploded View

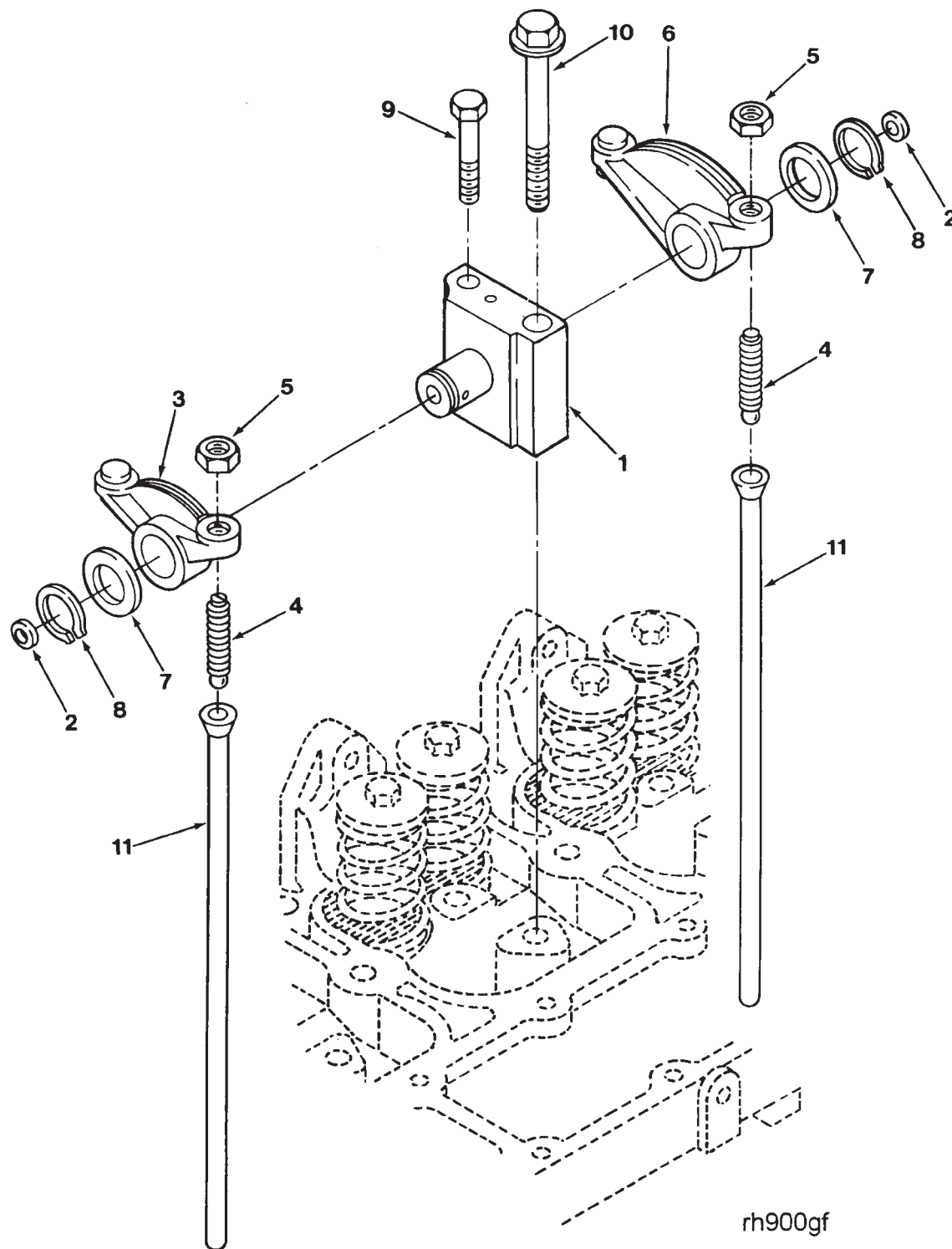

Ref. No.	Part Name	Req.	Remarks
1	Support, Rocker Lever	4	
2	Plug, Expansion	8	
3	Lever, Rocker (Intake)	4	
4	Screw, Slotted Set	4	3/8 inch - 24 UNF - 2A
5	Nut, Regular Hexagon	4	
6	Lever, Rocker (Exhaust)	4	
7	Washer, Plain	8	
8	Ring, Retaining	8	
9	Screw, Hexagon Head Cap	4	M8 - 1.25 x 75mm
10	Screw, Hexagon Head Cap	4	M12 - 1.75 x 180mm
11	Rod, Push	8	

## Rocker Lever Assembly - General Information

Each cylinder of the engine has a separate rocker lever assembly. The assembly consists of the intake rocker lever, exhaust rocker lever, rocker lever shaft and pedestal support. The pedestal support has drillings to route the oil flow to the shaft and levers.

The levers are push rod actuated and use an adjusting screw to control the clearance between the lever and valve stem. The levers do not use a bushing in the bore for the rocker lever shaft. The lever must be replaced if the bore is damaged or worn beyond the limit.

### Rocker Levers - Disassembly (3-01)

#### Snap Ring Pliers

Remove the retaining rings and thrust washers.

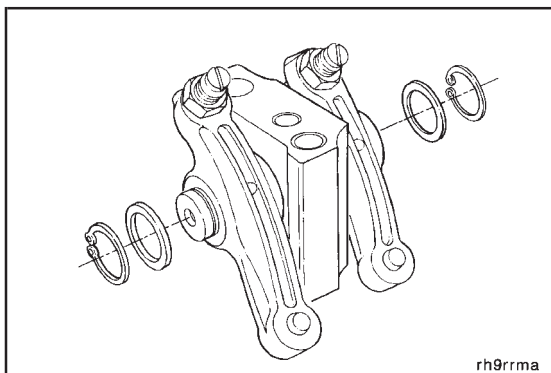

Remove rocker levers

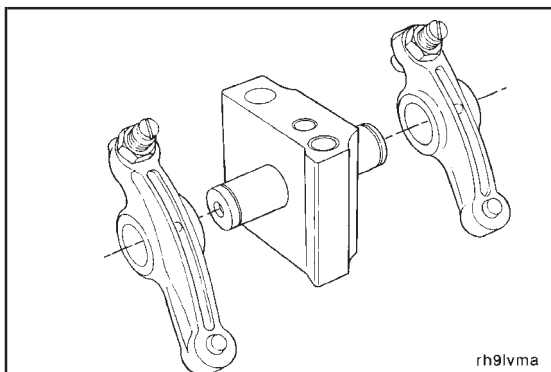

The rocker shaft and pedestals are serviced as an assembly. **Do not disassemble.**

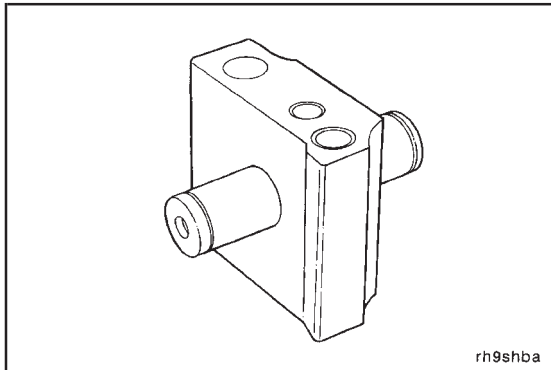

Remove the locknut and adjusting screw.

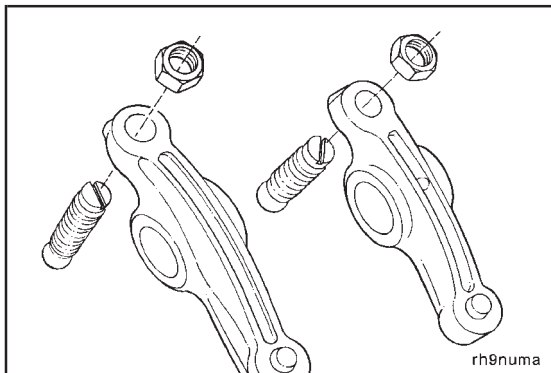

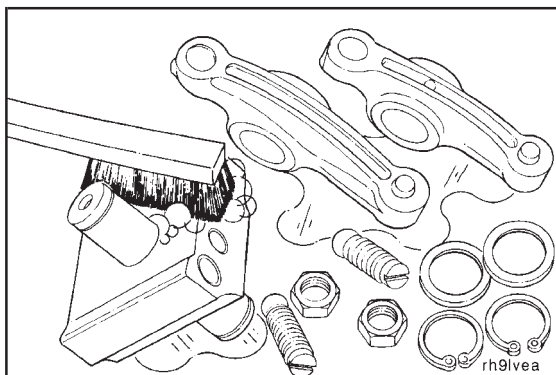

### Rocker Levers and Pedestals - Cleaning (3-02)

Clean all parts in a strong solution of laundry detergent in hot water.

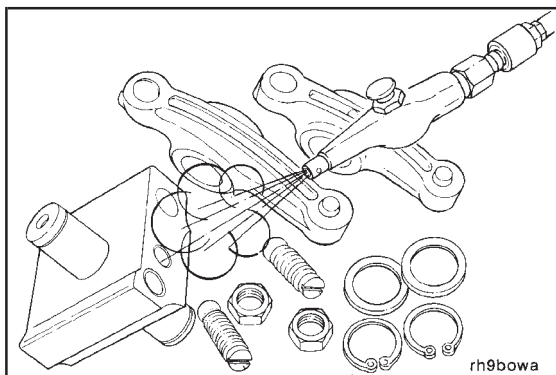

Use compressed air to dry the parts after rinsing in clean, hot water.

**NOTE:** The pedestals are made from powdered metal and will continue to show wetness after they have been cleaned and dried.

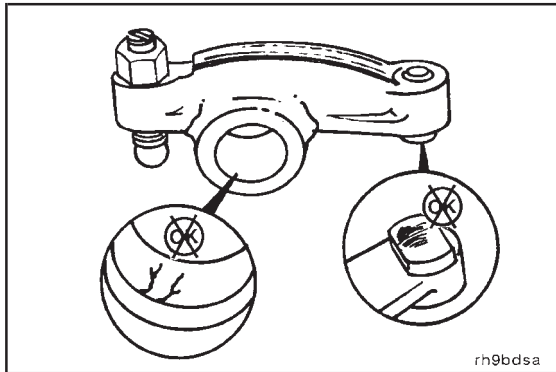

### Rocker Lever - Inspection (3-03)

Inspect for cracks and excessive wear in the bore and the contact surface for the valve stem.

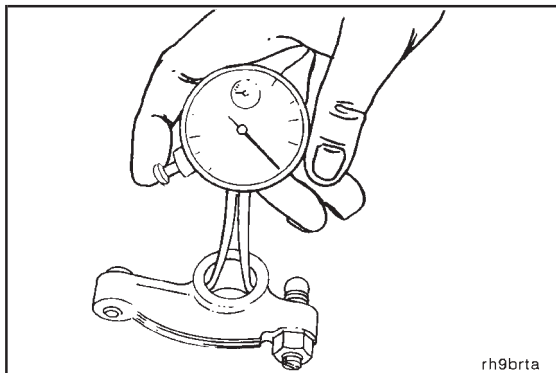

Measure the rocker lever bore.

Diameter		
mm		in
19.000	MIN	[0.7480]
19.051	MAX	[0.7500]

### Rocker Lever Pedestals - Inspection (3-04)

Inspect the pedestal and shaft for obvious damage.  
Measure the shaft diameter.

		Diameter	
mm		MIN	in
18.938			[0.7456]
18.975		MAX	[0.7470]

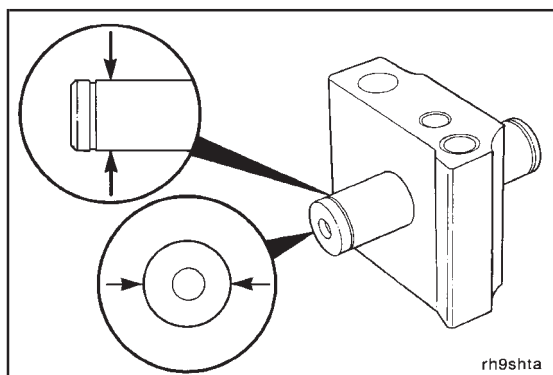

rh9shta

### Rocker Levers - Assembly (3-05)

Install the adjusting screw and locknut.

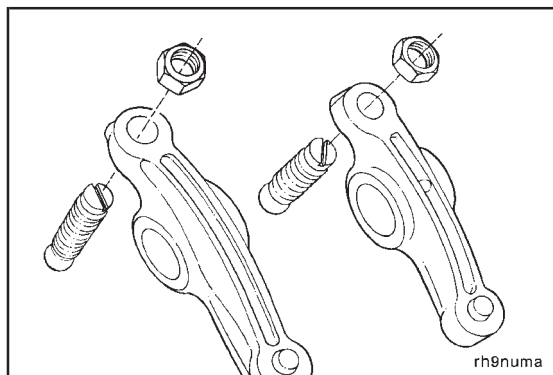

rh9numa

Lubricate the shaft with clean engine oil.

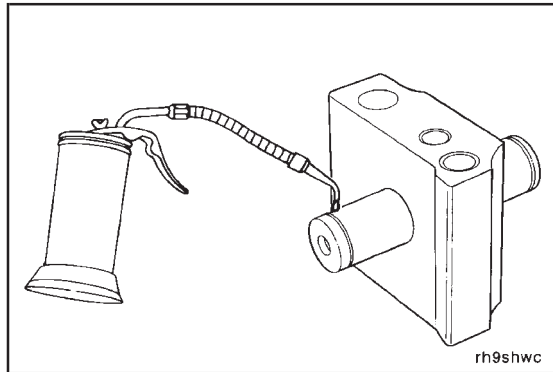

rh9shwc

Position the levers on the rocker shaft.

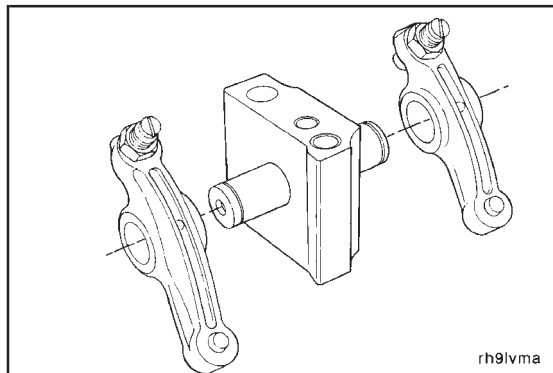

rh9lvma

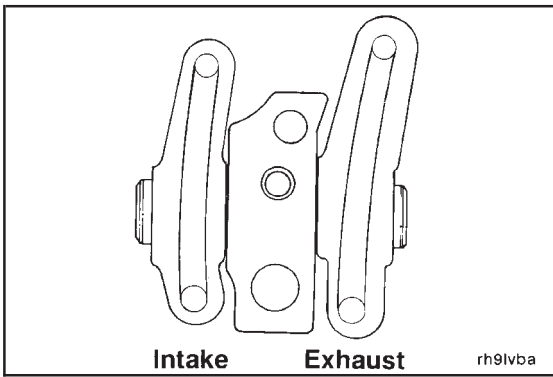

Be sure to assemble the intake and exhaust rocker levers in the correct location.

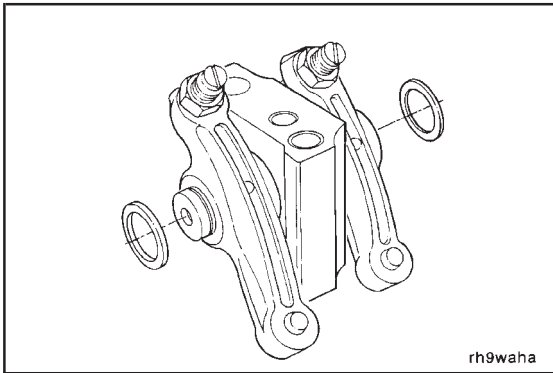

Install the thrust washers.

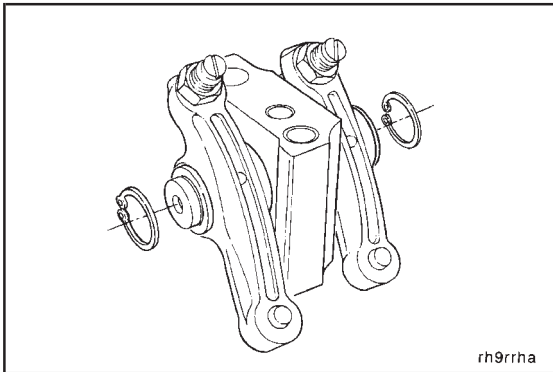

**Snap Ring Pliers**

Install the snap rings.



# Section 4 - Tappets and Push Rods - Group 04

## Section Contents

	Page
<b>Push Rods - Inspection</b> .....	4-4
<b>Tappets and Push Rods - Exploded View</b> .....	4-2
General Information.....	4-3
Tappets and Push Rods - General Information.....	4-3
<b>Valve Tappets - Inspection</b> .....	4-4



### Tappets and Push Rods - Exploded View

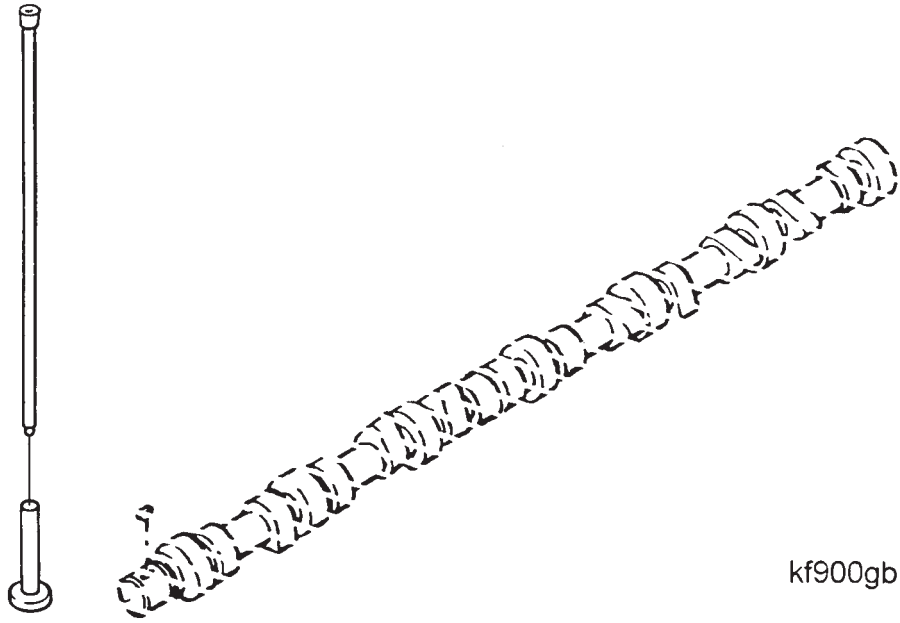

kf900gb

**Tappets and Push Rods - General Information**

**General Information**

The camshaft has lobes to operate the intake and exhaust valves and a special lobe to drive the lift pump. The valve lobes contact the valve tappets which lift the push rods subsequently opening the valves.

The tappets are mushroom shaped and are positioned so the centerline of the tappet is offset to the centerline of the cam lobe. The offset position causes the tappet to rotate as it lifts the push rod.

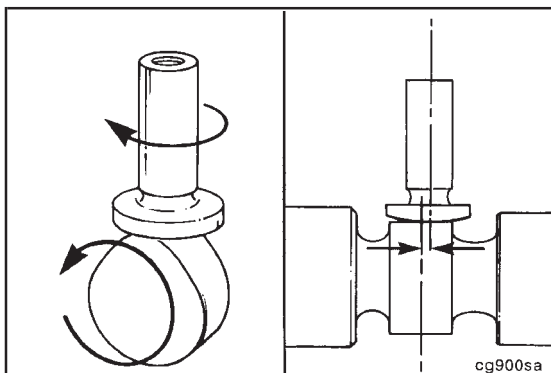

cg900sa

The ball end of the push rod fits into the ball socket in the tappet. The other end of the push rod has a ball socket in which the ball end of the rocker lever adjusting screw operates.

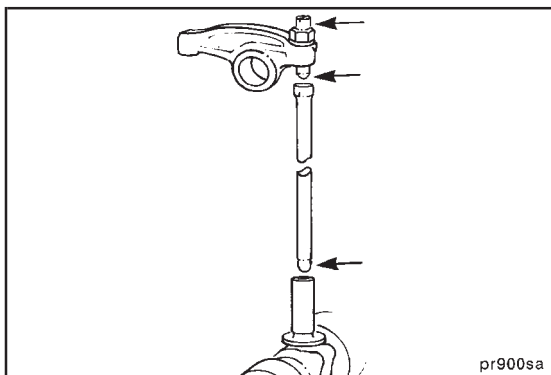

pr900sa

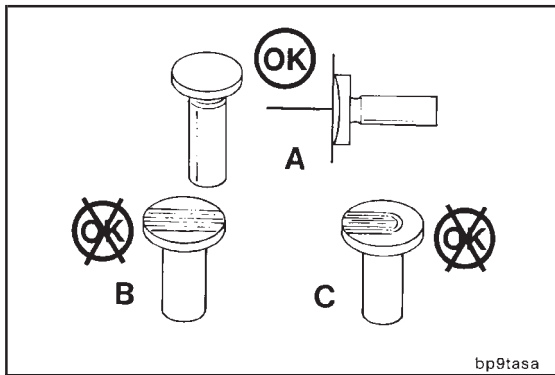

### Valve Tappets - Inspection (4-01)



Inspect the socket, stem and face for excessive wear, cracks and other damage.

#### Visual Limits

- (A) - Normal Contact
- (B) and (C) - Irregular Contact: **Do not reuse.**

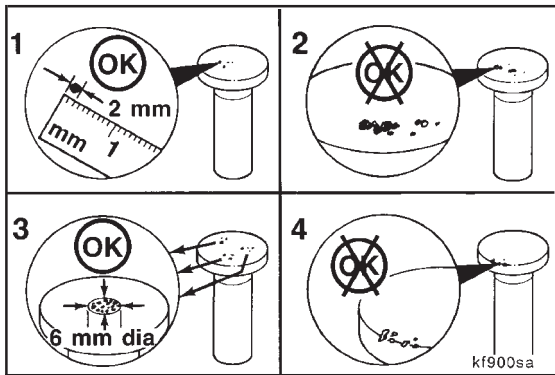

Pit marks on the tappet face are acceptable.

The following criteria defines the size of the pits allowed.

1. A single pit can not be greater than 2 mm [0.079 in].
2. Interconnection of pits is not allowed.
3. Total pits when added together should not exceed 6 mm [0.236 inch] diameter or a total of 4 percent of the tappet face.
4. No pitting is allowable on the edges of the wear face of the tappet.

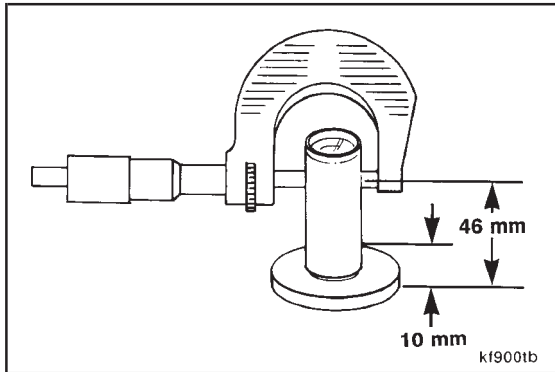

Measure the valve tappet stem.

Diameter		
mm		in
15.936	MIN	[0.627]
15.977	MAX	[0.629]

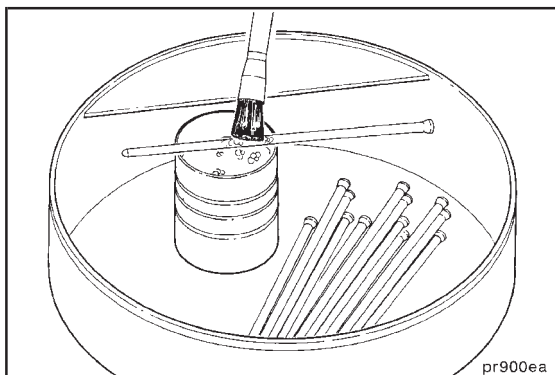

### Push Rods - Inspection (4-02)

Clean the push rods in hot soapy water.

Inspect the push rod ball and socket for signs of scoring. Check for cracks where the ball and the socket are pressed into the tube.

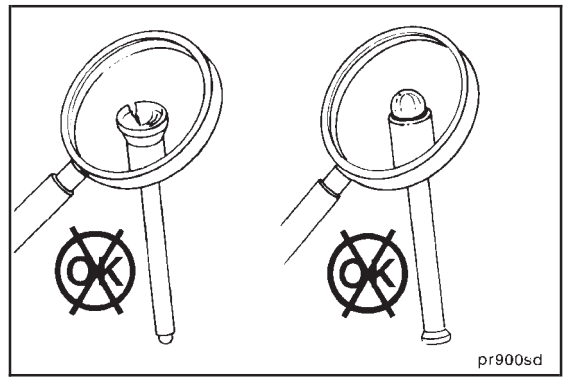

Check to see if push rods are round and straight.

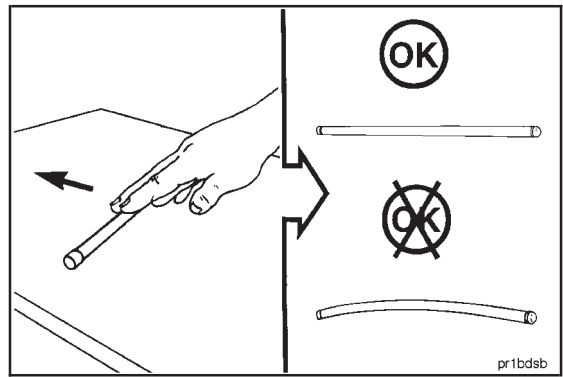

# Section 5 - Fuel System - Group 05

## Section Contents

	Page
<b>Exploded View - Fuel System</b> .....	5-3
<b>Injection Pump - General Information</b> .....	5-4
<b>Injection Pump - Identification</b> .....	5-4
<b>Injection Pump Repairs - Bosch VE</b> .....	5-15
Delivery Valve Holder/Sealing Washer - Replacement.....	5-16
Fuel Inlet Adapter/Seal - Replacement.....	5-20
Overflow Adapter/Sealing Ring - Replacement.....	5-19
Shaft Seal - Replacement.....	5-15
Shutdown Lever/Spring - Replacement.....	5-18
Shutdown Solenoid - Replacement.....	5-17
<b>Injection Pump Repairs - Lucas CAV DPA</b> .....	5-25
Automatic Timing Advance - Disassembly.....	5-33
Back Leakage Valve - Replacement/Inspection.....	5-26
Bleed Screws/Sealing Washers - Replacement.....	5-28
Control Lever - Replacement.....	5-30
Fuel Inlet Fitting/Sealing Washer - Replacement.....	5-30
Locking Screw/O-Ring - Replacement.....	5-25
Shutdown Lever/Spring - Replacement.....	5-31
Shutdown Solenoid - Replacement.....	5-27
Timing Advance - Assembly.....	5-35
Timing Advance Components - Inspection.....	5-34
Vent Fitting/Sealing Washer - Inspection/Replacement.....	5-29
<b>Injection Pump Repairs</b> .....	5-39
Fuel Inlet Banjo Connector Replacement, Bosch P7100.....	5-50
Fuel Pump Shut Off Lever Replacement, Bosch P7100.....	5-52
Fuel Shut Off Solenoid Adjustment, Bosch P7100.....	5-51
Fuel Shut Off Solenoid Bracket Replacement, Bosch P7100.....	5-52
Fuel Shut Off Solenoid Replacement, Bosch P7100.....	5-51
Injection Pump Timing - Nippondenso EP9.....	5-44
Injection Pump Timing - Stanadyne DB4.....	5-39
Pressure Relief Valve and Sealing Washer Replacement, Bosch P7100.....	5-48
Return Connection Replacement, Stanadyne DB4.....	5-40
Seal Replacement, Bosch P7100.....	5-50
Seals Replacement, Nippondenso EP9.....	5-46
Shut Down Lever or Spring Replacement, Nippondenso EP9.....	5-46
Shutdown Solenoid Inspection, Bosch P7100.....	5-54
Shutoff Solenoid Replacement, Stanadyne DB4.....	5-41
Speed Droop Adjustment Off Engine - Stanadyne DB4.....	5-43
Throttle Lever Replacement, Bosch P7100.....	5-53
<b>Injection Pump Timing - Bosch VE</b> .....	5-21
<b>KSB Electrical Solenoid Style - General Information</b> .....	5-6
Cold Start Timing Advance System (KSB) - Electrical Solenoid Style.....	5-6
VE Pump Timing Advance Principles (With Electrical Solenoid KSB Installed).....	5-8, 5-9
VE Pump Timing Advance Principles (Without KSB).....	5-7
<b>KSB Electrical Solenoid Style - Inspection</b> .....	5-12
KSB Electrical Solenoid - Inspection.....	5-12
KSB Electrical Solenoid Style Wiring Harness - Inspection.....	5-14
<b>Service Tools - Injection Pump</b> .....	5-2

### Service Tools - Injection Pump

The following special tools are recommended to perform procedures in Group 05. The use of these tools is shown in the appropriate procedure. These tools can be purchased from your local Cummins Authorized Repair Location.

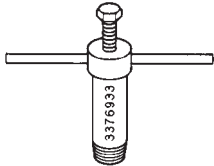
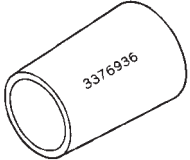
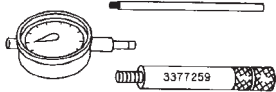
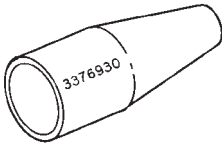
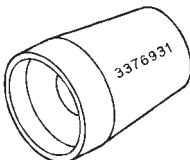
Tool No.	Tool Description	Tool Illustration
3376933	<b>Seal Puller</b> Used to pull the front drive shaft seal on Bosch VE fuel pump.	 3376933
3376936	<b>Protective Sleeve</b> Used to install the front drive shaft seal on the Bosch VE fuel pump.	 3376936
3377259	<b>Timing Tool</b> Used to check static timing on the Bosch VE fuel pump.	 3377259
3376930	<b>Protective Sleeve</b> Used to replace the o-ring on the shut down solenoid for the Lucas CAV fuel pump.	 3376930
3376931	<b>Protective Sleeve</b> Used to replace the o-ring on the pressure end cap of the timing advance mechanism on the Lucas CAV pump.	 3376931

### Exploded View - Fuel System

**Bosch VE**

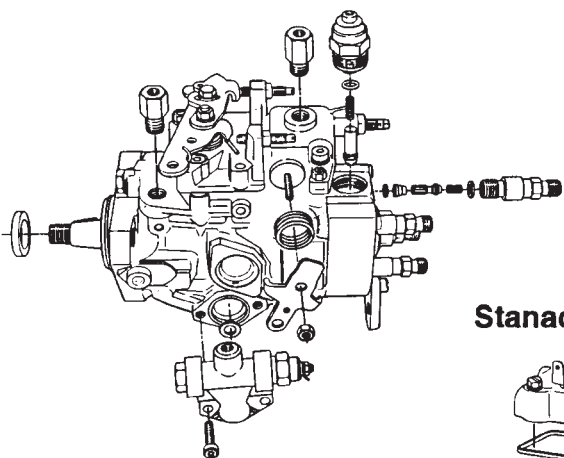

**Lucas CAV**

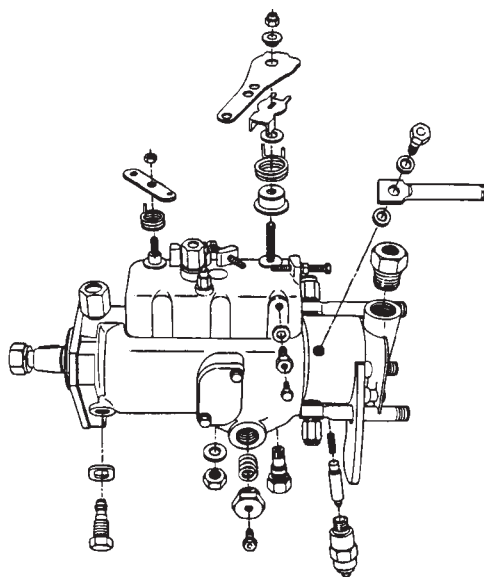

**Stanadyne DB4**

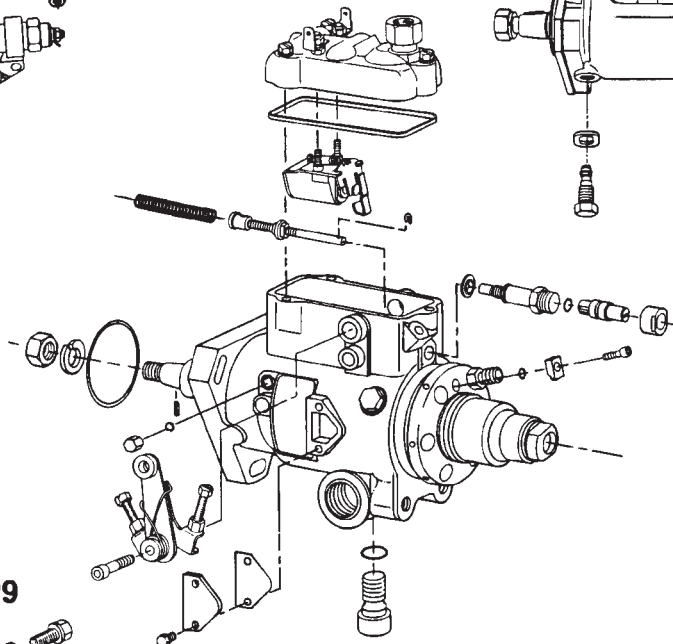

**Nippondenso EP9**

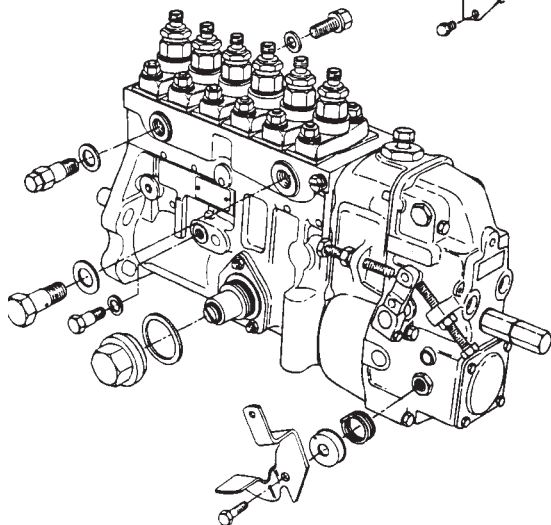

**Bosch P7100**

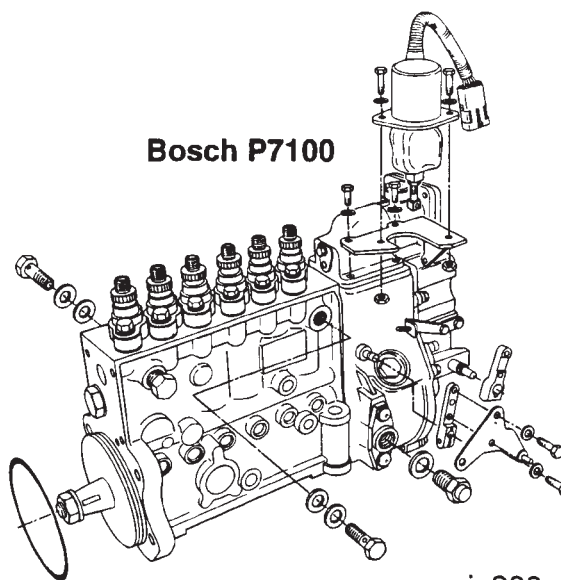

ip900gl

## Injection Pump - General Information

Rebuild and calibration of fuel injection pumps should be performed by qualified personnel using the appropriate special equipment. However, there are a number of external repairs that can be performed on the pumps without affecting the calibration. These repairs are included in this section.

During any fuel system repair, cleanliness is of utmost importance. Thoroughly clean all affected parts with solvent and then blow dry with compressed air.

## Injection Pump - Identification

Beginning in 1991, the B Series engine uses five different fuel injection pumps depending on the horsepower rating and application.

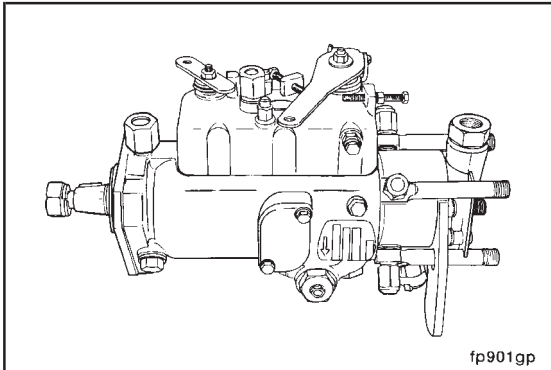

The Lucas CAV DPA distributor type injection pump.

- Gensets
- Marine
- Industrial

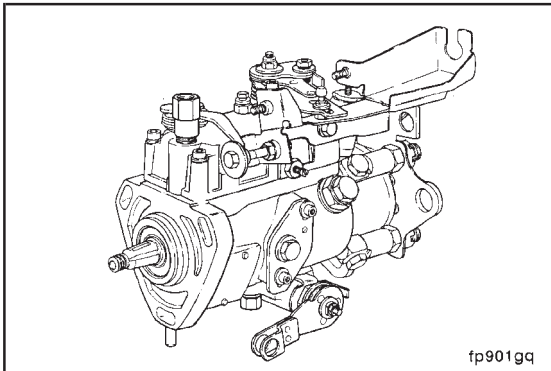

The Lucas CAV DPS distributor type injection pump.

- European automotive ratings.

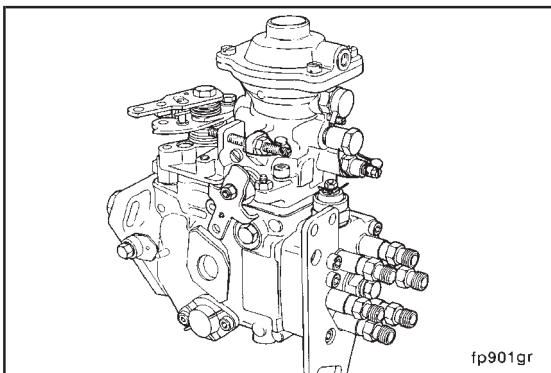

The Bosch VE distributor type injection pump.

- Industrial
- 1991 low horsepower automotive ratings.



The Stanadyne DB4 distributor type fuel injection pump.

- Gensets

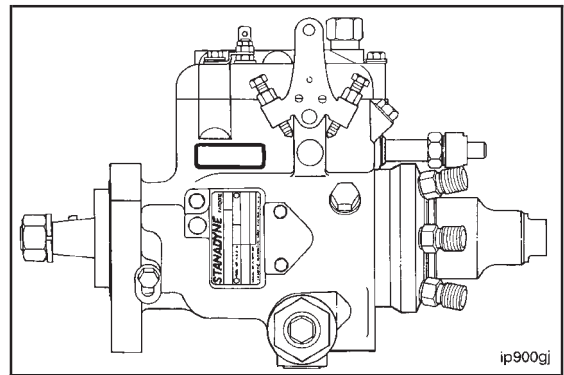

The Bosch P7100 in-line fuel injection pump.

- 1991 high horsepower automotive ratings.
- All 1994 automotive ratings.

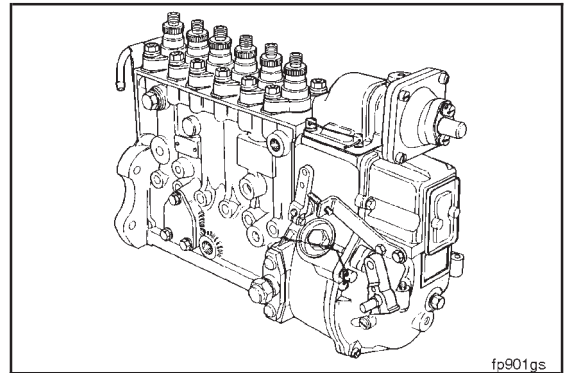

The Nippondenso EP-9 in-line fuel injection pump with the RSV governor.

- 250, 300 and 315 horsepower marine ratings.
- High horsepower/industrial ratings.

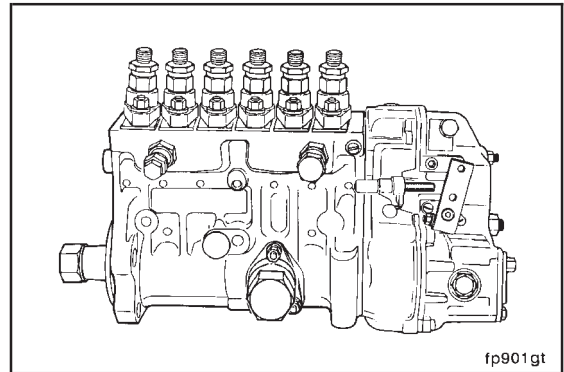

## KSB Electrical Solenoid Style - General Information

### Cold Start Timing Advance System (KSB) - Electrical Solenoid Style

The electrical solenoid style KSB is used on 1991 model and newer B series automotive engine ratings using the Bosch VE fuel pump.

**NOTE: The wax motor style KSB is used on pre-1991 B series automotive engine ratings using the Bosch VE fuel pump. Refer to the B Series Shop Manual, Bulletin No. 3810206, for information.**

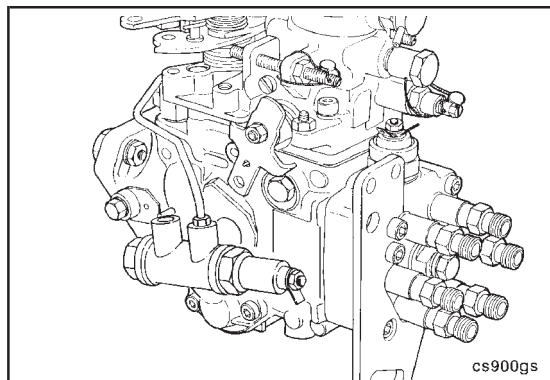

Wax Motor Style KSB (Pre-1991)

Note: Temperature switch is located in coolant jacket.

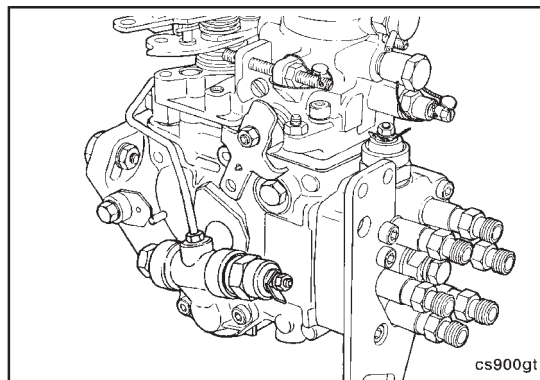

Electrical Solenoid Style KSB (1991)

Note: Temperature switch is located in intake manifold.

**VE Pump Timing Advance Principles (Without KSB)**

Pump housing pressure acts on an internal timing piston (1), Figure 1, to partially advance the injection timing at idle, and fully advance the timing when the engine RPM reaches approximately 60% of rated speed. As pump pressure increases, timing advances.

The pump housing pressure is controlled by the pressure regulator valve (2) (a spring loaded slider valve). The valve is shown in the open and closed position.

When housing pressure is low, the spring (3) forces the slider (4) into the closed position. This permits the housing pressure to increase by preventing fuel drainage through the return passage (5).

As housing pressure increases it forces the slider (4) to compress the spring (3). This action opens the return passage (5) and relieves the housing pressure.

A relief port (6) located on the spring side of the slider valve, allows fuel that seeps past the slider (4) to drain. Relief port drainage is necessary to avoid a hydraulic lock of the slider valve, which would render the pressure regulator valve (2) inoperable. In fact, it is this characteristic that is used in conjunction with KSB to advance the timing during cold engine operation.

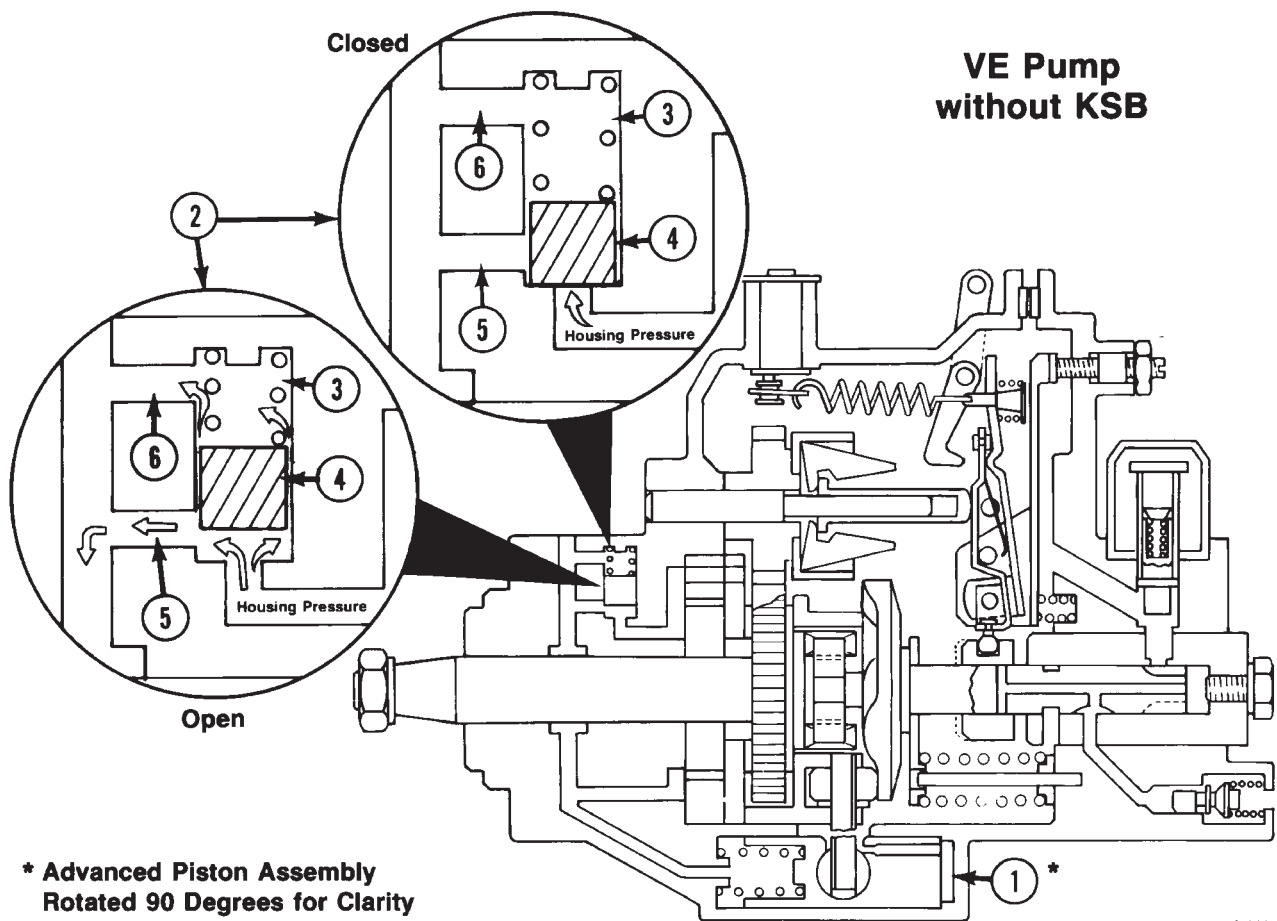

**Figure 1, VE pump timing, regulated by opening and closing the pressure regulator valve**

## VE Pump Timing Advance Principles (With Electrical Solenoid KSB Installed)

The KSB introduces a new fuel line (1), Figure 2, which routes fuel from the relief port (2) of the pressure regulator valve (3) to the plunger end (6), Figure 3, of the electrical solenoid, bypassing the normal return passage (6), Figure 1.

With the key switch on, current flows from the key switch line to the 90°F normally closed intake manifold switch to the 12V electrical KSB solenoid (see Figure 2). When the engine starts the pressure regulating valve (3) attempts to regulate fuel pressure as before (without KSB) but the fuel from the relief port (2) now meets a 'dead end' at the plunger of the KSB solenoid (6), Figure 4. With the key switch on, the plunger moves outward and closes off the flow of the fuel (8), Figure 4. This action hydraulically locks (closes) the pressure regulator slider valve (4), Figure 1.

Housing pressure (5), Figure 2, is not regulated because the pressure regulator valve (3) is inoperable and so the pressure continues to increase. This action fully advances the timing. The timing remains fully advanced until the plunger (6), Figure 4, is opened and fuel is allowed to drain through fuel drain flow path (8), Figure 4.

When the intake manifold temperature reaches 90°F, the 90°F normally closed IMT switch opens and voltage is no longer applied to the KSB solenoid (10). With no voltage applied to the KSB solenoid (13), fuel pressure overcomes the plunger force and pushes the plunger back to open the fuel drain flow path (8).

Fuel from the relief port of the pressure regulating valve now has a drain path (8), Figure 4, past the KSB solenoid plunger (6), Figure 4 (which is now open) to the drain. The pressure regulator valve resumes normal operation and the injection timing is regulated accordingly.

The electrical solenoid style KSB is also equipped with a pressure relief valve (7), Figure 3. If the engine is taken to high idle with the KSB solenoid plunger in the closed position (6), Figure 3, housing pressure can increase enough to rupture the fuel pump housing. The pressure relief valve (7), Figure 3, will pop off its seat before this occurs, however. At a pressure of 4 bar (60 psi), the pressure relief valve (7), Figure 3, opens and allows fuel to drain through an alternate flow path (9), Figure 3.

**VE Pump Timing Advance Principles (With Electrical Solenoid KSB Installed)**

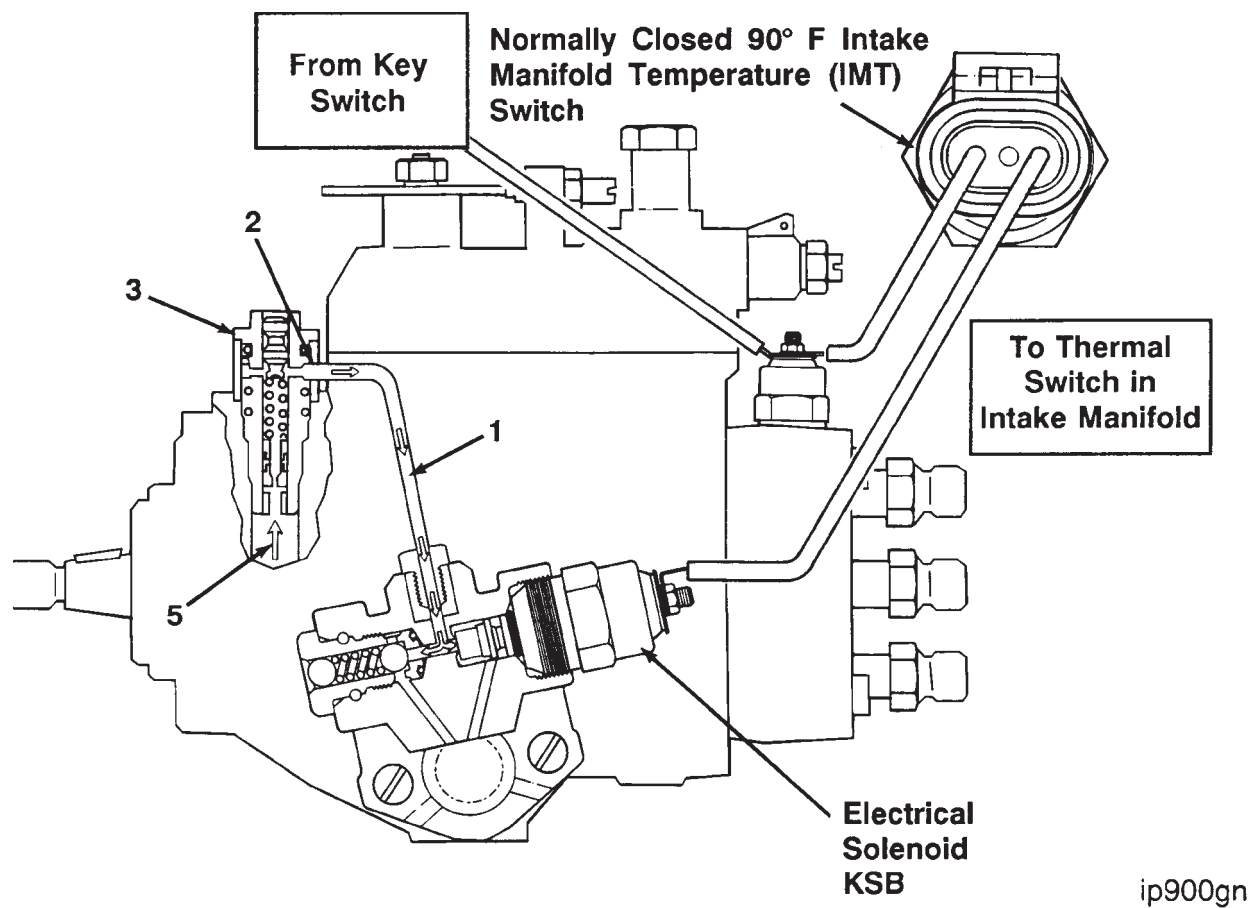

**Figure 3: Cold Engine Operation (Less Than 90°F IMT), Advanced Timing**

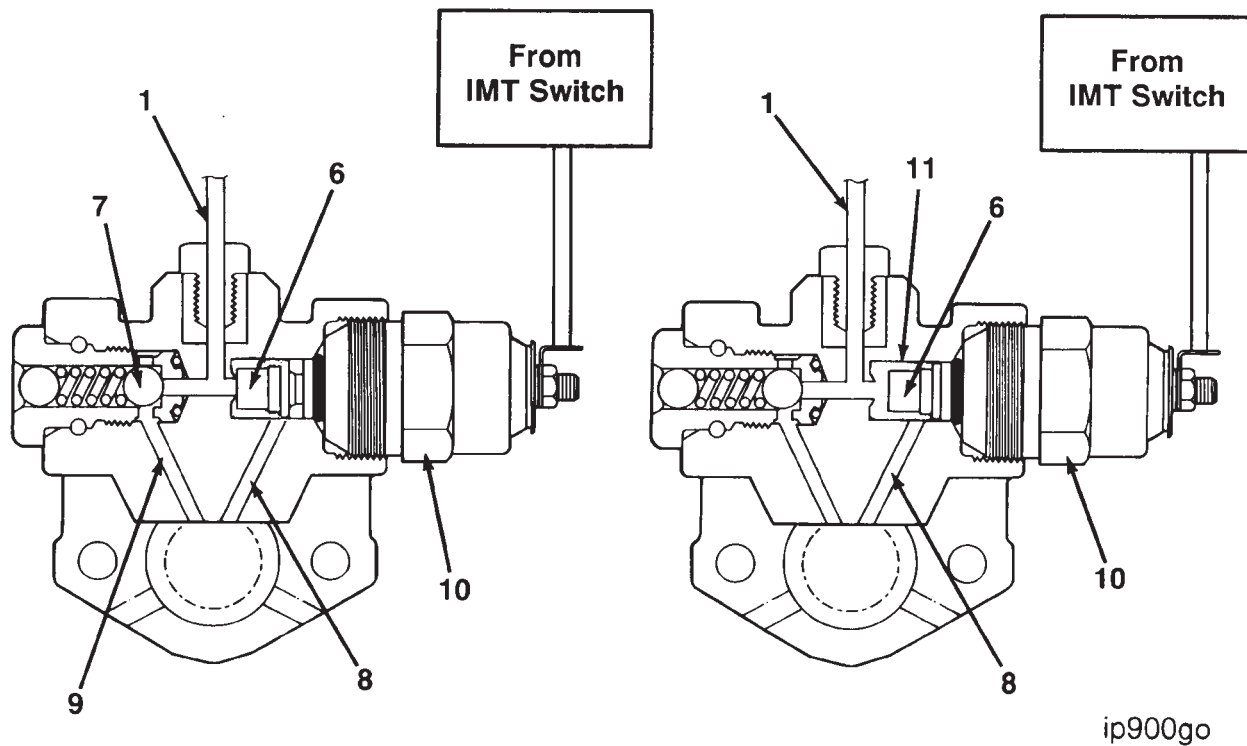
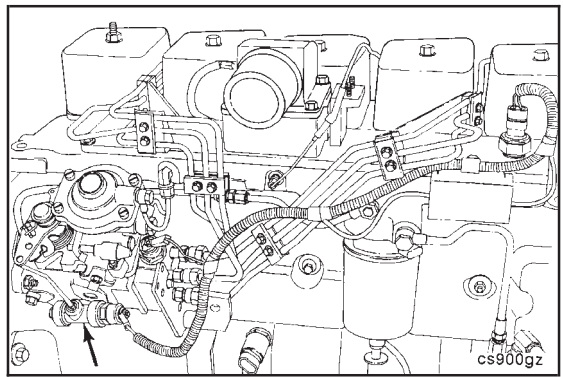

Figure 4: Warm Engine Operation (More Than 90°F IMT), Retarded Timing

Two types of electrical solenoid style KSB valves are available.

The first type is the pump mounted KSB, as shown.



The second type is the remote mounted KSB, as shown.

The remote mounted KSB is used on B series automotive engines which have an air compressor.

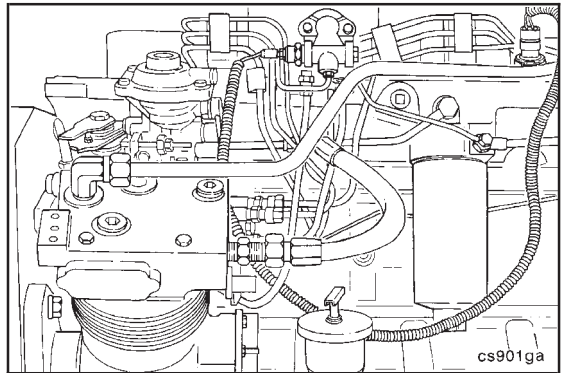

**Caution:** Most pumps will have a shim between the KSB and the timing piston. This shim must be reassembled between the cover plate and the timing piston. If this shim sticks to the KSB and is installed with the remote mounting hardware, it will block the regulating valve drain path and damage the pump. This damage is usually evidenced by a fuel leak.

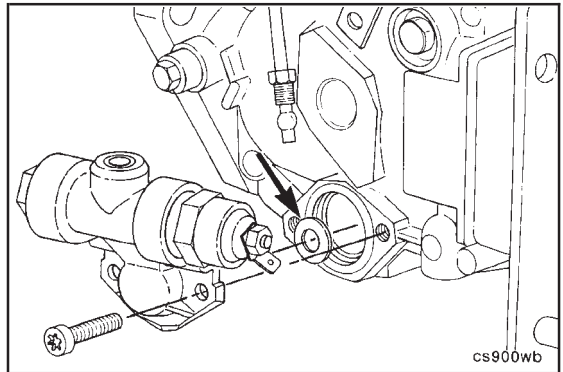

Both the 4 and 6 cylinder have the temperature switch mounted in the intake manifold as shown.

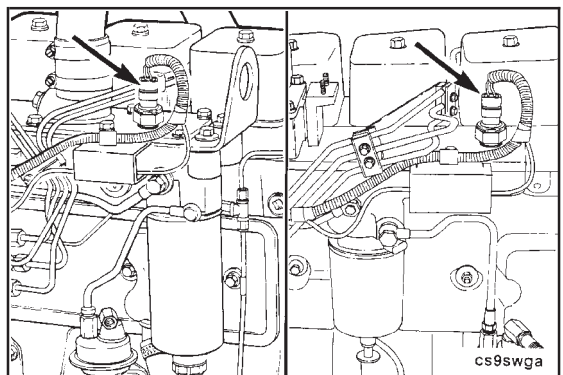

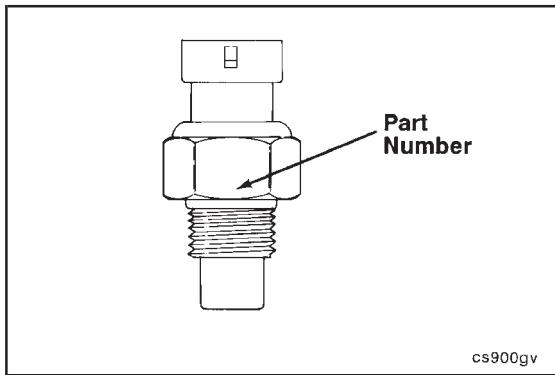

### KSB Electrical Solenoid Style - Inspection

Temperature switches are not interchangeable. White smoke will be present if the wrong temperature switch is used.

Check the part number to be sure the correct temperature switch is used.

- 1) The electrical solenoid style KSB (used on 91 models and newer) uses a 90°F [32°C] normally closed intake manifold temperature switch, Part No. 3920598.
- 2) The wax motor KSB (used on pre-91 engines) uses a 160°F [71°C] normally open coolant temperature switch, Part No. 3921642.

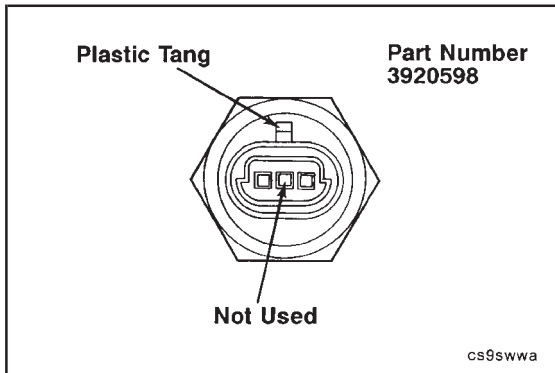

Although the electrical solenoid style KSB uses an intake manifold temperature switch, the operation of the switch can be checked by connecting a volt/ohm meter to the switch, placing the switch in ice water, and then heating the water to 90°F [32°C].

Connect the VOM to the two outside pins of the temperature switch.

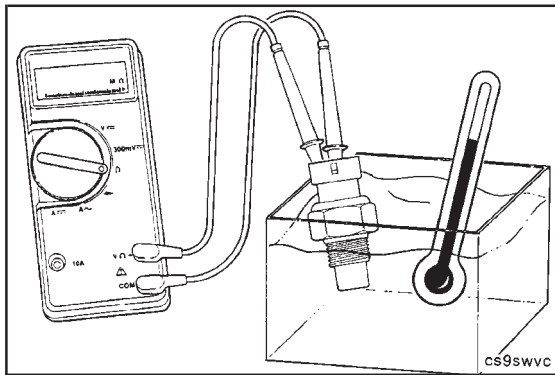

Check the water temperature with a thermometer.

The VOM should indicate a closed circuit below 90°F [32°C] and an open circuit above 90°F [32°C].

Replace the switch if necessary.

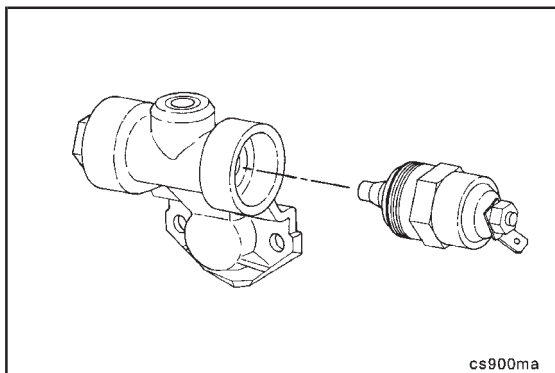

### KSB Electrical Solenoid - Inspection

24 mm

Remove the KSB electrical solenoid from the KSB housing.





Apply 12 volts to the electrical terminal and ground the hexagonal portion of the element. The magnetic coil of the solenoid must push the plunger outward.

If the plunger does not push outward when voltage is applied, the solenoid is defective and must be replaced.

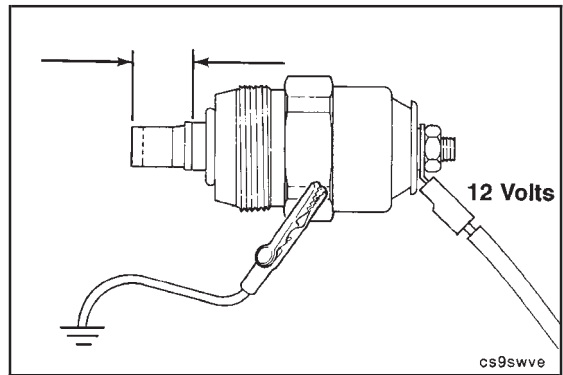

**24 mm**

Install the original solenoid or a replacement into the KSB housing.

**Torque Value:** 22 N•m [16 ft-lb]

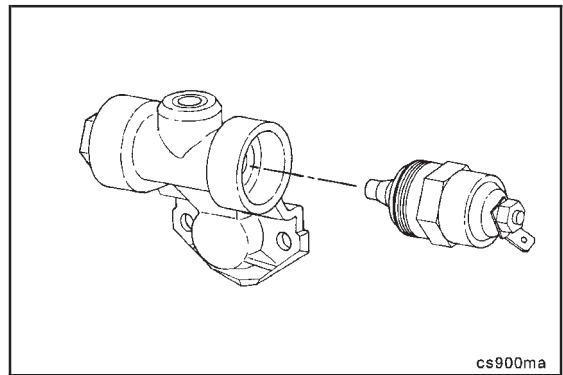

**17 mm**

Remove the pressure relief valve.

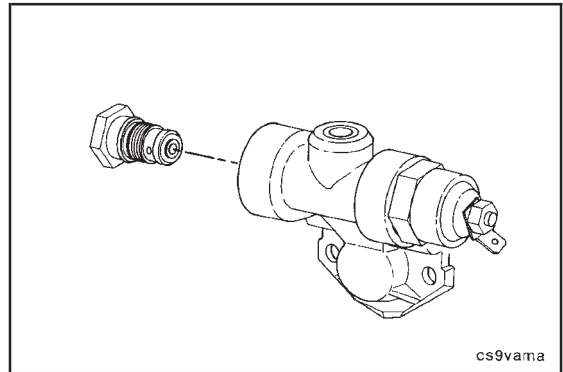

Thoroughly flush the pressure relief valve with cleaning solution.

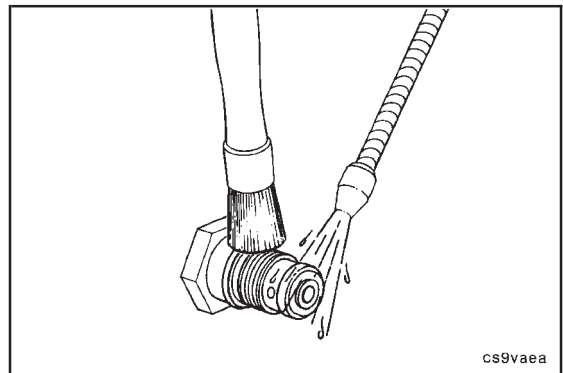

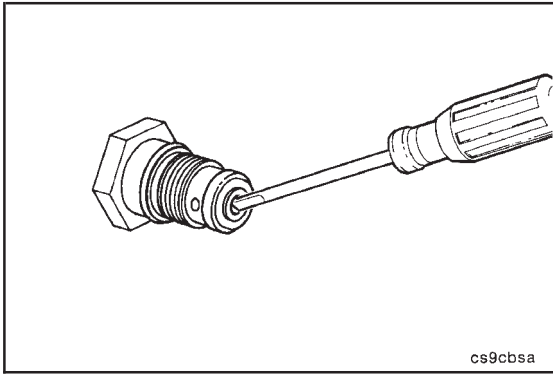

Use a very small screwdriver to be sure the check ball is not sticking.

**NOTE:** A sticking or malfunctioning pressure relief valve will result in either white smoke or a ruptured fuel pump housing.

Replace the pressure relief valve assembly if necessary.

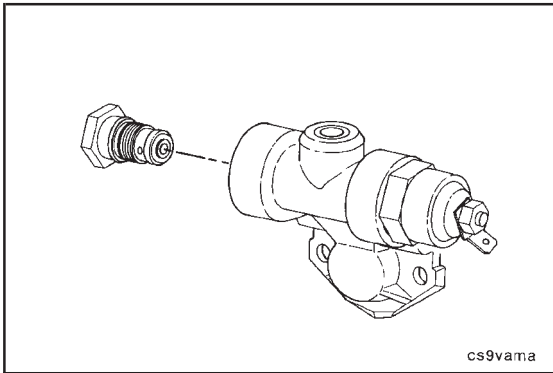

17 mm

Install the original pressure relief valve or a replacement into the KSB housing.



**Torque Value:** 13 N•m [10 ft-lb]

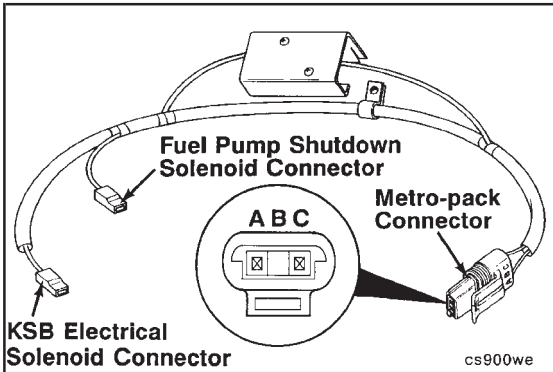

**KSB Electrical Solenoid Style Wiring Harness - Inspection**

The wiring harness used on the electric solenoid style KSB can be inspected using a volt-ohm meter.

**NOTE:** Pin 'B' of the metro-pack connector is blank on the electric solenoid style KSB wiring harness.

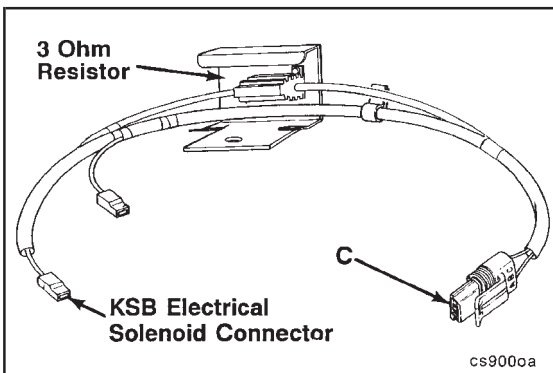

The electric solenoid style KSB wiring harness contains a 3 ohm resistor in the wire leading from Port 'C' of the metro-pack connector to the KSB electrical solenoid connector.

The 3 ohm resistor is mounted to a bracket which is used as a 'heat sink' to absorb heat that is generated by the resistor.

CPI 1351 incorporates the resistor in the wiring harness.

CPL 1579 does not require a resistor.

Use a volt/ohm meter to perform a continuity check between Port 'C' of the metro-pack connector and the KSB electrical solenoid connector.



Repair the wire if there is an open circuit.

(Spec = Less than 10 ohms).

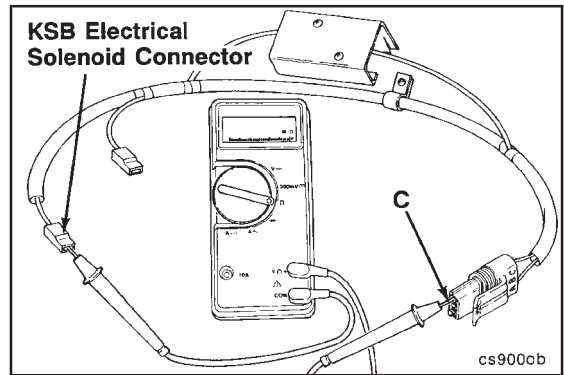

Use a volt/ohm meter to perform a continuity check between Port 'A' of the metro-pack connector and the fuel pump shut down solenoid connector.



Repair the wire if there is an open circuit.

(Spec = Less than 10 ohms).

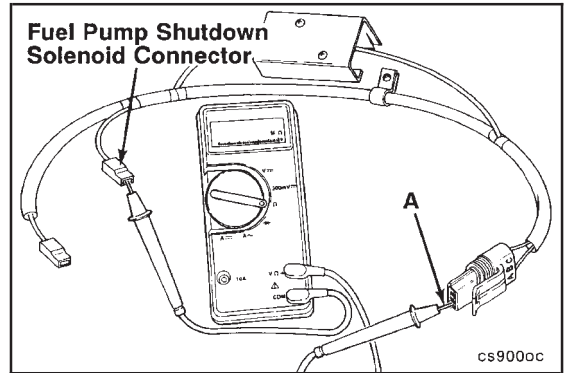

## Injection Pump Repairs - Bosch VE (5-01)

### Shaft Seal - Replacement (5-02)

Seal Puller Part No. 3376933

Remove the seal.

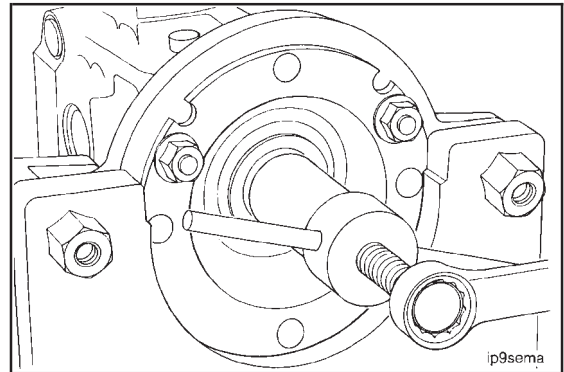

Inspect the seal seating area for nicks and burrs. Minor clean-up (deburring) is allowed providing the area is thoroughly flushed with solvent and dried with compressed air.

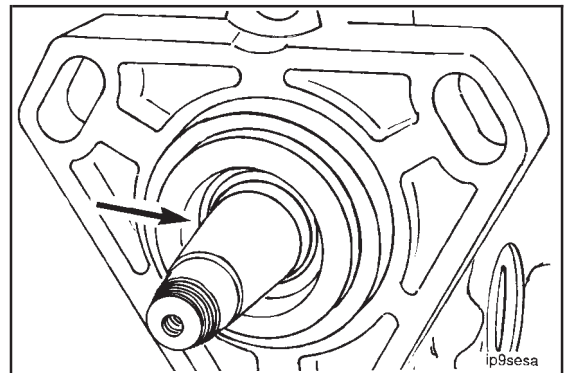

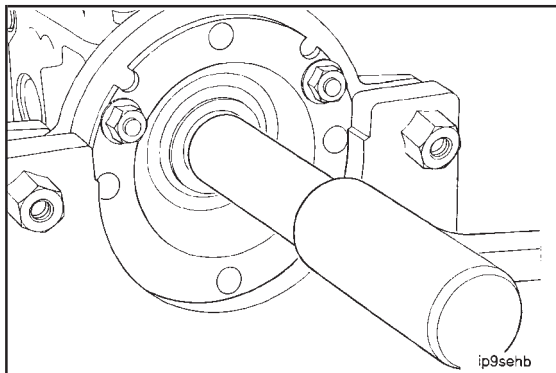

**Protective Sleeve Part No. 3376936**

Install the new seal onto the shaft using a protective sleeve.



Drive the seal in until it bottoms in the seal bore.

Service Tip: A deep well socket that contacts the outside diameter (metal surface) of the seal will work adequately to drive in the new seal.

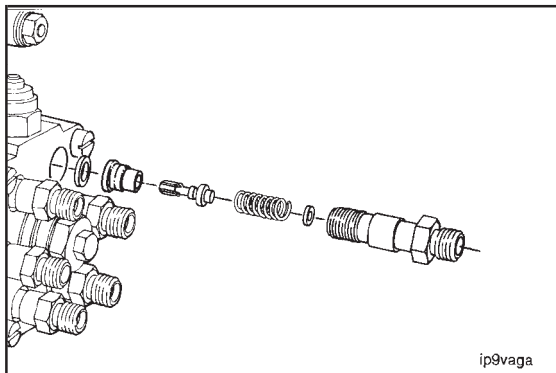

**Delivery Valve Holder/Sealing Washer - Replacement (5-03)**

14 mm

Remove the delivery valve holder, shim (if used), delivery valve and sealing washer.

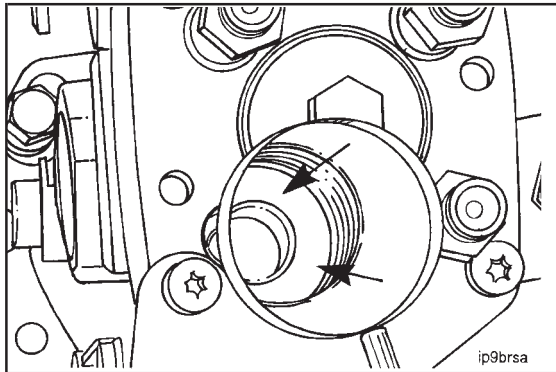

Inspect the sealing surfaces on the high pressure head, the delivery valve and the delivery holder.

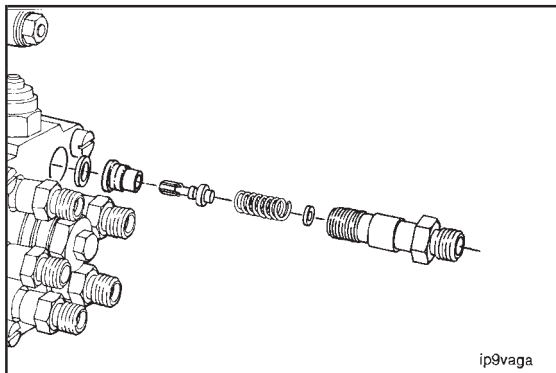

Install the delivery valve holder assembly and new sealing washer as illustrated.

14 mm

Tighten the holder.

**Torque Value:** 31 N•m [23 ft-lb]

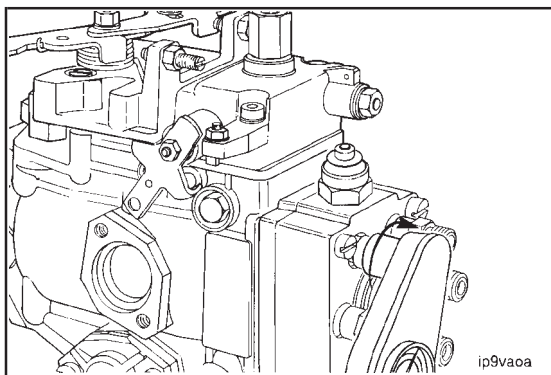

**Shutdown Solenoid - Replacement (5-04)**

24 mm

Remove the solenoid and o-ring.

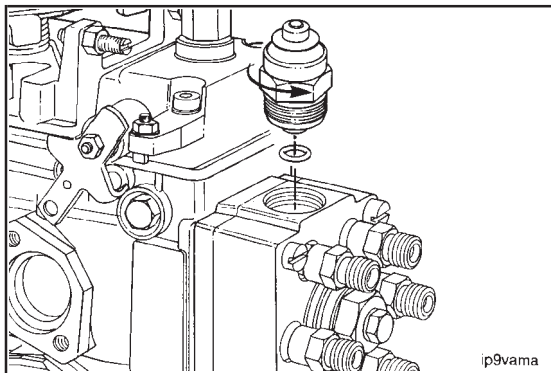

Remove the plunger and spring. Clean the plunger seat in the injection pump.

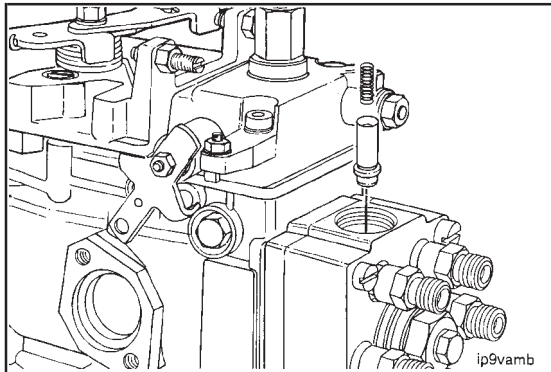

Place a new o-ring on the replacement fuel solenoid.

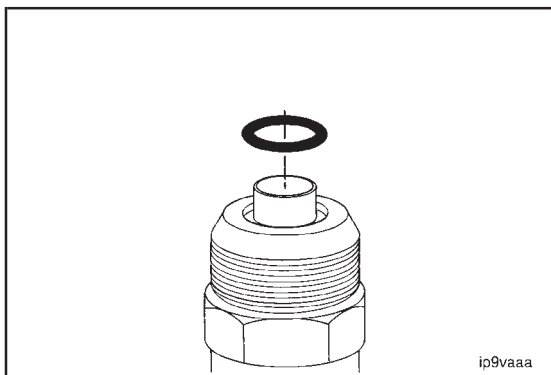

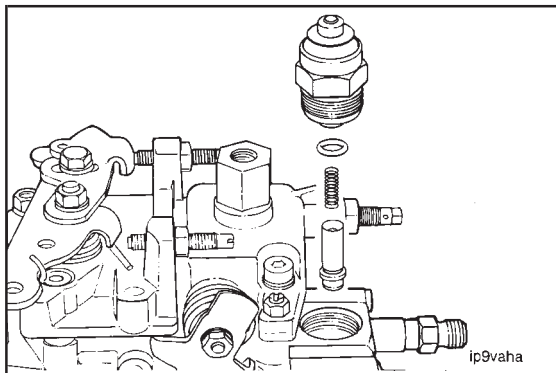

24 mm

Install the new fuel solenoid, plunger and spring into the distributor head.



Tighten the solenoid securely.



**Torque Value:** 43 N•m [32 ft-lb]

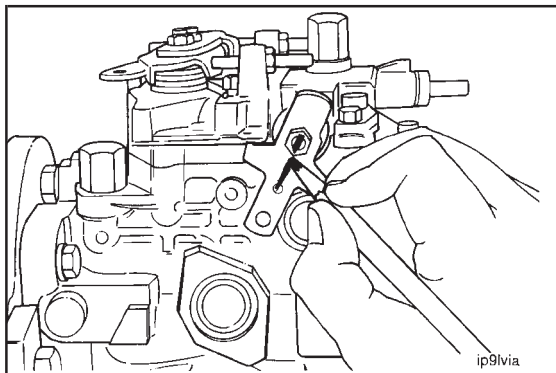

**Shutdown Lever/Spring - Replacement (5-05)**

**Caution:** Mark the shutdown lever so it can be installed in the same position. Failure to do so will result in incorrect installation.

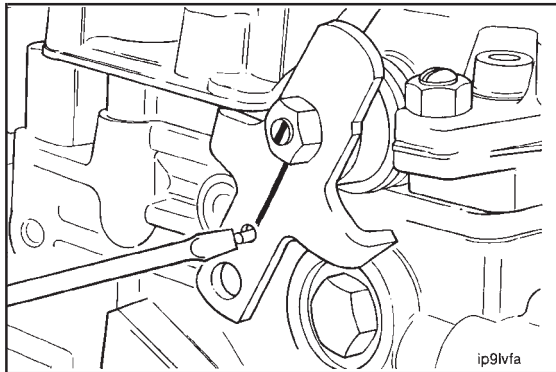

Disconnect the return spring.

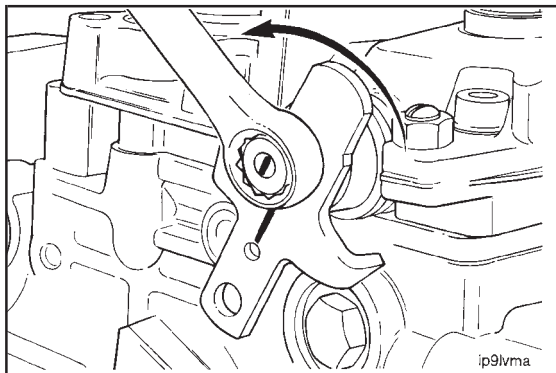

10 mm

Remove the lever and spring.



Use the removed lever as a pattern and mark the replacement lever so it can be installed in the same position as the removed lever.

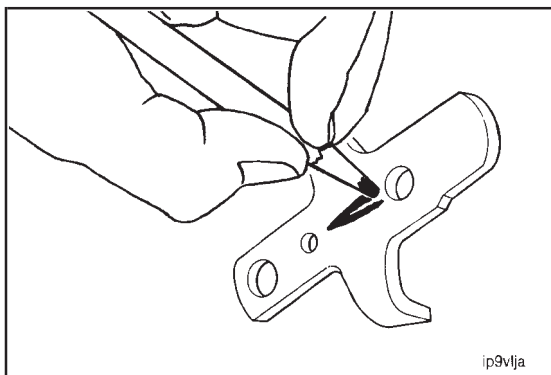

10 mm

Align the marks and install the spring and lever.

Install and tighten the lock washer and nut.

Torque Value: 5-10 N•m [4-7.5 ft-lb]

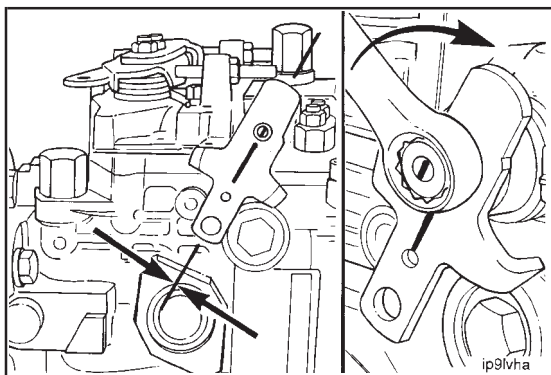

**Overflow Adapter/Sealing Ring - Replacement (5-06)**

19 mm

Remove the overflow adapter.

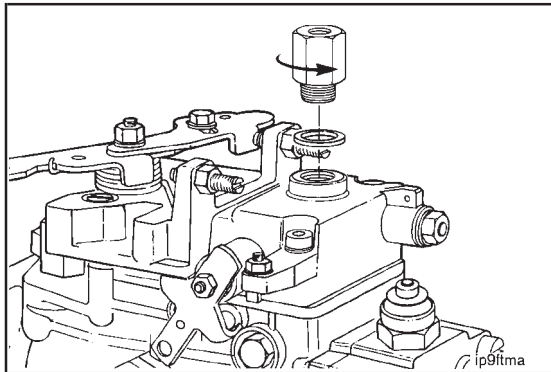

Inspect the sealing surfaces on the adapter and the pump.  
Be sure orifice in the adapter is open.

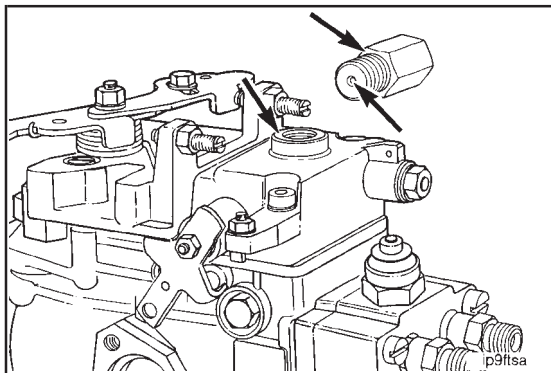

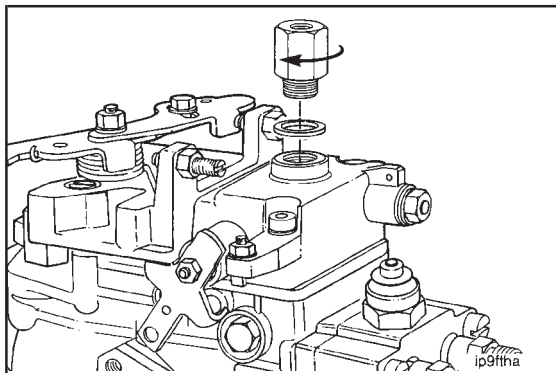

19 mm

Install a new sealing washer and tighten the adapter.



**Torque Value:** 23 N•m [17 ft-lb]

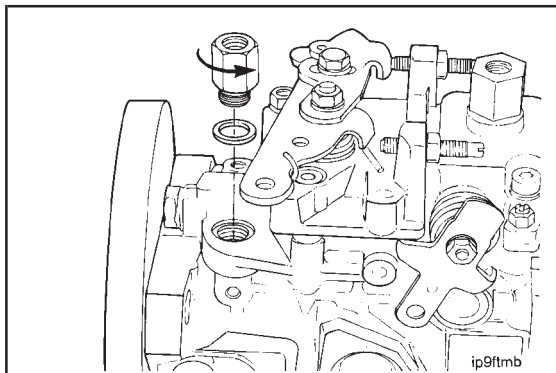

19 mm

Remove the adapter and sealing washer.



**Fuel Inlet Adapter/Seal - Replacement (5-07)**

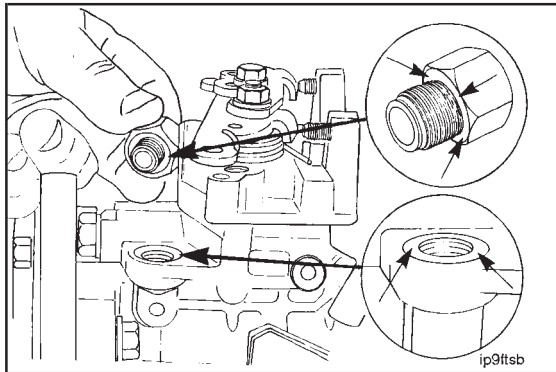

Inspect the sealing surfaces.

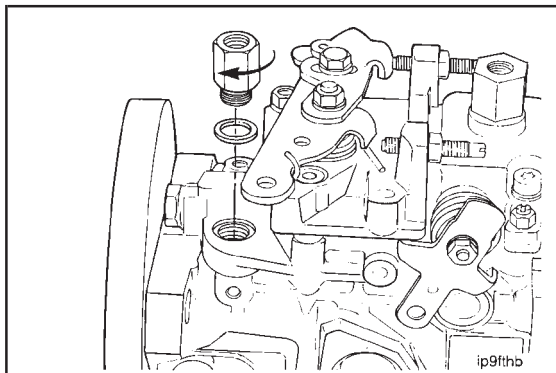

19 mm

Install a new sealing washer and tighten the adapter.



**Torque Value:** 23 N•m [17 ft-lb]





## Injection Pump Timing - Bosch VE (5-08)

Secure the pump in a vise.

**Caution:** Do not over tighten the vise or position the pump in the vise in such a way as to damage the pump housing.

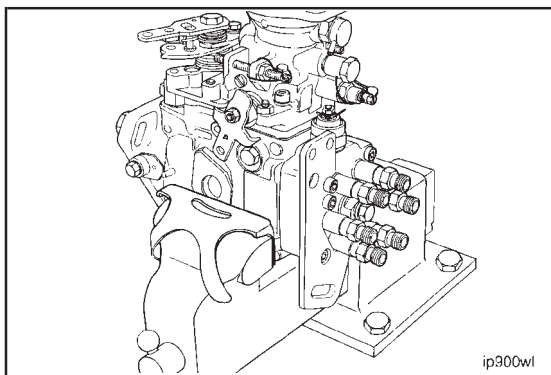

### 12 mm

Remove the access plug from the rotary head central screw assembly.

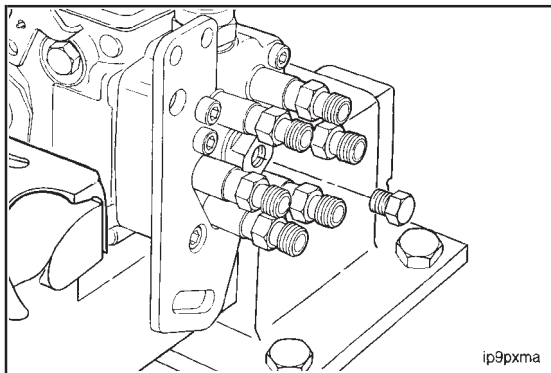

### Timing Tool Part No. 3377259

Thread the timing tool extension into the access plug hole. Finger tighten.

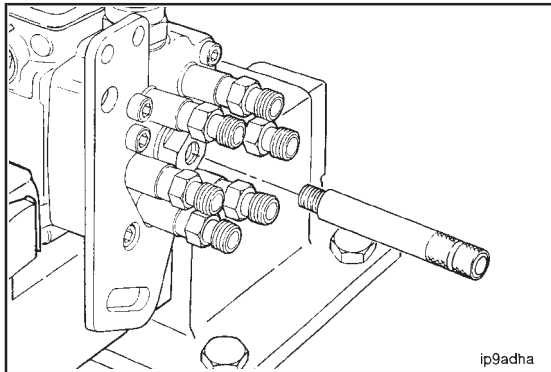

Thread the dial indicator tip extension into the dial indicator. Finger tighten.

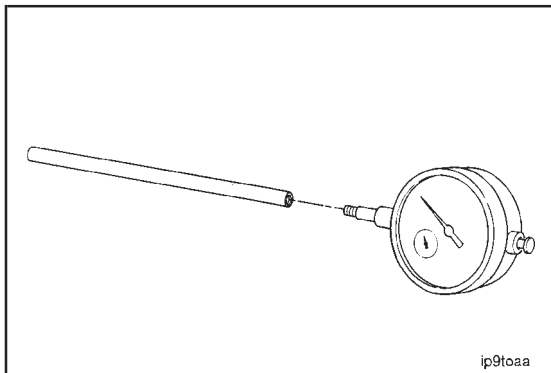

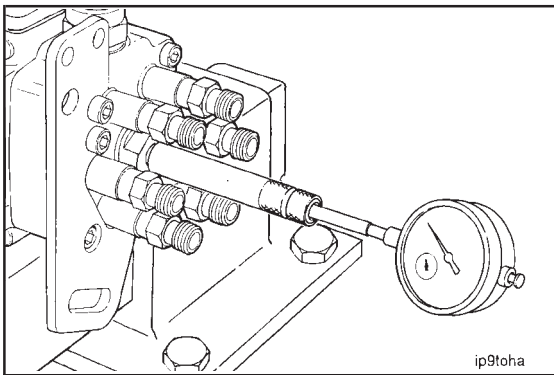

Install the dial indicator into the timing tool extension.

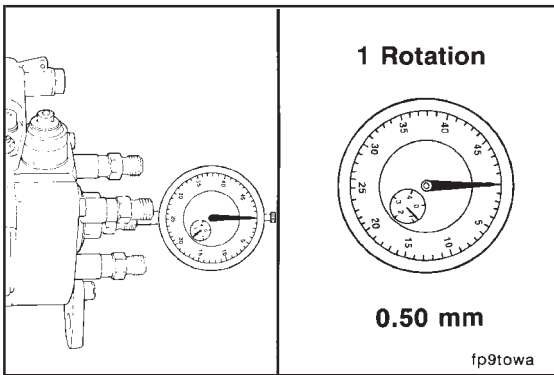

Set the indicator to allow at least 3.0 mm travel. Tighten the locking sleeve finger tight.

**NOTE:** The indicator travel should be set with the pump unlocked.

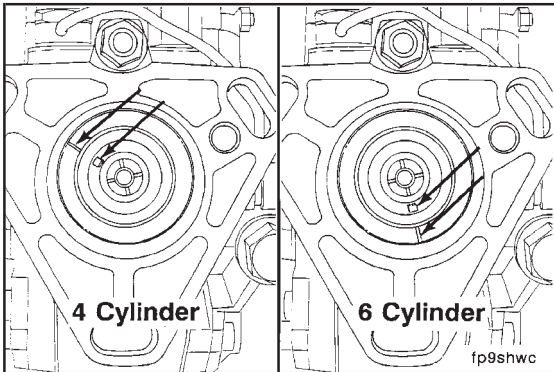

At the point of injection the key way of the shaft will align with the delivery valve receiving the injection, and the illustrated hash mark on the seal housing.

**NOTE:** The illustrated mark is for **reference only** and should not be used for setting the pump timing.

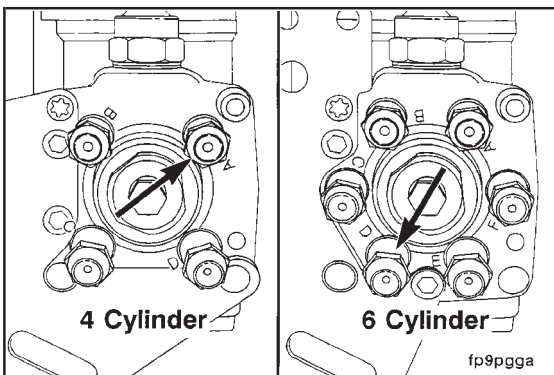

The number one cylinder delivery valve is marked as illustrated.

4 cylinder = A  
6 cylinder = D

Firing Order  
 4 Cylinder      6 Cylinder  
 A = 1            D = 1  
 B = 3            E = 5  
 C = 4            F = 3  
 D = 2            A = 6  
                       B = 2  
                       C = 4

Install the drive gear retaining nut on the pump drive shaft.

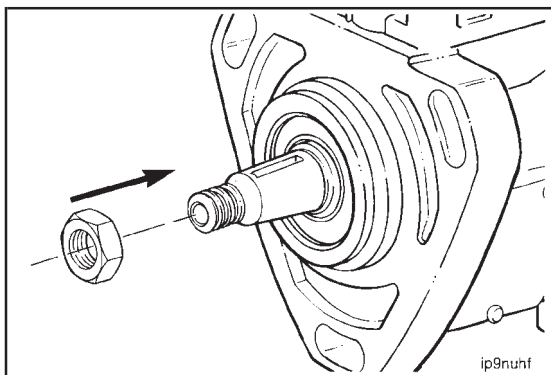

Make sure the pump is unlocked.

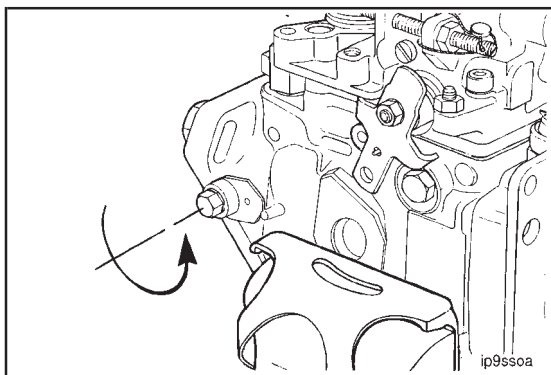

Rotate the drive shaft clockwise. As the pump is rotated the gage will rotate in a clockwise direction.

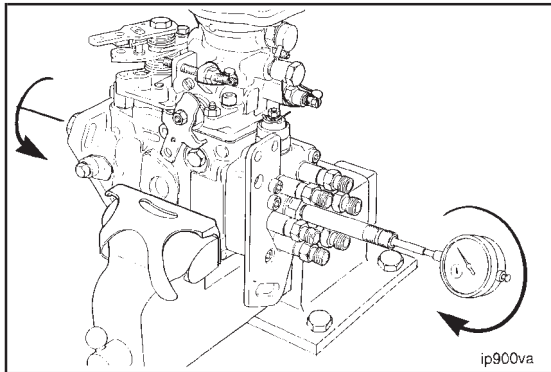

As injection is completed to the respective ports the pump will snap. At this point the gage will reverse direction to counterclockwise. Zero the gage at the point the needle stops and reverses to clockwise again.

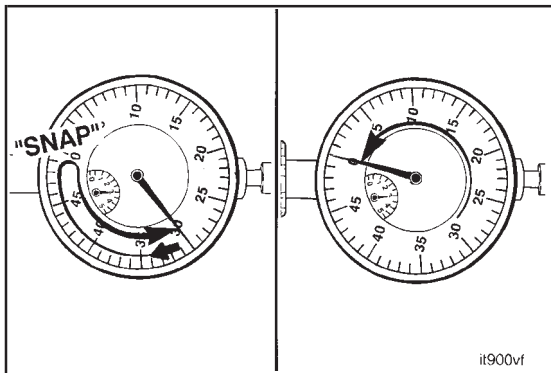

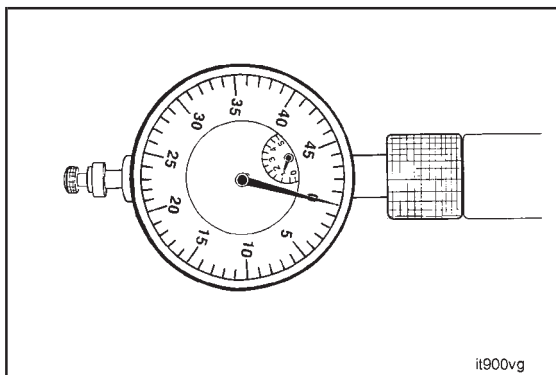

Continue to rotate the pump clockwise until the keyway is preparing to align with the number one delivery valve. Verify the gage is properly zeroed.

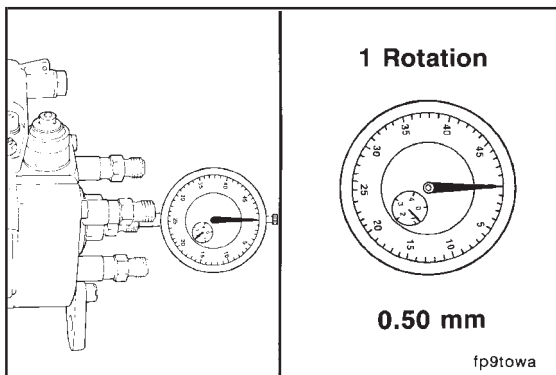

Continue rotating the pump clockwise while watching the gauge. Count the revolutions. Each revolution equals 0.50 mm.

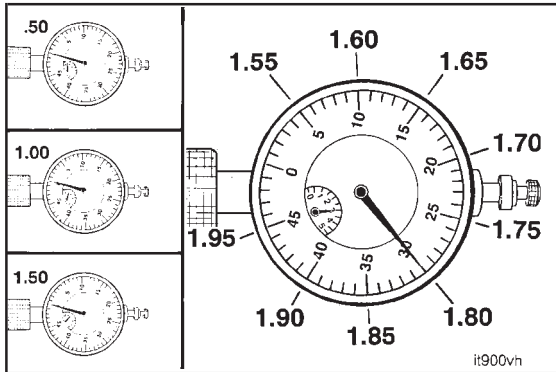

Three revolutions equal 1.50 mm. This illustration gives an example of the indicator readings for the various plunger lift values.

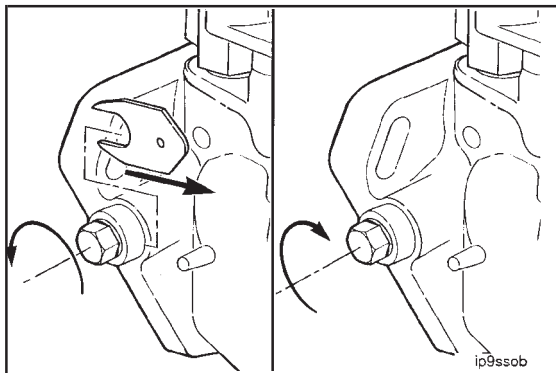

10 mm

Lock the pump at the desired plunger lift.

Remove the nut from the drive shaft by striking the wrench with a sharp blow in a counterclockwise direction.

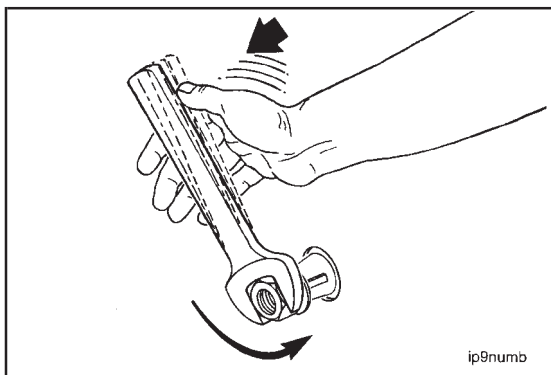

ip9numb

**12 mm**

Remove the dial indicator assembly and install the access plug. Tighten to 8-10 N•m [6-7.5 ft. lb].

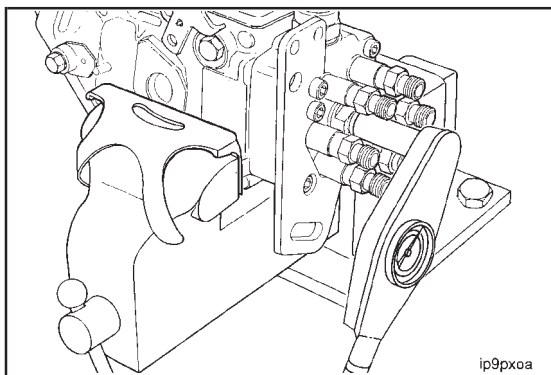

ip9pxoa

**Injection Pump Repairs - Lucas CAV  
DPA (5-09)**

**Locking Screw/O-Ring - Replacement (5-10)**

Precisely mark the shaft position **before** removing the locking screw.

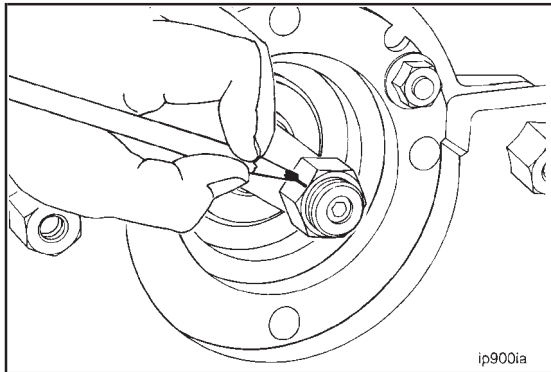

ip900ia

**15 mm**

Remove the locking screw and washer.

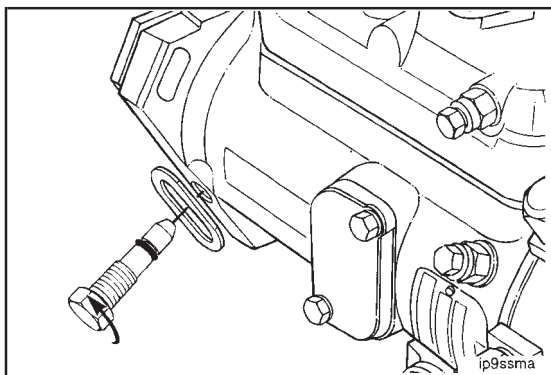

ip9ssma

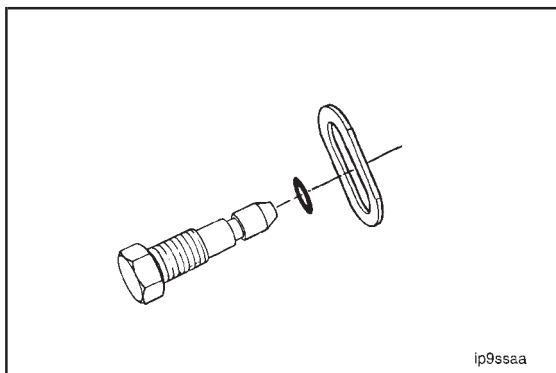

Install a new o-ring. Replace special washer, if required.

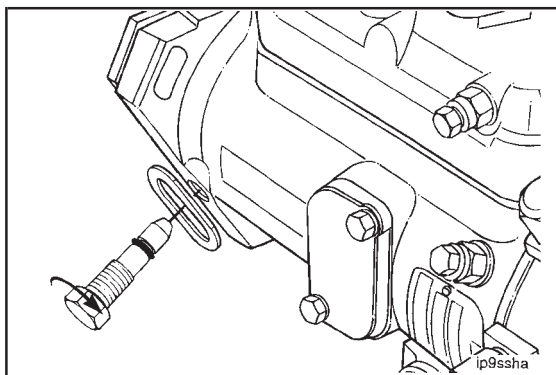

15 mm

Verify the shaft is still aligned and install the locking screw assembly.



Torque Value: 30 N•m [22 ft-lb]

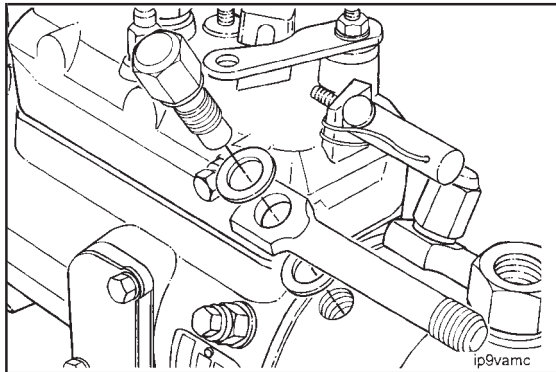

### Back Leakage Valve - Replacement/ Inspection (5-11)

16 mm

Remove the back leakage valve and sealing washer.

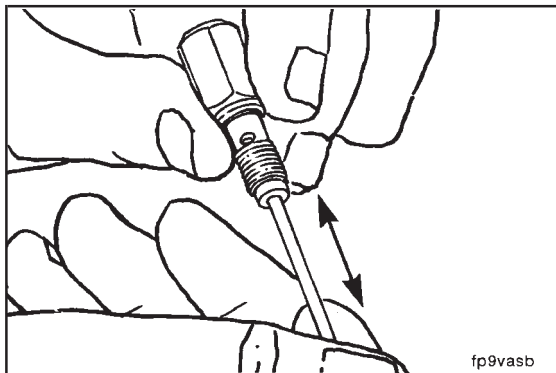

Inspect the valve to be sure it is not stuck.

Inspect the sealing surfaces for possible leak paths.

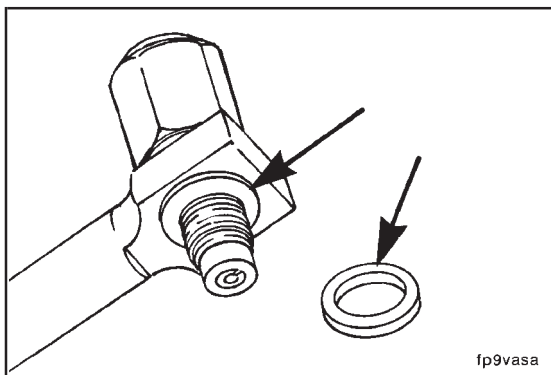

**16 mm**

Assemble the back leakage valve and new washers.

**Torque Value:** 31 N•m [23 ft-lb]

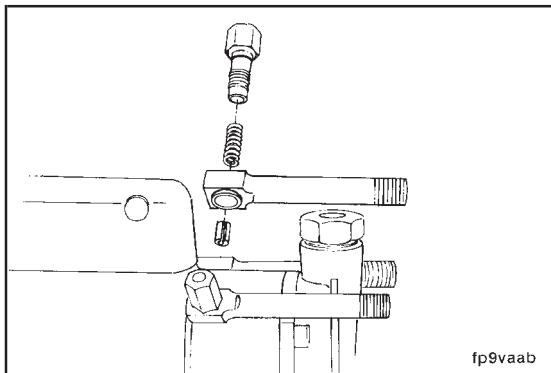

**Shutdown Solenoid - Replacement (5-12)**

**24 mm**

Remove the solenoid, o-ring, spring and plunger.

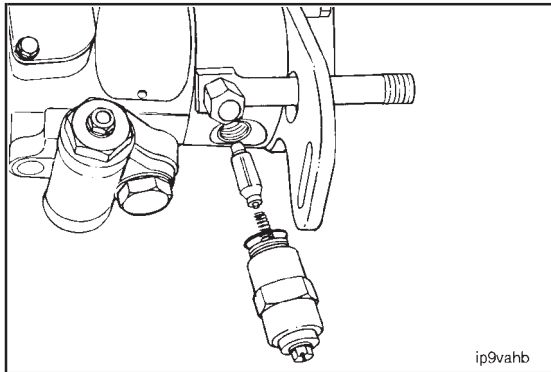

**Part No. 3376930 14.7 mm Protective Sleeve**

Replace the o-ring. Use the protective sleeve to prevent cutting the o-ring.

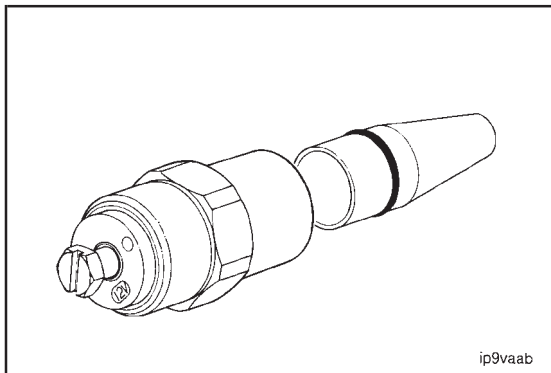

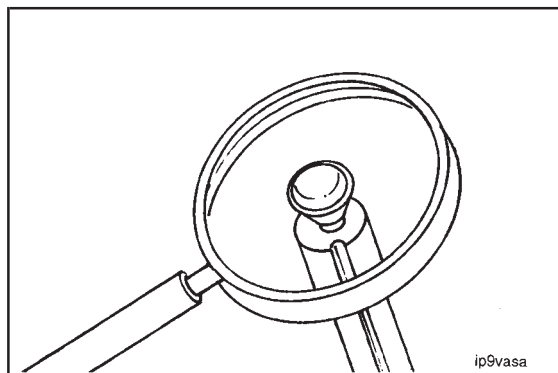

Inspect the plunger tip. If the tip is damaged or deformed, replace the solenoid assembly.

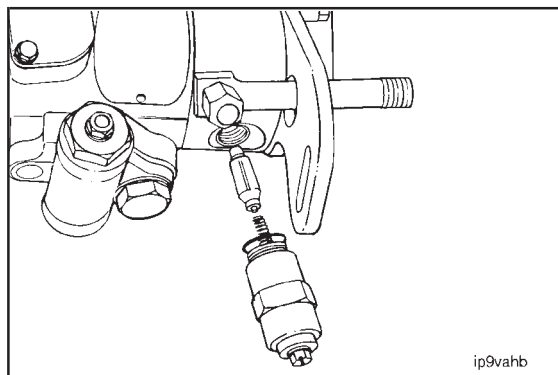

22 mm

Install the plunger, spring, solenoid and o-ring.



Torque Value: 15 N•m [11 ft-lb]

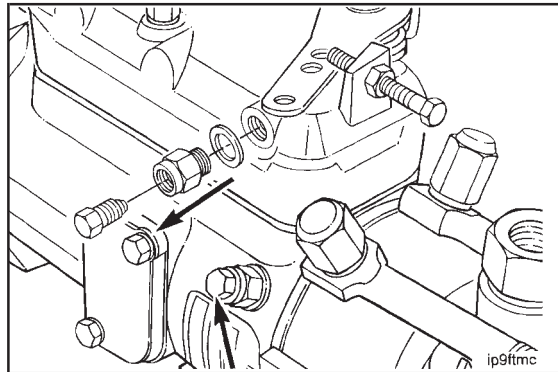

**Bleed Screws/Sealing Washers - Replacement (5-13)**

8 mm, 11 mm

Remove the screw, fitting and washer.

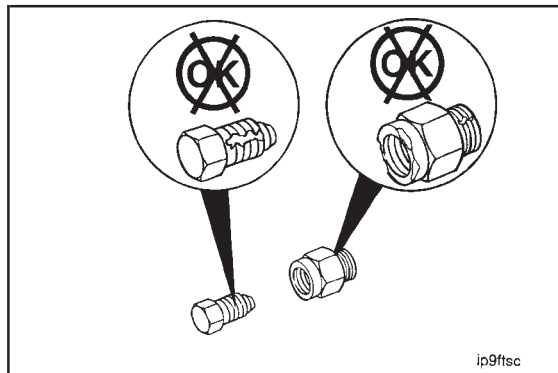

Inspect the threads and sealing surfaces.

If the fitting or bleed screw is damaged, replace the damaged components.



8 mm, 11 mm

Install the bleed screw, fitting and new sealing washer.

**Torque Value:** (Fitting) 7.3 N•m [65 in-lb]

**Torque Value:** (Bleed Screw) 4.5 N•m [40 in-lb]

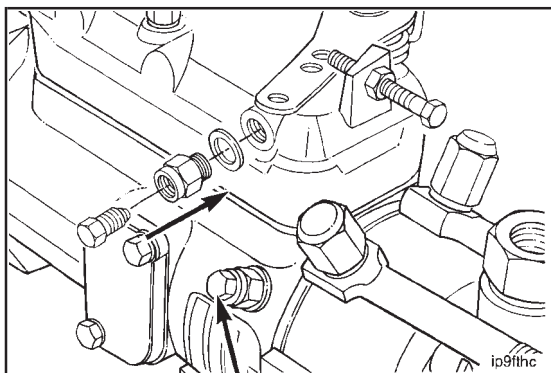

**Vent Fitting/Sealing Washer - Inspection/Replacement (5-14)**

16 mm

Remove the fitting and washer.

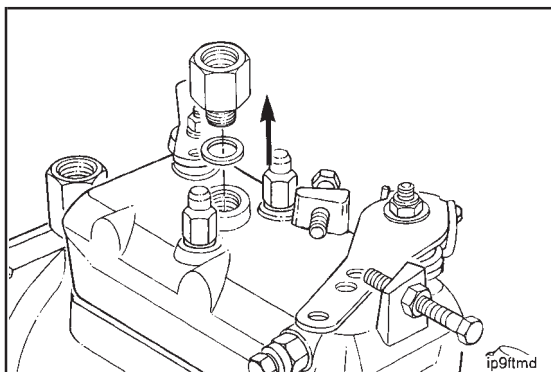

Inspect the sealing surfaces and verify that the orifice is open.

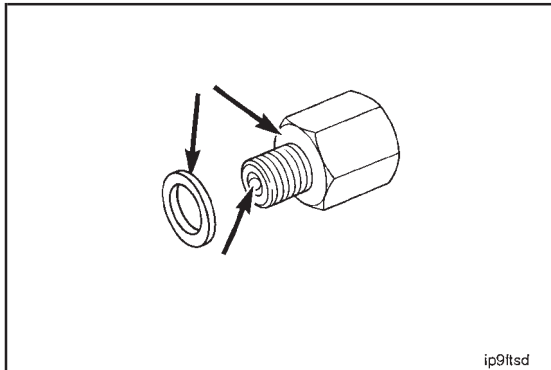

16 mm

Install a new washer and vent fitting.

**Torque Value:** 20.6 N•m [15 ft-lb]

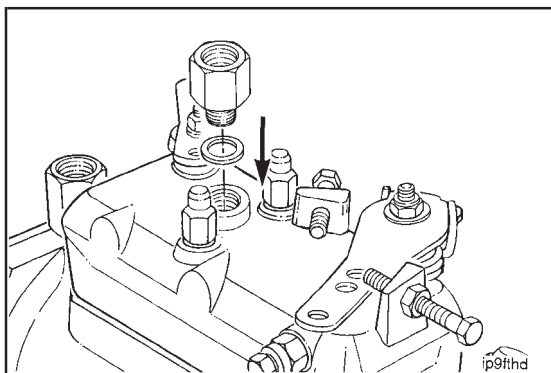

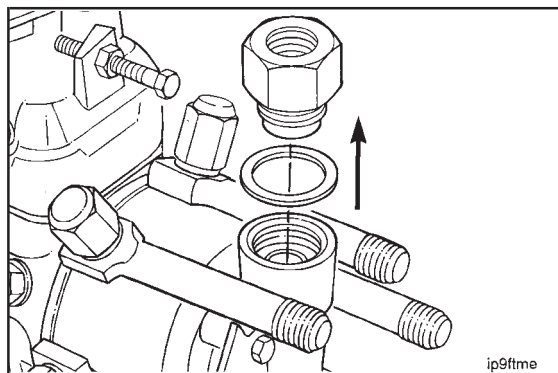

### Fuel Inlet Fitting/Sealing Washer - Replacement (5-15)

24 mm

Remove the fitting and washer.

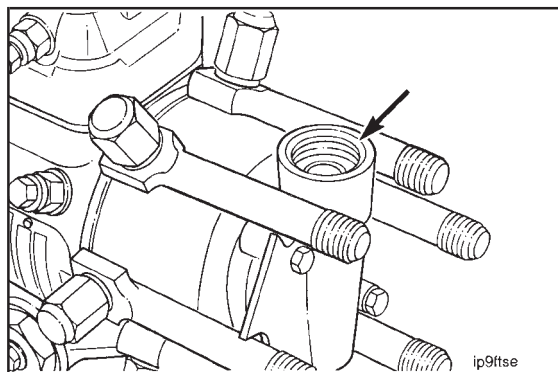

Inspect the surface for a leak path.

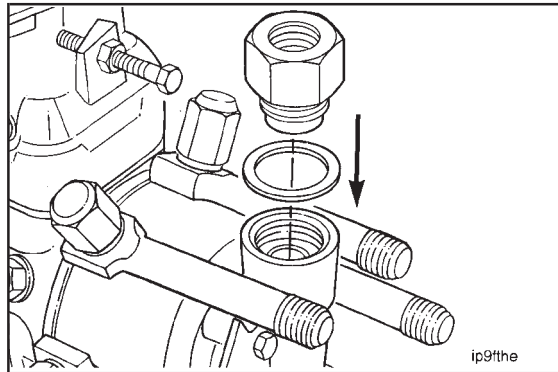

24 mm

Install a new washer and fitting.

**Torque Value:** 51 N•m [38 ft-lb]

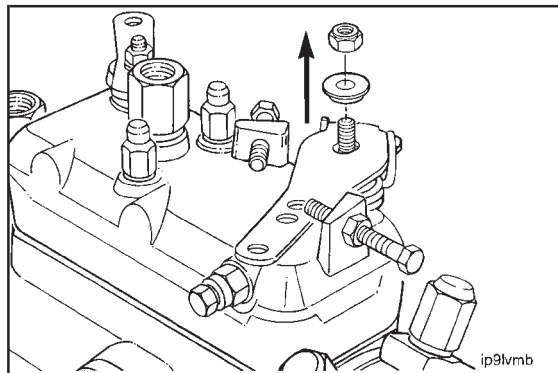

### Control Lever - Replacement (5-16)

8 mm

Remove the locknut.

Inspect the lever components:

1. Locknut
2. Bushing
3. Throttle Lever
4. Stop Arm
5. Washer
6. Torsion Spring
7. Spring Guide

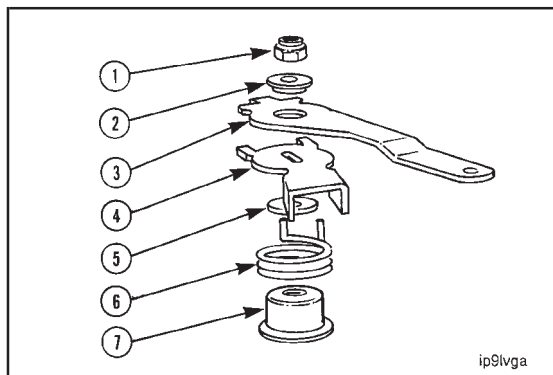

ip9lvga

Assemble the spring guide, torsion spring, washer and stop arm.

The stop arm must slide over flats of the shaft.

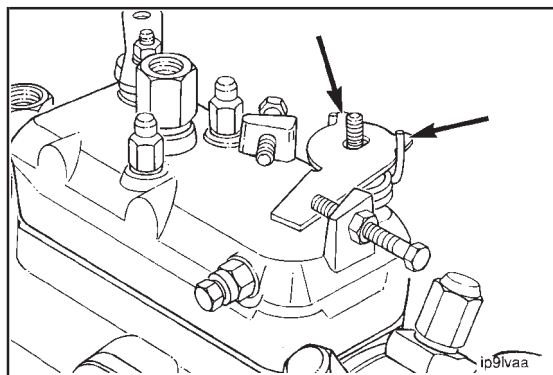

ip9lvaa

8 mm

Install the lever, bushing and locknut.

Torque Value: 3.4 N•m [30 in-lb]

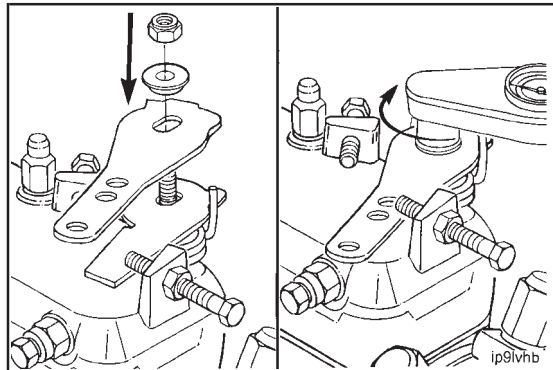

ip9lvhb

### Shutdown Lever/Spring - Replacement (5-17)

8 mm

Remove the locknut and washer.

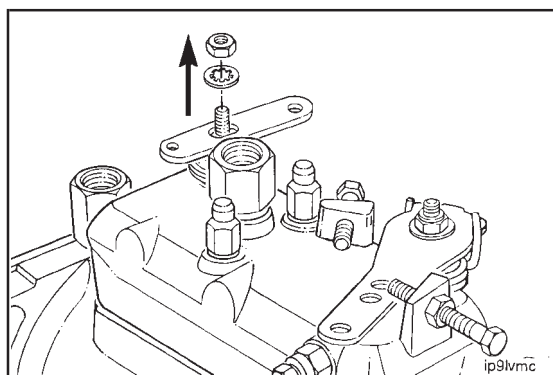

ip9lvmc

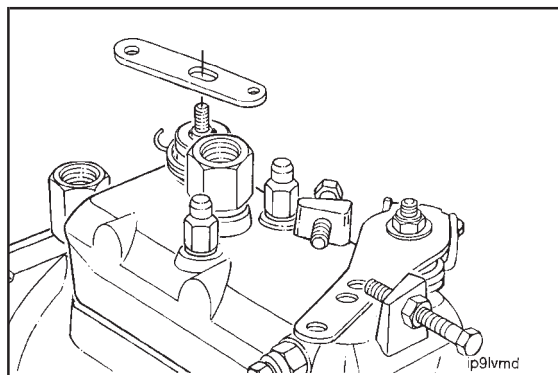

Lift off the lever while allowing the return spring to unwind.

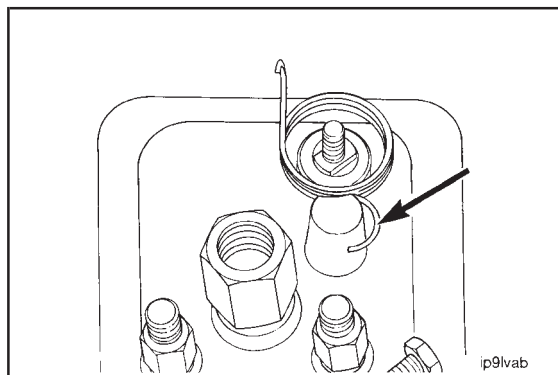

Position the return spring with one end of spring contacting the boss on the governor cover.

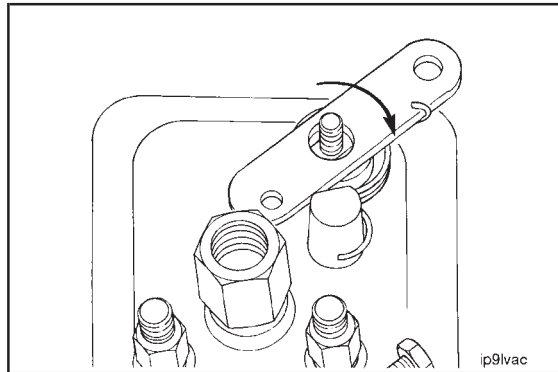

Hook the free end around the shut off lever and rotate the lever in a clockwise direction until it engages with the flats on the shut off shaft.

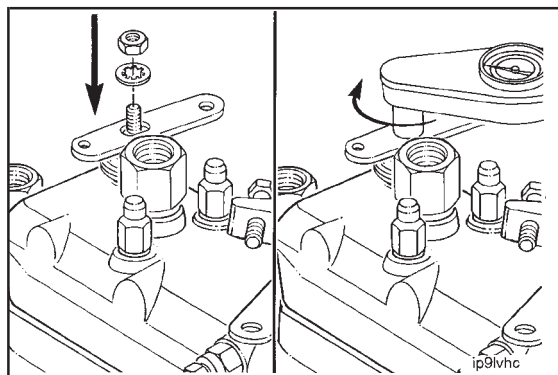

**8 mm**

Install the nut with a new lock washer.



**Torque Value:** 3.4 N•m [30 in-lb]



### Automatic Timing Advance - Disassembly (5-18)

8 mm

Remove the small plug and washer.

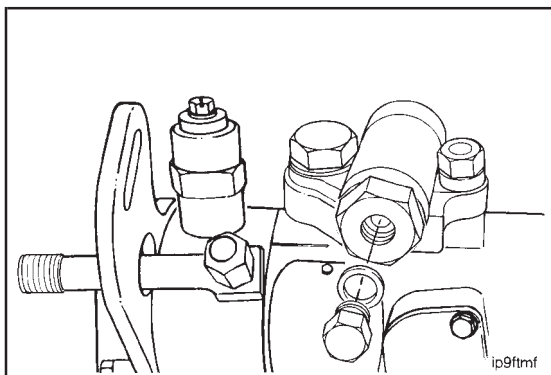

24 mm

The spring cap is under spring tension; remove the cap slowly.

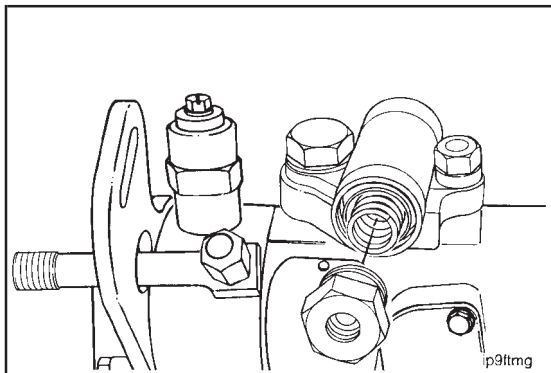

Remove the shims and springs.

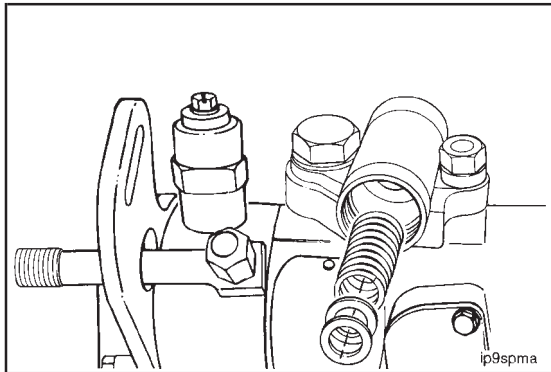

24 mm

Remove the pressure end plug and o-ring.

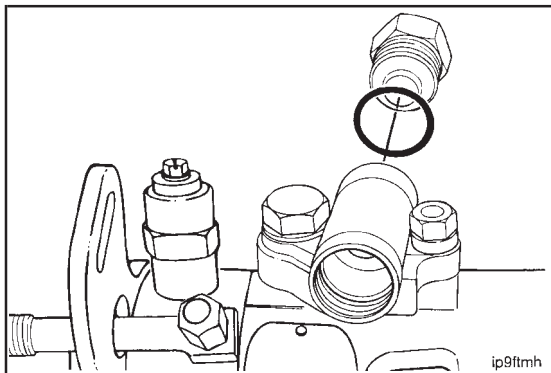

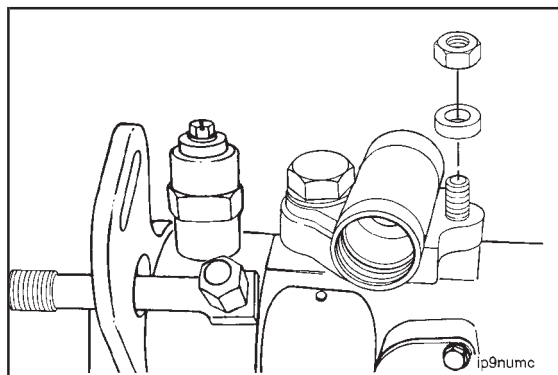

13 mm

Remove the cap nut and sealing washer.

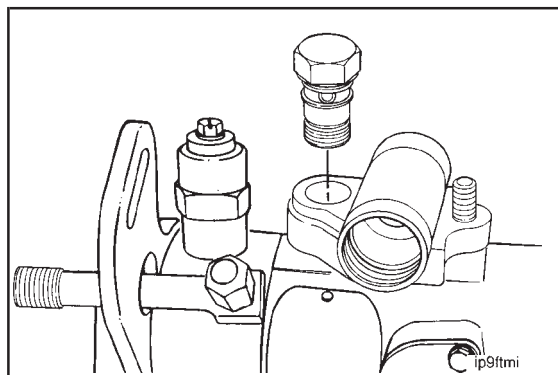

19 mm

Remove the head/locating fitting assembly.



Do not lose the check ball.

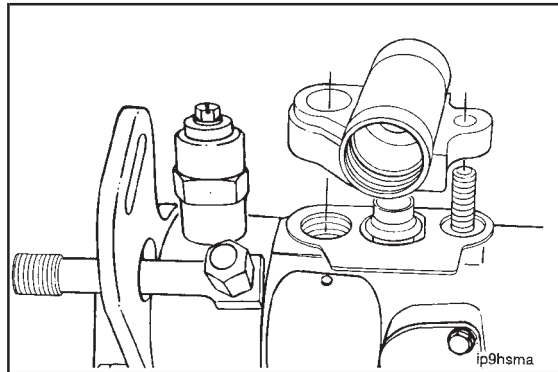

Remove the housing and slide the advance piston from the bore.

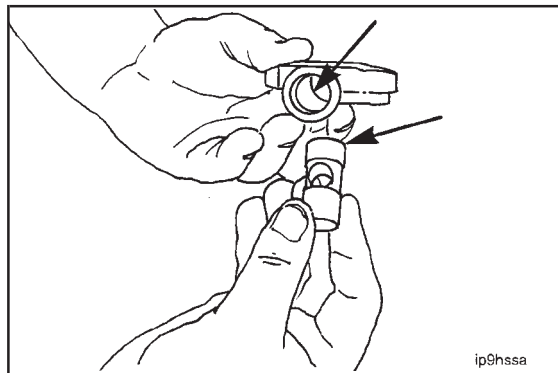

**Timing Advance Components - Inspection (5-19)**

Inspect the advance piston and housing for scoring.

Inspect the check ball and seat for erosion. Make sure the ball can move freely on the seat.

**Be sure the orifice in the side of the seat in the head locating fitting is open.**

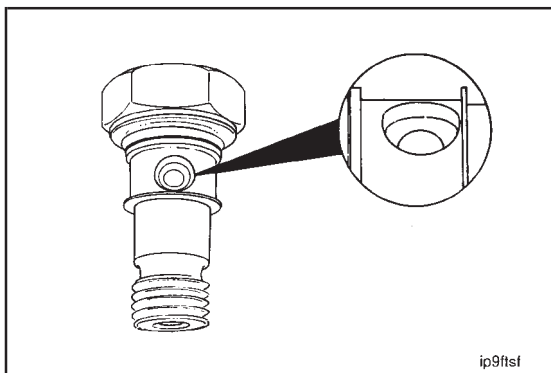

ip9ftst

Check that the cam ring is free to move in the fuel pump.

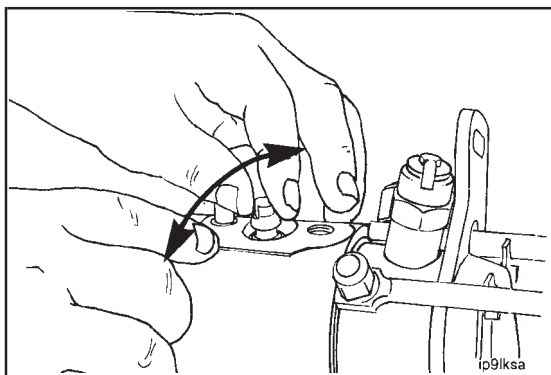

ip9iksa

**Timing Advance - Assembly (5-20)**

Position a new gasket on the injection pump housing.

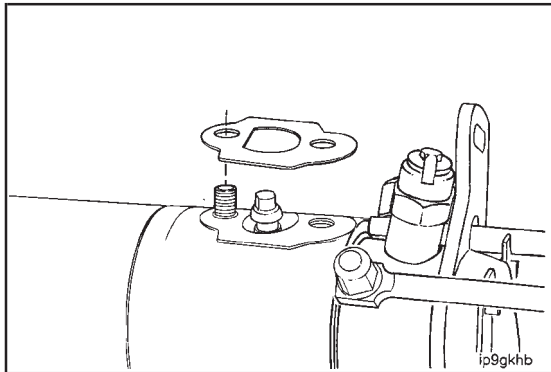

ip9gkhh

Insert the advance piston into the housing with the blank end toward the oil feed hole in the bore.

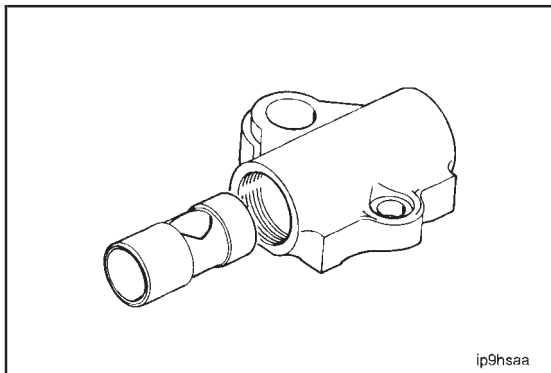

ip9hsaa

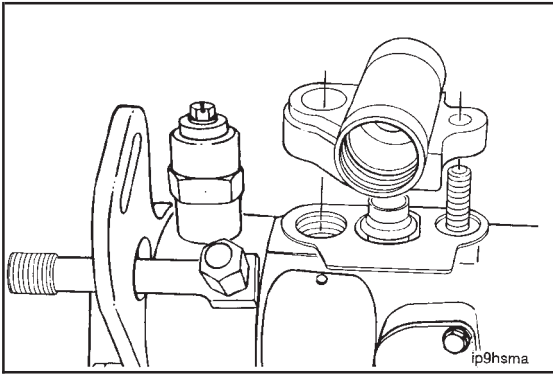

Position the advance housing over the stud in the injection pump with the cam advance screw positioned into the center bore in the piston.

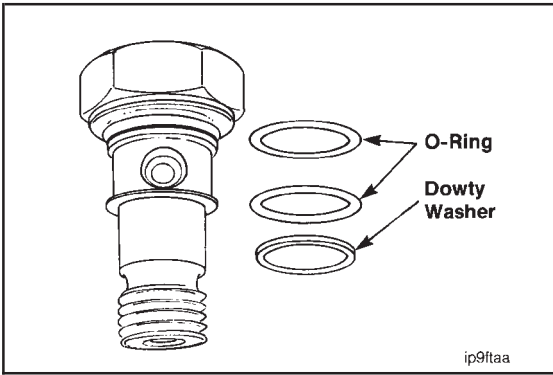

Install new o-rings on the head - locating fitting.

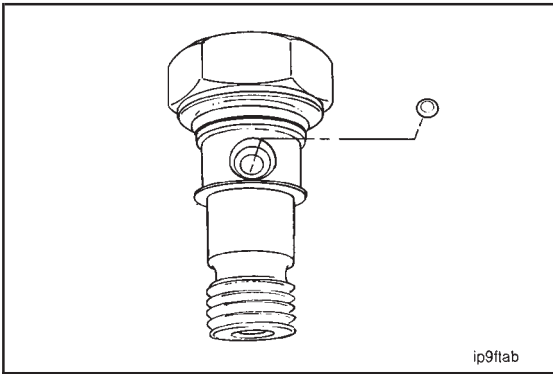

Position the check ball in the head/locating fitting.

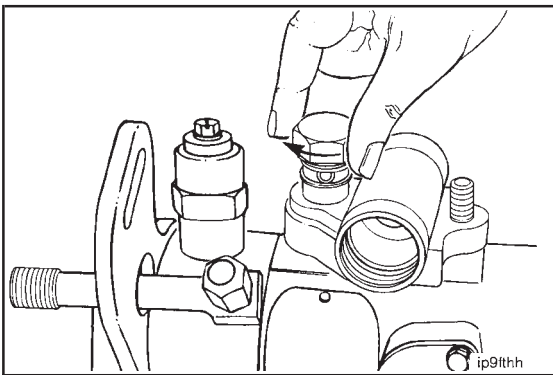

Position head/locating fitting through the advance housing and hand tighten.



13 mm, 19 mm

Install cap nut and a new washer. Tighten the cap nut and head locating fitting progressively and evenly.

Torque Value		
(Cap Nut)	30 N•m	[22 ft-lb]
(Locating Fitting)	40 N•m	[29 ft-lb]

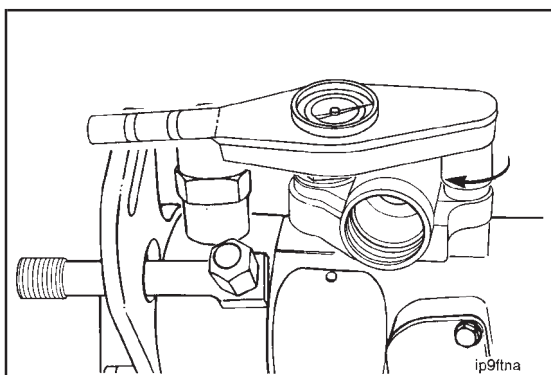

Verify that the piston moves freely in the bore.

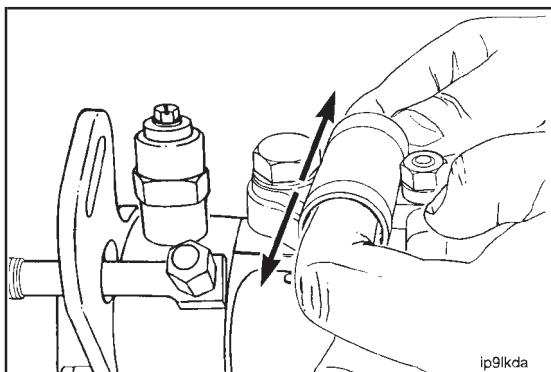

Install the springs and shims into the pocket end of the advance piston.

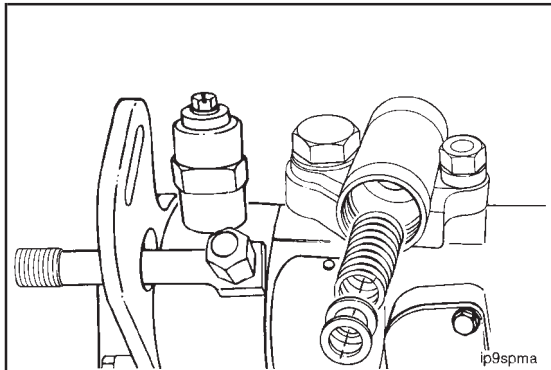

Install a new o-ring on the spring cap and place the shims in the pocket.

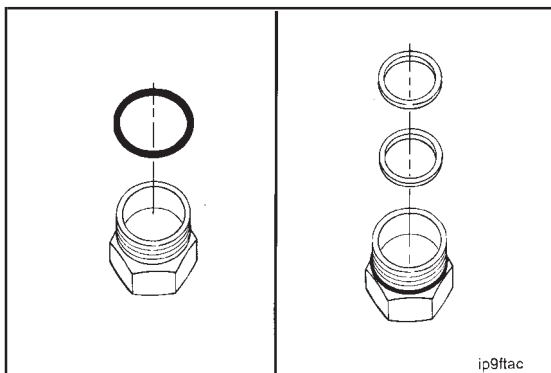

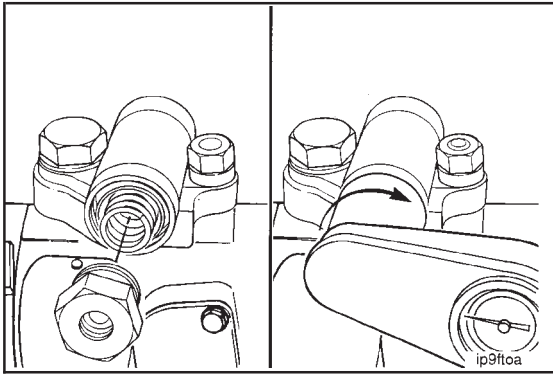

24 mm

Install and tighten the spring cap on the advance housing.



**Torque Value:** 24 N•m [17.5 ft-lb]

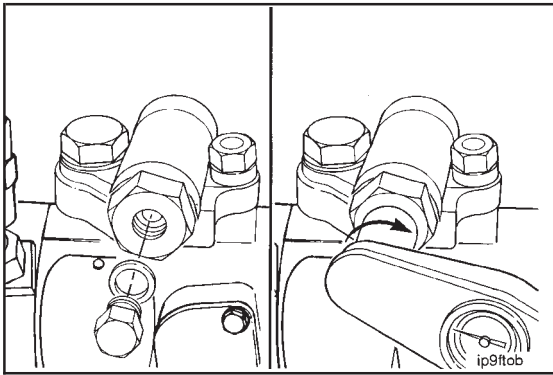

8 mm

Use a new washer and install the spring cap plug.



**Torque Value:** 2.3 N•m [20 in-lb]

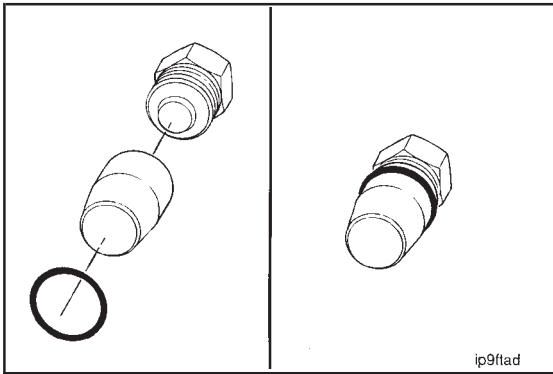

**21 mm Protective Sleeve Part No. 3376931**

Install a new o-ring on the pressure end cap. Use the protective sleeve to avoid damaging the o-ring.

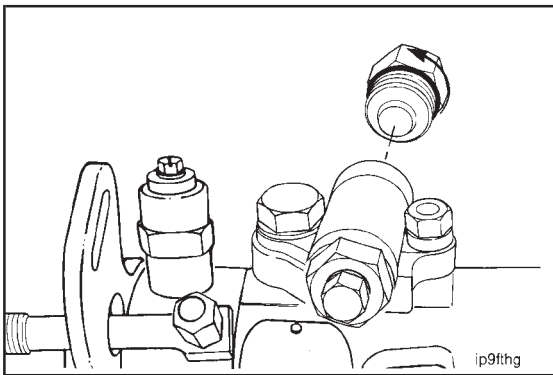

24 mm

Install and tighten the cap.



**Torque Value:** 24 N•m [17.5 ft-lb]



### Injection Pump Repairs (5-21)

#### Injection Pump Timing - Stanadyne DB4 (5-22)

Remove the timing line cover from the injection pump.

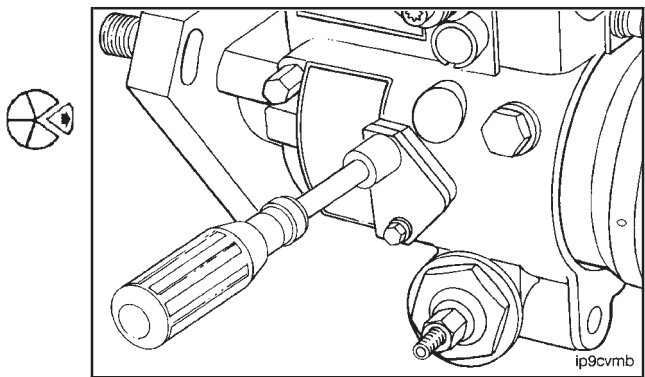

Rotate the driveshaft in the direction of rotation and align the timing line on the weight retainer hub with the line on the cam ring.

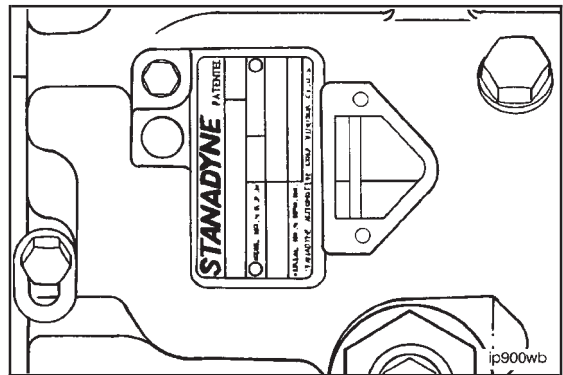

Tighten the driveshaft locking screw to hold the injection pump in the lock timed position.

**Torque Value:** 12 N•m [106 in-lb]

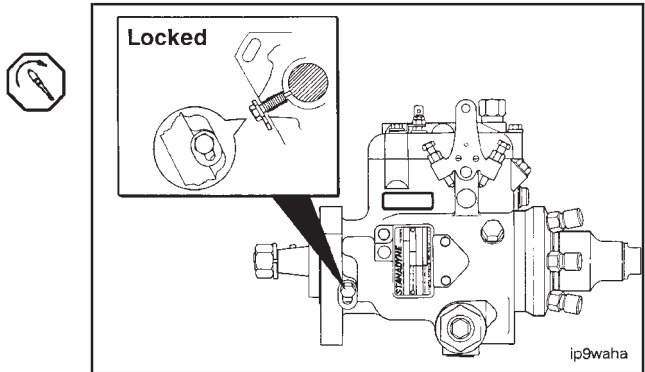

Verify the timing marks are aligned after tightening the locking screw. If the alignment is not correct, loosen the locking screw and readjust.

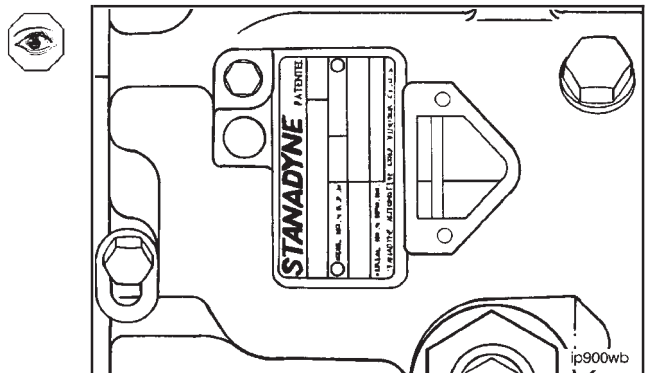

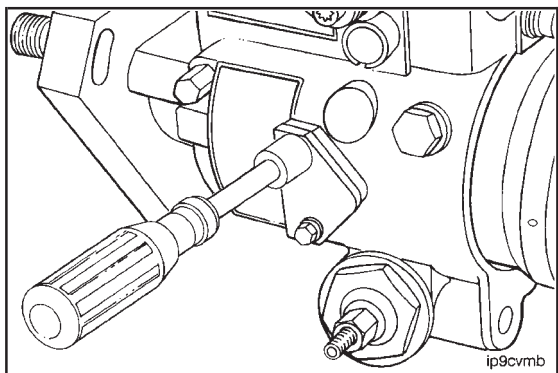

Install the timing line cover.  
**Torque Value:** 2 N•m [17 in-lb]

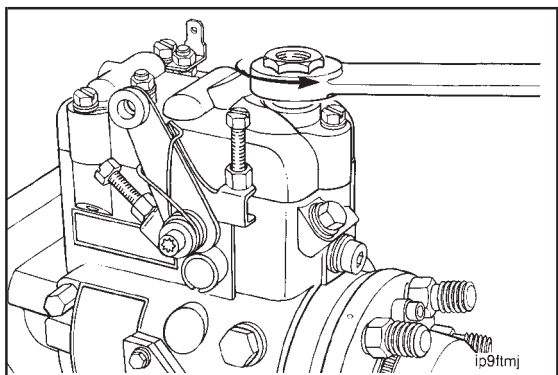

**Return Connection Replacement, Stanadyne DB4 (5-23)**

Remove the fuel return connection.

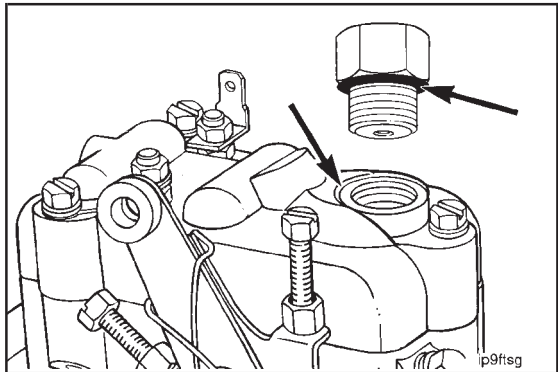

Inspect the sealing surfaces on the connection and the pump. Inspect the sealing o-ring and check ball.

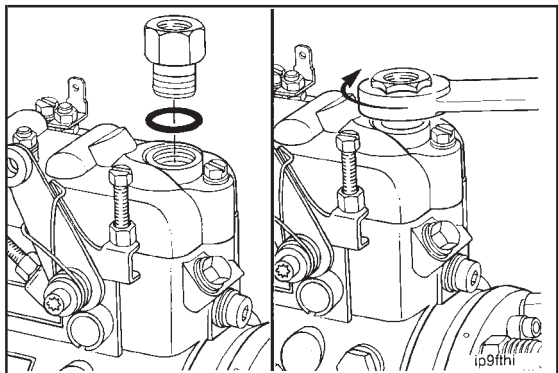

Install a new sealing o-ring and tighten the return connection.

**Torque Value:** 11 N•m [97 in-lb]

**Shutoff Solenoid Replacement, Stanadyne DB4 (5-24)**

The Stanadyne injection pump is equipped with one of two types of electrical shutoff devices. Energized to run (ETR) solenoids are the most common. They are energized continuously while the engine is running and when de-energized will cause the engine to shut off. Note the location of the solenoid arm (1) in the illustration.

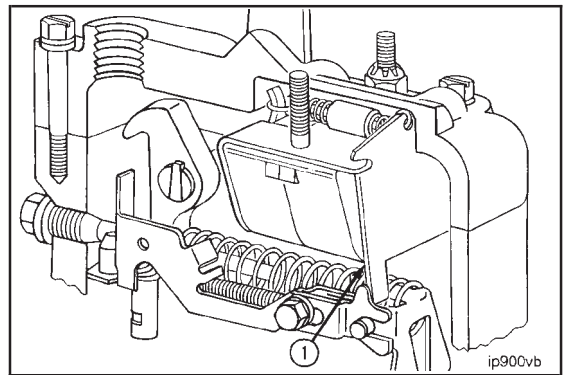

The energized to shutoff (ETSO) solenoids are used less frequently. These are designed to be energized only momentarily when engine shutoff is desired. Note the location of the solenoid arm (1) in the illustration.

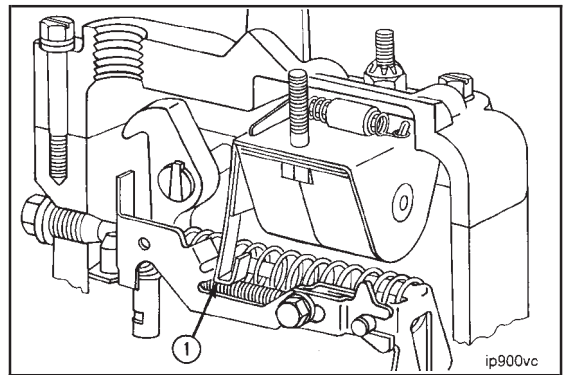

Remove the top cover mounting screws.

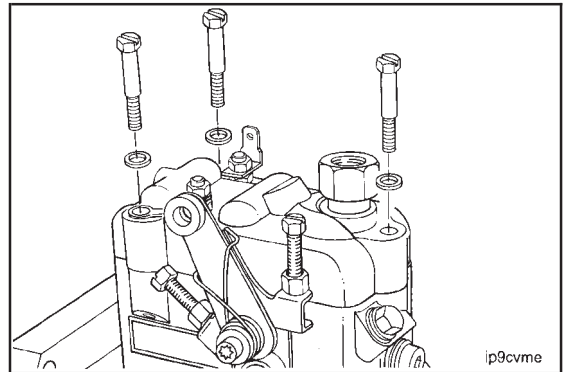

Remove the four solenoid mounting nuts, grounding strap, washers and terminal.

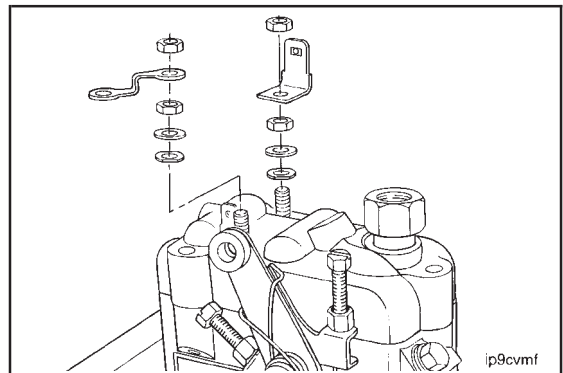

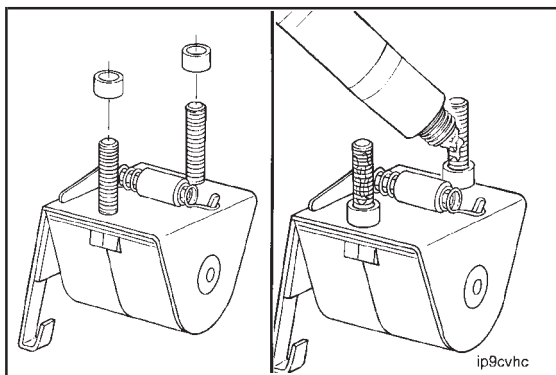

Install new insulating tubes onto the terminal studs of the new solenoid. Apply dielectric grease to the terminal studs and to the area the solenoid will come into contact with the top cover.

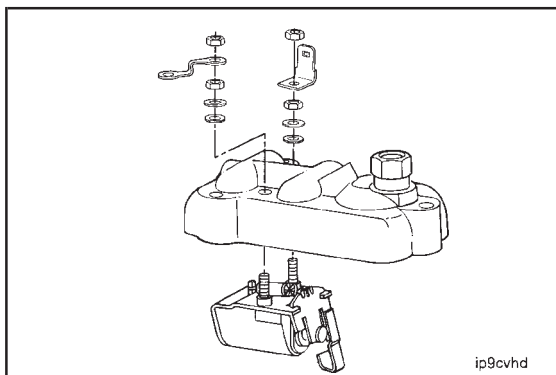

Install the solenoid to the top cover.

**Torque Value:** 14 N•m [12 ft-lb]

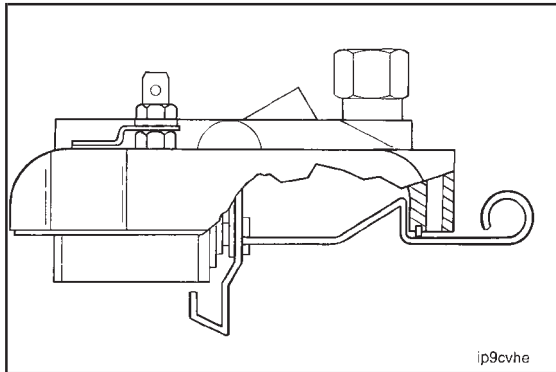

Use the Stanadyne ETR solenoid arm retaining tool to make sure the arm is in the correct position during the top cover installation.

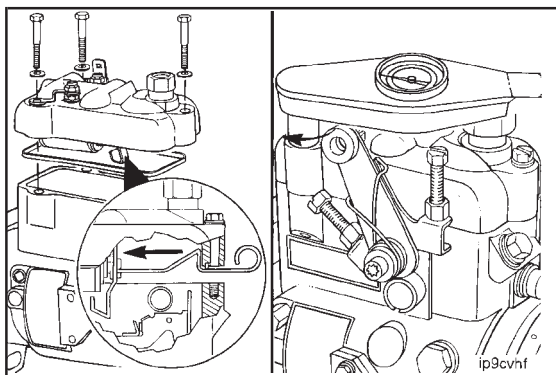

Install the top cover and gasket to the injection pump. Twist the retaining tool to release it from the arm. Slide the tool out from between the top cover and pump.

**Torque Value:** 4.6 N•m [41 in-lb]



In the event that the retaining tool is not available, install the top cover as follows:

Move the shutoff lever to the stop position.

**NOTE:** Extreme care must be taken in assembling the cover to the pump to make sure the shutoff arm is in correct contact with the linkage hook tab.

Install the cover to the pump at a downward angle from the driveshaft end of the pump, then slide the cover horizontally into position.

**Torque Value:** 4.6 N•m [41 in-lb]

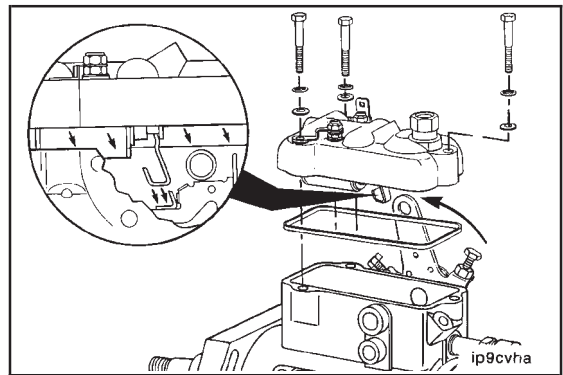

Install the top cover, ETSO solenoid and gasket to the injection pump.

Make sure the solenoid arm is between the pump housing and linkage tab as shown in the illustration.

**Torque Value:** 4.6 N•m [41 in-lb]

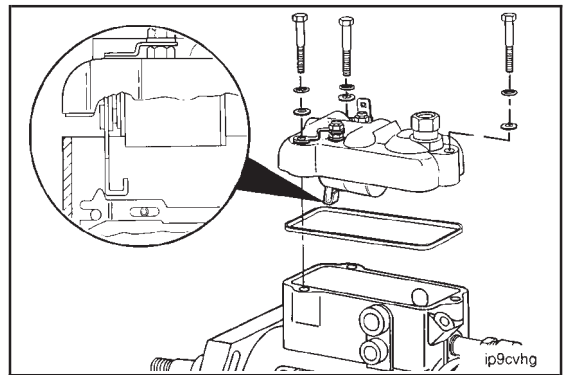

**Speed Droop Adjustment Off Engine - Stanadyne DB4 (5-25)**

Loosen the speed droop adjustment locking cap.

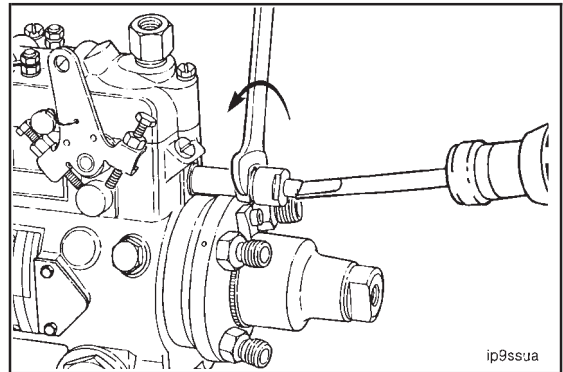

Turn the droop adjustment screw counterclockwise until it stops. Then, turn the screw five complete revolutions in the clockwise direction.

The governor is now adjusted to minimum droop. Adjustments to increase or decrease governor sensitivity can be made after the injection pump is installed to the engine.

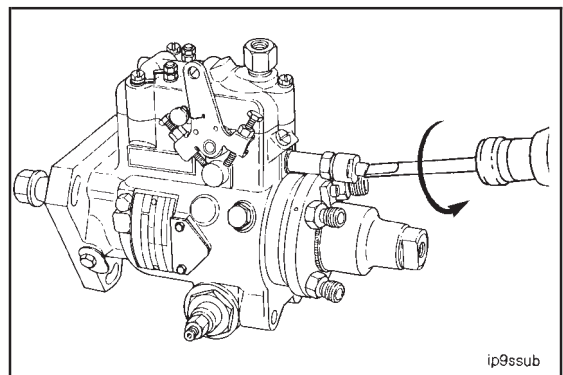

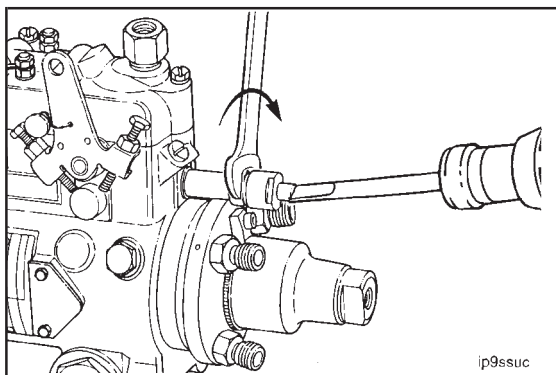

Tighten the droop adjustment locking cap. Hold the adjustment screw with a screwdriver to prevent movement when the locking cap is tightened.

**Torque Value:** 7.5 N•m [65 in-lb]

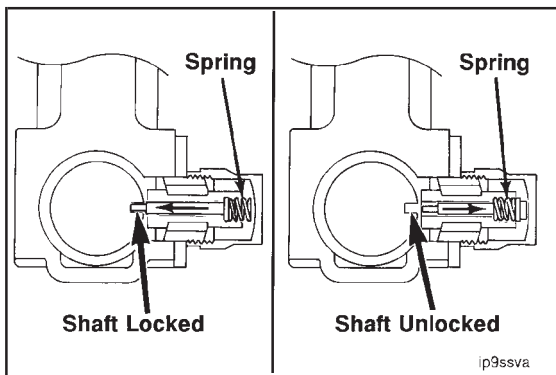

**Injection Pump Timing - Nippondenso EP9 (5-26)**

The injection pump has a plastic timing pin and spring located under the cap on the outboard side of the pump. This pin locates the pump shaft to correspond with TDC for cylinder No. 1. After the pump is installed, the spring is placed **under** the head of the timing pin and the cap is installed.

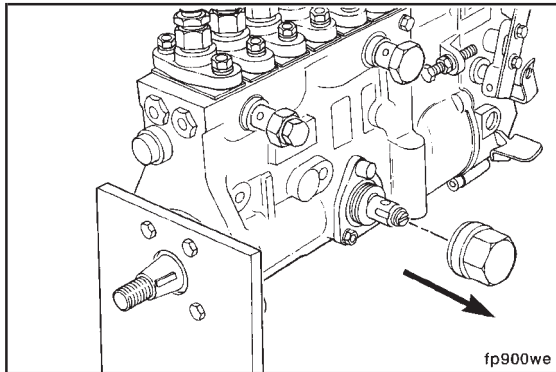

**34 mm**

Mount the pump on a suitable bracket.



Remove the cap from the pump locking device. The cap is located on the outboard side of the pump.

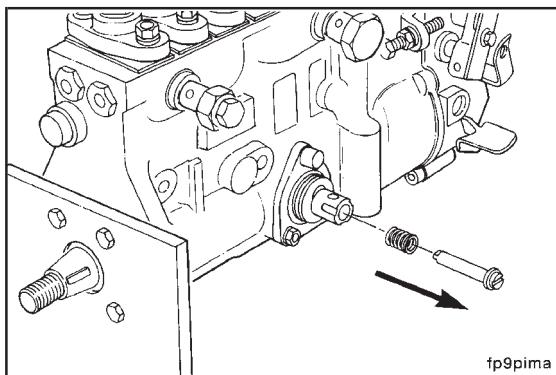

Remove the plastic timing pin and spring.



27 mm

Install the nut on the pump shaft.

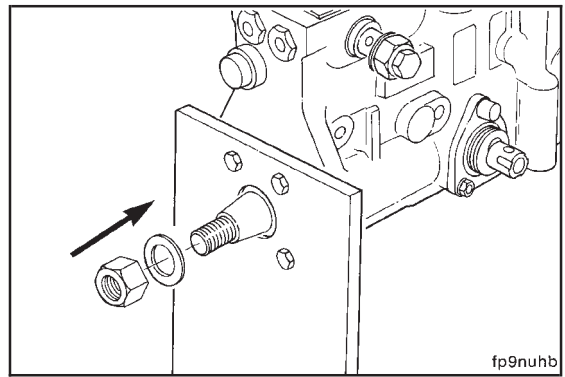

Install the timing pin first, then the spring.

**Service Tip:** Use the slot in the end of the timing pin as a reference for properly positioning the timing pin. The slot must be horizontal to the pump in order for the pin to engage the slot in the pump shaft.

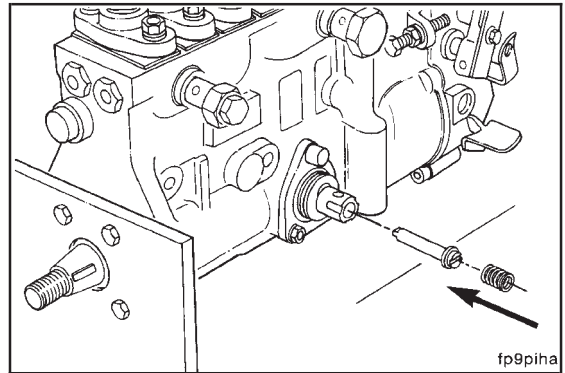

27 mm

Depress the spring and rotate the pump shaft until the tip of the timing pin goes into the slot in the pump shaft. **The keyway in the shaft will be at approximately the 2 o'clock position.**

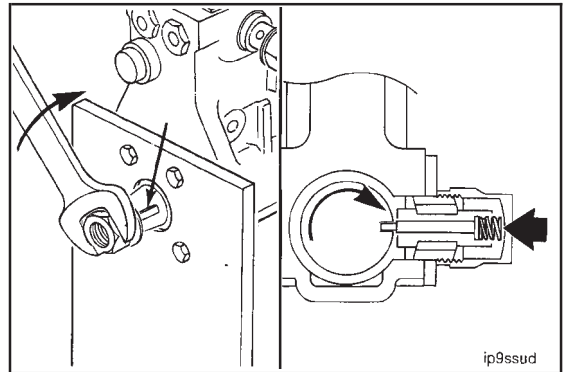

**Caution:** Although unlikely, it is possible that the timing pin will match the pump notch when the timing pin is first inserted. If so, the pump will be locked. Do not exert more than 7 N•m [10 ft-lb] torque to turn the pump shaft. If the pump shaft does not turn with 7 N•m [10 ft-lb] torque, remove the spring and timing pin, then rotate the pump slightly. Repeat the previous step again.

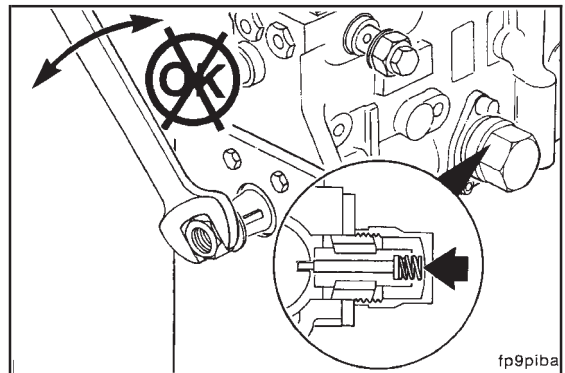

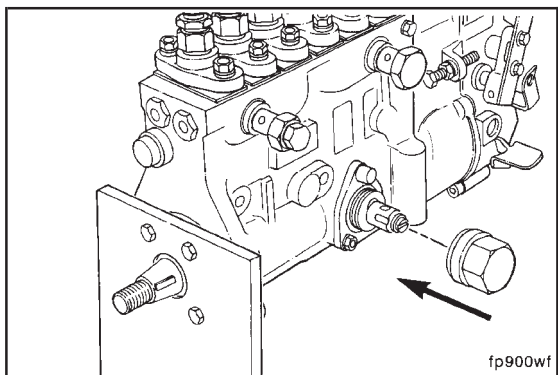

Install the cap loosely (finger tight).

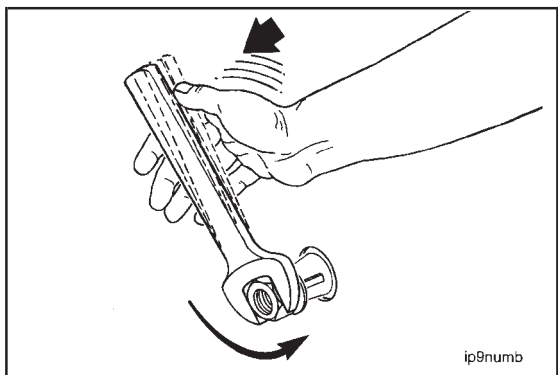

27 mm

Remove the nut from the pump drive shaft by striking the wrench with a sharp blow in a counterclockwise direction.

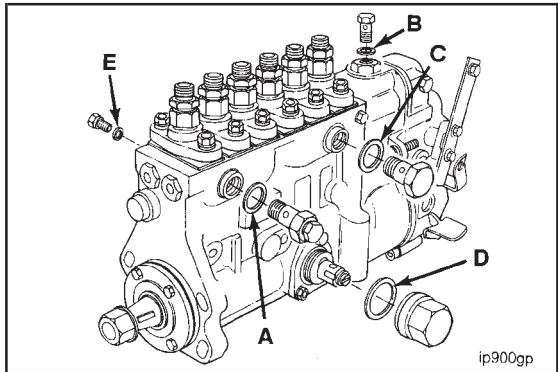

**Seals Replacement, Nippondenso EP9 (5-27)**

Item	Type of Seal	Torque
A	Sealing washer, 24 N•m [18 ft-lb]	
B	Sealing washer, 14 N•m [10 ft-lb]	
C	Sealing washer, 27 N•m [20 ft-lb]	
D	Copper washer only, 70 N•m [50 ft-lb]	
E	Copper washer (Bleed screw), 5 N•m [36 in-lb]	

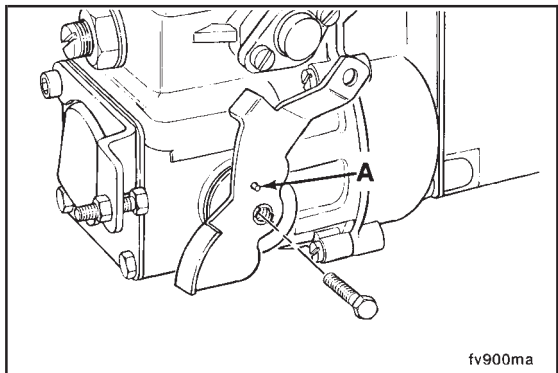

**Shut Down Lever or Spring Replacement, Nippondenso EP9 (5-28)**

10 mm

Remove the retaining screw.



Remove the shut down lever (A) spring housing (B) and return spring (C).

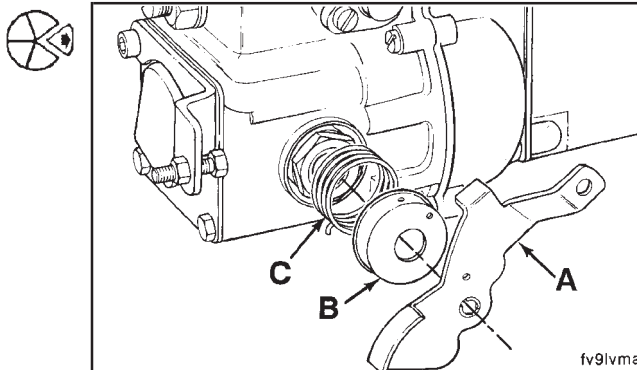

Install the spring as illustrated.

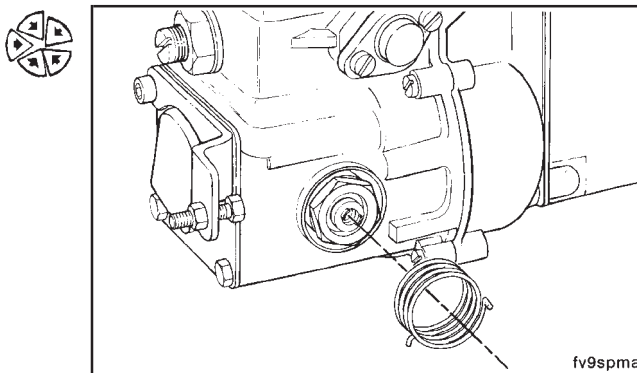

Install the spring housing over the spring aligning the spring with the illustrated hole in the housing.

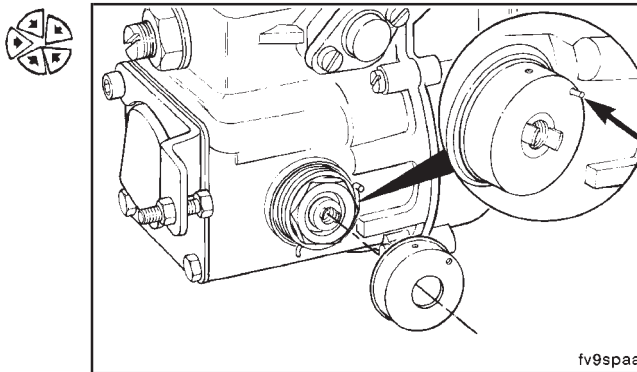

**Metal awl or pick**

Load the spring by rotating the spring/housing counter-clockwise approximately 1/4 turn.

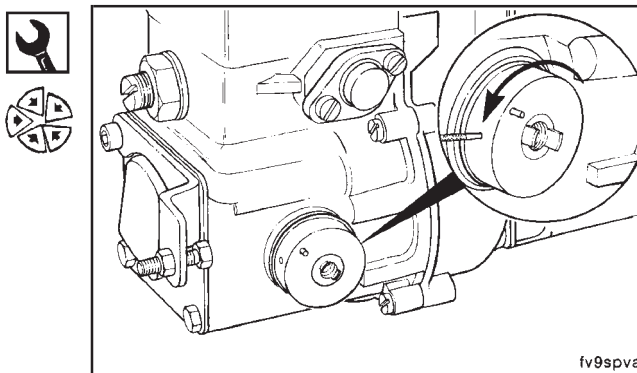

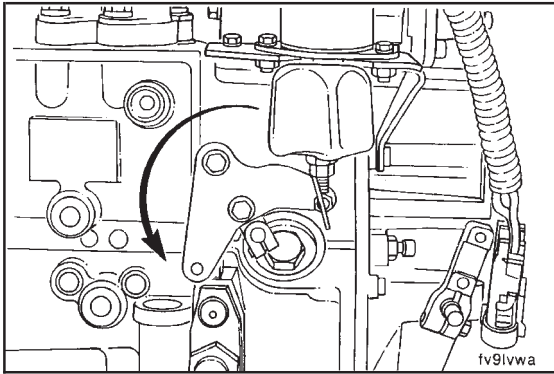

10 mm

Hold the spring in the loaded position and install the lever.



**NOTE:** If the shutdown shaft slides into the housing, thread the retaining screw into the shaft and slide the shaft to its original position. Visually inspect the o-ring for distortion or damage.

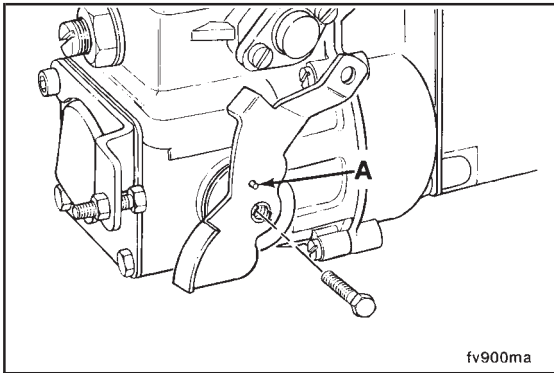

10 mm

Install the retaining screw making sure the spring aligns to the hole in the lever.

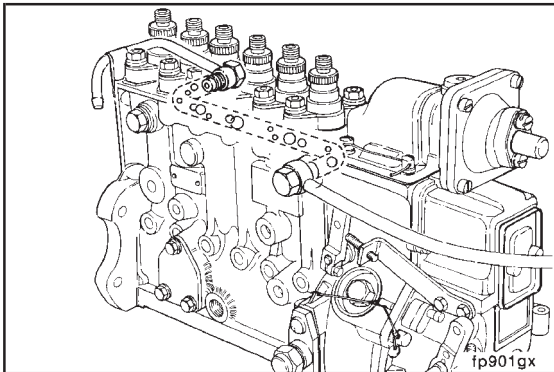

**Pressure Relief Valve and Sealing Washer Replacement, Bosch P7100 (5-29)**

The pressure relief valve arrangement on the Bosch P7100 injection pump in the supply side of the fuel circuit creates a self-bleeding system for air introduced during replacement of the supply side components.

A sticky or malfunctioning relief valve can result in engine miss, low power or hard starting.

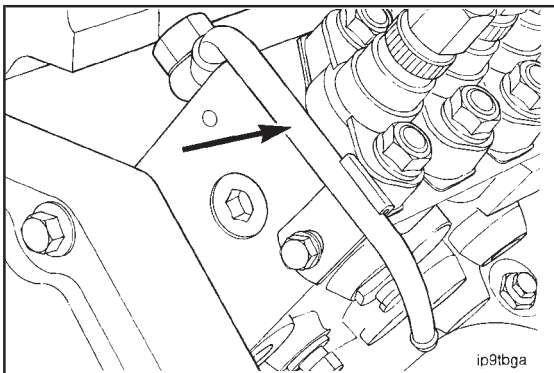

The Bosch P7100 injection pump has a jump-over tube to route return fuel and entrapped air from the pressure relief valve directly to the supply tank.

Mount the pump in a suitable bracket and hold pump with a vise.

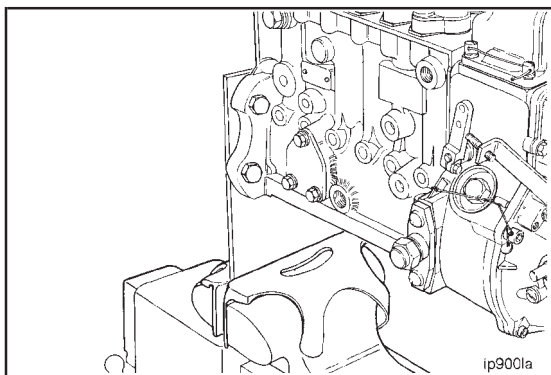

**19 mm**

Remove the pressure relief valve and sealing washers.

Remove the jump-over tube.

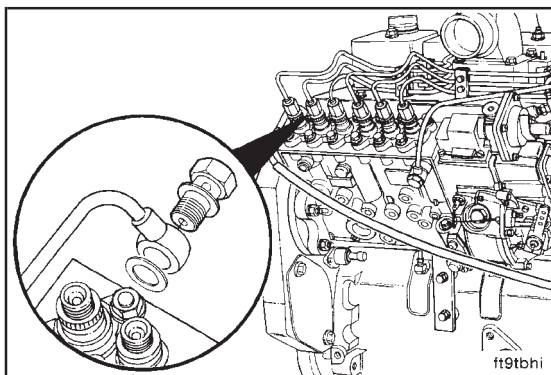

Thoroughly flush the pressure relief valve with a cleaning solution.



Use a small screwdriver to check that the check ball is not sticking in the pressure relief valve assembly.

A sticky check ball will result in engine low power and hard starting.

Replace the relief valve assembly if necessary.

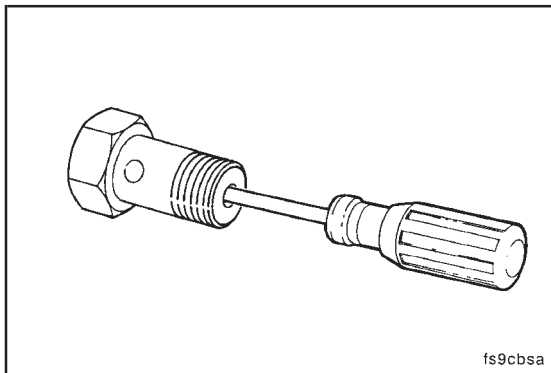

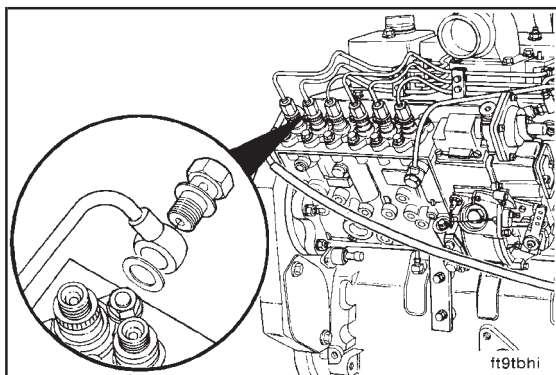

19 mm

Install the pressure relief valve, jump-over tube, and sealing washers in the reverse order of removal.

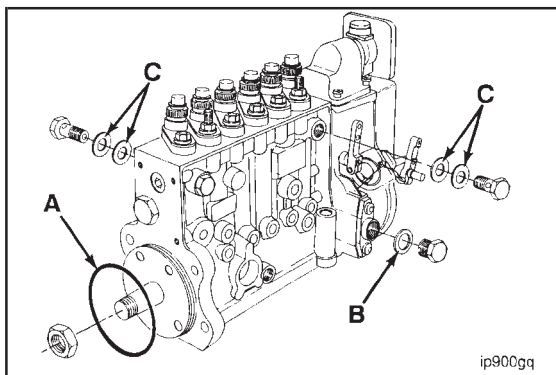

**Seal Replacement, Bosch P7100 (5-30)**

Item	Type of Seal
A	O-Ring Seal
B	Sealing Washer
C	Sealing Washers (Rubber Coated)

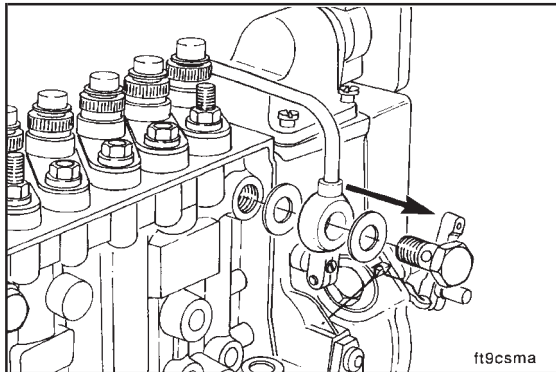

**Fuel Inlet Banjo Connector Replacement, Bosch P7100 (5-31)**



19 mm



Remove the fuel inlet banjo connector and sealing washers.



Thoroughly flush the inlet connector with a cleaning solution to ensure it is not blocked with foreign debris.



Replace the fuel inlet banjo connector if the threads are ruined.

**19 mm**

Install the fuel inlet banjo connector and new sealing washers in the reverse order of removal.

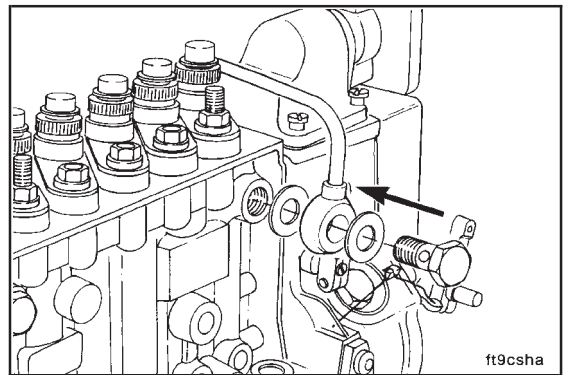

**Fuel Shut Off Solenoid Replacement, Bosch P7100 (5-32)**

**10 mm**

Remove and replace the shut off solenoid with the part number facing outward as illustrated.

**Torque Value:** 9 N•m [7 ft-lb]

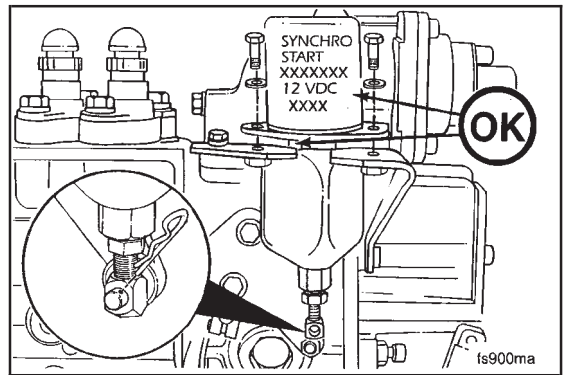

**Fuel Shut Off Solenoid Adjustment, Bosch P7100 (5-33)**

**NOTE:** The fuel pump solenoid must be adjusted on the vehicle to access the voltage supply.

Connect the solenoid wiring harness to the vehicle wiring harness.

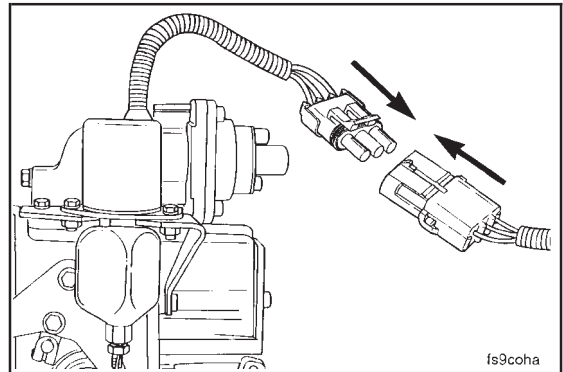

Turn the key to the "ON" position. This will energize the red (hold) wire and black (common) wire.

This is the low current hold-in coil and must be energized continuously during this adjustment.

**NOTE:** Do not turn the key to the "START" position at this time. This will energize the white (pull-in) wire.

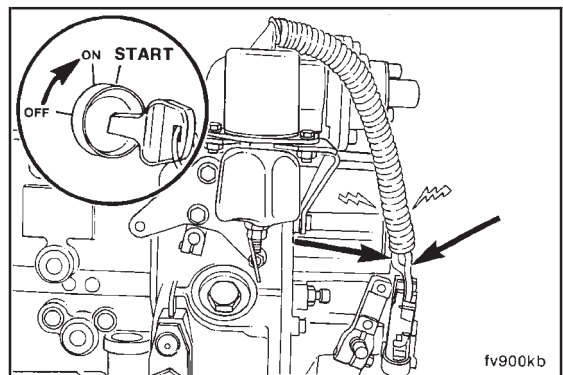

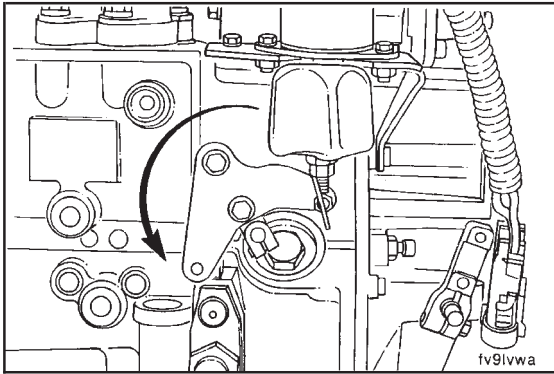

Move the shut off lever by hand to the full run position.

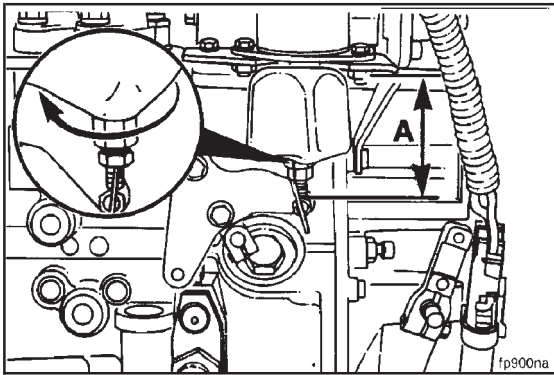

**10 mm, 16 mm**

Adjust the solenoid linkage to dimension A. Dimension A is measured from the bottom surface of the solenoid mounting bracket to the top of the pivot pin. When properly adjusted the plunger is magnetically held in with the shut off lever in the absolute full run position. Turn the large hex on the end of the plunger to make adjustments.

**Solenoid Run Dimension**

---

A = 66.9 mm [2.6 in]

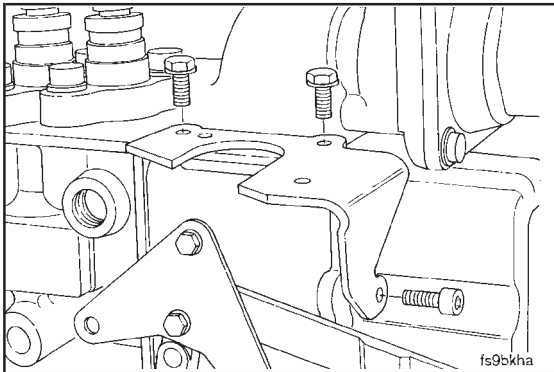

**Fuel Shut Off Solenoid Bracket Replacement, Bosch P7100 (5-34)**

Preparatory Step:

Remove shut off solenoid.



**8 mm, 5mm Allen**

Remove and replace the bracket as illustrated.

**Torque Value:** Top Capscrews (2) 7 N•m [5 ft-lb]  
Side Capscrew (1) 10 N•m [7.4 ft-lb]

**Fuel Pump Shut Off Lever Replacement, Bosch P7100 (5-35)**

Preparatory Step:

Remove the shut off solenoid.



8 mm, 10 mm

Remove the capscrews holding the lever bracket to the lever.

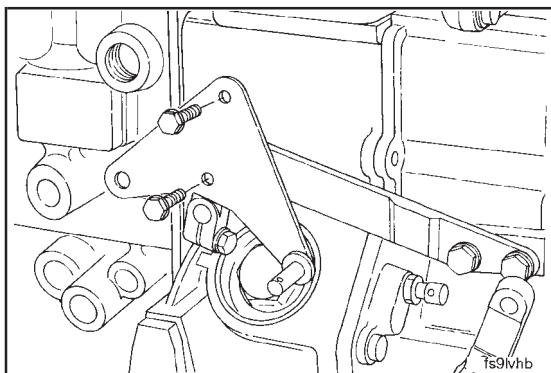

8 mm

Remove the capscrew holding the shut off lever to the shut off shaft.

**NOTE:** The shut off lever is indexed to the shaft with a Woodruff key.

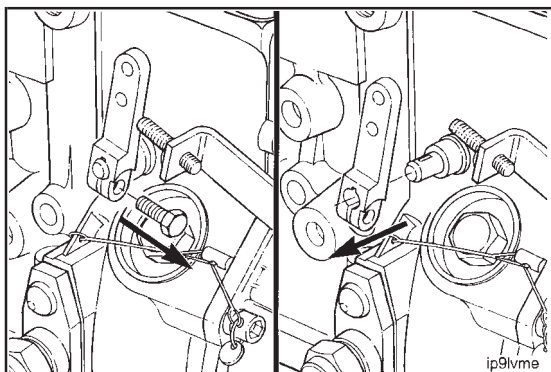

8 mm, 10 mm

Install in the reverse order of removal.

Adjust the shut off solenoid. Refer to Procedure (5-29).

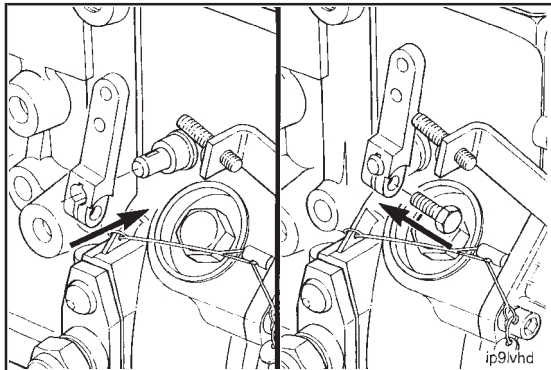

**Throttle Lever Replacement, Bosch P7100 (5-36)**

8 mm

Remove and replace the throttle lever as illustrated.

**NOTE:** The throttle is indexed on the throttle shaft with a Woodruff key.

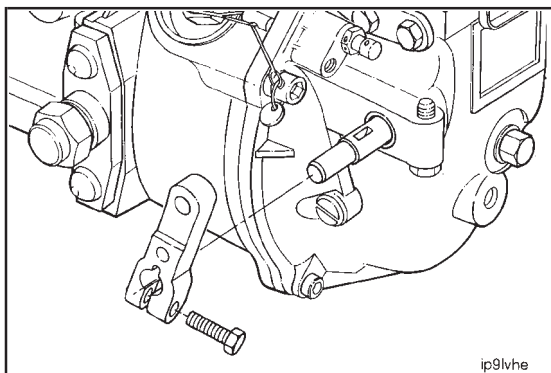

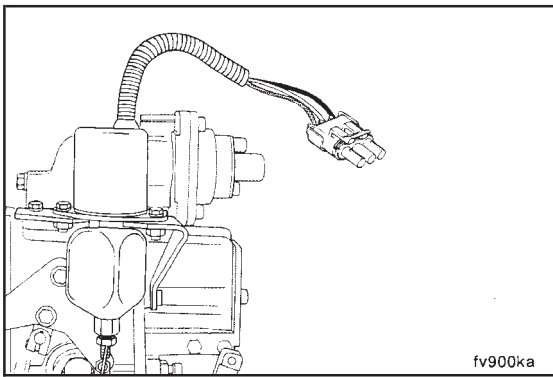

fv900ka

### Shutdown Solenoid Inspection, Bosch P7100 (5-37)

Engines using the Bosch P7100 fuel injection pump with the RQVK governor are equipped with the synchro-start fuel shut off solenoid to actuate the shut off lever. Both 12 volt and 24 volt external fuel shut off solenoids are available.

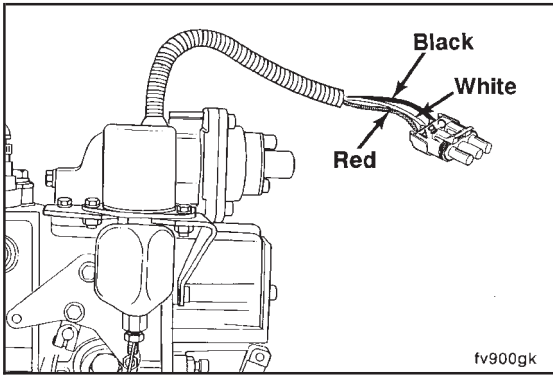

fv900gk

The synchro-start has a weatherpack connector with 3 wires in it.

Color	Description	Weatherpack Port
Black	Ground	'C'
White	Pull In	'B'
Red	Hold In	'A'

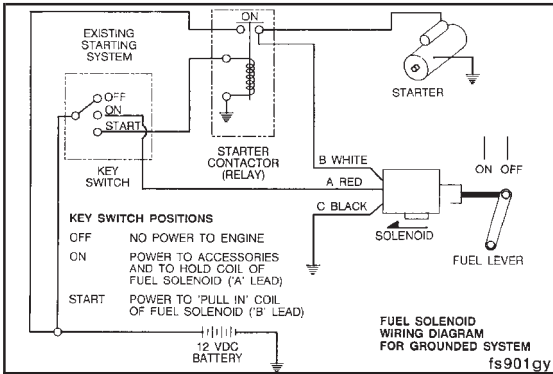

### Wiring Guidelines

Refer to the chart below to find the correct gauge size and length of continuous wire for the white (pull-in) wire, which connects to the solenoid wiring.

Gauge	Length of Wire		
	0-4.5 ft	0-7.0 ft	0-11 ft
	14	12	10

**NOTE:** 14 gauge wire is required for the red (hold-in) wire, which connects to the "Run" terminal on the ignition switch.

**NOTE:** The black (ground) wire must be the same size as the white (pull-in) wire.

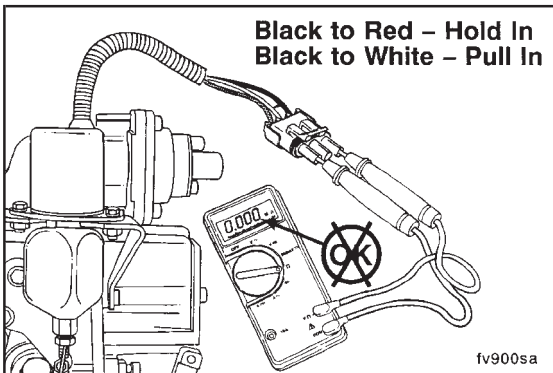

fv900sa

### Solenoid Resistance Check



The synchro-start solenoid can be checked using a voltmeter. Check the solenoid resistance.

Solenoid Voltage	Resistance Min Ohms	
	Pull-In	Hold-In
12	0.22	11.1
24	0.82	41.3

**Solenoid Voltage Check**

If the Synchro-Start solenoid checks good, the problem is with the wiring circuit to the solenoid.

To perform the solenoid voltage check, connect the wiring harness and apply voltage to the solenoid with the ignition key as follows:

1. With the key in the run position, check the voltage hold-in.
2. With the shut down lever held in the shut down position, move the key to the start position and check the pull-in voltage.

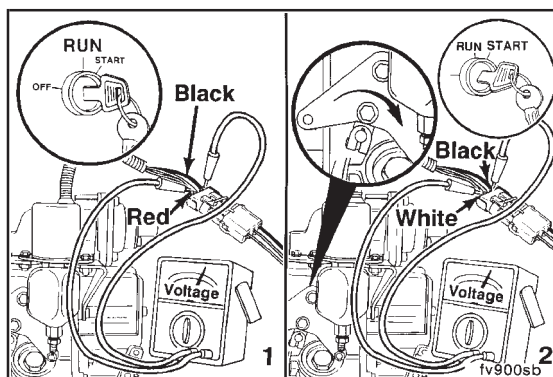

Battery Voltage	Min Voltage	
	Pull-In	Hold-In
12	6.5	4.0
24	13.0	8.0





# Section 6 - Injectors - Group 06

## Section Contents

	Page
<b>Fuel Lines - Clean and Inspect</b> .....	6-16
Fuel Drain Manifold .....	6-17
High Pressure Fuel Lines .....	6-16
Low Pressure Fuel Lines .....	6-18
<b>Fuel Transfer Pump - Cleaning and Inspecting</b> .....	6-13
<b>Fuel Transfer Pump - General Information</b> .....	6-5
<b>Fuel Transfer Pump - Identification</b> .....	6-5
<b>Fuel Transfer Pump - Piston Style Rebuild</b> .....	6-14
Assembly.....	6-15
Cleaning.....	6-15
<b>General Information - Injectors</b> .....	6-4
<b>Injector - Assembly</b> .....	6-10
<b>Injector - Clean and Inspect</b> .....	6-8
<b>Injector - Disassembly</b> .....	6-7
<b>Injector - Service Tools</b> .....	6-2
<b>Injector - Testing</b> .....	6-12
Chatter Test.....	6-13
<b>Injector Group - Exploded View</b> .....	6-3

### Injector - Service Tools

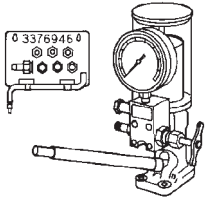
The following special tools are recommended to perform procedures in Group 06. The use of these tools is shown in the appropriate procedure. These tools can be purchased from your local Cummins Authorized Repair Location.

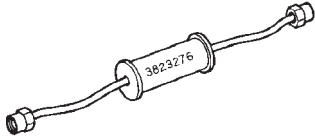
Tool No.	Tool Description	Tool Illustration
3376946	Injector Tester	
3376947	Nozzle Cleaning Kit	
3823276	Flexible Injector Puller	

### Injector Group - Exploded View

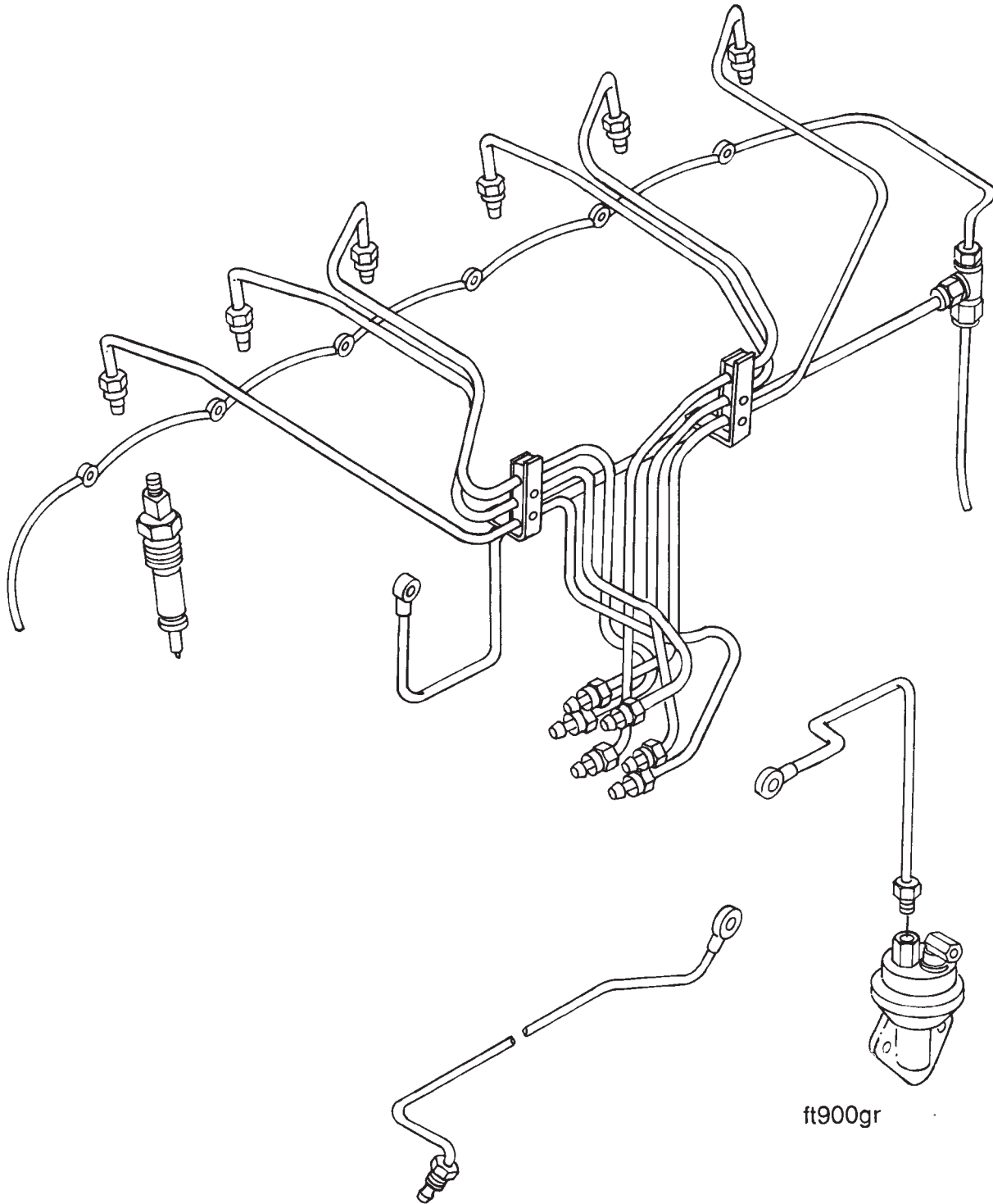

## General Information - Injectors

The injector needle valve and the nozzle tip are machined to a very precise tolerance. Never replace only the needle valve. Never mix the needle valves and nozzle tips, they are matched sets.

This group provides instructions for disassembly, cleaning, assembly and test of the injectors. Also included are cleaning and inspection procedures for the fuel lines, fuel transfer pump, and fuel filter head.



## Fuel Transfer Pump - General Information

### Fuel Transfer Pump - Identification

The B series engine uses three different piston style, and one diaphragm style, transfer pumps. The diaphragm style transfer pump cannot be rebuilt.

Piston style transfer pump, Part No. 3918076, is offered as an option on B series engines equipped with distributor type fuel injection pumps.

**NOTE:** Part No. 3918076 and 3918000 are identical in appearance. The pumping spring free length can be measured to identify the pump.

Fuel transfer pump 3918076 spring free length 53.5 mm [2 7/64 in].

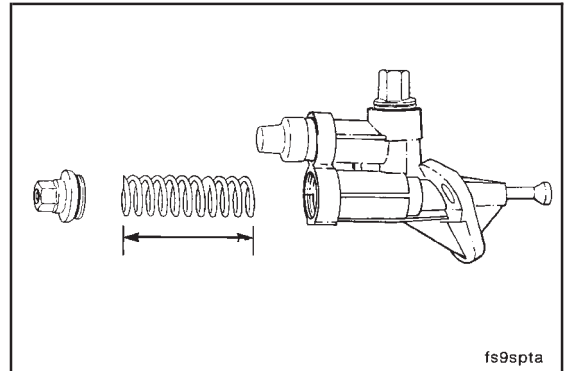

Piston style transfer pump, Part No. 3918000, is used on the 300 HP marine B series engine.

**NOTE:** Part No. 3918076 and 3918000 are identical in appearance. The pumping spring free length can be measured to identify the pump.

Fuel transfer pump 3918000 spring free length 58 mm [2 9/32 in].

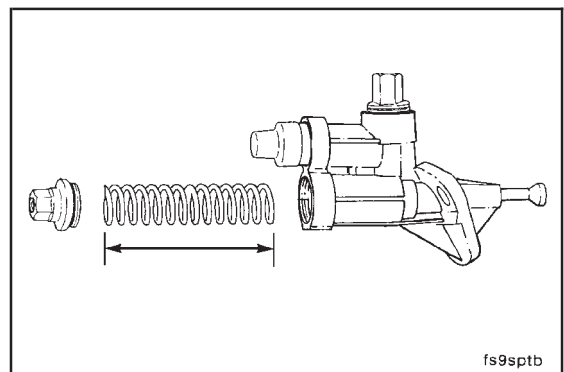

Piston style transfer pump, Part No. 3917334 and 3921550, is used on the 91 B series engine equipped with the Bosch P7100 in-line injection pumps.

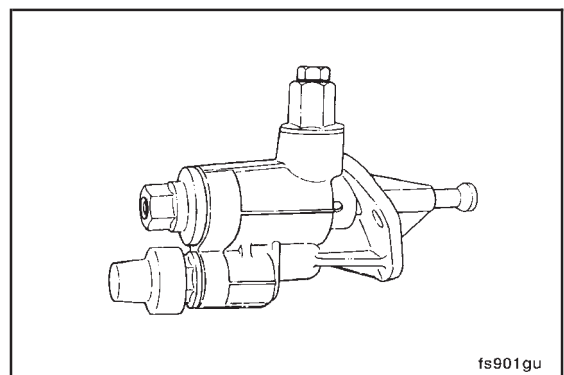

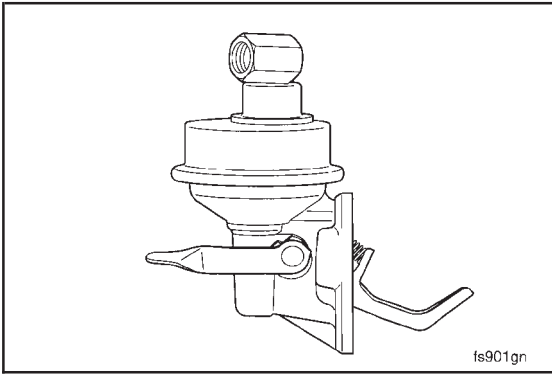

Diaphragm style transfer pump.

### Injector - Disassembly

Clean the carbon residue from the nozzle. Use a brass wire brush and a piece of hardwood dipped in test oil.

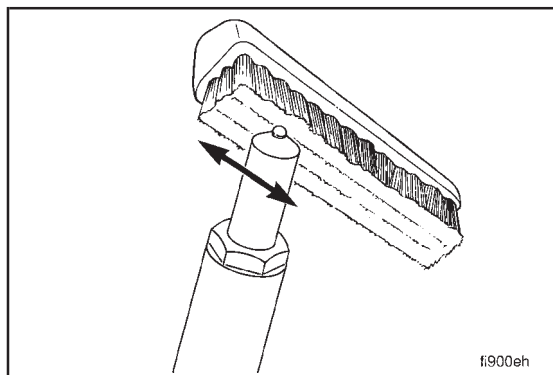

Remove the copper sealing washer and discard.

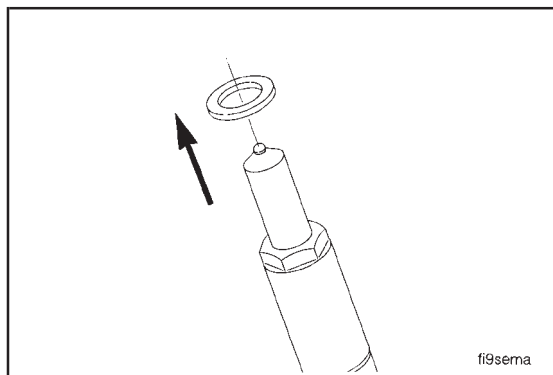

15 mm

Clamp the nozzle holder in a soft jawed vise and remove the nozzle nut.

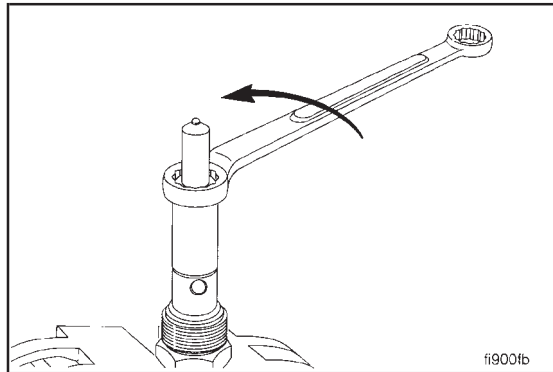

Remove the nozzle needle valve and intermediate plate.

**NOTE:** To avoid damage place injector nozzle and needle valve in a suitable bath of clean test oil.

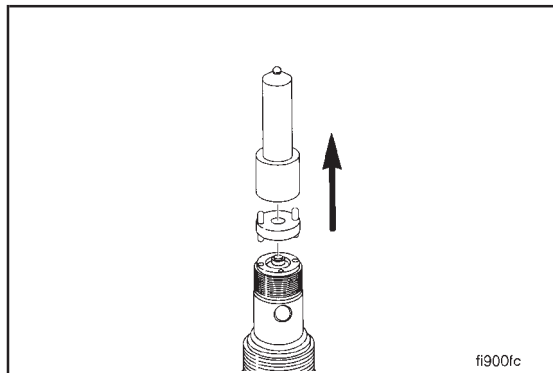

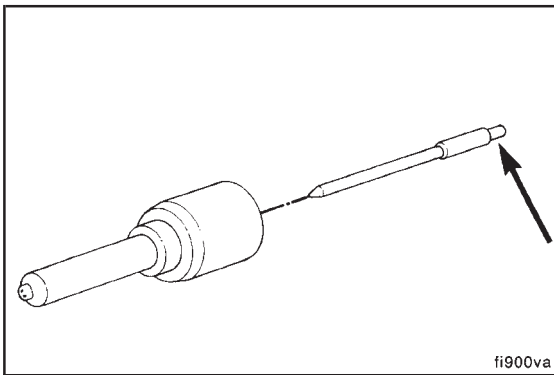

**Caution:** Hold the needle valve by the stem only. Skin oils will corrode the finely lapped surfaces.

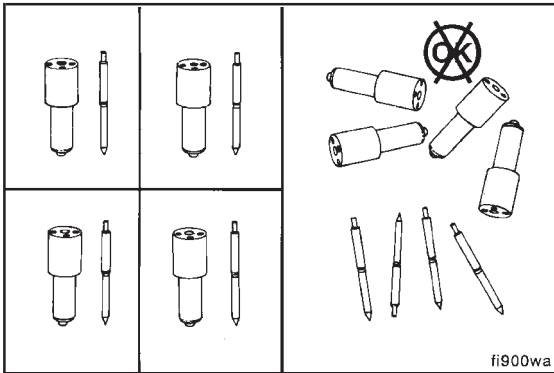

**Caution:** The needle valve and nozzle tip are matched for fit. They must not be intermixed.

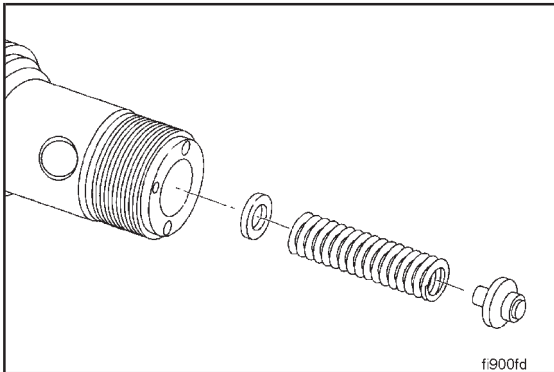

Remove the nozzle holder from the vise; then remove the pressure spindle, pressure spring and shims.

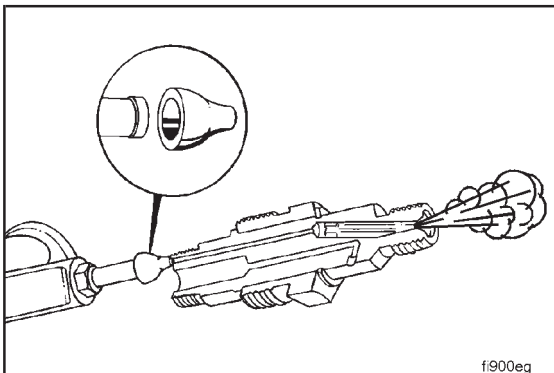

### Injector - Clean and Inspect

Edge-type filters may be cleaned by applying compressed air to the fuel passage from the nozzle side of the nozzle holder. Edge-type filters are not removable for service.

Rinse new nozzle bodies and needle valves in solvent to thoroughly flush and completely remove all protective coating material.

**Nozzle Cleaning Kit 3376947**

**Caution:** Never use emery paper or any other metal scraper to clean the nozzle.

Clean the nozzle seat with scraper as shown dipped in test oil. Polish the needle seat with the piece of hardwood dipped in test oil.

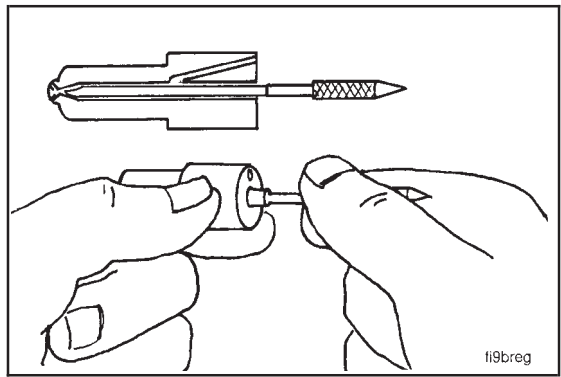

fi9breg

Clean the interior ring groove of the nozzle with the scraper as shown. Rinse in solvent to remove all dirt and carbon residue and dip in clean test oil.

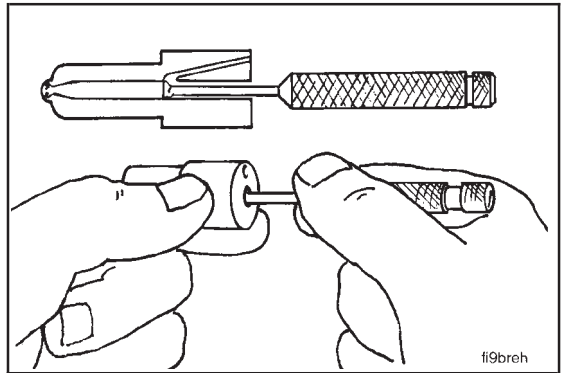

fi9breh

Clean the spray holes of hole type nozzles as shown with the appropriate size cleaning needle.

Remove burned-on combustion deposits on all nozzles with a commercially available cleaner. Rinse all parts in clean test oil.

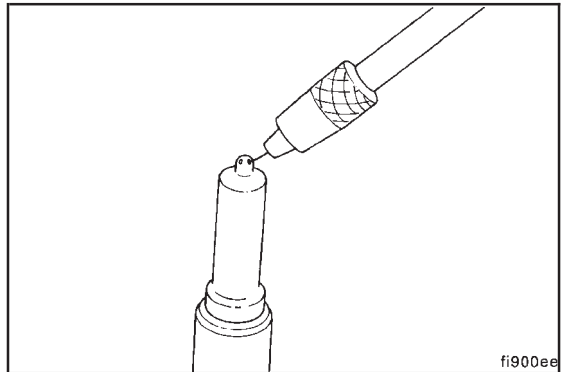

fi900ee

Clean the needle valve tip with a brass brush. Then, inspect for rough surfaces or erosion. The pressure shoulder will normally have a rough machined appearance.

**NOTE:** Deteriorated needle valves must be replaced as a matched unit with their compatible nozzle body.

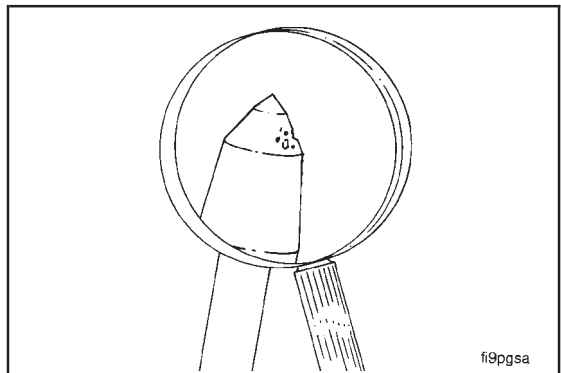

fi9pgsa

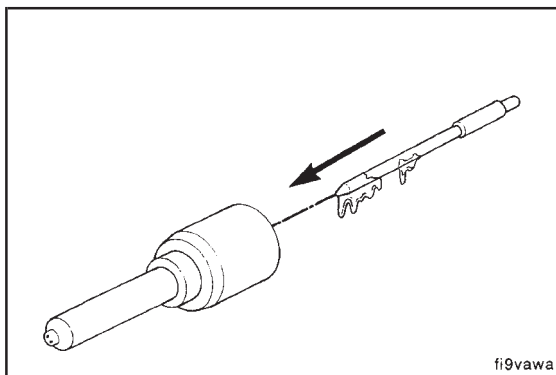

Dip the needle valve in clean test oil and insert the needle valve all the way into the nozzle body.

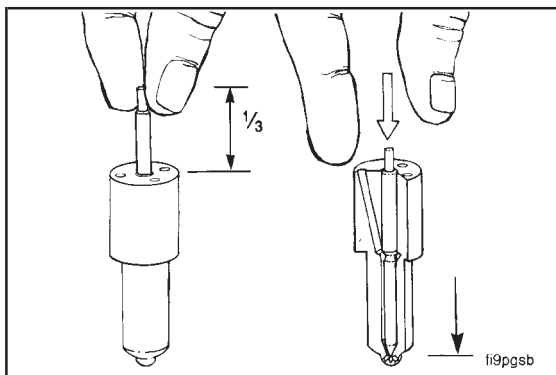

**Caution:** Any needle valve and nozzle body assembly which cannot pass this test must be replaced.



Pull the needle valve one-third of the way out of the nozzle body. The needle valve must slide all the way back into the nozzle body under its own weight.

If the nozzle fails the slide test, clean the nozzle again and retest it.

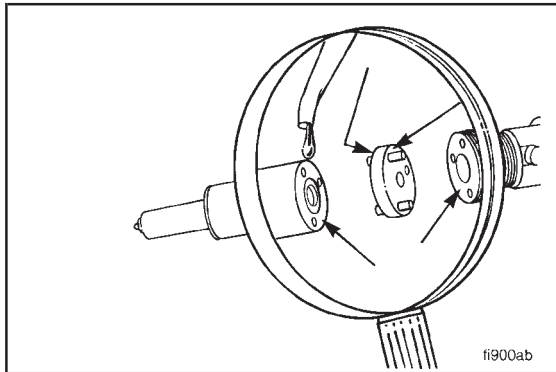

### Injector - Assembly

**NOTE:** Make sure all mating surfaces and pressure faces are absolutely clean and lubricated with fuel oil before assembled.

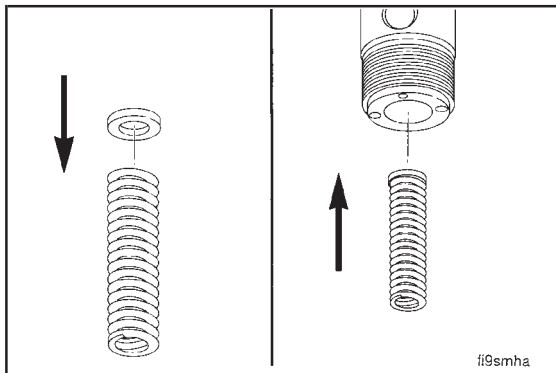

**Caution:** Install the same thickness of shims that were removed in disassembly. Use the pressure spring to make sure the shims are installed flat.



Install the shims.

Clamp the nozzle holder in a soft jawed vise and install the spindle.

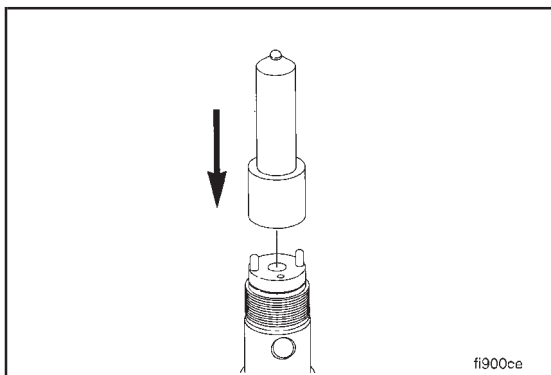

Install the intermediate plate.

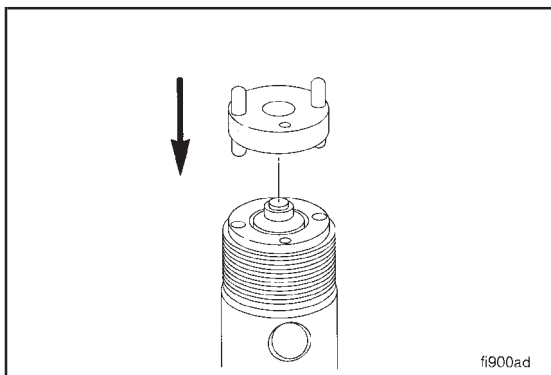

Install the needle valve and nozzle assembly.

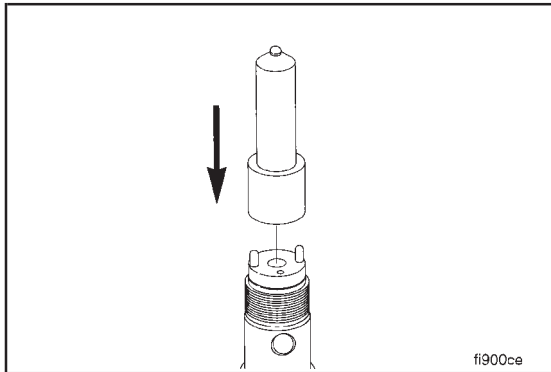

**15 mm**

Install the nozzle nut.

**Torque Value:** 30 N•m [22 ft-lb]

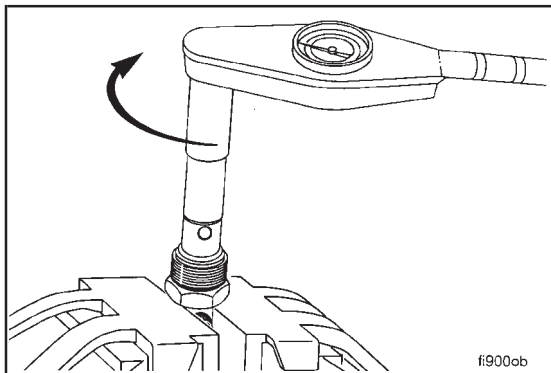

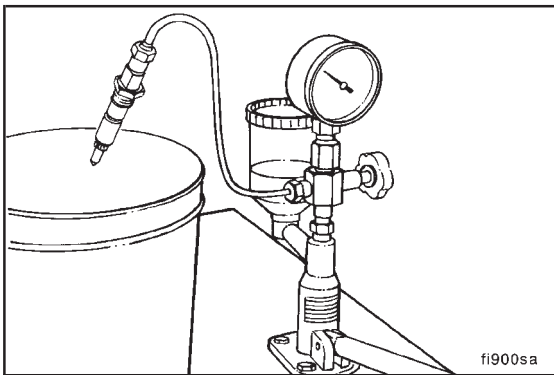

## Injector - Testing



**Warning:** Keep your body clear of test spray. Fluid can be injected into the bloodstream causing blood poisoning and possible death.



All nozzles must be tested for opening pressure, chatter and spray pattern.

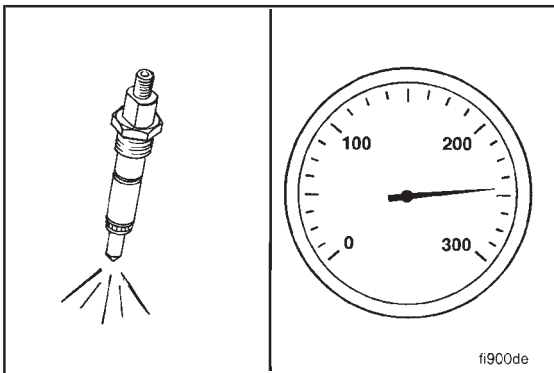

Check the opening pressure.

- a. Open valve.
- b. Operate lever at one stroke per second.
- c. Read pressure indicated when spray begins.

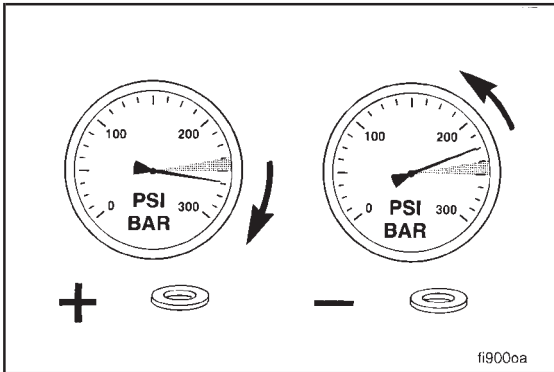

If the opening pressure is out of specification, then change the shim pack. Adding shims will increase pressure.

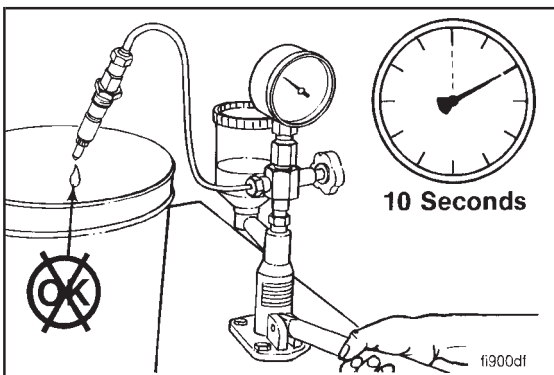

Leakage Test:

- a. Open valve.
- b. Operate lever to hold pressure 20 bar [290 psi] below opening pressure.
- c. No drops should fall from the tip within 10 seconds.



**Chatter Test**

The chatter test indicates the ability of the needle valve to move freely and correctly atomize the fuel. You should hear the valve open and should see a well atomized spray pattern.

Used nozzles should not be evaluated for chatter at lower speeds. A used nozzle can generally be used if it passes the leakage test, chatters audibly at high lever speeds and uniformly atomizes the fuel.

**Fuel Transfer Pump - Cleaning and Inspecting**

Visually inspect the fuel transfer pump for obvious cracks or damage that would prohibit reuse. Inspect the weep hole area for signs of fuel leakage.

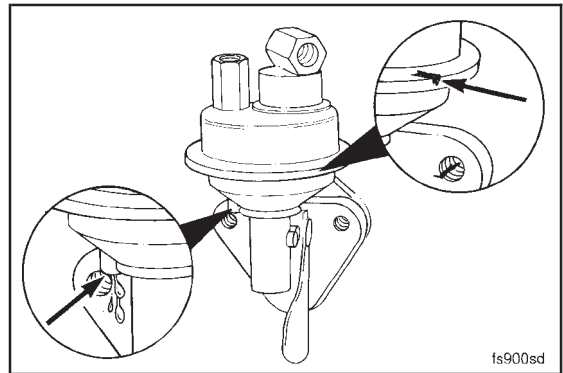

Clean the pump in mineral spirits. Blow dry with compressed air.

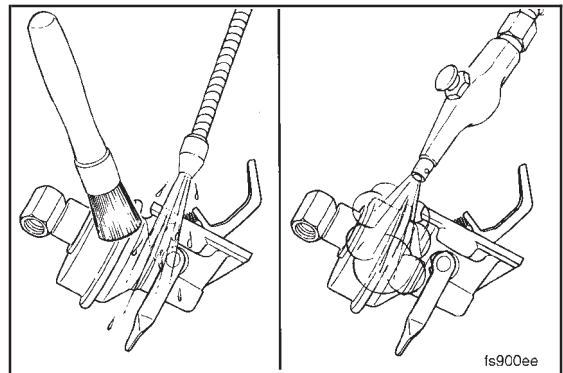

Inspect the camshaft lever and the return spring for excessive wear.

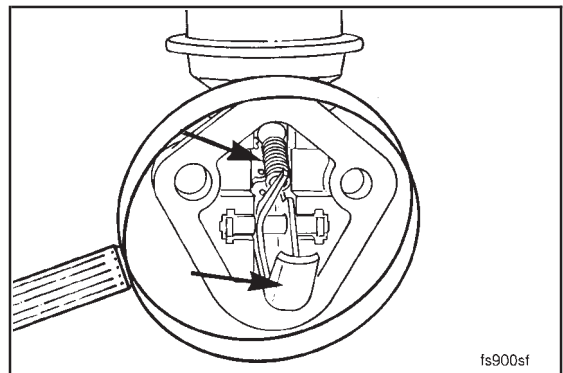

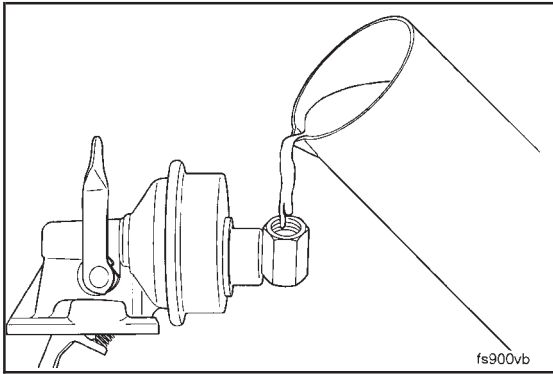

To inspect the transfer pump, pour clean diesel fuel or engine oil into the inlet connection and perform the following test:

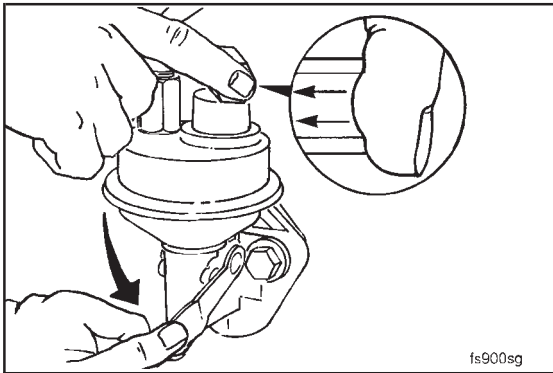

Inspect the diaphragm by blocking the fuel inlet line with your finger and operating the priming lever.

A good pump will have suction that will not bleed down until the finger is removed from the inlet.

On diaphragm style fuel transfer pumps, parts replacement is not practical; the pump is serviced as an assembly. An optional piston style pump is available which can be cleaned and repaired with a minor repair kit.

## Fuel Transfer Pump - Piston Style Rebuild

Preparatory Step:

- Clean debris from the fuel line fittings and the fuel transfer pump.

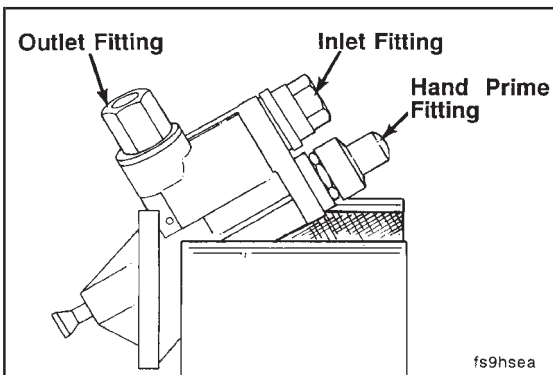

20 mm, 26 mm Wrench



**Caution:** The hand-prime fitting and inlet fitting are spring loaded. Sudden removal of these two fittings can cause personal injury.



Secure the pump in a vise, taking care not to damage the pump housing.

Remove the rubber boot from the hand-prime fitting.

Remove the three illustrated fittings.

Remove all internal components of the pump.

**NOTE:** Make sure the check valve gaskets are removed from the inlet fitting.

- (A) Outlet Fitting
- (B) Inlet Fitting
- (C) Hand Primer Fitting

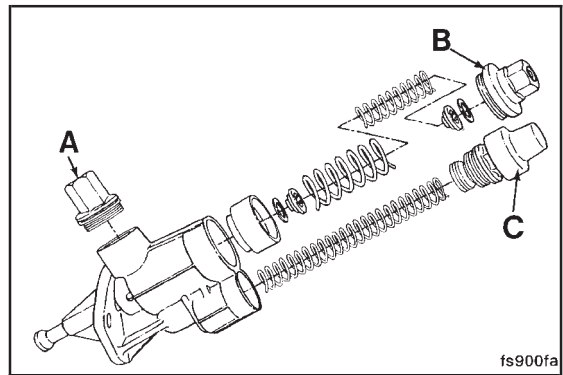

### Cleaning

Thoroughly flush the pump with a cleaning solution to remove any debris.

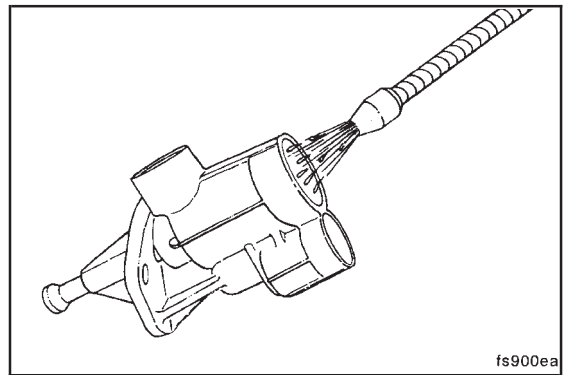

### Assembly

#### 20 mm, 26 mm Wrench

Assemble the pump with the new components supplied in the rebuild kit.

1. Check valves
2. Check valve gaskets
3. O-ring seal
4. Outlet fitting/check valve
5. \*O-ring seal (25 mm)
6. \*O-ring seal (30 mm) or (25 mm)

\* O-ring required is determined by the size of the inlet fitting. Discard unused o-ring.

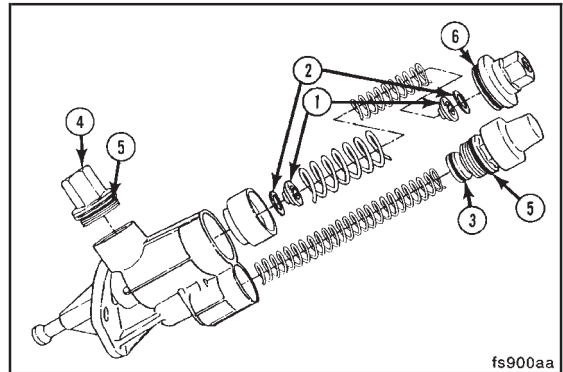

**NOTE:** Extreme caution must be used to make sure the check valves are installed to open in the direction of the fuel flow.

Improper installation of the check valves will result in low power from the engine.

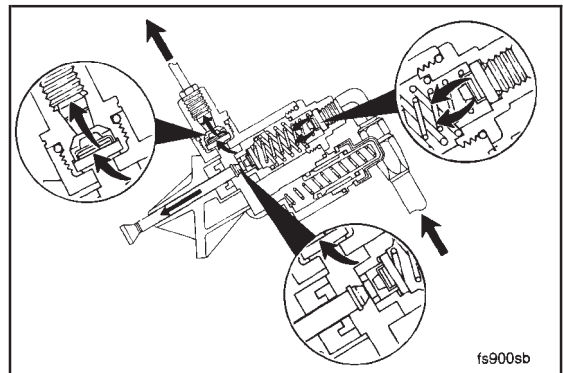

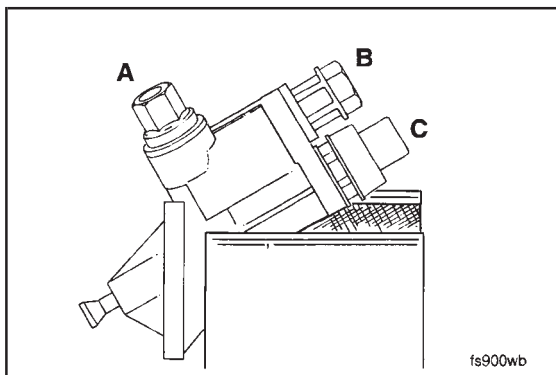

Place the pump in a vise and torque the fittings to the following values:

- |                        |        |            |
|------------------------|--------|------------|
| (A) Outlet Fitting     | 30 N•m | [22 ft-lb] |
| (B) Hand-Prime Fitting | 30 N•m | [22 ft-lb] |
| (C) Inlet Fitting      | 30 N•m | [22 ft-lb] |

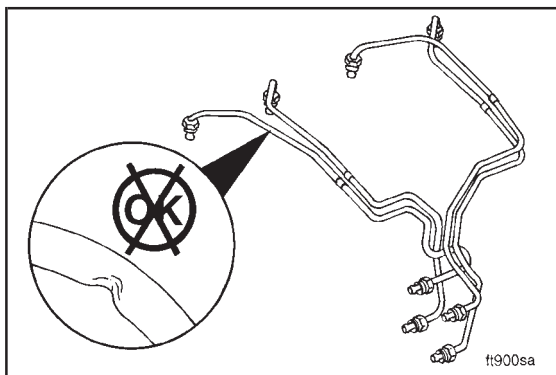

### Fuel Lines - Clean and Inspect High Pressure Fuel Lines

Visually inspect the high pressure fuel lines for obvious damage such as lines that have bent to facilitate injector removal. High pressure pulses expand and contract the injector lines which result in internal flaking at the bent areas. Bent lines should be replaced.

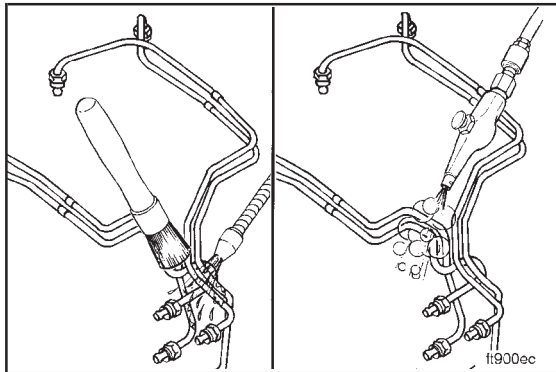

Wash the fuel lines in clean solvent and blow dry with compressed air. Make sure all paint chips are removed.

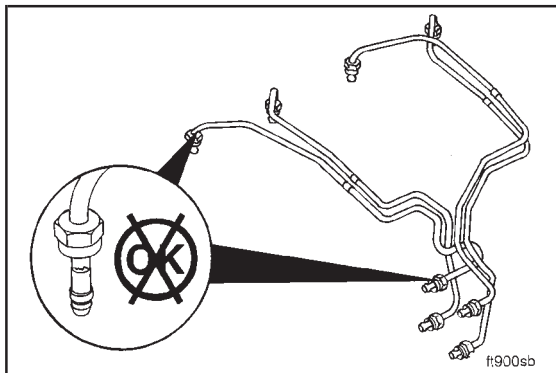

Visually inspect for cracks at both ends of the fuel lines.

**Caution:** The high pressure lines must be clamped securely and routed so they do not contact each other or any other component. Inspect for areas of contact that have worn the material thin.

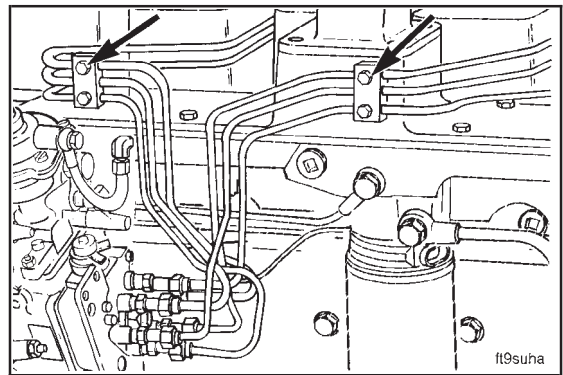

Inspect the vibration isolators (clamps). Make sure all the vibration isolators are positioned and tightened properly. Missing or improperly installed isolators will almost certainly result in fuel line failure.

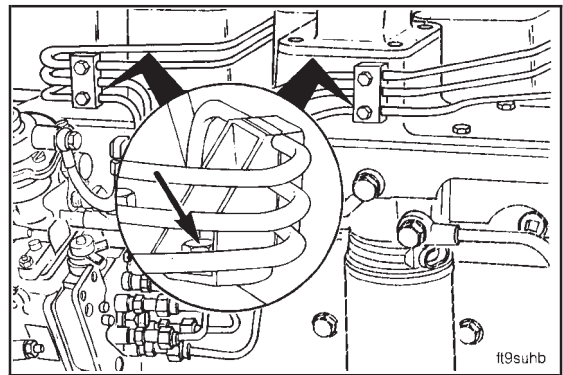

**Caution:** Do not weld or substitute lines; use only the specified part number for the engine.



The length, internal size and rigidity of the lines is critical to smooth engine operation. An attached metal tag is used to identify each line with a part number.

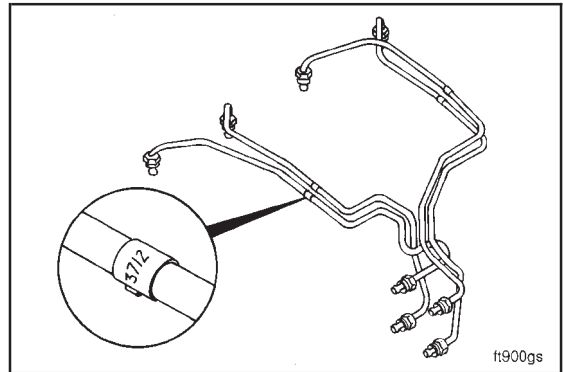

**Fuel Drain Manifold**

Inspect the fuel drain manifold for cracks and obvious damage.

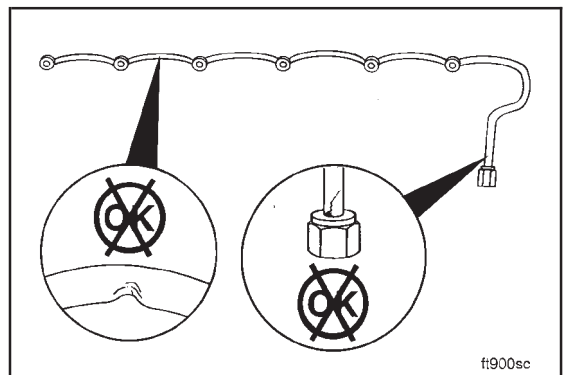

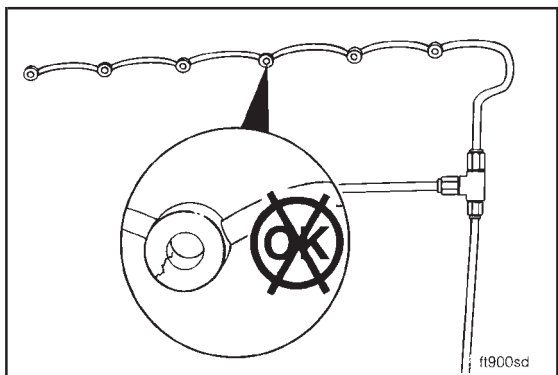

Inspect the sealing surfaces for leak paths.

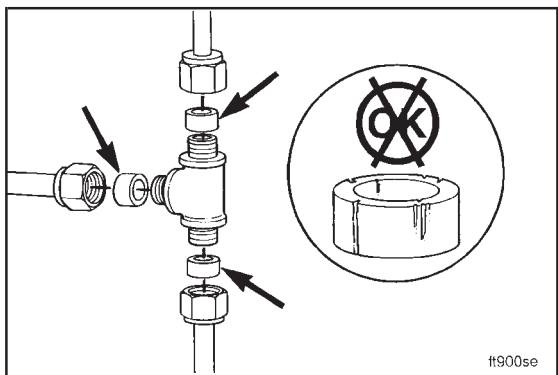

13 mm



Inspect the rubber seals. Replace any damaged seals or seals that are hard or brittle.



Service Tip: Lubricating the seals with clean engine oil will facilitate the installation.

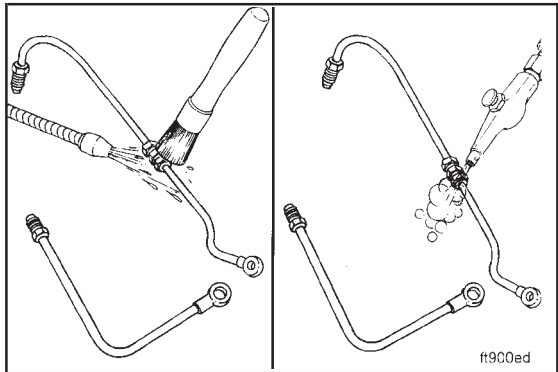

**Low Pressure Fuel Lines**

Wash the low pressure fuel lines in clean solvent. Blow dry with compressed air.

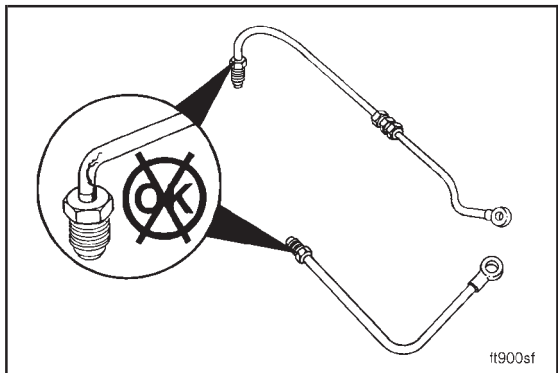

Visually inspect the lines for obvious damage such as cracks or worn areas.

**17 mm, 16 mm**

Inspect the rubber seals. Replace any damaged, hard, or brittle seals.

Service Tip: Lubricating the seals with clean engine oil will facilitate the installation.

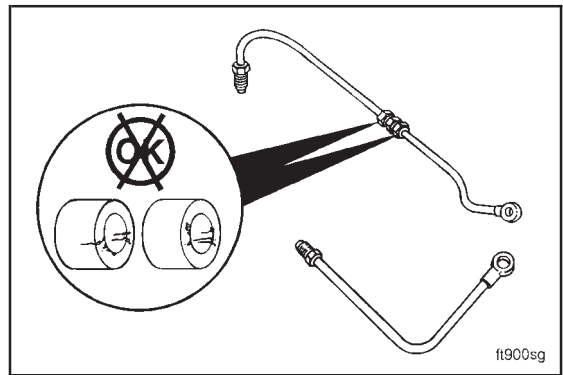

## Section 7 - Lubrication Oil System - Group 7

### Section Contents

	<b>Page</b>
<b>Filter Bypass Valve - Replace</b> .....	7-8
<b>General Information - Lubrication System</b> .....	7-6
Oil Cooler Core .....	7-6
Oil Filter Head/Pressure Regulator Plunger.....	7-6
<b>Lubricating Oil Cooler - Exploded View</b> .....	7-5
<b>Lubricating Oil Pump - Exploded View</b> .....	7-10
<b>Lubrication Oil Pump - General Information</b> .....	7-11
<b>Oil Cooler - Cleaning</b> .....	7-8
<b>Oil Cooler - Inspection</b> .....	7-9
<b>Oil Pan and Suction Tube - Cleaning and Inspection</b> .....	7-4
<b>Oil Pan and Suction Tube - Exploded View</b> .....	7-2
<b>Oil Pan and Suction Tube - General Information</b> .....	7-3
<b>Oil Pump - Inspection</b> .....	7-12
<b>Pressure Regulator Valve - Assembly</b> .....	7-8
<b>Pressure Regulator Valve - Disassembly</b> .....	7-7
<b>Pressure Regulator Valve - Inspection</b> .....	7-7



Oil Pan and Suction Tube - Exploded View

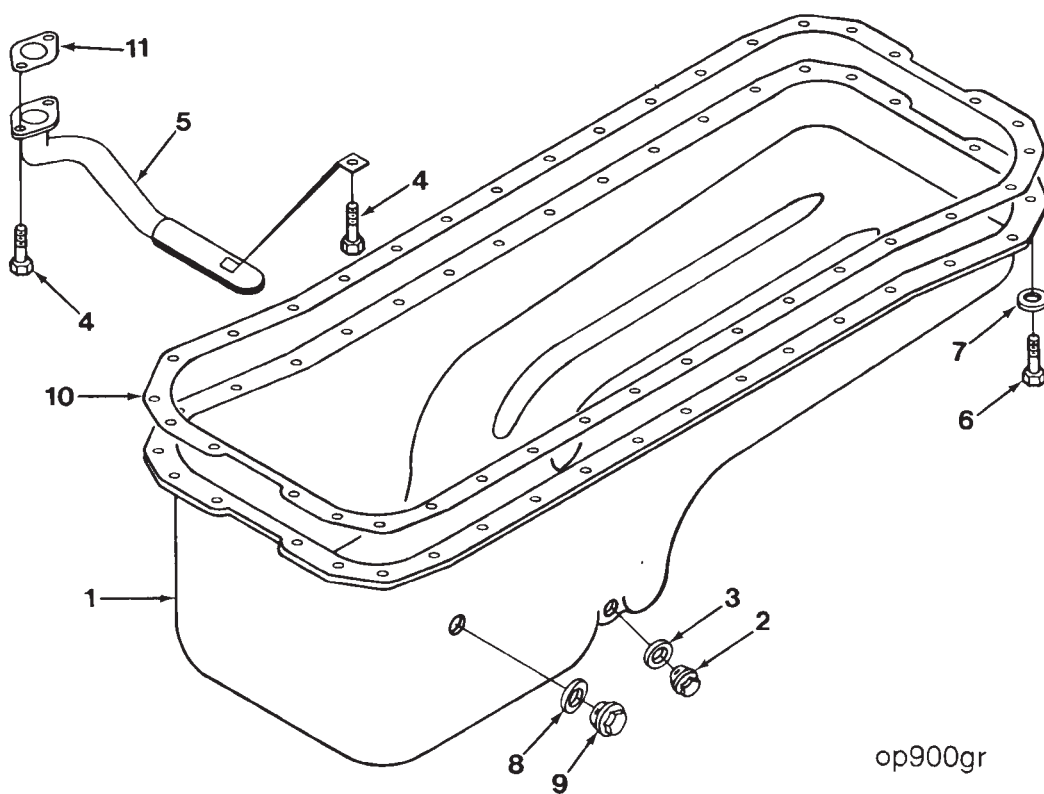

Ref. No.	Part Name	Qty.	Remarks
1	Pan, Oil	1	
2	Plug, Threaded	1	M18 - 1.5 x 12mm
3	Washer, Sealing	1	1.5mm thick, 18.40 I.D.
4	Screw, Hexagon Head Cap	3	M8 - 1.25 x 16mm
5	Connection, Oil Suction	1	
6	Screw, Hexagon Head Cap	36	M8 - 1.25 x 20mm
7	Washer, Spring	36	
8	Washer, Sealing	1	22.2 I.D. x 1.5mm thick
9	Plug, Threaded	1	M22 x 1.5 mm
10	Gasket, Oil Pan	1	
11	Gasket, Flange	1	

## Oil Pan and Suction Tube - General Information

The B Series engine is available with various oil pan/suction tube configurations based on the customer's needs; i.e., oil capacity, angularity limits, drain plug location, etc. However, all the oil pans fall into two basic types, center sump and front or rear sump. Both types of oil pans can be rotated front to back to meet various installation requirements such as moving a drain plug to a specific side or front and rear sump requirements.

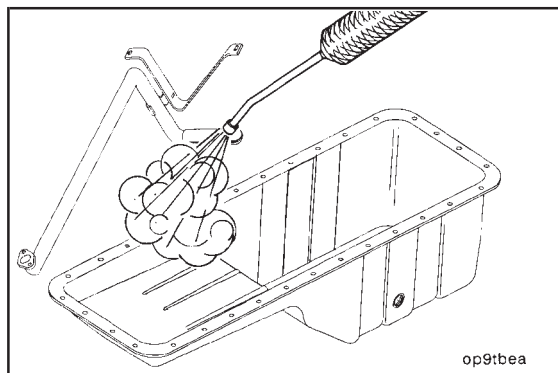

### Oil Pan and Suction Tube - Cleaning and Inspection (7-01)

Steam clean the pan and suction tube.

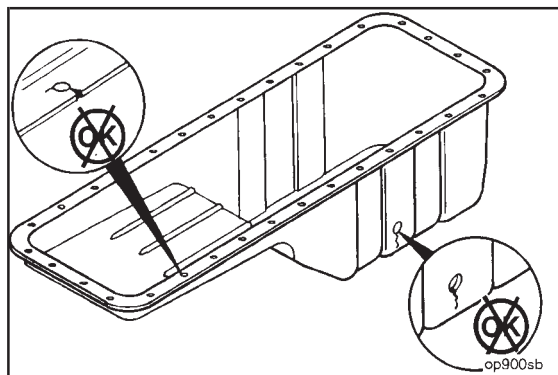

Inspect the pan for cracks and damaged threads.

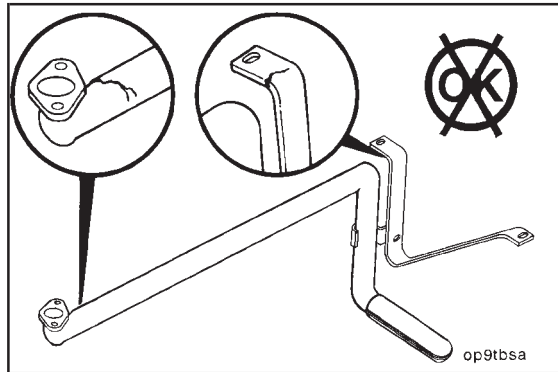

Inspect the oil suction tube and brace for cracks. Do not reuse a cracked oil suction tube or brace.

Also check the block mounting surface for damage.

### Lubricating Oil Cooler - Exploded View

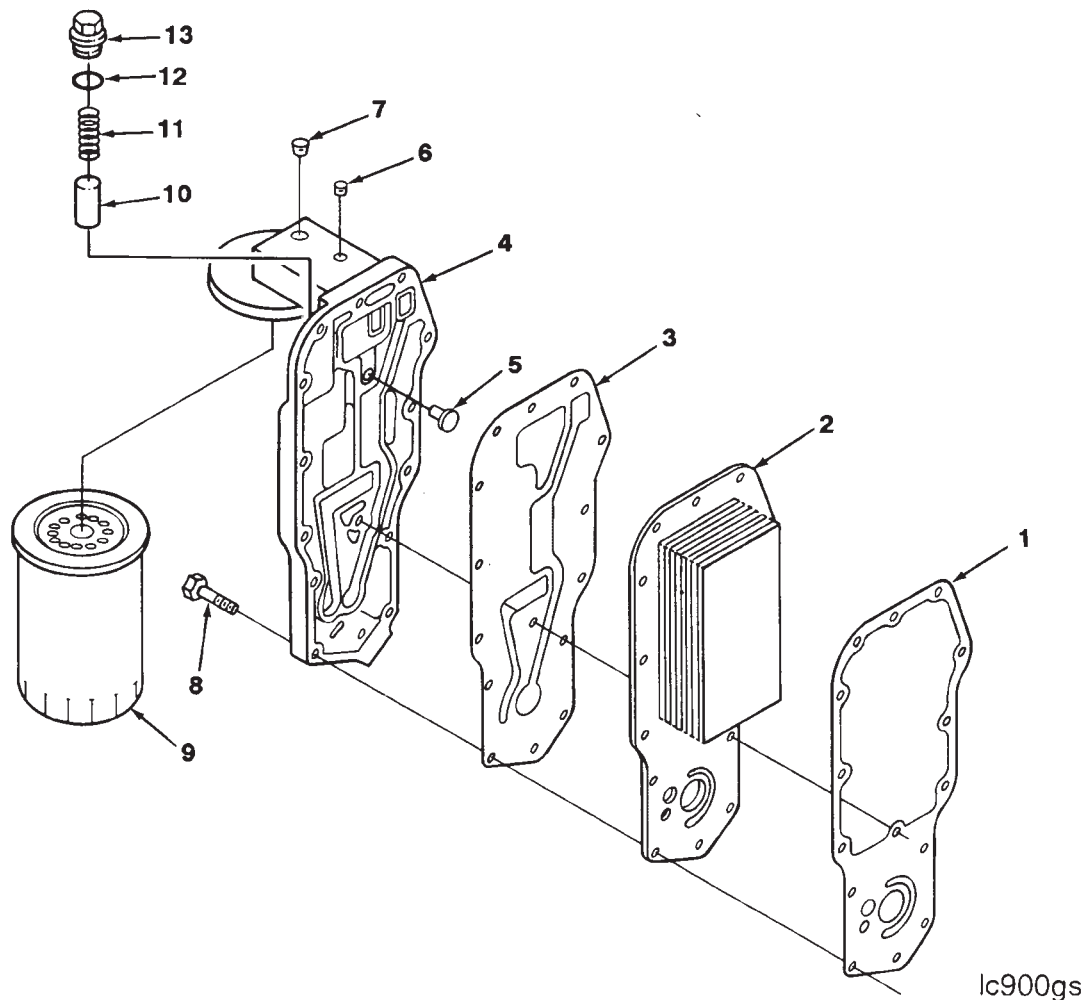

Ref. No.	Part Name	Qty.	Remarks
1	Screw, Hex Flange Head Cap	14	M8 x 1.25 x 35
2	Valve, Bypass	1	
3	Spring, Compression	1	
4	Plug, Pipe	1	1/8 NPT
5	Head, Lub Oil Filter	1	
6	Adapter, Filter Head (Not Replaceable)	1	
7	Core, Cooler	1	
8	Gasket, Filter Head	1	
9	Plug, Threaded	1	M22 x 1.50
10	Seal, O Ring	1	
11	Plunger, Prs Regulator	1	
12	Gasket, Oil Cooler Core	1	
13	Cartridge, Lub Oil Filter	1	

## General Information - Lubrication System

### Oil Cooler Core

The B Series engine uses a full flow, plate type oil cooler. The oil flows through the element where it is cooled by engine coolant flowing past the plates of the element.

The four cylinder engine uses five plates. The six cylinder engine uses seven plates.

**NOTE:** Some engines use a jumper plate in place of an oil cooler.

### Pressure Regulator Valve - Disassembly (7-02)

19 mm

Remove the plug and sealing washer.

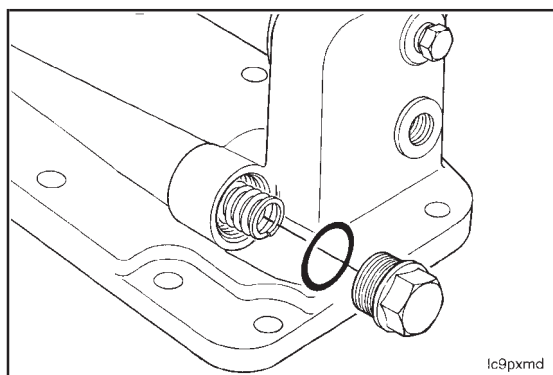

Remove the spring and plunger.

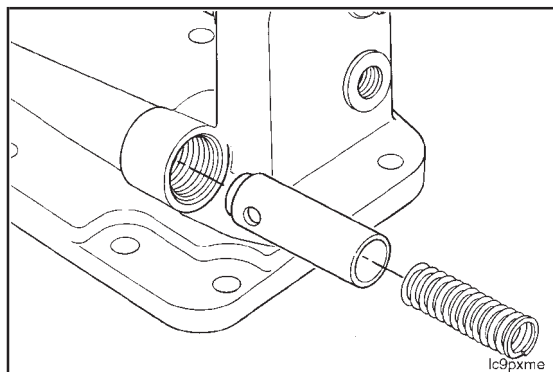

### Pressure Regulator Valve - Inspection (7-03)

Inspect the plunger bore for nicks or scratches.

The plunger must move freely in the bore.

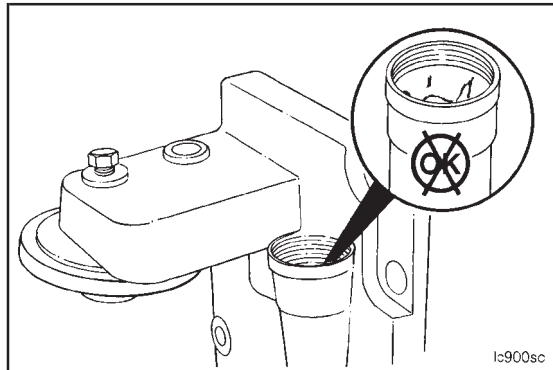

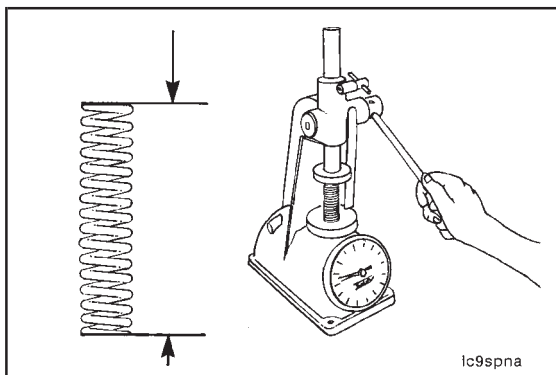

Check the pressure regulator spring at the following two heights.

**Free Length 60.6 mm [2.38 in]  
Limit  
1991**

- 44.5 mm [1.752 in] - Min. Load 105 N [23.6 lb] (regulator valve opens)
- 41.25 mm [1.624 in] - Min. Load 142 N [32 lb] (regulator valve seated)

**Free Length 66 mm [2.59 in]  
(1994)**

- 44.5 mm [1.752 in] - Min. Load 116 N [26.1 lbf] (regulator valve opens)
- 41.25 mm [1.624 in] - Min. load 137 N [30.8 lbf] (regulator valve seated).

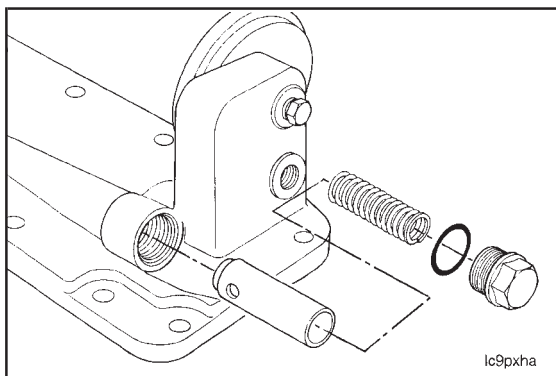

**Pressure Regulator Valve - Assembly  
(7-04)**

19 mm



Install the valve.



**Torque Value: 80 N•m [59 ft-lb]**

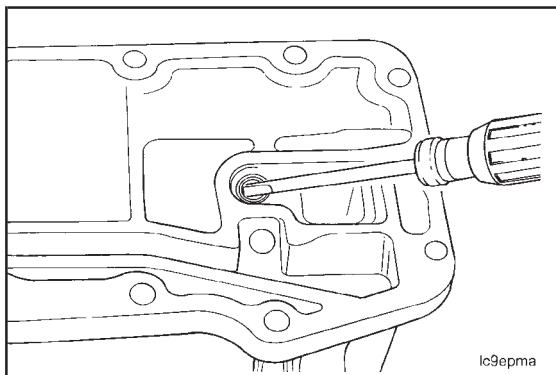

**Filter Bypass Valve - Replace (7-05)**

Remove the valve from the cooler cover.

Drive the new valve in until it bottoms against the step in the bore.

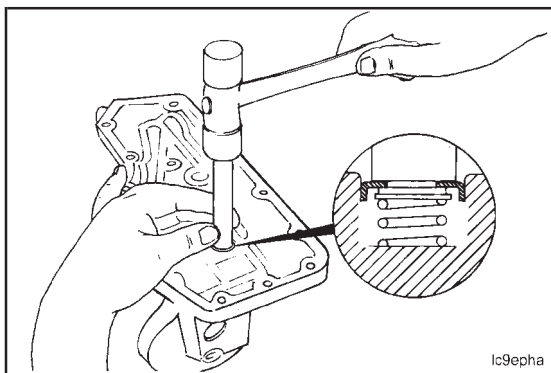

### Oil Cooler - Cleaning (7-06)

Plug the cooler and soak it in a cleaning solution to remove the coolant deposits.

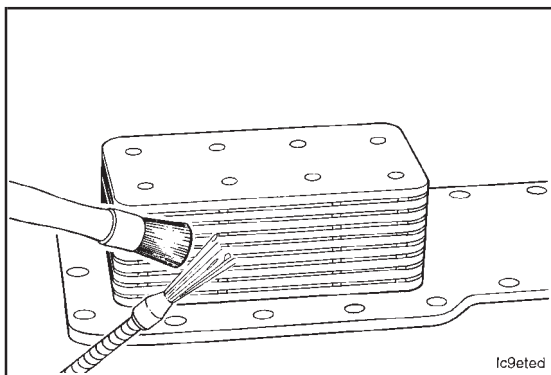

Remove the plugs and soak the cooler in solvent.

The cooler can be cleaned in a hot tank.

Back flush the oil passages with clean solvent and use compressed air to dry.

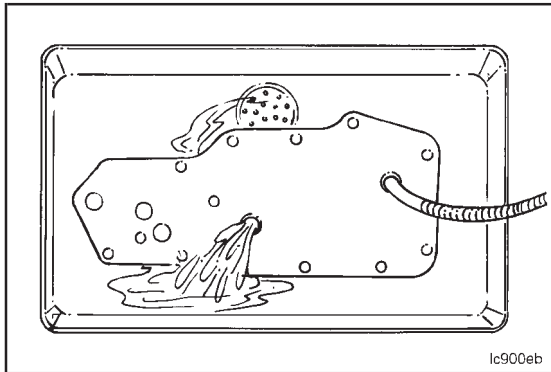

### Oil Cooler - Inspection (7-07)

Inspect the soldered joints for corrosion or cracks.

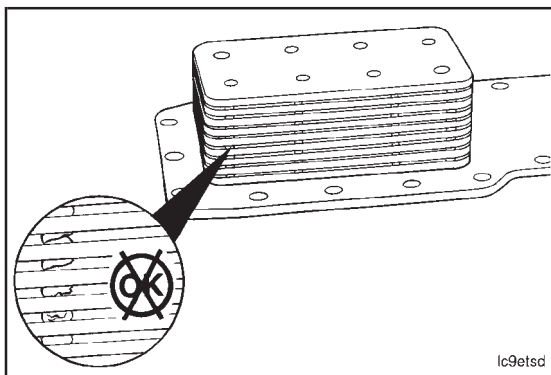



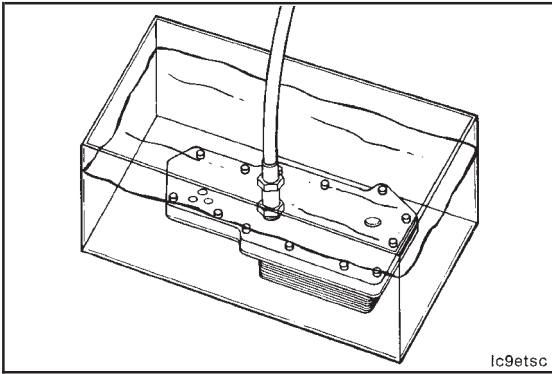

Pressurize the cooler to 483 kPa [70 psi] and check for leaks by submerging in water.

Lubricating Oil Pump - Exploded View

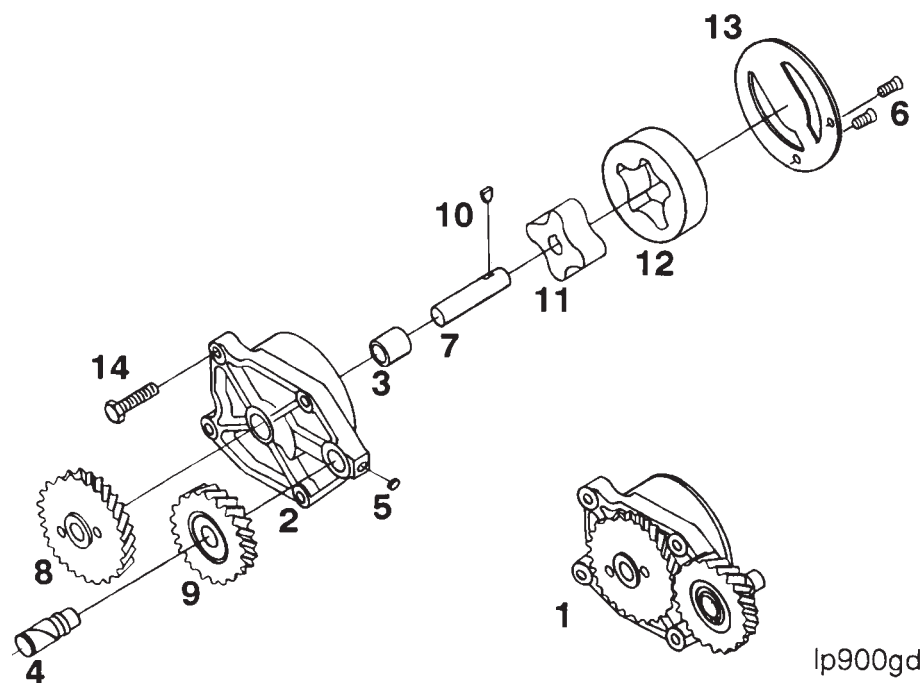

Ref. No.	Part Name	Qty.	Remarks
1	Pump, Lube	1	(Note 1)
2	Body, Lube Pump	1	
3	Bearing, Sleeve	1	
4	Shaft, Lube Pump Idler	1	
5	Plug, Oil Rifle	1	
6	Screws	2	
7	Shaft, Lube Pump	1	
8	Gear, Lube Pump Drive	2	
9	Gear, Lube Pump Idler	1	
10	Key, Woodruff	1	
11	Gerotor, Driver	1	
12	Gerotor, Planetary	1	
13	Plate, Lube Pump Back	1	
14	Screw, Hex Hd Cap	4	M8-1.25x30

Note 1: Item 1 is available as an assembly only. Exploded view is shown for information purposes.

## Lubrication Oil Pump - General Information

It is not practical to rebuild the gerotor pump. It can be reused if it meets the inspection criteria.

There are two basic B Series lubrication pumps - one for the four cylinder and one for the six cylinder.

The gerotor width on the four cylinder pumps is narrower than in the six cylinder pumps.

### Oil Pump - Inspection (7-08)

Visually inspect the lube pump gears for chips, cracks, or excessive wear.

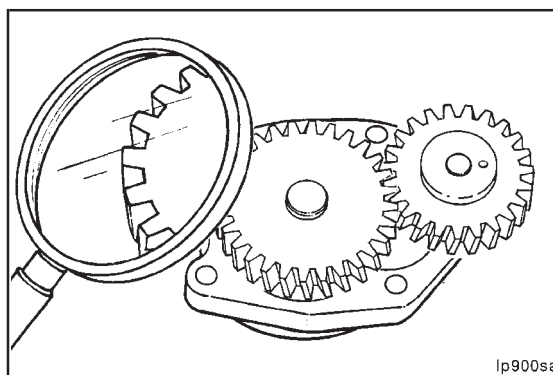

Remove the sealing plate.

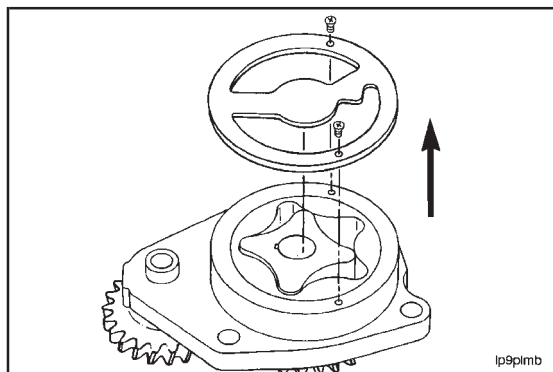

Mark "top" on the gerotor planetary.

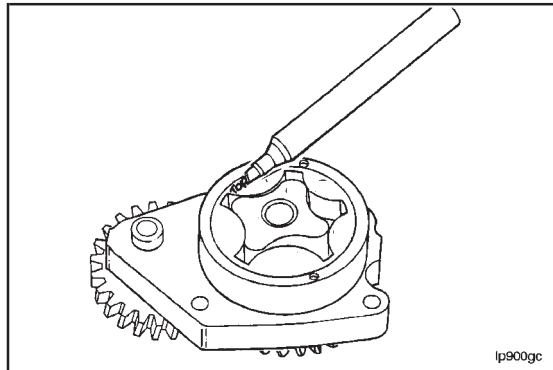

Remove the gerotor planetary.  
Inspect for excessive wear or scoring.

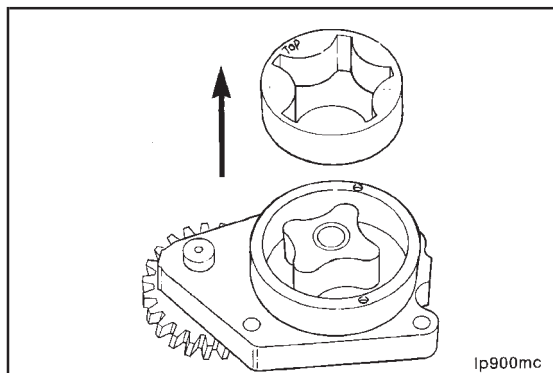

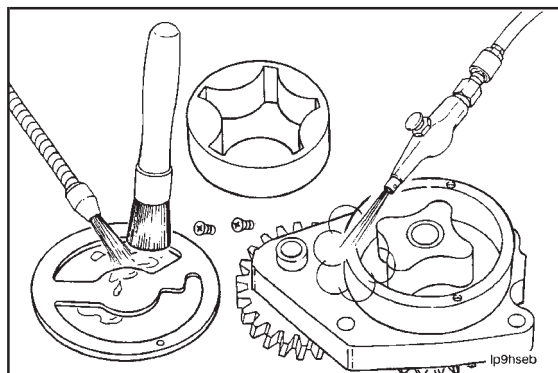

Clean all parts in solvent and use compressed air to dry.

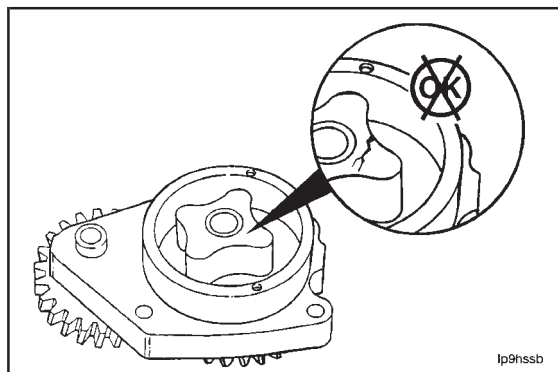

Inspect the pump housing and gerotor drive for damage and excessive wear.

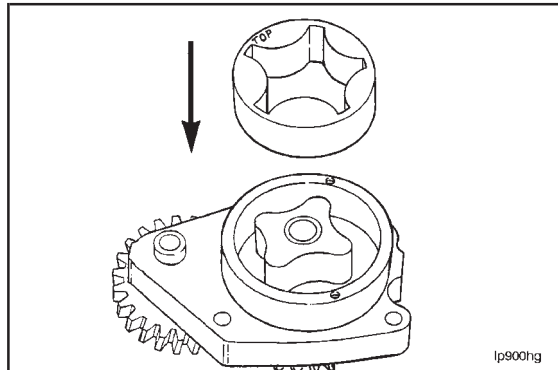

**Be sure the gerotor planetary is installed in the original position.**

Install the gerotor planetary.

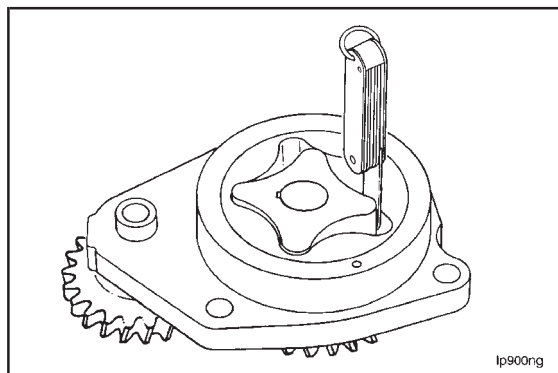

Measure the tip clearance.

Tip Clearance		
mm		in
0.1778	MAX	[0.007]

Measure the clearance of the gerotor drive/gerotor planetary to port plate.



Port Plate Clearance		
mm		in
0.127	MAX	[0.005]

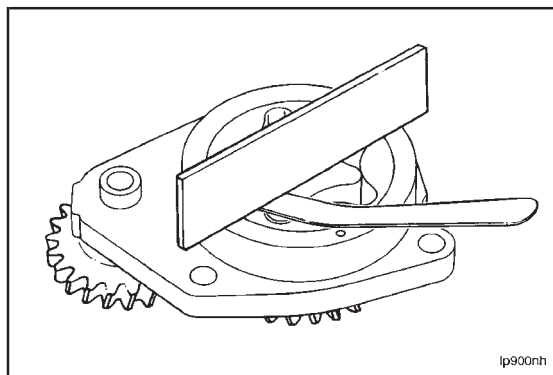

Measure the clearance of the gerotor planetary to the body bore.



Body Bore Clearance		
mm		in
0.381	MAX	[0.015]

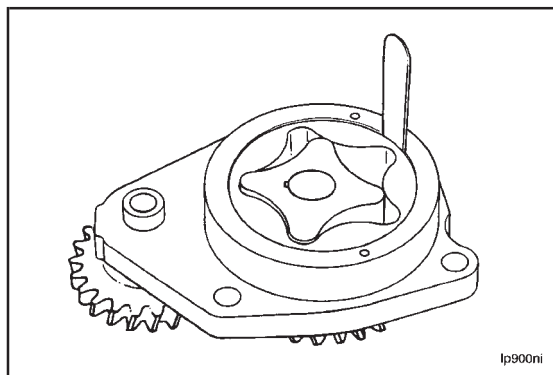

Measure the gears backlash.



Limits for a "Used Pump"
0.076 - 0.33 mm [0.003 - 0.013 in]

**NOTE:** Prevent movement of the adjoining gear when checking backlash or the reading will be the total of both gears.

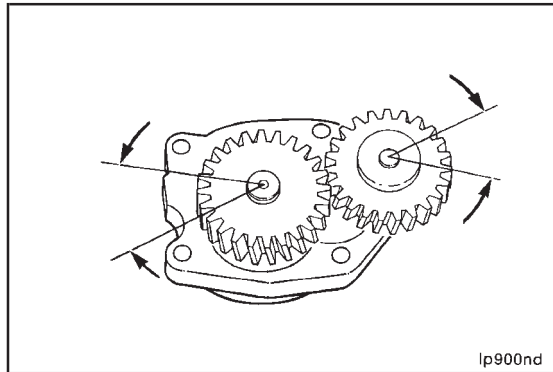

Install the lube pump back plate.

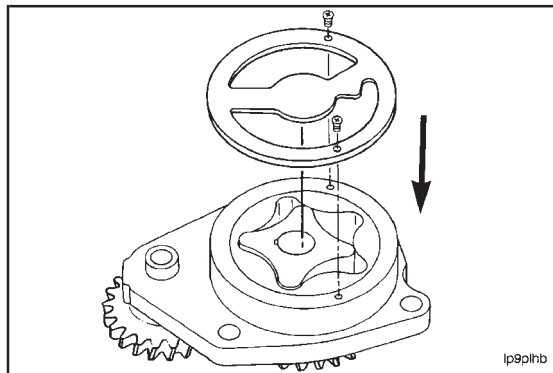



## Section 8 - Cooling System - Group 8

### Section Contents

	Page
Belt Tensioner - Inspection .....	8-10
Belt Tensioner and Fan Hub - Exploded View .....	8-5
Belt Tensioner and Fan Hub - General Information .....	8-6
Belt Tensioner .....	8-6
Fan Hub - Disassembly .....	8-7
Fan Hub - Inspection .....	8-7
Fan Hub Assembly .....	8-8
General Information About Fans .....	8-14
Thermostat - Inspection .....	8-13
Thermostat Housing Assembly - Exploded View .....	8-11
Thermostat Housing Assembly - General Information .....	8-12
Water Pump - Exploded View .....	8-2
Water Pump - General Information .....	8-3
Water Pump - Inspection .....	8-4



**Water Pump - Exploded View**

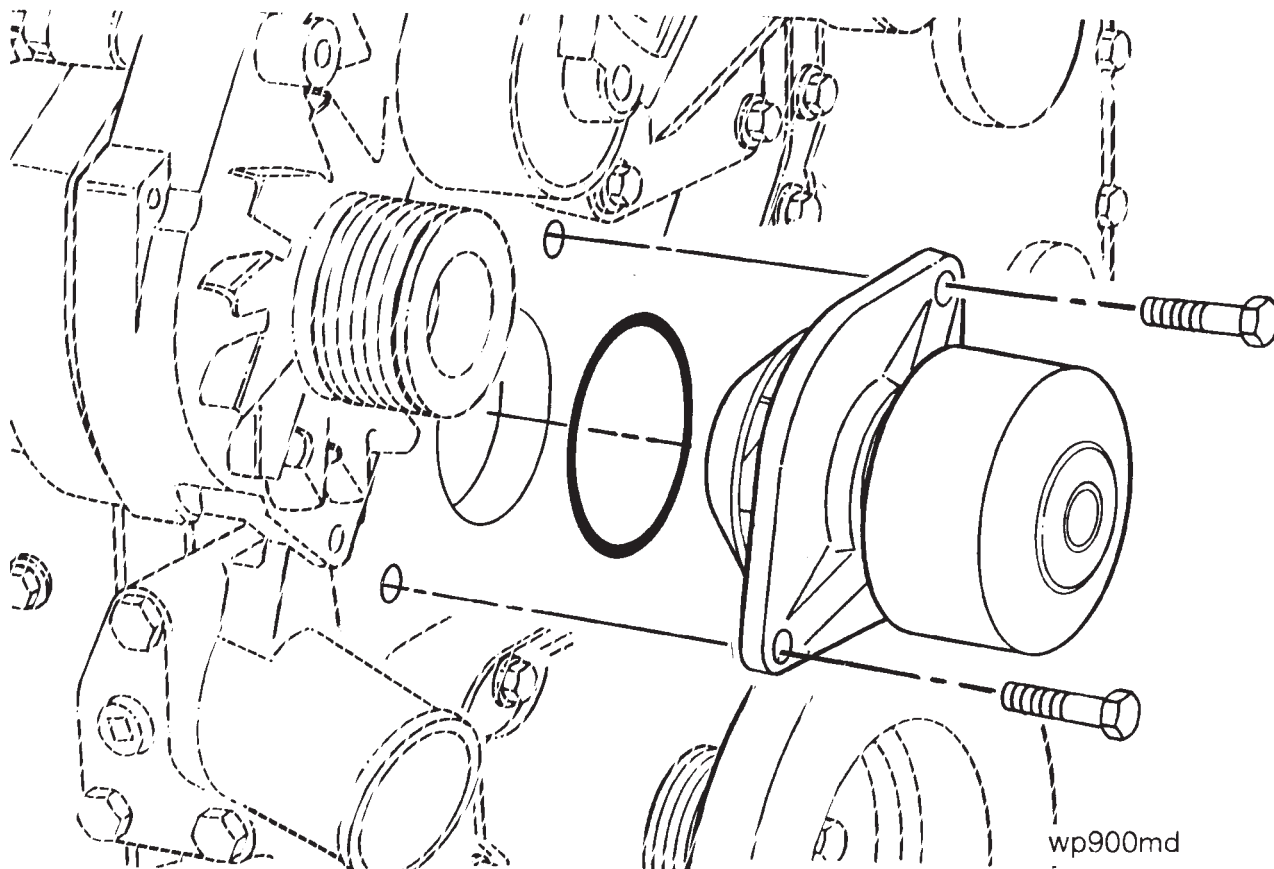

Ref. No.	Part Name	Qty.	Remarks
1	Pump, Water	1	
2	Seal, Rectangular Ring	1	5.16 mm Thick
3	Screw, Hex Hd Cap	2	M8-1.25x22

## Water Pump - General Information

The water pump is a belt driven, centrifugal type pump with the inlet and bypass line as an integral part of the cylinder block.

It is not practical to replace the parts in the pump, the water pump is serviced as an assembly. ReCon® water pumps are available from Cummins Distributors and Dealers.

### Water Pump - Inspection (8-01)

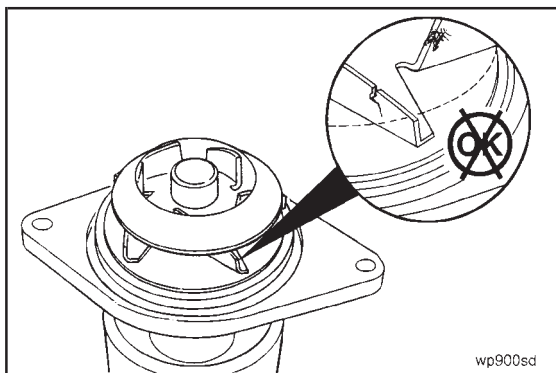

Inspect the impeller blades for wear or corrosion.

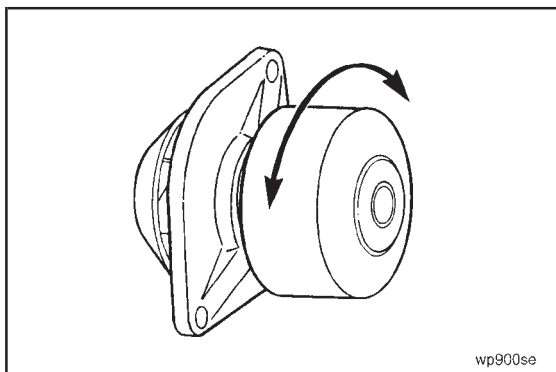

Inspect for free rotation of the pump.

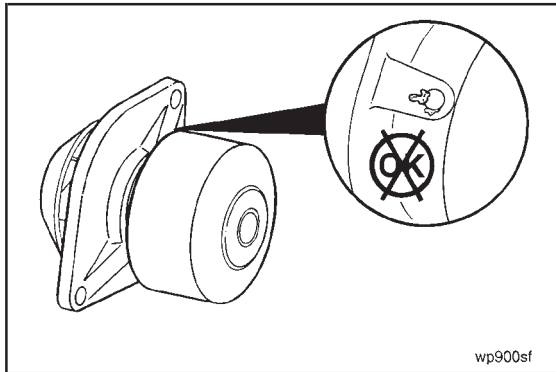

Check the weep hole for evidence that the seal has been leaking.

**Parts replacement is not practical: the water pump is serviced as an assembly.**

### Belt Tensioner and Fan Hub - Exploded View

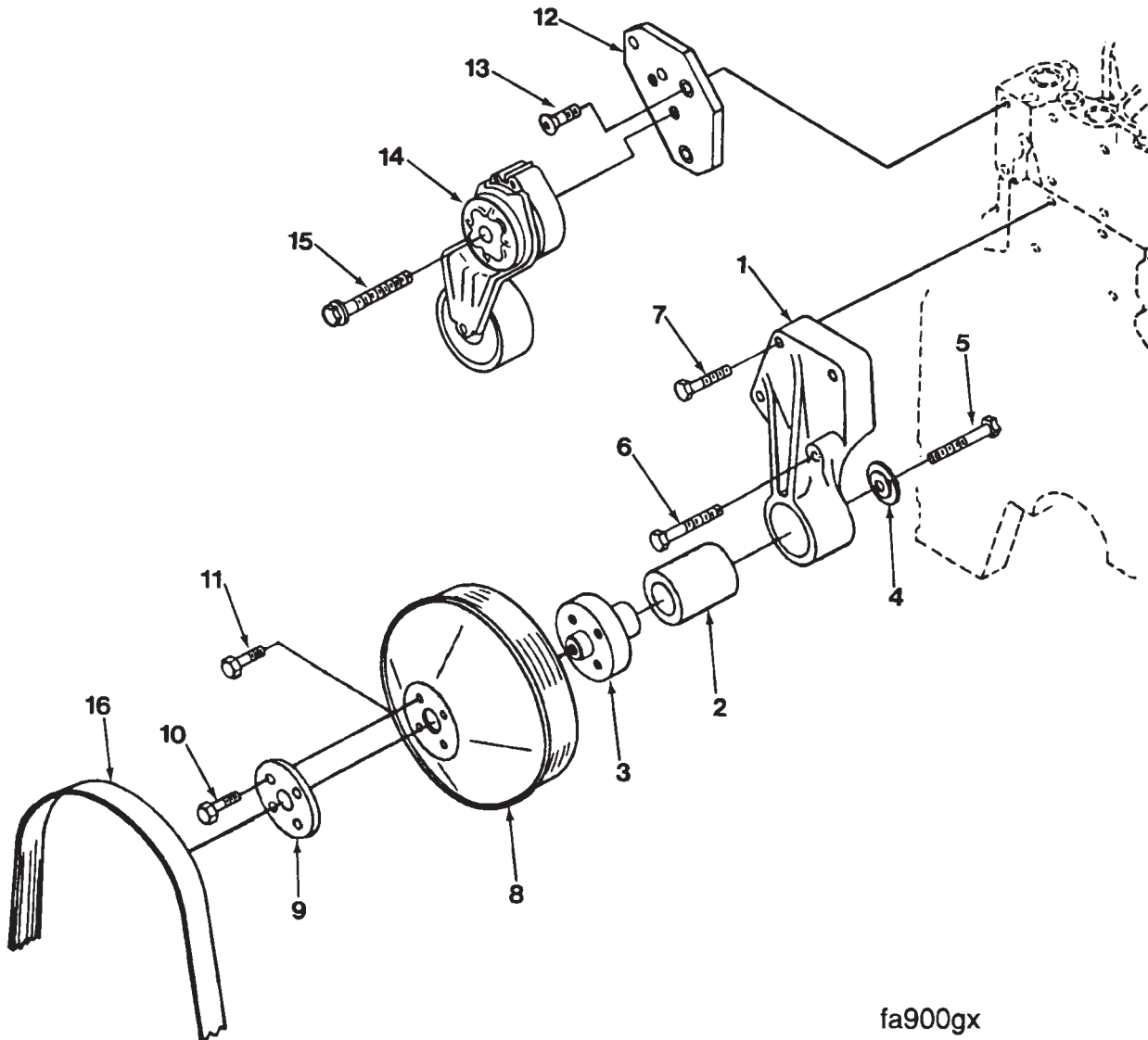

fa900gx

Ref. No.	Part Name	Qty.	Remarks
1	Support, Fan	1	Mounts to block.
2	Bearing, Ball	1	
3	Hub, Fan	1	27.0 mm Thick, 25.4 mm Dia. Shaft
4	Retainer, Fan	1	
5	Screw, Hex Hd Cap	1	M12-1.75x70 mm
6	Screw Hex Hd Cap	1	M8-1.25x75 mm
7	Screw, Hex Hd Cap	3	M8-1.25x30 mm
8	Pulley, Fan	1	
9	Plate, Clamping	1	
10	Screw, Cap	4	M8-1.25x20 mm
11	Screw, Cap	4	M8-1.25x16 mm
12	Bracket, Belt Tens.	1	
13	Screw, Flat Head Cap	2	M8-1.25x25
14	Tensioner, Belt	1	
15	Screw, Hex Hd Cap	1	M10-1.5x61.86 mm
16	Belt, V-ribbed	1	1524 mm Long

## Belt Tensioner and Fan Hub - General Information

### Belt Tensioner

The only practical repair for tensioners is pulley replacement.

Slight variations exist in the pulley removal and installation for each pulley version.

If the pulley exhibits excessive wear, a special service tensioner is available which features a hardened pulley with increased resistance to wear.

### Fan Hub - Inspection (8-02)

Inspect for free rotation of the fan hub shaft.

Check the end of the bearing for evidence that the lubricant has leaked. Rebuild or replace as required.

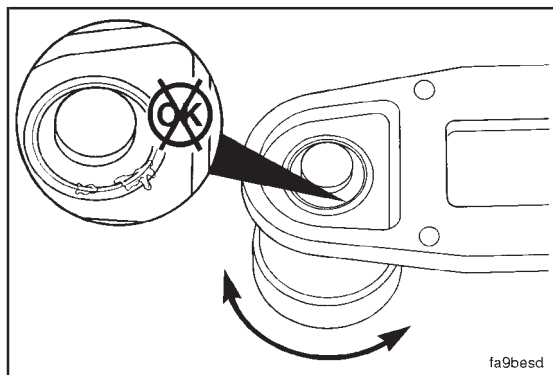

fa9besd

Inspect the fan hub bearing for wear. The bearing should have a minimal amount of side to side or end play movement. Replace the bearings if more than a minimal amount can be felt.

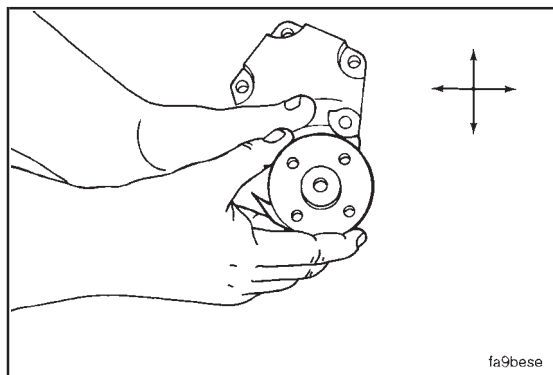

fa9bese

### Fan Hub - Disassembly (8-03)

16 mm

Secure fan hub and remove the center bolt and retainer.

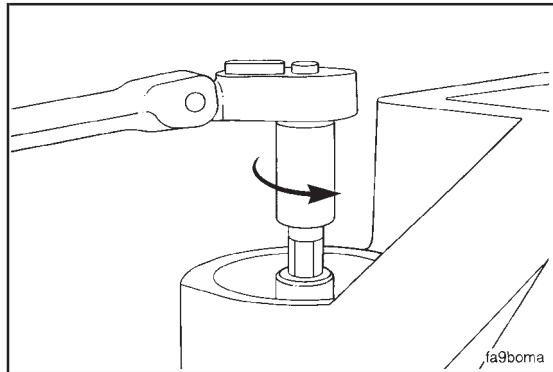

fa9boma

### Snap Ring Pliers

If the assembly is equipped with snap rings, remove the snap ring as illustrated.

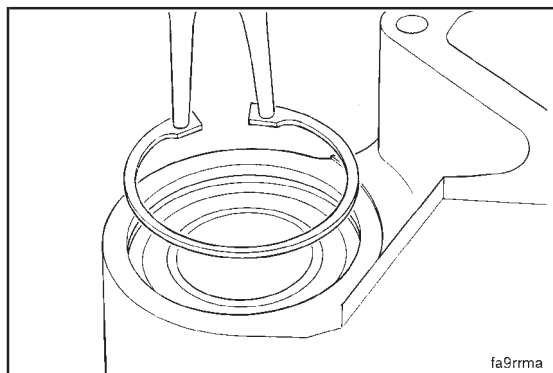

fa9rrma

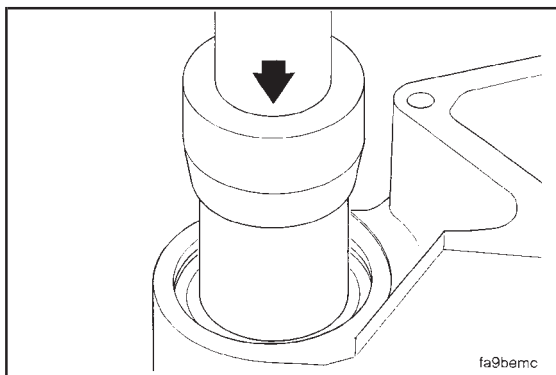

**1 inch Drift**

Support the fan hub bracket housing and press out the shaft/hub.



Approximately 6 tons of pressure is required.

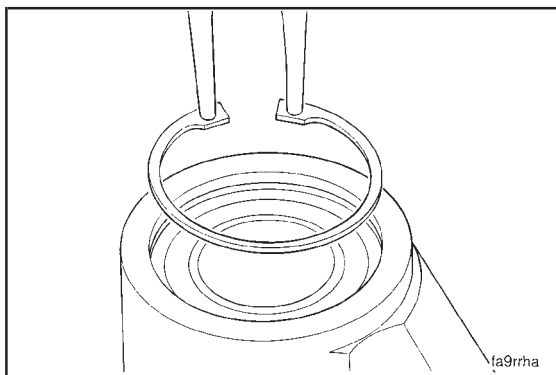

**Snap Ring Pliers**

Turn the bracket housing over and remove the snap ring if so equipped.

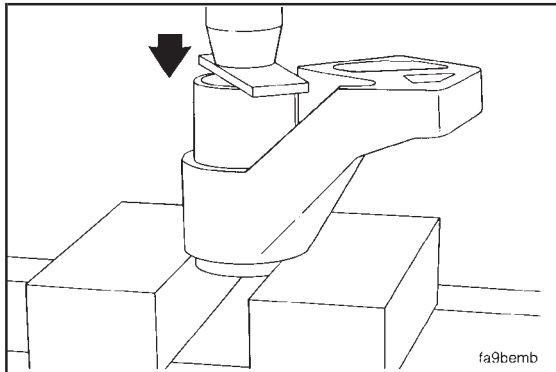

**2 Inch Pipe**

Press on the O.D. of the bearing to remove from the housing.

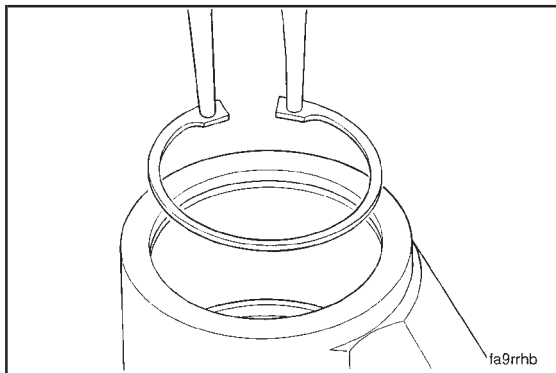

**Fan Hub Assembly (8-04)**

**Snap Ring Pliers**

If the bracket housing is equipped for snap rings, install the front snap ring.



**2 Inch Pipe**

Press the bearing flush with the front of the housing or to the snap ring.

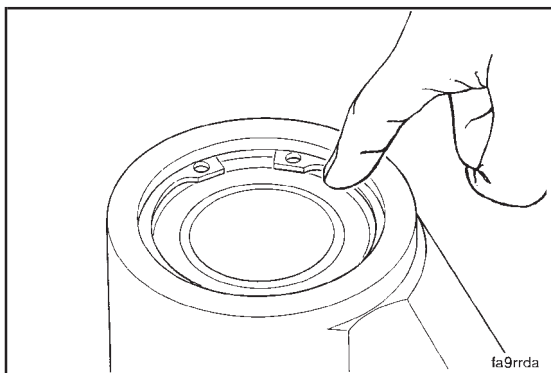

**Snap Ring Pliers**

Install the second snap ring if so equipped.

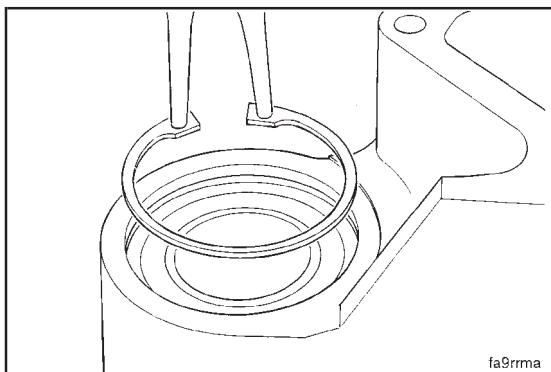

Supporting the bearing inner race with a 1.25 inch pipe coupling, press the hub/shaft in until it bottoms on the bearing.

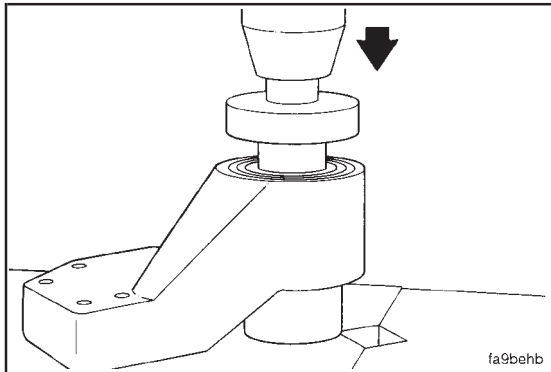

**16 mm**

Secure the assembly and install the retainer and center bolt. Tighten to 77 N•m [57 ft-lb].

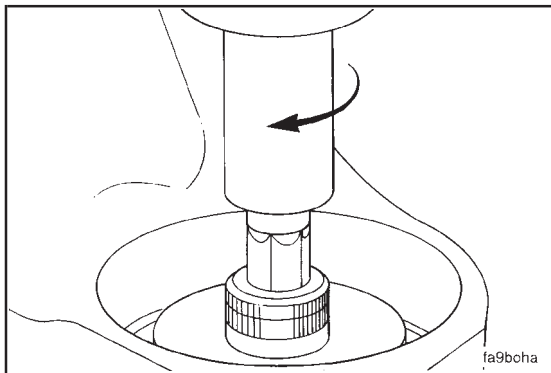



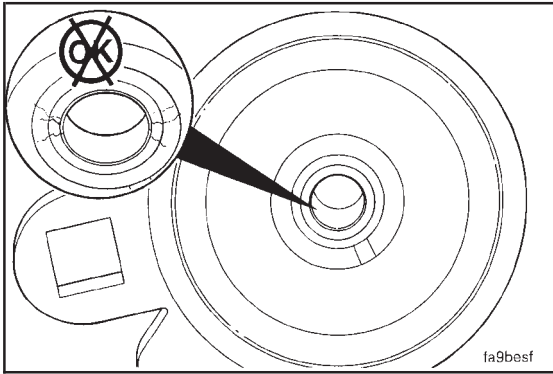

### Belt Tensioner - Inspection (8-05)

Inspect the pivot tube area of the tensioner for excessive wear evidenced by an elongated hole. If the tensioner exhibits excessive wear, it must be replaced.

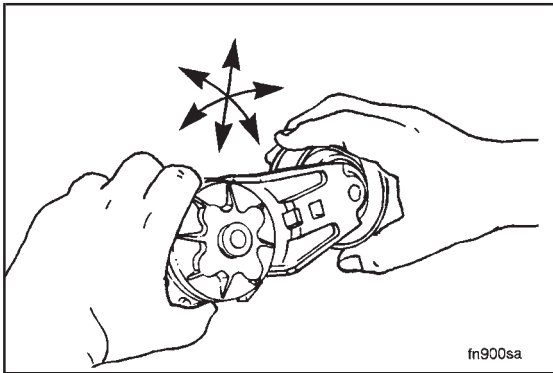

Roll the bearing and check that it rotates freely with no rough spots.

Thermostat Housing Assembly - Exploded View

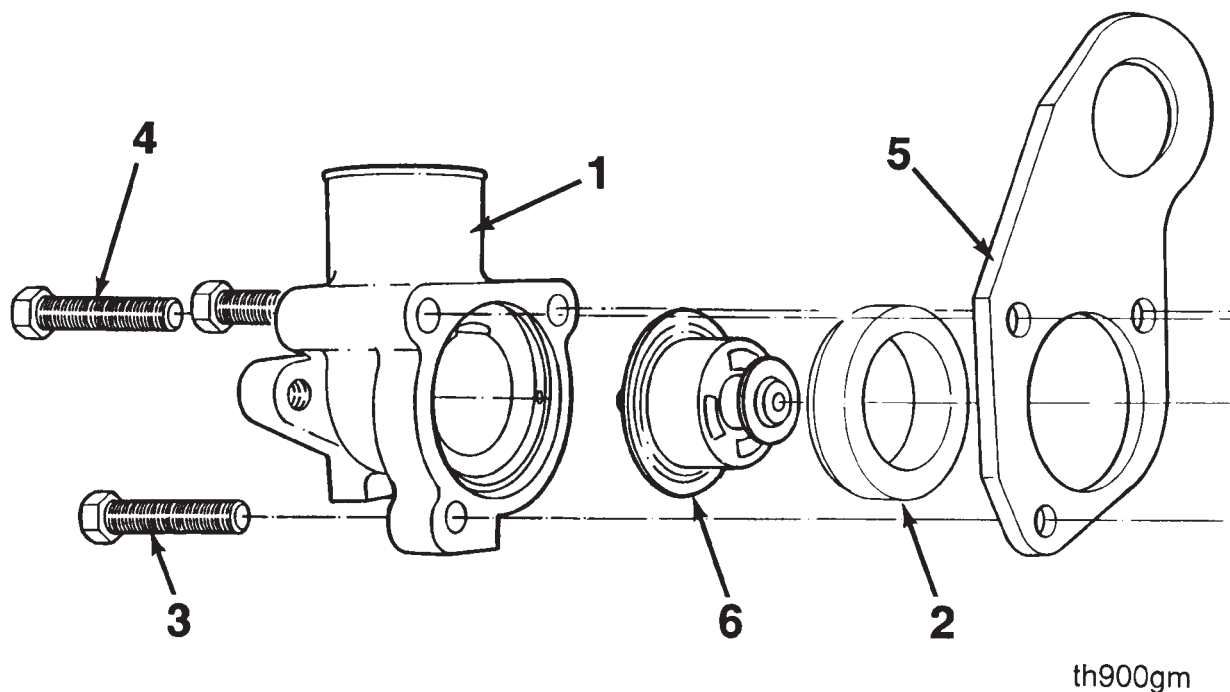

Ref. No.	Part Name	Qty.	Remarks
1	Housing, Thermostat	1	
2	Gasket, Thermostat Housing	1	
3	Screw, Hex Hd Cap	1	M8-1.25x35
4	Screw, Hex Hd Cap	2	M8-1.25x70
5	Bracket, Lifting	1	
6	Thermostat Coolant	1	

## Thermostat Housing Assembly - General Information

A pressure balanced thermostat is used on the B Series.

No special orientation is required with the new thermostat. The thermostat is compatible with thermostat housings which have a groove cut for the old thermostat tang.

### Thermostat - Inspection (8-06)

Visually inspect the thermostat for obvious damage such as obstructions caused by debris, broken springs, or stuck or missing vent pins.

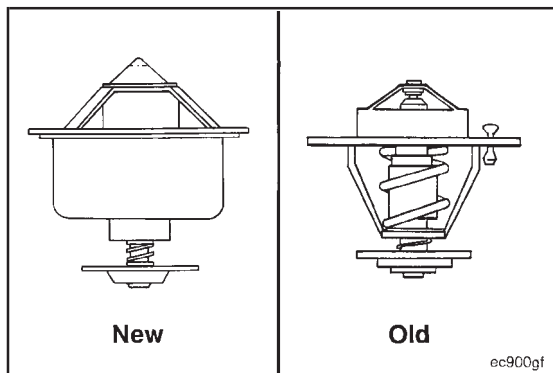

The thermostat can be checked for correct operation.

#### Requirements

**Start to open** at 83°C [181°F].

**Fully open** at 95°C [203°F].

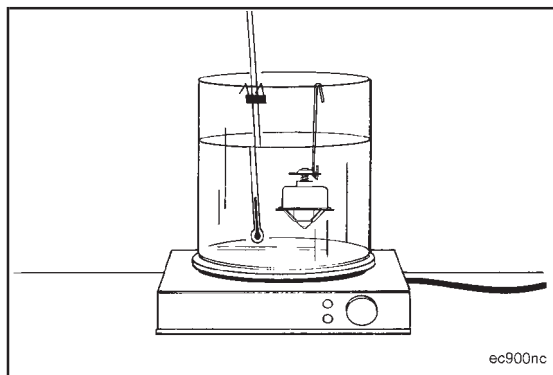

## General Information About Fans



**Warning:** Never attempt to rotate the engine by pulling or prying on the fan. This practice can result in serious personal injury and damage to the fan. Use only the proper engine barring techniques to manually rotate the engine.

Check the fan for missing balance weights at each regular maintenance interval. Do **not** attempt to repair broken or bent fans, or fans with missing balance weights.

Most equipment that has a Cummins engine uses a radiator and a fan. The radiator and fan transfer heat from the cooling water to the atmosphere. The fan selection process **must** conclude that the fan, the fan mounting arrangement, and the fan drive system are designed and matched for compatibility.

Upon request, Cummins Application Engineering Department will assist in determining the proper selection. Refer any fan changes other than the direct replacement of a fan with precisely the same Cummins part number, to the Cummins Application Engineering Department for prior approval.

Examples that require approval are,

1. Using an approved fan from one engine model on a different engine model.
2. Using an approved fan on an engine with a different fan mounting arrangement.
3. Using an approved fan on an engine with a different fan drive arrangement.
4. Converting an engine from one market model to another. An example is the conversion of a G-drive engine to a power unit application.
5. Converting an engine model to a different model. An example is converting a 6BT5.9 to a 6BTA5.9.

This list is **not** inclusive. **Always** contact Application Engineering for assistance.

At times an existing fan can yield **ONLY** marginal cooling capability when being considered for a new application.



**Caution:** Never repitch (bend) the blades to obtain additional air delivery. Bending the blades or spider creates stress in the material used for the construction of the fan. Repitching (bending) will cause fan failure. The proper diameter fan must be selected. Never modify an existing fan.

Application Engineering will provide assistance in the selection of a fan with the correct pitch and diameter for proper cooling.

# Section 9 - Drive Units - Group 9

## Section Contents

	Page
Accessory Drive - Cleaning .....	9-4
Accessory Drive - Inspection .....	9-4
Accessory Drive Adapter - Exploded View.....	9-2
Accessory Drive Adaptor - Assembly.....	9-5
Accessory Drive Adaptor - Disassembly .....	9-4
Drive Units - General Information.....	9-3
Accessory Drive Adapter .....	9-3

Accessory Drive Adapter - Exploded View

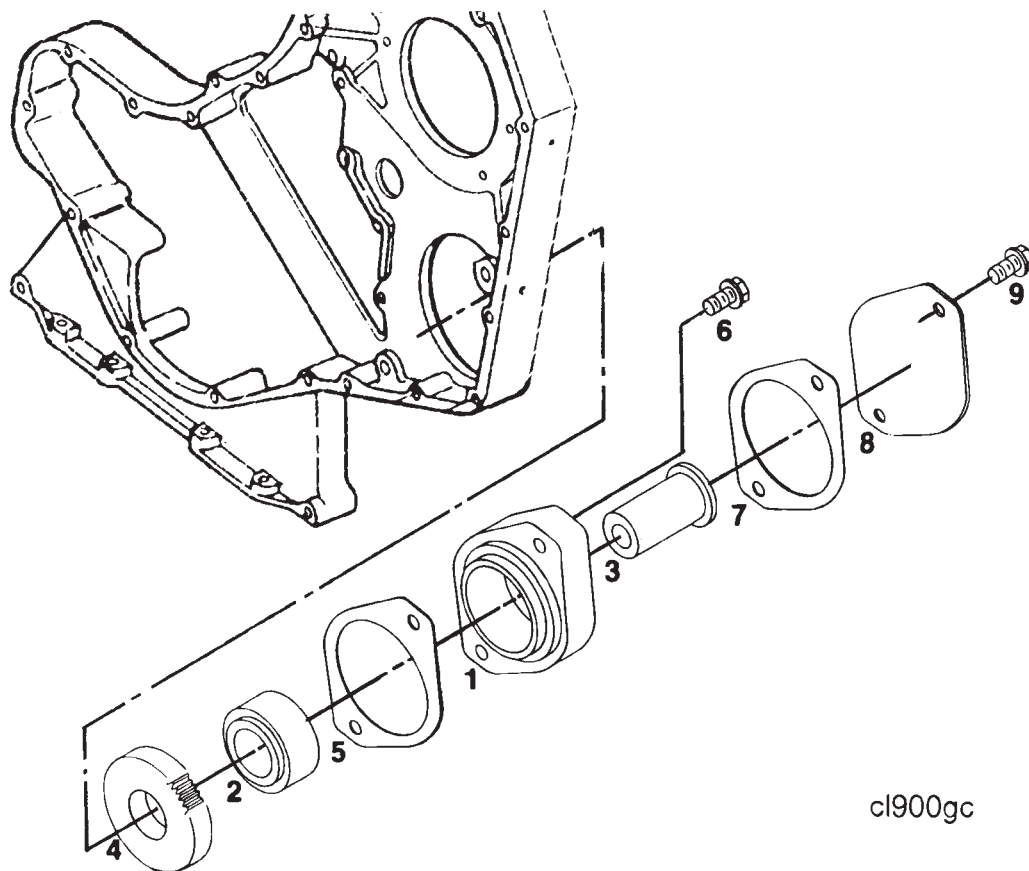

c1900gc

Ref. No.	Part Name	Qty.	Remarks
1	Adapter, Accessory Drive	1	
2	Bearing	1	
3	Shaft, Accessory Drive	1	
4	Gear, Accessory Drive	1	
5	Gasket, PTO Drive Cover	1	
6	Screw, Hex Hd Cap	2	
7	Gasket, PTO Drive Cover	1	
8	Plate, PTO Drive Cover	1	
9	Screw, Hex Hd Cap	2	

## Drive Units - General Information

### Accessory Drive Adapter

A gear driven adapter provides accessory drive capability of up to 142 N•m [105 ft. lb.] of torque. The accessory drive is equipped with either SAE A or B flange adapters.



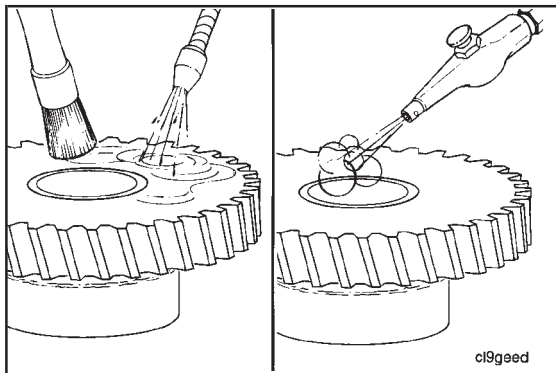

### Accessory Drive - Cleaning (9-01)

Clean the Accessory Drive with clean solvent and blow dry with compressed air.

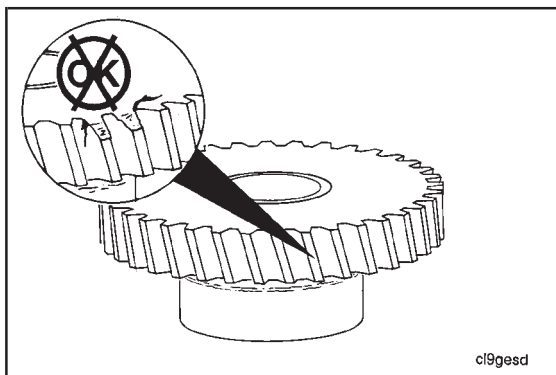

### Accessory Drive - Inspection (9-02)

Visually inspect for obvious damage such as cracks, broken teeth and damaged threads.

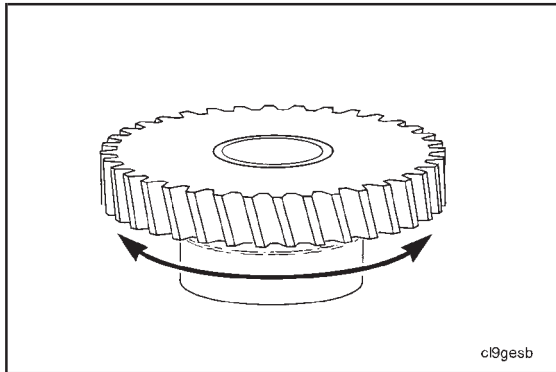

Rotate the gear and inspect for rough spots in the bearing and excessive wear.

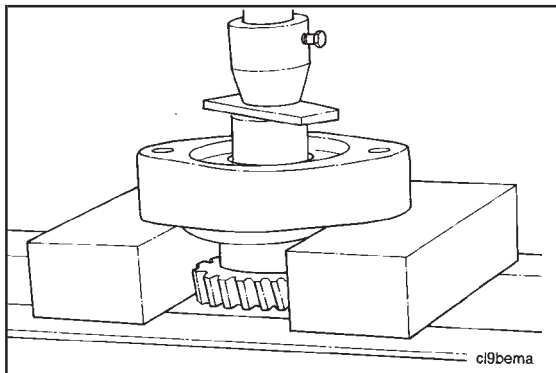

### Accessory Drive Adaptor - Disassembly (9-03)

#### 1.25 inch Pipe Coupling

Support the housing. Press the bearing, shaft, and gear assembly from the housing.



Approximately 4 tons of force is required.

**1 inch Drift**

Press the shaft and bearing assembly out of the gear.

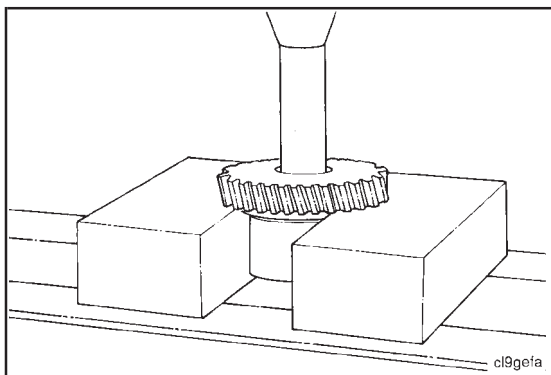

**1 inch Drift**

Support the bearing assembly and press the shaft from the bearing.

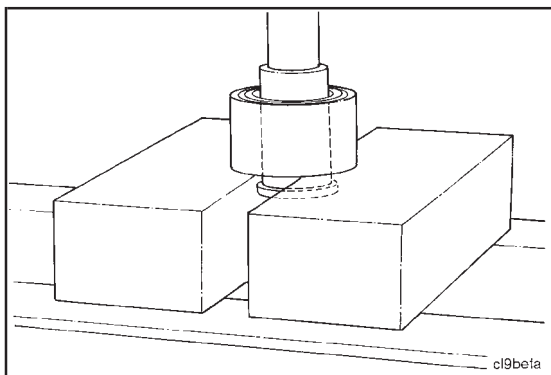

**Accessory Drive Adaptor - Assembly (9-04)**

**1.25 inch Pipe Coupling**

Support the inner race of the new bearing and press the shaft into the bearing until the shaft bottoms on the inner race.

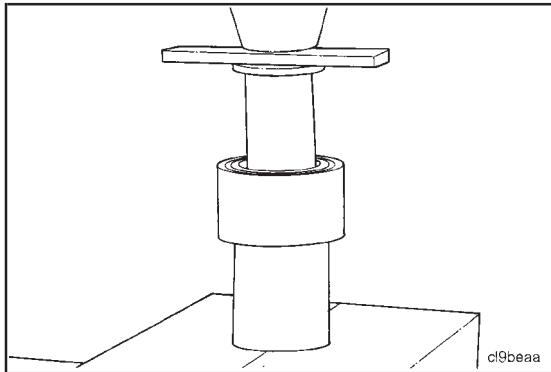

**2 inch Pipe**

**Caution: Press on the outer race of the bearing assembly. Pressing on the inner race will damage the bearing.**

Support the housing and press the bearing and shaft assembly in until it bottoms.

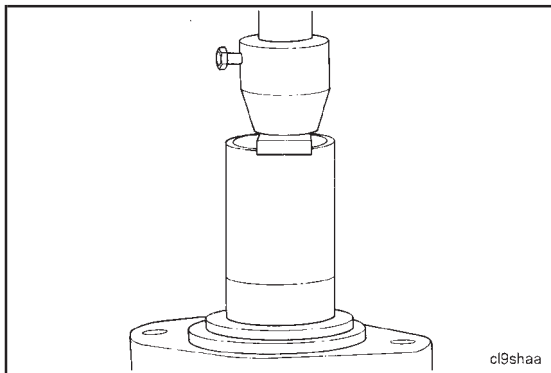

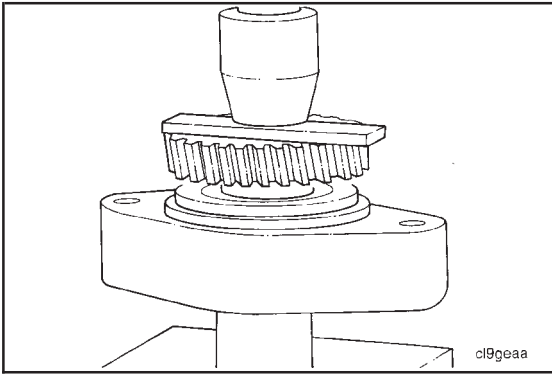

**1.25 inch Pipe Coupling**



Support the bottom of the shaft with a 1.25 inch pipe coupling and press the gear on until it bottoms against the inner-bearing race.

## Section 10 - Air Intake System - Group 10

### Section Contents

	Page
<b>Aftercooler Assembly - Cleaning and Inspection for Reuse</b> .....	10-6
Inspection .....	10-6
<b>Aftercooler Assembly - Rebuild</b> .....	10-7
<b>Air Crossover Tube - Cleaning and Inspection for Reuse</b> .....	10-8
Cleaning .....	10-8
Inspection .....	10-8
<b>Air Intake System - Exploded View</b> .....	10-2
<b>Air Intake System - General Information</b> .....	10-4
<b>Air Transfer Pipe - Cleaning and Inspection for Reuse</b> .....	10-7
Cleaning .....	10-7
Inspection .....	10-8
<b>Charge Air Cooler (CAC) - Cleaning and Inspection for Reuse</b> .....	10-8
Cleaning .....	10-8
Inspection .....	10-9
<b>Charge Air Cooler (CAC) - Pressure Testing</b> .....	10-9
<b>Turbocharger - Cleaning and Inspection for Reuse</b> .....	10-5
Inspection .....	10-5

### Air Intake System - Exploded View

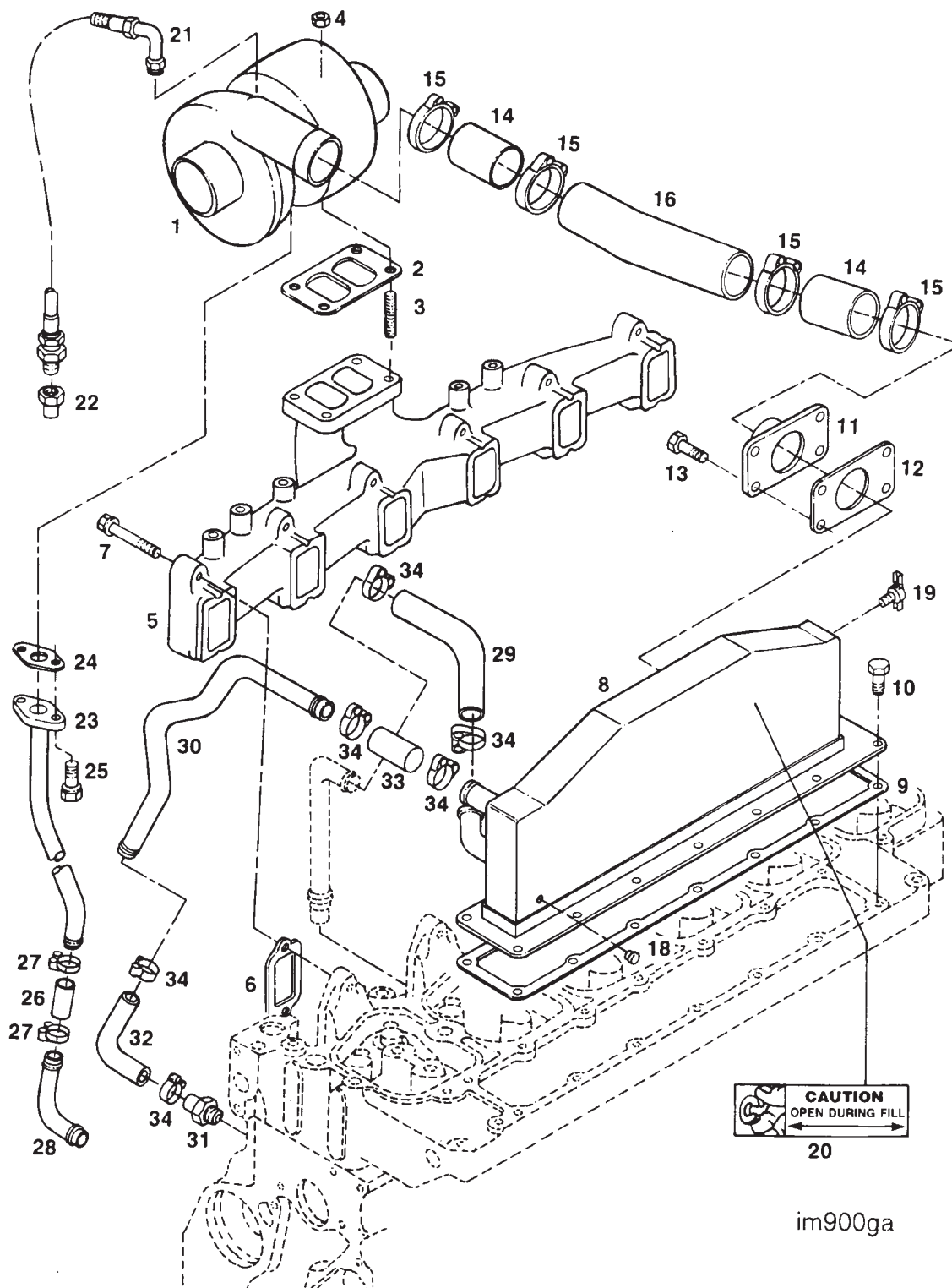

Ref. No.	Part Name	Req.	Remarks
1	Turbocharger	1	
2	Gasket, Turbocharger	1	
3	Stud	4	
4	Nut, Hexagon Flange	4	
5	Manifold, Exhaust	1	
6	Gasket, Exhaust Manifold	6	
7	Screw, Hexagon Head Cap	12	M10 - 1.5 x 70mm
8	Aftercooler	1	
9	Gasket, Int Manifold Cover	1	
10	Screw, Hexagon Head Cap	14	M8 - 1.25 x 26mm
11	Connection, Air Crossover	1	
12	Gasket, Connection	1	
13	Screw, Hexagon Head Cap	4	M8 - 1.25 x 25mm
14	Hose, Plain	2	
15	Clamp, Hose	4	
16	Tube, Air	1	
18	Plug, Pipe	1	
19	Draincock	1	
20	Decal	1	
21	Hose, Flexible	1	
22	Connector, Female	1	
23	Connection, Tur Oil Drain	1	
24	Gasket, Oil Drain	1	
25	Screw, Hexagon Head Cap	2	M8 - 1.25 x 20mm
26	Hose, Plain	1	
27	Clamp, Hose	2	
28	Tube, Tur Oil Drain	1	
29	Hose, Elbow	1	
30	Tube, Aftercooler	1	
31	Coupling, Plain Hose	1	
32	Hose, Molded	1	
33	Hose, Plain	1	
34	Clamp, Hose	6	

## Air Intake System - General Information

The air intake system for the B Series turbocharged and aftercooled engines, Models 4BTA3.9 and 6BTA5.9, consists of the aftercooler and connections, air crossover hardware, turbocharger, and associated hardware.

The turbocharged engines, Models 4BT3.9 and 6BT5.9 use a manifold cover in place of the aftercooler.

The air intake system for the naturally aspirated engines, Models 4B3.9 and 6B5.9 consists of the manifold cover mounted to the intake manifold in the cylinder head.

The air intake system for the B Series automotive engines, Models B3.9 and B5.9, consists of the turbocharger, the charge air cooler, turbocharger-to-charge air cooler hardware, charge air cooler-to-intake manifold cover hardware, intake manifold cover, and associated hardware. On the higher horsepower ratings of the B5.9 engine, the turbocharger is equipped with a wastegate which limits the amount of boost pressure.

The turbocharger is cooled and lubricated with engine oil from the engine lubricating system.

The instructions for rebuilding the turbocharger are printed in Turbocharger Shop Manual Bulletin No. 3810321.

**Caution:** If the engine experiences a turbocharger failure or any other occasion where oil or debris can enter the charge air cooler (CAC), the CAC must be cleaned (refer to Procedure 10-06).

### Turbocharger - Cleaning and Inspection for Reuse (10-01)

Remove all carbon deposits and gasket material from surfaces (1), (2), and (3).

**Warning:** When using a steam cleaner, wear protective clothing and safety glasses or a face shield. Hot steam will cause serious personal injury.

**Caution:** Tape or plug all openings to prevent solvent or steam from damaging the oil cavities in the turbocharger.

Use solvent or steam to clean the exterior of the turbocharger. Dry with compressed air.

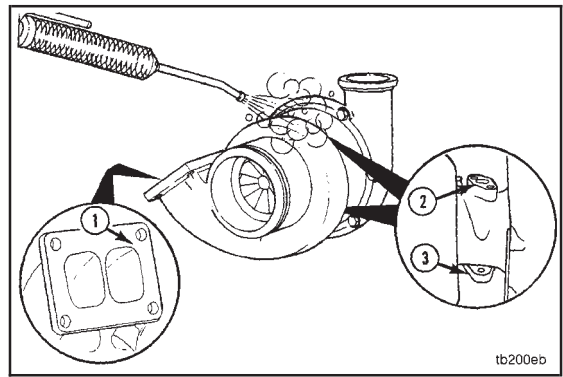

tb200eb

### Inspection

Visually inspect the housings for damage.

Visually inspect the turbine wheel and compressor impeller (1) for fretting, cracked or broken vanes.

Turn the impeller in the direction shown with arrow (2), to inspect the turbine shaft for freedom of rotation. The shaft **must** rotate freely.

Replace damaged parts.

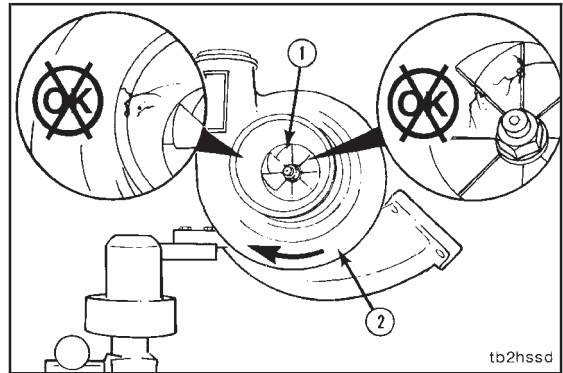

tb2hssd

Measure the turbocharger shaft end clearance with the Part No. ST-537 Dial Depth Gauge.

Push the rotor assembly away from the gauge.

Set the gauge on zero.

Push the rotor assembly toward the gauge and record the data.

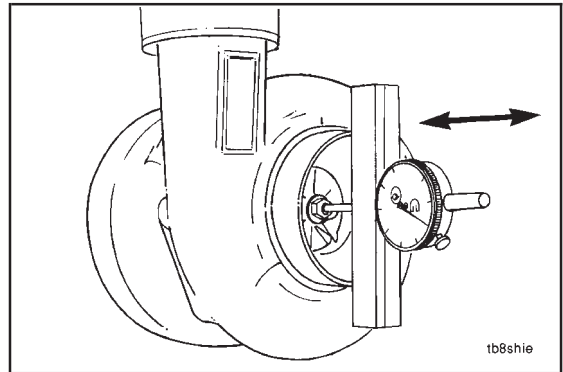

tb8shie

		End Play	
mm			in
0.03	MIN		[0.001]
0.08	MAX		[0.003]



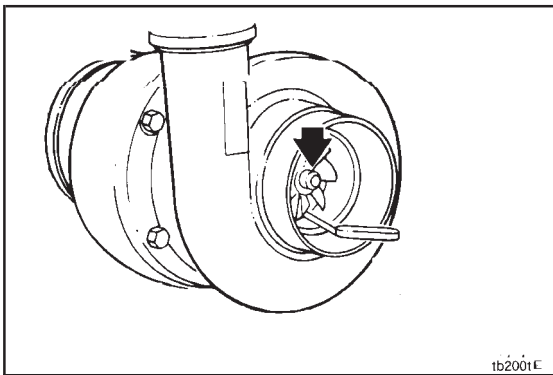

Push the compressor impeller by hand toward the compressor housing.



Install a wire feeler gauge, at the minimum clearance point, between the impeller and the housing to measure the clearance.

Record this clearance.

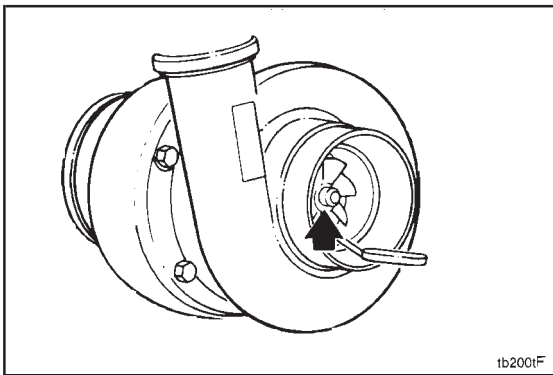

With the feeler gauge in the same location, push the turbine wheel by hand away from the compressor housing.



Install a wire feeler gauge, at the same point.

Record this clearance.

Subtract the smaller from the larger clearance.

Radial Clearance		
mm		in
0.30	MIN	[0.012]
0.46	MAX	[0.018]

If the radial clearance does **not** meet the above specifications, the turbocharger **must** be rebuilt. Refer to Turbocharger Components Shop Manual, Bulletin No. 3810321, for rebuild instructions.

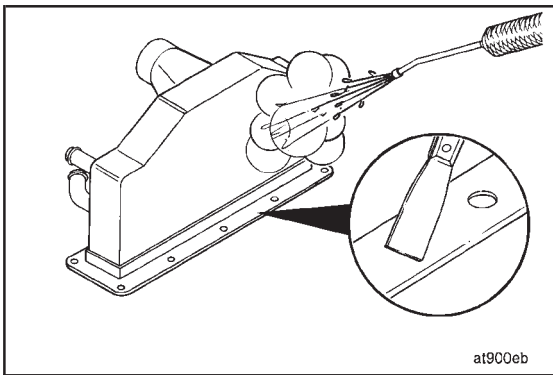

Remove all gasket material from the mounting surfaces.



**Warning:** When using a steam cleaner, wear protective clothing and safety glasses or a face shield. Hot steam will cause serious personal injury.



Use solvent or steam to clean the aftercooler assembly. Dry with compressed air.

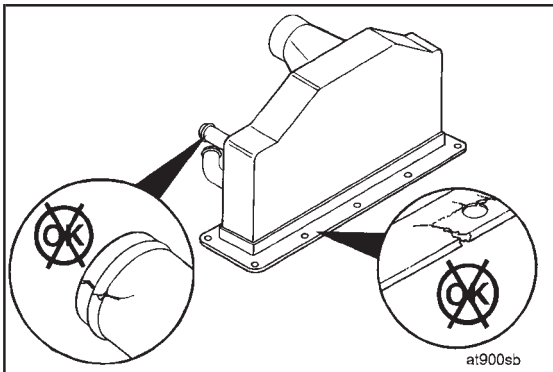

### Inspection

Visually inspect the aftercooler assembly for cracks or damage. Replace if damaged.

**Pressure Test the Aftercooler Core**

Install the hose, hose clamps, and solid pipe plug (1) onto the inlet tube.

Install the hose and hose clamps (2), and air pressure gauge (3) onto the outlet tube.

Connect the air pressure gauge to a regulated air supply.

**Air Pressure:** 552 kPa [50 psi]

Submerge the aftercooler in a tank of water.

If air bubbles appear, the core is damaged and the aftercooler **must** be replaced.

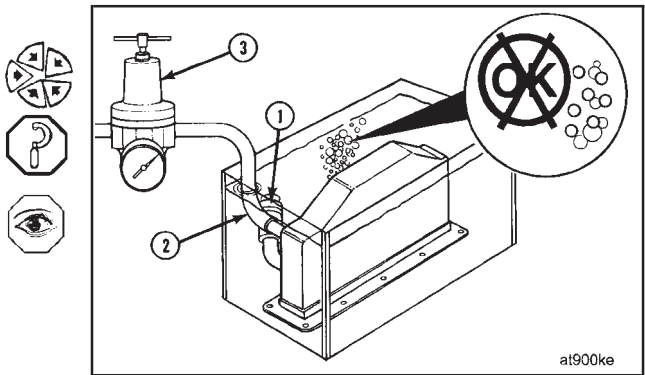

Remove the aftercooler from the water tank.

Remove the test equipment.

Use compressed air and dry the aftercooler.

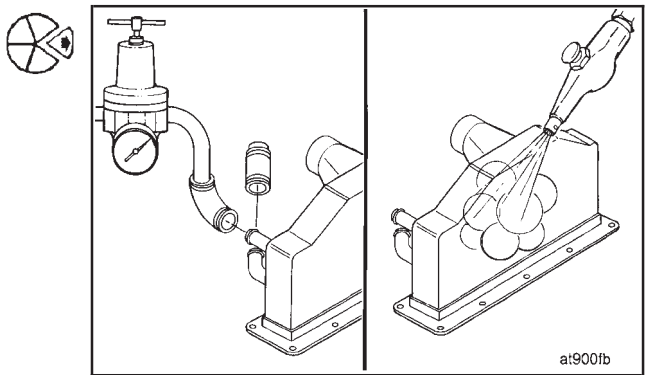

**Aftercooler Assembly - Rebuild (10-03)**

**Caution:** The aftercooler is a unitized assembly and cannot be rebuilt. Any attempt to repair the aftercooler core will reduce the coolant flow and cause future engine damage.

Refer to Aftercooler Assembly - Cleaning and Inspection for Reuse (10-02).

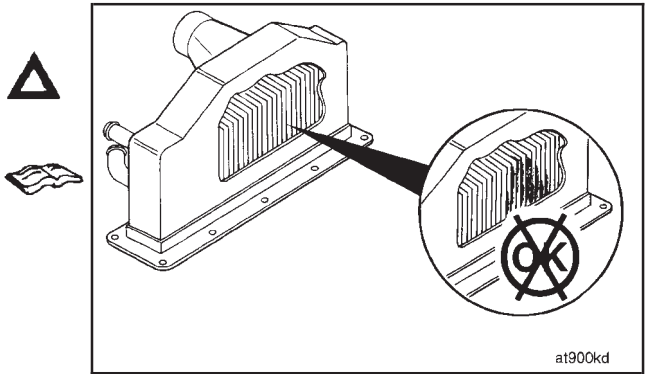

**Air Transfer Pipe - Cleaning and Inspection for Reuse (10-04)**

**Cleaning**

**Warning:** When using a steam cleaner, wear protective clothing and safety glasses or a face shield. Hot steam will cause serious personal injury.

Use solvent or steam to clean the air transfer pipe. Dry with compressed air.

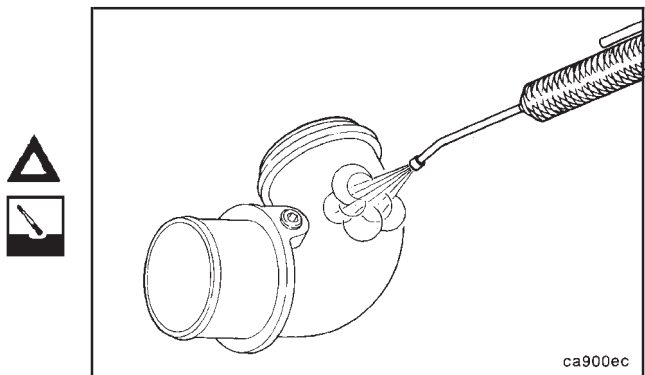

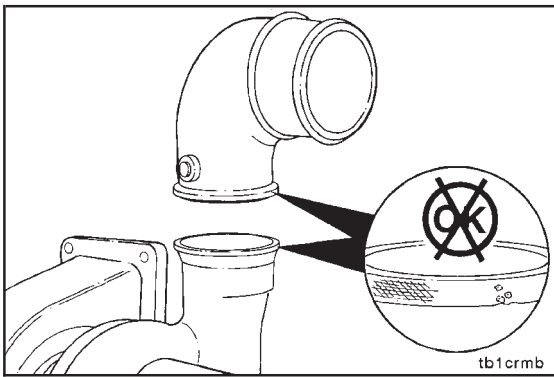

**Inspection**

Visually inspect the turbocharger compressor V-band outlet and the air transfer pipe connection for dents or fretting.

Replace the turbocharger compressor housing or air transfer pipe, if damaged.

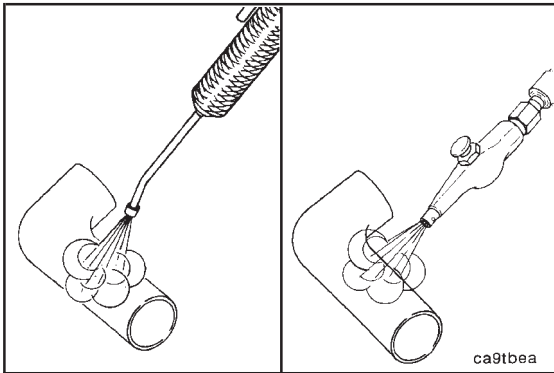

**Air Crossover Tube - Cleaning and Inspection for Reuse (10-05)**

**Cleaning**



**Warning:** When using a steam cleaner, wear protective clothing and safety glasses or a face shield. Hot steam will cause serious personal injury.



Use solvent or steam to clean the air crossover tube. Dry with compressed air.

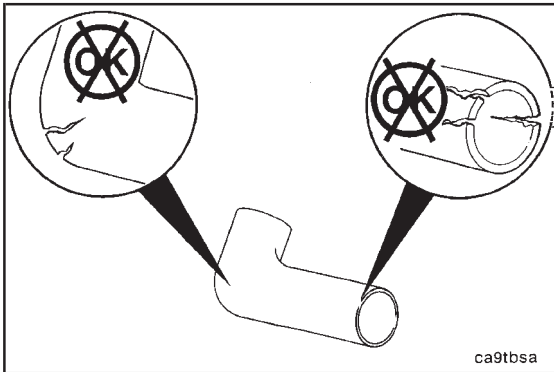

**Inspection**

Visually inspect the air crossover tube for cracks or damage.

Visually inspect the hose sealing surfaces for pitting or damage. Replace damaged parts.

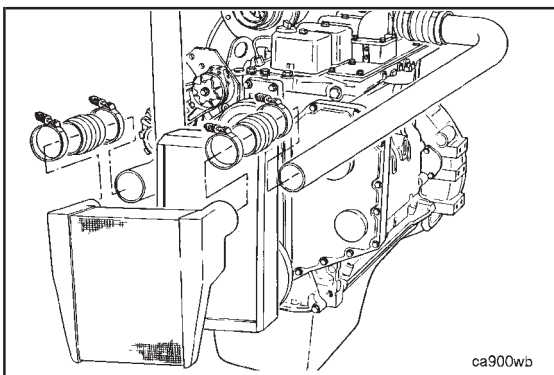

**Charge Air Cooler (CAC) - Cleaning and Inspection for Reuse (10-06)**

**Cleaning**



**Caution:** If the engine experiences a turbocharger failure or any other occasion where oil or debris is put into the CAC, the CAC must be cleaned.



Remove the CAC from the vehicle. Refer to the vehicle manufacturer for instructions.

**Caution:** Do not use caustic cleaners to clean the CAC. Damage to the CAC will result.

**NOTE:** Make sure that the tubes are in the vertical direction when flushing.

Flush the CAC internally with solvent in the opposite direction of normal air flow. Shake the CAC and lightly tap on the end tanks with a rubber mallet to dislodge trapped debris. Continue flushing until all debris or oil is removed.

**NOTE:** If internal debris cannot be removed, scrap the CAC.

Use a flashlight and mirror to visually inspect the CAC for internal debris.

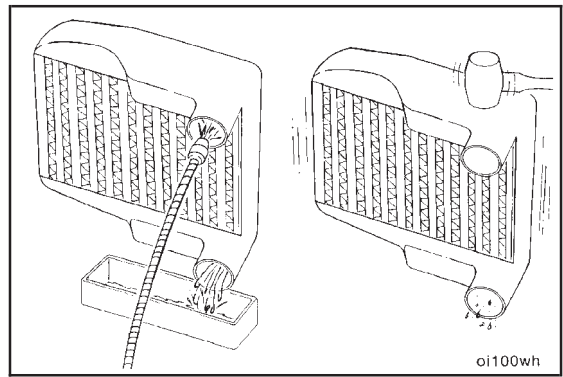

After the CAC has been thoroughly cleaned of all oil and debris with solvent, wash the CAC internally with hot soapy water to remove the remaining solvent. Rinse thoroughly with clean water.

Blow compressed air into the CAC in the opposite direction of normal air flow until the CAC is dry internally.

**Caution:** The CAC must be rinsed, dried, and free of solvent, oil, and debris or engine damage will result.

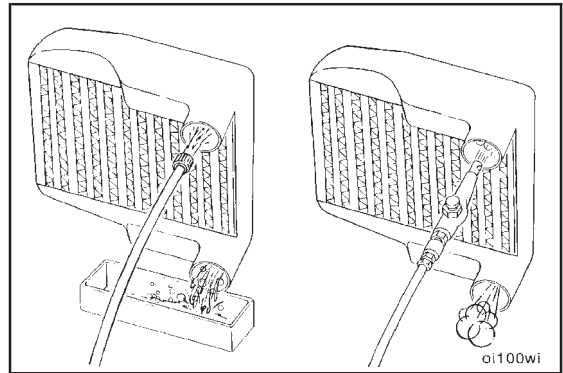

### Inspection

Visually inspect the CAC for cracks, holes or damage.

Inspect the tubes, fins and welds for tears, breaks or other damage. If any damage causes the CAC to fail the air leak check mentioned in Procedure (10-07), the CAC **must** be replaced.

Install the CAC on the vehicle. Refer to the vehicle manufacturer for instructions.

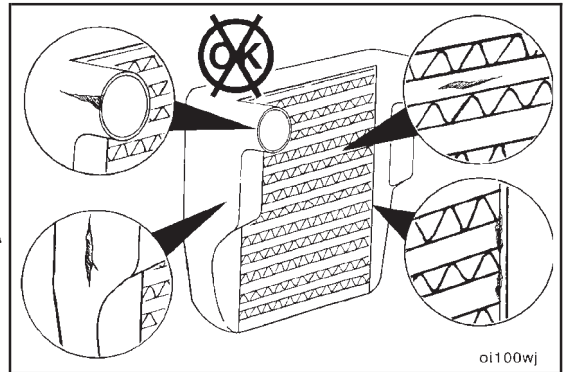

### Charge Air Cooler (CAC) - Pressure Testing (10-07)

To check the charge air cooler for cracked tubes or header, remove the inlet and outlet hoses from the CAC.

Remove the charge air cooler. Refer to the vehicle manufacturer for instructions.

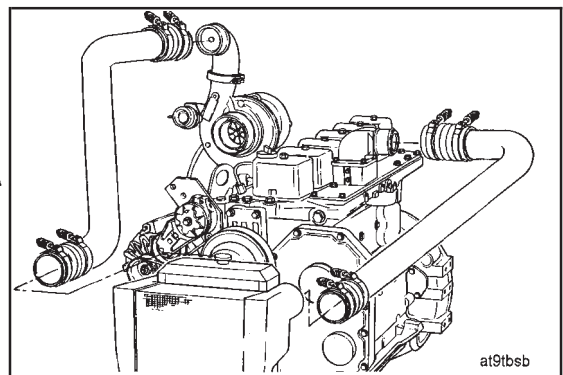

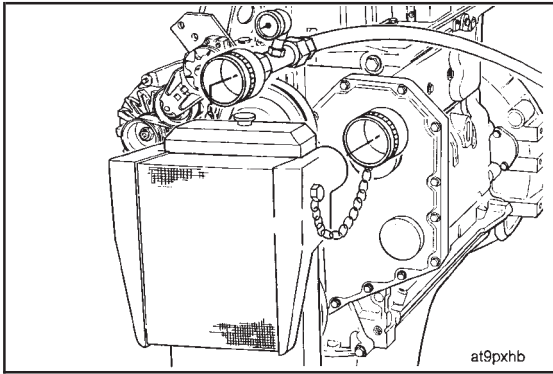

**3824556 Test Kit**

Install a cap over the outlet side of the CAC. Install a pressure gauge, air supply, and air pressure regulator to the inlet side of the cooler.



**Warning:** To prevent possible injury if either plug blows off during the test, secure safety chains on the test plugs to any convenient capscrew on the radiator assembly. This test must be performed with securely fastened safety chains.

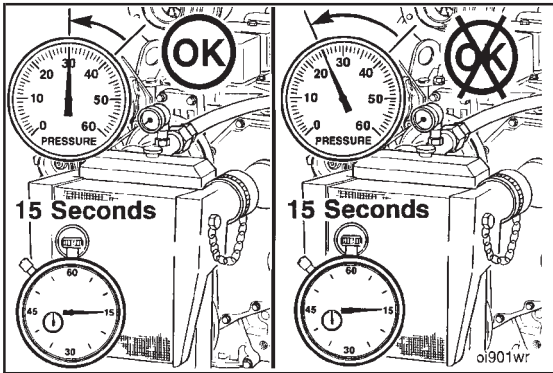

Apply 207 kPa [30 psi] of air pressure to the cooler. Close the air pressure regulator.

Monitor the pressure gauge and determine the rate of pressure decay with a stop watch.

If the pressure decay is 49 kPa [7 psi] or less in 15 seconds, the cooler is okay. If the pressure drop is greater than 49 kPa [7 psi] in 15 seconds, check all connections again.

Determine if pressure decay is caused by a leak in the CAC or from a leaky connection. Use a spray bottle filled with soapy water applied to all hose connections, and watch for bubbles to appear at the location of the leak.

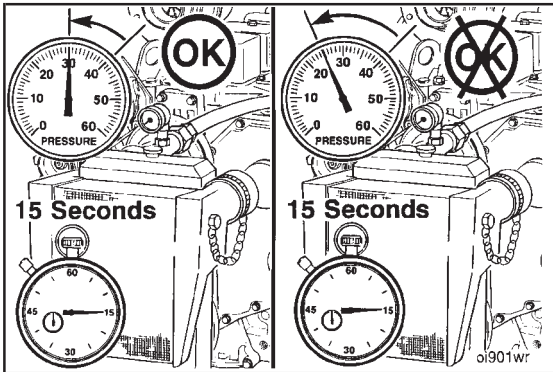

If the pressure decay is caused by a leaky connection, repair the connection and repeat the test. If the leak is within the CAC, repeat the test to verify the accuracy of the pressure decay measurement. Similar pressure decay readings **must** be obtained at least three consecutive tests before the reading can be considered accurate.

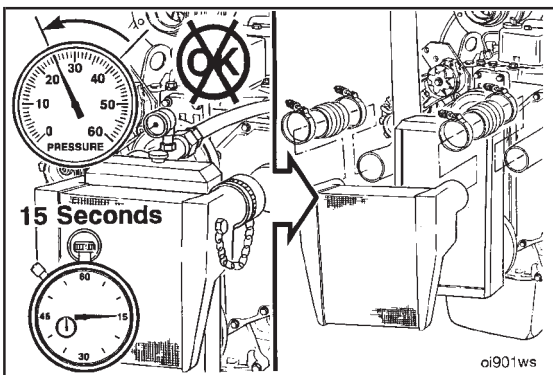

If the pressure drop is greater than 49 kPa [7 psi] in 15 seconds, the CAC **must** be replaced.

Refer to the manufacturer's repair manual for replacement instructions.

**NOTE:** Charge air coolers are not designed to be 100% leak free. If the pressure decay is less than 49 kPa [7 psi] in 15 seconds, then the CAC does not need to be replaced.

# Section 11 - Exhaust System - Group 11

## Section Contents

	Page
Exhaust Manifold - Exploded View .....	11-2
Exhaust Manifold Inspection.....	11-4
General Information .....	11-3
Exhaust Manifold .....	11-3
Turbocharger Mounting Stud Replacement.....	11-4

### Exhaust Manifold - Exploded View

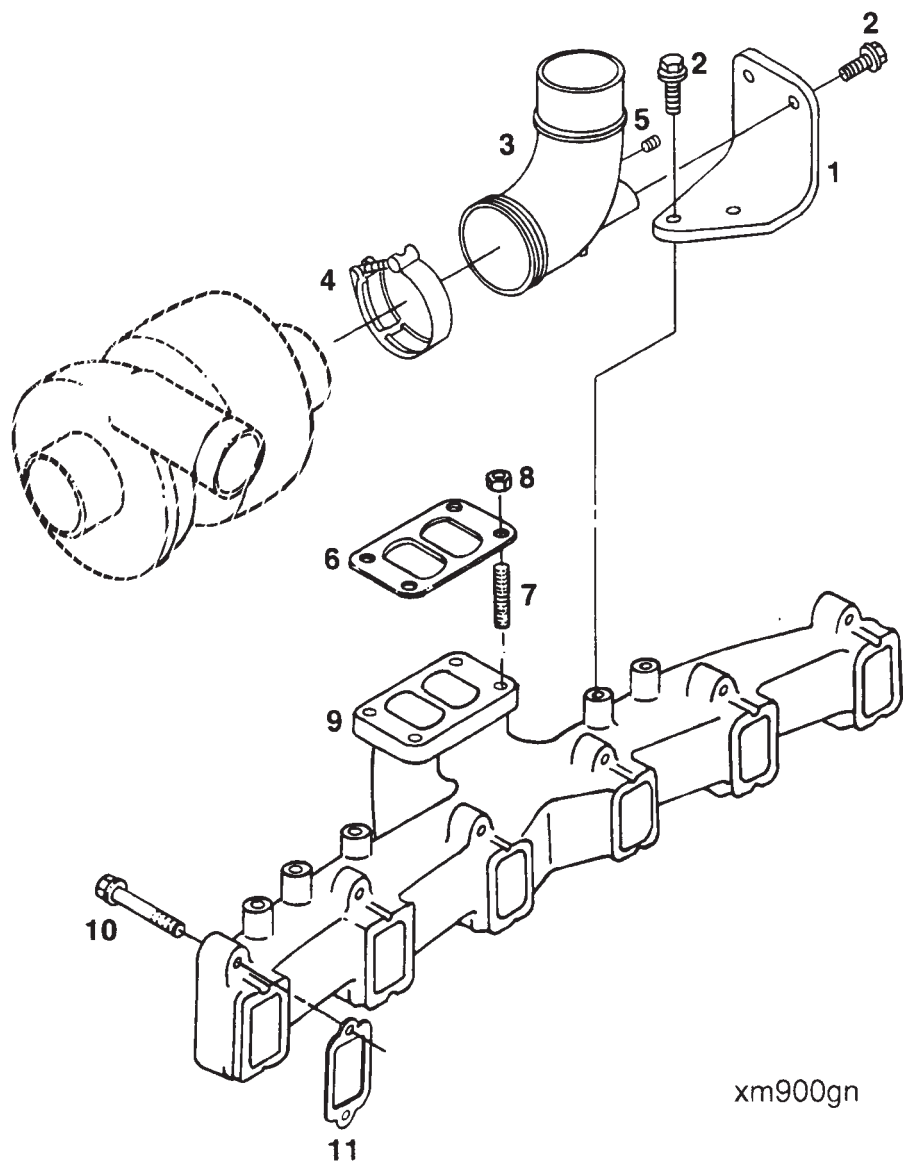

xm900gn

Ref. No.	Part Name	Qty	Remarks
1	Brace, Exh. Out Conn.	1	90 degree turbo exhaust elbow
2	Screw, Hex Hd Cap	4	
3	Connection, Exh. Out	1	
4	Clamp, V Band	1	
5	Pipe, plug	1	
6	Gasket, turbocharger	1	
7	Stud	4	
8	Nut	4	
9	Manifold, exhaust	1	
10	Screw, Hex Hd Cap	12	
11	Gasket, manifold	6	

## General Information

### Exhaust Manifold

The B series engine uses a pulse-type manifold with a divided turbocharger entry passage (exhaust manifold outlet). Multiple turbocharger locations are available to suit space constraints of various installations. Center, front, rear and high, low turbo mounting locations are offered.

Warping can be corrected by machining or grinding the sealing surfaces to the flatness specification.



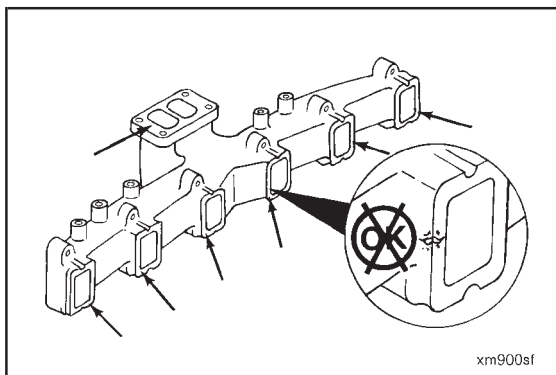

### Exhaust Manifold Inspection (11-01)

Inspect the Exhaust Manifold for cracks, burn-out, or damaged threads.

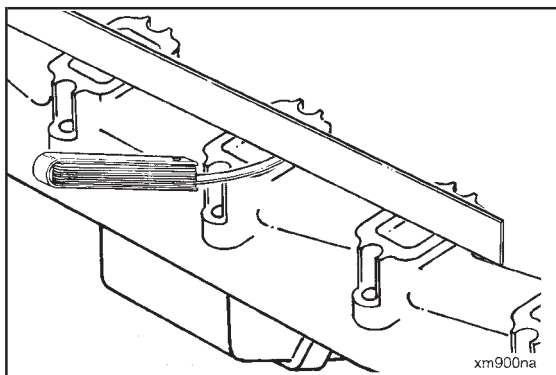

Place straight edge across the exhaust ports. The maximum allowable clearance between the manifold and straight edge is 0.10 mm [0.004 inch].

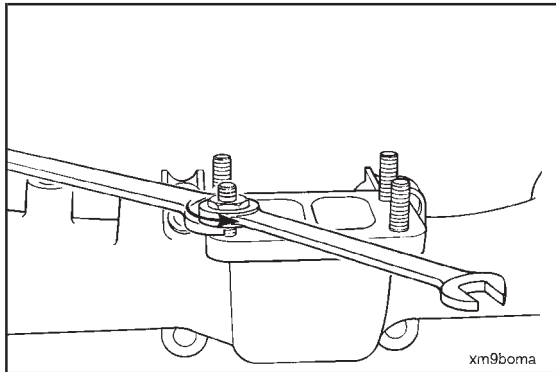

### Turbocharger Mounting Stud Replacement (11-02)

Inspect the turbocharger studs for damaged threads. To replace the studs, use two nuts jam locked on to the stud.

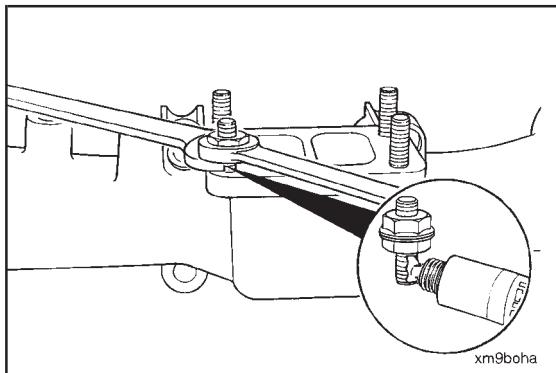

Before installing the studs, coat the threads with anti-seize compound.

# Section 12 - Air Equipment - Group 12

## Section Contents

	Page
<b>Air Compressor - Cleaning and Inspection for Reuse</b> .....	12-3
Inspection.....	12-3
<b>Air Equipment - General Information</b> .....	12-2
Air Compressor .....	12-2

## Air Equipment - General Information

### Air Compressor

The air equipment group consists of Cummins single and two cylinder air compressors, compressor check valves and air and coolant piping. Two cylinder air compressors used on B & C engines are normally manufactured by Bendix & Midland.

The air compressor is lubricated by engine lubricating oil which enters the compressor through a drilling in the support. The oil lubricates the connecting rod bearings and the crankshaft. The oil then flows to the air compressor crankcase and returns to the engine through a drain passage located in the air compressor support.

The air compressor is cooled by the engine coolant. Only the cylinder head is cooled on most single cylinder air compressors. Both the cylinder head and cylinders are normally cooled on the two cylinder air compressor.

Service information, specifications, and repair of Cummins air compressors are contained in the following publications:

Holset SS191 - Single Cylinder  
8.5 CFM Air Compressor  
Rebuild Manual  
Bulletin # 3810433

Holset SS296 - Single Cylinder  
13.2 C.F.M. Air Compressor  
Bulletin # 3810242

Holset SS338 - Single Cylinder  
15.0 CFM Air Compressor  
Bulletin # 3810457

Instructions for testing and repairing air cranking motors and air compressors **not** manufactured by Cummins, **can** be obtained from the original equipment manufacturers.

The following list contains the addresses of suppliers of air equipment for use on Cummins engines:

#### U.S.A.

Bendix H.V.S.G.  
901 Cleveland St.  
Elyria, OH 44036  
Attention: Technical Services Dept.

Engine Starting Systems  
Allen and Martinsville Rd.  
P.O. Box 1776  
Liberty Corner, NJ 07938

Midland Brake, Inc.  
490 South Chestnut St.  
Owosso, MI 48867

#### Canada

Bendix H.V.S.G.  
P.O. Box 5712  
1005 Wilton Grove Rd.  
London Ontario, Canada N6A4S8  
Attention: Technical Services Dept.

#### International

Bendix H.V.S.G. Europe Ltd.  
66 Grosvenor St.  
London, England W1X90B  
Attention: Technical Services Dept.

## Air Compressor - Cleaning and Inspection for Reuse (12-01)

Remove all gasket material from the sealing surfaces.

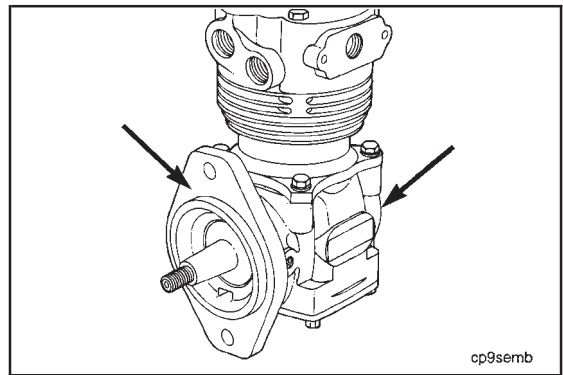

**Warning:** When using a steam cleaner, wear protective clothing and safety glasses or a face shield. Hot steam will cause serious personal injury.



**Caution:** Seal all openings with tape to prevent damage from solvent or steam entering the oil passages in the air compressor.



Use solvent or steam to clean the air compressor. Dry with compressed air.

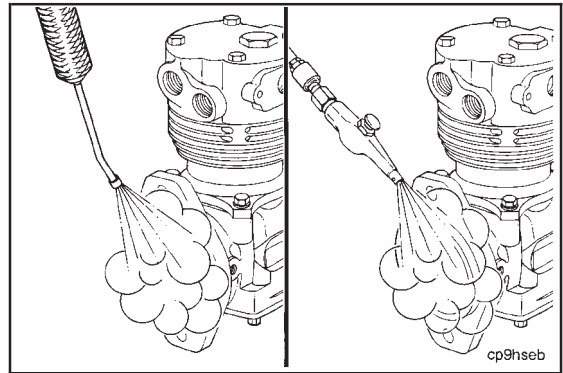

## Inspection

Visually inspect the compressor housing for cracks or damage.



Visually inspect the compressor gear drive for cracks or broken teeth.

Visually inspect the fuel pump drive hub or spider coupling for wear or damage.

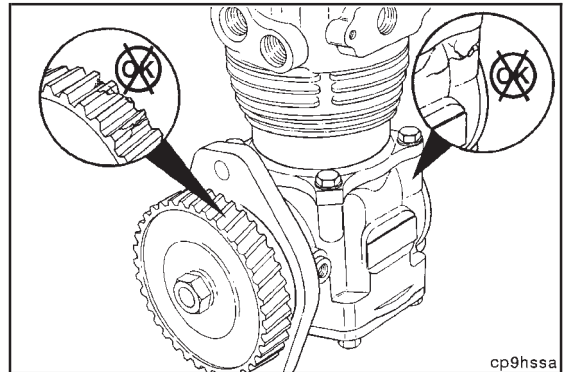

## Power Steering Coupling (if Applicable)

Inspect the coupling for wear or cracks.

Replace the coupling if damaged.

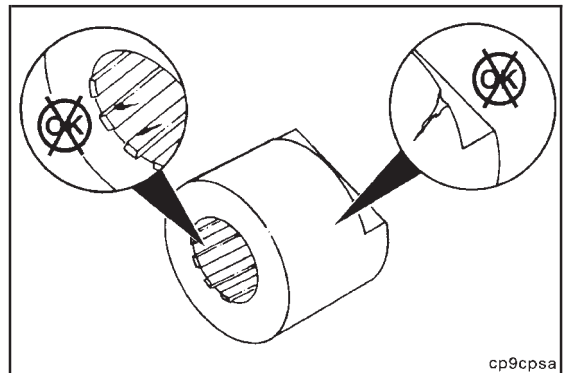

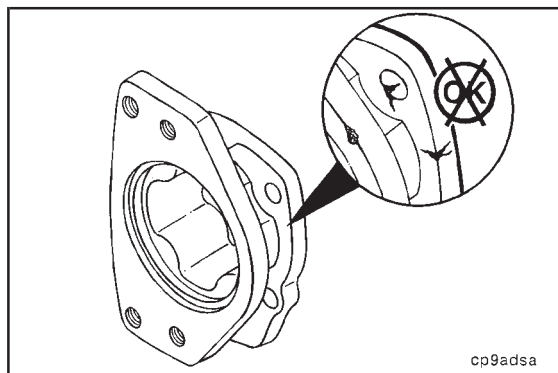

**Power Steering Adapter**

Inspect and replace the adapter if any damage is found.

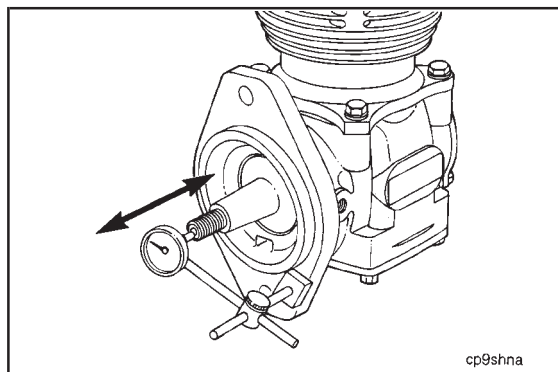

Measure the single cylinder air compressor crankshaft end clearance.

Crankshaft End Clearance		
mm		in.
0.05	MIN	0.002
0.15	MAX	0.006

# Section 13 - Electrical Equipment - Group 13

## Section Contents

	Page
Alternator Inspection .....	13-3
Electrical Equipment - General Information .....	13-2
Starter Inspection .....	13-3

## Electrical Equipment - General Information

The electrical equipment used on the B series engine is **not** manufactured by Cummins Engine Company, Inc. Complete instructions for adjusting, testing, and repairing the electrical equipment **can** be obtained from the equipment manufacturer. The following list contains the suppliers of the electrical equipment used on Cummins engines.

### Alternators

Robert Bosch Ltd.  
P.O. Box 166  
Rhodes Way  
Watford  
WD2 41B  
England  
Telephone: 0923-44233

Butec Electrics  
Cleveland Road  
Leyland  
PR5 1XB  
England  
Telephone: 0744-21663

C.A.V. Electrical Equipment  
P.O. Box 36  
Warple Way  
London  
W3 7SS  
England  
Telephone: 01-743-3111

A.C. Delco Components Group  
Civic Offices  
Central Milton Keynes  
MK9 3EL  
England  
Telephone: 0908-66001

Delco-Remy  
P.O. Box 2439  
Anderson, IN 46018  
U.S.A.  
Telephone: (317) 646-7838

Leece-Neville Corp.  
1374 E. 51st St.  
Cleveland, OH 44013  
U.S.A.  
Telephone: (216) 431-0740

### Electric Starting Motors

Butec Electrics  
Cleveland Road  
Leyland  
PR5 1XB  
England  
Telephone: 0744-21663

C.A.V. Electrical Equipment  
P.O. Box 36  
Warple Way  
London  
W3 7SS  
England  
Telephone: 01-743-3111

A.C. Delco Components Group  
Civic Offices  
Central Milton Keynes  
MK9 3EL  
England  
Telephone: 0908-66001

Delco-Remy  
P.O. Box 2439  
Anderson, IN 46018  
U.S.A.  
Telephone: (317) 646-7838

Nippendenso of Los Angeles  
3900 Via Oro Avenue  
Long Beach, CA 90810  
Telephone: (800) 222-6352

\* Non Electrical Equipment Suppliers

### Alternator Inspection (13-01)

Visually inspect the alternator for obvious damage such as a broken or cracked housing. Damaged fan blades or pulleys and worn mounting holes in the alternator end frames.

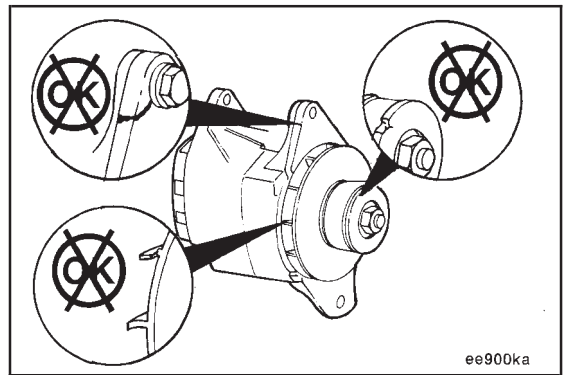

### Starter Inspection (13-02)

Visually inspect the gear (1) for cracked or broken teeth.

Visually inspect the drive bushing (2) and the gear shaft (3) for excessive wear or damage.

Visually inspect the terminal posts (4) for loose or broken connections.

**NOTE:** If the starting motor parts are damaged or the posts are loose or damaged, the starting motor **must** be repaired or rebuilt. Refer to the electrical equipment manufacturers specifications to rebuild the starting motor.

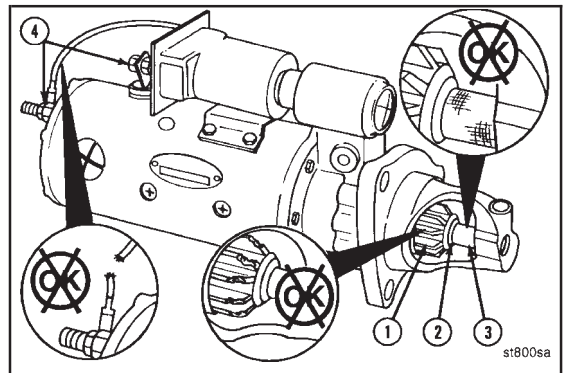





## Section 14 - Engine Testing - Group 14

### Section Contents

	Page
<b>Blowby Measurement</b> .....	14-7
Blowby Conversion Chart (5.613 mm [0.221 in] Orifice).....	14-7
<b>Chassis Dynamometer - Operation</b> .....	14-20
<b>Engine - Painting</b> .....	14-28
<b>Engine Dynamometer Test - Engine Run-In</b> .....	14-14
<b>Engine Dynamometer Test - Performance Checking</b> .....	14-18
<b>Engine Dynamometer Test - Installation of the Engine</b> .....	14-8
<b>Engine Run-In Procedure - (Chassis Dynamometer)</b> .....	14-25
<b>Engine Run-In Procedure "In Chassis" - (On- and Off-Highway Vehicles)</b> .....	14-27
Off-Highway .....	14-27
On-Highway .....	14-27
<b>Engine Storage - Long Term</b> .....	14-31
Removing the Engine from Long-Term Storage .....	14-34
<b>Engine Storage - Short Term</b> .....	14-29
Removing the Engine from Short-Term Storage .....	14-31
<b>Engine Testing - Engine Side Views</b> .....	14-4, 14-5
<b>Engine Testing - General Information</b> .....	14-6
General Engine Test Specifications.....	14-6
<b>Engine Testing - Service Tools</b> .....	14-2
<b>General Engine Test Procedures - (Chassis Dynamometer)</b> .....	14-22

## Engine Testing - Service Tools

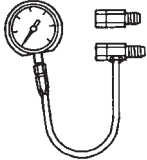
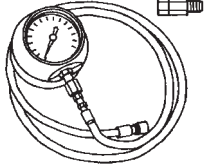
The following special tools are recommended to perform procedures in Group 14. The use of these tools is shown in the appropriate procedure. These tools can be purchased from your local Cummins Authorized Repair Location.

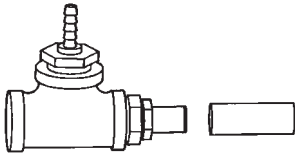
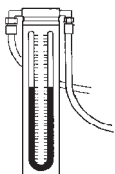
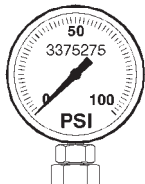
Tool No.	Tool Description	Tool Illustration
ST-434	<p><b>Vacuum Gauge</b> Check the fuel filter restriction during the engine performance test. Hose Adapter, Part No.ST-434-2, and vacuum gauge, Part No.ST-424-12, are used to perform the test.</p>	 <p style="text-align: right; font-size: small;">eg8togc</p>
ST-1273	<p><b>Pressure Gauge</b> Use to measure the engine intake manifold pressure.</p>	 <p style="text-align: right; font-size: small;">eg8togi</p>
3375049	<p><b>Oil Filter Wrench</b> Use to remove or tighten spin-on lubricating oil or fuel filters.</p>	 <p style="text-align: right; font-size: small;">1f8togb</p>
3822476	<p><b>Blowby Checking Tool</b> Use to check engine crankcase blowby.</p>	 <p style="text-align: right; font-size: small;">eg8toge</p>
ST-1111-3	<p><b>Water Manometer</b> Used with the blowby check tool to measure engine crankcase pressure.</p>	 <p style="text-align: right; font-size: small;">eg8toga</p>
3375275	<p><b>Pressure Gauge (0-160 psi)</b> Used to measure lubricating oil pressure.</p>	 <p style="text-align: right; font-size: small;">3375275</p>

3375275

Tool No.	Tool Description	Tool Illustration
3377462	<b>Digital Optical Tachometer</b> Used to measure engine speed (RPM).	 <small>3377462</small>

### Engine Testing - Engine Side Views

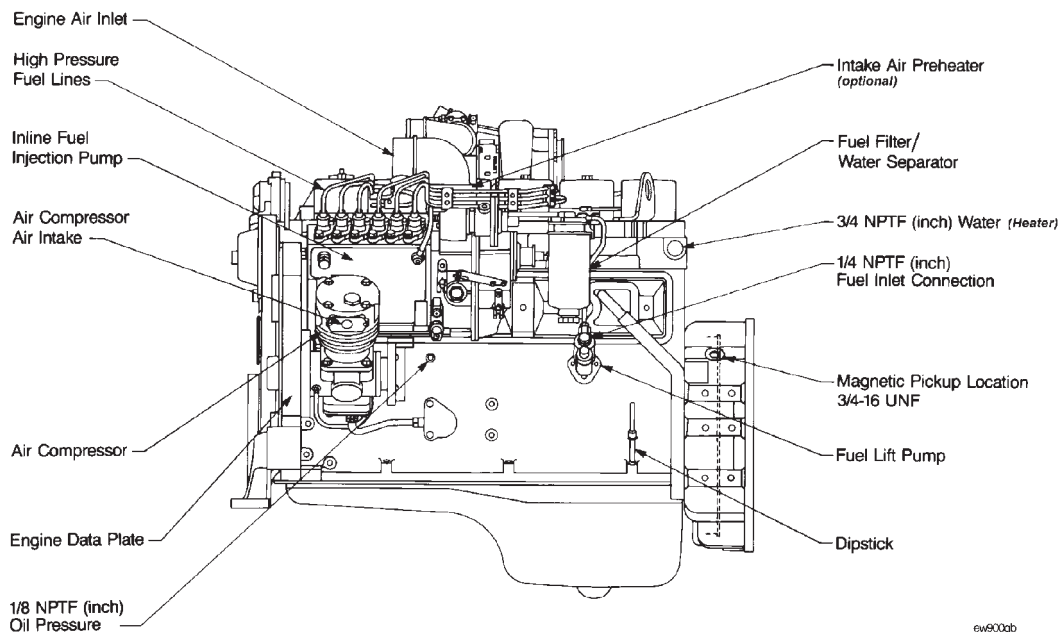

Fuel Pump Side

### Engine Testing - Engine Side Views

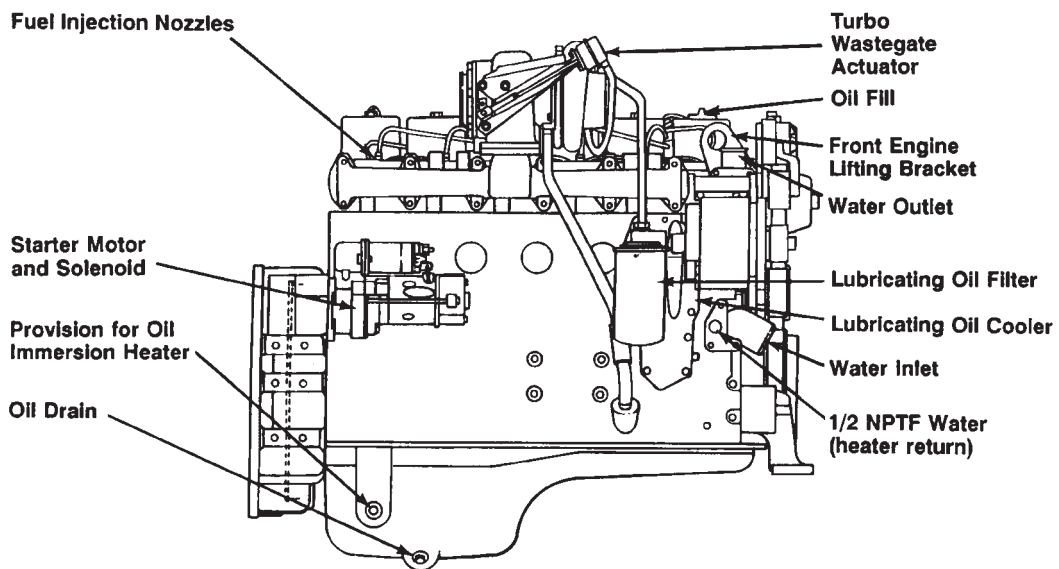

**Turbocharger Side View**

ew900gc

Exhaust Side

## Engine Testing - General Information

The engine test is a combination of an engine run-in and a performance check. The engine run-in procedure provides an operating period that allows the engine parts to achieve a final finish and fit. The performance check provides an opportunity to perform final adjustments needed to optimize the engine performance.

An engine test can be performed using **either** an engine dynamometer **or** a chassis dynamometer. If a dynamometer is **not** available, an engine test **must** be performed in a manner that simulates a dynamometer test.

Check the dynamometer before beginning the test. The dynamometer **must** have the capability to test the performance of the engine when the engine is operating at the maximum RPM and horsepower range (full power).

The engine crankcase pressure, often referred to as engine blowby, is an important factor that indicates when the piston rings have achieved the correct finish and fit. Rapid changes of blowby or values that exceed specifications more than 50 percent indicate that something is wrong. The engine test **must** be discontinued until the cause has been determined and corrected.

### General Engine Test Specifications

Maintain the following limits during a chassis dynamometer test:

#### Intake Restriction (Maximum)

- Clean Filter (light duty).....254 mm H<sub>2</sub>O [10 in. H<sub>2</sub>O]  
(medium duty) .....305 mm H<sub>2</sub>O [12 in. H<sub>2</sub>O]  
(heavy duty).....381 mm H<sub>2</sub>O [15 in. H<sub>2</sub>O]
- Dirty Filter (light duty).....635 mm [25 in.]  
(medium duty).....635 mm [25 in.]  
(heavy duty).....635 mm [25 in.]

#### Exhaust Back Pressure (maximum)

- Industrial ..... 76 mm Hg [3.0 in.Hg]
- EPA Certified.....114 mm Hg [4.5 in. Hg]
- Oxidation Catalyst.....152 mm Hg [6.0 in Hg]

#### Blowby\*\* (at Given Speed, 100% Load)

	New (L/Min)	Worn (L/Min)
4B @ 2200	18	36
4B @ 2500	20	40
4B @ 2800	23	46
4BT/4BTA/B3.9 @ 2200	45	90
4BT/4BTA/B3.9 @ 2500	51	102
4BT/4BTA/B3.9 @ 2800	57	114
6B @ 2200	26	52
6B @ 2500	30	60
6B @ 2800	34	68
6BT/6BTA/B5.9 @ 2200	63	126
6BT/6BTA/B5.9 @ 2500	76	152
6BT/6BTA/B5.9 @ 2800	85	170

\*\*Blowby checking tool, Part No. 3822476, has a special 5.613 mm [0.221 in.] orifice that **must** be used to get an accurate reading.

#### Oil Pressure

- Low Idle (minimum allowable) ..... 69 kPa [10 psi]
- Rated Speed (minimum allowable) ..... 207 kPa [30 psi]

#### Fuel Filter Restriction (Maximum pressure drop across filter)

- Dirty Filter ..... 35 kpa [5 psi]

Fuel Return Restriction (Maximum) ..... 518 mm Hg [20.4 in hg]

**NOTE:** Due to variations in ratings of different engine models, refer to the specific engine data sheet for the particular engine model being tested.

### Blowby Measurement

Blowby is generally recorded in liters/minute, but a water manometer may be used to measure blowby from the breather tube after fabricating the following adaptation:

1. Plug the end of the straight portion of a pipe tee.
2. Drill an orifice in the plug (refer to the Blowby Conversion Chart below for the appropriate orifice size).
3. Connect the open straight portion of the pipe tee to the breather tube.
4. Connect a water manometer to the 90 degree outlet.
5. Use the Blowby Conversion Chart to convert the manometer reading to liters/minute.

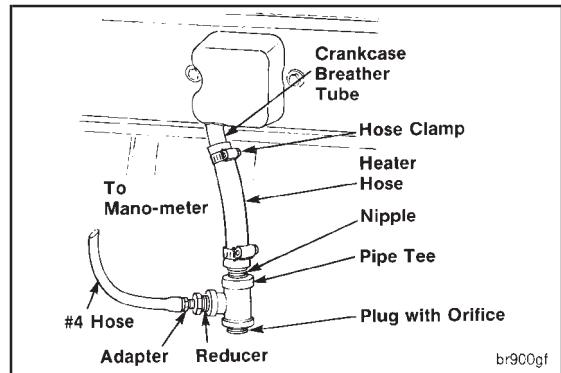

**Blowby Conversion Chart (5.613 mm [0.221 in] Orifice)**

Inches of Water	Liters/Minute	Inches of Water	Liters/Minute
1	27	19	121
2	40	20	124
3	49	21	128
4	58	22	131
5	64	23	135
6	71	24	137
7	76	25	140
8	81	26	144
9	86	27	147
10	90	28	150
11	94	29	154
12	98	30	157
13	102	31	160
14	105	32	163
15	109	33	166
16	112	34	169
17	115	35	172
18	118		

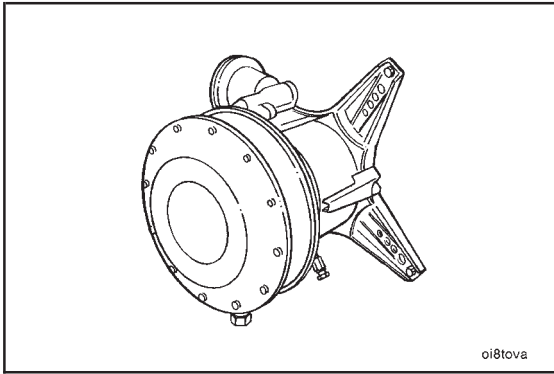

### Engine Dynamometer Test - Installation of the Engine (14-01)

Use engine lifting fixture, Part No. ST-125, to install the engine to the test stand. Align and connect the dynamometer. Refer to the manufacturer's instructions for aligning and testing the engine.

**NOTE:** Make sure the dynamometer capacity is sufficient to permit testing at 100 percent of the engine rated horsepower. If the capacity is **not** enough, the testing procedure **must** be modified to match the restrictions of the dynamometer.

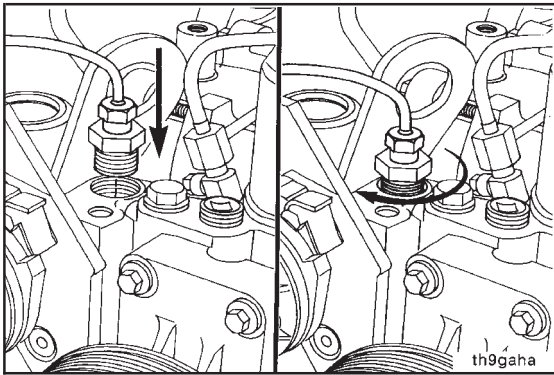

Install the coolant temperature sensor.

**Minimum Gauge Capacity:** 107°C [225°F]

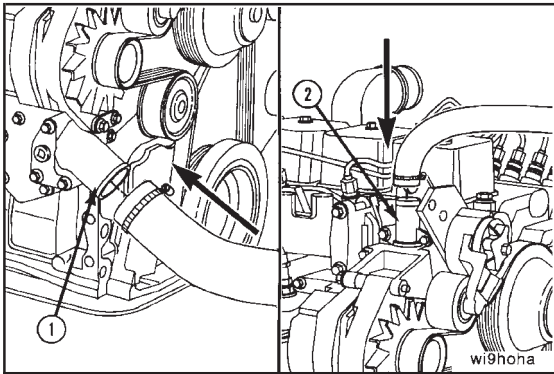

Connect the coolant supply to the water inlet connection (1).

Connect the coolant return to the water outlet connection (2).

Install the drain plugs, close all the water drain cocks, and make sure all the clamps and fittings are tight.

Connect the vent tube to the vent connection on the thermostat housing.

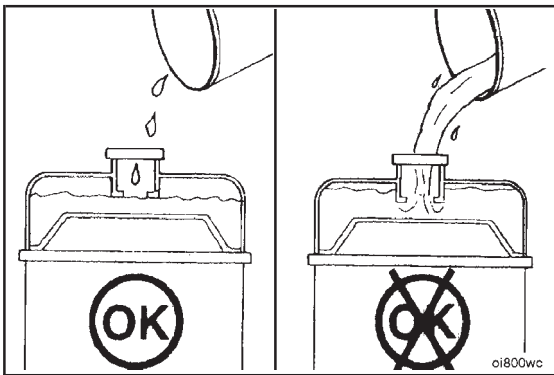

Fill the cooling system with coolant to the bottom of the fill neck in the radiator fill (or expansion) tank.

**NOTE:** Maximum Fill Rate is 14 Liters/min [3.5 U.S. gallons/min]



Inspect the engine for coolant leaks at connections, fittings, plates, and plugs. Repair as necessary.

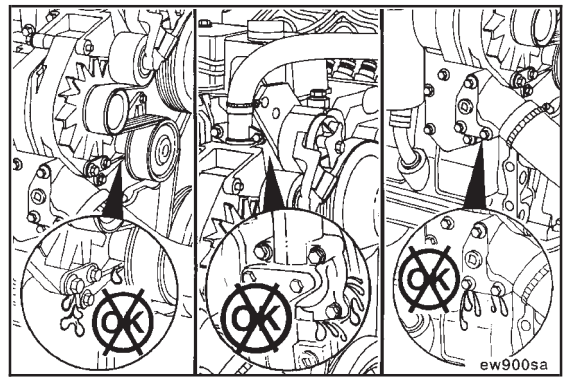

Connect a water manometer to the turbocharger air inlet pipe to test air restriction.



**NOTE:** The manometer connection **must** be installed at a 90 degree angle to the air flow in a straight section of pipe, one pipe diameter before the turbocharger.

**NOTE:** A vacuum gauge can be used in place of the water manometer.

**Minimum Gauge Capacity:** 760 mm H<sub>2</sub>O [30 in. H<sub>2</sub>O]

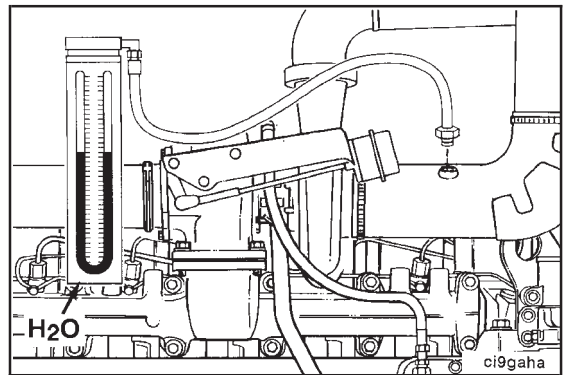

Connect a mercury manometer to a straight section of the exhaust piping near the turbocharger outlet to check exhaust restriction.



**NOTE:** A pressure gauge can be used in place of the mercury manometer.

**NOTE:** For automotive applications, a tapped hole is provided on the inlet side of the catalyst to check exhaust restriction.

**Minimum Gauge Capacity:** 254 mm Hg. [10 in. Hg.]

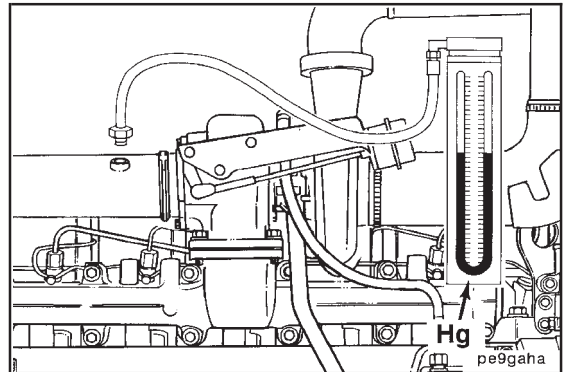

Attach the lubricating oil temperature sensor in one of the locations on the side of the engine as shown.



**Minimum Gauge Capacity:** 150°C [300°F]

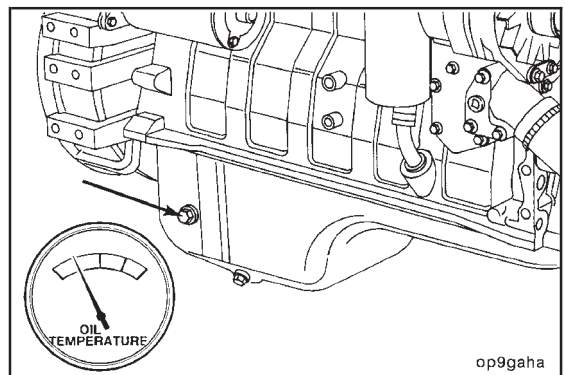

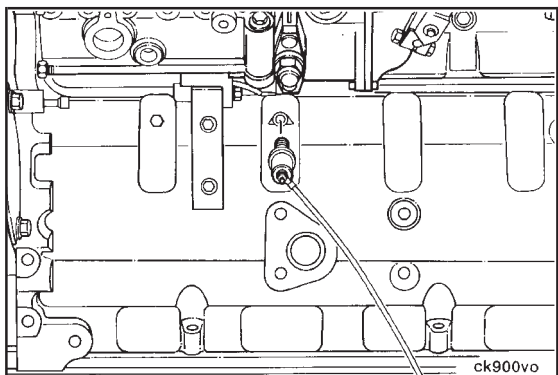

Attach the lubricating oil pressure sensor to the main oil rifle drilling in the cylinder block.

**Minimum Gauge Capacity:** 1034 kPa [150 psi]

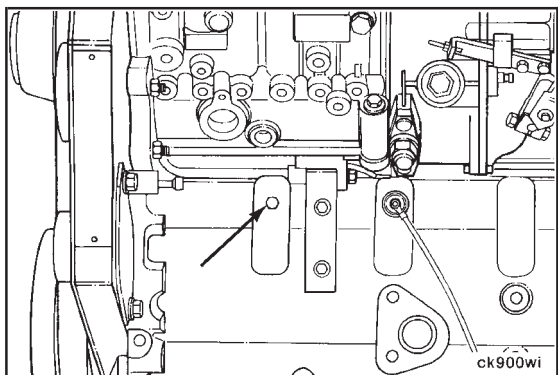

**Caution:** The lubricating oil system must be primed before operating the engine after it has been rebuilt to avoid internal damage. Do not prime the system from the bypass filter head if an external pressure pump is used. Damage to the bypass filter will result.



To prime the system using external pressure, connect the supply to the tapped hole in the main oil rifle.

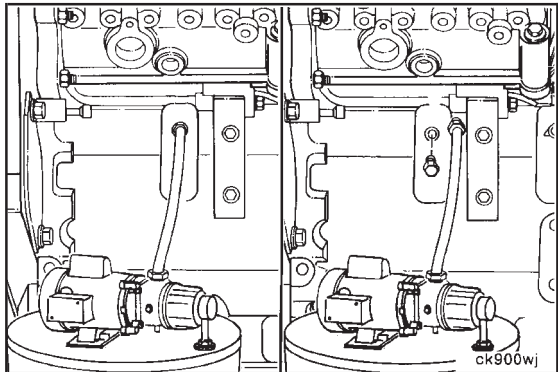

Use a pump capable of supplying 210 kPa [30 psi] continuous pressure. Connect the pump to the port on the main oil rifle as shown.

Use clean 15W-40 oil to prime the system until the oil pressure registers on the gauge.

Remove the oil supply tube, and install the plug.

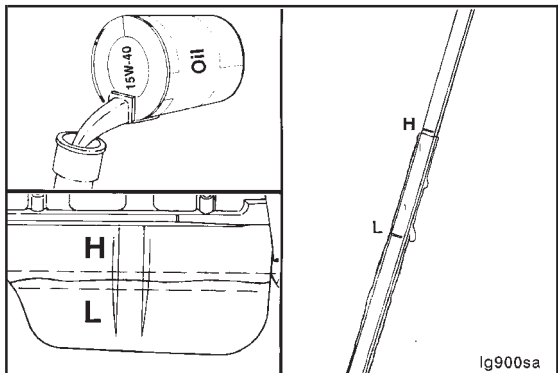

Make sure the lubricating oil has had time to drain to the pan, and fill the engine to the high mark as measured on the dipstick.

If an external pressure pump is **not** available, prime the lubricating system according to the following procedure.  
Fill the engine with oil to the high level mark on the dipstick.

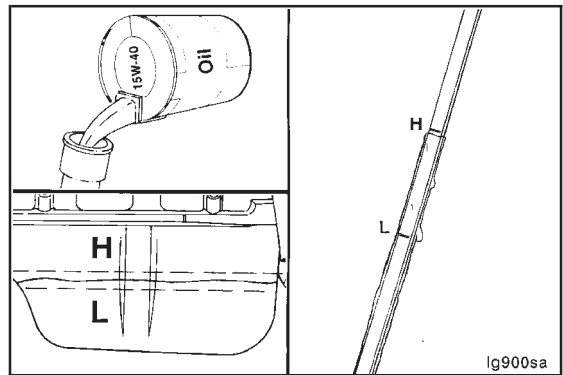

Disconnect the turbocharger lubricating oil supply tube.  
Pour 50 cc to 60 cc [2.0 fl.oz. to 3.0 fl.oz.] of clean 15W-40 oil into the turbocharger oil supply hole.  
Connect the oil supply tube to the turbocharger.

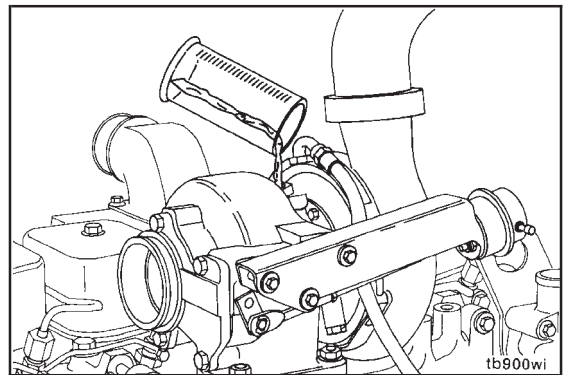

**Caution: Mechanical over-tightening can distort the threads or damage the filter element seal.**  
Fill the lubricating oil filter with clean 15W-40 oil.  
Screw the filter onto the filter head fitting until the gasket contacts the filter head surface.  
Tighten the filter according to the manufacturer's specifications.

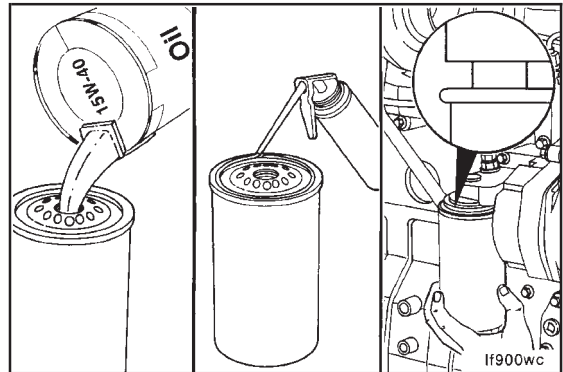

To make sure the lubricating oil pump is providing adequate oil to the engine, first disconnect any wires leading to the fuel pump solenoid.

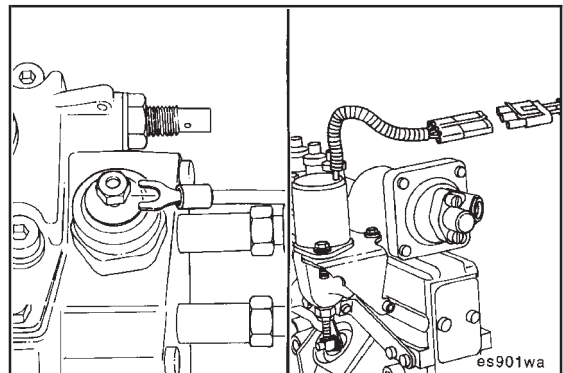

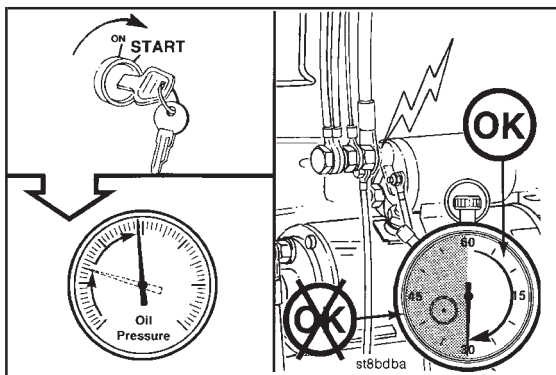

**Caution:** Do not crank the starting motor for periods longer than 30 seconds. Excessive heat will damage the starting motor.

Crank the engine until the oil pressure gauge indicates system pressure.

**NOTE:** Allow 2 minutes between the 30-second cranking periods so the starting motor can cool.

**NOTE:** If pressure is **not** indicated, find and correct the problem before continuing.

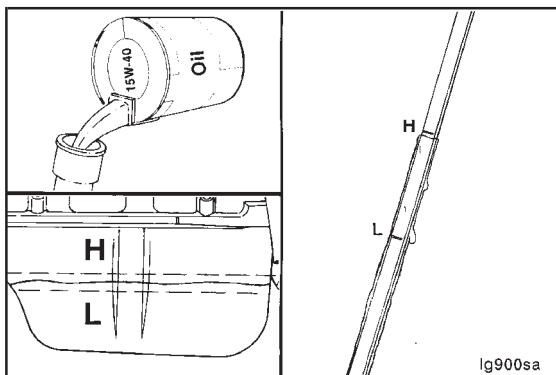

Allow the lubricating oil to drain into the oil pan, and measure the oil level with the dipstick.

Add oil as necessary to bring the level to the high level mark.

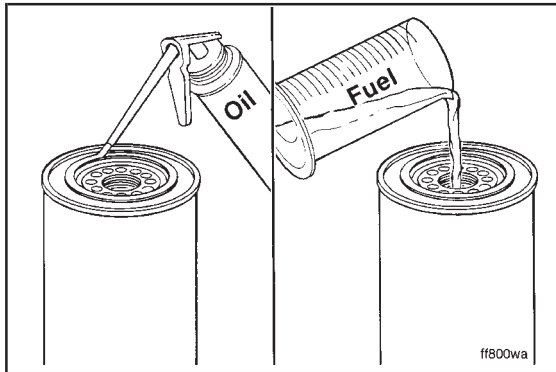

Lubricate the gasket on the fuel filter with clean 15W-40 oil.

Fill the fuel filter with clean fuel.

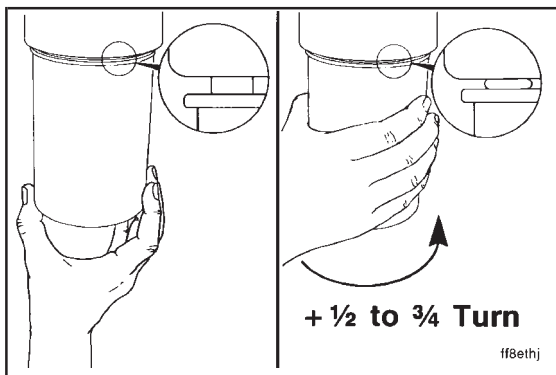

Screw the fuel filter onto the filter head until the gasket contacts the filter head surface.

Tighten the filter an additional 1/2 to 3/4 turn.

Make sure the voltage supply matches that of the fuel pump solenoid before connecting the electrical wires to it.

Attach the throttle control rod onto the fuel pump throttle lever.

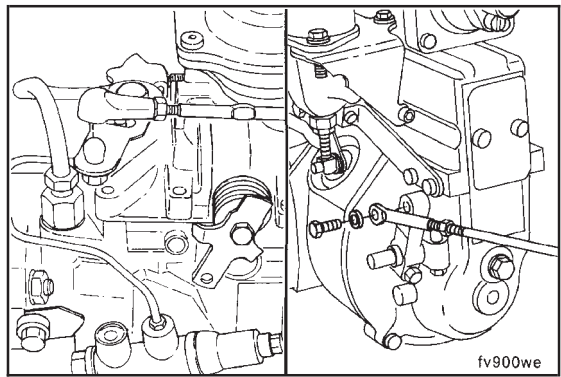

**ST-1273**

To determine the amount of turbocharger boost and aftercooler/charge air cooler restriction install intake manifold pressure gauges, Part No. ST-1273 in the turbocharger outlet and the intake manifold.

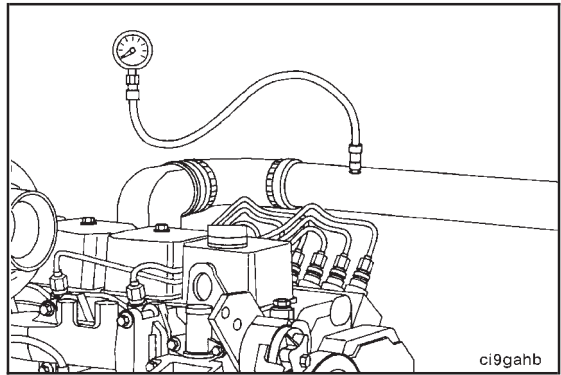

**Part No. 3822676**

For accurate engine crankcase blowby measurement, insert a blowby checking tool in the crankcase breather vent.

Connect a water manometer to the blowby tool Part No. 3822676. A pressure gauge can be used in place of the manometer.

**Minimum Gauge Capacity:** 1270 mm H<sub>2</sub>O [50 in. H<sub>2</sub>O]

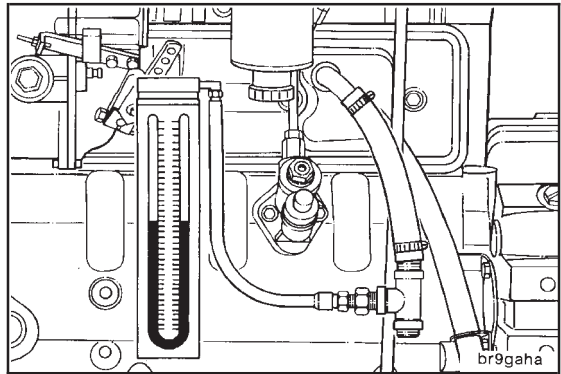

**Part No. ST-434**

To measure fuel filter restriction, connect vacuum gauge, Part No. ST-434, to the injection pump inlet line.

**Minimum Gauge Capacity:** 760 mm Hg [30 in. Hg]

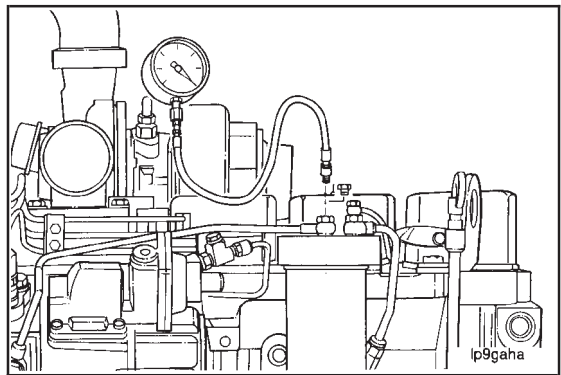

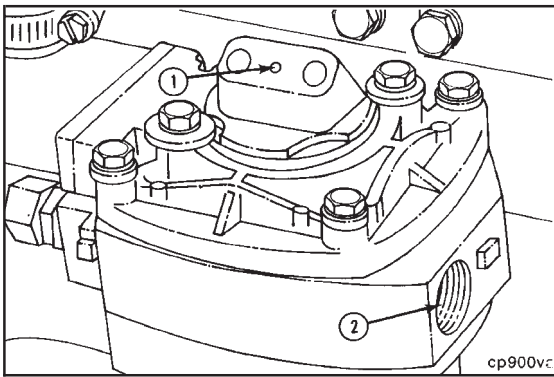

To be able to unload the compressor, connect a source of compressed air to the unloader (1). This air line **must** contain a valve between the source and the unloader.

**NOTE:** All air compressors manufactured by Cummins Engine Company, Inc. **must** be **loaded** during engine run-in. All air compressors **must** be **unloaded** during the engine performance check.

**NOTE:** The compressed air load in the accompanying illustration **must** be attached to the air compressor outlet (2).

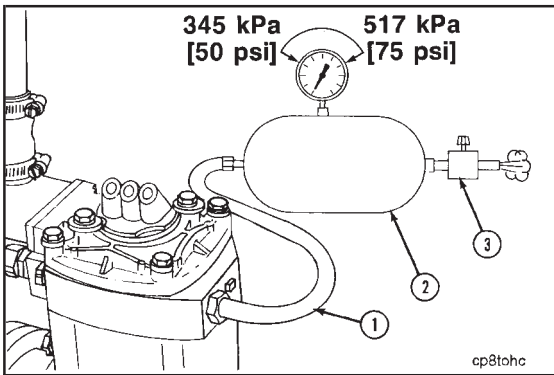

To provide a load on the air compressor, connect an air tank to the compressor outlet (2), using steel tubing or a high temperature hose (1).

Install an air regulator (3) that can maintain tank air pressure of 345 kPa to 517 kPa [50 psi to 75 psi] at both the minimum and the maximum engine RPM.

**Hose Temperature (Minimum):** 260°C [500°F]

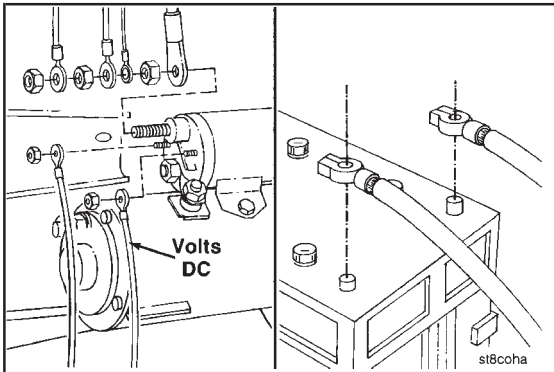

Inspect the voltage rating on the starting motor before installing the electrical wiring.



Attach electrical wires to the starting motor and the batteries, if used.



**NOTE:** If another method of starting the engine is used, follow the manufacturer's instructions to make the necessary connections.

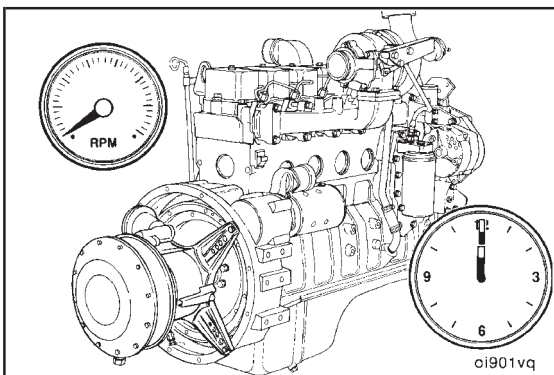

### Engine Dynamometer Test - Engine Run-In (14-02)

The engine run-in period allows the tester to detect assembly errors and to make final adjustments needed for performance that meets specifications.

**NOTE:** The amount of time specified for the following engine run-in phases are minimums. Additional time can be used at each phase **except** engine idle periods, if so desired.

Measurements from these indicators and gauges **must** be observed closely during all phases of the engine run-in period. Refer to page 14-6 for specifications and acceptable readings.

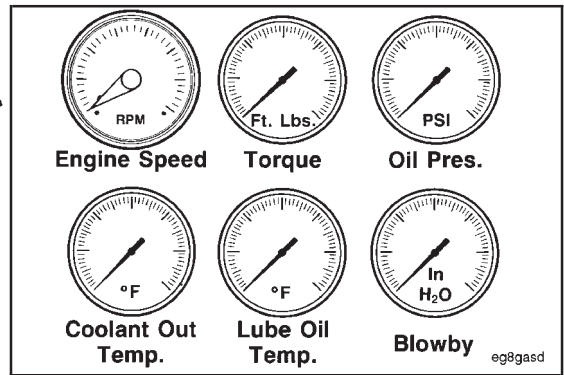

To correctly evaluate the engine performance, this additional measurement **must** be observed during engine run-in phases.

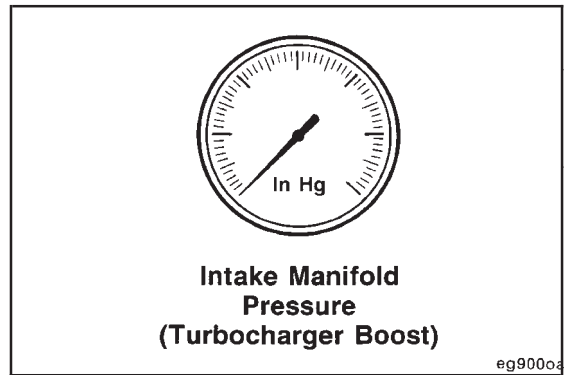

It is good practice to observe these measurements even if engine performance meets specifications. If engine performance does **not** meet specifications, these measurements can indicate possible reasons for under-performance.

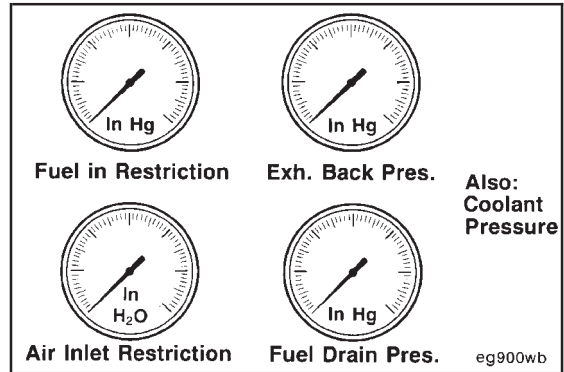

**Caution:** Do not crank the engine for more than 30 seconds. Excessive heat will damage the starting motor.



Crank the engine and observe the oil pressure when the engine starts. If the engine fails to start within 30 seconds, allow the starting motor to cool for 2 minutes before cranking the engine again.

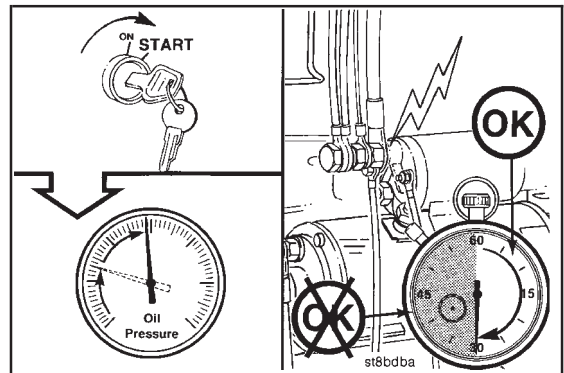

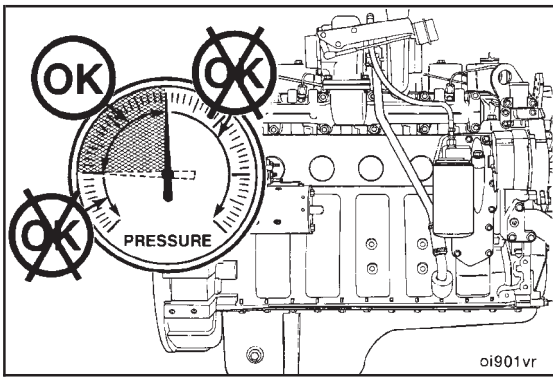

**Caution:** If the lubricating oil pressure is not within specifications, shut off the engine immediately. Either excessively low or excessively high oil pressure will cause engine damage.

Engine oil pressure **must** be at least 69 kPa [10 psi] at 700 RPM.

Correct the problem if the oil pressure is **not** within specifications.

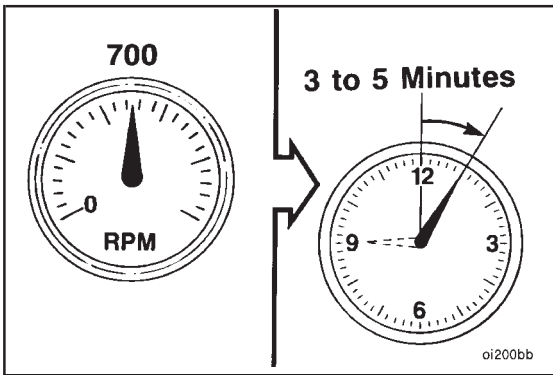

**Caution:** Do not operate the engine at idle speed longer than specified during engine run-in. Excessive carbon formation will cause damage to the engine.

Operate the engine at approximately 700 RPM for 3 to 5 minutes.

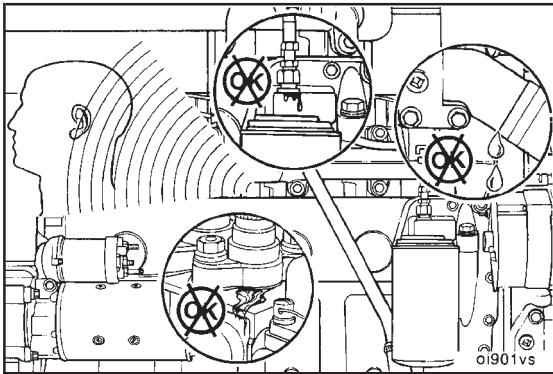

Listen for unusual noises; watch for coolant, fuel, and lubricating oil leaks; and check for correct engine operation in general.

**NOTE:** Repair all leaks or component problems before continuing the engine run-in.

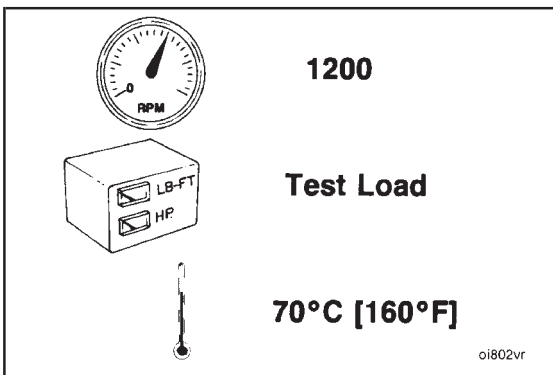

Move the throttle to obtain 1,200 RPM engine speed, and set the test load to 25 percent of the torque peak load.

Operate the engine at this speed and load level until the coolant temperature is 70°C [160°F]. Check all gauges and record the data.

**NOTE:** Do **not** proceed to the next step until a steady blowby reading is obtained.



Operate the engine at this speed and load level for 2 minutes.

Check all gauges and record the data.

**NOTE:** Do **not** proceed to the next step until blowby is stable and within specifications.



**Torque Peak**  
**2x (Test Load)**  
**(50% Rated Load)**  
**2 Minutes**

oi804vh

Maintain the engine speed at torque peak RPM, increase the dynamometer load to 75 percent of torque peak load. Operate the engine at this speed and load level for 2 minutes. Check all gauges and record the data.

**NOTE:** Do **not** proceed to the next step until blowby is stable and within specifications.



**Torque Peak**  
**3x (Test Load)**  
**(75% Rated Load)**  
**2 Minutes**

oi804vi

Move the throttle lever to its fully opened position, and increase the dynamometer load until the engine speed is at torque peak RPM. Operate the engine at this speed and load level for 10 minutes or until the blowby becomes stable and within specifications.

Check all gauges and record the data.



**Full Throttle**  
**Torque Peak**  
**Maximum Load**  
**10 Minutes**

oi804vj

Reduce the dynamometer load until the engine speed increases to the engine's rated RPM.

Operate the engine at rated RPM for 5 minutes.

Check all gauges and record the data.



**Full Throttle**  
**Rated**  
**Maximum Load**  
**at Rated Speed**  
**5 Minutes**

oi804vk

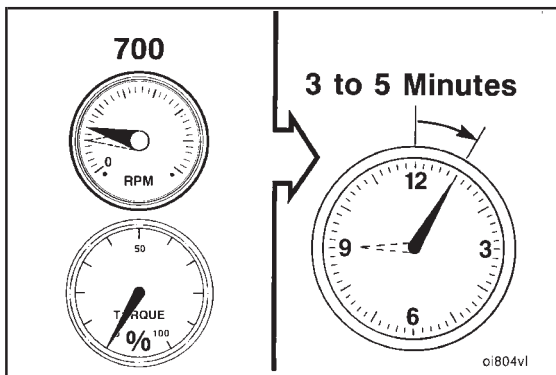

**Caution:** Shutting off the engine immediately after operating at full load will damage the turbocharger and internal components. Always allow the engine to cool before shutting it off.

Remove the dynamometer load completely, and operate the engine at 700 RPM for 3 to 5 minutes. This period will allow the turbocharger and other components to cool.

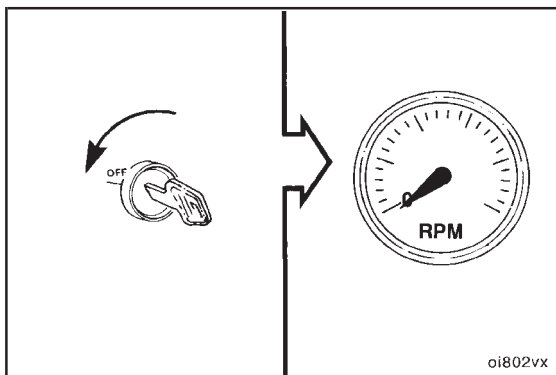

Shut off the engine.

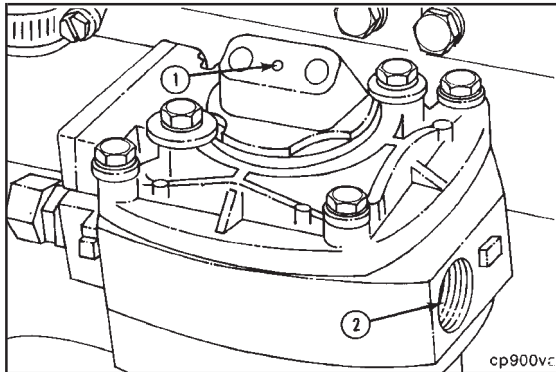

**Engine Dynamometer Test - Performance Checking (14-03)**

Make sure the air compressor will be unloaded during the performance check.

Apply regulated air pressure of 655 kPa [95 psi] to the air compressor unloader (1).

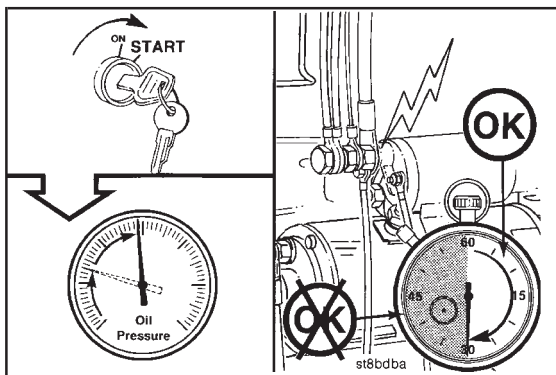

**Caution:** Do not crank the engine for more than 30 seconds. Excessive heat will damage the starting motor.

Crank the engine and observe the oil pressure when the engine starts. If the engine fails to start within 30 seconds, allow the starting motor to cool for 2 minutes before cranking the engine again.

**Caution:** If the lubricating oil pressure is not within specifications, shut off the engine immediately. Either excessively low or excessively high oil pressure will cause engine damage. Correct the problem if oil pressure is not within specifications.

Engine oil pressure **must** be a minimum of 69 kPa [10 psi] at approximately 700 RPM.

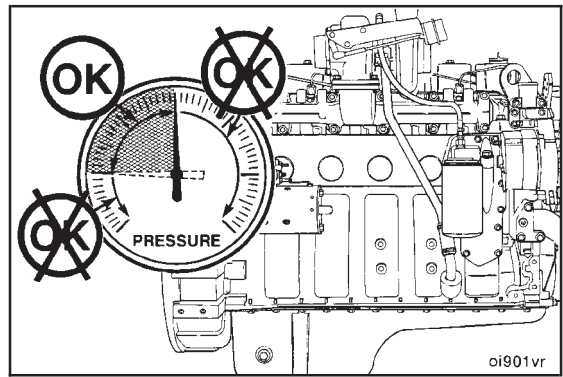

Make sure the engine is at operating temperature.

Move the throttle lever to the "FULL OPEN" position. Adjust the dynamometer load until the engine maintains the rated RPM.

Allow the readings to stabilize. Read the horsepower.

Check all the gauges, and record the readings.

**NOTE:** The horsepower reading will **not** be accurate if the lubricating oil temperature and fuel temperature are **not** within specifications.

**Lubricating Oil Temperature:** MIN 90°C [190°F]

**Fuel Temperature:** MAX 42°C [108°F]

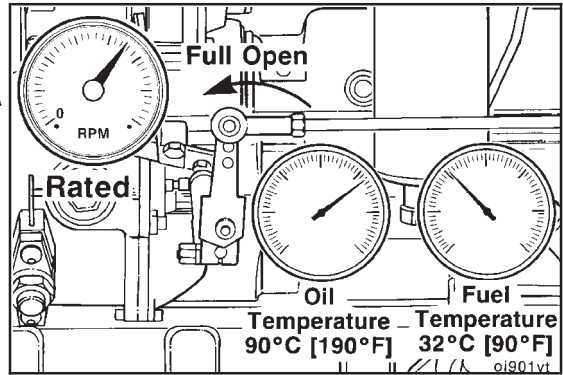

Check all gauges and record the data.

**Caution:** Do not shut off the engine immediately after it has been loaded. It must be allowed to sufficiently cool.

Remove the dynamometer load completely, and operate the engine at idle speed for 3 to 5 minutes. This will allow the turbocharger and other components to cool.

**NOTE:** Idle periods longer than 5 minutes are to be avoided.

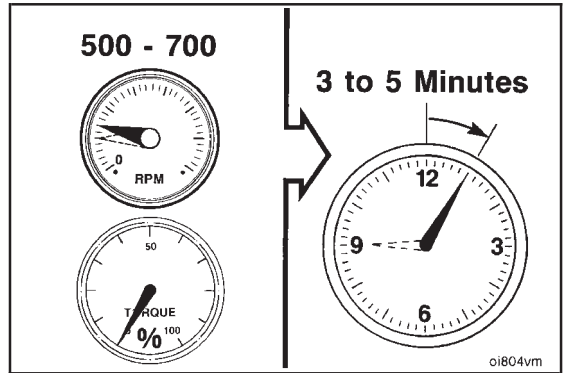

Shut off the engine after the cool-down period.

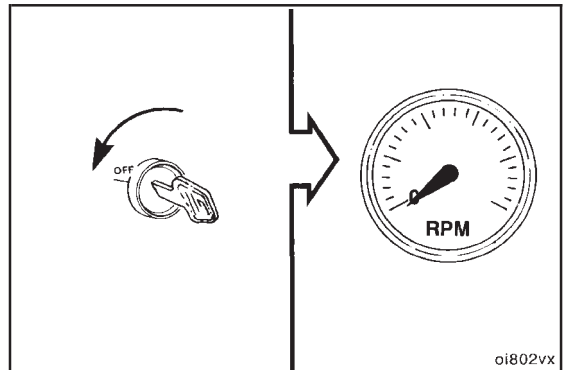

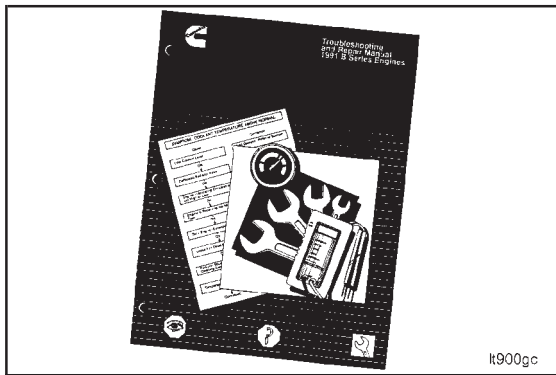

If power specifications are not met, refer to B Series Troubleshooting and Repair Manual, Bulletin No. 3810486.

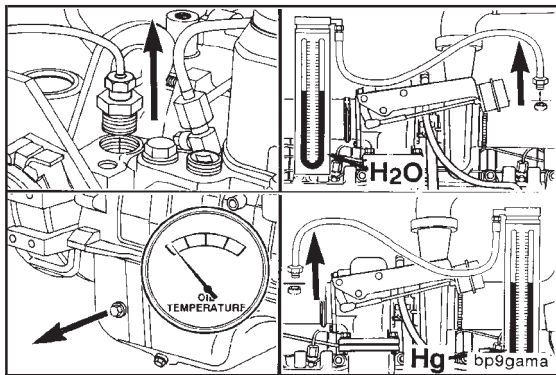

Remove all test instrumentation. Remove the engine from the dynamometer.



**NOTE:** If the engine is to be stored temporarily and does **not** have permanent-type antifreeze, it is necessary to drain all coolant. Drain locations are identified on the engine side views, pages 14-4 and 14-5.



Prepare the engine for Engine Painting (14-08) or Engine Storage (14-09) or (14-10).

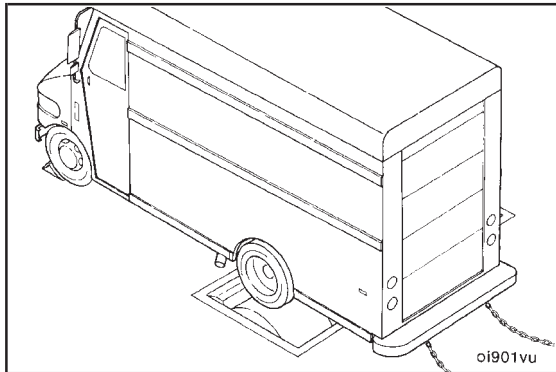

### Chassis Dynamometer - Operation (14-04)

The performance of an engine installed in on-highway vehicles can be tested on a chassis dynamometer.

**NOTE:** Due to driveline efficiency and engine-driven accessories, the engine horsepower when measured at the rear wheels will be reduced by approximately:

- 20 percent for single axle vehicles
- 25 percent for tandem axle vehicles

**NOTE:** These percentages are used for engine run-in only and are **not** to be used as absolute figures.

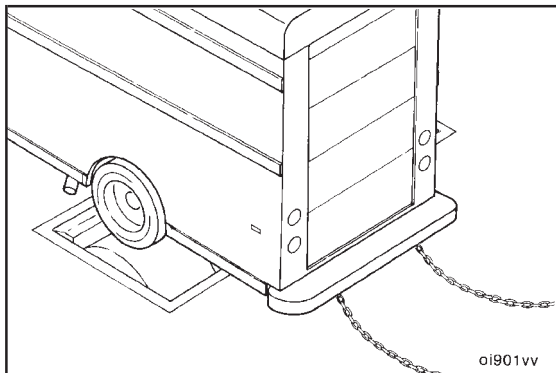

**Caution:** Follow all the vehicle manufacturer's safety precautions before installing or operating a vehicle on a chassis dynamometer.

**Caution:** Low profile radial tires are more sensitive to heat than bias ply tires. Excessive operating time at full load can damage tires due to overheating. Check the tire manufacturer's recommendations for the maximum allowable chassis dynamometer operating time.

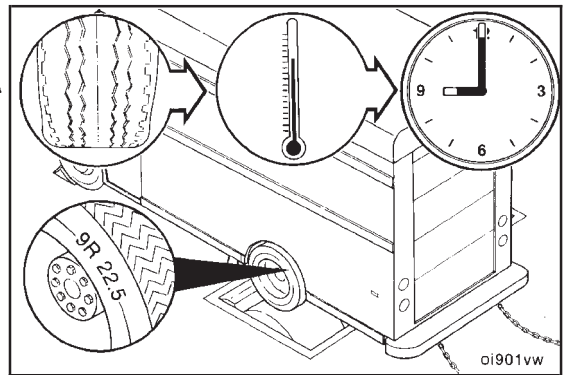

Follow the general safety precautions listed below while operating the chassis dynamometer:

- Use tires that have more than 160 kilometers [100 miles] on them. Do **not** use new tires.
- Do **not** use recapped tires or tires of different sizes or designs.

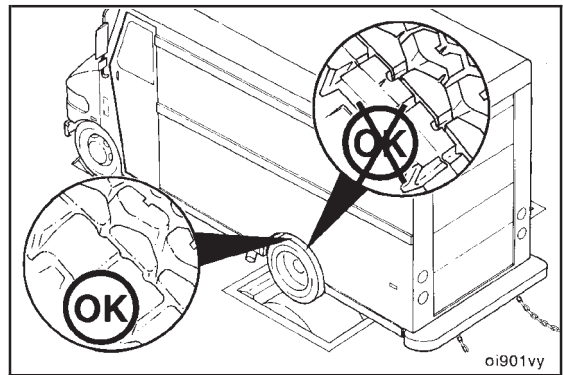

- Make sure the tires are inflated to the manufacturer's specifications.
- Remove all rocks or other material from the tread of all tires that will be rotating on the dynamometer rollers.

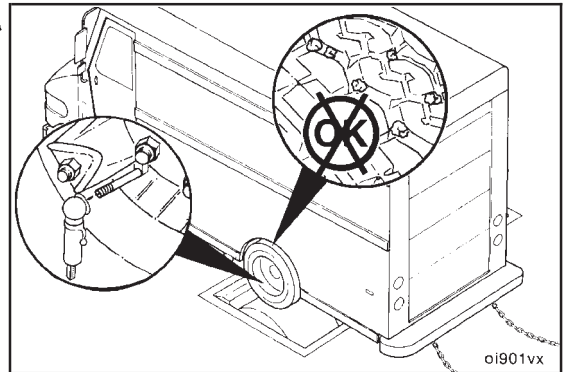

- Make sure there is correct overhead clearance for exhaust stacks, air deflectors, or other attachments above the cab.

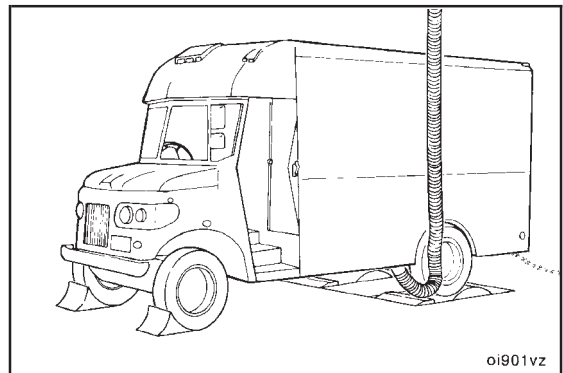

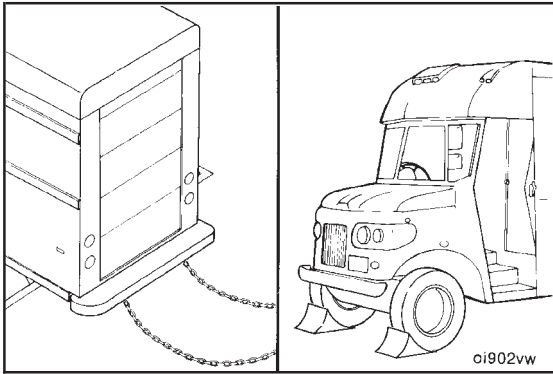

**Caution:** To prevent damage to the chassis dynamometer, there must be some slack in the tension of the tie-down chains.

- Carefully position the vehicle on the rollers.
- Attach the tie-down chains to the rear of the vehicle, and put wheel chocks in front of the front wheels.

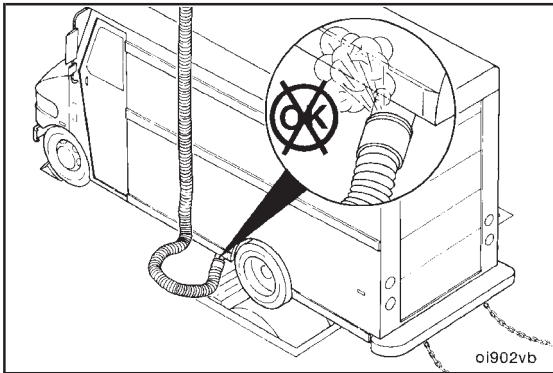

- Adjust the vehicle and dynamometer room exhaust system to make sure all exhaust gases are removed from the room.
- Refer to the chassis dynamometer and vehicle manufacturer's recommendations and specifications for testing procedures.

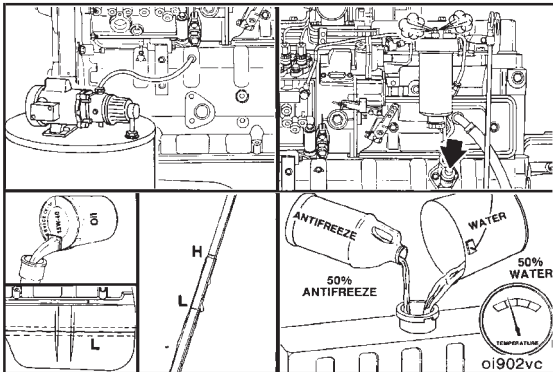

### General Engine Test Procedures - (Chassis Dynamometer) (14-05)

The following procedure assumes that the lubricating oil and fuel systems were correctly primed, the dipstick calibrated, and the engine filled to the correct levels with oil and coolant during installation of the engine into the chassis. If these systems were **not** serviced during installation of the engine, refer to Engine Dynamometer Test - Installation of the Engine (14-01) for instructions on priming the lubricating oil and the fuel systems and calibrating the dipstick. Refer to the latest B Series Operation and Maintenance Manual, Bulletin No. 3810205, for instructions on filling the lubricating oil and the cooling systems.

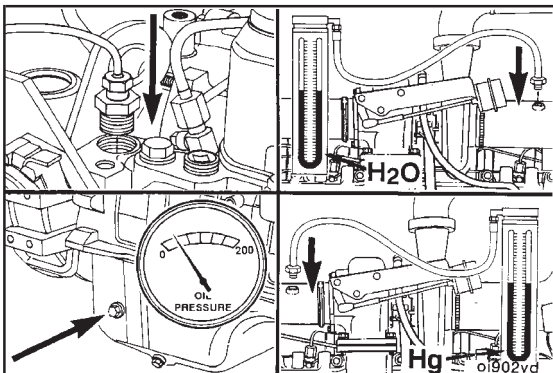

The number of instruments and gauges required to perform a chassis dynamometer test will vary according to the type and the capability of the test equipment used.

Refer to pages 14-4 and 14-5 for the correct system pressure and temperature gauge connecting locations.

To correctly monitor an engine's performance, record the following parameters:

- Lubricating oil pressure (vehicle instrument panel)
- Coolant temperature (vehicle instrument panel)
- Coolant pressure
- Turbocharger outlet pressure
- Exhaust restriction
- Intake manifold pressure
- Inlet air restriction
- Blowby
- Engine speed (RPM) (vehicle instrument panel)
- Wheel horsepower (WHP) (dynamometer controls)

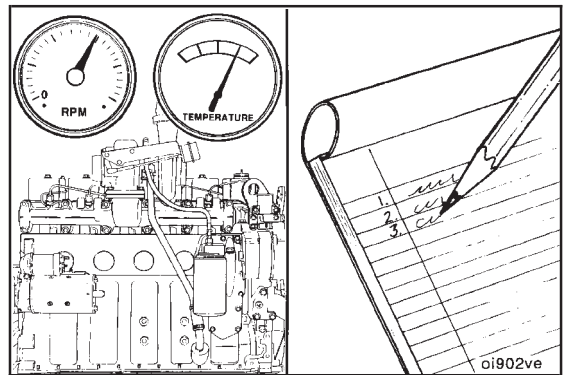

Measure the coolant pressure at the cylinder head, rear fuel pump side.

**Minimum Gauge Capacity:** 415 kPa [60 psi]

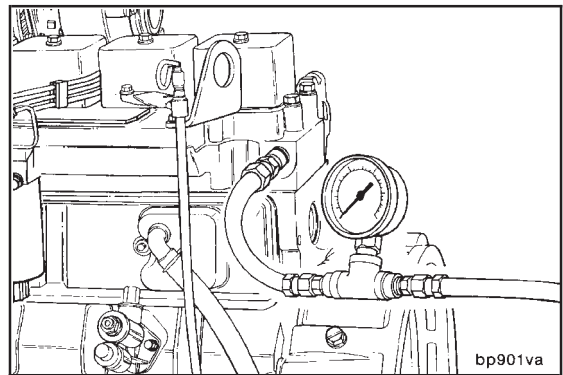

Measure turbocharger outlet pressure and intake manifold pressure. The drop in pressure across the aftercooler/charge air cooler must not exceed 21 kPa [3 psi].

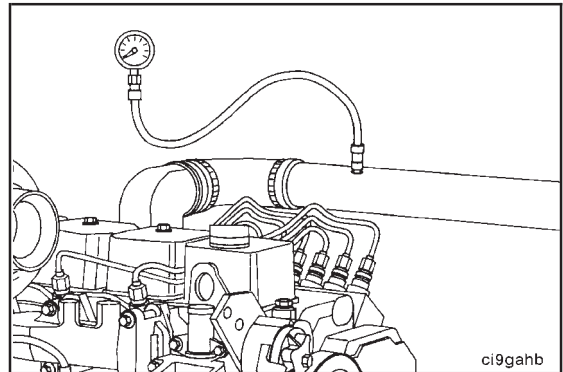

Connect a water manometer to the turbocharger air inlet pipe to test air restriction.

**NOTE:** The manometer connection **must** be installed at a 90 degree angle to the air flow in a straight section of pipe, one pipe diameter before the turbocharger.

**NOTE:** A vacuum gauge can be used in place of the water manometer.

**Minimum Gauge Capacity:** 760 mm H<sub>2</sub>O [30 in. H<sub>2</sub>O]

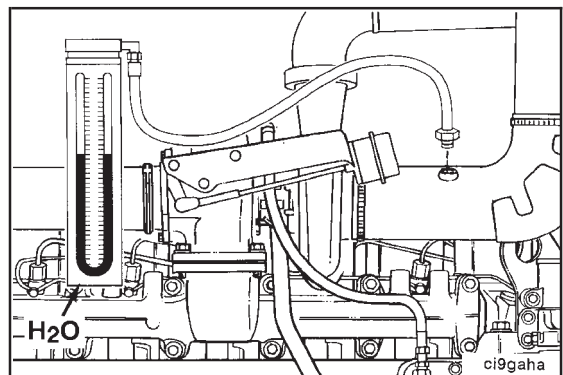

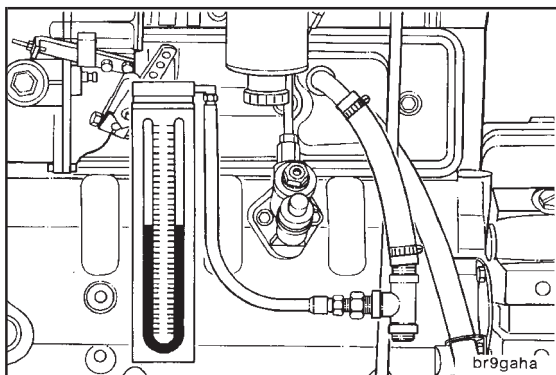

Measure the blowby by installing blowby checking tool in the crankcase breather vent. Connect the blowby tool to a water manometer.



**NOTE:** Excessive blowby indicates a turbocharger malfunction or an engine internal components malfunction, allowing combustion gases to enter the crankcase.



**Minimum Gauge Capacity:** 1270 mm H<sub>2</sub>O [50 in. H<sub>2</sub>O]

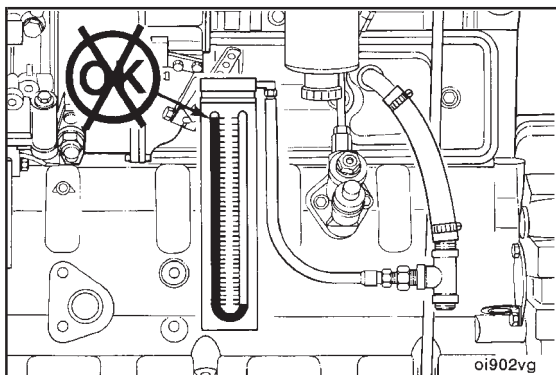

**NOTE:** If a sudden increase in blowby occurs, or if blowby exceeds the maximum allowable limit during any run-in step, return to the previous step and continue the run-in. If blowby does **not** reach an acceptable level, discontinue the run-in and determine the cause.

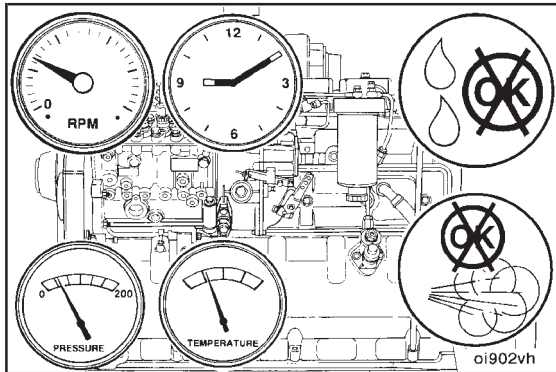

**NOTE:** Avoid long idle periods. Operate the engine at low idle only long enough (3 to 5 minutes) to check for correct oil pressure and any fuel, oil, water, or air leaks.

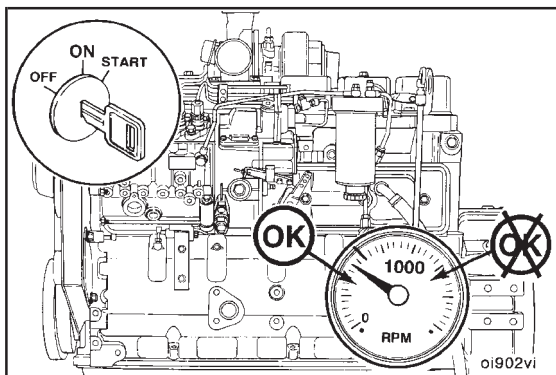

**Caution:** Do not allow the engine speed to exceed 1,000 RPM before run-in. The internal components can be damaged.



**Caution:** Do not shut off the engine immediately after the last step of the run-in is completed. Allow the engine to cool by operating at low idle for a minimum of 3 minutes to avoid internal component damage.

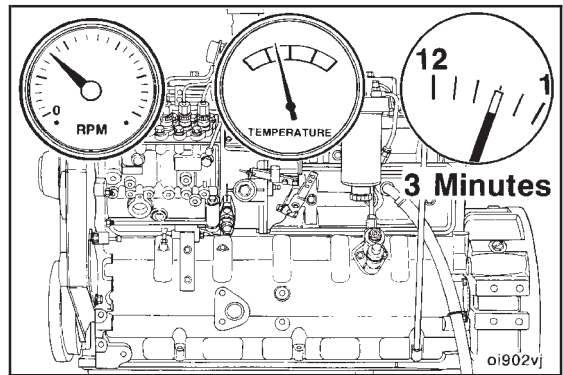

### Engine Run-In Procedure - (Chassis Dynamometer) (14-06)

**Caution:** Refer to General Engine Test Procedures - (Chassis Dynamometer) (14-05) before operating the engine to avoid internal component damage.



**NOTE:** Refer to Chassis Dynamometer Operation on page 14-19 for general operating procedures and safety precautions.

**NOTE:** Operate the vehicle in a gear that produces a road speed of 90 to 95 km/h [ 55 to 60 mph].

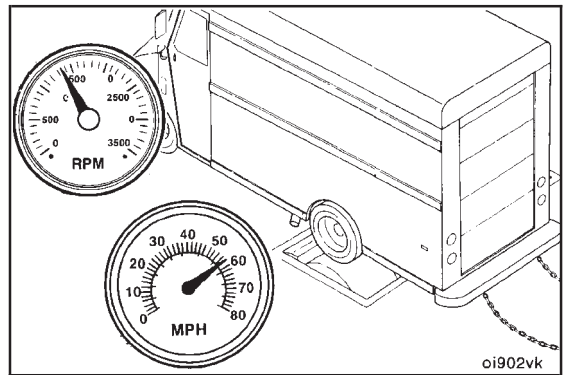

Operate the engine at 1,200 RPM and 25 percent of torque peak load until the water temperature reaches 70°C [160°F].

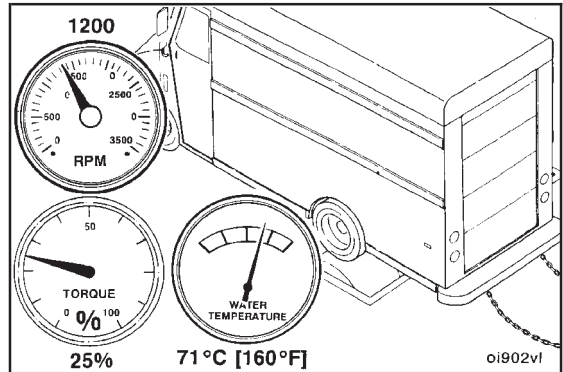

Operate the engine at 1,200 RPM and 40 percent of torque peak load for 2 minutes. Check the gauges, and record the readings.

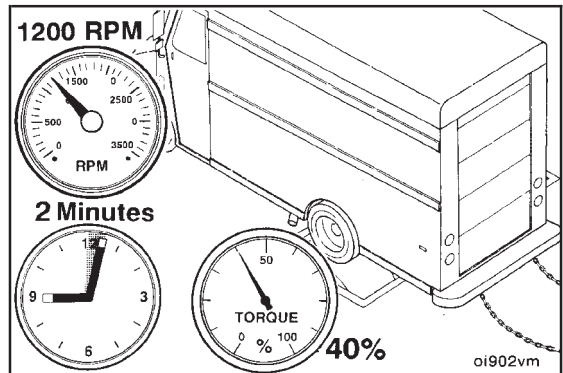

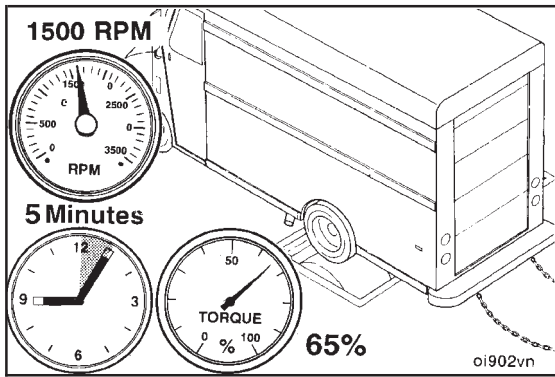

Operate the engine at 1,500 RPM and 65 percent of torque peak load for 5 minutes. Check the gauges, and record the readings.

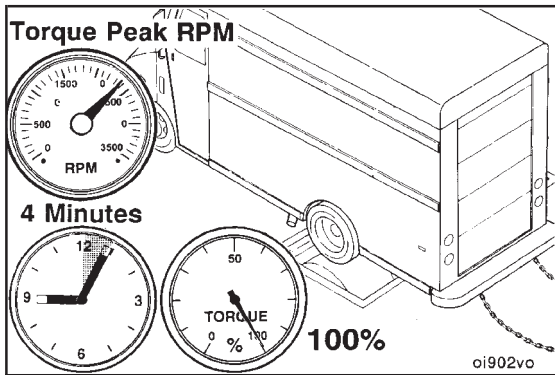

Operate the engine at torque peak RPM and full load for 4 minutes. Check the gauges, and record the readings.

**NOTE:** Refer to the engine data sheet for the torque peak RPM of the engine model being tested.

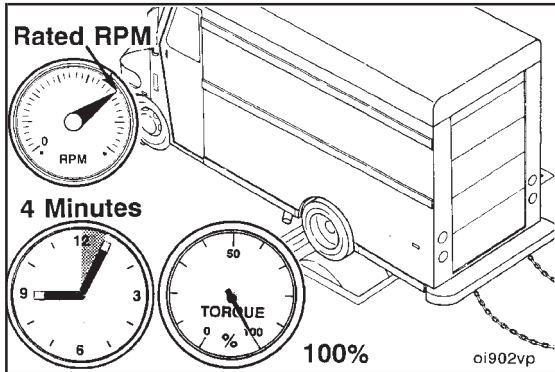

Operate the engine at rated speed (RPM) and full load for 4 minutes. Check the gauges, and record the readings. Compare the readings to those published on the appropriate engine data sheet.



**Caution:** Do not shut off the engine immediately after the run-in is completed. Allow the engine to cool by operating it at low idle for a minimum of 3 minutes to avoid internal component damage.

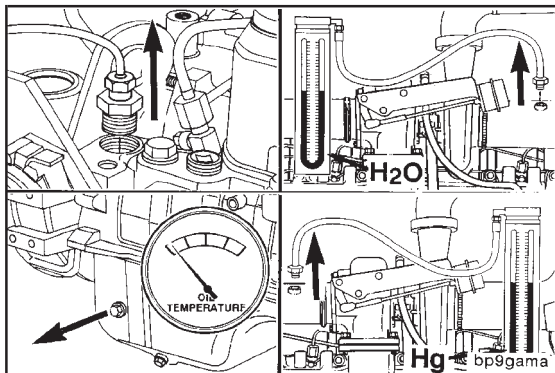

Make sure all instrumentation is removed before removing the vehicle from the dynamometer.

### Engine Run-In Procedure "In Chassis" - (On- and Off-Highway Vehicles) (14-07)

#### On-Highway

**Caution:** Refer to General Engine Test Procedures - (Chassis Dynamometer) (14-05) before operating the engine to avoid internal component damage.



Operate the engine at 1,500 to 1,800 RPM in high gear for the first 80 to 160 kilometers [50 to 100 miles] after rebuild.

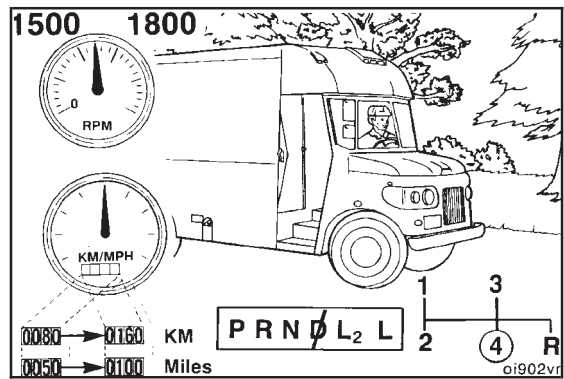

**NOTE:** Do **not** idle the engine for more than 5 minutes at any one time during the first 160 kilometers [100 miles] of operation.

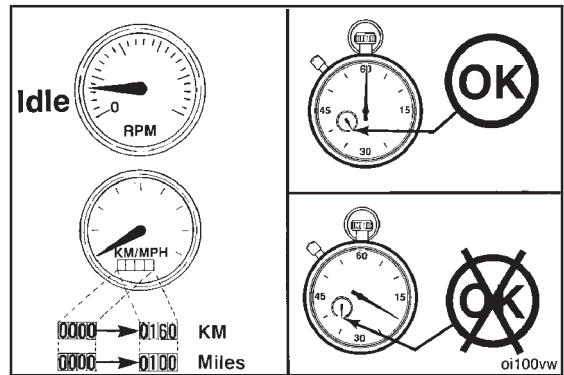

#### Off-Highway

**Caution:** Refer to General Engine Test Procedures - (Chassis Dynamometer) (14-05) before operating the engine to avoid internal component damage.



Operate the engine as follows during the first 3 hours after rebuild:

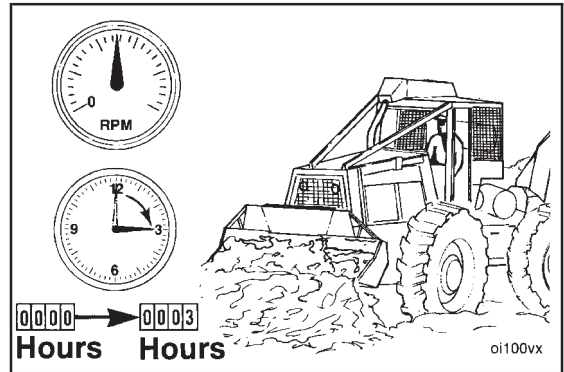

1. Do **not** idle the engine for more than 5 minutes at any one time.
2. Operate the engine at 75 percent throttle while loaded.

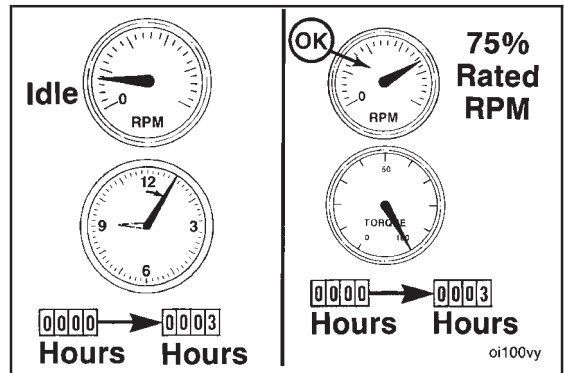

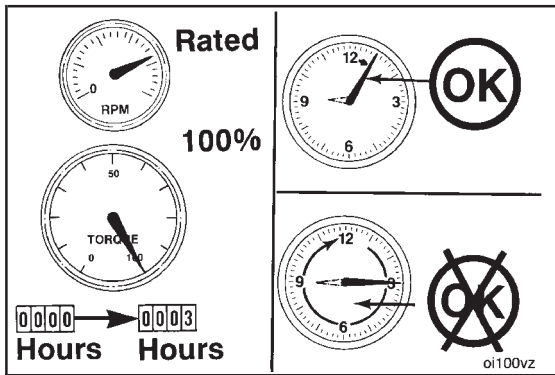

3. Do **not** operate the engine at rated speed (RPM) and full load for more than 5 minutes at any one time.

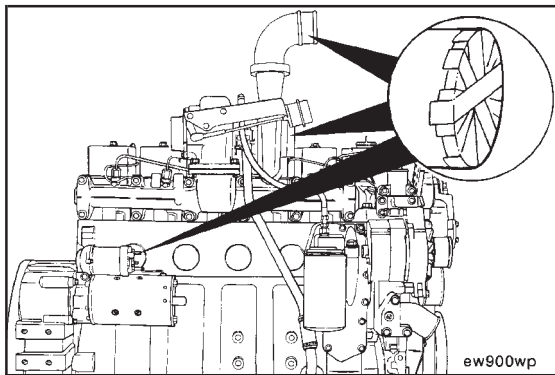

**Engine - Painting (14-08)**



Remove all belts from the engine.

Cover the following parts of the engine:

- Exhaust and intake openings
- Electrical components
- Fuel inlet and drain connections
- Any exposed fittings, threads, and electrical wire terminals

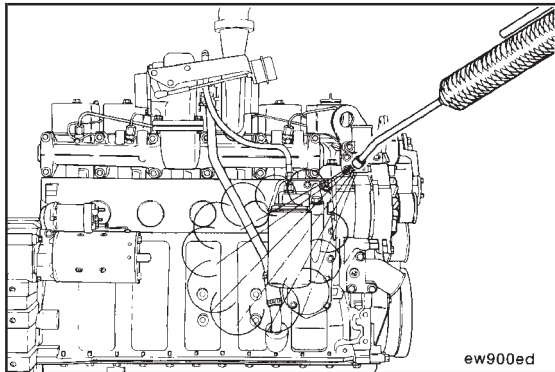

**Warning:** When using a steam cleaner, wear protective clothing and safety glasses or a face shield. Hot steam can cause serious personal injury.



Use steam to clean the engine, and dry with compressed air.

**NOTE:** Make sure all engine surfaces are clean and dry before painting the engine.

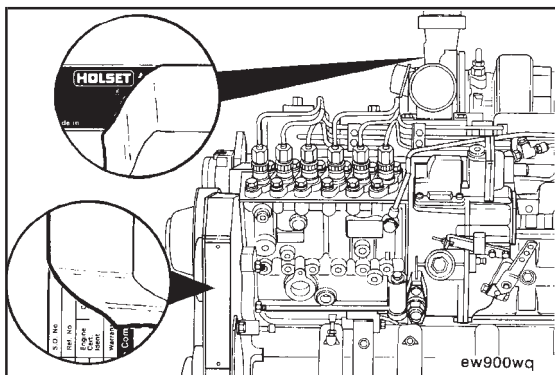

Protect the following components from the paint:

- All dataplates
- Valve and injector set marks.
- Exhaust manifold
- Turbocharger turbine housing
- Flywheel
- Flywheel housing transmission mounting surface

Paint the engine.

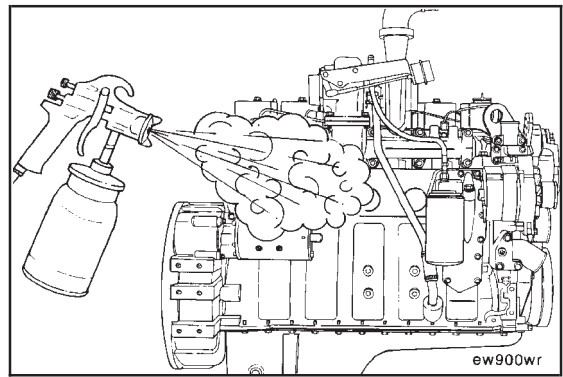

### Engine Storage - Short Term (14-09)

**NOTE:** This procedure describes the correct method of preparing an engine for short-term (1 to 6 months) storage.

Operate the engine at high idle until the coolant temperature reaches 70°C [160°F].

Shut off the engine.

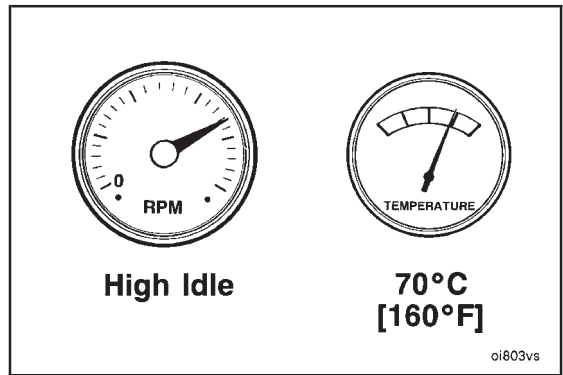

Remove the fuel tube to the engine fuel filter and the injector return tube.

**NOTE:** Fuel system preservative oil **must** meet Federal Specification VV-L-800C. (Example: Daubert Chemical NoxRust No. 518.)

Fill two containers, one with diesel fuel and the other with the preservative oil. Put both fuel tubes into the container of diesel fuel.

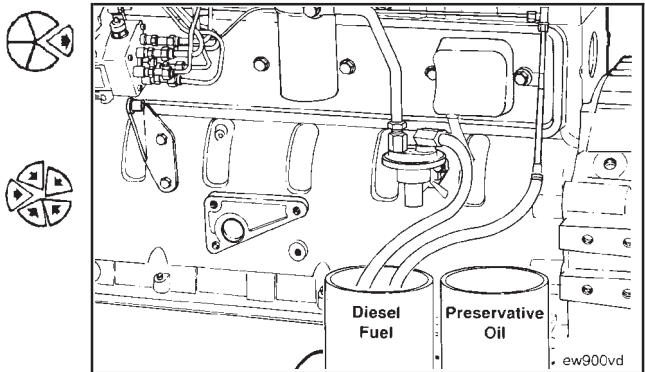

Start the engine. When it is operating smoothly, put the fuel supply tube into the container of preservative oil.

Remove the injector return tube from the diesel fuel container. When preservative oil flows from the tube, shut off the engine.

Install the fuel supply tube to the fuel filter, and put a cap on all other fuel tubes.

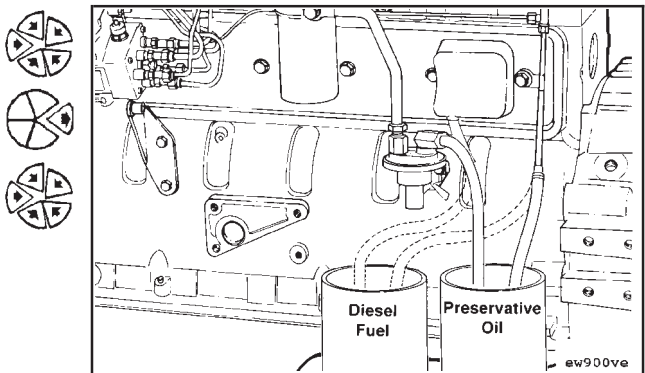

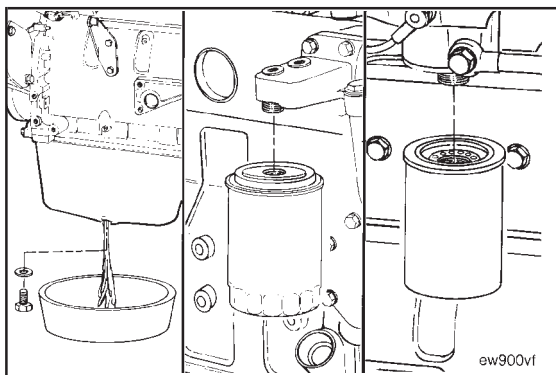

Drain the lubricating oil pan, the oil filters, and the fuel filter.



Install the drain plug into the oil pan, and install the filter cans. Tighten according to specifications.

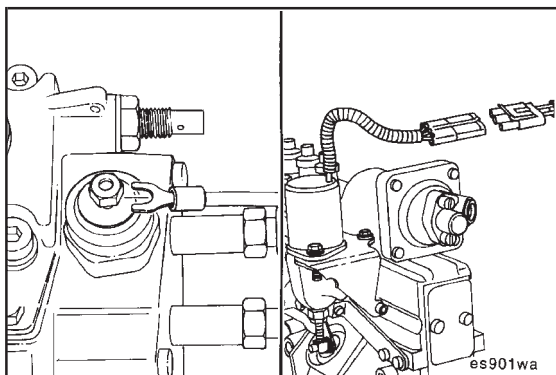

Disconnect the electrical wires from the fuel pump solenoid.

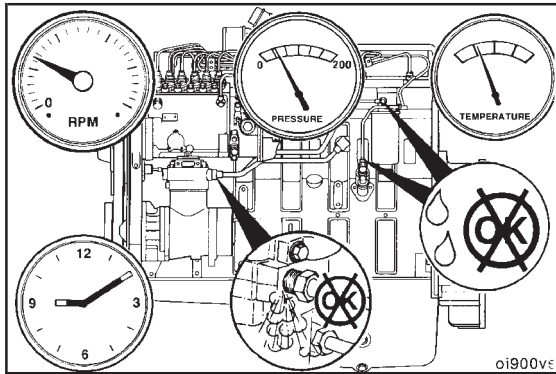

Drain the coolant passages and jackets.

**NOTE:** It is **not** necessary to drain the coolant if it is a permanent-type antifreeze with a rust inhibitor. Do **not** drain the coolant if the engine is installed in a vehicle.

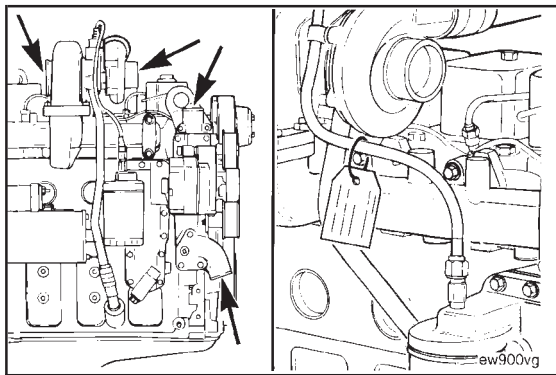

Look the engine over closely, and cover all openings with tape to prevent dirt and moisture from entering.



Install a warning tag which alerts others of no oil in the engine and that it **must not** be started.

Store the engine in a dry area of even temperature.

Rotate the crankshaft two to three revolutions every 3 to 4 weeks use the barring gear, Part No. 3904682 to rotate the crankshaft.

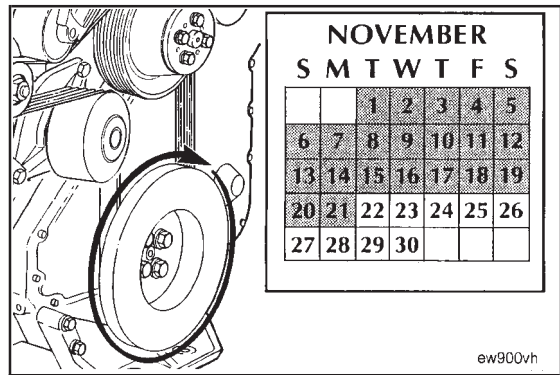

### Removing the Engine from Short-Term Storage

Remove the tape from all openings, and remove the warning tag.

Refill the oil filters with clean 15W-40 oil, and prime the lubrication system. Refer to Engine Dynamometer Test - Engine Run-in.

Use clean diesel fuel to flush the preservative oil from the fuel system, and fill the fuel filter again.

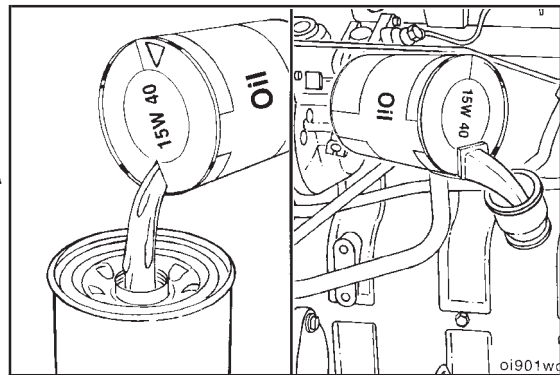

Connect the electrical wiring to the fuel pump solenoid. Prime and vent the fuel system.

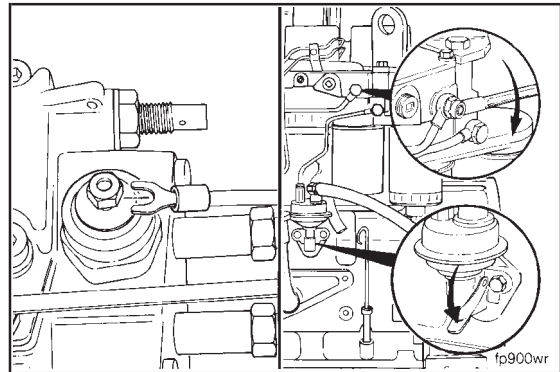

### Engine Storage - Long Term (14-10)

This procedure describes the correct method of preparing an engine for long-term (6 to 24 months) storage.

**NOTE:** If the engine has been stored for 24 months, the cooling system **must** be flushed with a solvent. Repeat the flushing procedure a second time.

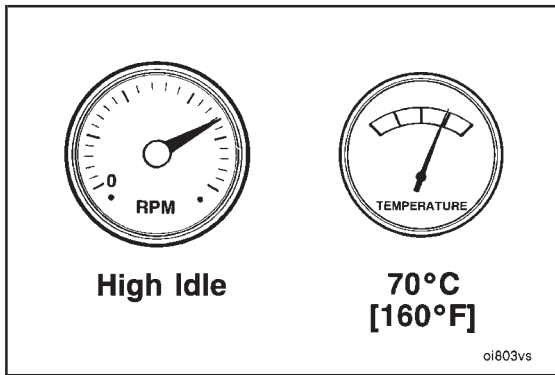

Operate the engine at the high idle throttle position until the coolant temperature is 70°C [160°F].

Shut off the engine.

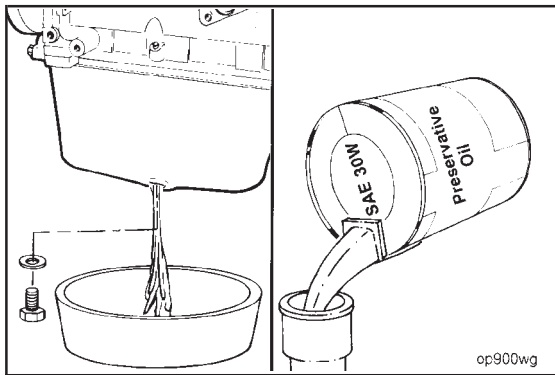

Drain the lubricating oil pan. Install the drain plug, and fill the oil pan to the high level mark on the dipstick with preservative oil.

**NOTE:** Lubricating system preservative oil **must** meet Military Specification MIL-L-21260 Type PE30-1 SAE 30. (Example: Shell 66202.)

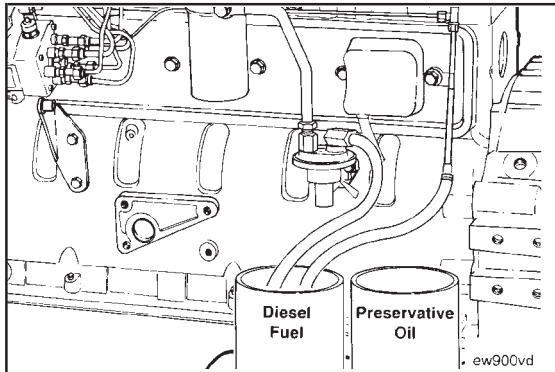

Disconnect the fuel supply tube at the fuel filter and the injector return tube at a convenient place.

**NOTE:** Fuel system preservative oil **must** meet Federal Specification VV-L-800C. (Example: Daubert Chemical NoxRust No. 518.)



Fill two containers, one with diesel fuel and the other with preservative oil. Put both fuel tubes into the container of diesel fuel.

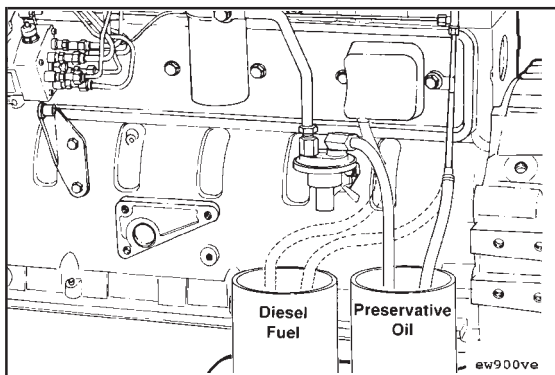

Start the engine and, when operating smoothly, put the fuel supply tube into the container of preservative oil.



Remove the injector return tube from the diesel fuel container. When the preservative oil flows from the tube, shut off the engine.



Connect the fuel supply tube to the fuel filter, and put a cap on the ends of all the other fuel tubes.



Drain the preservative oil from the lubricating oil pan and the oil filters. Install the drain plug.

Drain and flush the cooling system, using a water-soluble rust inhibitor.

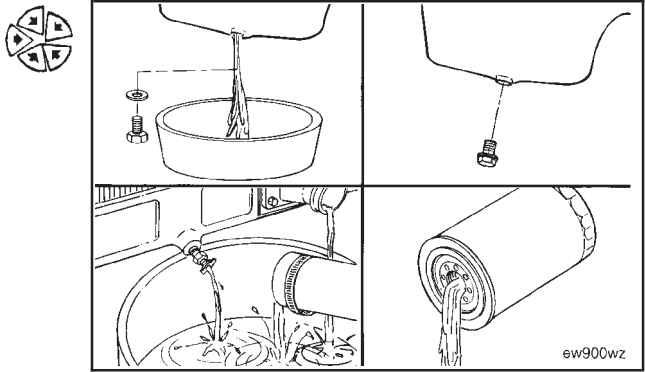

Remove the aftercooler assembly and the exhaust manifold. Refer to Engine Disassembly (00-01).

Spray preservative oil into the intake and the exhaust ports of the cylinder head and into the aftercooler housing and the exhaust manifold.

Install the aftercooler assembly and the exhaust manifold. Refer to Engine Assembly.

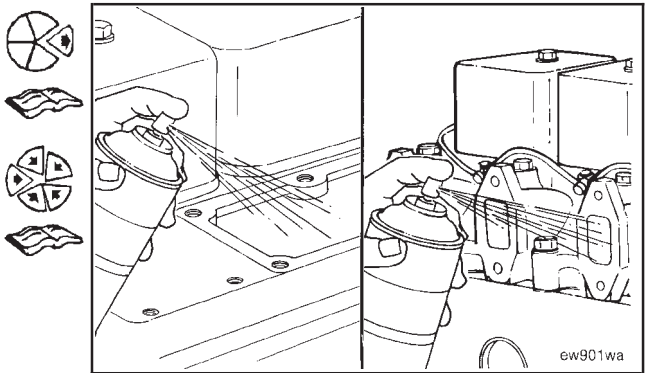

Remove the rocker housing covers, and spray the rocker levers, valve springs, valve stems, valve guides, and the push rods with preservative oil. Install the rocker housing cover.

Spray preservative oil into the intake port of the air compressor and on all exposed metal surfaces that are **not** painted.

**NOTE:** Use a preservative compound that meets Military Specification MIL-C-16137C Type P-2 Grade 1 or 2.

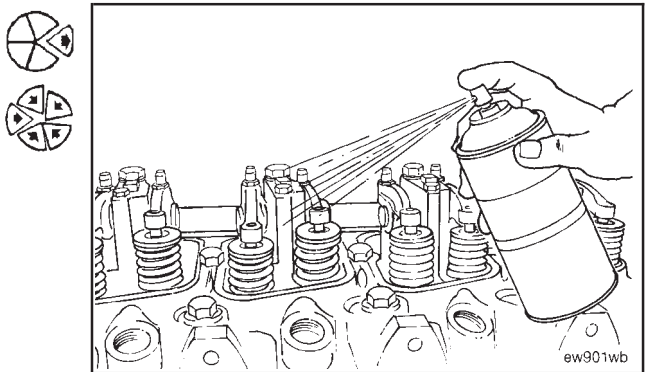

Cover all openings with heavy paper and tape to prevent entrance of dirt and moisture.

Put a warning tag on the engine which contains the following information:

- Date the engine was prepared for storage.
- Crankshaft **must not** be rotated.
- Coolant has been drained.
- Engine **must not** be operated.

Store the engine in a dry area of even temperature.

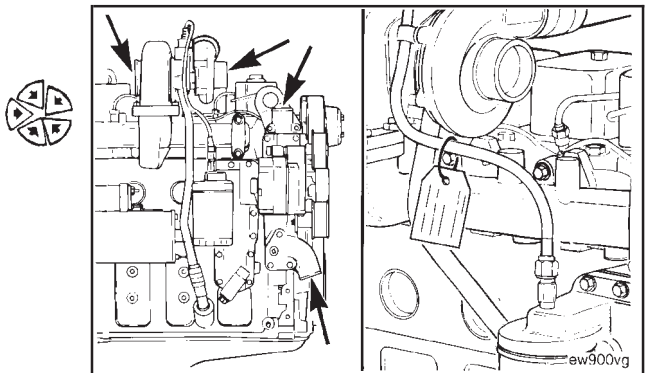

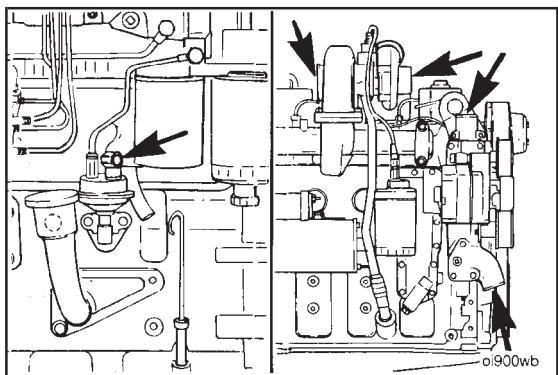

**Removing the Engine from Long-Term Storage**



Remove the paper and the tape from all openings.  
Remove the warning tag.

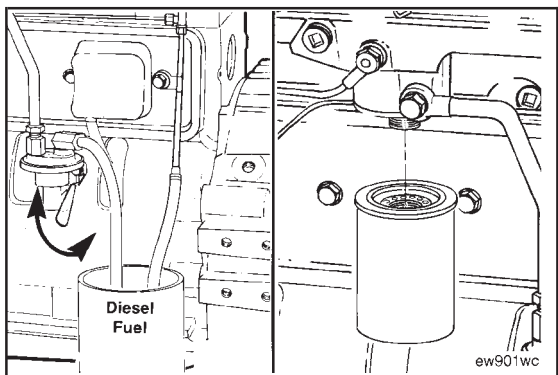

Flush the fuel system with clean diesel fuel to remove preservative oil.

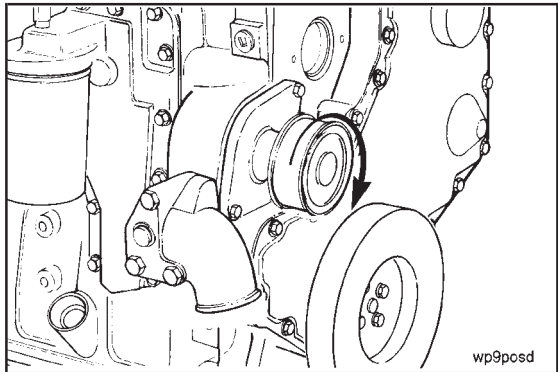

Rotate the water pump to make sure it hasn't rusted in place.

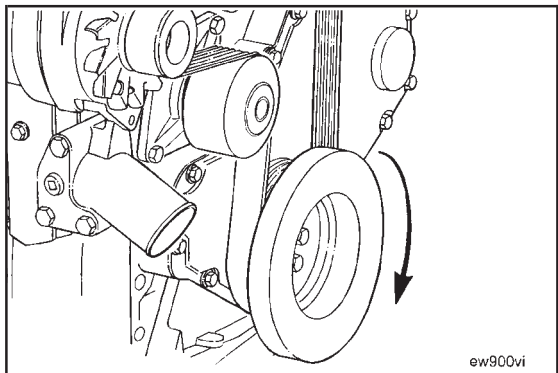

Rotate the crankshaft two complete revolutions to make sure the piston rings are free and no foreign objects are in the engine.

Remove the intake manifold cover or aftercooler and visually inspect the lower valve stem area for presence of rust. An accumulation of rust requires disassembly and rebuild of the cylinder head.

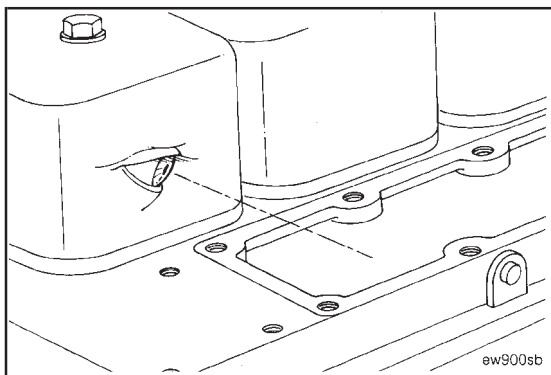

Install the drive belt or belts.

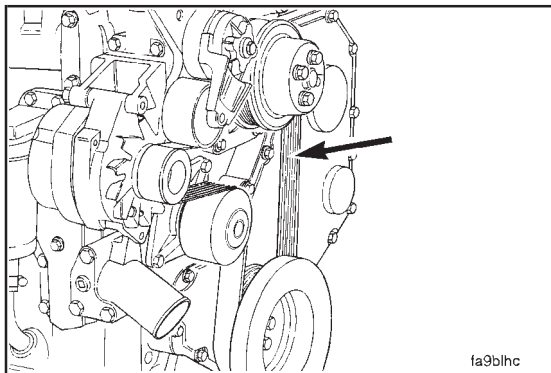

Remove a plug from the main oil rifle drilling and flush the preservative oil from the engine by pumping 4 liters of light mineral oil into the oil rifle. Rotate the crankshaft three or four revolutions as the engine is flushed. Install the plug.

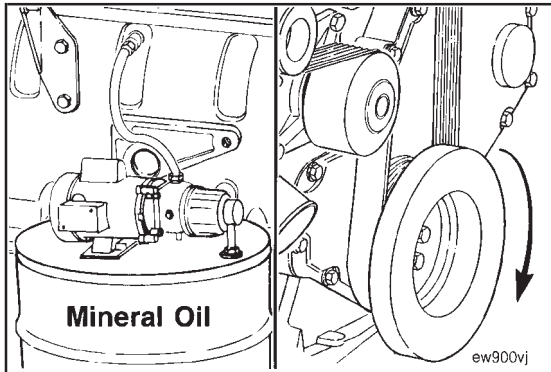

Remove the oil drain plug and allow the mineral oil to drain from the engine.

Install drain plug.

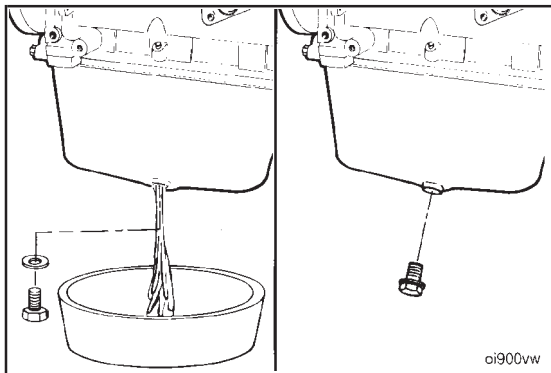

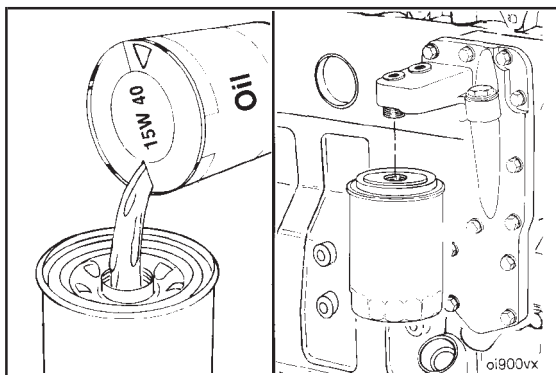

Remove the lubricating oil filter. Install a new filter according to the manufacturer's specifications.

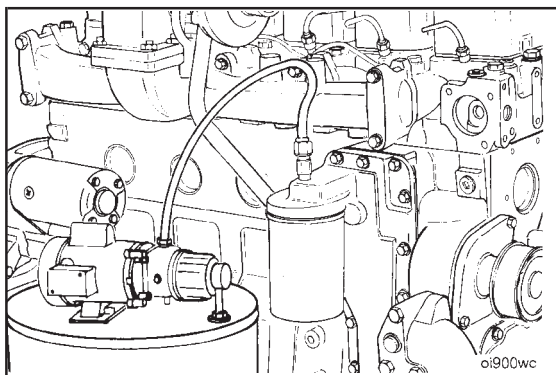

Pressure fill the engine with 15W40 lubricating oil through the 1.8 inch pipe tap on the side of the oil filter housing directly below the turbocharger oil supply connection. Use 207 kPa (30 psi) to pressure fill the system with a minimum of 3.6 L (1 U.S. gal).

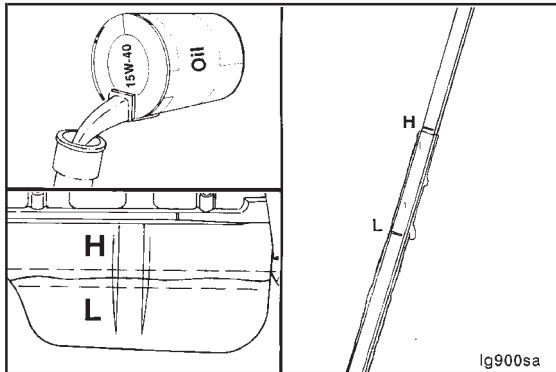

Reinstall the drain plug and fill the oil pan to the high mark on the dipstick.

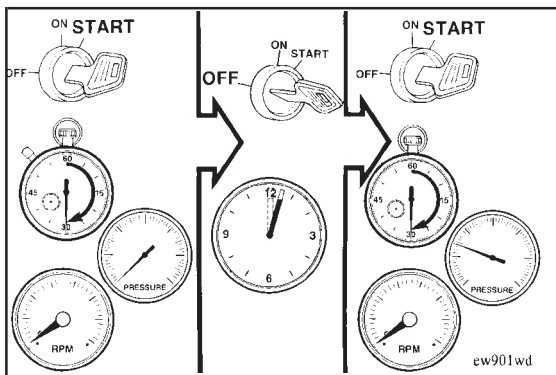

**Caution:** Make sure the engine does not start when you crank the engine by disconnecting the fuel solenoid or positioning the shut down lever in the stop position.



Use the starter to crank the engine for a maximum of 30 seconds, with two minute intervals, until oil pressure registers on the lubricating oil pressure gauge.



Install a new coolant filter if so equipped. Fill the cooling system with a mixture of 50% water and 50% ethylene-glycol type antifreeze.

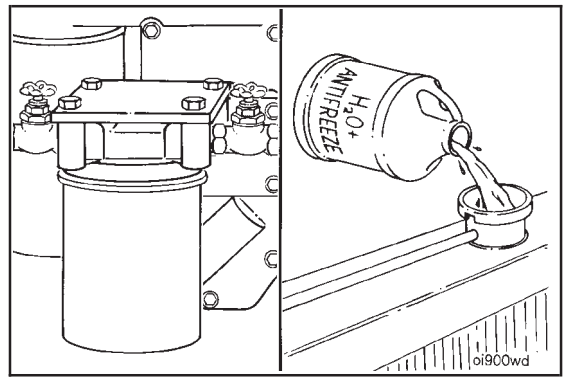

Adjust the valve clearance according to the procedure in the applicable service manual.

Tighten all capscrews, plugs and fittings as necessary.

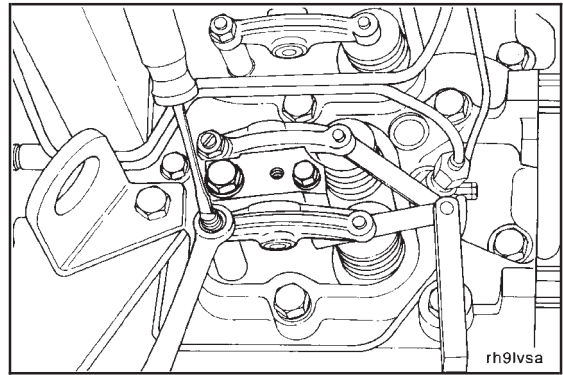



# Section 16 - Mounting Adaptations - Group 16

## Section Contents

	Page
<b>Flywheel and Ring Gear Inspection</b> .....	16-3
<b>Flywheel Housing Assembly</b> .....	16-4
Wet Clutch Application .....	16-5
<b>Flywheel Housing Inspection</b> .....	16-4
<b>Front Support - Cleaning and Inspection</b> .....	16-6
<b>General Information</b> .....	16-2
Flywheel and Ring Gear .....	16-2
Flywheel Housing .....	16-2
Front Support .....	16-2
<b>Ring Gear Replacement</b> .....	16-3

## General Information

### Flywheel Housing

The flywheel housings are available in different sizes and styles for the various applications. Ring dowels are used to locate the housing within 0.20 mm [0.008 in] total indicated runout. Service housings are drilled for the dowels and re-dowelling is not required. Check the appropriate parts book and the engine parts listing for the correct part number for the engine application being serviced.

### Flywheel and Ring Gear

The flywheel is available only as an assembly. The assembly includes the flywheel and the ring gear. The ring gear is available for service.

### Front Support

Several different types of front engine mounts are available, depending upon specific applications.



### Flywheel and Ring Gear Inspection (16-01)

Check the ring gear teeth for wear or damage. Use the dye penetrant method to check the mounting holes for cracks. Check the clutch face surface for cracks or damage. If equipped with a flexplate, check the flexplate for cracks or damage.

**NOTE:** If the ring gear teeth are worn or damaged, the ring gear must be replaced.

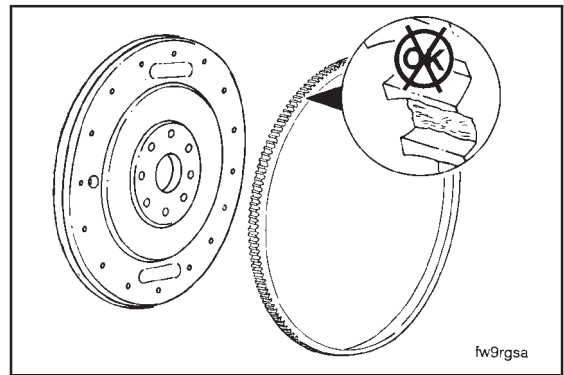

fw9rgsa

### Ring Gear Replacement (16-02)

#### Brass Drift Pin

**Warning:** Wear eye protection when you drive the gear from the flywheel. Do not use a steel drift pin.

Use the drift pin to drive the ring gear from the flywheel.

**NOTE:** The ring gear on flexplate applications cannot be replaced as a separate unit. The entire flexplate assembly must be replaced.

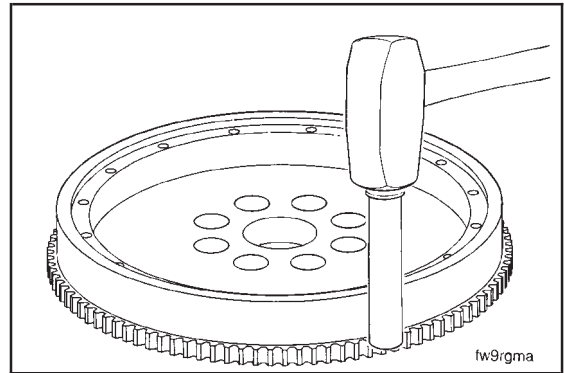

fw9rgma

Heat the new ring gear for 20 minutes in an oven preheated to 127°C [260°F].

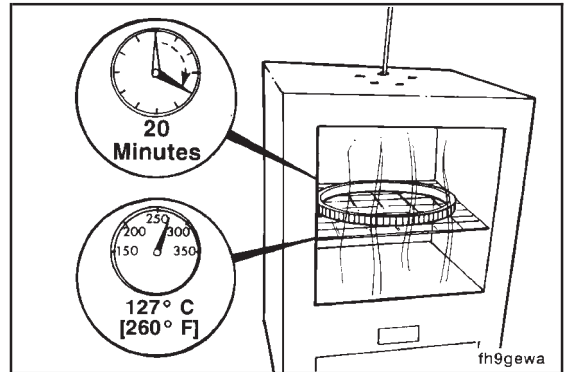

fh9gewa

**Warning:** Wear protective gloves when you install the heated gear.

Install the gear. The gear must be installed so the bevel on the teeth is toward the crankshaft side of the flywheel.

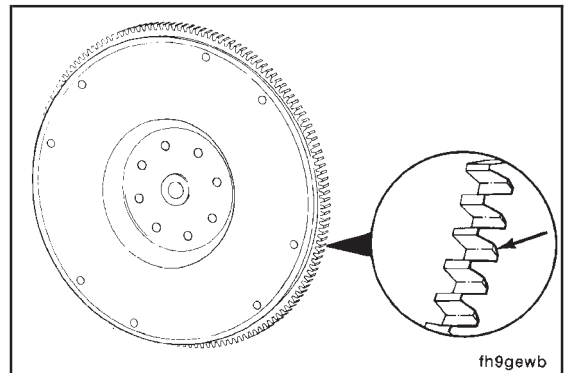

fh9gewb

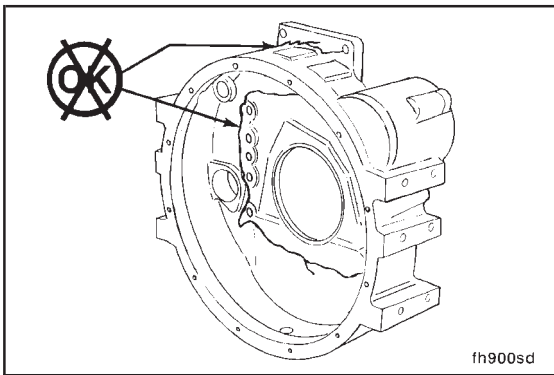

### Flywheel Housing Inspection (16-03)

Inspect the flywheel housing for cracks, especially in the bolt pattern area.

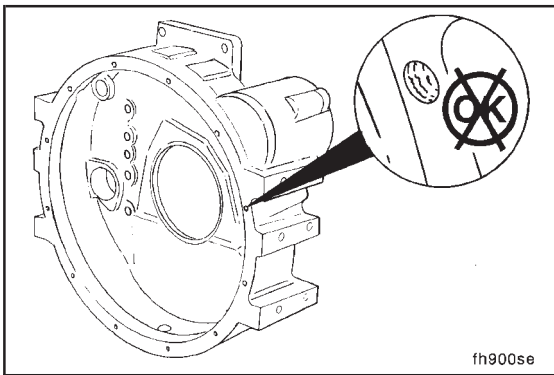

Inspect for damaged threads commonly caused by cross threaded capscrews or installing an incorrect capscrew. Heli-coils are available to repair damaged threads.

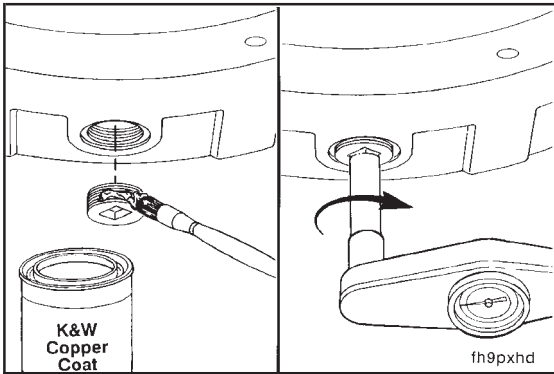

### Flywheel Housing Assembly (16-04)

#### 3/8 Inch Square Drive

Coat the drain plug with KW Copper Coat™ and install.



#### Torque Value

Cast Iron	55 N•m	[42 ft-lb]
Aluminum	35 N•m	[26 ft-lb]

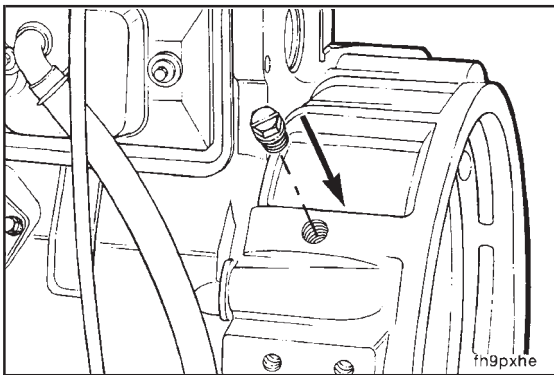

#### Screwdriver

Install the plastic plug in the tach probe hole.



Install the expanding plug in the barring tool hole.

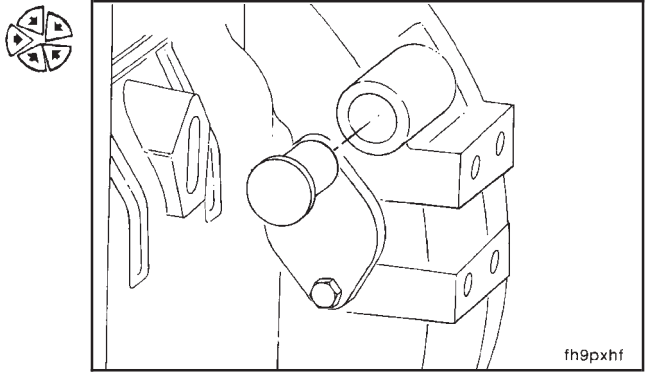

Coat both sides of the inspection plate gasket with KW Copper Coat<sup>™</sup>.

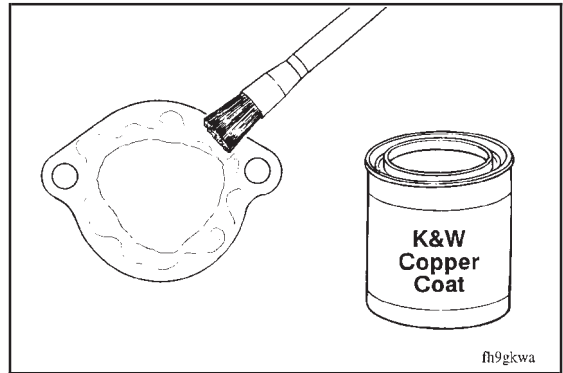

**13 mm**

Install the inspection plate.  
Tighten to 24 N•m [18 ft-lbs].

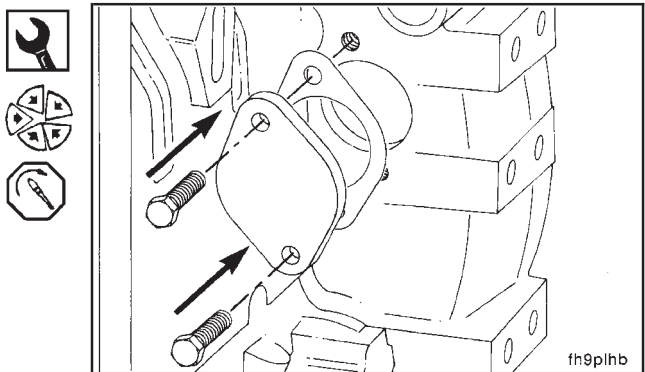

**Wet Clutch Application**

Perform all the steps in the procedure for dry clutch installation in addition to the following:

Coat the flywheel housing drain plug with pipe sealant and install in the hole in the bottom of the flywheel housing.

Tighten the plug.

Refer to the pipe plug torque values in Section 10 for different plug sizes.

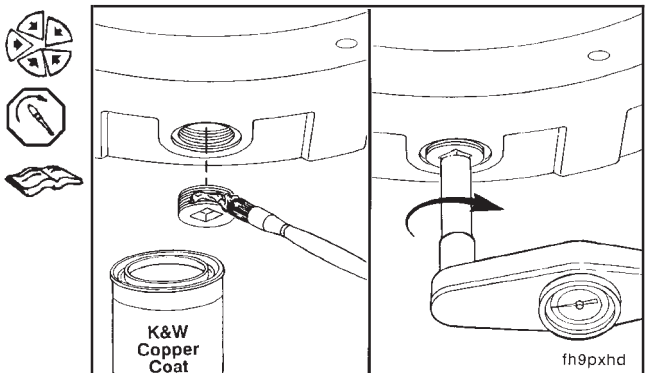

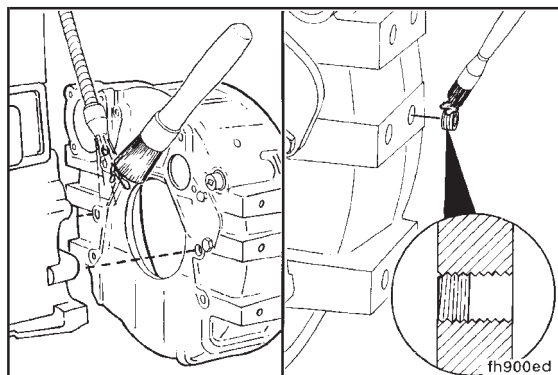

The capscrew holes on the mounting pads are drilled through. Coat set screws with Loctite™ 277 and install into holes.

Set Screw Installation Depth		
mm		in
0.00	MIN	0.000
3.00	MAX	0.118

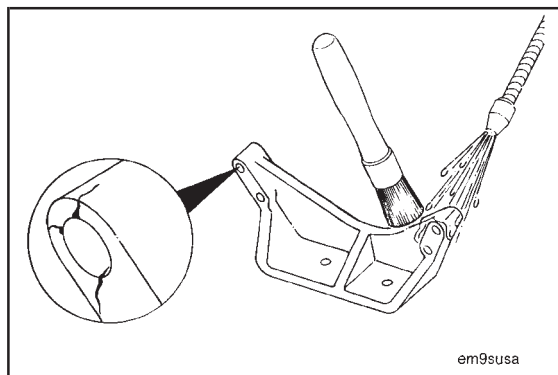

### Front Support - Cleaning and Inspection (16-05)



Use solvent. Clean the part.



Check the part for cracks or damage.

# Section V - Engine Component Specifications - Group 18

## Section Contents

	Page
<b>Capscrew Markings and Torque Values</b> .....	V-41
<b>Component Specifications and Torque Values</b> .....	V-6
Air Intake System.....	V-32
Combustion Air System.....	V-31
Compressed Air System Torque Values.....	V-33
Cylinder Block - Rebuild Specifications.....	V-16
Cylinder Block - Torque Values.....	V-22
Cylinder Head - Rebuild Specifications.....	V-23
Cylinder Head - Torque Values.....	V-25
Electrical System.....	V-34
Engine Assembly - Capscrew Torque Values.....	V-10
Engine Assembly - Specifications.....	V-6
Engine Testing - Test Specifications.....	V-35
Fan Hub - Specifications.....	V-31
Fuel System.....	V-26
Lubricating Oil System - Specifications.....	V-29
Rocker Levers and Pedestals.....	V-25
Tappet and Push Rods.....	V-26
Thermostat, Coolant Operating Temperature.....	V-31
<b>Drive Belt Tension</b> .....	V-36
<b>Engine Component Torque Values</b> .....	V-3, V-4, V-5
<b>Newton-Meter to Foot-Pound Conversion Chart</b> .....	V-39
Capscrew Markings and Torque Values - U.S. Customary.....	V-40
<b>Pipe Plug Torque Values</b> .....	V-42
<b>Specifications - General Information</b> .....	V-2
<b>Tap-Drill Chart - U.S. Customary &amp; Metric</b> .....	V-43
<b>Weight and Measures - Conversion Factors</b> .....	V-38

### Specifications - General Information

This specification section contains the engine specifications for the B series engines. A detailed Engine Component Torque Value sheet is provided in addition to a summary listing with reduced line art of the key specifications from each section is included.

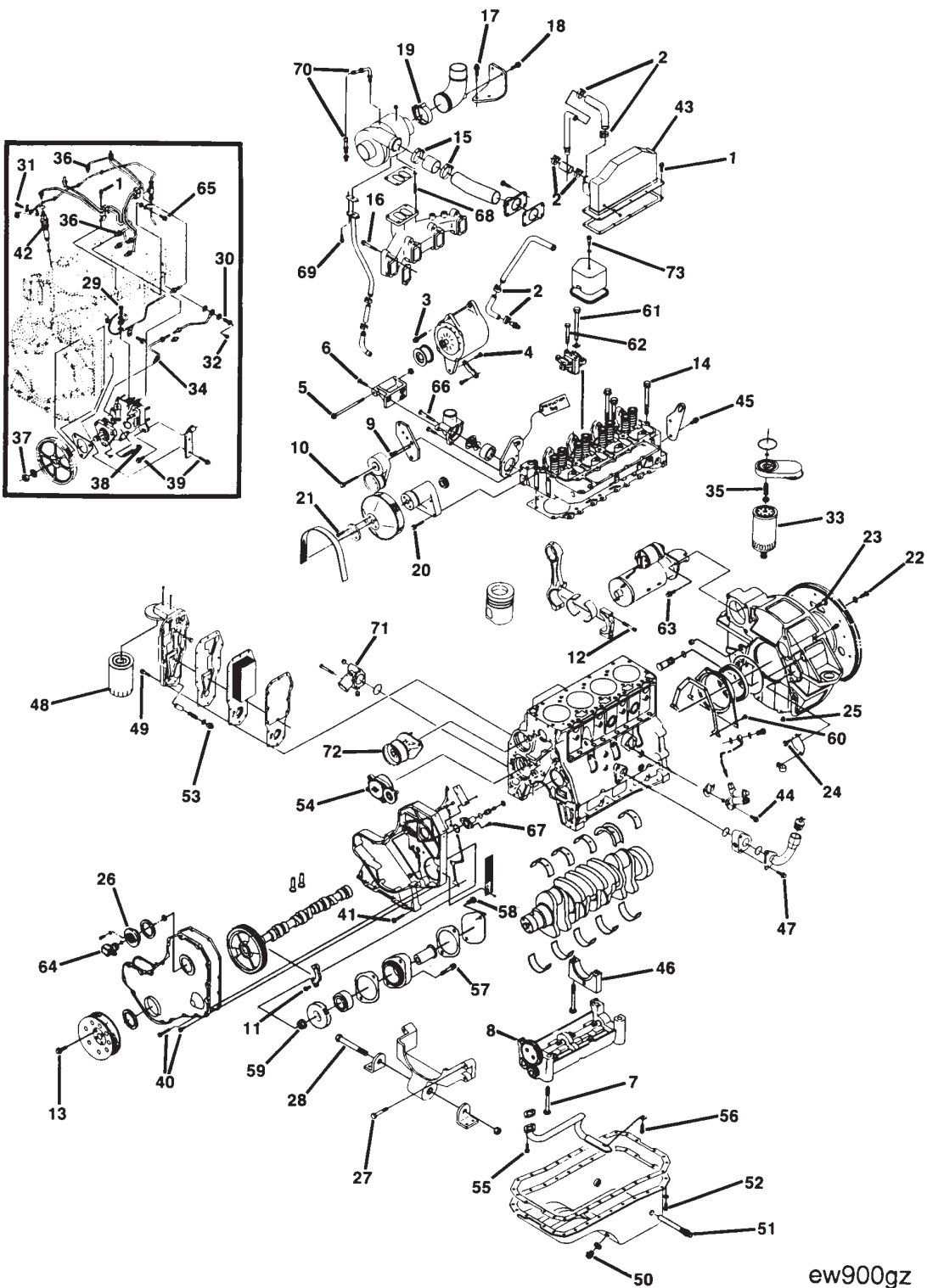

### Engine Component Torque Values

Ref. No.	Socket or Wrench Size MM[Inch]		Torque N•m	[Ft-lb]
1	10	Aftercooler Mounting.....	24	[ 18]
2	[5/16]	Aftercooler Water Hose Clamp.....	5	[ 4]
3	[15/16]	Alternator Pulley.....	80	[ 59]
4	13 or [3/4]	Alternator Link (Delco 15-20-27 SI).....	43	[ 32]
5	16	Alternator Mounting Bolt 15 SI.....	43	[ 32]
5	18	Alternator Mounting Bolt and Nut 20-27 SI.....	77	[ 57]
6	13	Alternator Support (Upper).....	24	[ 18]
7	23	Balancer Mounting.....Step 1	50	[ 36]
		(Alternately Tighten.....Step 2	80	[ 58]
		in Three Steps).....Step 3	175	[129]
8	Allen 8mm	Balancer Idler Gear.....	43	[ 32]
9	Allen 5mm	Belt Tensioner Flat Bracket.....	24	[ 18]
10	15	Belt Tensioner Mounting.....	43	[ 32]
		Camshaft Bolt.....Step 1	27	[ 20]
		.....Step 2	Rotate 180 Degrees	
11	13	Cam Thrust Plate.....	24	[ 18]
	[3/8]	Coolant Heater.....	12	[ 9]
12	12	Connecting Rod Bolt.....Step 1	35	[ 26]
		(Alternately Tighten.....Step 2	70	[ 51]
		in Three Steps).....Step 3	100	[ 73]
13	15	Crankshaft Damper & Pulley.....	125	[ 92]
14	18	Cylinder Head Mounting.....Step 1 (All)	90	[ 66]
		.....Step 2 (All) Recheck to	90	[ 66]
		.....Step 3 (Long Capscrews)	120	[ 90]
		.....Step 4 Recheck (Long Capscrews Only)	120	[ 90]
		.....Step 5 (All) Rotate 90°		
15	[5/16]	Crossover Clamp.....	5	[ 4]
16	13	Exhaust Manifold.....	43	[ 32]
17	13	Exhaust Outlet Pipe Brkt. Mounting.....	43	[ 32]
18	13	Exhaust Outlet Pipe, Flanged.....	24	[ 18]
19	[7/16]	Exhaust Outlet Pipe, V Band Clamp.....	8	[ 6]
20	10	Fan Bracket Mounting.....	24	[ 18]
21	13	Fan Pulley.....	24	[ 18]
22	19	Flywheel.....	137	[101]
23	15	Flywheel Housing.....	77	[ 57]
24	13	Flywheel Housing Access Cover.....	24	[ 18]
15	[1/2]	Flywheel Housing Plug.....	36	[ 25]
26	--	Front Cover Cap.....	---Hand Tighten---	
27	18	Front Engine Support Mounting.....	77	[ 57]
28	[1 1/8]	Front Engine Support (Barrel).....	350	[257]
29	17	Fuel Banjo Screw (In Fuel Pump).....	32	[ 24]
30	17	Fuel Banjo Screw (In Head).....	24	[ 18]
31	10	Fuel Banjo Screw (In Injector).....	9	[ 7]
32	10	Fuel Vent Screw (In Banjo).....	9	[ 7]
33	80-95	Fuel Filter.....	3/4 Turn After Contact	
34	14	Fuel Low Pressure Supply (Lift Pump Outlet).....	24	[ 18]
35	24	Fuel Filter Adapter Nut.....	32	[ 24]
36	17	Fuel Line Fitting (High Press).....	24	[ 18]

### Engine Component Torque Values

Ref. No.	Socket or Wrench Size MM[Inch]		Torque N•m	[Ft-lb]
37	22	Fuel Pump Drive Gear (With Pump Unlocked)		
		Bosch (Rotary), Lucas CAV, Stanadyne DB4.....	65	[ 48]
		Nippondenso.....	123	[ 92]
		Bosch (P3000, P7100).....	165	[122]
	10	Fuel Pump Lock (Bosch).....	30	[ 22]
		Fuel Pump Unlock (Bosch.....	13	[ 10]
	[9/16]	Fuel Pump Lock (CAV) (Stanadyne DB4).....	12	[ 9]
		Fuel Pump Unlock (CAV) (Stanadyne DB4).....	12	[ 9]
38	13	Fuel Pump Mounting Nut (Bosch Rotary) (Stanadyne DB4).....	24	[ 18]
		Fuel Pump Mtg. Nut (Nippondenso).....	43	[ 32]
		Fuel Pump Mtg. Nut (Lucas CAV).....	30	[ 22]
		Fuel Pump Mtg. Nut (Bosch In-Line).....	43	[ 32]
		Fuel Pump Solenoid		
	24	(Bosch VE).....	43	[ 32]
	22	(CAV).....	15	[ 11]
39	10	Fuel Pump Support Bracket.....	24	[ 18]
40	10	Gear Cover.....	24	[ 18]
41	10	Gear Housing-to-Block.....	24	[ 18]
42	24	Injector Retaining Nut.....	60	[ 44]
43	10	Intake Manifold Cover.....	24	[ 18]
	[5/8]	Intake Heater Plug.....	125	[ 90]
44	10	Lift Pump Mounting/Cover Plate.....	24	[ 18]
45	18	Lifting Bracket (Rear).....	77	[ 57]
46	23	Main Bearing Cap.....	60	[ 44]
		.....Step 1		
		.....Step 2	119	[ 88]
		.....Step 3	176	[129]
47	15	Oil Fill Tube Mounting.....	43	[ 32]
48	75-85	Oil Filter.....	3/4 Turn After Contact	
49	10	Oil Cooler Assembly.....	24	[ 18]
50	17	Oil Pan Drain Plug.....	80	[ 60]
51	17	Oil Pan Heater Plug.....	80	[ 60]
52	10	Oil Pan Mounting.....	24	[ 18]
53	19	Oil Pressure Regulator Plug.....	80	[ 60]
54	13	Oil Pump Mounting.....	24	[ 18]
55	13	Oil Suction Tube (Flange).....	24	[ 18]
56	10	Oil Suction Tube Brace.....	24	[ 18]
57	15	PTO Adapter.....	77	[ 57]
58	13	PTO Adapter Cover Plate (A Drive).....	43	[ 32]
	15	PTO Adapter Cover Plate (B Drive).....	77	[ 57]
59	[3/4]	PTO Gear Nut A Drive.....	100	[ 74]
	[15/16]	PTO Gear Nut B Drive.....	134	[100]
60	8	Rear Seal Mounting.....	9	[ 7]
61	13	Rocker Support.....	24	[ 18]
62	[14]	Rocker Lever Nut.....	34	[ 25]
63	10	Starter Mounting.....	43	[ 32]
64	10	Tach Drive Retainer.....	3	[ 2]
65	10	Tappet Cover/Fuel Drain Line Supports.....	24	[ 18]
66	10	Thermostat Housing.....	24	[ 18]
67	T-25 Torx	Timing Pin Flange Mounting.....	5	[ 4]
	10	Turbocharger Compressor Housing V-Band.....	8.5	[ 6]
68	15	Turbocharger Mounting Nut.....	43	[ 32]



### Engine Component Torque Values

Ref. No.	Socket or Wrench Size MM[Inch]		Torque	
			N•m	[Ft-lb]
69	13	Turbocharger Oil Drain Tube .....	24	[ 18]
70	[5/8]	Turbocharger Oil Supply (Both Ends) .....	35	[ 26]
	13	Turbocharger Turbine Housing .....	20	[ 15]
		Water Hose Clamps .....	4-5	[ 4]
71	13	Water Inlet Connection.....	43	[ 32]
	[3/8]	Water Inlet Plugs .....	24	[ 18]
72	13	Water Pump Mounting .....	24	[ 18]
73	15	Valve Cover.....	24	[ 18]
--	--	Valve Cover Oil Fill .....	Hand Tighten	

Component or Assembly (Procedure)	Ref.No./Steps	Metric	U.S.
-----------------------------------	---------------	--------	------

## Component Specifications and Torque Values

### Engine Assembly - Specifications

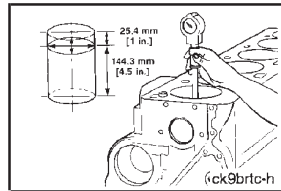

#### Cylinder Bores

Cylinder Bore I.D.		102.000 mm	MIN	4.0157 in
		102.116 mm	MAX	4.0203 in
Cylinder Bore Out of Round		0.035 mm	MAX	0.0014 in
Cylinder Bore Taper		0.076 mm	MAX	0.003 in

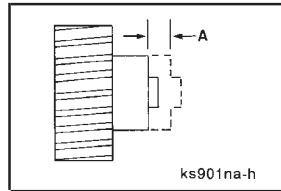

#### Crankshaft End Clearance

	A	0.102 mm	MIN	0.004 in
		0.432 mm	MAX	0.017 in

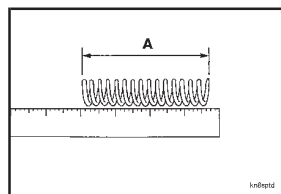

#### Oil Pressure Regulating Spring

• Spring Free Length				
1991 Engines				
1994 Engines				
	A	60.6 mm	MIN	2.385 in
		66.0 mm	MIN	2.598 in

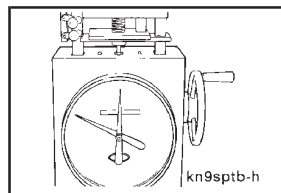

#### • Spring Tension at 38.50 mm [1.516 in] Height

(A) 1991 Engines	(A)	109.0 N	MIN	24.5 lb
(B) 1994 Engines	(B)	141.2 N	MIN	31.7 lb

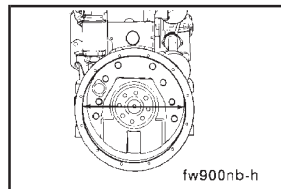

#### Flywheel Housing Bore I.D.

	SAE No.			
	2	447.8 mm	MAX	17.63 in
	3	409.7 mm	MAX	16.13 in

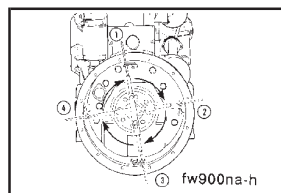

#### Flywheel Housing Bore Alignment TIR

		0.20 mm	MAX	0.008 in
--	--	---------	-----	----------

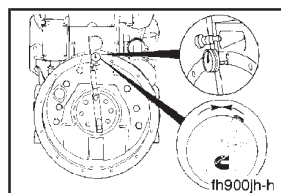

#### Flywheel Housing Face Alignment TIR

	SAE No.			
	2	0.20 mm	MAX	0.008 in
	3	0.20 mm	MAX	0.008 in

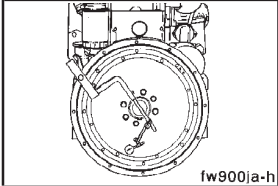
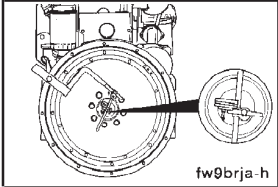
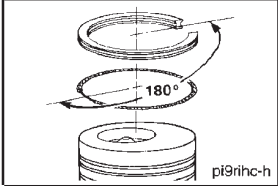
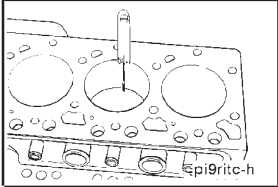
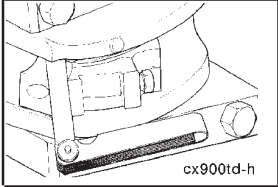
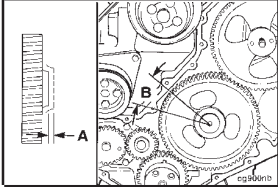
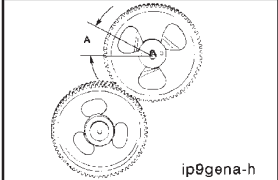
Component or Assembly (Procedure)	Ref.No./Steps	Metric		U.S.		
Flywheel Face Runout TIR	Radius				 <p>fw900ja-h</p>	
	mm	in				
	254	10	0.254	MAX		0.010
	205	8	0.203	MAX		0.008
	181	7	0.152	MAX		0.006
	157	6	0.152	MAX		0.006
133	5	0.152	MAX	0.006		
Flywheel Bore Runout TIR		0.127	MAX	0.0050	 <p>fw90brja-h</p>	
Oil Control Ring End Gap		The two-piece oil ring <b>must</b> be installed with the expander gap 180 degrees from the oil ring gap.			 <p>pi9rhc-h</p>	
Ring Gap (Feeler Gauge)					 <p>epi9ritc-h</p>	
• Top Ring Gap - Naturally Aspirated		0.25 mm	MIN	0.010 in		
		0.55 mm	MAX	0.022 in		
• Top Ring Gap - Turbocharged		0.40 mm	MIN	0.016 in		
		0.70 mm	MAX	0.028 in		
• Intermediate Ring Gap		0.25 mm	MIN	0.010 in		
		0.55 mm	MAX	0.022 in		
• Oil Control Ring Gap		0.25 mm	MIN	0.010 in		
		0.55 mm	MAX	0.022 in		
Connecting Rod Side Clearance		0.100 mm	MIN	0.004 in	 <p>cx900td-h</p>	
		0.330 mm	MAX	0.013 in		
		<b>Note:</b> The rod <b>must</b> move freely from side-to-side.				
Camshaft End Clearance		0.08 mm	MIN	0.003 in	 <p>cg900rb</p>	
		0.47 mm	MAX	0.0185 in		
Injection Pump Drive Gear Backlash	A	0.076 mm	MIN	0.003 in	 <p>ip9gena-h</p>	
		0.330 mm	MAX	0.013 in		

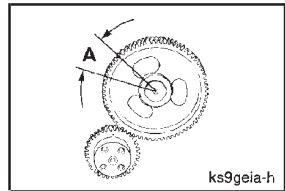
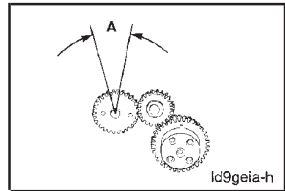
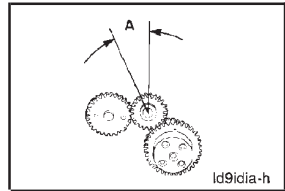
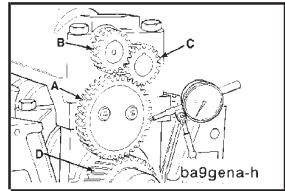
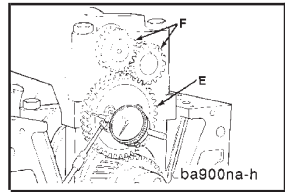
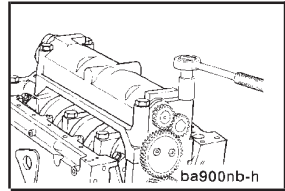
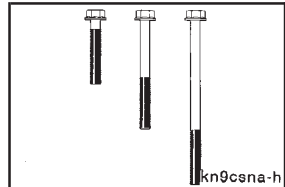
	Component or Assembly (Procedure)	Ref.No./Steps	Metric		U.S.
 <p>ks9geia-h</p>	<b>Camshaft Gear Backlash</b>	A	0.076 mm 0.330 mm	MIN MAX	0.003 in 0.013 in
 <p>ld9geia-h</p>	<b>Lubricating Oil Pump Gear Backlash</b>	A	0.076 mm 0.330 mm	MIN MAX	0.003 in 0.013 in
 <p>ld9idia-h</p>	<b>Lubricating Oil Pump Idler Gear Backlash</b>	A	0.076 mm 0.330 mm	MIN MAX	0.003 in 0.013 in
 <p>ba9gena-h</p>	<b>Balancer Gear Backlash</b>	A to D B to C A to C	0.088 mm 0.420 mm 0.153 mm 0.355 mm 0.088 mm 0.420 mm	MIN MAX MIN MAX MIN MAX	0.003 in 0.017 in 0.006 in 0.014 in 0.003 in 0.017 in
 <p>ba900na-h</p>	<b>Balancer End Clearance</b>	E F	0.13 mm 0.63 mm 0.075 mm 0.175 mm	MIN MAX MIN MAX	0.005 in 0.024 in 0.003 in 0.007 in
 <p>ba900nb-h</p>	<b>Balancer Torque Value and Sequence</b>	1 2 3	50 N•m 80 N•m 176 N•m		36 ft-lb 58 ft-lb 129 ft-lb
 <p>kn9csna-h</p>	<b>Cylinder Head Capscrew Free Length (Maximum)</b> Short Medium Long		71.5 mm 122.1 mm 182.9 mm	MAX MAX MAX	2.815 in 4.807 in 7.201 in

Component or Assembly (Procedure)	Ref.No./Steps	Metric		U.S.
-----------------------------------	---------------	--------	--	------

**Vibration Damper**

Index line out of alignment  
Missing rubber member chunks

A	1.588 mm	MAX	0.0625 in
B	3.175 mm	MAX	0.1250 in

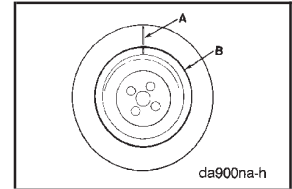

**Valve Stem to Rocker Lever Clearances**

Intake  
Exhaust

0.25 mm	0.010 in
0.51 mm	0.020 in

Locknut

34 N•m	25 ft-lb
--------	----------

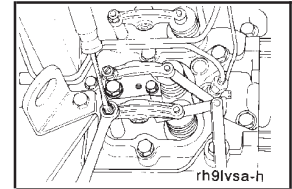

**Valve Adjustment Procedure**

Perform Step A of the valve set procedure with cylinder No. 1 at TDC compression stroke (timing pin will engage).

**Step A - Four Cylinder**

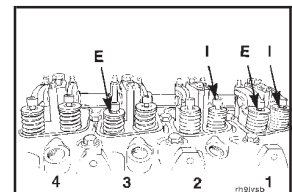

**Step A - Six Cylinder**

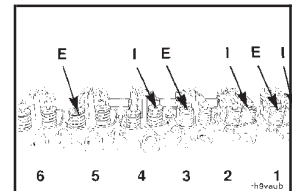

Perform Step B of the valve set procedure with cylinder No. 1 at TDC plus 360 degrees (timing pin will not engage).

Mark the crankshaft and gear cover. Rotate the crankshaft one full turn in the direction of engine rotation.

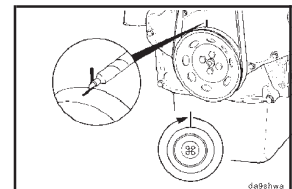

**Step B - Four Cylinder**

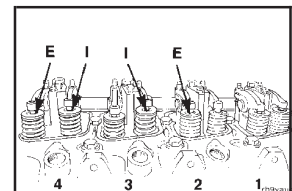

**Step B - Six Cylinder**

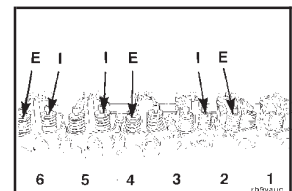

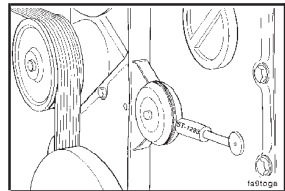
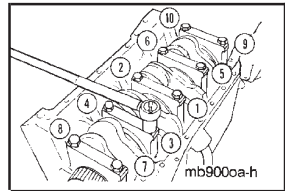
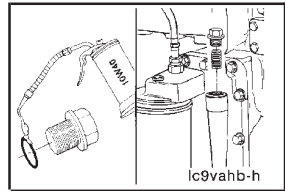
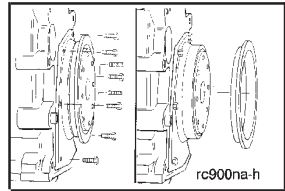
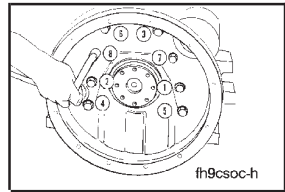
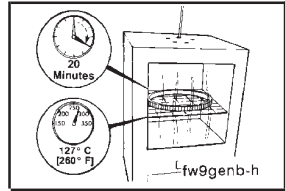
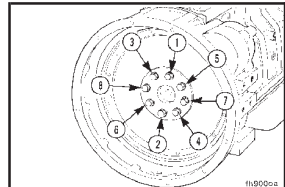
	Component or Assembly (Procedure)	Ref.No./Steps	Metric	U.S.
	<p><b>Belt Tension - Fan Drive</b></p> <p>Belt Tension</p>		<p>267 N 578 N</p>	<p>MIN MAX 60 lbf 130 lbf</p>
	<p><b>Engine Assembly - Capscrew Torque Values</b></p> <p>Main Bearing Capscrew Torque Value and Sequence</p>	<p>1 2 3</p>	<p>60 N•m 119 N•m 176 N•m</p>	<p>44 ft-lb 88 ft-lb 129 ft-lb</p>
	<p>Oil Pressure Regulator Retainer Plug</p>		<p>80 N•m</p>	<p>60 ft-lb</p>
	<p>Rear Seal Cover Mounting</p>		<p>9 N•m</p>	<p>84 in-lb</p>
	<p><b>Flywheel Housing Capscrews</b> <b>Note:</b> Tighten the capscrews in the sequence shown.</p>		<p>77 N•m</p>	<p>57 ft-lb</p>
	<p><b>Ring Gear Replacement</b> Heat the new ring gear for 20 minutes in an oven preheated to 127°C [260°F].</p>			
	<p><b>Flywheel Mounting Capscrews</b> Tighten in the sequence shown</p>		<p>137 N•m</p>	<p>101 ft-lb</p>

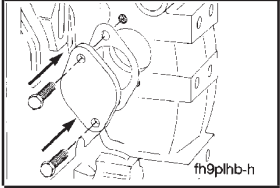
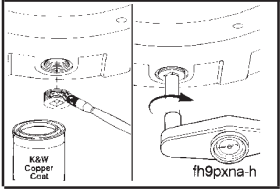
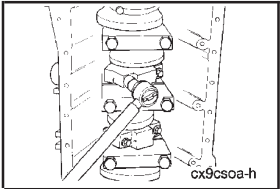
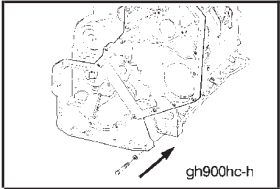
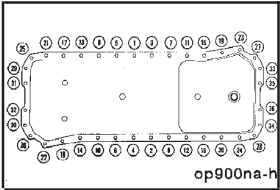
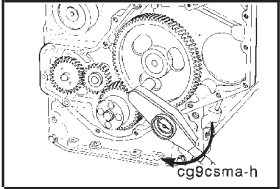
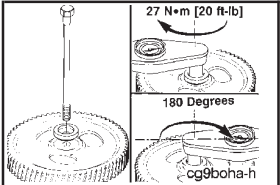
Component or Assembly (Procedure)	Ref.No./Steps	Metric	U.S.	
Flywheel Housing Access Cover		24 N•m	18 ft-lb	
Flywheel Housing Plug		36 N•m	27 ft-lb	
Connecting Rod Bolt	1 2 3	35 N•m 70 N•m 100 N•m	26 ft-lb 52 ft-lb 74 ft-lb	
Gear Housing Mounting Capscrews		24 N•m	18 ft-lb	
<b>Lubricating Oil Pan</b> <b>Note:</b> Tighten the capscrews in the sequence shown. Start at the center of the oil pan and alternate toward both ends.		24 N•m	18 ft-lb	
Camshaft Thrust Plate Capscrew		24 N•m	18 ft-lb	
<b>Camshaft Bolt</b> Step 1 Step 2		27 N•m Rotate 180 Degrees	20 ft-lb	

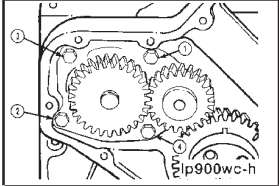
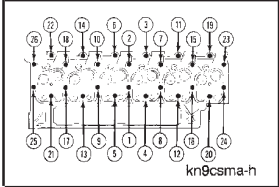
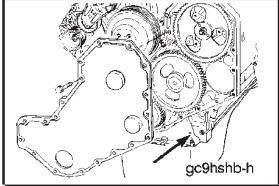
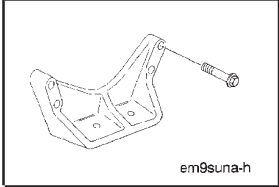
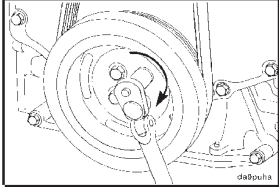
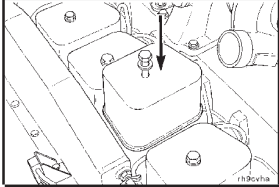
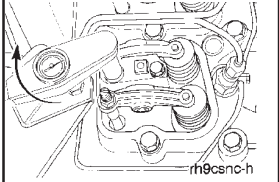
	Component or Assembly (Procedure)	Ref.No./Steps	Metric	U.S.
	<p><b>Oil Pump Mounting Capscrews</b> Tighten in the sequence shown</p>		24 N•m	18 ft-lb
	<p><b>Cylinder Head Mounting Capscrew</b> <b>(Tighten Capscrews in the Sequence Shown)</b> Step 1 Step 2 - Recheck to Step 3 - (Long capscrews only) Step 4 - (Long capscrews only) - Recheck to Step 5 - Rotate 90 degrees</p>		<p>90 N•m 90 N•m 120 N•m 120 N•m</p>	<p>66 ft-lb 66 ft-lb 90 ft-lb 90 ft-lb</p>
	<p><b>Gear Cover Capscrews</b></p>		24 N•m	18 ft-lb
	<p><b>Front Engine Support Mounting</b></p>		77 N•m	57 ft-lb
	<p><b>Crankshaft Pulley Capscrew</b></p>		125 N•m	92 ft-lb
	<p><b>Rocker Cover Capscrews</b></p>		24 N•m	18 ft-lb
	<p><b>Rocker Pedestal Cap screws (8 mm)</b></p>		24 N•m	18 ft-lb

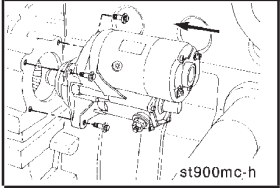
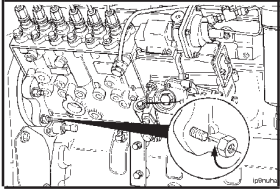
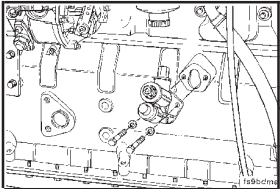
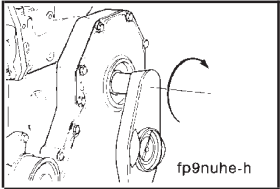
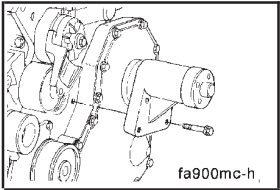
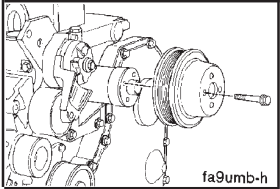
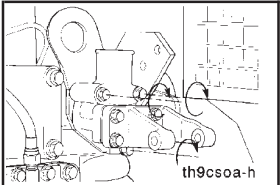

Component or Assembly (Procedure)	Ref.No./Steps	Metric	U.S.	
<b>Starting Motor Mounting Capscrews</b>		43 N•m	32 ft-lb	
<b>Injection Pump Mounting Nuts</b>				
Nippondenso		43 N•m	32 ft-lb	
Lucas CAV, Bosch (Rotary), Stanadyne DB4		30 N•m	22 ft-lb	
Bosch (In-Line)		43 N•m	32 ft-lb	
<b>Fuel Transfer Pump Mounting Capscrews</b>		24 N•m	18 ft-lb	
<b>Injection Pump Drive Gear Nut</b>				
Bosch (Rotary), Lucas CAV, Stanadyne DB4		65 N•m	48 ft-lb	
Nippondenso		123 N•m	92 ft-lb	
Bosch (P3000, P7100)		165 N•m	122 ft-lb	
<b>Fan Hub Mounting Capscrews</b>		24 N•m	18 ft-lb	
<b>Fan Hub Pulley Mounting Capscrews</b>	8 mm 10 mm	24 N•m 43 N•m	18 ft-lb 32 ft-lb	
<b>Thermostat Housing Mounting Capscrews</b>		24 N•m	18 ft-lb	

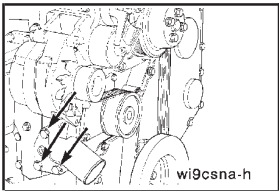
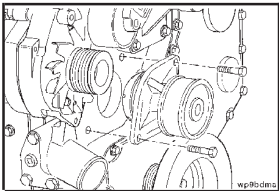
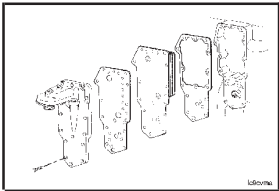
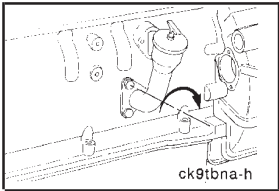
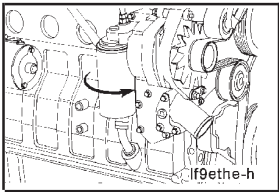
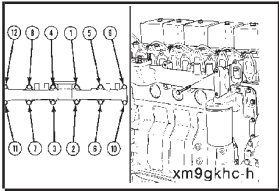
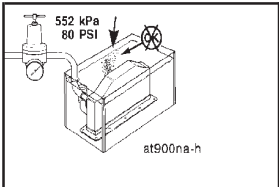
	Component or Assembly (Procedure)	Ref.No./Steps	Metric	U.S.
 <p>wi9csna-h</p>	<b>Coolant Inlet Connection</b>		43 N•m	32 ft-lb
 <p>wp9bdcna-h</p>	<b>Water Pump Mounting Capscrews</b>		24 N•m	18 ft-lb
 <p>lbc9na-h</p>	<b>Oil Cooler Mounting Capscrews</b>		24 N•m	18 ft-lb
 <p>ck9tbna-h</p>	<b>Oil Fill Tube Capscrews</b>		43 N•m	32 ft-lb
 <p>lf9ethe-h</p>	<b>Oil Filter</b>		3/4 Turn after contact	
 <p>xm9gkhc-h</p>	<b>Exhaust Manifold Capscrews</b>		43 N•m	32 ft-lb
 <p>at900na-h</p>	<b>Aftercooler - Inspection</b>	Inspect the housing and core for damage. Check the core for leaks: <ul style="list-style-type: none"> <li>• Plug the bottom inlet tube</li> <li>• Pressurize the core to 483 kPa [70 psi] and submerge in a container of water.</li> <li>• Water temperature at 60°C [140°F].</li> </ul>		

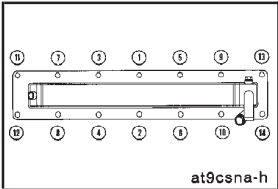
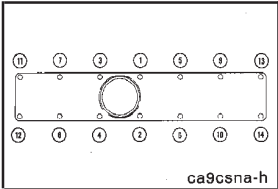
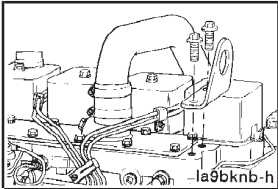
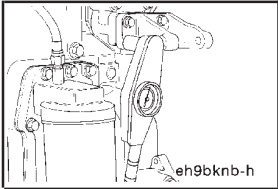
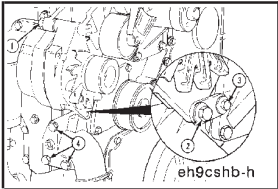
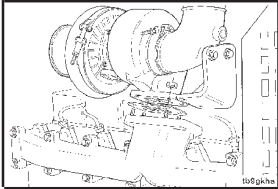
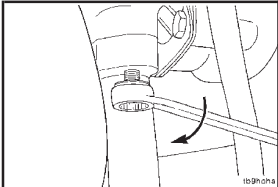
Component or Assembly (Procedure)	Ref.No./Steps	Metric	U.S.	
<b>Aftercooler Capscrews</b> <b>Note:</b> Tighten the capscrews in the sequence shown.		24 N•m	18 ft-lb	 <p style="text-align: right;">at9csna-h</p>
<b>Air Intake Manifold Capscrews</b> <b>Note:</b> Tighten the capscrews in the sequence shown.		24 N•m	18 ft-lb	 <p style="text-align: right;">ca9csna-h</p>
<b>Lifting Bracket (Rear)</b>		77 N•m	57 ft-lb	 <p style="text-align: right;">-la9bknb-h</p>
<b>Alternator Mounting Bracket Capscrews</b>		24 N•m	18 ft-lb	 <p style="text-align: right;">eh9bknb-h</p>
<b>Alternator Assembly Torque Sequence</b> <b>Note:</b> Tighten the capscrews in the sequence shown.				 <p style="text-align: right;">eh9cshb-h</p>
<b>Turbocharger Mounting Nuts</b>		43 N•m	32 ft-lb	 <p style="text-align: right;">ts9gk-h</p>
<b>Turbocharger Oil Drain Tube Mounting Capscrew</b>		24 N•m	18 ft-lb	 <p style="text-align: right;">ts9hch-h</p>

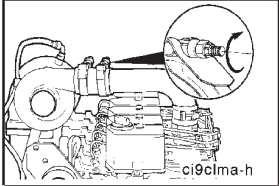
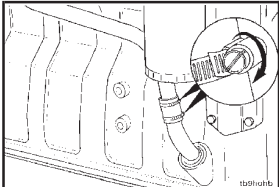
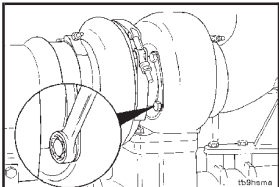
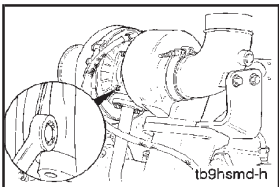
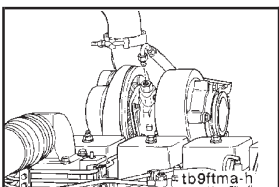
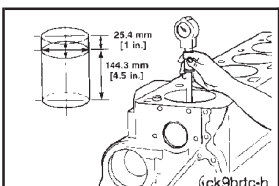
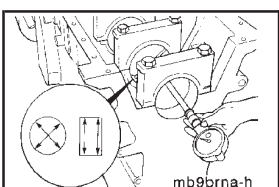
	Component or Assembly (Procedure)	Ref.No./Steps	Metric	U.S.	
 <p>ci9clma-h</p>	Turbocharger Air Crossover Hose Clamps		5 N•m	44 in-lb	
 <p>tb9hollb</p>	Turbocharger Oil Drain Line Hose Clamps		6 N•m	53 in-lb	
 <p>tb9hsmm</p>	Turbocharger Turbine Housing Capscrews		20 N•m	15 ft-lb	
 <p>tb9hsmcd-h</p>	<b>Turbocharger Compressor Housing</b> • Diffuser Plate Capscrews • V Band Clamp (Silver Plated Nut)		8.5 N•m	75 in-lb	
 <p>tb9ftma-h</p>	Turbocharger Oil Supply Line Connection		35 N•m	26 ft-lb	
 <p>6ck9brtc-h</p>	<b>Cylinder Block - Rebuild Specifications</b>				
	<b>Cylinder Bore Diameter</b>		102.000 mm	MIN	4.0157 in
			102.116 mm	MAX	4.0203 in
	Out-of-Roundness		0.035 mm	MAX	0.0014 in
	Taper		0.076 mm	MAX	0.003 in
 <p>mb9brna-h</p>	<b>Main Bearing Diameter</b> <b>(Bearings Installed) With Capscrews</b> <b>Tightened to 176 N•m [130 ft-lb]</b>		83.106 mm	MAX	3.27720 in

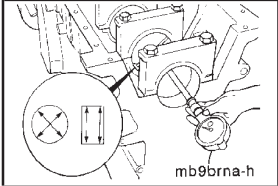
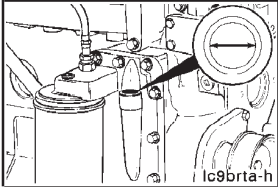
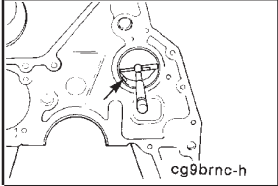
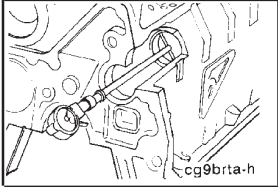
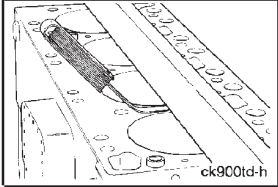
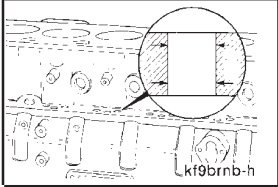
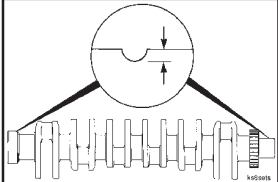
Component or Assembly (Procedure)	Ref.No./Steps	Metric		U.S.	
Main Bearing Bore I.D. (Without Bearings) With Capscrews Tightened to 176 N•m [130 ft-lb]		87.982 mm	MIN	3.4639 in	
		88.018 mm	MAX	3.4653 in	
Main Oil Pressure Regulator Valve Bore I.D.		18.30 mm	MIN	0.7205 in	
		18.35 mm	MAX	0.7224 in	
Camshaft Bore Diameter (Number 1 bore without bushing) (Number 1 bore with bushing installed)		57.222 mm	MIN	2.2528 in	
		57.258 mm	MAX	2.2543 in	
		54.107 mm	MIN	2.1302 in	
		54.146 mm	MAX	2.1317 in	
Camshaft Bore Diameter All Journals Except No. 1		54.089 mm	MIN	2.1295 in	
		54.164 mm	MAX	2.1324 in	
Cylinder Block Overall Flatness • End-to-end • Side-to-side		0.076 mm	MAX	0.003 in	
		0.051 mm	MAX	0.002 in	
Valve Tappet Bore Diameter		16.000 mm	MIN	0.630 in	
		16.055 mm	MAX	0.632 in	
Crankshaft Front and Rear Oil Seal Wear Groove		0.25 mm	MAX	0.010 in	

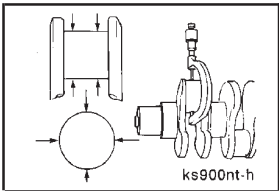
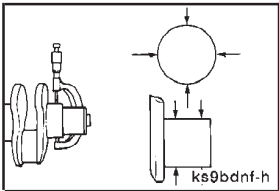
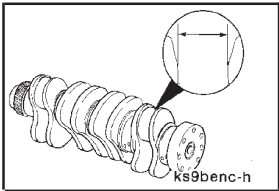
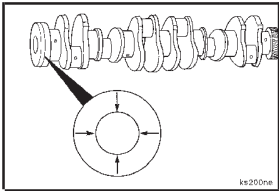
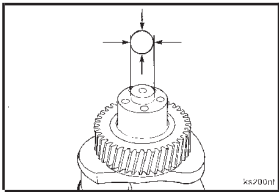
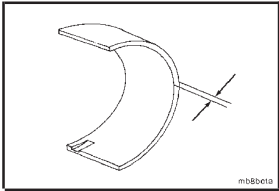
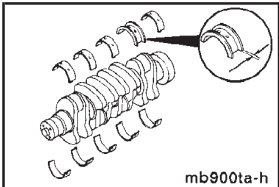
Component or Assembly (Procedure)	Ref.No./Steps	Metric	U.S.
 <p>ks900nt-h</p>	<p><b>Crankshaft Connecting Rod Journal O.D.</b></p> <p>Out of roundness</p> <p>Taper</p> <p>Bearing clearance</p>	<p>68.962 mm 69.013 mm 0.050 mm 0.013 mm 0.114 mm</p>	<p>MIN 2.7150 in MAX 2.7170 in MAX 0.002 in MAX 0.005 in MAX 0.0045 in</p>
 <p>ks9bdnf-h</p>	<p><b>Crankshaft Main Bearing Journal Diameter</b></p> <p>Out of roundness</p> <p>Taper</p> <p>Bearing clearance</p>	<p>82.962 mm 83.013 mm 0.050 mm 0.013 mm 0.119 mm</p>	<p>MIN 3.2662 in MAX 3.2682 in MAX 0.002 in MAX 0.005 in MAX 0.0047 in</p>
 <p>ks9benc-h</p>	<p><b>Crankshaft Thrust Face Width</b></p>	<p>37.475 mm 37.602 mm</p>	<p>MIN 1.4754 in MAX 1.4804 in</p>
 <p>ks200ne</p>	<p><b>Crankshaft Rear Oil Seal Flange O.D.</b></p>	<p>129.975 mm 130.025 mm</p>	<p>MIN 5.1171 in MAX 5.1191 in</p>
 <p>ks200nt</p>	<p><b>Crankshaft Damper Pilot O.D.</b></p>	<p>18.924 mm 19.000 mm</p>	<p>MIN 0.7450 in MAX 0.7480 in</p>
 <p>mb8bets</p>	<p><b>Main Bearing Shell Thickness (Standard)</b></p>	<p>2.438 mm 2.464 mm</p>	<p>MIN 0.0960 in MAX 0.0970 in</p>
 <p>mb900ta-h</p>	<p><b>Crankshaft Thrust Bearing Flange Thickness</b></p>	<p>2.45 mm 2.55 mm</p>	<p>MIN 0.096 in MAX 0.100 in</p>

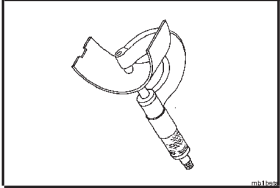
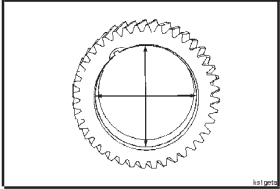
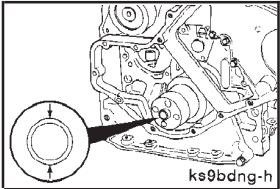
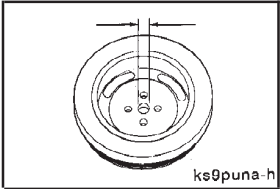
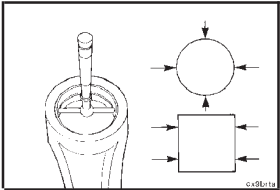
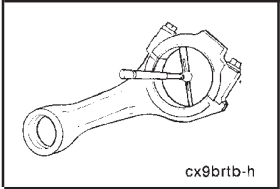
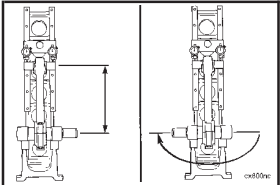
Component or Assembly (Procedure)	Ref.No./Steps	Metric		U.S.	
Connecting Rod Bearing Thickness (Standard)		1.955 mm 1.968 mm	MIN MAX	0.0769 in 0.0775 in	
Crankshaft Gear Bore I.D.		63.910 mm 63.934 mm	MIN MAX	2.5161 in 2.5171 in	
Crankshaft Gear Journal O.D.		63.987 mm 64.006 mm	MIN MAX	2.5192 in 2.5199 in	
Crankshaft Pulley Crankshaft Pilot Bore I.D.		19.05 mm 19.15 mm	MIN MAX	0.7500 in 0.7539 in	
Connecting Rod Piston Pin Bore I.D. Bushing Removed		42.987 mm 43.013 mm	MIN MAX	1.6924 in 1.6934 in	
Bushing Installed (1991 Engines)		40.053 mm 40.076 mm	MIN MAX	1.5769 in 1.5778 in	
Bushing Installed (1994 Engines)		40.019 mm 40.042 mm	MIN MAX	1.5756 in 1.5765 in	
Connecting Rod Crankshaft Bore I.D. (Bearings Installed)		69.051 mm 69.103 mm	MIN MAX	2.7185 in 2.7205 in	
(Bearings Removed)		72.987 mm 73.013 mm	MIN MAX	2.8735 in 2.8745 in	
Connecting Rod - Length		191.975 mm 192.025 mm	MIN MAX	7.5581 in 7.5600 in	
Connecting Rod - Alignment: • (With Bushing)		0.15 mm	MAX	0.006 in	

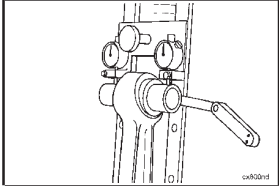
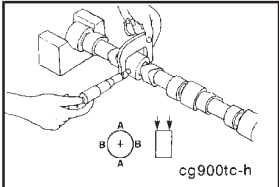
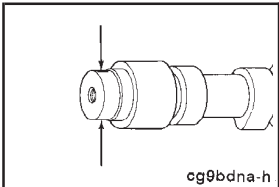
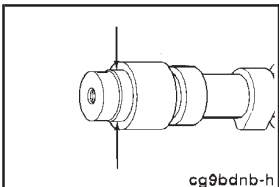
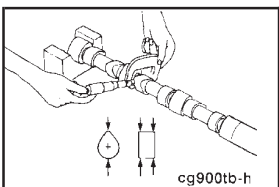
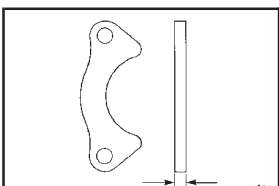
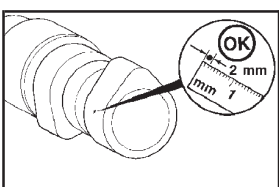
	Component or Assembly (Procedure)	Ref.No./Steps	Metric		U.S.
	<b>Connecting Rod - Twist:</b> • (With Bushing)		0.15 mm	MAX	0.006 in
	<b>Camshaft Bearing Journal Diameter</b>		53.962 mm 54.013 mm	MIN MAX	2.1245 in 2.1265 in
	<b>Camshaft Gear Mounting Surface O.D.</b>		41.575 mm 41.593 mm	MIN MAX	1.6368 in 1.6375 in
	<b>Camshaft Thrust Bearing Journal O.D.</b>		45.550 mm 45.750 mm	MIN MAX	1.7933 in 1.8012 in
	<b>Camshaft Diameter at Peak of the Lobe</b>	Intake Exhaust Fuel Transfer Pump	47.040 mm 47.492 mm 46.770 mm 47.222 mm 35.50 mm 36.26 mm	MIN MAX MIN MAX MIN MAX	1.852 in 1.870 in 1.841 in 1.859 in 1.398 in 1.428 in
	<b>Camshaft Thrust Plate Thickness</b>		9.4 mm 9.6 mm	MIN MAX	0.370 in 0.378 in
	<b>Camshaft Pitting Reuse Guidelines</b>	A single pit should not be greater than the area of a 2mm [0.079 in] diameter circle.			



Component or Assembly (Procedure)	Ref.No./Steps	Metric	U.S.
-----------------------------------	---------------	--------	------

Interconnection of pits is not allowable and is treated as one pit.

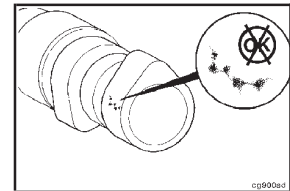

The total pits, when added together, should not exceed a circle of 6 mm [0.236 in].

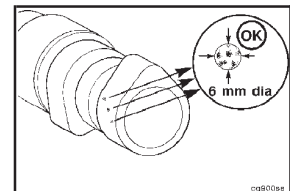

Only one pit is allowed within + or - 20 degrees of the nose of the camshaft lobe.

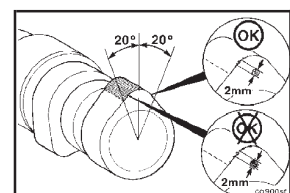

**Edge Deterioration (Breakdown):**

The area of edge deterioration should not be greater than the equivalent area of a 2 mm [0.079 in] circle within + or - 20 degrees of the nose of the camshaft lobe.

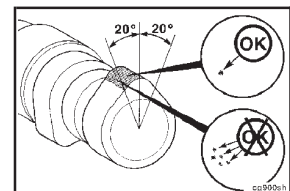

Outside of the + or - 20 degrees of the nose of the camshaft lobe, the areas of edge deterioration should not be greater than the equivalent area of a 6 mm [0.236 in] circle.

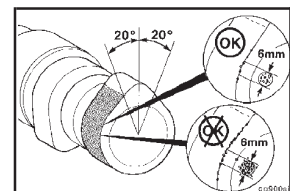

**Caution: The camshaft gear will be permanently distorted if overheated. The oven temperature should never exceed 177°C [350°F].**

Heat the camshaft gear for **non-bolted** 1991 and non-automotive 1994 camshafts in an oven at 149°C [300°F] for 45 minutes.

Heat the camshaft gear for **bolted** 1991 camshafts (steel gear) and **all** 1994 automotive to 177°C [350°F].

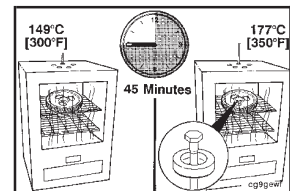

**Camshaft Gear Bore I.D.**

41.500 mm	MIN	1.6339 in
41.525 mm	MAX	1.6348 in

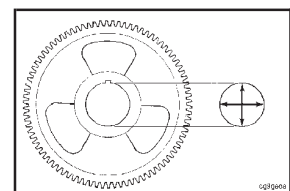

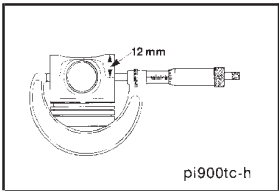
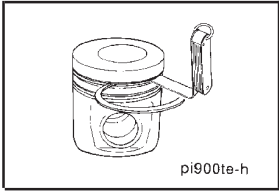
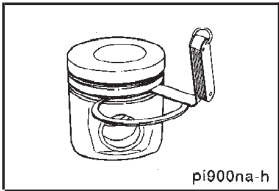
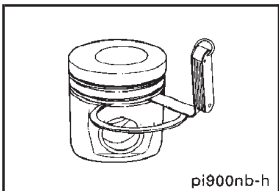
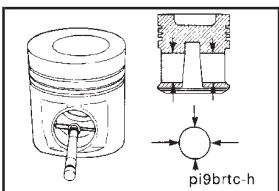
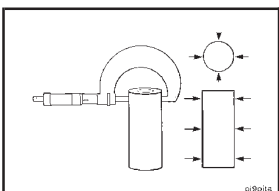
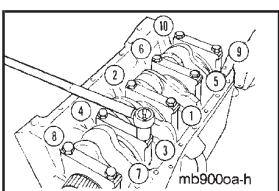
	Component or Assembly (Procedure)	Ref.No./Steps	Metric		U.S.
 <p>pi900tc-h</p>	<b>Piston Skirt O.D. (Worn Limit)</b>		101.823 mm 101.887 mm	MIN MAX	4.0088 in 4.0113 in
 <p>pi900te-h</p>	<b>Top Ring Side Clearance</b> • (Naturally Aspirated Only)		0.15 mm	MAX	0.006 in
 <p>pi900na-h</p>	<b>Intermediate Ring Side Clearance</b>		0.15 mm	MAX	0.006 in
 <p>pi900nb-h</p>	<b>Oil Control Ring Side Clearance</b>		0.13 mm	MAX	0.005 in
 <p>pi9btrc-h</p>	<b>Piston Pin Bore I.D.</b>		40.006 mm 40.025 mm	MIN MAX	1.5750 in 1.5758 in
 <p>pi901a</p>	<b>Piston Pin O.D.</b>		39.990 mm 40.003 mm	MIN MAX	1.5744 in 1.5749 in
 <p>mb900ca-h</p>	<b>Cylinder Block - Torque Values</b>				
	<b>Main Bearing Capscrew</b>	1 2 3	60 N•m 119 N•m 176 N•m		44 ft-lb 88 ft-lb 129 ft-lb

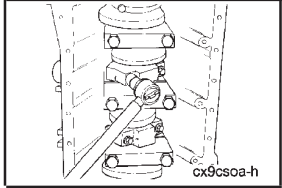
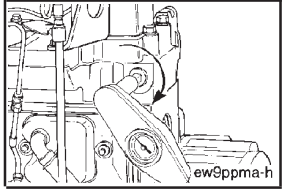
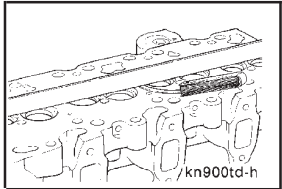
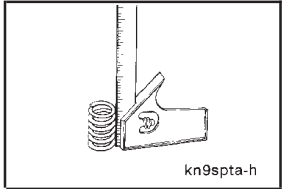
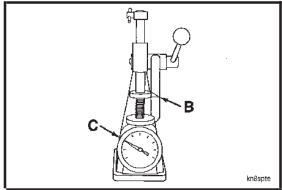
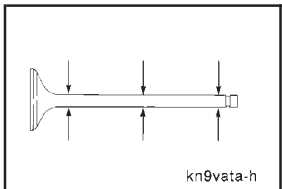
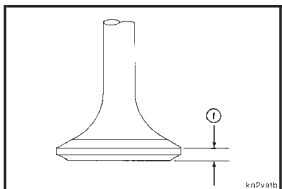
Component or Assembly (Procedure)	Ref.No./Steps	Metric	U.S.			
Connecting Rod Capscrews	1	35 N•m		26 ft-lb		
	2	70 N•m		52 ft-lb		
	3	100 N•m		74 ft-lb		
<b>Cylinder Block Pipe Plugs</b>						
Refer to "Pipe Plug Torque Value Table" at the rear of this section for torque value of various plug sizes.						
<b>Cylinder Head - Rebuild Specifications</b>						
<b>Cylinder Head Flatness</b>						
• End-to-End	4 Cylinder	0.203 mm	MAX	0.008 in		
	6 Cylinder	0.305 mm	MAX	0.012 in		
• Side-to-Side		0.076 mm	MAX	0.003 in		
<b>Valve Spring Free Height:</b>						
1991		55.63 mm	Nominal	2.190 in		
Exhaust Brake		70.64 mm	Nominal	2.781 in		
Marine/Rotator		56.00 mm	Nominal	2.208 in		
1994		60.00 mm	Nominal	2.362 in		
<b>Valve Spring Working Height and Load</b>						
	<b>Working Height (B)</b>	<b>Load For Working Height (C)</b>				
HD Exhaust Brake	48.97 mm	643.2 N	MIN	144.6 lbf		
	1.927 in	691.2 N	MAX	155.4 lbf		
Marine With Rotator	47.24 mm	282.7 N	MIN	63.5 lbf		
	1.859 in	323.1 N	MAX	72.6 lbf		
1994	49.25 mm	359 N	MIN	80.7 lbf		
	1.94 in	397 N	MAX	89.2 lbf		
All Others	49.25 mm	285 N	MIN	64.0 lbf		
	1.94 in	321 N	MAX	72.1 lbf		
<b>Valve Stem O.D.</b>		7.98 mm	MAX	0.3142 in		
<b>Valve Head Thickness at O.D.</b>	T	0.79 mm	MIN	0.031 in		

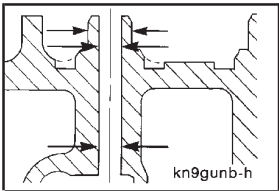
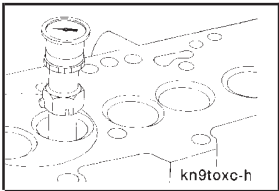
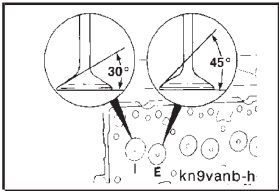
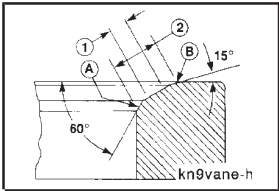
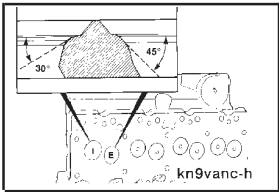
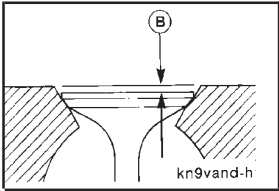
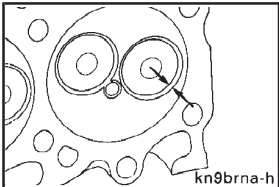
Component or Assembly (Procedure)	Ref.No./Steps	Metric	U.S.
 <p>kn9gunb-h</p>	Valve Guide Bore Diameter	8.019 mm 8.090 mm	MIN 0.3157 in MAX 0.3185 in
 <p>kn9toxc-h</p>	Valve Seat-to-Valve Guide Runout 360 Degrees	0.10 mm	MAX 0.004 in
 <p>kn9vanb-h</p>	Valve Face Grinding Angle Intake: Exhaust:	30 degrees 45 degrees	
 <p>kn9vane-h</p>	Valve Seat Width Limit Grind area (A) with a 60 degree stone and (B) with a 15 degree stone to center the seat on the valve face and obtain the valve seat width limits.	1 1.5 mm 2 2.0 mm	MIN 0.060 in MAX 0.080 in
 <p>kn9vanc-h</p>	Valve Seat Grinding Angle Intake: Exhaust:	30 degrees 45 degrees	
 <p>kn9vand-h</p>	Valve Recess in Cylinder Head	B 0.99 mm 1.52 mm	MIN 0.039 in MAX 0.060 in
 <p>kn9brna-h</p>	Valve Insert Bore Depth (Standard Insert)	10.30 mm 10.50 mm	MIN 0.4055 in MAX 0.4139 in

Component or Assembly (Procedure)	Ref.No./Steps	Metric	U.S.	
-----------------------------------	---------------	--------	------	--

**Valve Insert Bore I.D. (Standard Insert)**

46.987 mm	MIN	1.8499 in
47.013 mm	MAX	1.8509 in

**Note:** Refer to Cylinder Head - Oversize Valve Seat Installation for oversize valve insert dimensions.

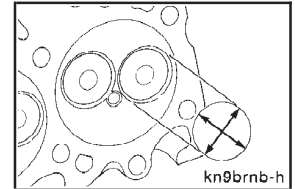

**Valve Seat Grinding Depth**

Seat grinding depth is the difference in dimension 'B' before and after grinding.

B	0.254 mm	MAX	0.010 in
---	----------	-----	----------

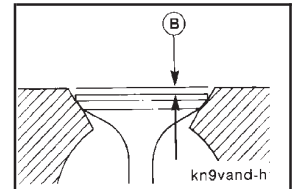

**Cylinder Head Cracks - Reuse Guidelines**

These guidelines apply only to cracks extending from the injector bore to the intake valve seats. Replace cylinder heads which exhibit valve bridge cracks in any other location.

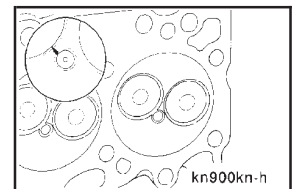

The reuse guidelines for a cylinder head with a crack extending from the injector bore to the intake valve seat are as follows:

If the crack does not extend into the valve seat, the head is reusable.

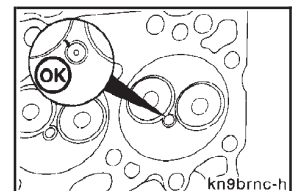

If the crack extends into or through the valve seat, the head must be repaired by installing a valve seat insert as described in the Alternative Repair Manual, Bulletin No. 3810234.

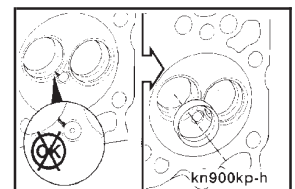

**Cylinder Head - Torque Values**

**Cylinder Head Mounting Capscrew (Tighten in the Sequence Shown)**

Step 1 - All	90 N•m	66 ft-lb
Step 2 - Recheck to	90 N•m	66 ft-lb
Step 3 (Long Capscrews Only)	120 N•m	90 ft-lb
Step 4 (Long Capscrews Only) - Recheck to	120 N•m	90 ft-lb
Step 5 - Rotate 90 degrees - All		

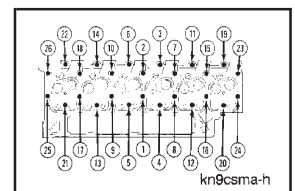

**Rocker Levers and Pedestals**

<b>Rocker Lever Bore Diameter</b>	19.000	MIN	0.7480 in
	19.051	MAX	0.7500 in

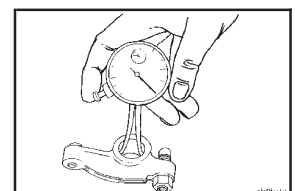

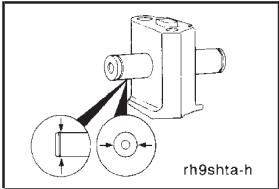
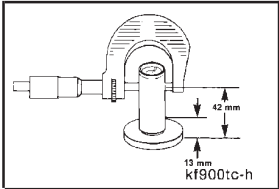
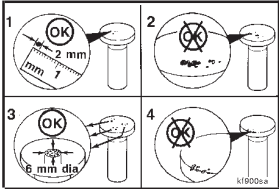
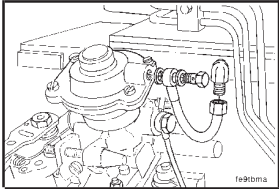
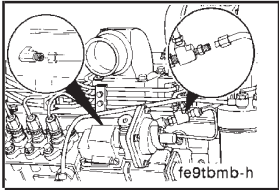
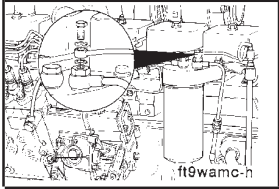
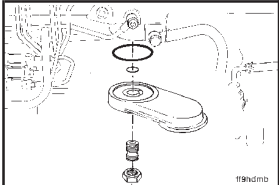
	Component or Assembly (Procedure)	Ref.No./Steps	Metric		U.S.
 <p>rh9shta-h</p>	<b>Pedestal Shaft Diameter</b>		18.938 mm 18.975 mm	MIN MAX	0.7456 in 0.7470 in
 <p>kf900tc-h</p>	<b>Tappet and Push Rods</b> <b>Valve Tappet Stem Diameter</b>		15.936 mm 15.977 mm	MIN MAX	0.627 in 0.629 in
 <p>kf900sa</p>	<p>Pit marks on the tappet face are acceptable. The following criteria defines the size of the pits allowed.</p> <ol style="list-style-type: none"> <li>1. A single pit cannot be greater than 2mm [0.078 in] diameter.</li> <li>2. Interconnection of pits is not allowed.</li> <li>3. Total pits when added together should not exceed 6 mm [0.236 inch] diameter or a total of 4 percent of the tappet face.</li> </ol>				
 <p>fe9tbma</p>	<b>Fuel System</b> <b>Air Fuel Control (AFC) Banjo Fitting (Rotary Pump)</b>		12 N•m		106 in-lb
 <p>fe9tbmb-h</p>	<b>Air Fuel Control (AFC) Banjo Fitting (In-Line Pump)</b> Pipe Adapter (in cylinder head) Tube Fittings		24 n•m 9 N•m		18 ft-lb 7 ft-lb
 <p>ft9wamc-h</p>	<b>Fuel Filter Banjo Fittings</b> Supply Line Fittings Return Line Fitting Vent Screw		24 N•m 13 N•m 9 N•m		18 ft-lb 10 ft-lb 7 ft-lb
 <p>ft9wamo</p>	<b>Fuel Filter Head Adapter</b>		32 N•m		24 ft-lb

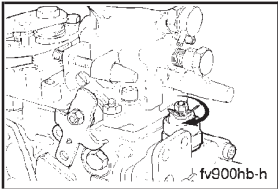
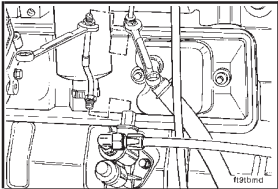
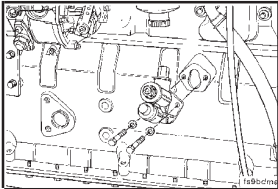
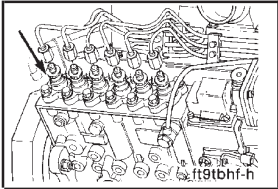
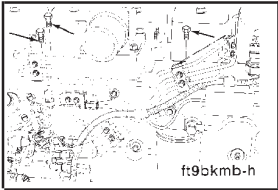
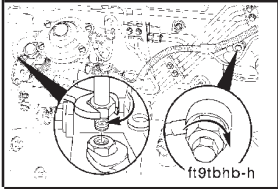
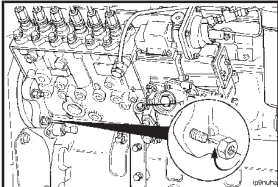
Component or Assembly (Procedure)	Ref.No./Steps	Metric	U.S.	
Fuel Pump Solenoid (Bosch VE) (CAV)		43 N•m 15 N•m	32 ft-lb 11 ft-lb	
Fuel Supply Line (Fuel Transfer Pump Outlet)		24 N•m	18 ft-lb	
Fuel Transfer Pump Mounting Capscrews		24 N•m	18 ft-lb	
High Pressure Fuel Line Fittings		24 N•m	18 ft-lb	
High Pressure Fuel Line Support Clamp Bracket		6 N•m 24 N•m	53 in-lb 18 ft-lb	
Injection Pump Supply Line Inlet		32 N•m	24 ft-lb	
Injection Pump Mounting Nuts Nippondenso Lucas, CAV, Bosch (Rotary), Stanadyne DB4 Bosch (In-Line)		43 N•m 30 N•m 43 N•m	32 ft-lb 22 ft-lb 32 ft-lb	

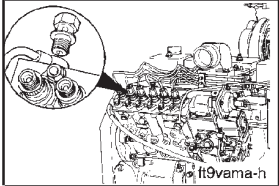
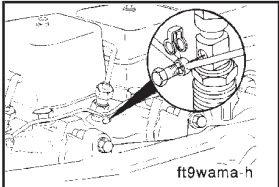
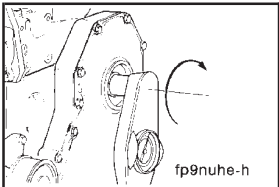
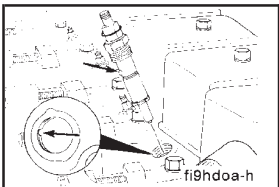
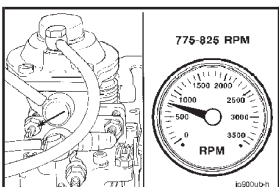
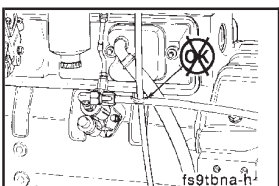
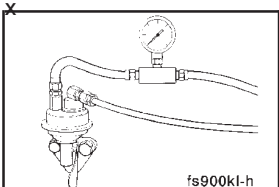
	Component or Assembly (Procedure)	Ref.No./Steps	Metric	U.S.
	Injection Pump Fuel Return Banjo Fitting		32 N•m	24 ft-lb
	<b>Injector Drain Manifold</b> Injector Banjo Filter Head Banjo Bracket		9 N•m 13 N•m 24 N•m	80 in-lb 10 ft-lb 18 ft-lb
	<b>Injection Pump Drive Gear Nut</b> Bosch (Rotary), Lucas CAV, Stanadyne DB4 Nippondenso Bosch (P3000, P7100)		65 N•m 123 N•m 165 N•m	48 ft-lb 92 ft-lb 122 ft-lb
	Injector		60 N•m	44 ft-lb
	<b>Engine Low Idle Speed (Typical)</b> (Refer to Engine Data Tag)		700 RPM 800 RPM	MIN MAX
	Fuel Transfer Pump Inlet Restriction		100 mm Hg	MAX 4 in Hg
	<b>Fuel Transfer Pump Outlet Pressure at Rated Speed</b> In-Line Injection Pump (Minimum) Rotary Injection Pump (Maximum)		172 kPa 70 kPa	25 psi 10 psi

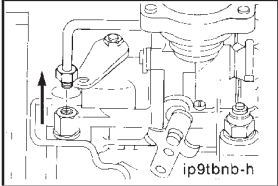
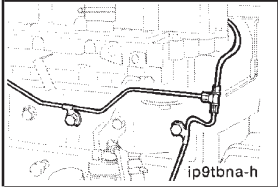
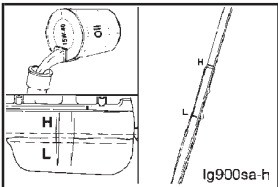
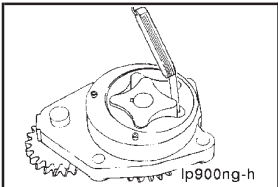
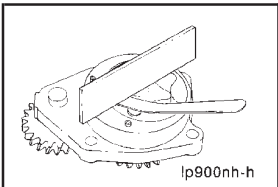
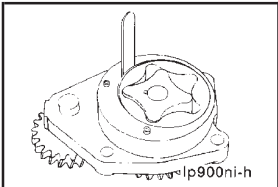
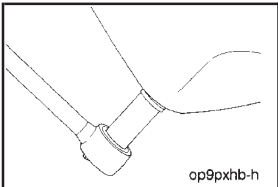

Component or Assembly (Procedure)	Ref.No./Steps	Metric	U.S.		
Fuel Injection Pump Inlet Pressure at Rated Speed Rotary In-Line (minimum)		0 to 70 kPa		0 to 10 psi	
		172 kPa		25 psi	
Fuel Injection Pump Return Line Restriction		518 mm Hg	MAX	20.4 in Hg	
<b>Lubricating Oil System - Specifications</b>					
Oil Pan Capacity	4 Cylinder	8.6 liters	Low	9 qts.	
		9.5 liters	High	10 qts.	
	6 Cylinder	12.4 liters	Low	13 qts.	
		14.2 liters	High	15 qts.	
	6 Cylinder Optional	9.5 liters	Low	10 qts.	
	10.4 liters	High	11 qts.		
Oil Pump Tip Clearance		0.1778 mm	MAX	0.007 in	
Oil Pump Port Plate Clearance		0.127 mm	MAX	0.005 in	
Oil Pump Body Bore Clearance		0.381 mm	MAX	0.015 in	
Oil Pan Drain Plug		80 N•m		60 ft-lb	

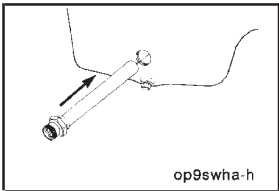
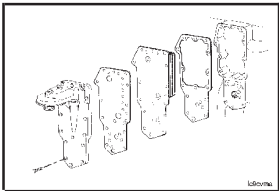
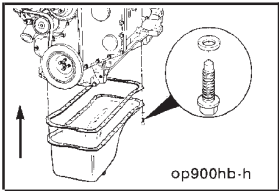
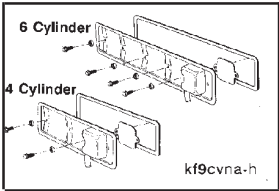
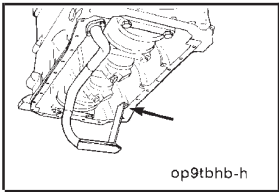
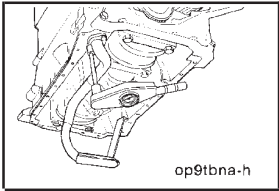
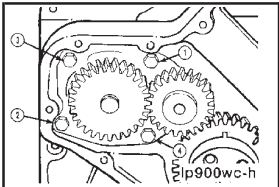
	Component or Assembly (Procedure)	Ref.No./Steps	Metric	U.S.
 <p>op9swha-h</p>	Oil Pan Heater Plug		80 N•m	60 ft-lb
	Oil Cooler Mounting Capscrews		24 N•m	18 ft-lb
 <p>op900hb-h</p>	Oil Pan Mounting Capscrews		24 N•m	18 ft-lb
 <p>6 Cylinder 4 Cylinder kf9cvna-h</p>	Tappet Cover Mounting Capscrews		24 N•m	18 ft-lb
 <p>op9tbhb-h</p>	Oil Pump Suction Tube Brace Capscrews		24 N•m	18 ft-lb
 <p>op9tbna-h</p>	Oil Pump Suction Tube Mounting Capscrews		24 N•m	18 ft-lb
 <p>op900wc-h</p>	Oil Pump Mounting Capscrews		24 N•m	18 ft-lb

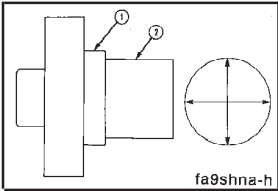
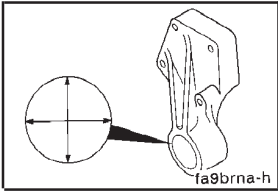
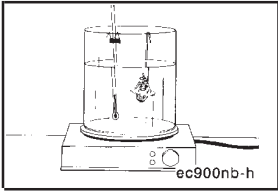
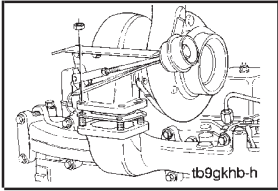
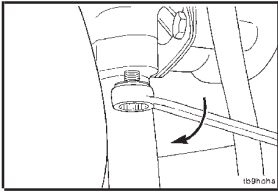
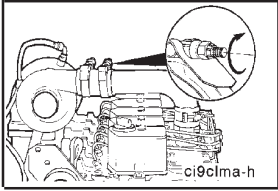
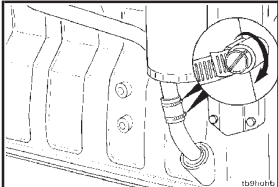
Component or Assembly (Procedure)	Ref.No./Steps	Metric		U.S.	
<b>Fan Hub - Specifications</b>					
Fan Hub Shaft O.D.	1	41.75 mm	MIN	1.644 in	
		42.25 mm	MAX	1.663 in	
	2	35.004 mm	MIN	1.3781 in	
		35.024 mm	MAX	1.3789 in	
Hub Bearing Bore I.D.		63.938 mm	MIN	2.5172 in	
		63.956 mm	MAX	2.5179 in	
<b>Thermostat, Coolant Operating Temperature</b>					
• Initial Opening Temperature		80°C	MIN	176°F	
		83°C	MAX	182°F	
• Fully Open Temperature		95°C	MAX	203°F	
• Maximum Opening Distance		6.6 mm	MAX	0.260 in	
<b>Combustion Air System</b>					
Turbocharger Mounting Nuts		43 N•m		32 ft-lb	
Turbocharger Oil Drain Tube Mounting Capscrew		24 N•m		18 ft-lb	
Turbocharger Air Crossover Hose Clamps		5 N•m		44 in-lb	
Turbocharger Oil Drain Line Hose Clamps		6 N•m		53 in-lb	

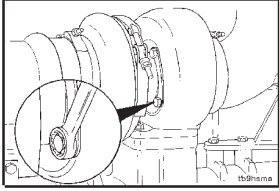
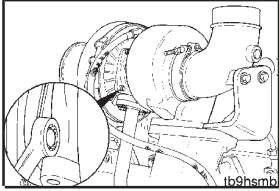
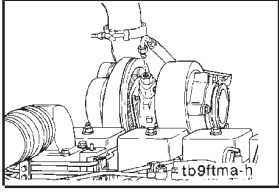
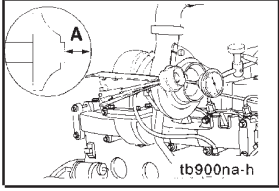
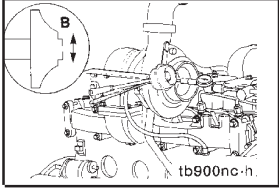
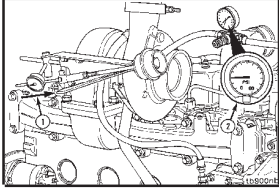
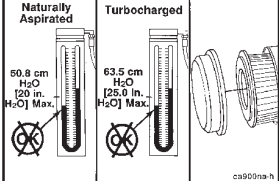
Component or Assembly (Procedure)	Ref.No./Steps	Metric	U.S.																								
	Turbocharger Turbine Housing Capscrews	20 N•m	15 ft-lb																								
	<b>Turbocharger Compressor Housing Capscrews</b> <ul style="list-style-type: none"> <li>Diffuser Plate Capscrews</li> <li>V Band Clamp (Silver Plated Nut)</li> </ul>	8.5 N•m 8.5 N•m	75 in-lb 75 in-lb																								
	Turbocharger Oil Supply Line Connection	35 N•m	26 ft-lb																								
	<b>Air Intake System</b>																										
	Turbocharger Axial Clearance	*0.10 mm 0.16 mm	MIN MAX 0.004 in 0.006 in																								
		**0.03 mm 0.08 mm	MIN MAX 0.001 in 0.003 in																								
		* For turbochargers with a serial number before 840638. ** For turbochargers with a serial number after and including 840638.																									
	Turbocharger Radial Clearance	0.30 mm 0.46 mm	MIN MAX 0.012 in 0.018 in																								
	Wastegate Rod Travel at the Following Wastegate Applied Pressure	0.33 mm 1.3 mm	Min Max 0.013 in 0.050 in																								
	<table border="1"> <thead> <tr> <th>Engine Year</th> <th>HP Rating</th> <th>Application</th> <th>Wastegate Applied Pressure</th> </tr> </thead> <tbody> <tr> <td>1991</td> <td>110</td> <td>Automotive (4B)</td> <td>133 kPa [19.3 psi]</td> </tr> <tr> <td>1991</td> <td>190-230</td> <td>Automotive</td> <td>153 kPa [22.2 psi]</td> </tr> <tr> <td>1994</td> <td>160-175</td> <td>Automotive</td> <td>133 kPa [19.3 psi]</td> </tr> <tr> <td>1994</td> <td>190-230</td> <td>Automotive</td> <td>198 kPa [28.7 psi]</td> </tr> <tr> <td>1994</td> <td>All</td> <td>Industrial</td> <td>191 kPa [27.7 psi]</td> </tr> </tbody> </table>	Engine Year	HP Rating	Application	Wastegate Applied Pressure	1991	110	Automotive (4B)	133 kPa [19.3 psi]	1991	190-230	Automotive	153 kPa [22.2 psi]	1994	160-175	Automotive	133 kPa [19.3 psi]	1994	190-230	Automotive	198 kPa [28.7 psi]	1994	All	Industrial	191 kPa [27.7 psi]		
Engine Year	HP Rating	Application	Wastegate Applied Pressure																								
1991	110	Automotive (4B)	133 kPa [19.3 psi]																								
1991	190-230	Automotive	153 kPa [22.2 psi]																								
1994	160-175	Automotive	133 kPa [19.3 psi]																								
1994	190-230	Automotive	198 kPa [28.7 psi]																								
1994	All	Industrial	191 kPa [27.7 psi]																								
	<b>Intake Air Restriction (Rated Speed and Load)</b> <ul style="list-style-type: none"> <li>Naturally Aspirated Engine</li> <li>Turbocharged Engine</li> </ul>	508 mm H <sub>2</sub> O 635 mm H <sub>2</sub> O	MAX MAX 20 in H <sub>2</sub> O 25 in H <sub>2</sub> O																								

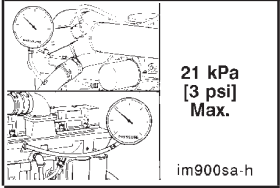
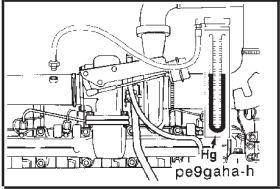
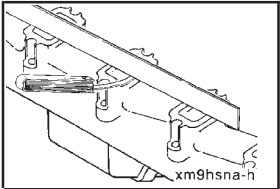
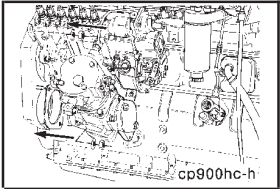
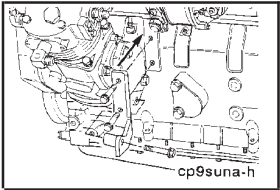
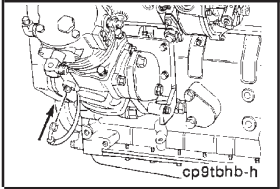
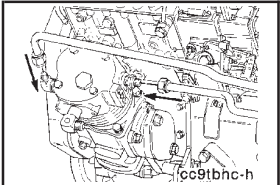
Component or Assembly (Procedure)	Ref.No./Steps	Metric		U.S.	
<b>Charge Air Cooler</b> Differential Pressure Across Cooler		21 kPa	Max	3 psi	
<b>Exhaust Air Restriction (Rated Speed and Load)</b> (Naturally aspirated engines are checked at rated speed and no load). Automotive With Catalyst Automotive Without Catalyst		76.2 mm Hg 114.3 mm Hg 152.4 mm Hg	MAX MAX MAX	3 in Hg 4.5 in Hg 6.0 in Hg	
<b>Exhaust Manifold Flatness</b>		0.10 mm	MAX	0.004 in	
<b>Compressed Air System Torque Values</b>					
<b>Air Compressor Mounting Nuts</b>		77 N•m		57 ft-lb	
<b>Air Compressor Support Capscrews</b>		24 N•m		18 ft-lb	
<b>Air Compressor Oil Supply Line</b>		15 N•m		12 ft-lb	
<b>Air Compressor Coolant Lines</b>		24 N•m		18 ft-lb	

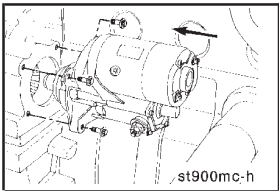
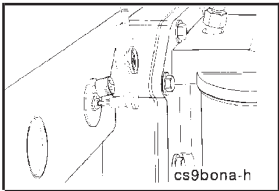
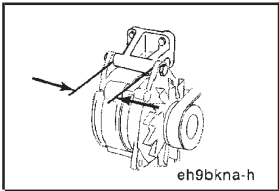
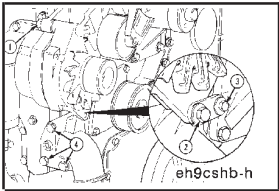
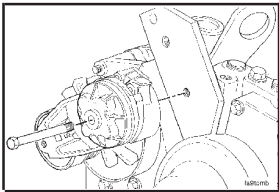
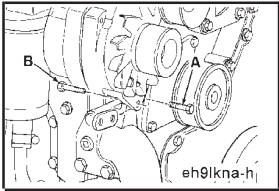
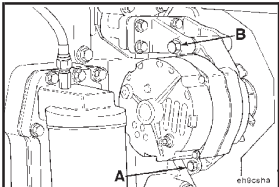
Component or Assembly (Procedure)	Ref.No./Steps	Metric	U.S.
 <p>st900mc-h</p>	<p><b>Electrical System</b> Starting Motor Mounting Capscrews</p>	43 N•m	32 ft-lb
 <p>cs9bona-h</p>	<p>Coolant Heater</p>	12 N•m	108 in-lb
 <p>eh9bkna-h</p>	<p><b>Alternator Mounting Bracket Dimension</b> Delco 10/15SI Motorola 100 Amp Delco 20/27SI Lucas</p>	<p>55.72 mm 81 mm 98 mm 78 mm</p>	<p>2 3/16 in 3 3/16 in 3 7/8 in 3 in</p>
 <p>eh9cshb-h</p>	<p><b>Alternator Assembly Torque Sequence</b></p>	<ol style="list-style-type: none"> <li>1. Alternator-to-alternator bracket capscrew.</li> <li>2. Lower brace-to-alternator capscrew.</li> <li>3. Alternator-to-water inlet capscrew.</li> <li>4. Water inlet-to-block capscrews.</li> </ol>	
 <p>st900mc-h</p>	<p>Belt Tensioner Capscrew</p>	43 N•m	32 ft-lb
 <p>eh9lkna-h</p>	<p><b>Alternator Link</b> 8 mm Capscrew 10 mm Capscrew</p>	<p>A 24 N•m B 43 N•m</p>	<p>18 ft-lb 32 ft-lb</p>
 <p>eh9cshb-h</p>	<p><b>Alternator Mounting Bolt</b> Delco 10 to 15SI, Lucas, Motorola and Bosch Delco 20SI, 27SI, 29SI</p>	<p>B 43 N•m 80 N•m</p>	<p>32 ft-lb 59 ft-lb</p>

Component or Assembly (Procedure)	Ref.No./Steps	Metric	U.S.
-----------------------------------	---------------	--------	------

Alternator Bracket Mounting Capscrews  
8 mm

24 N•m

18 ft-lb

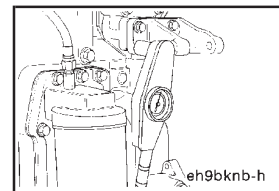

Alternator Pulley Nut

80 N•m

59 ft-lb

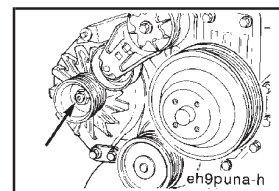

**Batteries - State of Charge**

Specific Gravity  
at 27°C [80°F]  
1.260 to 1.280  
1.230 to 1.250  
1.200 to 1.220  
1.170 to 1.190  
1.110 to 1.130

State of  
Charge  
100%  
75%  
50%  
25%  
Discharged

Battery State of Charge	Specific Gravity @ 27°C [80°F]
100%	1.260-1.280
75%	1.230-1.250
50%	1.200-1.220
25%	1.170-1.190
Discharged	1.110-1.130

**Engine Testing - Test Specifications**

**Note:** The specifications and instructions for testing the engine are provided in the Shop Manual, Bulletin No. 3810206. Refer to Engine Testing - Group 14, Page 14-1.

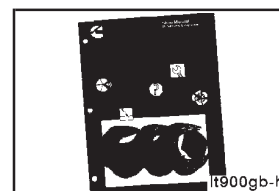

### Drive Belt Tension

SAE Belt Size	Belt Tension Gauge Part No.		Belt Tension New		Belt Tension Range Used*	
	Click-type	Burroughs	N	lbf	N	lbf
.380 in.	3822524		620	140	270 to 490	60 to 110
.440 in.	3822524		620	140	270 to 490	60 to 110
1/2 in.	3822524	ST-1138	620	140	270 to 490	60 to 110
11/16 in.	3822524	ST-1138	620	140	270 to 490	60 to 110
3/4 in.	3822524	ST-1138	620	140	270 to 490	60 to 110
7/8 in.	3822524	ST-1138	620	140	270 to 490	60 to 110
4 rib	3822524	ST-1138	620	140	270 to 490	60 to 110
5 rib	3822524	ST-1138	670	150	270 to 530	60 to 120
6 rib	3822525	ST-1293	710	160	290 to 580	65 to 130
8 rib	3822525	ST-1293	890	200	360 to 710	80 to 160
10 rib	3822525	3823138	1110	250	440 to 890	100 to 200
12 rib	3822525	3823138	1330	300	530 to 1070	120 to 240

\* A belt is considered used if it has been in service for ten minutes or longer.

\* If used belt tension is less than the minimum value, tighten the belt to the maximum used belt value.



FRACTION, DECIMAL, MILLIMETER CONVERSIONS

8 THS.	16 THS.	32 NDS.	64 THS.	INCHES	MM	8 THS.	16 THS.	32 NDS.	64 THS.	INCHES	MM
			1	0.0156	0.397				33	0.5156	13.097
		1		0.0313	0.794			17		0.5313	13.494
			3	0.0469	1.191				35	0.5469	13.891
	1			0.0625	1.588		9			0.5625	14.288
			5	0.0781	1.984				37	0.5781	14.684
		3		0.0938	2.381			19		0.5938	15.081
			7	0.1094	2.778				39	0.6094	15.478
1				0.1250	3.175	5				0.6250	15.875
			9	0.1406	3.572				41	0.6406	16.272
		5		0.1563	3.969			21		0.6563	16.669
			11	0.1719	4.366				43	0.6719	17.066
	3			0.1875	4.763		11			0.6875	17.463
			13	0.2031	5.159				45	0.7031	17.859
		7		0.2188	5.556			23		0.7188	18.256
			15	0.2344	5.953				47	0.7344	18.653
1/4				0.2500	6.350	3/4				0.7500	19.050
			17	0.2656	6.747				49	0.7656	19.447
		9		0.2813	7.144			25		0.7813	19.844
			19	0.2969	7.541				51	0.7969	20.241
	5			0.3125	7.938		13			0.8125	20.638
			21	0.3281	8.334				53	0.8281	21.034
		11		0.3438	8.731			27		0.8438	21.431
			23	0.3594	9.128				55	0.8594	21.828
3				0.3750	9.525	7				0.8750	22.225
			25	0.3906	9.922				57	0.8906	22.622
		13		0.4063	10.319			29		0.9063	23.019
			27	0.4219	10.716				59	0.9219	23.416
	7			0.4375	11.113		15			0.9375	23.813
			29	0.4531	11.509				61	0.9531	24.209
		15		0.4688	11.906			31		0.9688	24.606
			31	0.4844	12.303				63	0.9844	25.003
1/2				0.5000	12.700	1 IN.				1.0000	25.400

CONVERSION FACTOR: 1 INCH = 25.4MM

**Weight and Measures - Conversion Factors**

QUANTITY	U.S. CUSTOMARY		METRIC		FROM U.S. CUSTOMARY TO METRIC MULTIPLY BY	FROM METRIC TO U.S. CUSTOMARY MULTIPLY BY
	Unit Name	Abbr.	Unit Name	Abbr.		
Area	sq. inch	in <sup>2</sup>	sq. millimeters	mm <sup>2</sup>	645.16	0.001550
			sq. centimeters	cm <sup>2</sup>	6.452	0.155
	sq. foot	ft <sup>2</sup>	sq. meter	m <sup>2</sup>	0.0929	10.764
Fuel Consumption	pounds per horsepower hour	lb/hp-hr	grams per kilowatt hour	g/kw-hr	608.277	0.001645
Fuel Performance	miles per gallon	mpg	kilometers per liter	km/l	0.4251	2.352
	gallons per mile	gpm	liters per kilometer	l/km	2.3527	0.4251
Force	pounds force	lbf	Newton	N	4.4482	0.224809
Length	inch	in	millimeters	mm	25.40	0.039370
	foot	ft	millimeters	mm	304.801	0.00328
Power	horsepower	hp	kilowatt	kw	0.746	1.341
Pressure	pounds force per sq. in	psi	kilopascal	kPa	6.8948	0.145037
	inches of mercury	in Hg	kilopascal	kPa	3.3769	0.29613
	inches of water	in H <sub>2</sub> O	kilopascal	kPa	0.2488	4.019299
	inches of mercury	in Hg	millimeters of mercury	mm Hg	25.40	0.039370
	inches of water	in H <sub>2</sub> O	millimeters of water	mm H <sub>2</sub> O	25.40	0.039370
	bars	bars	kilopascals	kPa	100.001	0.00999
	bars	bars	millimeters of mercury	mm Hg	750.06	0.001333
Temperature	fahrenheit	°F	centigrade	°C	(°F-32) ÷ 1.8	(1.8 x °C) + 32
Torque	pound force per foot	ft lb	Newton-meter	N•m	1.35582	0.737562
	pound force per inch	in lb	Newton-meter	N•m	0.113	8.850756
Velocity	miles/hour	mph	kilometers/hour	kph	1.6093	0.6214
Volume: liquid displacement	gallon (U.S.)	gal.	liter	l	3.7853	0.264179
	gallon (Imp*)	gal.	liter	l	4.546	0.219976
	cubic inch	in <sup>3</sup>	liter	l	0.01639	61.02545
	cubic inch	in <sup>3</sup>	cubic centimeter	cm <sup>3</sup>	16.387	0.06102
Weight (mass)	pounds (avoir.)	lb	kilograms	kg	0.4536	2.204623
Work	British Thermal Unit	BTU	joules	j	1054.5	0.000948
	British Thermal Unit	BTU	kilowatt-hour	kw-hr	0.000293	3414
	horsepower hours	hp-hr	kilowatt-hour	kw-hr	0.746	1.341

### Newton-Meter to Foot-Pound Conversion Chart

N•m	ft-lb	N•m	ft-lb	N•m	ft-lb
1	8.850756 in-lb	55	41	155	114
5	44 in-lb	60	44	160	118
6	53 in-lb	65	48	165	122
7	62 in-lb	70	52	170	125
8	71 in-lb	75	55	175	129
9	80 in-lb	80	59	180	133
10	89 in-lb	85	63	185	136
1	0.737562 ft-lb	90	66	190	140
12	9	95	70	195	144
14	10	100	74	200	148
15	11	105	77	205	151
16	12	110	81	210	155
18	13	115	85	215	159
20	15	120	89	220	162
25	18	125	92	225	165
30	22	130	96	230	170
35	26	135	100	235	173
40	30	140	103	240	177
45	33	145	107	245	180
50	37	150	111	250	184

NOTE: To convert from Newton-Meters to Kilogram-Meters divide Newton-Meters by 9.803.

**Capscrew Markings and Torque Values - U.S. Customary**

<b>SAE Grade Number</b>	<b>5</b>	<b>8</b>
-------------------------	----------	----------

**Capscrew Head Markings**

These are all SAE Grade 5 (3) line

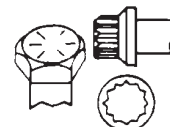

Capscrew Body Size	Capscrew Torque - Grade 5 Capscrew				Capscrew Torque - Grade 8 Capscrew			
	Cast Iron		Aluminum		Cast Iron		Aluminum	
	N•m	ft-lb	N•m	ft-lb	N•m	ft-lb	N•m	ft-lb
1/4 - 20	9	7	8	6	15	11	8	6
- 28	12	9	9	7	18	13	9	7
5/16 - 18	20	15	16	12	30	22	16	12
- 24	23	17	19	14	33	24	19	14
3/8 - 16	40	30	25	20	55	40	25	20
- 24	40	30	35	25	60	45	35	25
7/16 - 14	60	45	45	35	90	65	45	35
- 20	65	50	55	40	95	70	55	40
1/2 - 13	95	70	75	55	130	95	75	55
- 20	100	75	80	60	150	110	80	60
9/16 - 12	135	100	110	80	190	140	110	80
- 18	150	110	115	85	210	155	115	85
5/8 - 11	180	135	150	110	255	190	150	110
- 18	210	155	160	120	290	215	160	120
3/4 - 10	325	240	255	190	460	340	255	190
- 16	365	270	285	210	515	380	285	210
7/8 - 9	490	360	380	280	745	550	380	280
- 14	530	390	420	310	825	610	420	310
1 - 8	720	530	570	420	1100	820	570	420
- 14	800	590	650	480	1200	890	650	480

### Capscrew Markings and Torque Values

**⚠ Caution:** When replacing capscrews, always use a capscrew of the same measurement and strength as the capscrew being replaced. Using the wrong capscrews can result in engine damage.

Metric capscrews and nuts are identified by the grade number stamped on the head of the capscrew or on the surface of the nuts. U.S. Customary capscrews are identified by radial lines stamped on the head of the capscrew.

The following examples indicate how capscrews are identified:

Metric - M8-1.25 X 25			U.S. Customary [5/16 X 18 X 1-1/2]		
M8	1.25	25	5/16	18	1-1/2
Major	Distance	Length	Major	Number	Length
Thread	Between	in	Thread	Threads	in
Diameter in	Threads in	Millimeters	Diameter	per Inch	Inches
Millimeters	Millimeters		in Inches		

**NOTES:**

1. **Always** use the torque values listed in the following tables when specific torque values are **not** available.
2. Do **not** use the torque values in place of those specified in other sections of this manual.
3. The torque values in the table are based on the use of lubricated threads.
4. When the ft-lb value is less than 10, give consideration to converting the ft-lb value to in-lb to obtain a better torque with an in-lb torque wrench. Example: 6 ft-lb equals 72 in-lb.

### Pipe Plug Torque Values

Size		Torque		Torque	
Thread	Actual Thread O.D.	In Aluminum Components		In Cast Iron or Steel Components	
in	in	N•m	ft-lb	N•m	ft-lb
1/16	0.32	5	45 in-lb	15	10
1/8	0.41	15	10	20	15
1/4	0.54	20	15	25	20
3/8	0.68	25	20	35	25
1/2	0.85	35	25	55	40
3/4	1.05	45	35	75	55
1	1.32	60	45	95	70
1-1/4	1.66	75	55	115	85
1-1/2	1.90	85	65	135	100

### Tap-Drill Chart - U.S. Customary and Metric

#### General Information

NOTE ON SELECTING TAP-DRILL SIZES: The tap drill sizes shown on this card give the theoretical tap drill size for approximately 60% and 75% of full thread depth. Generally, it is recommended that drill sizes be selected in the 60% range as these sizes will provide about 90% of the potential holding power. Drill sizes in the 75% range are recommended for shallow hole tapping (less than 1 1/2 times the hole diameter) in soft metals and mild steel.

Tap Size		Drill Size	Tap Size		Drill Size	Tap Size		Drill Size	Tap Size		Drill Size
60%	75%		60%	75%		60%	75%		60%	75%	
		48			4.40mm						13.25mm
		1.95mm		12-24	16						17/32
		5/64			4.50mm						13.50mm
	3-48	47			15						13.75mm
		2.00mm		M5.5x.9	4.60mm						35/64
	M2.5x.45	2.05mm		12-28	14						14.00mm
		46			13						14.25mm
3-48		45			4.70mm						9/16
	3056	2.10mm		M5.5x.9	4.75mm						14.50mm
		2.15mm		12-28	3/16						37/64
M2.5x.45	M2.6x.45	44			12						14.75mm
3-56	4-36	2.20mm			4.80mm						15.00mm
		2.25mm			11						19.32
M2.6x.45		43			4.90mm						15.25mm
4-36		2.30mm			10						39/64
		2.35mm			9						15.50mm
4-40	4-48	42			5.00mm						15.75mm
		3/32			8						5/8
	M3x.6	2.40mm			5.10mm						16.00mm
4-48		41			7						16.25mm
		2.45mm			13/64						41/64
		40			6						16.50mm
M3x.6	M3x.5	2.50mm			5.20mm						21/32
		39			5						16.75mm
	5-40	38			5.25mm						17.00mm
		2.60mm			5.30mm						43/64
M3x.5		37			4						17.25mm
5-40	5-44	2.70mm			5.40mm						11/16
		36			3						17.50mm
5-44	6-32	2.75mm			5.50mm						45/64
		7/64			7/32						18.00mm
		35			2						18.25mm
		2.80mm			5.70mm						23/32
		34			5.75mm						18.50mm
6-32	6-40	33			1						47/64
	M3.5x6	2.90mm			5.80mm						18.75mm
		32			5.90mm						19.00mm
		3.00mm			A						3/4
M3.5x6		31			15/64						19.25mm
6-40		3.10mm			6.00mm						49/64
		1/8			B						19.50mm
		3.20mm			6.10mm						25/32
		3.25mm			C						19.75mm
	M4x.75	30			6.20mm						20.00mm
		3.30mm			D						51/64
	M4x.7	3.40mm			6.25mm						20.25mm
M4x.75	8-32	29			6.30mm						20.50mm
M4x.7		3.50mm			E						13/16
		28			1/4						20.75mm
8-32		9/64			6.40mm						21.00mm
		3.60mm			6.50mm						53/64
8-36		27			F						21.25mm
		3.70mm			6.60mm						27/32
		26			G						21.50mm
		3.75mm			6.70mm						21.75mm
	M4.5x.75	25			17/64						55/64
	10-24	3.80mm			6.75mm						22.00mm
		24			H						7/8
M4.5x.75		3.90mm			6.80mm						22.25mm
		23			6.90mm						22.50mm
		5/32			I						57/64
		22			7.00mm						22.75mm
		4.00mm			J						23.00mm
	M5x1	21			7.10mm						29/32
	10-32	20			K						23.25mm
		4.10mm			9/32						59/64
	M5x.9	19			7.20mm						23.50mm
	M5x.8	4.20mm			7.25mm						23.75mm
M5x1		19			7.30mm						15/16
10-32		4.25mm			L						
M5x.9		4.30mm			7.40mm						
M5x.8		18			M						
		11/64									
		17									

# Section L - Service Literature

## Section Contents

	<b>Page</b>
<b>Additional Service Literature .....</b>	<b>L-2</b>
<b>Service Literature Ordering Location .....</b>	<b>L-3</b>
<b>Service Publications Order Form.....</b>	<b>L-4</b>



**Cummins Engine Company, Inc.**  
Box 3005  
Columbus, Indiana, U.S.A., 47202  
Cable: CUMDIEX COLUMBUS

Registered Office  
**Cummins Engine Company, Ltd.**  
46-50 Coombe Road  
New Malden,  
Surrey KT3 4QL,  
England  
Cable: CUMEUR G  
Registration No. 573951 England

Copyright© 1994  
Cummins Engine Company, Inc.

**Additional Service Literature**

The following publications can be purchased by filling in and mailing the Service Literature Order Form:

<b>Bulletin No.</b>	<b>Title Of Publication</b>
3666087	Troubleshooting and Repair Manual
3666017	B Series Engine Shop Manual
3810234	B Series Alternative Repair
3666029	4B Series Standard Repair Times
3666028	6B Series Standard Repair Times

## Service Literature Ordering Location

### Region

United States and Canada

### Ordering Location

Cummins Distributors

or

Cummins Engine Co., Inc.  
Publishing Services CMC 40924  
Box 3005

Columbus, IN 47202-3005

U.K., Europe, Mid-East, Africa,  
and Eastern European Countries

Cummins Engine Co., Ltd.

Royal Oak Way South

Daventry

Northants, NN11 5NU, England

South and Central America  
(excluding Brazil and Mexico)

Cummins Americas, Inc.

16085 N.W. 52nd Avenue

Hialeah, FL 33104

Brazil and Mexico

Cummins Engine Co., Inc.

International Parts Order Dept., MC 40931

Box 3005

Columbus, IN 47202-3005

Far East (excluding  
Australia and New Zealand)

Cummins Diesel Sales Corp.

Literature Center

8 Tanjong Penjuru

Jurong Industrial Estate

Singapore

Australia and New Zealand

Cummins Diesel Australia

Maroondah Highway, P.O.B. 139

Ringwood 3134

Victoria, Australia

**Obtain current price information from your local Cummins Distributor or (for U.S.A.) by calling Cummins Toll Free Number 1-800-DIESELS (1-800-343-7357).**

## Service Literature Order Form

Use this form for prompt handling of your literature order from the factory.

Item	Bulletin Number	Title of Publication	Quantity	U.S. Price Each	Amount
1				\$	\$
2					
3					
4					
5					
6					
<b>Publications Total</b>					
<b>Indiana Residents: Add 5% Sales Tax</b>					
<b>Handling &amp; Shipping Chg: No. Items X \$1.50 =</b>					
<b>Order Total</b>					\$

Payment Enclosed. Make certified check or money order payable to Cummins Engine Co.

Please ship C.O.D. (U.S.A. only)

Prices subject to change without notice.

For factory orders, mail the Service Publications Order Form along with your ship-to address to:  
Cummins Engine Co., Inc., Publishing Services (MC 41407)  
Box 3005, Columbus, IN 47202-3005.

**FROM:**

Name: \_\_\_\_\_

Street Address: \_\_\_\_\_

City: \_\_\_\_\_ State: \_\_\_\_\_ Zip Code: \_\_\_\_\_

Country: \_\_\_\_\_

**SHIP TO: (Name and address where literature is to be shipped)**

Name: \_\_\_\_\_

Street Address: \_\_\_\_\_

City: \_\_\_\_\_ State: \_\_\_\_\_ Zip Code: \_\_\_\_\_

Country: \_\_\_\_\_

# Section C - Component Manufacturers

## Section Contents

	Page
<b>United States and United Kingdom Offices .....</b>	<b>C-2</b>
Air Cylinders .....	C-2
Air Heaters .....	C-2
Air Starting Motors .....	C-2
Alternators .....	C-2
Auxiliary Brakes .....	C-3
Belts .....	C-3
Clutches .....	C-3
Coolant Heaters .....	C-3
Drive Plates .....	C-3
Electric Starting Motors .....	C-3
Fan Clutches .....	C-4
Fans .....	C-4
Filters .....	C-4
Flexplates .....	C-4
Fuel Warmers .....	C-5
Gauges .....	C-5
Governors .....	C-5
Hydraulic and Power Steering Pumps .....	C-5
Oil Heaters .....	C-6
Safety Controls .....	C-6
Torque Converters .....	C-6

**United States and United Kingdom Offices**

**NOTE:** The following list contains addresses and telephone numbers of suppliers of accessories used on Cummins engines. Suppliers may be contacted directly for any specifications **not** covered in this manual.

**Air Cylinders**

Bendix Ltd.  
Douglas Road  
Kingswood  
Bristol  
England  
Telephone: 0272-671881

Catching Engineering  
2101 Roberts Drive  
Broadview, IL 60153  
Telephone: (312) 344-2334

**Air Heaters**

Fleetguard, Inc.  
Route 8  
Cookeville, TN 38501  
Telephone: (615) 526-9551

Kim Hotstart Co.  
West 917 Broadway  
Spokane, WA 99210  
Telephone: (509) 534-6171

**Air Starting Motors**

Ingersoll Rand  
Chorley New Road  
Horwich  
Bolton  
Lancashire  
England  
BL6 6JN  
Telephone: 0204-65544

Ingersoll-Rand Engine  
Starting Systems  
888 Industrial Drive  
Elmhurst, IL 60126  
Telephone: (312) 530-3800

Start Master  
Air Starting Systems  
A Division of Sycon Corporation  
P. O. Box 491  
Marion, OH 43302  
Telephone: (614) 382-5771

**Alternators**

Robert Bosch Ltd.  
P.O. Box 98  
Broadwater Park  
North Orbital Road  
Denham  
Uxbridge  
Middlesex UD9 5HG  
England  
Telephone: 0895-833633

Butec Electric  
Cleveland Road  
Leyland  
PR5 1XB  
England  
Telephone: 0744-21663

C.A.V. Electrical Equipment  
P.O. Box 36  
Warple Way  
London  
W3 7SS  
England  
Telephone: 01-743-3111

A.C. Delco Components Group  
Civic Offices  
Central Milton Keynes  
MK9 3EL  
England  
Telephone: 0908-66001

Delco-Remy  
P.O. Box 2439  
Anderson, IN 46018  
Telephone: (317) 646-7838

Leece-Neville Corp.  
1374 E. 51st St.  
Cleveland, OH 44013  
Telephone: (216) 431-0740

**Auxiliary Brakes**

The Jacobs Manufacturing Company  
Vehicle Equipment Division  
22 East Dudley Town Road  
Bloomfield, CT 06002  
Telephone: (203) 243-1441

**Belts**

Dayco Rubber U.K.  
Sheffield Street  
Stockport  
Cheshire  
SK4 1RV  
England  
Telephone: 061-432-5163

T.B.A. Ind. Products  
P.O. Box 77  
Wigan  
Lancashire  
WN2 4XQ  
England  
Telephone: 0942-59221

Dayco Corp.  
Belt Technical Center  
P.O. Box 3258  
Springfield, MO 65804  
Telephone: (417) 881-7440

Gates Rubber Company  
5610 Crawfordsville Road  
Suite 2002  
Speedway, IN 46224  
Telephone: (317) 248-0386

Goodyear Tire and  
Rubber Company  
49 South Franklin Road  
Indianapolis, IN 46219  
Telephone: (317) 898-4170

**Clutches**

Advanced Drivetrain Corporation  
938 South Marr Road  
Columbus, IN 47201  
Telephone: (812) 377-8894

Twin Disc International S.A.  
Chaussee de Namur  
Nivelles  
Belguim  
Telephone: 067-224941

Twin Disc Clutch Co.  
Racine, WI 53403  
Telephone: (414) 634-1981

**Coolant Heaters**

Fleetguard, Inc.  
Route 8  
Cookeville, TN 38501  
Telephone: (615) 526-9551

**Drive Plates**

Detroit Diesel Allison  
Division of General Motors  
Corporation  
P.O. Box 894  
Indianapolis, IN 46206  
Telephone: (317) 244-1511

**Electric Starting Motors**

Butec Electric  
Cleveland Road  
Leyland  
PR5 1XB  
England  
Telephone: 0744-21663

C.A.V. Electrical Equipment  
P.O. Box 36  
Warple Way  
London  
W3 7SS  
England  
Telephone: 01-743-3111

A.C. Delco Components Group  
Civic Offices  
Central Milton Keynes  
MK9 3EL  
England  
Telephone: 0908-66001

Delco-Remy  
P.O. Box 2439  
Anderson, IN 46018  
Telephone: (317) 646-7838

Leece-Neville Corp.  
1374 E. 51st Street  
Cleveland, OH 44013  
Telephone: (216) 431-0740

**Fans**

Trufflo Ltd.  
Westwood Road  
Birmingham  
B6 7JF  
England  
Telephone: 021-557-4101

Hayes-Albion  
1999 Wildwood Avenue  
Jackson, MI 49202  
Telephone: (517) 782-9421

Engineering Cooling Systems  
201 W. Carmel Drive  
Carmel, IN 46032  
Telephone: (317) 846-3438

Brookside  
McCordsville, IN 46055  
Telephone: (317) 873-5093

Aerovent  
8777 Purdue Rd.  
Indianapolis, IN 46268  
Telephone: (317) 872-0030

Kysor  
1100 Wright Street  
Cadillac, MI 49601  
Telephone: (616) 775-4681

Schwitzer  
1125 Brookside Avenue  
P.O. Box 80-B  
Indianapolis, IN 46206  
Telephone: (317) 269-3100

### Fan Clutches

Advanced Drivetrain Corporation  
983 South Marr Road  
Columbus, IN 47201  
Telephone: (812) 377-8894

Holset Engineering Co. Ltd.  
P.O. Box 9  
Turnbridge  
Huddersfield  
England  
Telephone: 0484-22244

Horton Industries, Inc.  
P.O. Box 9455  
Minneapolis, MN 55440  
Telephone: (612) 378-6410

Rockford Power Train, Inc.  
1200 Windsor Road  
P.O. Box 2908  
Rockford, IL 61132-2908  
Telephone: (815) 633-7460

Transportation Components Group  
Facet Enterprises, Inc.  
Elmira, NY 14903  
Telephone: (607) 737-8212

### Filters

Fleetguard International Corp.  
Cavalry Hill Industrial Park  
Weedon  
Northampton NN7 4TD  
England  
Telephone: 0327-41313

Fleetguard, Inc.  
Route 8  
Cookeville, TN 38501  
Telephone: (615) 526-9551

### Flexplates

Corrugated Packing and  
Sheet Metal  
Hamsterley  
Newcastle Upon Tyne  
Telephone: 0207-560-505

Detroit Diesel Allison  
Division of General Motors  
Corporation  
P.O. Box 894  
Indianapolis, IN 46206  
Telephone: (317) 244-1511

Detroit Diesel Allison  
Division of General Motors  
36501 Van Born Road  
Romulus, MI 48174  
Telephone: (313) 595-5711

Midwest Mfg. Co.  
30161 Southfield Road  
Southfield, MI 48076  
Telephone: (313) 642-5355

### Fuel Warmers

Fleetguard, Inc.  
Route 8  
Cookeville, TN 38501  
Telephone: (615) 526-9551

### Gauges

A.I.S.  
Dyffon Industrial Estate  
Ystrad Mynach  
Hengoed  
Mid Glamorgan  
CF8 7XD  
England  
Telephone: 0443-812791

Grasslin U.K. Ltd.  
Vale Rise  
Tonbridge  
Kent  
TN9 1TB  
England  
Telephone: 0732-359888

Icknield Instruments Ltd.  
Jubilee Road  
Letchworth  
Herts  
England  
Telephone: 04626-5551

Superb Tool and Gauge Co.  
21 Princip Street  
Birmingham  
B4 61E  
England  
Telephone: 021-359-4876

Kabi Electrical and Plastics  
Cranborne Road  
Potters Bar  
Herts  
EN6 3JP  
England  
Telephone: 0707-53444

Datcon Instrument Co.  
P.O. Box 128  
East Petersburg, PA 17520  
Telephone: (717) 569-5713

Rochester Gauge of Texas  
11637 Denton Drive  
Dallas, TX 75229  
Telephone: (214) 241-2161

### Governors

Woodward Governors Ltd.  
P.O. Box 15  
663/664 Ajax Avenue  
Slough  
Bucks  
SL1 4DD  
England  
Telephone: 0753-26835

Woodward Governor Co.  
1000 E. Drake Road  
Fort Collins, CO 80522  
Telephone: (303) 482-5811

Barber Colman Co.  
1300 Rock Street  
Rockford, IL 61101  
Telephone: (815) 877-0241

United Technologies  
Diesel Systems  
1000 Jorie Blvd.  
Oak Brook, IL 60521  
Telephone: (312) 325-2020

### Hydraulic and Power Steering Pumps

Hobourn Eaton Ltd.  
Priory Road  
Strood  
Rochester  
Kent  
ME2 2BD  
Telephone: 0634-71773

Honeywell Control Systems Ltd.  
Honeywell House  
Charles Square  
Bracknell  
Berks RG12 1EB  
Telephone: 0344-424555

Sundstrand Hydratec Ltd.  
Cheney Manor Trading Estate  
Swindon  
Wiltshire  
SN2 2PZ  
England  
Telephone: 0793-30101

Sperry Vickers  
1401 Crooks Road  
Troy, MI 48084  
Telephone: (313) 280-3000

Z.F.  
P.O. Box 1340  
Grafvonsoden Strasse  
5-9 D7070  
Schwaebisch Gmuend  
West Germany  
Telephone: 7070-7171-31510

### Oil Heaters

Fleetguard, Inc.  
Route 8  
Cookeville, TN 38501  
Telephone: (615) 526-9551

Kim Hotstart Co.  
West 917 Broadway  
Spokane, WA 99210  
Telephone: (509) 534-6171

### Safety Controls

Teddington Industrial  
Equipment  
Windmill Road  
Sunburn on Thames  
Middlesex  
TW16 7HF  
England  
Telephone: 09327-85500

The Nason Company  
10388 Enterprise Drive  
Davisburg, MI 48019  
Telephone: (313) 625-5381

### Torque Converters

Twin Disc International S.A.  
Chaussee de Namur  
Nivelles  
Belgium  
Telephone: 067-224941



Twin Disc Clutch Co.  
Racine, WI 53403  
Telephone: (414) 634-1981

Rockford Division  
Borg-Warner Corporation  
1200 Windsor Road  
P.O. Box 7007  
Rockford, IL 61125-7007  
Telephone: (815) 633-7460

Modine  
1500 DeKoven Avenue  
Racine, WI 53401  
Telephone: (414) 636-1640

<b>About the Manual</b> .....	i-2	<b>Engine Testing - Test Specifications</b> .....	V-35
<b>Accessories - Installation</b> .....	0-88	<b>Fan Hub - Specifications</b> .....	V-31
<b>Accessories - Removal</b> .....	0-24	<b>Fuel System</b> .....	V-26
<b>Accessory Drive - Cleaning</b> .....	9-4	<b>Lubricating Oil System - Specifications</b> .....	V-29
<b>Accessory Drive - Inspection</b> .....	9-4	<b>Rocker Levers and Pedestals</b> .....	V-25
<b>Accessory Drive Adapter - Exploded View</b> .....	9-2	<b>Tappet and Push Rods</b> .....	V-26
<b>Accessory Drive Adaptor - Assembly</b> .....	9-5	<b>Thermostat, Coolant Operating Temperature</b> .....	V-31
<b>Accessory Drive Adaptor - Disassembly</b> .....	9-4	<b>Connecting Rod - Inspection</b> .....	1-44
<b>Additional Service Literature</b> .....	L-2	<b>Crankshaft - Cleaning</b> .....	1-26
<b>Aftercooler Assembly - Cleaning and Inspection for Reuse</b> ..	10-6	<b>Crankshaft - Inspection</b> .....	1-26
Inspection .....	10-6	<b>Crankshaft - Installation</b> .....	0-42
<b>Aftercooler Assembly - Rebuild</b> .....	10-7	<b>Crankshaft - Removal</b> .....	0-39
<b>Air Compressor - Cleaning and Inspection for Reuse</b> .....	12-3	<b>Crankshaft End Play - Measuring</b> .....	0-66
Inspection .....	12-3	<b>Crankshaft Gear - Replacement</b> .....	1-27
<b>Air Crossover Tube - Cleaning and Inspection for Reuse</b> .....	10-8	<b>Cup Plug Replacement</b> .....	2-13
Cleaning .....	10-8	<b>Cylinder Block - Cleaning</b> .....	1-12
Inspection .....	10-8	<b>Cylinder Block - De-Glazing</b> .....	1-17
<b>Air Equipment - General Information</b> .....	12-2	<b>Cylinder Block - Disassembly</b> .....	1-10
Air Compressor .....	12-2	<b>Cylinder Block - Exploded View</b> .....	1-4
<b>Air Intake System - Exploded View</b> .....	10-2	<b>Cylinder Block - General Information</b> .....	1-7
<b>Air Intake System - General Information</b> .....	10-4	Camshaft: .....	1-7
<b>Air Transfer Pipe - Cleaning and Inspection for Reuse</b> .....	10-7	Crankshaft: .....	1-7
Cleaning .....	10-7	Cylinder Block .....	1-7
Inspection .....	10-8	Oil Seals .....	1-7
<b>Alternator - Installation</b> .....	0-111	Pistons .....	1-7
<b>Alternator - Removal</b> .....	0-11	Vibration Damper .....	1-7
<b>Alternator Inspection</b> .....	13-3	<b>Cylinder Block - Inspection</b> .....	1-15
<b>Balancer - Assembly</b> .....	1-51	<b>Cylinder Block - Precheck Before Disassembly</b> .....	1-10
<b>Balancer - Disassembly</b> .....	1-48	<b>Cylinder Block - Prepare for Assembly</b> .....	0-41
<b>Balancer - Installation</b> .....	0-62	<b>Cylinder Block - Removing From the Rollover Stand</b> .....	0-41
<b>Balancer - Removal</b> .....	0-35	<b>Cylinder Block - Service Tools</b> .....	1-8
Locking the Balancer .....	0-35	<b>Cylinder Block - Storing</b> .....	1-25
Measuring Backlash .....	0-35	<b>Cylinder Block Group Inspection Checklist</b> .....	1-9
Measuring the End Play .....	0-35	<b>Cylinder Head - Assembly</b> .....	2-21
Removing the Balancer .....	0-36	<b>Cylinder Head - Cleaning</b> .....	2-7
<b>Belt Tensioner - Inspection</b> .....	8-10	<b>Cylinder Head - Disassembly</b> .....	2-6
<b>Belt Tensioner - Installation</b> .....	0-111	<b>Cylinder Head - Installation</b> .....	0-92
<b>Belt Tensioner - Removal</b> .....	0-10	<b>Cylinder Head - Precheck Before Disassembly</b> .....	2-6
<b>Belt Tensioner and Fan Hub - Exploded View</b> .....	8-5	<b>Cylinder Head - Removal</b> .....	0-22
<b>Belt Tensioner and Fan Hub - General Information</b> .....	8-6	<b>Cylinder Head - Service Tools</b> .....	2-2
Belt Tensioner .....	8-6	<b>Cylinder Head - Tightening</b> .....	0-95
<b>Blowby Measurement</b> .....	14-7	<b>Cylinder Head Combustion Face Inspection</b> .....	2-11
Blowby Conversion Chart (5.613 mm [0.221 in] Orifice) .....	14-7	<b>Cylinder Head Cracks - Reuse Guidelines</b> .....	2-12
<b>Camshaft - Cleaning</b> .....	1-29	<b>Data Plate - Replacement</b> .....	1-59
<b>Camshaft - Installation</b> .....	0-56	<b>Dipstick - Removal</b> .....	0-19
Camshaft End Play - Measuring .....	0-58	<b>Dipstick Tube - Replacement</b> .....	1-25
Camshaft Gear Backlash - Measuring .....	0-59	<b>Drive Belt - Installation</b> .....	0-113
<b>Camshaft - Removal</b> .....	0-31	<b>Drive Belt - Removal</b> .....	0-9
Measuring Gear Lash .....	0-31	<b>Drive Belt Tension</b> .....	V-36
<b>Camshaft and Gear - Inspection</b> .....	1-29	<b>Drive Units - General Information</b> .....	9-3
Camshaft Lobe Edge Deterioration (Breakdown) Criteria .....	1-31	Accessory Drive Adapter .....	9-3
Camshaft Lobe Pitting Reuse Criteria .....	1-30	<b>Electrical Equipment - General Information</b> .....	13-2
<b>Camshaft Bushing - Installation</b> .....	1-23	<b>Engine - Painting</b> .....	14-28
<b>Camshaft Capscrew - Installation</b> .....	1-38	<b>Engine Assembly</b> .....	0-41
<b>Camshaft Expansion Plug - Installation</b> .....	1-22	<b>Engine Component Torque Values</b> .....	V-3 , V-4 , V-5
<b>Camshaft Gear - Replacement</b> .....	1-34	<b>Engine Diagram - Automotive Engine</b> .....	E-9
Camshaft Gear - Installation (Heated Gear Method) .....	1-34	<b>Engine Disassembly</b> .....	0-8
Camshaft Gear - Installation (With Special Tool 3823589) .....	1-36	<b>Engine Disassembly and Assembly</b> .....	0-4
Camshaft Gear - Removal .....	1-34	Assembly .....	0-4
<b>Capscrew Markings and Torque Values</b> .....	V-41	Disassembly .....	0-4
<b>Charge Air Cooler (CAC) - Cleaning and Inspection for Reuse</b> ..	10-8	General Information .....	0-4
Cleaning .....	10-8	<b>Engine Disassembly and Assembly - Service Tools</b> .....	0-5
Inspection .....	10-9	<b>Engine Disassembly Check List</b> .....	0-7
<b>Charge Air Cooler (CAC) - Pressure Testing</b> .....	10-9	<b>Engine Dynamometer Test - Engine Run-In</b> .....	14-14
<b>Chassis Dynamometer - Operation</b> .....	14-20	<b>Engine Dynamometer Test - Performance Checking</b> .....	14-18
<b>Component Specifications and Torque Values</b> .....	V-6	<b>Engine Dynamometer Test - Installation of the Engine</b> .....	14-8
Air Intake System .....	V-32	<b>Engine Identification</b> .....	E-2
Combustion Air System .....	V-31	Automotive Engine Dataplate .....	E-2
Compressed Air System Torque Values .....	V-33	Automotive Engine Nomenclature .....	E-3
Cylinder Block - Rebuild Specifications .....	V-16	Engine Dataplate .....	E-2
Cylinder Block - Torque Values .....	V-22	Industrial Engine Nomenclature .....	E-3
Cylinder Head - Rebuild Specifications .....	V-23	<b>Engine Run-In Procedure - (Chassis Dynamometer)</b> .....	14-25
Cylinder Head - Torque Values .....	V-25	<b>Engine Run-In Procedure "In Chassis" - (On- and</b>	
Electrical System .....	V-34	Off-Highway Vehicles) .....	14-27
Engine Assembly - Capscrew Torque Values .....	V-10	Off-Highway .....	14-27
Engine Assembly - Specifications .....	V-6	On-Highway .....	14-27

Index  
Page 2

<b>Engine Storage - Long Term</b> .....	14-31	<b>General Information</b> .....	2-5
Removing the Engine from Long-Term Storage .....	14-34	Exhaust Manifold .....	11-3
<b>Engine Storage - Short Term</b> .....	14-29	Flywheel and Ring Gear .....	16-2
Removing the Engine from Short-Term Storage .....	14-31	Flywheel Housing .....	16-2
<b>Engine Testing - Engine Side Views</b> .....	14-4, 14-5	Front Support .....	16-2
<b>Engine Testing - General Information</b> .....	14-6	<b>General Information - Injectors</b> .....	6-4
General Engine Test Specifications .....	14-6	<b>General Information - Lubrication System</b> .....	7-6
<b>Engine Testing - Service Tools</b> .....	14-2	Oil Cooler Core .....	7-6
<b>Engine Weight</b> .....	0-8	<b>General Information About Fans</b> .....	8-14
<b>Exhaust Manifold - Exploded View</b> .....	11-2	<b>General Repair Instructions</b> .....	i-10
<b>Exhaust Manifold - Installation</b> .....	0-105	<b>General Safety Instructions</b> .....	i-9
<b>Exhaust Manifold - Removal</b> .....	0-14	Important Safety Notice .....	i-9
<b>Exhaust Manifold Inspection</b> .....	11-4	<b>Generic Symbols</b> .....	i-4
<b>Expansion and Pipe Plug - Installation</b> .....	1-20	<b>Glossary of Terms</b> .....	i-12
<b>Exploded View</b> .....	2-3	<b>How To Use The Manual</b> .....	i-3
<b>Exploded View - Fuel System</b> .....	5-3	Group Contents .....	i-3
<b>Fan Hub - Disassembly</b> .....	8-7	Index .....	i-3
<b>Fan Hub - Inspection</b> .....	8-7	Metric Information .....	i-3
<b>Fan Hub - Installation</b> .....	0-110	Table of Contents .....	i-3
<b>Fan Hub - Removal</b> .....	0-11	<b>Illustrations</b> .....	i-8
<b>Fan Hub Assembly</b> .....	8-8	<b>Injection Pump - General Information</b> .....	5-4
<b>Fan Pulley - Removal</b> .....	0-10	<b>Injection Pump - Identification</b> .....	5-4
<b>Filter Bypass Valve - Replace</b> .....	7-8	<b>Injection Pump - Installation</b> .....	0-71
<b>Flywheel - Installation</b> .....	0-89	Injection Pumps - Unlocking .....	0-74
<b>Flywheel - Removal</b> .....	0-23	Locked Timed Injection Pump - Installation .....	0-72
<b>Flywheel and Ring Gear Inspection</b> .....	16-3	Unlocked Bosch VE and P7100 Injection Pump - Installation ..	0-80
<b>Flywheel Housing - Installation</b> .....	0-89	Unlocked CAV Injection Pump - Installation .....	0-76
<b>Flywheel Housing - Removal</b> .....	0-23	Unlocked Stanadyne DB4 Injection Pump - Installation .....	0-77
<b>Flywheel Housing Assembly</b> .....	16-4	<b>Injection Pump - Removal (In-Line)</b> .....	0-26
Wet Clutch Application .....	16-5	<b>Injection Pump - Removal (Rotary Type Pumps)</b> .....	0-24
<b>Flywheel Housing Inspection</b> .....	16-4	Drive Gear - Removal .....	0-26
<b>Front Cover - Installation</b> .....	0-91	Gear Lash - Check .....	0-24
<b>Front Cover - Removal</b> .....	0-22	Locking the Pump .....	0-25
<b>Front Support - Cleaning and Inspection</b> .....	16-6	<b>Injection Pump Dataplate</b> .....	E-4
<b>Fuel Filter - Removal</b> .....	0-14	Lucas CAV DPA dataplate location .....	E-4
<b>Fuel Filter Head - Installation</b> .....	0-104	Robert Bosch VE dataplate location .....	E-4
<b>Fuel Filter Head - Removal</b> .....	0-15	<b>Injection Pump Repairs - Bosch VE</b> .....	5-15
<b>Fuel Lines - Clean and Inspect</b> .....	6-16	Delivery Valve Holder/Sealing Washer - Replacement .....	5-16
Fuel Drain Manifold .....	6-17	Fuel Inlet Adapter/Seal - Replacement .....	5-20
High Pressure Fuel Lines .....	6-16	Overflow Adapter/Sealing Ring - Replacement .....	5-19
Low Pressure Fuel Lines .....	6-18	Shaft Seal - Replacement .....	5-15
<b>Fuel Lines - Installation</b> .....	0-101	Shutdown Lever/Spring - Replacement .....	5-18
Fuel Drain Manifold - Installation .....	0-102	Shutdown Solenoid - Replacement .....	5-17
High Pressure Fuel Lines - Installation .....	0-103	<b>Injection Pump Repairs - Lucas CAV DPA</b> .....	5-25
Injection Pump Supply Line - Installation .....	0-101	Automatic Timing Advance - Disassembly .....	5-33
Injection Pump Vent Line - Installation .....	0-102	Back Leakage Valve - Replacement/Inspection .....	5-26
<b>Fuel Lines - Removal</b> .....	0-16	Bleed Screws/Sealing Washers - Replacement .....	5-28
Fuel Drain Manifold - Removal .....	0-17	Control Lever - Replacement .....	5-30
High Pressure Fuel Line - Removal .....	0-16	Fuel Inlet Fitting/Sealing Washer - Replacement .....	5-30
Low Pressure Fuel Lines - Removal .....	0-18	Locking Screw/O-Ring - Replacement .....	5-25
<b>Fuel Pump Stud - Replacement</b> .....	1-58	Shutdown Lever/Spring - Replacement .....	5-31
<b>Fuel Transfer Pump - Cleaning and Inspecting</b> .....	6-13	Shutdown Solenoid - Replacement .....	5-27
<b>Fuel Transfer Pump - General Information</b> .....	6-5	Timing Advance - Assembly .....	5-35
<b>Fuel Transfer Pump - Identification</b> .....	6-5	Timing Advance Components - Inspection .....	5-34
<b>Fuel Transfer Pump - Installation</b> .....	0-69	Vent Fitting/Sealing Washer - Inspection/Replacement .....	5-29
<b>Fuel Transfer Pump - Piston Style Rebuild</b> .....	6-14	<b>Injection Pump Repairs</b> .....	5-39
Assembly .....	6-15	Fuel Inlet Banjo Connector Replacement, Bosch P7100 .....	5-50
Cleaning .....	6-15	Fuel Pump Shut Off Lever Replacement, Bosch P7100 .....	5-52
<b>Fuel Transfer Pump - Removal</b> .....	0-28	Fuel Shut Off Solenoid Adjustment, Bosch P7100 .....	5-51
<b>Gear Housing - Disassembly</b> .....	1-58	Fuel Shut Off Solenoid Bracket Replacement, Bosch P7100 ..	5-52
<b>Gear Housing - Installation</b> .....	0-54	Fuel Shut Off Solenoid Replacement, Bosch P7100 .....	5-51
<b>Gear Housing - Removal</b> .....	0-34	Injection Pump Timing - Nippondenso EP9 .....	5-44
<b>Gear Housing and Timing Pin Assembly - Inspection</b> .....	1-57	Injection Pump Timing - Stanadyne DB4 .....	5-39
<b>General Cleaning Instructions</b> .....	i-11	Pressure Relief Valve and Sealing Washer Replacement,	
Glass or Plastic Bead Cleaning .....	i-11	Bosch P7100 .....	5-48
Solvent and Acid Cleaning .....	i-11	Return Connection Replacement, Stanadyne DB4 .....	5-40
Steam Cleaning .....	i-11	Seal Replacement, Bosch P7100 .....	5-50
<b>General Engine Specifications</b> .....	E-6	Seals Replacement, Nippondenso EP9 .....	5-46
Batteries (Specific Gravity) .....	E-8	Shut Down Lever or Spring Replacement, Nippondenso EP9 ..	5-46
Cooling System .....	E-7	Shutdown Solenoid Inspection, Bosch P7100 .....	5-54
Electrical System .....	E-8	Shutoff Solenoid Replacement, Stanadyne DB4 .....	5-41
Fuel System .....	E-7	Speed Droop Adjustment Off Engine - Stanadyne DB4 .....	5-43
General Engine Data .....	E-6	Throttle Lever Replacement, Bosch P7100 .....	5-53
Intake Air and Exhaust System .....	E-7	<b>Injection Pump Timing - Bosch VE</b> .....	5-21
Lubrication System .....	E-6	<b>Injector - Assembly</b> .....	6-10
<b>General Engine Test Procedures - (Chassis Dynamometer)</b> .....	14-22	<b>Injector - Clean and Inspect</b> .....	6-8

Injector - Disassembly .....	6-7	Rollover Stand - Engine Removal .....	0-113
Injector - Service Tools .....	6-2	Rubber Element Vibration Damper - Cleaning and Inspection.	1-39
Injector - Testing .....	6-12	Service Literature Order Form .....	L-4
Chatter Test .....	6-13	Service Literature Ordering Location .....	L-3
Injector Group - Exploded View .....	6-3	Service Tools - Injection Pump .....	5-2
Injector Nozzles - Installation .....	0-99	Side Oil Fill - Installation .....	0-69
Injector Nozzles - Removal .....	0-20	Side Oil Fill - Removal .....	0-29
KSB Electrical Solenoid Style - General Information .....	5-6	Simbolos Usados En Este Manual .....	i-5
Cold Start Timing Advance System (KSB) - Electrical Solenoid Style .....	5-6	Specifications - General Information .....	V-2
VE Pump Timing Advance Principles (With Electrical Solenoid KSB Installed) .....	5-8, 5-9	Starter - Installation .....	0-114
VE Pump Timing Advance Principles (Without KSB) .....	5-7	Starter - Removal .....	0-8
KSB Electrical Solenoid Style - Inspection .....	5-12	Starter Inspection .....	13-3
KSB Electrical Solenoid - Inspection .....	5-12	Steam Cleaning The Engine .....	0-8
KSB Electrical Solenoid Style Wiring Harness - Inspection .....	5-14	Suction Tube - Installation .....	0-67
KSB (Remote Mounted) - Installation .....	0-104	Suction Tube - Removal .....	0-30
KSB (Remote Mounted) - Removal .....	0-15	Symbole .....	i-6
Lifting Bracket Removal - Rear .....	0-9	Symboles Utilises Dans Ce Manuel .....	i-7
Lube Pump - Installation .....	0-55	Tap-Drill Chart - U.S. Customary & Metric .....	V-43
Lube Pump - Removal .....	0-32	Tappet Cover - Installation .....	0-70
Measuring Backlash .....	0-32	Tappet Cover - Removal .....	0-28
Lubricating Oil Cooler - Exploded View .....	7-5	Tappets and Push Rods - Exploded View .....	4-2
Lubricating Oil Pump - Exploded View .....	7-11	General Information .....	4-3
Lubrication Oil Pump - General Information .....	7-12	Tappets and Push Rods - General Information .....	4-3
Manifold Cover - Installation .....	0-100	Thermostat - Inspection .....	8-13
Aftercooler - Installation .....	0-101	Thermostat - Installation .....	0-109
Manifold Cover - Removal .....	0-19	Thermostat - Removal .....	0-12
Aftercooler - Removal .....	0-19	Thermostat Housing Assembly - Exploded View .....	8-11
Newton-Meter to Foot-Pound Conversion Chart .....	V-39	Thermostat Housing Assembly - General Information .....	8-12
Capscrew Markings and Torque Values - U.S. Customary .....	V-40	Timing Pin - Installation .....	0-59
Oil - Draining .....	0-9	Timing Pin Housing - Removal .....	0-34
Oil Cooler - Cleaning .....	7-9	Turbocharger - Cleaning and Inspection for Reuse .....	10-5
Oil Cooler - Inspection .....	7-9	Inspection .....	10-5
Oil Cooler - Installation .....	0-69	Turbocharger - Installation .....	0-106
Oil Cooler - Removal .....	0-29	Turbocharger - Removal .....	0-12
Oil Filter - Installation .....	0-113	Turbocharger Drain Tube - Removal .....	0-41
Oil Pan - Installation .....	0-68	Turbocharger Mounting Stud Replacement .....	11-4
Oil Pan Sealing Surfaces - Sealants .....	0-68	United States and United Kingdom Offices .....	C-2, C-3
Oil Pan - Removal .....	0-30	Valve - Inspection .....	2-9
Oil Pan and Suction Tube - Cleaning and Inspection .....	7-4	Valve Clearance - Adjustment .....	0-97
Oil Pan and Suction Tube - Exploded View .....	7-2	Valve Covers - Installation .....	0-100
Oil Pan and Suction Tube - General Information .....	7-3	Valve Covers - Removal .....	0-20
Oil Pump - Inspection .....	7-13	Valve Guide Inspection .....	2-11
Pipe Plug Torque Values .....	V-42	Valve Seat Inspection .....	2-11
Piston and Connecting Rod - Assembly .....	1-45	Valve Seats - Grinding .....	2-16
Piston and Connecting Rod - Disassembly .....	1-41	Calculating the Grinding Depth .....	2-16
Piston and Rod Assemblies - Installation .....	0-47	Measuring the Valve Depth .....	2-16
Piston and Connecting Rod Assemblies - Installation .....	0-50	Valve Spring Inspection .....	2-12
Piston Grading For 1994 Automotive Applications Only .....	0-47	Valve Tappets - Inspection .....	4-4
Piston and Rod Assemblies - Removal .....	0-37	Valve Tappets - Installation .....	0-42
Piston Inspection .....	1-42	Valve Tappets - Removal .....	0-32
Piston Pin - Inspection .....	1-43	Valves - Grinding .....	2-15
Piston, Pin and Connecting Rod - Cleaning .....	1-41	Vibration Damper - Installation .....	0-110
Piston Ring Gap - Checking .....	1-46	Vibration Damper/Crankshaft Pulley - Removal .....	0-10
Piston Rings - Installation .....	1-47	Water Inlet Connection - Installation .....	0-111
Pressure Regulator Valve - Assembly .....	7-8	Water Inlet Connection - Removal .....	0-29
Pressure Regulator Valve - Disassembly .....	7-7	Water Pump - Exploded View .....	8-2
Pressure Regulator Valve - Inspection .....	7-7	Water Pump - General Information .....	8-3
Push Rods - Inspection .....	4-4	Water Pump - Inspection .....	8-4
Push Rods - Installation .....	0-93	Water Pump - Installation .....	0-90
Push Rods - Removal .....	0-21	Water Pump - Removal .....	0-23
Rear Seal - Installation .....	0-66	Weight and Measures - Conversion Factors .....	V-38
Rear Seal Housing - Removal .....	0-30		
Ring Gear Replacement .....	16-3		
Rocker Lever - Inspection .....	3-6		
Rocker Lever Assembly - Exploded View .....	3-2		
Rocker Lever Assembly - General Information .....	3-4		
Rocker Lever Pedestals - Inspection .....	3-7		
Rocker Levers - Assembly .....	3-7		
Rocker Levers - Disassembly .....	3-5		
Rocker Levers - Installation .....	0-94		
Rocker Levers - Removal .....	0-21		
Rocker Levers and Pedestals - Cleaning .....	3-6		
Rod Bearing Clearance - Checking .....	1-44		
Rollover Stand - Engine Mounting .....	0-8		





NO POSTAGE  
NECESSARY  
IF MAILED  
IN THE  
UNITED STATES

**BUSINESS REPLY MAIL**

FIRST CLASS PERMIT NO. 15, COLUMBUS INDIANA

-POSTAGE WILL BE PAID BY ADDRESSEE-

CUMMINS ENGINE COMPANY, INC.  
MAIL CODE 20803  
BOX 3005  
COLUMBUS, IN 47202-9982

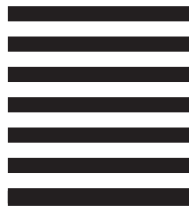

# Literature Survey Form

Bulletin No. 3666017-01 by Dept. \_\_\_\_\_

We are always open to any suggestions or recommendations that will aid in improving our manuals. Use this postage paid survey form to evaluate this manual. Please check the appropriate response and use the space provided below to list any additional comments:

	Yes	No
Is the needed information easy to locate in the manual?	_____	_____
Is the information easy to read?	_____	_____
Is the information easy to understand?	_____	_____
Does the information sufficiently cover the subject?	_____	_____
Are subjects in the Index specific enough to locate in the manual?	_____	_____
Are the important points sufficiently emphasized?	_____	_____
Are the illustrations easy to understand?	_____	_____
Does the text support the operation being illustrated?	_____	_____
Do you use the Table of Contents?	_____	_____
Do you use the Index?	_____	_____

What feature(s) of the manual do you like? \_\_\_\_\_

\_\_\_\_\_

What feature(s) of the manual don't you like? \_\_\_\_\_

\_\_\_\_\_

What additional information should the manual include? \_\_\_\_\_

\_\_\_\_\_

Please comment on any response(s) marked "No" in this survey. \_\_\_\_\_

\_\_\_\_\_

\_\_\_\_\_

Other comments that you feel would help improve the manual? \_\_\_\_\_

\_\_\_\_\_

\_\_\_\_\_

Please fold and staple

**Cummins Engine Company, Inc.**  
Box 3005  
Columbus, Indiana, U.S.A., 47202  
Cable: CUMDIEX COLUMBUS

Registered Office  
**Cummins Engine Company, Ltd.**  
46-50 Coombe Road  
New Malden,  
Surrey KT3 4QL,  
England  
Cable: CUMEUR G  
Registration No. 573951 England

Copyright© 1994  
Cummins Engine Company, Inc.



### **Section III. Vendor Troubleshooting Manual.**

Section III contains information for troubleshooting the engine in the form of the manufacturer's technical manual which follows this page. Section I contains U.S. Army supplemental information to the vendor manuals. Section II contains information for servicing the engine in the form of the manufacturer's technical manual.





# Troubleshooting and Repair Manual B3.9 and B5.9 Series Engines

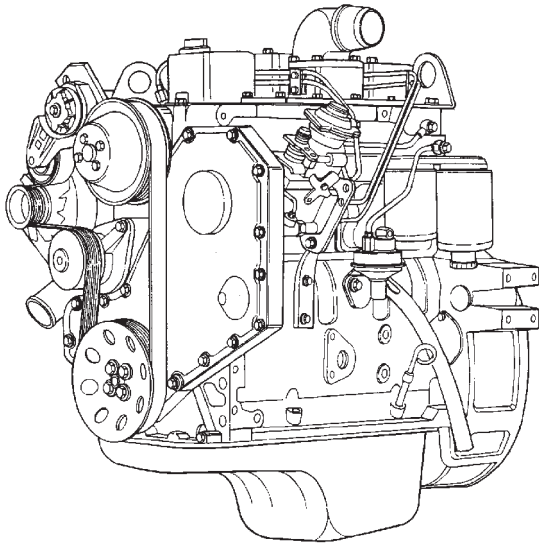

**B3.9**

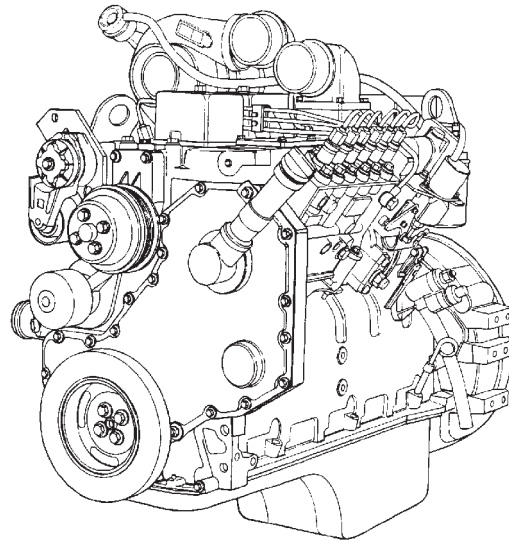

**B5.9**

00900131

## Foreword

This manual provides instructions for troubleshooting and repairing this engine in the chassis. Component and assembly rebuild procedures are provided in the engine shop manual. Refer to Section i - Introduction for instructions on how to use this manual.

**Read and follow all safety instructions. Refer to the WARNING in the General Safety Instructions in Section i - Introduction.**

The manual is organized to guide a service technician through the logical steps of identifying and correcting problems related to the engine. This manual does not cover vehicle or equipment problems. Consult the vehicle or equipment manufacturer for repair procedures.

A series of specific service manuals (for example: Shop, Specifications, and Alternative Repair) are available and can be ordered by filling out and mailing the Literature Order Form located in Section L - Service Literature.

The repair procedures used in this manual are recommended by Cummins Engine Co., Inc. Some service procedures require the use of special service tools. Use the correct tools as described.

Cummins Engine Company, Inc. encourages the user of this manual to report errors, omissions, and recommendations for improvement. Please use the postage paid, pre-addressed Literature Survey Form in the back of this manual for communicating your comments.

The specifications and rebuild information in this manual are based on the information in effect at the time of printing. Cummins Engine Company, Inc. reserves the right to make any changes at any time without obligation. If differences are found between your engine and the information in this manual, contact a Cummins Authorized Repair Location or call 1-800-DIESELS (1-800-343-7357) toll free in the U.S. and Canada.

The latest technology and the highest quality components are used to manufacture Cummins engines. When replacement parts are needed, we recommend using only genuine Cummins or ReCon® exchange parts. These parts can be identified by the following trademarks:



Table of Contents

	Section
Introduction .....	i
Engine Identification .....	E
Troubleshooting Symptoms .....	TS
Complete Engine - Group 00 .....	0
Cylinder Block - Group 01 .....	1
Cylinder Head - Group 02 .....	2
Rocker Levers - Group 03 .....	3
Cam Followers/Tappets - Group 04 .....	4
Fuel Systems - Group 05 .....	5
Injectors and Fuel Lines - Group 06 .....	6
Lubricating System - Group 07 .....	7
Cooling System - Group 08 .....	8
Drive Units - Group 09 .....	9
Air Intake System - Group 10 .....	10
Exhaust System - Group 11 .....	11
Compressed Air System - Group 12 .....	12
Electrical Equipment - Group 13 .....	13
Engine Testing - Group 14 .....	14
Mounting Adaptations - Group 16 .....	16
Miscellaneous - Group 17 .....	17
Specifications .....	V
Component Manufacturers .....	M
Service Literature .....	L
Index .....	X



# Section i - Introduction

## Section Contents

	Page
<b>About the Manual</b> .....	i-1
<b>Acronyms and Abbreviations</b> .....	i-4
<b>General Cleaning Instructions</b> .....	i-7
Glass or Plastic Bead Cleaning .....	i-7
Solvent and Acid Cleaning .....	i-7
Steam Cleaning .....	i-7
<b>General Repair Instructions</b> .....	i-6
<b>General Safety Instructions</b> .....	i-5
Important Safety Notice .....	i-5
<b>How to Use the Manual</b> .....	i-1
<b>Illustrations</b> .....	i-3
<b>Symbols</b> .....	i-2

**THIS PAGE LEFT INTENTIONALLY BLANK**



## About the Manual

This B3.9 and B5.9 Series Engines Troubleshooting and Repair Manual is intended to aid in determining the cause of engine-related problems and to provide recommended repair procedures. The manual is divided into sections by system. Each section provides general information, specifications, diagrams, and service tools, where applicable. The specific repair procedures are referenced in the Troubleshooting Symptom Charts.

## How to Use the Manual

This manual is organized to provide an easy flow from problem identification to problem correction. A list of troubleshooting symptoms containing the most common engine problems is in the Troubleshooting Symptoms, Section TS. This manual is designed to use the Troubleshooting Symptoms as a guide in locating the problem and directing the end user to the correct procedure for making the necessary repairs to the engine. Complete the following steps to locate and correct any problems:

1. Locate the symptom on the Section Contents page of Section TS.
2. Reference to the page number where the Troubleshooting Symptom Tree is found is made to the right of the symptom tree title.
3. The left column of boxes in the Troubleshooting Symptom Charts indicates a probable cause of the problem, starting at the top with the simplest and easiest to repair, and continuing downward to the most difficult.
4. The right column of boxes provides a brief description of the corrective action with a reference number to the correct procedure used to make the repair.
5. Locate the probable cause in the left column; then turn to the procedure referenced in the right column.

The Troubleshooting Symptom Charts are based on the following assumptions:

- The engine has been installed according to the OEM's specifications.
- The easiest repairs are done first.
- "Generic" solutions are provided for most common OEM applications.

Refer to Section V for specifications recommended by Cummins Engine Company, Inc. for the engine. Specifications and torque values for each engine system are given in Section V.

## Symbols

The following symbols have been used in this manual to help communicate the intent of the instructions. When one of the symbols appears, it conveys the meaning defined below:



**WARNING** - Serious personal injury or extensive property damage can result if the warning instructions are **not** followed.



**CAUTION** - Minor personal injury can result or a part, an assembly, or the engine can be damaged if the caution instructions are **not** followed.



Indicates a **REMOVAL** or **DISASSEMBLY** step.



Indicates an **INSTALLATION** or **ASSEMBLY** step.



**INSPECTION** is required.



**CLEAN** the part or assembly.



**PERFORM** a mechanical or time **MEASUREMENT**.



**LUBRICATE** the part or assembly.



Indicates that a **WRENCH** or **TOOL SIZE** will be given.



**TIGHTEN** to a specific torque.



**PERFORM** an electrical **MEASUREMENT**.



Refer to another location in this manual or another publication for additional information.



The component weighs 23 kg [50 lb] or more. To avoid personal injury, use a hoist or get assistance to lift the component.

17800006

### Illustrations

Some of the illustrations throughout this manual are generic and will **not** look exactly like the engine or parts used in your application. The illustrations can contain symbols to indicate an action required and an acceptable or **not** acceptable condition.

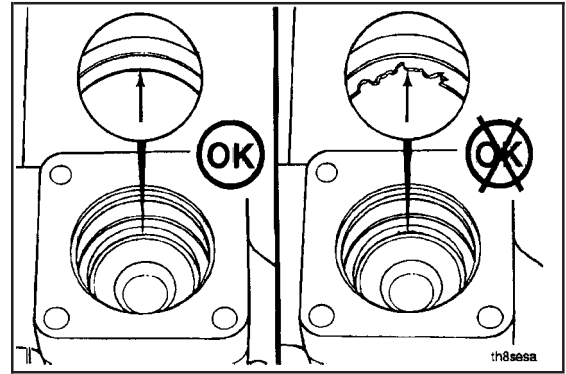

The illustrations are intended to show repair or replacement procedures. The procedure will be the same for all applications, although the illustration can differ.

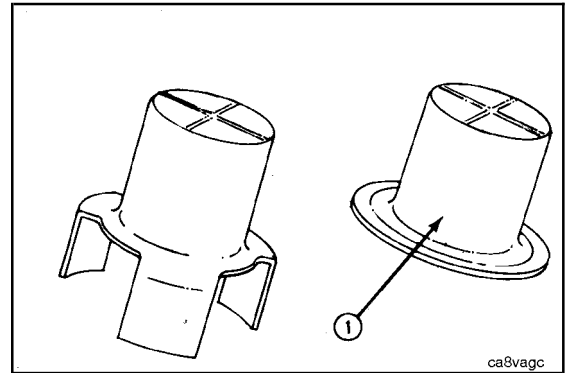

**Acronyms and Abbreviations**

<b>AFC</b>	Air Fuel Control	<b>kPa</b>	Kilopascal
<b>API</b>	American Petroleum Institute	<b>LNG</b>	Liquid Natural Gas
<b>ASA</b>	Air Signal Attenuator	<b>LTA</b>	Low Temperature Aftercooling
<b>ASTM</b>	American Society of Testing and Materials	<b>MIP</b>	Mixer Inlet Pressure
<b>°C</b>	Celsius	<b>MPa</b>	Megapascal
<b>CARB</b>	California Air Resources Board	<b>mph</b>	Miles Per Hour
<b>C.I.D.</b>	Cubic Inch Displacement	<b>mpq</b>	Miles Per Quart
<b>CNG</b>	Compressed Natural Gas	<b>N•m</b>	Newton-meter
<b>CPL</b>	Control Parts List	<b>NG</b>	Natural Gas
<b>cSt</b>	Centistokes	<b>OEM</b>	Original Equipment Manufacturer
<b>ECM</b>	Electronic Control Module	<b>ppm</b>	Parts Per Million
<b>ECS</b>	Emission Control System	<b>psi</b>	Pounds Per Square Inch
<b>EPA</b>	Environmental Protection Agency	<b>PTO</b>	Power Takeoff
<b>EPS</b>	Engine Position Sensor	<b>rpm</b>	Revolutions Per Minute
<b>°F</b>	Fahrenheit	<b>SAE</b>	Society of Automotive Engineers
<b>GVW</b>	Gross Vehicle Weight	<b>SCA</b>	Supplemental Coolant Additive
<b>Hg</b>	Mercury	<b>STC</b>	Step Timing Control
<b>hp</b>	Horsepower	<b>VS</b>	Variable Speed
<b>H<sub>2</sub>O</b>	Water	<b>VSS</b>	Vehicle Speed Sensor
<b>ICM</b>	Ignition Control Module		
<b>km/l</b>	Kilometers per Liter		

## General Safety Instructions

### Important Safety Notice



**Improper practices or carelessness can cause burns, cuts, mutilation, asphyxiation or other bodily injury or death.**

Read and understand all of the safety precautions and warnings before performing any repair. This list contains the general safety precautions that **must** be followed to provide personal safety. Special safety precautions are included in the procedures when they apply.

- Make sure the work area surrounding the product is dry, well lit, ventilated, free from clutter, loose tools, parts, ignition sources and hazardous substances. Be aware of hazardous conditions that can exist.
- **Always** wear protective glasses and protective shoes when working.
- Rotating parts can cause cuts, mutilation or strangulation.
- Do **not** wear loose-fitting or torn clothing. Remove all jewelry when working.
- Disconnect the battery (negative [-] cable first) and discharge any capacitors before beginning any repair work. Disconnect the air starting motor if equipped to prevent accidental engine starting. Put a “Do **Not** Operate” tag in the operator’s compartment or on the controls.
- Use **ONLY** the proper engine barring techniques for manually rotating the engine. Do **not** attempt to rotate the crankshaft by pulling or prying on the fan. This practice can cause serious personal injury, property damage, or damage to the fan blade(s) causing premature fan failure.
- If an engine has been operating and the coolant is hot, allow the engine to cool before you slowly loosen the filler cap and relieve the pressure from the cooling system.
- Do **not** work on anything that is supported **ONLY** by lifting jacks or a hoist. **Always** use blocks or proper stands to support the product before performing any service work.
- Relieve all pressure in the air, oil, fuel and the cooling systems before any lines, fittings, or related items are removed or disconnected. Be alert for possible pressure when disconnecting any device from a system that utilizes pressure. Do **not** check for pressure leaks with your hand. High pressure oil or fuel can cause personal injury.
- To prevent suffocation and frostbite, wear protective clothing and **ONLY** disconnect fuel and liquid refrigerant (freon) lines in a well ventilated area. To protect the environment, liquid refrigerant systems **must** be properly emptied and filled using equipment that prevents the release of refrigerant gas (fluorocarbons) into the atmosphere. Federal law requires capturing and recycling refrigerant.
- To avoid personal injury, use a hoist or get assistance when lifting components that weigh 23 kg [50 lb] or more. Make sure all lifting devices such as chains, hooks, or slings are in good condition and are of the correct capacity. Make sure hooks are positioned correctly. **Always** use a spreader bar when necessary. The lifting hooks **must not** be side-loaded.
- Corrosion inhibitor, a component of SCA and lubricating oil, contains alkali. Do **not** get the substance in your eyes. Avoid prolonged or repeated contact with skin. Do **not** swallow internally. In case of contact, immediately wash skin with soap and water. In case of contact, immediately flood eyes with large amounts of water for a minimum of 15 minutes. IMMEDIATELY CALL A PHYSICIAN. KEEP OUT OF REACH OF CHILDREN.
- Naptha and Methyl Ethyl Ketone (MEK) are flammable materials and **must** be used with caution. Follow the manufacturer’s instructions to provide complete safety when using these materials. KEEP OUT OF REACH OF CHILDREN.
- To avoid burns, be alert for hot parts on products that have just been turned off, and hot fluids in lines, tubes, and compartments.
- **Always** use tools that are in good condition. Make sure you understand how to use them before performing any service work. Use **ONLY** genuine Cummins or Cummins ReCon® replacement parts.
- **Always** use the same fastener part number (or equivalent) when replacing fasteners. Do **not** use a fastener of lesser quality if replacements are necessary.
- Do **not** perform any repair when fatigued or after consuming alcohol or drugs that can impair your functioning.
- Some state and federal agencies in the United States of America have determined that used engine oil can be carcinogenic and can cause reproductive toxicity. Avoid inhalation of vapors, ingestion, and prolonged contact with used engine oil.
- Coolant is toxic. If **not** reused, dispose of in accordance with local environmental regulations.

## General Repair Instructions

This engine incorporates the latest technology at the time it was manufactured; yet, it is designed to be repaired using normal repair practices performed to quality standards.

- **Cummins Engine Company, Inc. does not recommend or authorize any modifications or repairs to engines or components except for those detailed in Cummins Service Information. In particular, unauthorized repair to safety-related components can cause personal injury or death. Below is a partial listing of components classified as safety-related:**

Air Compressor  
Air Controls  
Air Shutoff Assemblies  
Balance Weights  
Cooling Fan  
Fan Hub Assembly  
Fan Mounting Bracket(s)  
Fan Mounting Capscrews  
Fan Hub Spindle  
Flywheel  
Flywheel Crankshaft Adapter

Flywheel Mounting Capscrews  
Fuel Shutoff Assemblies  
Fuel Supply Tubes  
Lifting Brackets  
Throttle Controls  
Turbocharger Compressor Casing  
Turbocharger Oil Drain Line(s)  
Turbocharger Oil Supply Line(s)  
Turbocharger Turbine Casing  
Vibration Damper Mounting Capscrews

- **Follow all safety instructions noted in the procedures**
  - Follow the manufacturer's recommendations for cleaning solvents and other substances used during the repair of the engine. Some solvents and used engine oil have been identified by government agencies as toxic or carcinogenic. Avoid excessive breathing, ingestion and contact with such substances. **Always** use good safety practices with tools and equipment.
- **Provide a clean environment and follow the cleaning instructions specified in the procedures**
  - The engine and its components **must** be kept clean during any repair. Contamination of the engine or components will cause premature wear.
- **Perform the inspections specified in the procedures**
- **Replace all components or assemblies which are damaged or worn beyond the specifications**
- **Use genuine Cummins new or ReCon® service parts and assemblies**
  - The assembly instructions have been written to use again as many components and assemblies as possible. When it is necessary to replace a component or assembly, the procedure is based on the use of new Cummins or Cummins ReCon® components. All of the repair services described in this manual are available from all Cummins Distributors and most Dealer locations.
- **Follow the specified disassembly and assembly procedures to avoid damage to the components**

Complete rebuild instructions are available in the shop manual which can be ordered or purchased from a Cummins Authorized Repair Location. Refer to Section L — Service Literature for ordering instructions.

## General Cleaning Instructions

### Solvent and Acid Cleaning

Several solvent and acid-type cleaners can be used to clean the engine parts. Experience has shown that the best results can be obtained using a cleaner that can be heated to 90 to 95 degrees Celsius [180 to 200 degrees Fahrenheit]. A cleaning tank that provides a constant mixing and filtering of the cleaning solution will give the best results. **Cummins Engine Company, Inc. does not recommend any specific cleaners. Always** follow the cleaner manufacturer's instructions.

Remove all the gasket material, o-rings, and the deposits of sludge, carbon, etc., with a wire brush or scraper before putting the parts in a cleaning tank. Be careful **not** to damage any gasket surfaces. When possible, steam clean the parts before putting them in the cleaning tank.

#### **WARNING**

**Acid is extremely dangerous and can cause personal injury and damage the machinery. Always provide a tank of strong soda water as a neutralizing agent.**

Rinse all of the parts in hot water after cleaning. Dry completely with compressed air. Blow the rinse water from all of the capscrew holes and the oil drillings.

If the parts are **not** to be used immediately after cleaning, dip them in a suitable rustproofing compound. The rustproofing compound **must** be removed from the parts before installation on the engine.

### Steam Cleaning

Steam cleaning can be used to remove all types of dirt that can contaminate the cleaning tank. It is a good way to clean the oil drillings.

#### **WARNING**

**Wear protective clothing to prevent personal injury from the high pressure and extreme heat.**

Do **not** steam clean the following parts:

- |                          |                    |
|--------------------------|--------------------|
| 1. Electrical Components | 4. Fuel Pump       |
| 2. Wiring                | 5. Belts and Hoses |
| 3. Injectors             | 6. Bearings        |

### Glass or Plastic Bead Cleaning

Glass or plastic bead cleaning can be used on many engine components to remove carbon deposits. The cleaning process is controlled by the size of the glass or plastic beads, the operating pressure, and the cleaning time.

#### **CAUTION**

**Do not use glass or plastic bead cleaning on aluminum piston skirts. Do not use glass bead cleaning on aluminum ring grooves. Small particles of glass or plastic will embed in the aluminum and result in premature wear. Valves, turbocharger shafts, etc., can also be damaged. Follow the cleaning directions listed in the procedures.**

**NOTE:** Plastic bead blasting media, Part No. 3822735, can be used to clean aluminum ring grooves. Do **not** use any bead blasting media on pin bores or aluminum skirts.

Follow the equipment manufacturer's cleaning instructions. The following guidelines can be used to adapt to manufacturer's instructions:

1. Bead size:
  - a. Use U.S. size No. 16-20 for piston cleaning with plastic bead media, Part No. 3822735.
  - b. Use U.S. size No. 70 for piston domes with glass media.
  - c. Use U.S. size No. 60 for general purpose cleaning with glass media.
2. Operating Pressure:
  - a. Glass: Use 620 kPa [90 psi] for general purpose cleaning.
  - b. Plastic: Use 270 kPa [40 psi] for piston cleaning.
3. Steam clean or wash the parts with solvent to remove all of the foreign material and glass or plastic beads after cleaning. Rinse with hot water. Dry with compressed air.
4. Do **not** contaminate the wash tanks with glass or plastic beads.





# Section E - Engine Identification

## Section Contents

	<b>Page</b>
<b>Engine Diagrams</b> .....	E-27
Engine Views .....	E-27
<b>Engine Identification</b> .....	E-1
Cummins Engine Nomenclature .....	E-2
Engine Dataplate .....	E-1
Fuel Injection Pump Dataplate .....	E-3
General Information .....	E-1
<b>Specifications</b> .....	E-4
Air Intake System .....	E-12
Batteries (Specific Gravity) .....	E-25
Compressed Air System .....	E-21
Cooling System .....	E-10
Electrical System .....	E-23
Engine Testing .....	E-25
Exhaust System .....	E-19
Fuel System .....	E-6
General Specifications .....	E-4
Lubricating Oil System .....	E-8

**THIS PAGE LEFT INTENTIONALLY BLANK**

# Engine Identification

## General Information

This section contains the specifications for the four-cylinder and six-cylinder B Series engines. The engine views show important components on the engine.

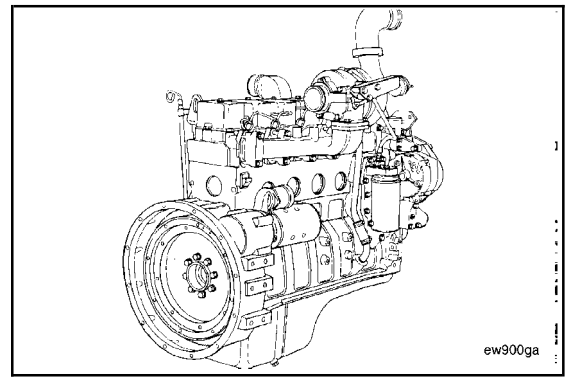

## Engine Dataplate

The engine dataplate shows specific information about the engine. The engine serial number (ESN) and control parts list (CPL) provide information for ordering parts and for service needs. The engine dataplate **must not** be changed unless approved by Cummins Engine Company, Inc.

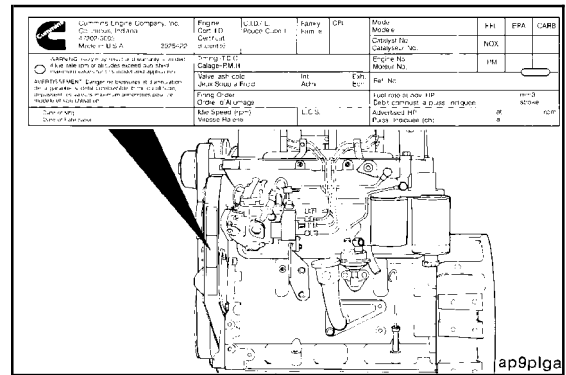

Have the following engine data available when communicating with a Cummins Authorized Repair Facility. The information on the dataplate is **mandatory** when sourcing service parts.

1. Engine Serial Number (ESN)
2. Control Parts List (CPL)
3. Model
4. Horsepower and rpm rating

Cummins Engine Company, Inc. Columbus, Indiana 47262-3005 Made in U.S.A.	Engine Cert. I.D. Certificat d'identité 3925422	C.I.D./L Pouce Cube/L	Family Famille	CPL	Model Modèle	FEL	EPA	CARB
						Catalyst No. Catalyseur No.	NOX	
WARNING Injury may result and warranty is voided if fuel rate rpm or altitudes exceed published maximum values for this model and application. AVERTISSEMENT: Danger de blessures et d'annulation de la garantie, si débit combustible, il/min ou altitude, dépassent les valeurs maximum annoncées pour ce modèle et son utilisation.	Timing-T.D.C. Calage-PM.H.	Valve lash cold Jeux Soup à Froid	Int. Adm.	Exh. Ech.	Engine No. Moteur No.	PM		
					Ref. No.			
Date of Mfg Date of Fabrication	Idle Speed (rpm) Vitesse Ralenti	E.C.S.	Fuel rate at adv. HP Débit combust. à puis. indiquée		mm <sup>3</sup> stroke		Advertised HP Puis. Indiquée (ch)	
			at a		rpm			

ap9plgb

**Cummins Engine Nomenclature**

The model name for engines in automotive applications provides the data shown below. For example:

**B (1) 3.9 (2) -105 (3)**

1. Engine series
2. Displacement in liters
3. Rated horsepower.

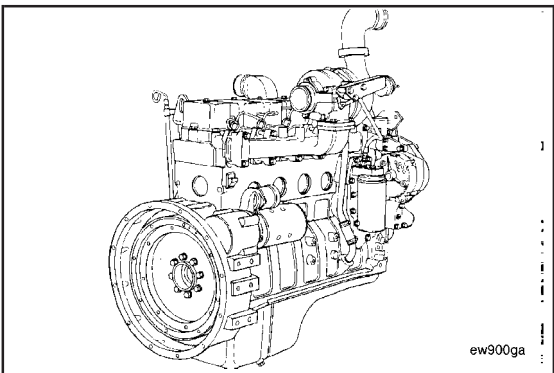

The model name for engines in nonautomotive applications provides the data shown below. For example:

**4 (1) B (2) T (3) A (4) 3.9 (5)**

1. Number of cylinders
2. Engine series
3. Turbocharged
4. Aftercooled
5. Displacement in liters.

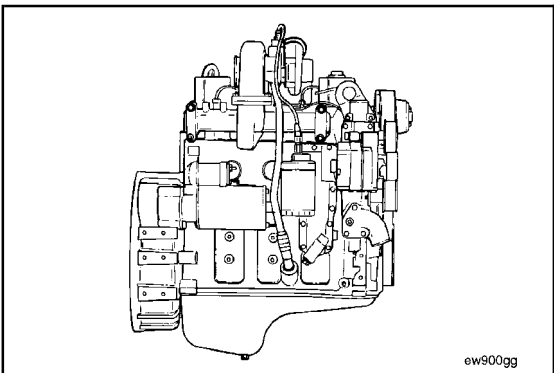

**Fuel Injection Pump Dataplate**

The fuel pump dataplate is located on the side of the fuel pump. It provides information for fuel pump calibration. This illustration shows the dataplate location on a Bosch® rotary injection pump.

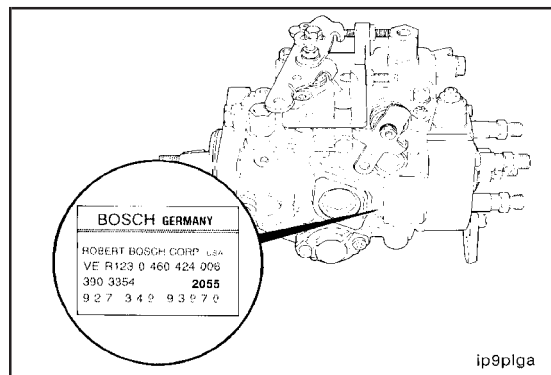

ip9plga

This illustration shows the dataplate location on a Lucas CAV rotary injection pump.

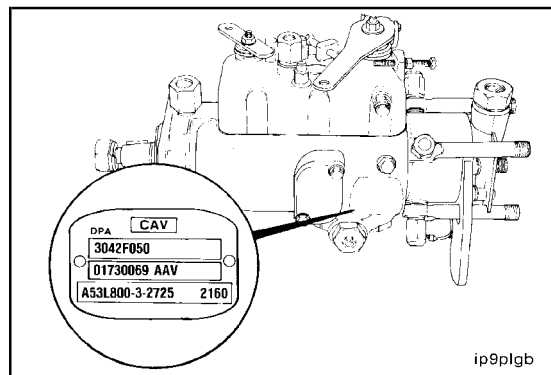

ip9plgb

This illustration shows the dataplate location on a Bosch® in-line injection pump. The Nippondenso EP-9 dataplate is in approximately the same location as the illustrated Bosch® dataplate.

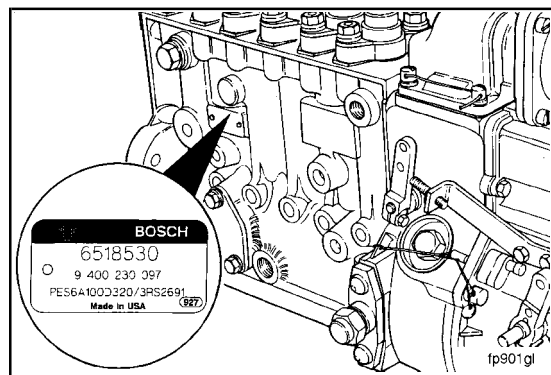

fp901gl

The Cummins part number for the in-line pump and governor combination is located on the governor dataplate.

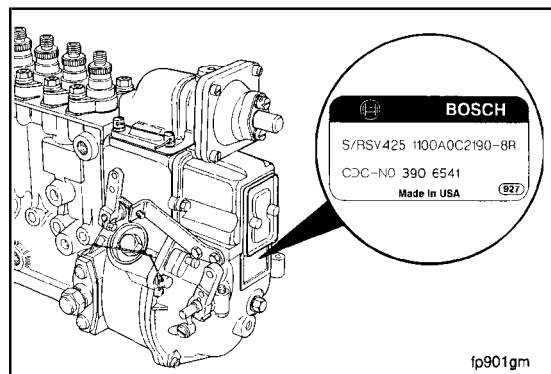

fp901gm

## Specifications

### General Specifications

#### General Engine Data (automotive)

	<b>B3.9</b>	<b>B5.9</b>
Bore	102 mm [4.02 in]	102 mm [4.02 in]
Stroke	120 mm [4.72 in]	120 mm [4.72 in]
Displacement	3.9 liters [238 in <sup>3</sup> ]	5.9 liters [360 in <sup>3</sup> ]
Engine Weight (dry) Less Flywheel and Electric Components	308 to 329 kg [679 to 725 lb]	388 to 411 kg [855 to 906 lb]
Firing Order	1, 3, 4, 2	1, 5, 3, 6, 2, 4
Valve Clearances:		
-Intake	0.25 mm [0.010 in]	0.25 mm [0.010 in]
-Exhaust	0.51 mm [0.020 in]	0.51 mm [0.020 in]
Compression Ratio	(Rotary Pump) 17.6:1	(In-Line Pump) 17.9:1
Rotation, Viewed from the Front of the Engine	<b>Clockwise</b>	<b>Clockwise</b>
Aspiration:		
- Turbocharged	X	X
- Charge-Air Cooled	X	X

General 4B Engine Data (nonautomotive)

	4B3.9	4BT3.9	4BTA3.9
Bore	102 mm [4.02 in]	102 mm [4.02 in]	102 mm [4.02 in]
Stroke	120 mm [4.72 in]	120 mm [4.72 in]	120 mm [4.72 in]
Displacement	3.9 liters [238 in <sup>3</sup> ]	3.9 liters [238 in <sup>3</sup> ]	3.9 liters [238 in <sup>3</sup> ]
Engine Weight (dry) Less Flywheel and Electric Components	308 kg [679 lb]	320 kg [705 lb]	329 kg [725 lb]
Firing Order	1, 3, 4, 2	1, 3, 4, 2	1, 3, 4, 2
Valve Clearances:			
- Intake	0.25 mm [0.010 in]	0.25 mm [0.010 in]	0.25 mm [0.010 in]
- Exhaust	0.51 mm [0.020 in]	0.51 mm [0.020 in]	0.51 mm [0.020 in]
Compression Ratio	18.5:1	17.5:1	16.5:1
Rotation, Viewed from the Front of the Engine	<b>Clockwise</b>	<b>Clockwise</b>	<b>Clockwise</b>
Aspiration:			
- Naturally Aspirated	X		
- Turbocharged		X	X
- Aftercooled			X

General 6B Engine Data (nonautomotive)

	6B5.9	6BT5.9	6BTA5.9
Bore	102 mm [4.02 in]	102 mm [4.02 in]	102 mm [4.02 in]
Stroke	120 mm [4.72 in]	120 mm [4.72 in]	120 mm [4.72 in]
Displacement	5.88 liters [359 in <sup>3</sup> ]	5.88 liters [359 in <sup>3</sup> ]	5.88 liters [359 in <sup>3</sup> ]
Engine Weight (dry) Less Flywheel and Electric Components	388 kg [855 lb]	399 kg [880 lb]	411 kg [906 lb]
Firing Order	1, 5, 3, 6, 2, 4	1, 5, 3, 6, 2, 4	1, 5, 3, 6, 2, 4
Valve Clearances:			
- Intake	0.25 mm [0.010 in]	0.25 mm [0.010 in]	0.25 mm [0.010 in]
- Exhaust	0.51 mm [0.020 in]	0.51 mm [0.020 in]	0.51 mm [0.020 in]
Compression Ratio	18.5:1	17.5:1	16.5:1
Rotation, Viewed from the Front of the Engine	<b>Clockwise</b>	<b>Clockwise</b>	<b>Clockwise</b>
Aspiration:			
- Naturally Aspirated	X		
- Turbocharged		X	X
- Aftercooled			X

**Fuel System**

**Fuel System Data (automotive)**

<b>Distributor-Type Fuel Injection Pumps</b>	<b>B3.9</b>	<b>B5.9</b>
Maximum Inlet Restriction to the Fuel Transfer Pump <b>Must Not</b> Exceed	100 mm Hg [4 in Hg]	100 mm Hg [4 in Hg]
Maximum Allowable Return Line Restriction	518 mm Hg [20.4 in Hg]	518 mm Hg [20.4 in Hg]
Maximum Allowable Pressure Drop across Fuel Filter	35 kPa [5 psi]	35 kPa [5 psi]
Maximum Inlet Pressure to the Injection Pump <b>Must Not</b> Exceed	70 kPa [10 psi]	70 kPa [10 psi]

<b>In-Line-Type Fuel Injection Pumps</b>	<b>B3.9</b>	<b>B5.9</b>
Maximum Inlet Restriction to the Fuel Transfer Pump <b>Must Not</b> Exceed	100 mm Hg [4 in Hg]	100 mm Hg [4 in Hg]
Fuel Transfer Pump Minimum Output Pressure	175 kPa [25 psi] @ Rated rpm	175 kPa [25 psi] @ Rated rpm
Fuel Filter Restriction (maximum pressure drop across filters)	35 kPa [5 psi]	35 kPa [5 psi]
Fuel Pressure Gallery Pressure	140 kPa [20 psi] @ Rated rpm	140 kPa [20 psi] @ Rated rpm
Fuel Return Maximum Restriction	518 mm Hg [20.4 in Hg]	518 mm Hg [20.4 in Hg]



4B Fuel System Data (nonautomotive)

Distributor-Type Fuel Injection Pumps	4B3.9	4BT3.9	4BTA3.9
Maximum Allowable Restriction to the Fuel Transfer Pump <b>Must Not Exceed</b>	100 mm Hg [4 in Hg]	100 mm Hg [4 in Hg]	100 mm Hg [4 in Hg]
Maximum Allowable Return Line Restriction	518 mm Hg [20.4 in Hg]	518 mm Hg [20.4 in Hg]	518 mm Hg [20.4 in Hg]
Maximum Allowable Pressure Drop across Fuel Filter	35 kPa [5 psi]	35 kPa [5 psi]	35 kPa [5 psi]
Maximum Inlet Pressure to the Injection Pump <b>Must Not Exceed</b>	70 kPa [10 psi]	70 kPa [10 psi]	70 kPa [10 psi]
<b>In-Line-Type Fuel Injection Pumps</b>			
Maximum Inlet Restriction to the Fuel Transfer Pump <b>Must Not Exceed</b>	100 mm Hg [4 in Hg]	100 mm Hg [4 in Hg]	100 mm Hg [4 in Hg]
Fuel Transfer Pump Minimum Output Pressure	172 kPa [25 psi] High Flow and 90 kPa [13 psi] Low Flow @ Rated rpm	172 kPa [25 psi] High Flow and 90 kPa [13 psi] Low Flow @ Rated rpm	172 kPa [25 psi] High Flow and 90 kPa [13 psi] Low Flow @ Rated rpm
Fuel Filter Restriction (maximum pressure drop across filters)	35 kPa [5 psi]	35 kPa [5 psi]	35 kPa [5 psi]
Fuel Pump Gallery Pressure	* 140 kPa [20 psi] @ Rated rpm	* 140 kPa [20 psi] @ Rated rpm	* 140 kPa [20 psi] @ Rated rpm
Fuel Return Maximum Restriction	518 mm Hg [20.4 in Hg]	518 mm Hg [20.4 in Hg]	518 mm Hg [20.4 in Hg]
* The low-flow fuel transfer pump will have 82.7 kPa [12 psi].			

6B Fuel System Data (nonautomotive)

Distributor-Type of Fuel Injection Pumps	6B5.9	6BT5.9	6BTA5.9
Maximum Allowable Restriction to the Fuel Transfer Pump <b>Must Not Exceed</b>	100 mm Hg [4 in Hg]	100 mm Hg [4 in Hg]	100 mm Hg [4 in Hg]
Maximum Allowable Return Line Restriction	518 mm Hg [20.4 in Hg]	518 mm Hg [20.4 in Hg]	518 mm Hg [20.4 in Hg]
Maximum Allowable Pressure Drop across Fuel Filter	35 kPa [5 psi]	35 kPa [5 psi]	35 kPa [5 psi]
Maximum Inlet Pressure to the Injection Pump <b>Must Not Exceed</b>	70 kPa [10 psi]	70 kPa [10 psi]	70 kPa [10 psi]
<b>In-Line-Type Fuel of Injection Pumps</b>			
Maximum Inlet Restriction to the Fuel Transfer Pump <b>Must Not Exceed</b>	100 mm Hg [4 in Hg]	100 mm Hg [4 in Hg]	100 mm Hg [4 in Hg]
Fuel Transfer Pump Minimum Output Pressure	172 kPa [25 psi] High Flow and 90 kPa [13 psi] Low Flow @ Rated rpm	172 kPa [25 psi] High Flow and 90 kPa [13 psi] Low Flow @ Rated rpm	172 kPa [25 psi] High Flow and 90 kPa [13 psi] Low Flow @ Rated rpm
Fuel Filter Restriction (maximum pressure drop across filters)	35 kPa [5 psi]	35 kPa [5 psi]	35 kPa [5 psi]
Fuel Pump Gallery Pressure	* 140 kPa [20 psi] @ Rated rpm	* 140 kPa [20 psi] @ Rated rpm	* 140 kPa [20 psi] @ Rated rpm
Fuel Return Maximum Restriction	518 mm Hg [20.4 in Hg]	518 mm Hg [20.4 in Hg]	518 mm Hg [20.4 in Hg]
* The low-flow fuel transfer pump will have 82.7 kPa [12 psi].			

**Lubricating Oil System**

**Lubrication System Data (automotive)**

	B3.9	B5.9
Lubricating Oil Pressure at Idle - (minimum allowable)	69 kPa [10 psi]	69 kPa [10 psi]
Lubricating Oil Pressure at Rated - (minimum allowable)	207 kPa [30 psi]	207 kPa [30 psi]
Regulating Valve Opening Pressure	449 kPa [65 psi]	449 kPa [65 psi]
Lubricating Oil Capacity:		
Standard Pan <b>Only</b>	9.5 liters [10 qt]	14.2 liters [15 qt]
Total System - Liters [U.S. qt]	11 liters [11.6 qt]	16.4 liters [17.3 qt]
Low to High	0.9 liter [1 qt]	1.9 liters [2 qt]

**4B Lubrication System Data (nonautomotive)**

	<b>4B3.9</b>	<b>4BT3.9</b>	<b>4BTA3.9</b>
Lubricating Oil Pressure at Idle - (minimum allowable)	69 kPa [10 psi]	69 kPa [10 psi]	69 kPa [10 psi]
Lubricating Oil Pressure at Rated - (minimum allowable)	207 kPa [30 psi]	207 kPa [30 psi]	207 kPa [30 psi]
Regulating Valve Opening Pressure	449 kPa [65 psi]	449 kPa [65 psi]	449 kPa [65 psi]
Lubricating Oil Capacity: Standard Pan <b>Only</b>	9.5 liters [10 qt]	9.5 liters [10 qt]	9.5 liters [10 qt]
Total System	10.9 liters [11.5 qt]	11 liters [11.6 qt]	11 liters [11.6 qt]
Low to High	0.9 liter [1 qt]	0.9 liter [1 qt]	0.9 liter [1 qt]

**6B Lubrication System Data (nonautomotive)**

	<b>6B5.9</b>	<b>6BT5.9</b>	<b>6BTA5.9</b>
Lubricating Oil Pressure at Idle - (minimum allowable)	69 kPa [10 psi]	69 kPa [10 psi]	69 kPa [10 psi]
Lubricating Oil Pressure at Rated - (minimum allowable)	207 kPa [30 psi]	207 kPa [30 psi]	207 kPa [30 psi]
Regulating Valve Opening Pressure	449 kPa [65 psi]	449 kPa [65 psi]	449 kPa [65 psi]
Lubricating Oil Capacity: Standard Pan <b>Only</b>	14.2 liters [15 qt]	14.2 liters [15 qt]	14.2 liters [15 qt]
Total System	16.3 liters [17.2 qt]	16.4 liters [17.3 qt]	16.4 liters [17.3 qt]
Low to High	1.9 liters [2 qt]	1.9 liters [2 qt]	1.9 liters [2 qt]

**Cooling System**

**Cooling System Data (automotive)**

	<b>B3.9</b>	<b>B5.9</b>
Coolant Capacity (engine <b>only</b> )	7 liters [7.4 qt]	10.5 liters [11.1 qt]
Standard Modulating Thermostat Range	Start 83°C [181°F]	Fully Open 95°C [203°F]
Pressure Cap:		
104°C [220°F] Systems	103 kPa [15 psi]	103 kPa [15 psi]
99°C [210°F] Systems	48 kPa [7 psi]	48 kPa [7 psi]

**4B Cooling System Data (nonautomotive)**

	<b>4B3.9</b>	<b>4BT3.9</b>	<b>4BTA3.9</b>
Coolant Capacity (engine <b>only</b> )	7 liters [7.4 qt]	7 liters [7.4 qt]	9.7 liters [10.2 qt]
Standard Modulating Thermostat Range	Start 83°C [181°F]; Fully Open 95°C [203°F]	Start 83°C [181°F]; Fully Open 95°C [203°F]	Start 83°C [181°F]; Fully Open 95°C [203°F]
Pressure Cap:			
104°C [220°F] Systems	103 kPa [15 psi]	103 kPa [15 psi]	103 kPa [15 psi]
99°C [210°F] Systems	48 kPa [7 psi]	48 kPa [7 psi]	48 kPa [7 psi]

**6B Cooling System Data (nonautomotive)**

	<b>6B5.9</b>	<b>6BT5.9</b>	<b>6BTA5.9</b>
Coolant Capacity (engine <b>only</b> )	10.5 liters [11.1 qt]	10.5 liters [11.1 qt]	14.5 liters [15.3 qt]
Standard Modulating Thermostat Range	Start 83°C [181°F]; Fully Open 95°C [203°F]	Start 83°C [181°F]; Fully Open 95°C [203°F]	Start 83°C [181°F]; Fully Open 95°C [203°F]
Pressure Cap:			
104°C [220°F] Systems	103 kPa [15 psi]	103 kPa [15 psi]	103 kPa [15 psi]
99°C [210°F] Systems	48 kPa [7 psi]	48 kPa [7 psi]	48 kPa [7 psi]

**Air Intake System**

**Air Intake System Data (automotive)**

	<b>B3.9</b>	<b>B5.9</b>
Maximum Allowable Intake Restriction at Rated Speed and Loaded with Dirty Air Filter Element	635 mm H <sub>2</sub> O [25 in H <sub>2</sub> O]	635 mm H <sub>2</sub> O [25 in H <sub>2</sub> O]

**4B Air Intake System (nonautomotive)**

	<b>4B3.9</b>	<b>4BT3.9</b>	<b>4BTA3.9</b>
Maximum Allowable Intake Restriction at Rated Speed and Loaded with Dirty Air Filter Element	508 mm H <sub>2</sub> O [20 in H <sub>2</sub> O]	635 mm H <sub>2</sub> O [25 in H <sub>2</sub> O]	635 mm H <sub>2</sub> O [25 in H <sub>2</sub> O]

**6B Air Intake System (nonautomotive)**

	<b>6B5.9</b>	<b>6BT5.9</b>	<b>6BTA5.9</b>
Maximum Allowable Intake Restriction at Rated Speed and Loaded with Dirty Air Filter Element	508 mm H <sub>2</sub> O [20 in H <sub>2</sub> O]	635 mm H <sub>2</sub> O [25 in H <sub>2</sub> O]	635 mm H <sub>2</sub> O [25 in H <sub>2</sub> O]

Refer to the following table for the control parts list (CPL), engine model, engine horsepower rating, and corresponding rated turbocharger boost pressure.

**NOTE:** Measurement of boost pressure is **not** a shortcut to logical troubleshooting. Low power can be caused by the fuel used, filter maintenance, and several engine components. Follow the logic charts for Engine Power Output Low, and measure boost pressure as indicated. Refer to this section, General Information, for measurement instructions.

These pressures are valid **only** at rated conditions (rated speed and power). Any attempt to use the values at engine speeds and loads other than those specified will result in an incorrect diagnosis.

**B Series Engines' Turbocharger Boost Pressure Specifications**

CPL	MODEL EN-GINE	hp @ rpm RATING	PEAK TORQUE ft-lb @ rpm	RATED BOOST (in Hg)			PEAK TORQUE BOOST (in Hg)		
				min	nom	max	min	nom	max
591	4B3.9	64 @ 2200	N/A	N/A	N/A	N/A	N/A	N/A	N/A
591	4B3.9	64 @ 2200	N/A	N/A	N/A	N/A	N/A	N/A	N/A
592	4BTA3.9	70 @ 2100	N/A	11	14	17	N/A	N/A	N/A
592	4BTA3.9	71 @ 2200	N/A	12	15	18	N/A	N/A	N/A
592	4BTA3.9	80 @ 2200	N/A	14	17	20	N/A	N/A	N/A
592	4BTA3.9	92 @ 2100	N/A	16	19	22	N/A	N/A	N/A
592	4BTA3.9	93 @ 2200	N/A	18	21	24	N/A	N/A	N/A
592	4BTA3.9	94 @ 2200	N/A	18	21	24	N/A	N/A	N/A
592	4BTA3.9	96 @ 2300	N/A	19	22	25	N/A	N/A	N/A
592	4BTA3.9	100 @ 2500	N/A	22	25	28	N/A	N/A	N/A
594	4BTA3.9	95 @ 2200	N/A	15	18	21	N/A	N/A	N/A
594	4BTA3.9	112 @ 2300	N/A	21	24	27	N/A	N/A	N/A
594	4BTA3.9	125 @ 2200	N/A	25	28	31	N/A	N/A	N/A
646	4BT3.9	71 @ 1500	N/A	9	12	15	N/A	N/A	N/A
646	4BT3.9	82 @ 1800	N/A	11	14	17	N/A	N/A	N/A
710	4BT3.9	75 @ 2200	N/A	13	16	19	N/A	N/A	N/A
710	4BT3.9	100 @ 2500	N/A	22	25	28	N/A	N/A	N/A
711	4BT3.9	71 @ 1500	N/A	9	12	15	N/A	N/A	N/A
711	4BT3.9	82 @ 1800	N/A	11	14	17	N/A	N/A	N/A
721	4B3.9	80 @ 2800	N/A	N/A	N/A	N/A	N/A	N/A	N/A
730	4BT3.9	85 @ 2500	235 @ 1200	17	20	23	9	10	11
730	4BT3.9	91 @ 2200	259 @ 1400	17	20	23	11	12	13
741	4BT3.9	130 @ 2500	N/A	18	21	24	N/A	N/A	N/A
741	4BT3.9	150 @ 2800	N/A	25	28	31	N/A	N/A	N/A
741	4BT3.9	150 @ 2800	N/A	25	28	31	N/A	N/A	N/A
762	4BT3.9	105 @ 2500	N/A	28	32	36	N/A	N/A	N/A
762	4BT3.9	105 @ 2800	N/A	31	35	39	N/A	N/A	N/A
763	4BT3.9	67 @ 2200	N/A	10	14	16	N/A	N/A	N/A
763	4BT3.9	71 @ 2200	N/A	10	14	16	N/A	N/A	N/A
767	4BT3.9	105 @ 2500	N/A	24	28	31	N/A	N/A	N/A
767	4BT3.9	105 @ 2800	N/A	27	30	33	N/A	N/A	N/A
826	4BT3.9	87 @ 1500	N/A	15	18	21	N/A	N/A	N/A
857	4BT3.9	120 @ 2500	N/A	40	44	48	N/A	N/A	N/A
858	4BT3.9	105 @ 2500	N/A	35	39	43	N/A	N/A	N/A
937	4BT3.9	74 @ 1500	N/A	10	13	16	N/A	N/A	N/A
971	4BT3.9	96 @ 2200	N/A	19	22	25	N/A	N/A	N/A
971	4BT3.9	100 @ 2500	N/A	22	25	28	N/A	N/A	N/A
986	4BTA3.9	120 @ 2500	N/A	28	31.0	34	17	19.4	21
1201	4BT3.9	80 @ 2500	N/A	19	22	25	N/A	N/A	N/A
1202	4BT3.9	74 @ 2500	N/A	18	21	24	N/A	N/A	N/A
1260	4BTA3.9	105 @ 2500	N/A	22	24.5	27	14	15.6	17
1268	4BT3.9	105 @ 2500	N/A	28	32	36	N/A	N/A	N/A
1520	4BTG2	104 @ 1800	N/A	19	21	23	N/A	N/A	N/A
1521	4BT3.9	74 @ 1500	N/A	3.4	6.4	9.4	N/A	N/A	N/A

(Continued)



CPL	MODEL EN-GINE	hp @ rpm RATING	PEAK TORQUE ft-lb @ rpm	RATED BOOST (in Hg)			PEAK TORQUE BOOST (in Hg)		
				min	nom	max	min	nom	max
1521	4BT3.9	86 @ 1800	N/A	5.8	8.8	12.0	N/A	N/A	N/A
1521	4BT3.9	88 @ 1800	N/A	19	21	23	N/A	N/A	N/A
1525	4BT3.9	72 @ 1500	N/A	N/A	N/A	N/A	N/A	N/A	N/A
1525	4BTG2	87 @ 1500	N/A	12	13	14	N/A	N/A	N/A
1963	4BTA3.9	116 @ 2500	295 @ 1500	36	39.3	42	23	25.6	29
1963	4BTA3.9	116 @ 2500	299 @ 1500	37	39.9	43	23	26	29
1963	4BTA3.9	125 @ 2200	350 @ 1500	37	40	43	29	32	35
1963	4BTA3.9	130 @ 2500	344 @ 1500	36	39	42	27	30	33
1965	4BT3.9	80 @ 2200	229 @ 1500	39	42	45	17	20	23
1965	4BT3.9	85 @ 2200	242 @ 1500	43	46	49	19	22	25
1965	4BTA3.9	85 @ 2200	254 @ 1500	43	46	49	19	22	25
1965	4BT3.9	90 @ 2200	269 @ 1500	45	49	53	22	26	30
1965	4BT3.9	92 @ 2100	293 @ 1500	46	49.3	52	28	31	34
1965	4BT3.9	92 @ 2100	295 @ 2100	45	49	53	25	29	33
1966	4BT3.9	92 @ 2000	302 @ 1300	31	33.7	37	20	22.7	26
1967	4BT3.9	85 @ 2500	239 @ 1500	38	41.5	45	16	20	24
1967	4BT3.9	90 @ 2500	254 @ 1500	38	42	45	20	24	28
1967	4BT3.9	95 @ 2200	285 @ 1500	38	42.2	45	24	27.9	32
1967	4BT3.9	100 @ 2200	298 @ 1500	41	44	47	27	30	33
1967	4BT3.9	105 @ 2100	293 @ 1500	39	42.3	45	26	29.2	32
1967	4BT3.9	105 @ 2400	280 @ 1500	41	44.3	47	23	26.6	31
1967	4BT3.9	110 @ 2500	293 @ 1500	42	44.8	48	25	29	33
2021	4BT3.9	93 @ 2200	353 @ 1550	N/A	N/A	N/A	N/A	N/A	N/A
2109	4BTA3.9	107 @ 2100	327 @ 1500	40	42.7	46	30	32.5	36
2109	4BTA3.9	107 @ 2100	334 @ 1500	39	42	45	30	33	36
2109	4BTA3.9	107 @ 2100	328 @ 1600	40	42.7	46	30	32.5	36
2109	4BTA3.9	110 @ 2200	328 @ 1500	39	42	45	30	33	36
2109	4BTA3.9	110 @ 2200	328 @ 1500	39	42.0	45	30	33	36
2109	4BTA3.9	110 @ 2200	333 @ 1500	39	41.7	45	30	33.3	36
2109	4BTA3.9	116 @ 2500	300 @ 1500	39	42	45	29	32	35
2109	4BTA3.9	116 @ 2500	312 @ 1500	40	43	46	29	32	35
2264	4BTA3.9	125 @ 2200	355 @ 1500	36	39	42	29	32	35
2302	4BT3.9	110 @ 2500	278 @ 1500	41	43.7	47	24	26.6	30
2302	4BT3.9	110 @ 2500	278 @ 1500	40	43	46	23	26	29
2302	4BT3.9	110 @ 2500	293 @ 1500	41	43.7	47	26	28.6	32
2351	4BTA3.9	110 @ 2200	328 @ 1500	37	39.9	43	27	29.5	33
2359	4BT3.9	85 @ 2500	239 @ 1500	39	41.5	45	17	20	23
2361	4B3.9	74 @ 2500	201 @ 1200	N/A	N/A	N/A	N/A	N/A	N/A
2361	4B3.9	80 @ 2500	201 @ 1200	N/A	N/A	N/A	N/A	N/A	N/A
2361	4B3.9	80 @ 2500	201 @ 1200	N/A	N/A	N/A	N/A	N/A	N/A
2374	4B3.9	75 @ 2200	201 @ 1200	N/A	N/A	N/A	N/A	N/A	N/A
2478	4BT3.9	80 @ 2200	229 @ 1500	39	41.8	45	17	20	23
2486	4B3.9	75 @ 2200	201 @ 1200	N/A	N/A	N/A	N/A	N/A	N/A
2488	4B3.9	54 @ 2000	179 @ 1200	N/A	N/A	N/A	N/A	N/A	N/A
2489	4B3.9	60 @ 2200	179 @ 1200	N/A	N/A	N/A	N/A	N/A	N/A
2490	4B3.9	67 @ 2200	192 @ 1200	N/A	N/A	N/A	N/A	N/A	N/A
2599	4B3.9	75 @ 2200	193 @ 1200	N/A	N/A	N/A	N/A	N/A	N/A
2599	4B3.9	80 @ 2500	193 @ 1200	N/A	N/A	N/A	N/A	N/A	N/A
2601	4B3.9	60 @ 2000	180 @ 1200	N/A	N/A	N/A	N/A	N/A	N/A
2601	4 B3.9	60 @ 2000	190 @ 1200	N/A	N/A	N/A	N/A	N/A	N/A
2808	4BT3.9	110 @ 2500	293 @ 1500	41	43.7	47	24	26.6	30
596	6B5.9	93 @ 2200	262 @ 1100	N/A	N/A	N/A	N/A	N/A	N/A
598	6BT5.9	160 @ 2500	N/A	28	32	36	N/A	N/A	N/A
598	6BT5.9	160 @ 2800	N/A	31	35	39	N/A	N/A	N/A
600	6BTA5.9	180 @ 2500	N/A	39	43	47	N/A	N/A	N/A

(Continued)

CPL	MODEL EN-GINE	hp @ rpm RATING	PEAK TORQUE ft-lb @ rpm	RATED BOOST (in Hg)			PEAK TORQUE BOOST (in Hg)		
				min	nom	max	min	nom	max
692	6BT5.9	160 @ 2500	N/A	30	34	38	N/A	N/A	N/A
692	6BT5.9	160 @ 2600	N/A	31	35	39	N/A	N/A	N/A
697	6BT5.9	113 @ 1500	N/A	15	19	21	N/A	N/A	N/A
697	6BT5.9	134 @ 1800	N/A	21	24	27	N/A	N/A	N/A
713	6BT5.9	113 @ 1500	N/A	12	18	21	N/A	N/A	N/A
713	6BT5.9	134 @ 1800	N/A	21	24	27	N/A	N/A	N/A
715	6BTA5.9	143 @ 2100	N/A	26	29	32	N/A	N/A	N/A
716	6BT5.9	156 @ 2500	N/A	45	49	53	N/A	N/A	N/A
728	6BT5.9	128 @ 2800	N/A	19	22	25	N/A	N/A	N/A
728	6BT5.9	130 @ 2650	N/A	19	22	25	N/A	N/A	N/A
729	6BT5.9	134 @ 2200	N/A	23	26	29	N/A	N/A	N/A
742	6BT5.9	152 @ 2500	N/A	30	33	36	N/A	N/A	N/A
742	6BT5.9	180 @ 2500	N/A	39	43	47	N/A	N/A	N/A
742	6BT5.9	210 @ 2600	N/A	47	51	55	N/A	N/A	N/A
766	6BT5.9	160 @ 2500	N/A	28	32	36	N/A	N/A	N/A
766	6BT5.9	160 @ 2800	N/A	31	35	39	N/A	N/A	N/A
791	6B5.9	120 @ 2800	N/A	N/A	N/A	N/A	N/A	N/A	N/A
791	6B5.9	120 @ 2800	N/A	N/A	N/A	N/A	N/A	N/A	N/A
804	6BT5.9	145 @ 2600	N/A	39	43	47	N/A	N/A	N/A
804	6BT5.9	160 @ 2500	N/A	38	41	44	N/A	N/A	N/A
807	6BT5.9	99 @ 2200	N/A	13	16	19	N/A	N/A	N/A
834	6BTA5.9	180 @ 2500	N/A	32	36	40	N/A	N/A	N/A
856	6BTA5.9	180 @ 2500	N/A	46	50	54	N/A	N/A	N/A
912	6BTA5.9	190 @ 2600	N/A	34	38	42	N/A	N/A	N/A
938	6BT5.9	135 @ 2200	442 @ 1400	23	25	28	19	21	23
938	6BT5.9	137 @ 2200	393 @ 1600	18	21	24	16	18	20
938	6BT5.9	140 @ 2200	426 @ 1300	24	27	30	15	17	19
938	6BT5.9	145 @ 2200	425 @ 1500	25	28	31	19	21	23
938	6BT5.9	87 @ 2200	265 @ 1200	10	13	16	5	6	7
938	6BT5.9	97 @ 2200	270 @ 1200	13	16	19	6	7	8
943	6BT5.9	120 @ 2100	N/A	18	21	24	N/A	N/A	N/A
947	6BT5.9	145 @ 2600	N/A	24	27	30	N/A	N/A	N/A
947	6BT5.9	160 @ 2500	N/A	29	33	37	N/A	N/A	N/A
947	6BT5.9	160 @ 2600	N/A	31	35	39	N/A	N/A	N/A
947	6BT5.9	130 @ 2500	N/A	20	23	26	N/A	N/A	N/A
948	6BT5.9	145 @ 2600	N/A	24	27	30	N/A	N/A	N/A
949	6BT5.9	88 @ 2000	N/A	10	13	16	N/A	N/A	N/A
949	6BT5.9	121 @ 2200	N/A	14	17	20	N/A	N/A	N/A
949	6BT5.9	124 @ 2400	N/A	21	24	27	N/A	N/A	N/A
949	6BT5.9	126 @ 2100	N/A	19	22	25	N/A	N/A	N/A
949	6BT5.9	130 @ 2500	N/A	23	26	29	N/A	N/A	N/A
949	6BT5.9	140 @ 2200	N/A	24	27	30	N/A	N/A	N/A
949	6BT5.9	142 @ 2100	N/A	24	24	30	N/A	N/A	N/A
949	6BT5.9	145 @ 2200	N/A	25	28	31	N/A	N/A	N/A
949	6BT5.9	148 @ 2300	N/A	27	30	33	N/A	N/A	N/A
949	6BT5.9	152 @ 2500	N/A	28	32	36	N/A	N/A	N/A
950	6BT5.9	120 @ 2100	N/A	18	21	24	N/A	N/A	N/A
953	6BTA5.9	220 @ 2500	N/A	23	26	29	N/A	N/A	N/A
953	6BTA5.9	250 @ 2600	N/A	44	48	52	N/A	N/A	N/A
961	6BT5.9	115 @ 1500	N/A	16	19	22	N/A	N/A	N/A
961	6BT5.9	135 @ 1800	N/A	22	25	28	N/A	N/A	N/A
970	6BTA-M2	250 @ 2600	N/A	32	36	40	N/A	N/A	N/A
970	6BTA-M2	300 @ 2800	N/A	46	50	54	N/A	N/A	N/A
970	6BTSWA	300 @ 2800	N/A	40	44	48	N/A	N/A	N/A
983	6BTA5.9	157 @ 2500	N/A	35	39	43	N/A	N/A	N/A
983	6BTA5.9	177 @ 2500	N/A	38	42	46	N/A	N/A	N/A

(Continued)

CPL	MODEL EN-GINE	hp @ rpm RATING	PEAK TORQUE ft-lb @ rpm	RATED BOOST (in Hg)			PEAK TORQUE BOOST (in Hg)		
				min	nom	max	min	nom	max
998	6BTA5.9	200 @ 2500	N/A	45	49	53	N/A	N/A	N/A
1160	6BT5.9	160 @ 2500	N/A	29	33	37	N/A	N/A	N/A
1165	6BTA5.9	227 @ 1760	N/A	37	41	45	N/A	N/A	N/A
1165	6BTA5.9	255 @ 2100	N/A	46	50	54	N/A	N/A	N/A
1168	6BT5.9	148 @ 2300	N/A	25	28	31	N/A	N/A	N/A
1168	6BT5.9	152 @ 2500	N/A	27	31	35	N/A	N/A	N/A
1209	6BTA5.9	176 @ 2300	N/A	30	33	36	N/A	N/A	N/A
1266	6BT5.9	142 @ 2500	N/A	27	31	35	N/A	N/A	N/A
1279	6BT5.9	125 @ 2200	412 @ 1400	18	20	22	14	16	18
1322	6BTA-M1	220 @ 2500	N/A	32	36	40	N/A	N/A	N/A
1322	6BTA5.9	250 @ 2600	N/A	34	38	42	N/A	N/A	N/A
1322	6BTA-M1	250 @ 2600	N/A	42	46	50	N/A	N/A	N/A
1419	6BT5.9	250 @ 2500	N/A	38	42	46	N/A	N/A	N/A
1518	6BT5.9	169 @ 1800	N/A	32	35	39	N/A	N/A	N/A
1549	6BTA5.9	160 @ 2500	400 @ 1600	30	34	38	23	25	28
1552	6BTA5.9	210 @ 2500	485 @ 1600	44	47.7	52	29	31.9	35
1570	6BTJWA	250 @ 2600	N/A	35	39	43	N/A	N/A	N/A
1579	6BTA5.9	160 @ 2500	400 @ 1600	31	35.4	39	14	17.2	20
1613	6BTSWA	250 @ 2600	N/A	36	40	44	N/A	N/A	N/A
1640	6BTA5.9	185 @ 2200	531 @ 1500	41	45	50	27	30	33
1863	6BTAA	180 @ 2500	42 @ 1500	36	39	42	22	25	28
1889	6BTA5.9	185 @ 2400	550 @ 1500	43	46	49	30	33	36
1889	6BTA5.9	200 @ 2500	550 @ 1500	48	51	54	30	33	36
1914	6BTA5.9	190 @ 2300	475 @ 1600	44	48	52	22	26	30
1945	6BT5.9	200 @ 2200	583 @ 1500	41	46	51	31	34	37
1945	6BTA5.9	200 @ 2500	581 @ 1500	41	46	51	30	33	36
1948	6BT5.9	148 @ 2200	440 @ 1600	38	41	44	25	28	31
1948	6BT5.9	148 @ 2200	440 @ 1600	37	40	43	43	24	37
1948	6BT5.9	152 @ 2500	414 @ 1600	40	43	46	24	27	30
1948	6BT5.9	155 @ 2100	449 @ 1600	39	41.8	45	24	27	30
1959	6BTA5.9	160 @ 2500	400 @ 1600	30	34	38	18	21	24
1962	6BTA5.9	147 @ 2000	428 @ 1500	33	36	39	21	24	27
1962	6BTA5.9	150 @ 2200	466 @ 1500	35	38	41	23	26	29
1962	6BTA5.9	150 @ 2200	466 @ 1500	35	38	41	23	26	29
1962	6BTA5.9	150 @ 2200	483 @ 1500	35	38.4	41	26	28.6	32
1962	6BTA5.9	160 @ 2000	462 @ 1500	38	41	44	23	26	29
1962	6BTA5.9	166 @ 2075	474 @ 1500	42	44.6	48	25	28.1	31
1962	6BTA5.9	167 @ 2000	480 @ 1500	36	39	42	24	27	30
1962	6BTA5.9	150 @ 2200	483 @ 1500	35	38	41	26	29	32
1962	6BTA5.9	153 @ 2200	485 @ 1500	37	40	43	24	27	30
1962	6BTA5.9	165 @ 2200	512 @ 1500	42	45	48	28	31	34
1962	6BTA5.9	165 @ 2200	532 @ 1500	42	44.6	48	29	31.6	35
1962	6BTA5.9	168 @ 2200	541 @ 1500	37	40	43	24	27	30
1962	6BTA5.9	167 @ 2000	479 @ 1500	40	43	46	25	28	31
1962	6BTA5.9	170 @ 2300	475 @ 1500	42	45	48	23	26	29
1962	6BTA5.9	169 @ 2100	480 @ 1500	41	44	47	25	28	31
1962	6BTA5.9	169 @ 2100	480 @ 1500	41	44	47	25	28	31
1968	6BTAA	160 @ 2500	400 @ 1600	30	34	38	19	22	25
1975	6BTA5.9	330 @ 2800	687 @ 2000	52	57	62	37	41	45
1989	6BTA5.9	185 @ 2500	553 @ 1500	47	51	55	33	37	41
2016	6BTAA5.9	129 @ 2500	347 @ 1500	25	29.2	33	11	13.9	17
2017	6BTA5.9	178 @ 2500	474 @ 1500	34	36.6	40	19	21.6	25
2023	6BTAA	21 @ 2600	440 @ 1600	48	51	54	23	26	29
2035	6BTA5.9	195 @ 2800	420 @ 1600	32	35	38	25	28.5	31
2063	6BTA5.9	185 @ 2300	580 @ 1500	40	43	46	33	36	39
2063	6BTA5.9	185 @ 2400	558 @ 1500	46	48.7	52	30	33.1	36

(Continued)

CPL	MODEL EN-GINE	hp @ rpm RATING	PEAK TORQUE ft-lb @ rpm	RATED BOOST (in Hg)			PEAK TORQUE BOOST (in Hg)		
				min	nom	max	min	nom	max
2063	6BTA5.9	185 @ 2200	566 @ 1500	40	43	46	33	36	39
2063	6BTA5.9	174 @ 2200	590 @ 1500	45	48	51	36	39	42
2071	6BT5.9	97 @ 2200	267 @ 1700	21	24	27	13	16	19
2071	6BT5.9	97 @ 2200	270 @ 1700	20	24	28	12	16	20
2071	6BT5.9	101 @ 2200	313 @ 1500	23	26	29	11	14	17
2071	6BT5.9	118 @ 2400	327 @ 1600	35	38	41	16	19	22
2071	6BT5.9	110 @ 1900	341 @ 1600	27	30	33	17	20	23
2071	6BT5.9	110 @ 2200	341 @ 1600	28	31	34	18	21	24
2071	6BT5.9	120 @ 2200	372 @ 1500	32	35	38	22	25	28
2071	6BT5.9	126 @ 2100	380 @ 1600	29	32	35	19	22	25
2071	6BT5.9	130 @ 2200	388 @ 1600	33	36	39	20	23	26
2071	6BT5.9	130 @ 2500	368 @ 1600	42	44.9	48	18	21	24
2071	6BT5.9	135 @ 2100	404 @ 1600	30	33	36	19	22	25
2071	6BT5.9	135 @ 2200	419 @ 1500	32	35	38	19	22	25
2071	6BT5.9	135 @ 2200	419 @ 1600	35	38	41	23	26	29
2071	6BT5.9	135 @ 2400	379 @ 1600	42	45	48	21	24	27
2071	6BT5.9	135 @ 2200	419 @ 1600	37	40	43	25	28	31
2071	6BT5.9	135 @ 2100	419 @ 1500	30	33	36	19	22	25
2071	6BT5.9	140 @ 2000	416 @ 1600	32	35	38	23	26	29
2071	6BT5.9	145 @ 2100	438 @ 1500	38.4	41.4	44.4	40	42.1	44
2071	6BT5.9	137 @ 2000	440 @ 1600	32	35.1	38	28	31	34
2072	6BTA5.9	174 @ 2500	458 @ 1500	43	46.1	49	24	27.2	30
2072	6BTA5.9	174 @ 2500	470 @ 1500	42	45	48	24	27	30
2174	6BTAA5.9	180 @ 2500	420 @ 1500	36	39	42	22	25	28
2175	6BTAA5.9	215 @ 2600	440 @ 1600	48	51	54	23	26	29
2122	6BTA5.9	177 @ 2500	480 @ 1500	N/A	N/A	N/A	N/A	N/A	N/A
2208	6BTA	370 @ 3000	726 @ 2200	56	59	62	40	43	46
2249	6BTAA5.9	232 @ 2500	590 @ 1500	50	52.6	56	30	32.5	36
2292	6BTA5.9	147 @ 2000	438 @ 1500	35	38	41	23	26	29
2292	6BTA5.9	160 @ 1900	479 @ 1500	38	41	44	23	26	29
2292	6BTA5.9	169 @ 2100	480 @ 1500	41	44	47	25	28	31
2292	6BTA5.9	169 @ 2100	485 @ 1500	41	44	47	23	26	29
2292	6BTA5.9	169 @ 2100	485 @ 1500	45	47.5	51	29	31.6	35
2292	6BTA5.9	167 @ 2000	480 @ 1500	37	39.6	43	25	27.5	31
2308	6BTAA5.9	180 @ 2500	420 @ 1500	36	39	42	22	25	28
2479	6BTA5.9	174 @ 2200	590 @ 1500	46	48.4	51	37	39.9	43
2530	6BT5.9	135 @ 1800	N/A	30	32.5	35	N/A	N/A	N/A
2530	6BT5.9	143 @ 1800	N/A	29	31.9	35	N/A	N/A	N/A
2530	6BT5.9	170 @ 1800	N/A	20	21.8	23	N/A	N/A	N/A

**Exhaust System**

**Exhaust System Data (automotive)**

	<b>B3.9</b>	<b>B5.9</b>
Maximum Allowable Exhaust Restriction at Rated Speed and Loaded (1991 EPA certified)	114.3 mm Hg [4.5 in Hg]	114.3 mm Hg [4.5 in Hg]
Maximum Allowable Exhaust Restriction at Rated Speed and Loaded (1994 EPA certified)	152.4 mm Hg [6 in Hg] with oxidation catalyst	152.4 mm Hg [6 in Hg] with oxidation catalyst

**4B Exhaust System Data (nonautomotive)**

<b>EXHAUST SYSTEM</b>	<b>4B3.9</b>	<b>4BT3.9</b>	<b>4BTA3.9</b>
Maximum Allowable Exhaust Restriction at Rated Speed and Loaded	76.2 mm Hg [3.0 in Hg]	76.2 mm Hg [3.0 in Hg]	76.2 mm Hg [3.0 in Hg]

**6B Exhaust System Data (nonautomotive)**

<b>EXHAUST SYSTEM</b>	<b>6B5.9</b>	<b>6BT5.9</b>	<b>6BTA5.9</b>
Maximum Allowable Exhaust Restriction at Rated Speed and Loaded	76.2 mm Hg [3.0 in Hg]	76.2 mm Hg [3.0 in Hg]	76.2 mm Hg [3.0 in Hg]

**Compressed Air System**

**A/C Model QE296 Specifications**

Compressor Swept Volume at 1250 rpm .....	6.2 L/sec [13.2 SCFM]
Piston Displacement .....	296 cc [18.06 C.I.D.]
Bore .....	92.08 mm [3.625 in]
Stroke .....	44.45 mm [1.750 in]
Speed .....	1.135 x Engine rpm
Cooling .....	Engine Coolant
Lubrication .....	Engine Lubricating Oil
Plumbing Line Sizes:	
Coolant Inlet and Outlet (pipe fitting) .....	1/2-in NPTF [0.50 in]
Air Inlet (inside diameter) .....	19-mm [0.75-in] Nipple
Air Outlet (minimum inside diameter) .....	1/2-in NPTF [0.50 in]
Height, Overall (approximate) .....	305 mm [12 in]
Width, Overall (approximate) .....	159 mm [6.25 in]
Length, Overall (approximate) .....	267 mm [10.5 in]
Weight (approximate) .....	20 kg [44 lb]

**A/C Model QE338 Specifications**

Compressor Swept Volume at 1250 rpm .....	7.1 L/sec [15 SCFM]
Piston Displacement .....	338 cc [20.6 C.I.D.]
Bore .....	98.43 mm [3.875 in]
Stroke .....	44.45 mm [1.750 in]
Speed .....	1.135 x Engine rpm
Cooling .....	Engine Coolant
Lubrication .....	Engine Lubricating Oil
Plumbing Line Sizes:	
Coolant Inlet and Outlet (pipe fitting) .....	1/2-in NPTF [0.50 in]
Air Inlet (inside diameter) .....	19-mm [0.75-in] Nipple
Air Outlet (minimum inside diameter) .....	1/2-in NPTF [0.50 in]
Height, Overall (approximate) .....	305 mm [12 in]
Width, Overall (approximate) .....	159 mm [6.25 in]
Length, Overall (approximate) .....	267 mm [10.5 in]
Weight (approximate) .....	18 kg [40 lb]

**A/C Model HD650 Specifications**

Compressor Swept Volume at 1250 rpm .....	6.2 L/sec [13.2 SCFM]
Piston Displacement .....	296 cc [18.06 C.I.D.]
Bore .....	92.08 mm [3.625 in]
Stroke .....	44.45 mm [1.750 in]
Speed .....	1.135 x Engine rpm
Cooling .....	Engine Coolant
Lubrication .....	Engine Lubricating Oil
Plumbing Line Sizes:	

Coolant Inlet and Outlet (pipe fitting) .....	1/2-in NPTF [0.50 in]
Air Inlet (inside diameter) .....	19-mm [0.75-in] Nipple
Air Outlet (minimum inside diameter) .....	1/2-in NPTF [0.50 in]
Height, Overall (approximate) .....	305 mm [12 in]
Width, Overall (approximate) .....	159 mm [6.25 in]
Length, Overall (approximate) .....	267 mm [10.5 in]
Weight (approximate) .....	20 kg [44 lb]

**A/C Model HD850 Specifications**

Compressor Swept Volume at 1250 rpm .....	7.1 L/sec [15 SCFM]
Piston Displacement .....	338 cc [20.6 C.I.D.]
Bore .....	98.43 mm [3.875 in]
Stroke .....	44.45 mm [1.750 in]
Speed .....	1.135 x Engine rpm
Cooling .....	Engine Coolant
Lubrication .....	Engine Lubricating Oil
Plumbing Line Sizes:	
Coolant Inlet and Outlet (pipe fitting) .....	1/2-in NPTF [0.50 in]
Air Inlet (inside diameter) .....	19-mm [0.75-in] Nipple
Air Outlet (minimum inside diameter) .....	1/2-in NPTF [0.50 in]
Height, Overall (approximate) .....	305 mm [12 in]
Width, Overall (approximate) .....	159 mm [6.25 in]
Length, Overall (approximate) .....	267 mm [10.5 in]
Weight (approximate) .....	18 kg [40 lb]



**A/C Model SS191 Specifications**

Compressor Swept Volume at 1250 rpm .....	4.0 L/sec [8.5 SCFM]
Piston Displacement .....	191 cc [11.65 C.I.D.]
Bore .....	80 mm [3.15 in]
Stroke .....	38.1 mm [1.50 in]
Speed .....	1.135 x Engine rpm
Cooling .....	Engine Coolant
Lubrication .....	Engine Lubricating Oil
<b>Plumbing Line Sizes:</b>	
Coolant Inlet and Outlet (pipe fitting) .....	1/2-in NPTF [0.50 in]
Air Inlet (inside diameter) .....	19-mm [0.75-in] Nipple
Air Outlet (minimum inside diameter) .....	1/2-in NPTF [0.50 in]
Height, Overall (approximate) .....	289 mm [11.4 in]
Width, Overall (approximate) .....	125 mm [4.9 in]
Length, Overall (approximate) .....	186 mm [7.32 in]
Weight (approximate) .....	13.6 kg [30 lb]

**Electrical System**

**Electrical System Data (automotive)**

	B3.9	B5.9
<b>Minimum Recommended Battery Capacity</b>		
@ -18°C [0°F]		
<b>With Light Accessories*</b>		
12-VDC Starter	625CCA	800CCA
24-VDC Starter	400CCA	400CCA
<b>With Heavy Accessories**</b>		
12-VDC Starter	800CCA	950CCA
24-VDC Starter	400CCA	475CCA
<b>Maximum Allowable Resistance of Starting Circuit</b>		
With 12-VDC Starter - Ohms	0.0012	0.0012
With 24-VDC Starter - Ohms	0.0020	0.0020

\*Typical light accessories include alternator, small steering pump, and disengaged clutch.

\*\*Typical heavy accessories include hydraulic pump and torque converter.

4B Electrical System Data (nonautomotive)

	4B3.9	4BT3.9	4BTA3.9
<b>Minimum Recommended Battery Capacity @ -18°C [0°F]</b>			
<b>With Light Accessories*</b>			
12-VDC Starter	625CCA	625CCA	625CCA
24-VDC Starter	312CCA	400CCA	400CCA
<b>With Heavy Accessories**</b>			
12-VDC Starter	800CCA	800CCA	800CCA
24-VDC Starter	400CCA	400CCA	400CCA
<b>Maximum Allowable Resistance of Starting Circuit</b>			
With 12-VDC Starter - Ohms	0.0012	0.0012	0.0012
With 24-VDC Starter - Ohms	0.0020	0.0020	0.0020

\* Typical light accessories include alternator, small steering pump, and disengaged clutch.

\*\* Typical heavy accessories include hydraulic pump and torque converter.

6B Electrical System Data (nonautomotive)

	6B5.9	6BT5.9	6BTA5.9
<b>Minimum Recommended Battery Capacity @ -18°C [0°F]</b>			
<b>With Light Accessories*</b>			
12-VDC Starter	800CCA	800CCA	800CCA
24-VDC Starter	400CCA	400CCA	400CCA
<b>With Heavy Accessories**</b>			
12-VDC Starter	950CCA	950CCA	950CCA
24-VDC Starter	475CCA	475CCA	475CCA
<b>Maximum Allowable Resistance of Starting Circuit</b>			
With 12-VDC Starter - Ohms	0.0012	0.0012	0.0012
With 24-VDC Starter - Ohms	0.0020	0.0020	0.0020

\* Typical light accessories include alternator, small steering pump, and disengaged clutch.

\*\* Typical heavy accessories include hydraulic pump and torque converter.

**Engine Testing**

Maintain the following limits (see note) during a chassis dynamometer test:

Intake Restriction (maximum)

Clean Filter:

Light-Duty .....	254 mm H <sub>2</sub> O [10 in H <sub>2</sub> O]
Medium-Duty .....	305 mm H <sub>2</sub> O [12 in H <sub>2</sub> O]
Heavy-Duty .....	381 mm H <sub>2</sub> O [15 in H <sub>2</sub> O]

Dirty Filter:

Light-Duty .....	635 mm [25 in]
Medium-Duty .....	635 mm [25 in]
Heavy-Duty .....	635 mm [25 in]

Exhaust Back Pressure (maximum) Nonautomotive ..... 76 mm Hg [3.0 in Hg]

Exhaust Back Pressure (maximum) Automotive with Catalyst .. 152 mm Hg [6.0 in Hg] to 127 mm Hg [5.0 in Hg]

Back Pressure (maximum) Automotive without Catalyst ..... 114 mm Hg [4.5 in Hg] to 102 mm Hg [4.0 in Hg]

Oil Pressure:

Low Idle (minimum allowable) .....	69 kPa [10 psi]
Rated Speed (minimum allowable) .....	207 kPa [30 psi]

Fuel Inlet Restriction (maximum) ..... 100 mm Hg [4 in Hg]

Fuel Return Restriction (maximum) ..... 518 mm Hg [20.4 in Hg]

**NOTE:** Due to variations in ratings of different engine models, refer to the specific engine data sheet for the particular engine model being tested.

**Batteries (Specific Gravity)**

Specific Gravity at 27°C [80°F]	State of Charge
1.260 to 1.280	100%
1.230 to 1.250	75%
1.200 to 1.220	50%
1.170 to 1.190	25%
1.110 to 1.130	Discharged

**Battery Cable Specifications**

Cable Size Gauge	Nominal Resistance in Ohms		Maximum Total Length (sum of both cables)			
	Per Meter	Per Foot	12 VDC		24 VDC	
			Meter	Feet	Meter	Feet
4	0.000984	0.00030	NR*	NR*	2.03	6.7
2	0.000615	0.000188	1.63	5.3	3.26	10.6
1	0.000492	0.000150	2.03	6.7	4.06	13.4
0	0.000386	0.000118	2.59	8.5	5.18	17.0
00	0.000292	0.000090	3.43	11.3	6.86	22.6
000	0.000232	0.000071	4.32	14.2	8.64	28.4

\* Not recommended

Wiring Size Recommendations - Starter and Fuel Solenoid

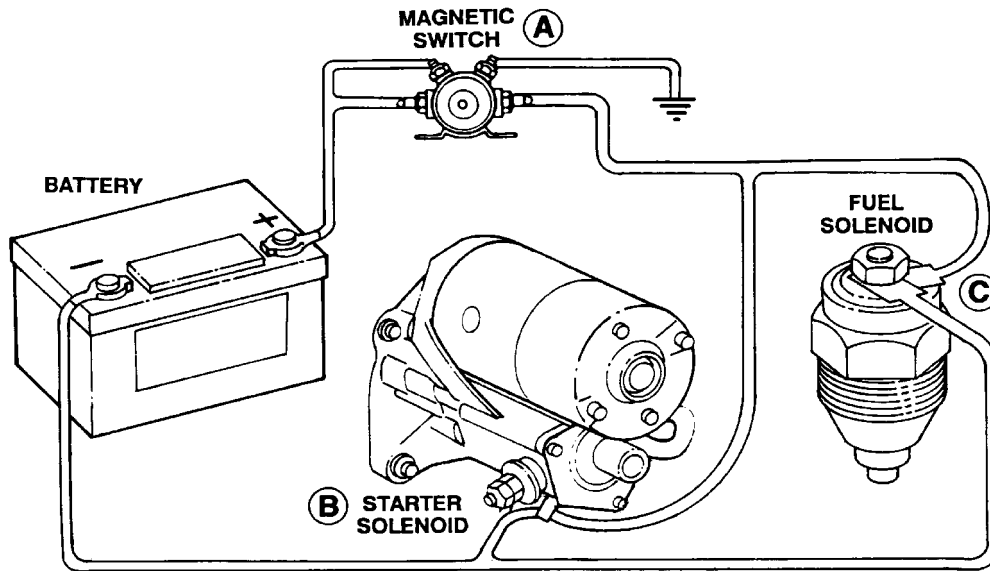

ea900gc

Recommended Wire Gauge Table (Values in table are AWG. size for 12/24-VDC systems)			
Wire Length in Circuit	Battery to A	A to B	A to C
0.91 m [3 ft]	10/14	12/14	14/16
1.21 m [4 ft]	10/12	10/14	14/16
1.52 m [5 ft]	8/10	10/12	14/16
2.74 m [9 ft]	6/8	8/10	12/14
5.49 m [18 ft]	4/6	6/8	8/10

Wire length in circuit means total length in each individual circuit, e.g., Battery to A equals one circuit.

For example, in a 12-VDC circuit:

Battery to A = 1.52 m [5 ft]; gauge required = 8 gauge

A to B = 1.52 m [5 ft]; gauge required = 10 gauge

A to C = 2.74 m [9 ft]; gauge required = 12 gauge.

If the system is double-pole wiring (no frame ground), then the fuel and starter solenoid circuit lengths would include the return cable run to the battery negative (-) post.

## Engine Diagrams

### Engine Views

The following illustrations show the locations of the major external engine components, filters, and other service and maintenance points. Some external components will be at different locations for different engine models.

**NOTE:** The illustrations are **only** a reference to show a typical engine.

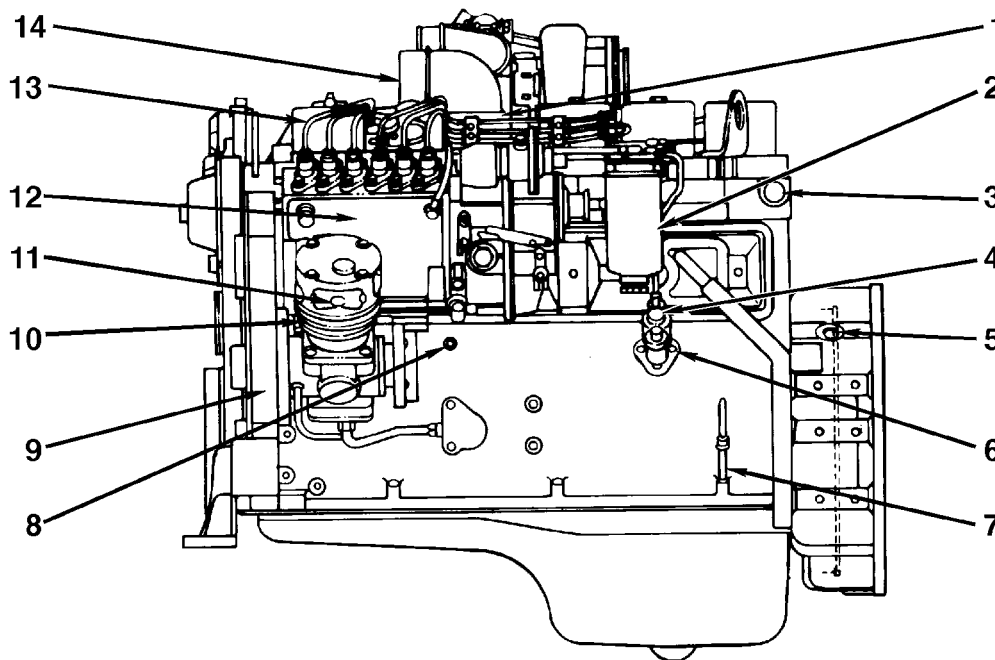

00900132

**Fuel Pump Side View**

- |  |                                 |
|--|---------------------------------|
| 1. Intake air heater (if equipped)     | 8. 1/8-inch NPTF oil pressure   |
| 2. Fuel filter and water separator     | 9. Engine dataplate             |
| 3. 3/4-inch NPTF water heater          | 10. Air compressor              |
| 4. 1/4-inch NPTF fuel inlet connection | 11. Air compressor air intake   |
| 5. 3/4-16 UNF magnetic pickup location | 12. In-line fuel injection pump |
| 6. Fuel lift pump                      | 13. High-pressure fuel lines    |
| 7. Oil dipstick                        | 14. Engine air inlet.           |

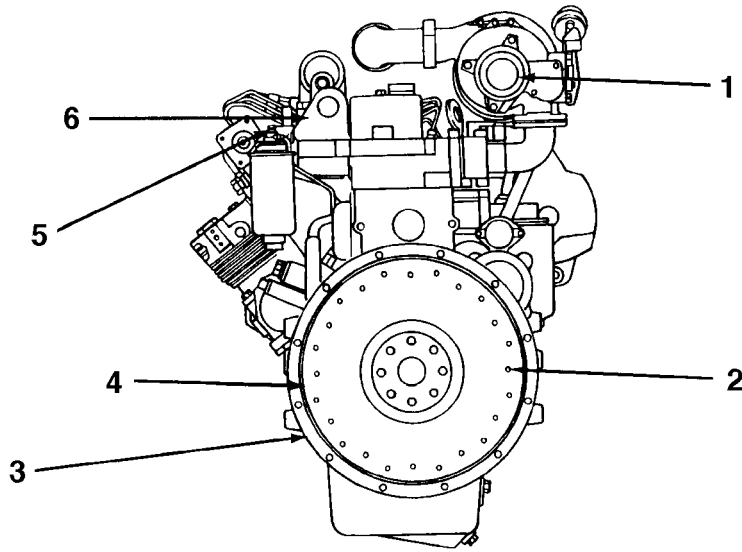

00900133

**Rear View**

- |                                |                                 |
|--------------------------------|---------------------------------|
| 1. Turbocharger exhaust outlet | 5. Fuel return connection       |
| 2. Flexplate mounting holes    | 6. Rear engine lifting bracket. |
| 3. Flywheel housing            |                                 |
| 4. Flywheel                    |                                 |

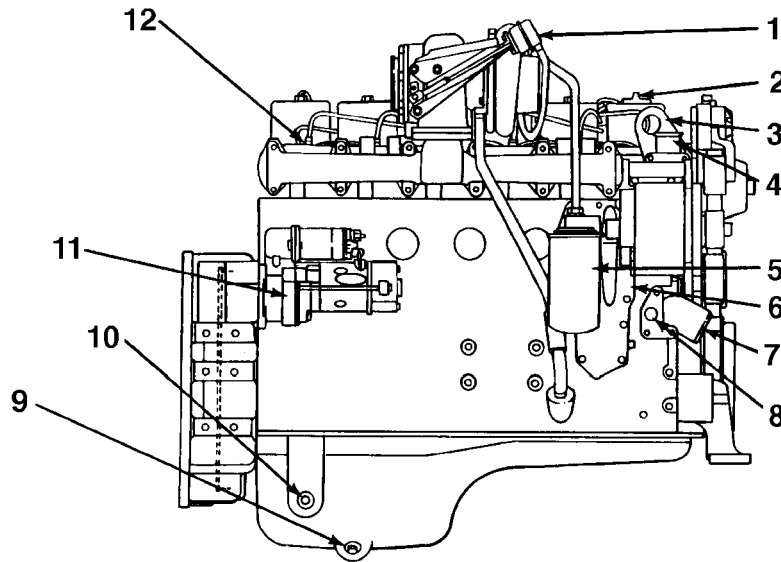

00900134

**Turbocharger Side View**

- |                                 |  |
|---------------------------------|--|
| 1. Turbocharger wastegate       | 7. Water inlet                         |
| 2. Oil fill cap                 | 8. 1/2-inch NPTF water heater return   |
| 3. Front engine lifting bracket | 9. Oil drain plug                      |
| 4. Water outlet                 | 10. Provision for oil immersion heater |
| 5. Lubricating oil filter       | 11. Starter motor and solenoid         |
| 6. Lubricating oil cooler       | 12. Fuel injection nozzles.            |

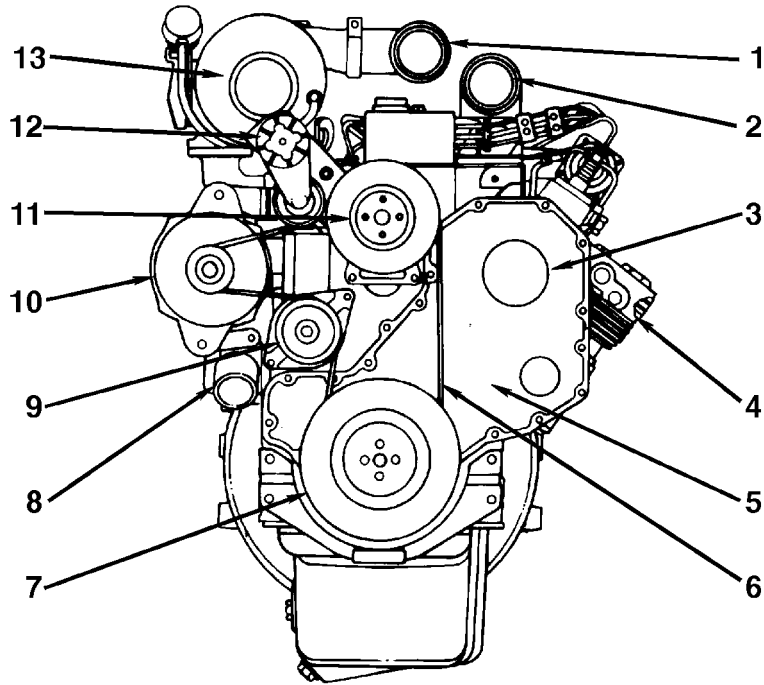

00900135

Front View

- |                              |                              |
|------------------------------|------------------------------|
| 1. Turbocharger air outlet   | 8. Water inlet               |
| 2. Engine air inlet          | 9. Water pump                |
| 3. Fuel pump drive cover     | 10. Alternator               |
| 4. Air compressor air outlet | 11. Fan pulley               |
| 5. Front gear cover          | 12. Automatic belt tensioner |
| 6. Fan drive belt            | 13. Turbocharger air inlet.  |
| 7. Vibration damper          |                              |



# Section TS - Troubleshooting Symptoms

## Section Contents

	Page
<b>Troubleshooting Procedures and Techniques</b> .....	TS-1
<b>Troubleshooting Symptoms Charts</b> .....	TS-2
Air Compressor Air Pressure Rises Slowly .....	TS-3
Air Compressor Cycles Frequently .....	TS-4
Air Compressor Noise is Excessive .....	TS-5
Air Compressor Pumping Excess Lubricating Oil into the Air System .....	TS-7
Air Compressor Will Not Maintain Adequate Air Pressure (Not Pumping Continuously).....	TS-9
Air Compressor Will Not Pump Air.....	TS-10
Air Compressor Will Not Stop Pumping .....	TS-11
Alternator Not Charging or Insufficient Charging .....	TS-12
Alternator Overcharging .....	TS-13
Coolant Contamination.....	TS-14
Coolant in the Lubricating Oil.....	TS-23
Coolant Loss.....	TS-15
Coolant Temperature Above Normal – Gradual Overheat.....	TS-17
Coolant Temperature is Above Normal – Sudden Overheat.....	TS-20
Coolant Temperature is Below Normal.....	TS-22
Crankcase Gases (Blowby) Excessive .....	TS-24
Engine Acceleration or Response Poor.....	TS-25
Engine Difficult to Start or Will Not Start (Exhaust Smoke) .....	TS-29
Engine Difficult to Start or Will Not Start (No Exhaust Smoke).....	TS-32
Engine Noise Excessive .....	TS-34
Engine Noise Excessive — Combustion Knocks.....	TS-37
Engine Noise Excessive — Connecting Rod .....	TS-38
Engine Noise Excessive — Main Bearing.....	TS-39
Engine Noise Excessive — Piston.....	TS-40
Engine Noise Excessive — Turbocharger .....	TS-41
Engine Power Output Low.....	TS-42
Engine Runs Rough at Idle .....	TS-46
Engine Runs Rough or Misfires.....	TS-48
Engine Speed Surges at Low or High Idle.....	TS-50
Engine Starts But Will Not Keep Running.....	TS-52
Engine Vibration Excessive .....	TS-54
Engine Will Not Crank or Cranks Slowly.....	TS-56
Engine Will Not Reach High Idle .....	TS-58
Engine Will Not Shut Off .....	TS-60
Excessive Noise .....	TS-61
Fuel Consumption Excessive.....	TS-62
Fuel in the Lubricating Oil .....	TS-65
Fuel Knock.....	TS-64
Fuel or Lubricating Oil Leaking From Exhaust Manifold.....	TS-66
Lubricating Oil Consumption Excessive.....	TS-67
Lubricating Oil Contaminated .....	TS-68
Lubricating Oil Pressure High.....	TS-69
Lubricating Oil Pressure Low.....	TS-70
Lubricating Oil Sludge in the Crankcase Excessive .....	TS-72
Lubricating Oil Temperature Above Specification .....	TS-73
Lubricating or Transmission Oil in the Coolant.....	TS-74
Smoke, Black — Excessive .....	TS-75
Smoke, White — Excessive .....	TS-77

**THIS PAGE LEFT INTENTIONALLY BLANK**

## Troubleshooting Procedures and Techniques

A thorough analysis of the customer's complaint is the key to successful troubleshooting. The more information known about a complaint, the faster and easier the problem can be solved.

The Troubleshooting Symptom Charts are organized so that a problem can be located and corrected by doing the easiest and most logical things first. Complete all steps in the sequence shown from top to bottom.

It is **not** possible to include all the solutions to problems that can occur; however, these charts are designed to stimulate a thought process that will lead to the cause and correction of the problem.

Follow these basic troubleshooting steps:

- Get all the facts concerning the complaint
- Analyze the problem thoroughly
- Relate the symptoms to the basic engine systems and components
- Consider any recent maintenance or repair action that can relate to the complaint
- Double-check before beginning any disassembly
- Solve the problem by using the symptom charts and doing the easiest things first
- Determine the cause of the problem and make a thorough repair
- After repairs have been made, operate the engine to make sure the cause of the complaint has been corrected

## Troubleshooting Symptoms Charts

Use the charts on the following pages of this section to aid in diagnosing specific engine symptoms. Read each row of blocks from top to bottom. Follow through the chart to identify the corrective action.



**Troubleshooting presents the risk of equipment damage, personal injury or death. Troubleshooting must be performed by trained experienced technicians.**

### Air Compressor Air Pressure Rises Slowly

This is symptom tree T004.

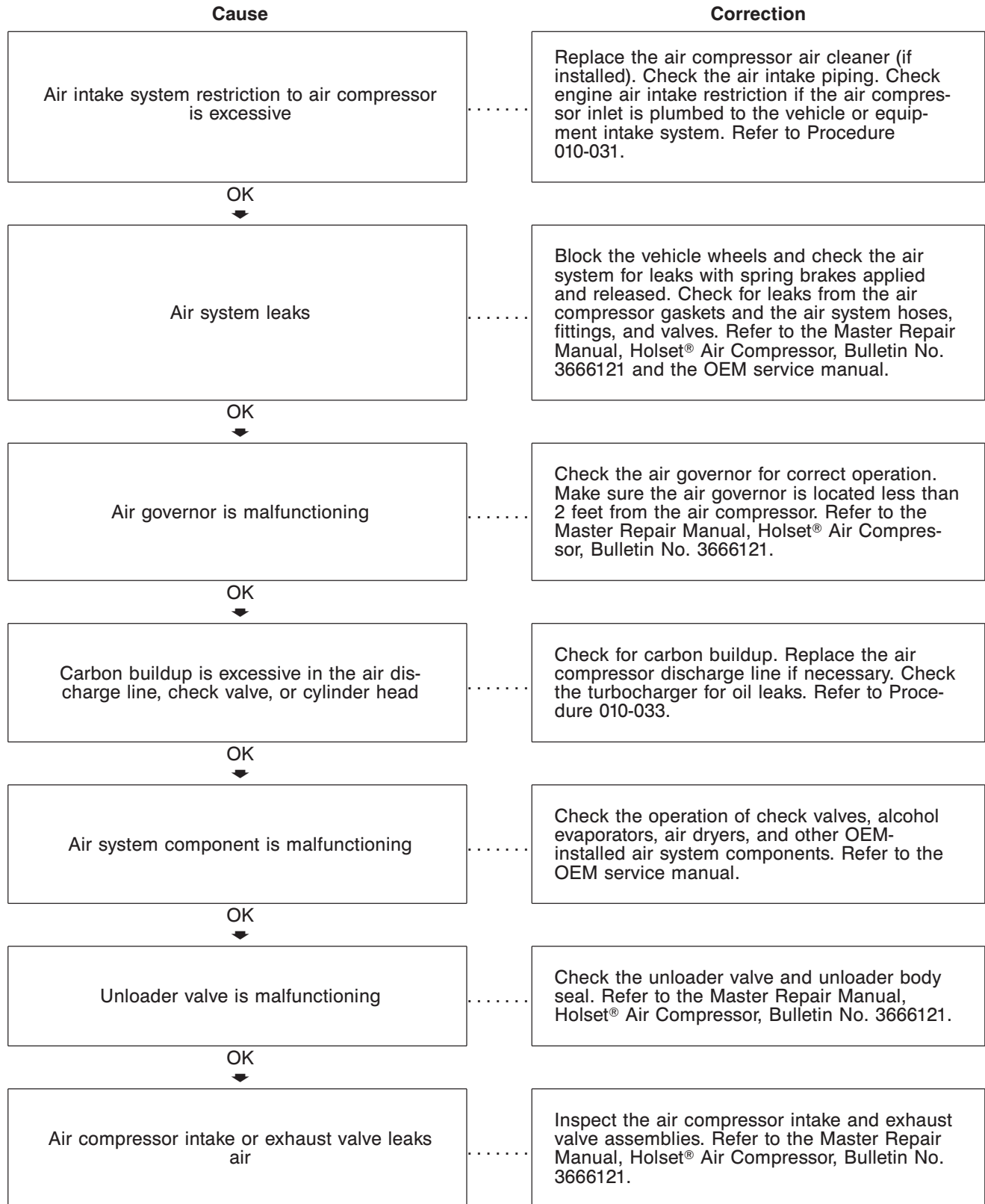

### Air Compressor Cycles Frequently

This is symptom tree T005.

**Cause**

**Correction**

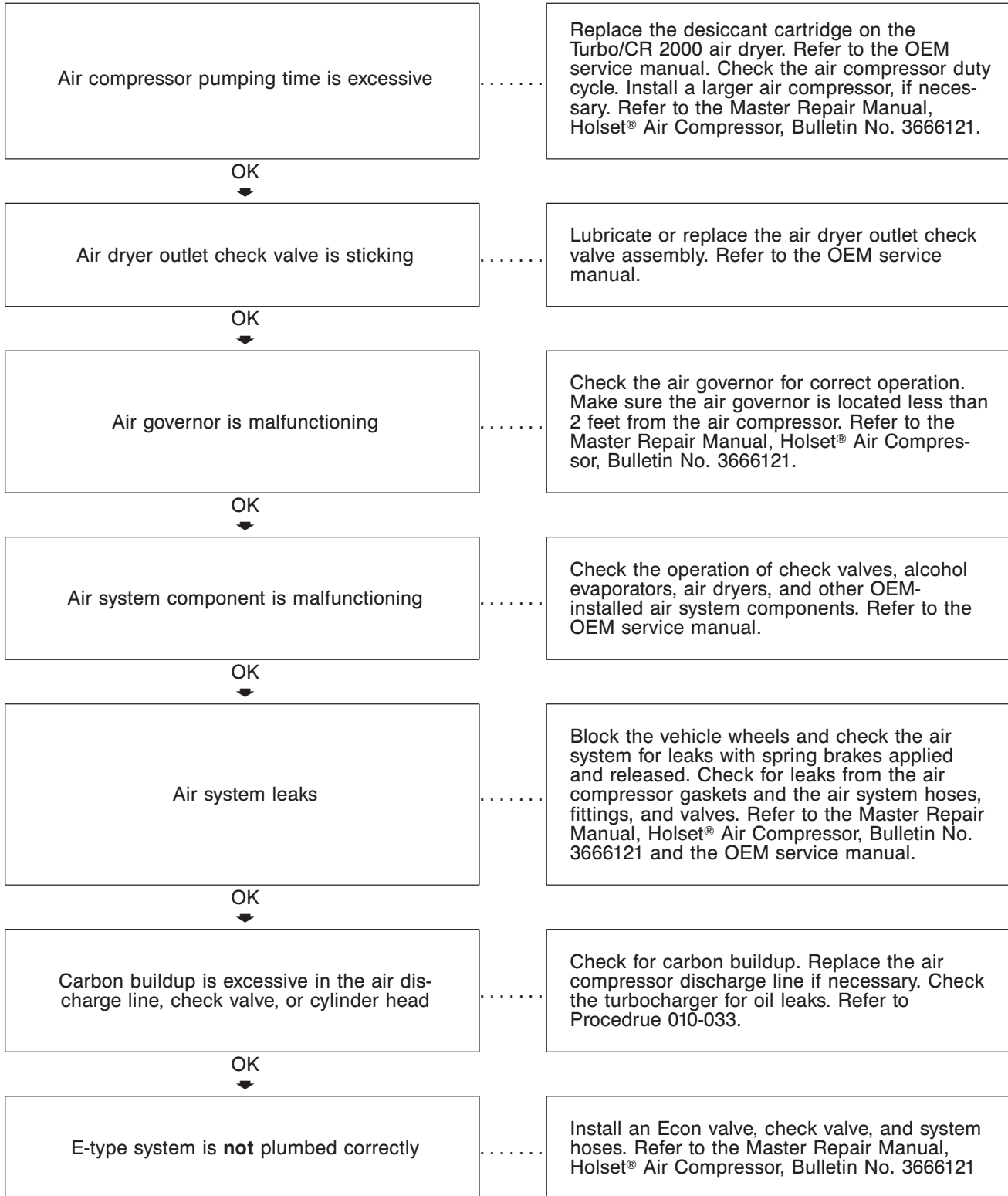

### Air Compressor Noise is Excessive

This is symptom tree T006.

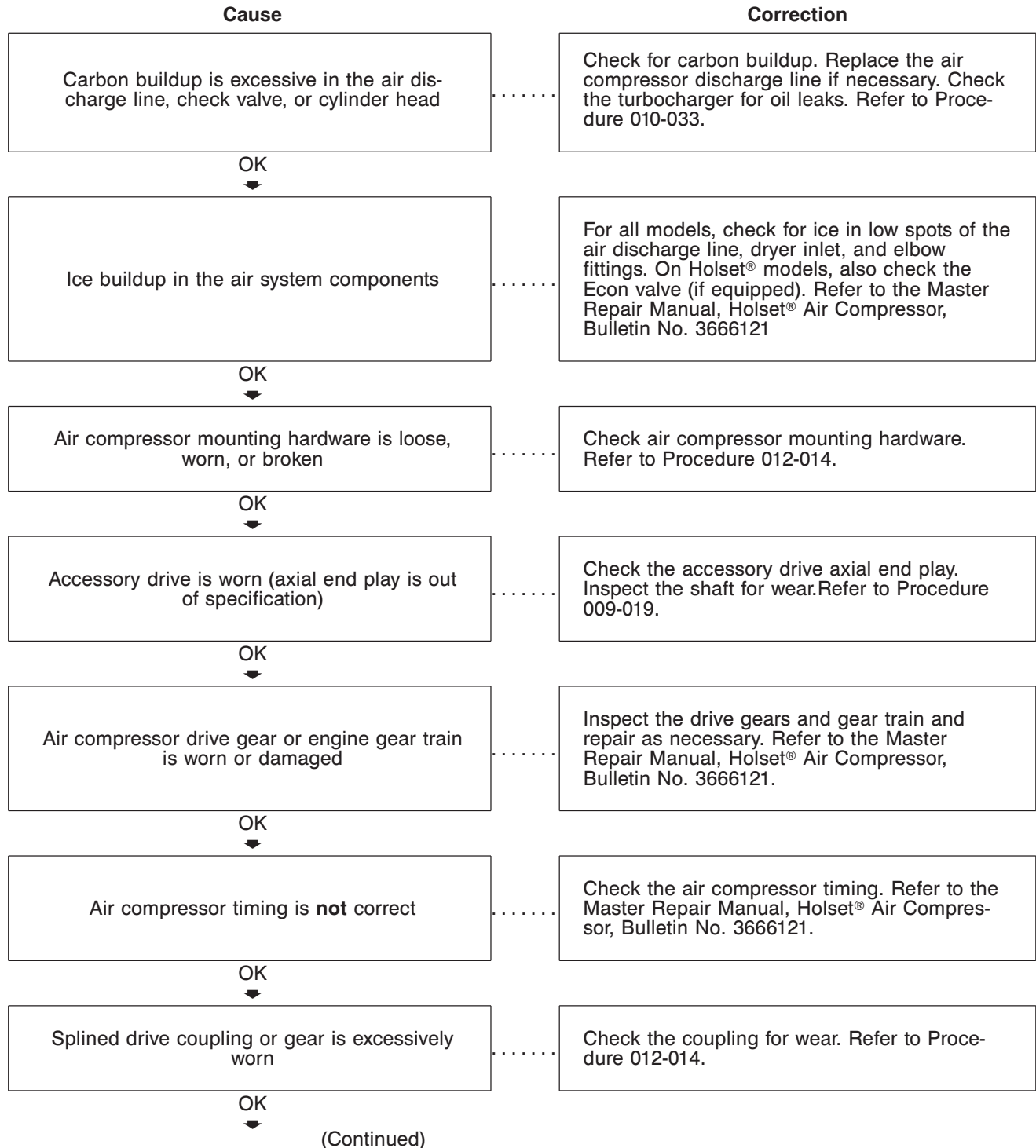

### Air Compressor Noise is Excessive (Continued)

**Cause**

**Correction**

Air compressor is excessively worn or internally damaged

Replace or rebuild the air compressor. Refer to the Master Repair Manual, Holset® Air Compressor, Bulletin No. 3666121. Replace the desiccant element on the Turbo/CR 2000 air dryer (if equipped). Refer to the manufacturer's instructions.

OK



Air compressor is sending air pulses into the air tanks

Install a ping tank between the air dryer and the wet tank and check discharge line size for the application. Refer to the manufacturer's instructions.



### Air Compressor Pumping Excess Lubricating Oil into the Air System

This is symptom tree T007.

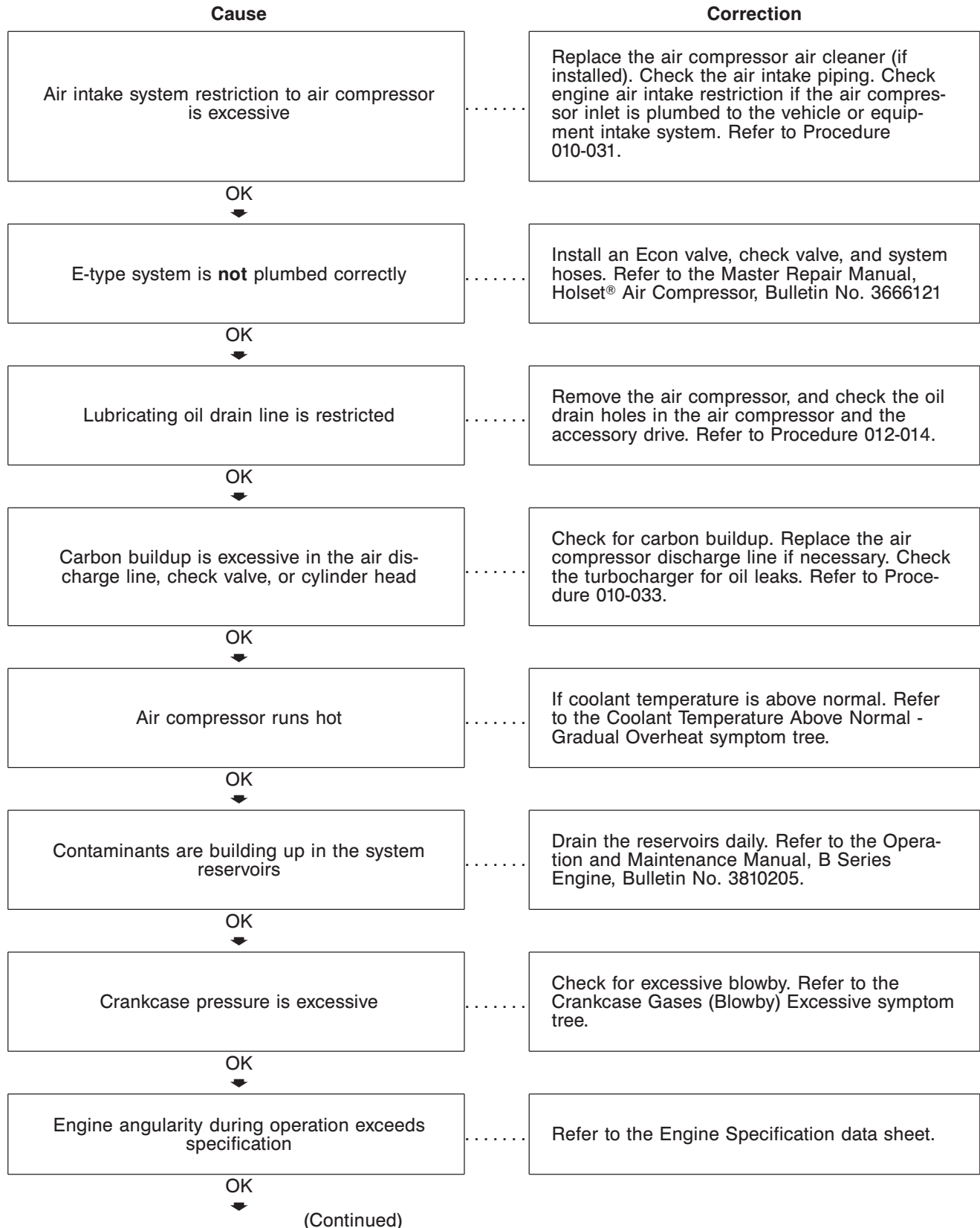

(Continued)

**Air Compressor Pumping Excess Lubricating Oil into the Air System (Continued)**

Cause	Correction
Lubricating oil pressure is above specification	Check the oil pressure. Refer to Procedure 007-052 or the OEM service manual.
OK ↓	
Air compressor drive gear or engine gear train is worn or damaged	Inspect the drive gears and gear train and repair as necessary. Refer to the Master Repair Manual, Holset® Air Compressor, Bulletin No. 3666121.
OK ↓	
Air compressor pumping time is excessive	Replace the desiccant cartridge on the Turbo/CR 2000 air dryer. Refer to the OEM service manual. Check the air compressor duty cycle. Install a larger air compressor, if necessary. Refer to the Master Repair Manual, Holset® Air Compressor, Bulletin No. 3666121.

### Air Compressor Will Not Maintain Adequate Air Pressure (Not Pumping Continuously)

This is symptom tree T008.

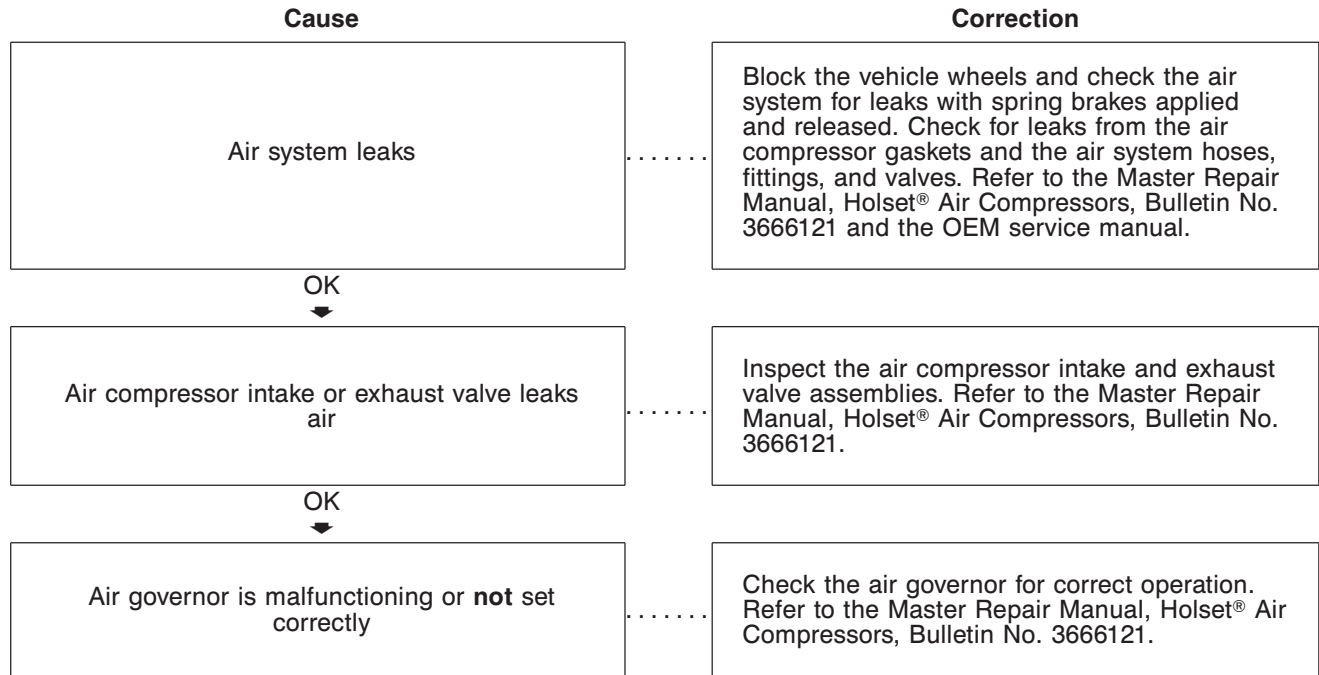

### Air Compressor Will Not Pump Air

This is symptom tree T009.

**Cause**

**Correction**

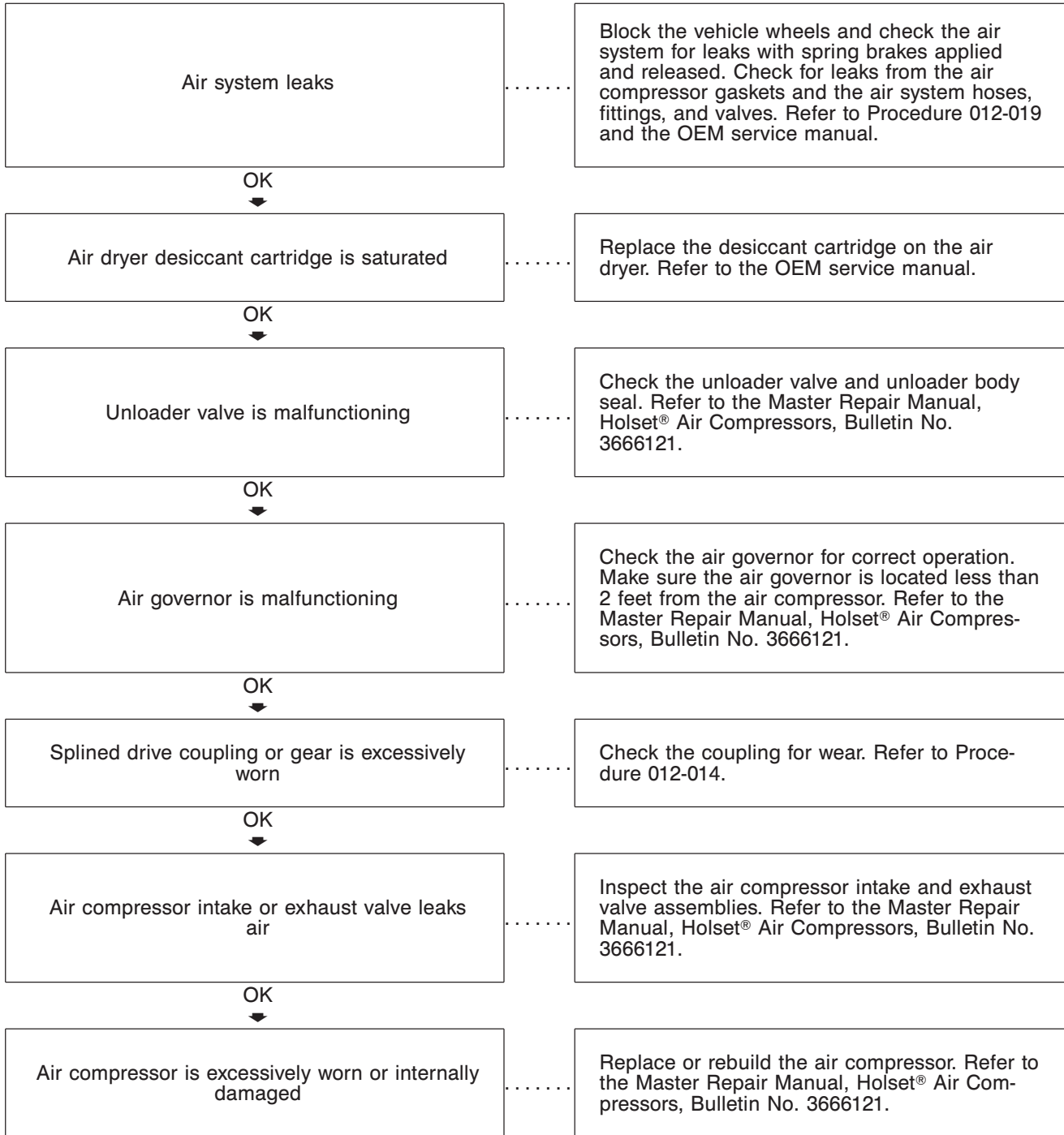

### Air Compressor Will Not Stop Pumping

This is symptom tree T010.

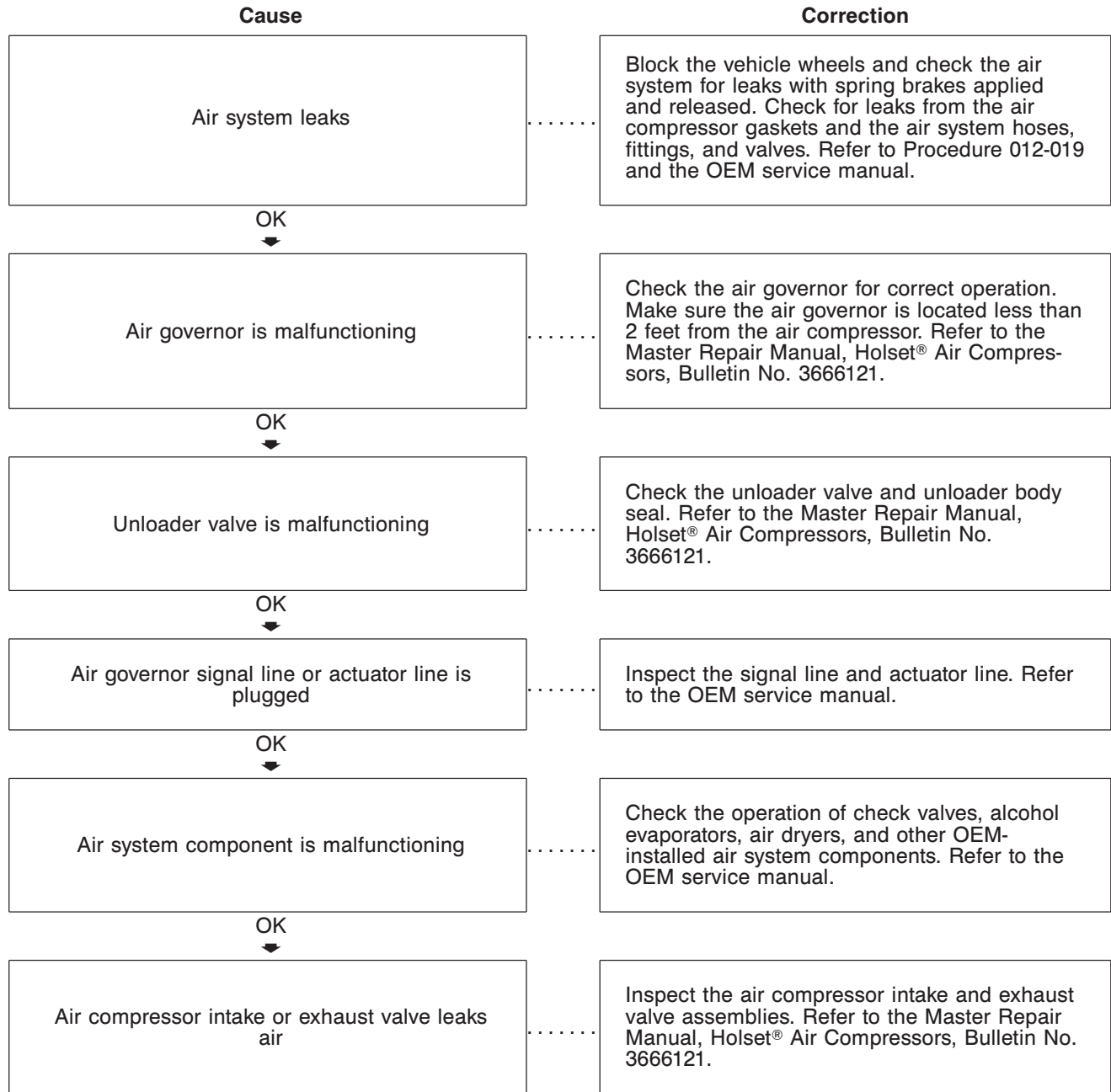

### Alternator Not Charging or Insufficient Charging

This is symptom tree T013.

**Cause**

**Correction**

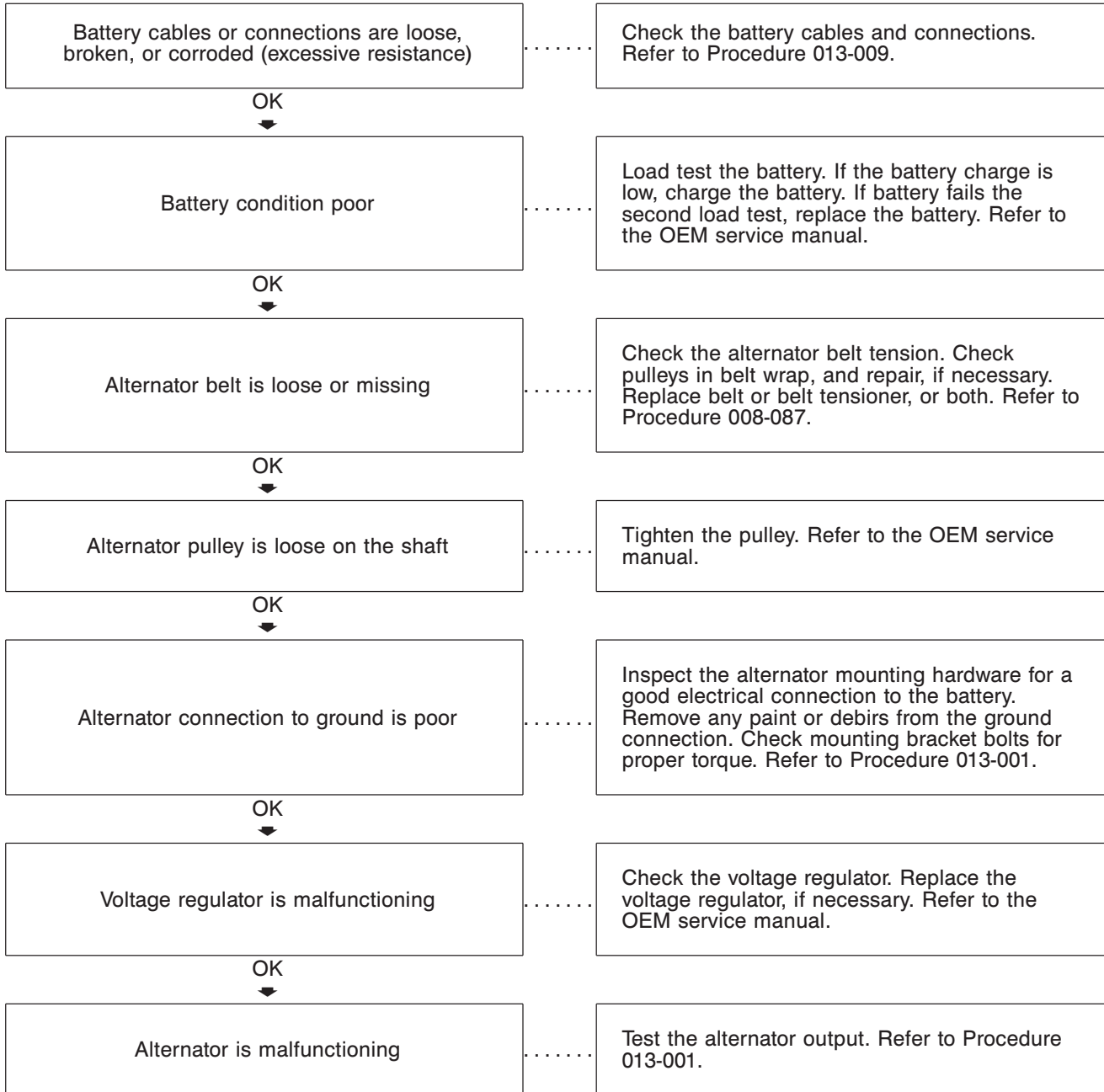

### Alternator Overcharging

This is symptom tree T014.

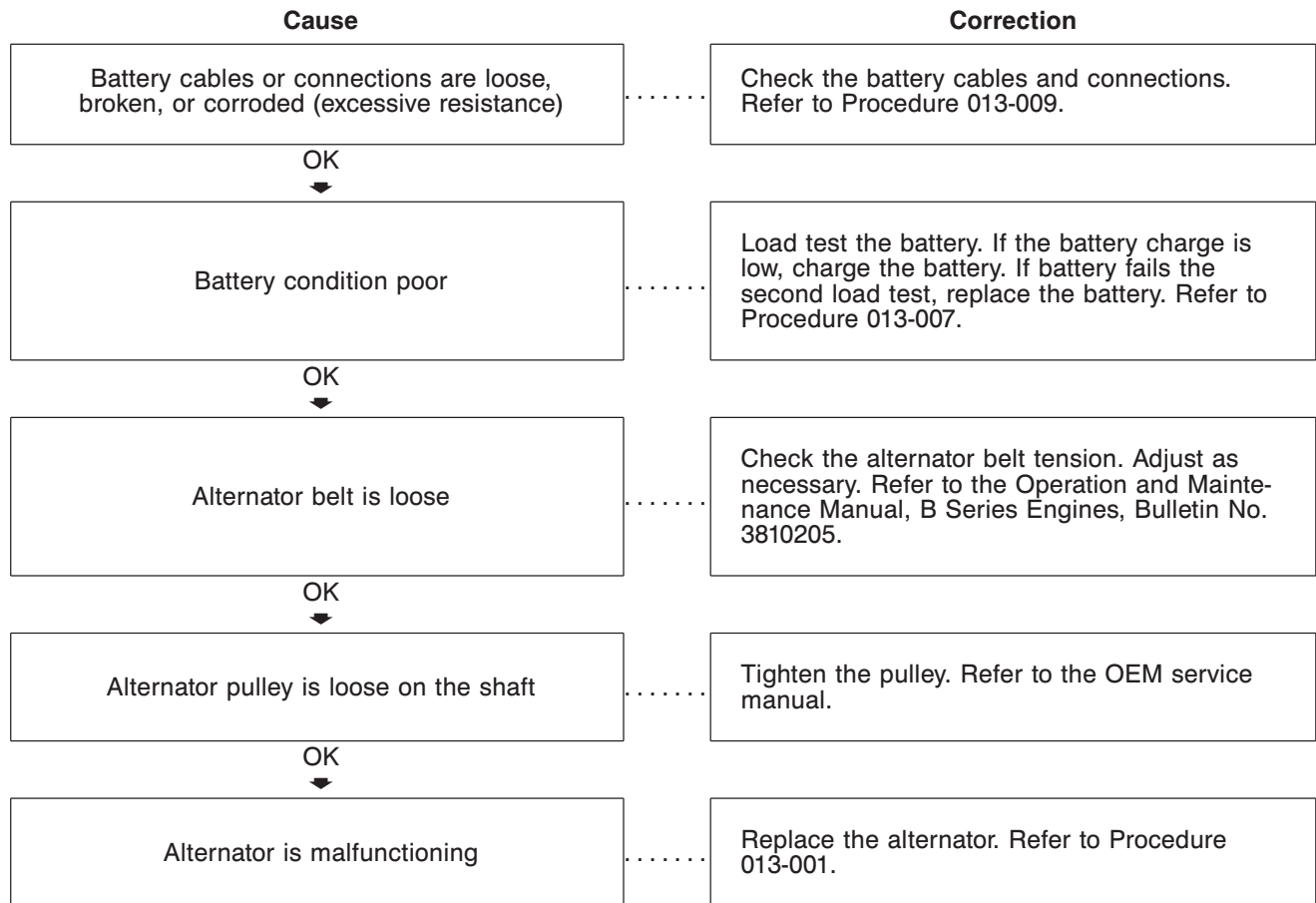

### Coolant Contamination

This is symptom tree T018.

**Cause**

**Correction**

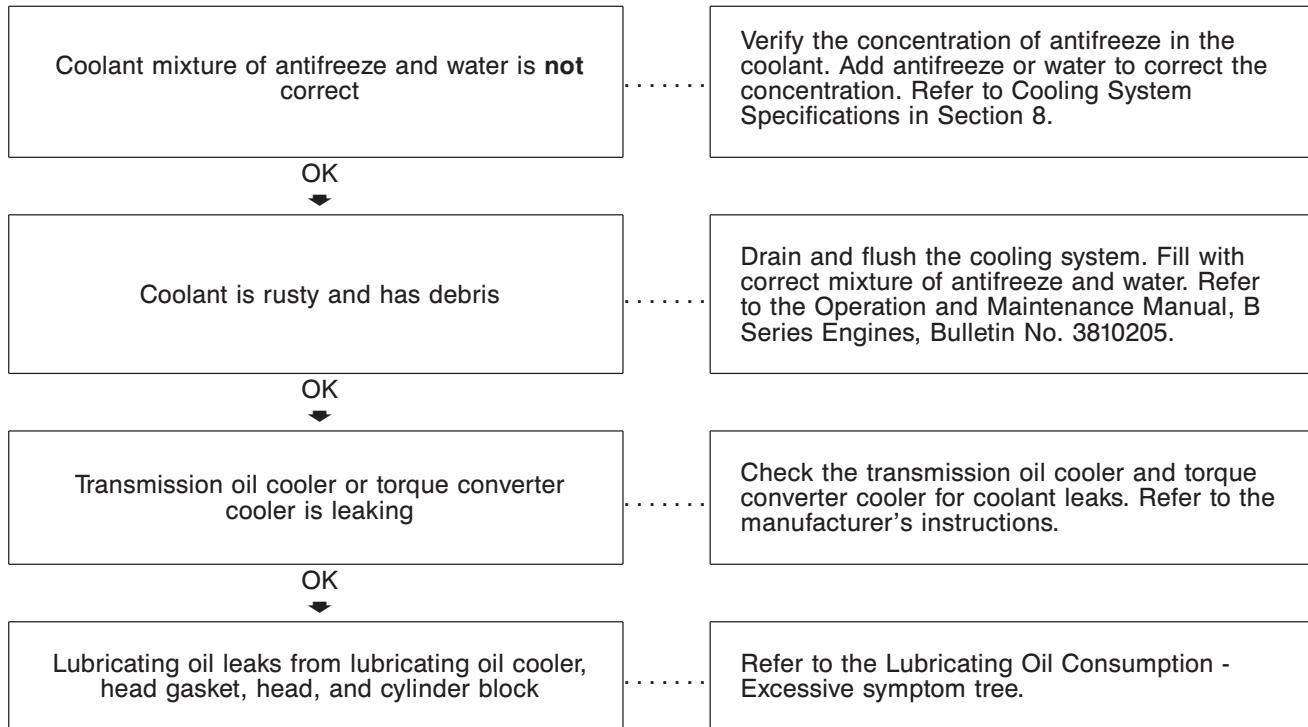



### Coolant Loss

This is symptom tree T019.

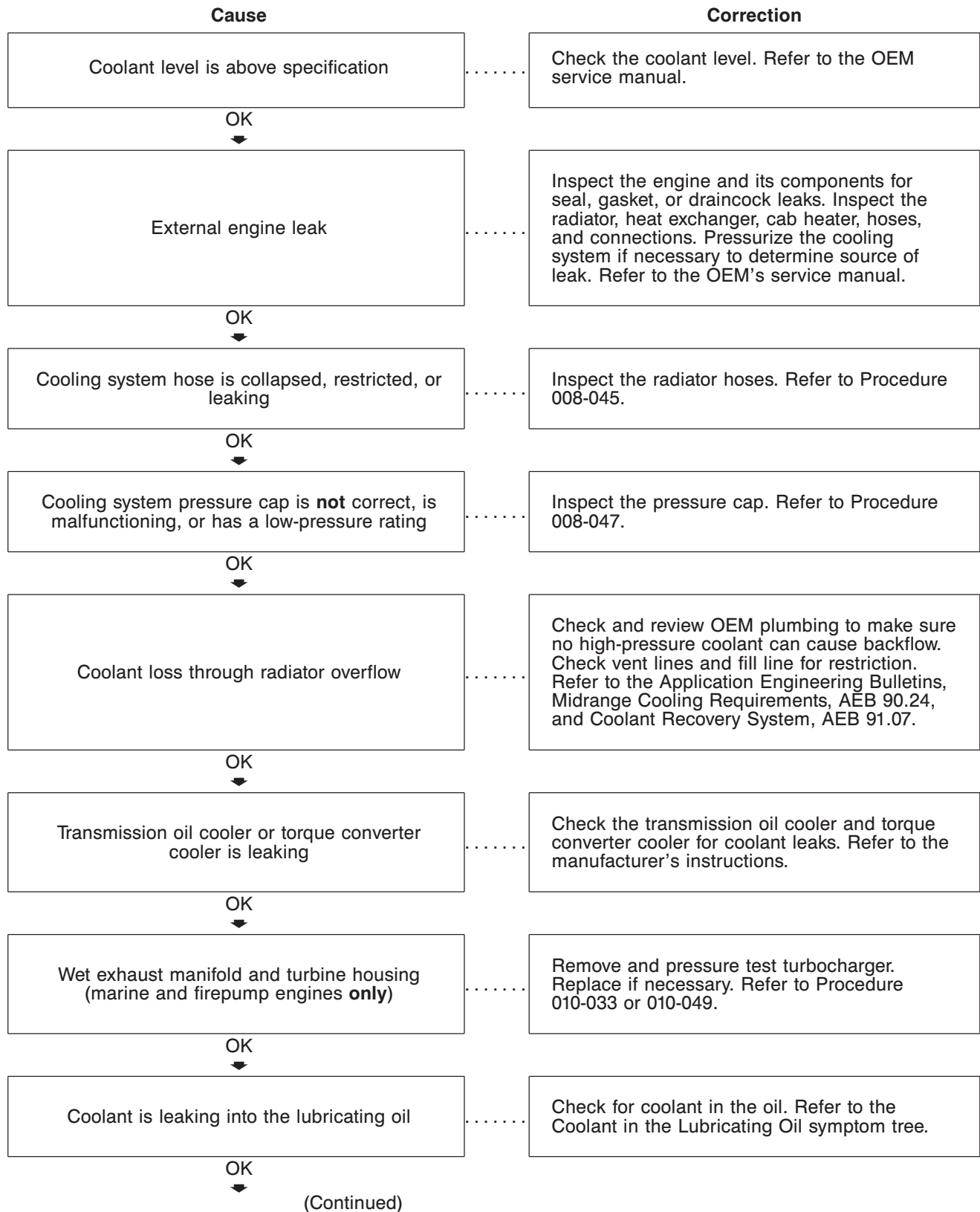

**Coolant Loss (Continued)**

**Cause**

**Correction**

Coolant is leaking into the combustion chamber

Remove the cylinder head, and inspect cylinder head, gasket, pistons for evidence of coolant. Refer to Procedure 002-004, 002-021, or 001-043.

**Coolant Temperature Above Normal – Gradual Overheat**

This is symptom tree T022.

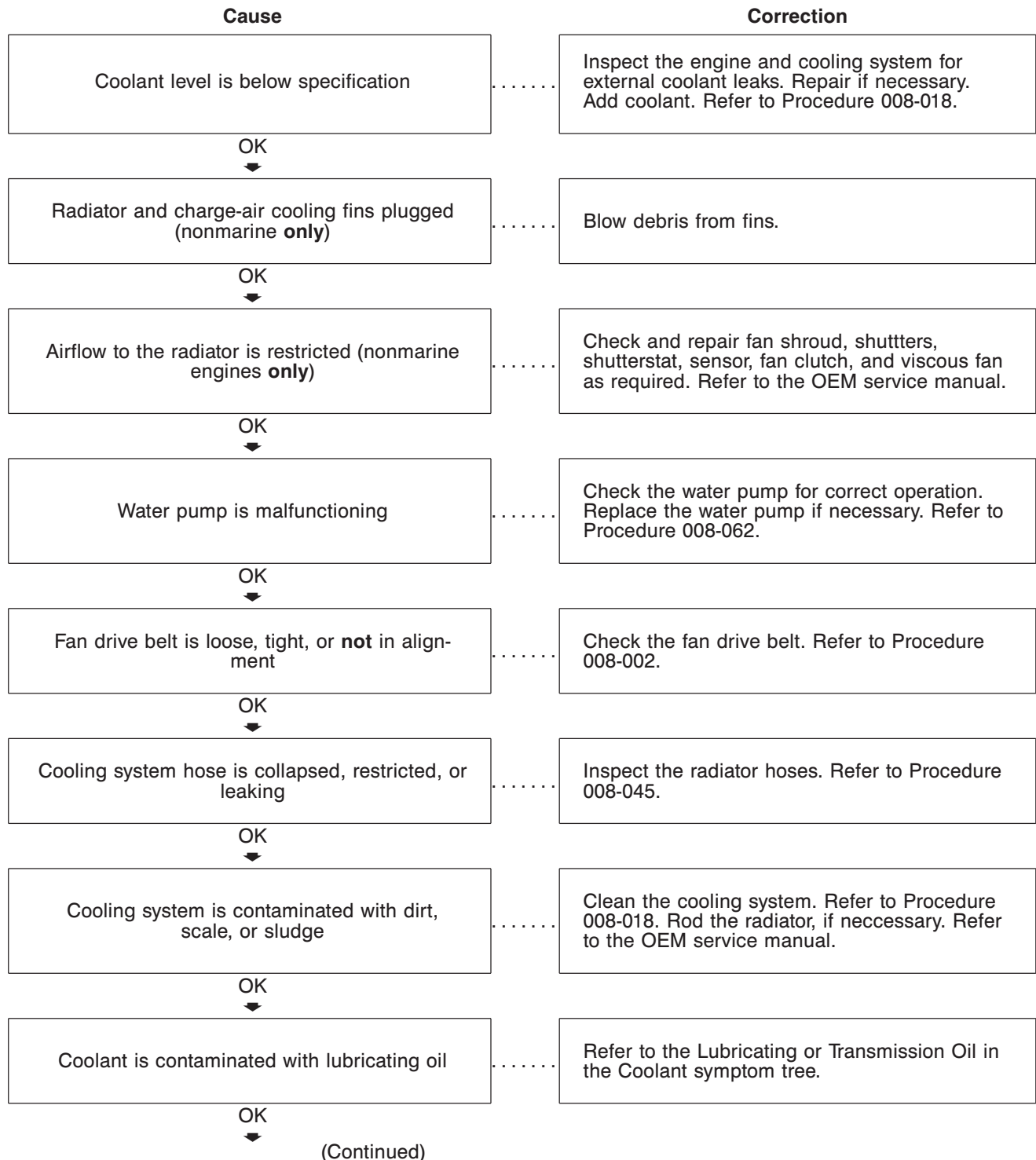

**Coolant Temperature Above Normal – Gradual Overheat (Continued)**

**Cause**

**Correction**

<p>Fan shroud is damaged or missing, or the air recirculation baffles are damaged or missing</p>	<p>Inspect the shroud and the recirculation baffles. Repair, replace, or install, if necessary. Refer to Procedure 008-038 and the OEM service manual.</p>
<p>OK ↓</p>	
<p>Cooling system pressure cap is <b>not</b> correct, is malfunctioning, or has a low-pressure rating</p>	<p>Inspect the pressure cap. Refer to Procedure 008-047.</p>
<p>OK ↓</p>	
<p>Coolant mixture of antifreeze and water is <b>not</b> correct</p>	<p>Verify the concentration of antifreeze in the coolant. Add antifreeze or water to correct the concentration. Refer to Cooling System Specifications in Section 8.</p>
<p>OK ↓</p>	
<p>Temperature gauge malfunction</p>	<p>Check or replace the temperature gauge. Refer to the OEM service manual.</p>
<p>OK ↓</p>	
<p>Thermostat is <b>not</b> correct or is malfunctioning</p>	<p>Check the thermostat for the correct part number and for correct operation. Refer to Procedure 008-013. Make sure thermostat is vented properly. Refer to Application Engineering Bulletin, AEB 90.24.</p>
<p>OK ↓</p>	
<p>Air or combustion gases are entering the cooling system</p>	<p>Check for air or combustion gases in the cooling system. Refer to Procedure 008-019. Check fill rate to see if it not being exceeded.</p>
<p>OK ↓</p>	
<p>Sea water pump is malfunctioning (marine engines <b>only</b>)</p>	<p>Check for inlet restriction or aeration. Check system discharge or outlet pressure. Check the sea water pump impeller for damage. Refer to Procedure 008-057.</p>
<p>OK ↓</p>	
<p>Plugged or restricted heat exchanger (marine engines <b>only</b>)</p>	<p>Clean the heat exchanger, both sea water and coolant passages. Refer to Procedure 008-053.</p>

OK  
↓

(Continued)

**Coolant Temperature Above Normal – Gradual Overheat (Continued)**

Cause	Correction
Keel cooler is malfunctioning (marine engines <b>only</b> )	Inspect the keel cooler for proper operation. Refer to the vessel OEM service manual.
OK ↓	
Fuel injection pump timing is <b>not</b> correct	Put the engine at top dead center. Check and adjust the fuel timing. Refer to Procedure 005-037.
OK ↓	
Fuel injection pump is malfunctioning	Replace the fuel injection pump. Refer to Procedure 005-012 or 005-014.
OK ↓	
Plugged cooling passages in the cylinder head, head gasket, or cylinder block	Pressure test the cooling system. Refer to Procedure 008-020.
OK ↓	
Cooling system has insufficient capacity	Refer to the Application Engineering Bulletin (AEB) 90.24 for cooling system specifications.

### Coolant Temperature is Above Normal – Sudden Overheat

This is symptom tree T023.

**Cause**

**Correction**

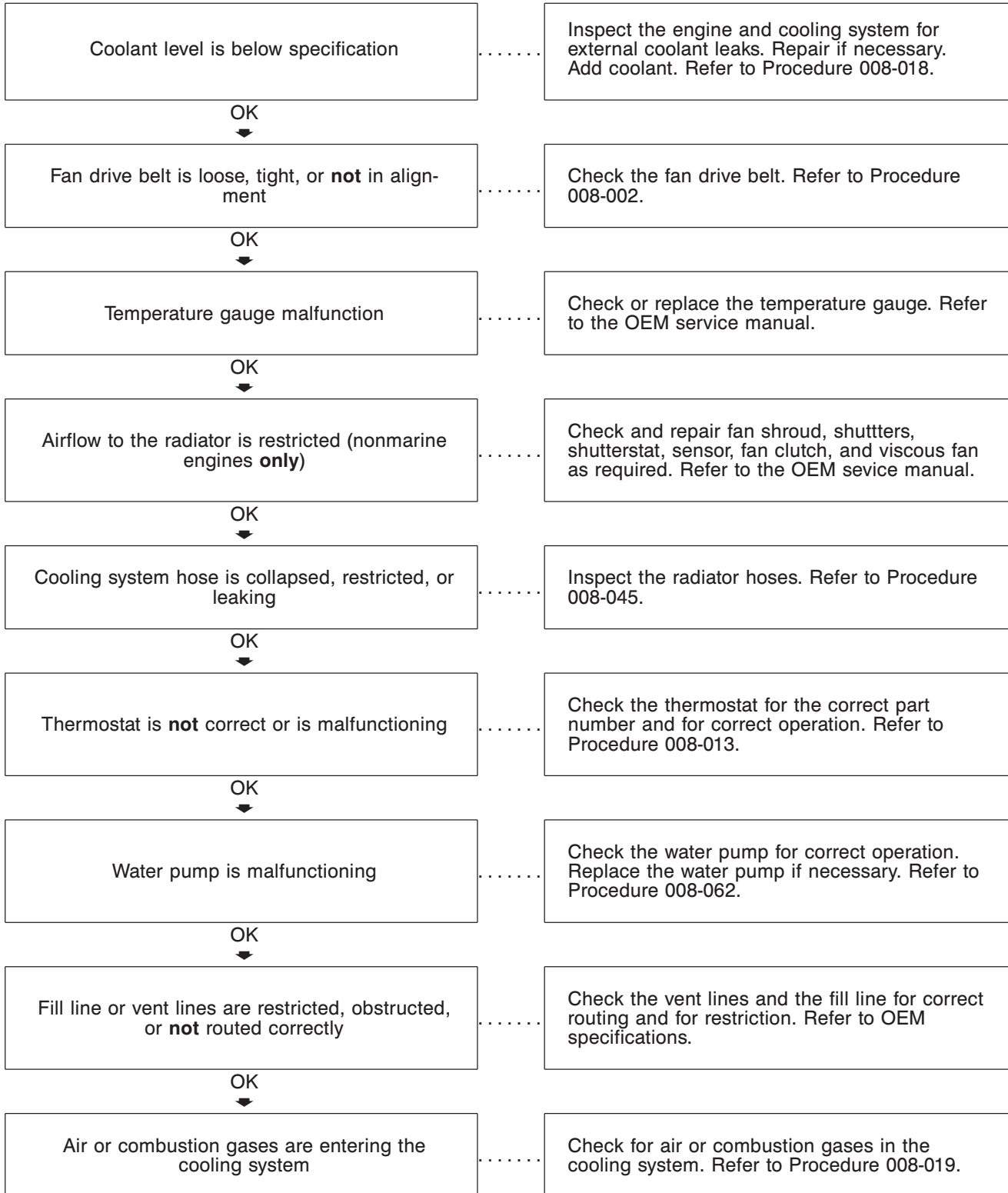

OK  
↓

(Continued)

### Coolant Temperature is Above Normal – Sudden Overheat (Continued)

Cause	Correction
Plugged cooling passages in the cylinder head, head gasket, or cylinder block	Pressure test the cooling system. Refer to Procedure 002-004.
OK ▼	
Cooling system has insufficient capacity	Refer to AEB 90.24 for the cooling system specifications.

### Coolant Temperature is Below Normal

This is symptom tree T024.

**Cause**

**Correction**

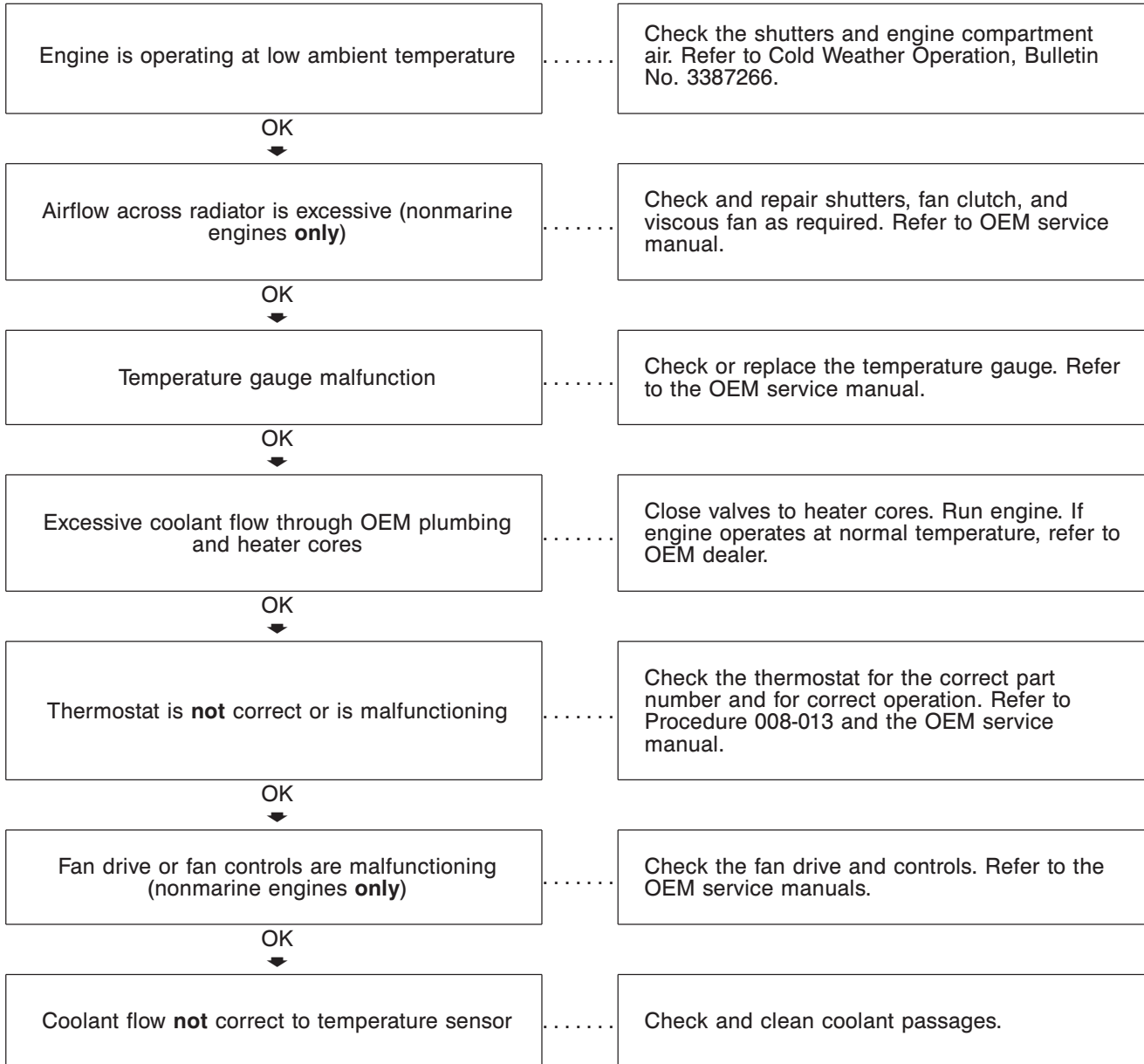



### Coolant in the Lubricating Oil

This is symptom tree T025.

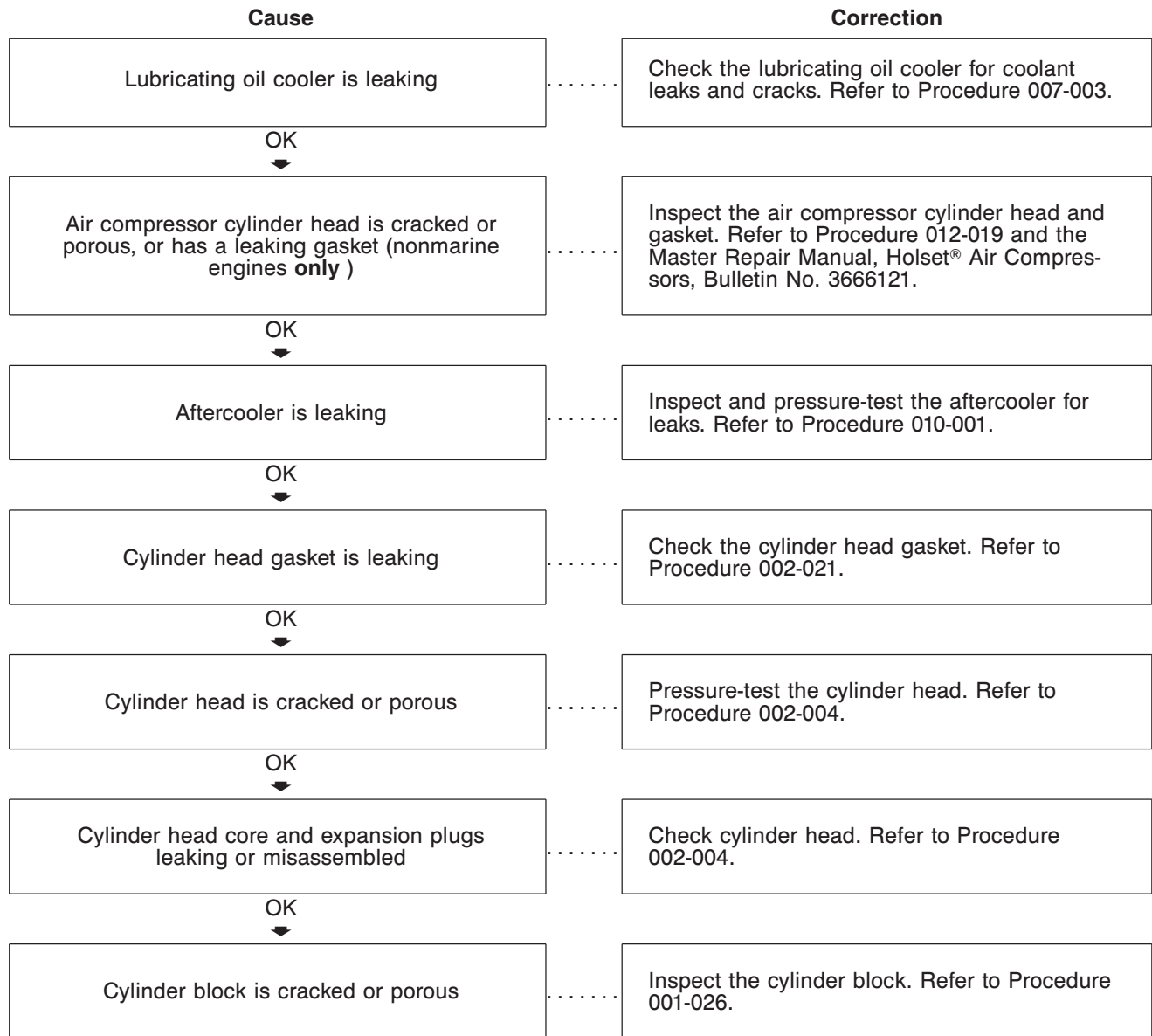

### Crankcase Gases (Blowby) Excessive

This is symptom tree T027.

**Cause**

**Correction**

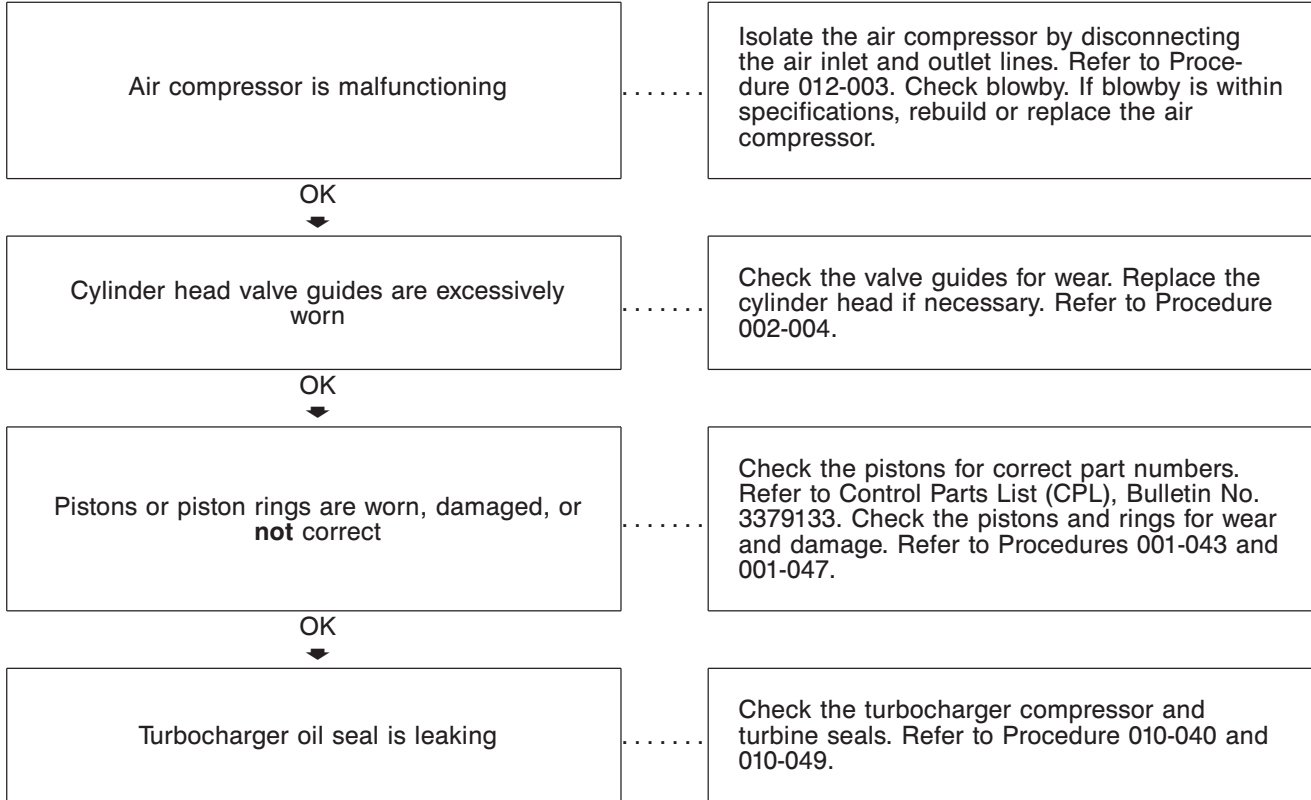

### Engine Acceleration or Response Poor

This is symptom tree T033.

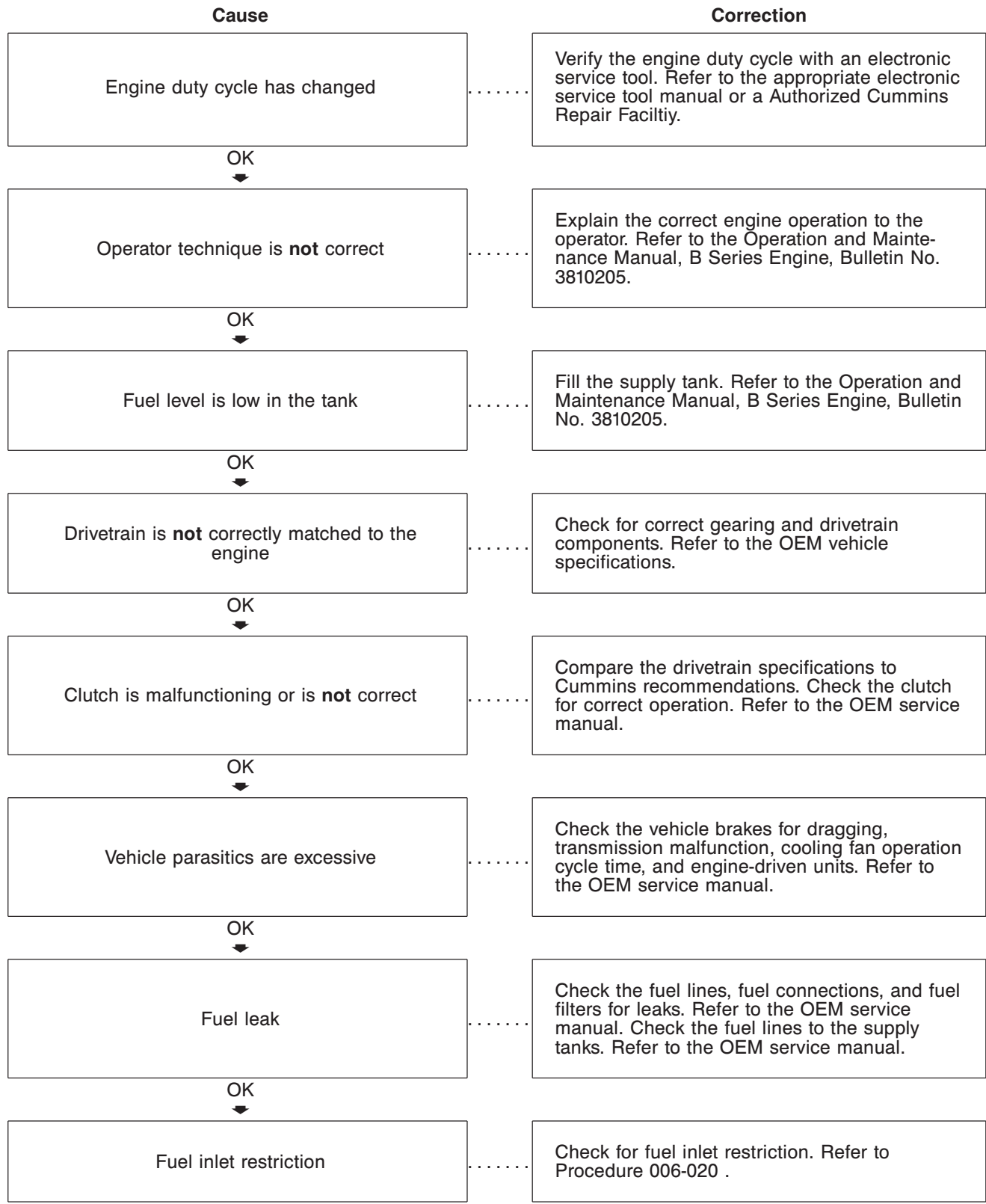

OK  
↓  
(Continued)

Engine Acceleration or Response Poor (Continued)

Cause

Correction

<p>Fuel lift pump is malfunctioning</p>	<p>Check the fuel lift pump for correct operation. Check the pump output pressure. Replace the fuel lift pump if necessary. Refer to Procedure 005-045.</p>
<p>OK ↓</p>	
<p>Fuel pump overflow valve is malfunctioning</p>	<p>Check the overflow valve. Refer to Procedure 006-044.</p>
<p>OK ↓</p>	
<p>Air in the fuel system</p>	<p>Check for air in the fuel system. Repair source of leak and bleed air from the system. Refer to Procedure 006-003.</p>
<p>OK ↓</p>	
<p>Air intake system restriction is above specification</p>	<p>Check the air intake system for restriction. Clean or replace the air filter and inlet piping as necessary. Refer to Procedure 010-031.</p>
<p>OK ↓</p>	
<p>Charge-air cooler (CAC) is restricted or leaking</p>	<p>Inspect the CAC for air restrictions or leaks. Refer to Procedure 010-027.</p>
<p>OK ↓</p>	
<p>Air intake or exhaust leaks</p>	<p>Inspect the air intake and exhaust systems for air leaks. Refer to Procedure 010-024.</p>
<p>OK ↓</p>	
<p>Turbocharger is <b>not</b> correct</p>	<p>Check the turbocharger part number and compare it to the Control Parts List (CPL), Bulletin No. 3379133. Replace the turbocharger if necessary. Refer to Procedure 010-033.</p>
<p>OK ↓</p>	
<p>Turbocharger wastegate is malfunctioning (if equipped)</p>	<p>Check the wastegate for correct operation. Refer to Procedure 010-050.</p>

OK



(Continued)

**Engine Acceleration or Response Poor (Continued)**

Cause	Correction
Exhaust brake adjustment is <b>not</b> correct	Check the exhaust brake adjustment. Refer to the OEM service manual.
OK ↓	
Exhaust system restriction is above specification	Check the exhaust system for restrictions. Refer to Procedure 011-009.
OK ↓	
Overhead adjustments are <b>not</b> correct	Measure and adjust the overhead settings. Refer to Procedure 003-004.
OK ↓	
Injectors are <b>not</b> correct	Remove the injectors and compare the part numbers to the Control Parts List (CPL), Bulletin No. 3379133. Replace the injectors if necessary. Refer to Procedure 006-026.
OK ↓	
Injector is malfunctioning	Perform a pot test on the injector(s). Refer to Procedure 006-026.
OK ↓	
Fuel grade is <b>not</b> correct for the application, or the fuel quality is poor	Operate the engine from a tank of high-quality fuel. Refer to the Operation and Maintenance Manual, B Series Engines, Bulletin No. 3810205.
OK ↓	
Fuel inlet temperature to pump is above specification	Fill the fuel tank, turn off or bypass the fuel heaters, and check the fuel cooler. Refer to the OEM service manual.
OK ↓	
Fuel supply line restriction between the fuel pump and the injectors	Check the fuel supply line from the fuel pump to the cylinder head for sharp bends that can cause restrictions. Refer to Procedure 006-051.
OK ↓	
(Continued)	

**Engine Acceleration or Response Poor (Continued)**

**Cause**

**Correction**

Internal engine damage

.....

Analyze the oil and inspect the filters to locate an area of probable damage. Refer to Procedure 007-013.

**Engine Difficult to Start or Will Not Start (Exhaust Smoke)**

This is symptom tree T043.

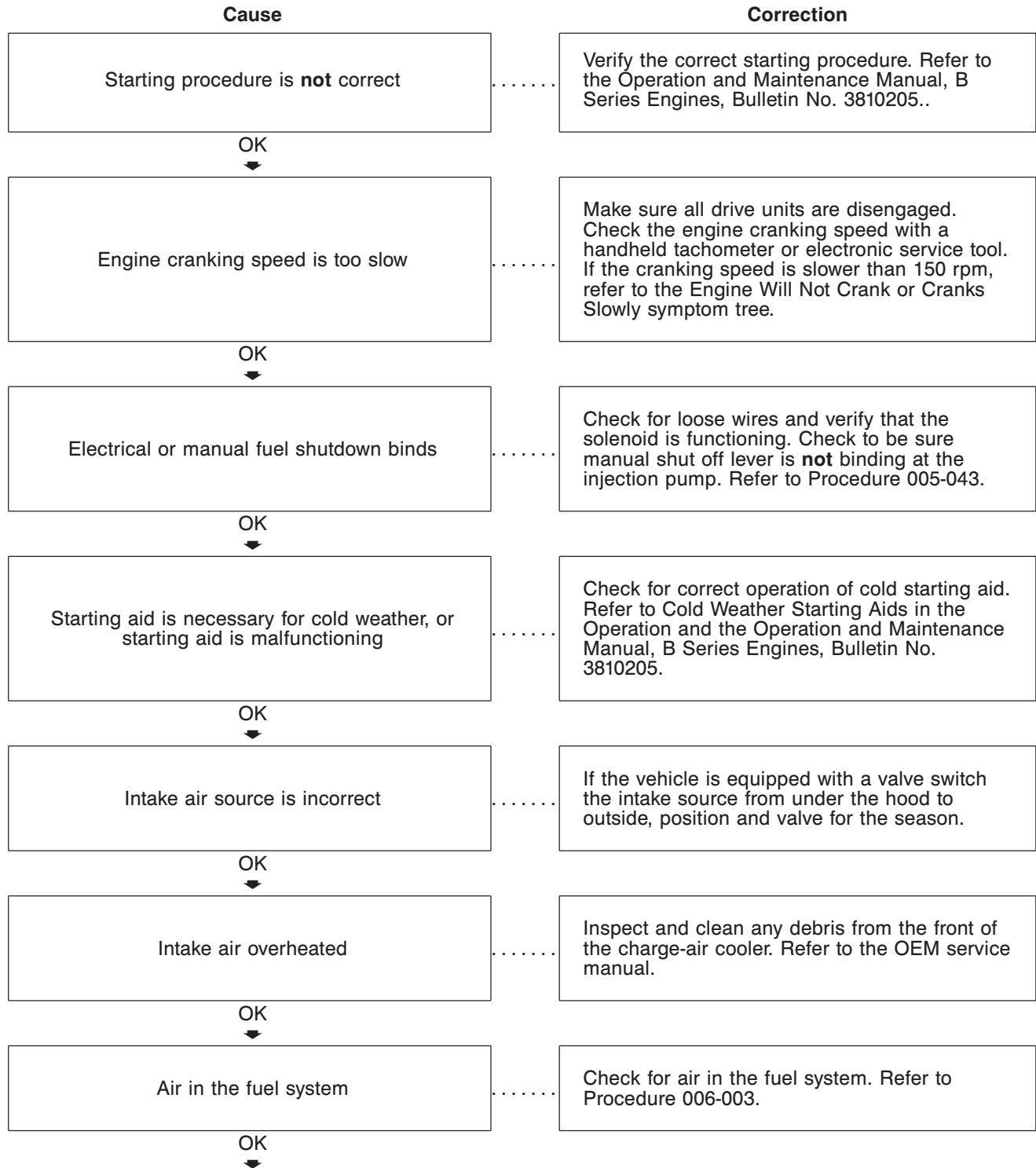

(Continued)

Engine Difficult to Start or Will Not Start (Exhaust Smoke) (Continued)

Cause

Correction

Fuel filter or fuel inlet restriction

Check the flow through the fuel filter. Replace the fuel filter if necessary. Refer to Procedure 006-015. Clean all prefilters and screens. Check the fuel suction line for restriction.

OK



Fuel quality is poor or diesel fuel grade No. 1 is used above 0°C [32°F]

No. 1 diesel fuel and other light winter fuels are lower in heat content than No. 2 diesel fuel and result in higher fuel consumption. Evaluate fuel consumption using No. 2 diesel fuel. Fuel additives also result in lower heat content. Refer to the Fuel Recommendations/ Specifications in the Operation and Maintenance Manual, B Series Engines, Bulletin No. 3810205.

OK



Fuel pump return overflow valve is malfunctioning

Inspect the return overflow valve. Replace if necessary. Refer to Procedure 006-044.

OK



Fuel return line improperly plumbed

Make sure the fuel return line is plumbed to the bottom of the fuel tank.

OK



Fuel transfer pump malfunctioning

Inspect the fuel transfer pump. Replace if necessary. Refer to Procedure 005-045.

OK



Fuel injection pump timing is **not** correct

Put the engine at top dead center. Check and adjust the fuel timing. Refer to Procedure 005-014.

OK



Charge-air cooler restricted (if equipped)

Inspect the air cooler for internal and external restriction. Replace the restricted cooler if necessary. Refer to Procedure 010-027.

OK



Valves are **not** sealing correctly

Check and adjust the valves. Refer to Procedure 002-020.

OK



(Continued)



### Engine Difficult to Start or Will Not Start (Exhaust Smoke) (Continued)

Cause	Correction
Injectors worn or malfunctioning	Remove and test the injectors. Replace as necessary. Refer to Procedure 006-026.
OK ↓	
Engine compression is low	Perform the compression check to identify the malfunction. Correct as required. Refer to Procedure 014-008.
OK ↓	
Fuel injection pump is malfunctioning	Remove the fuel pump. Refer to Procedure 005-012 or 005-014. Calibrate the fuel pump.

**Engine Difficult to Start or Will Not Start (No Exhaust Smoke)**

This is symptom tree T044.

**Cause**

**Correction**

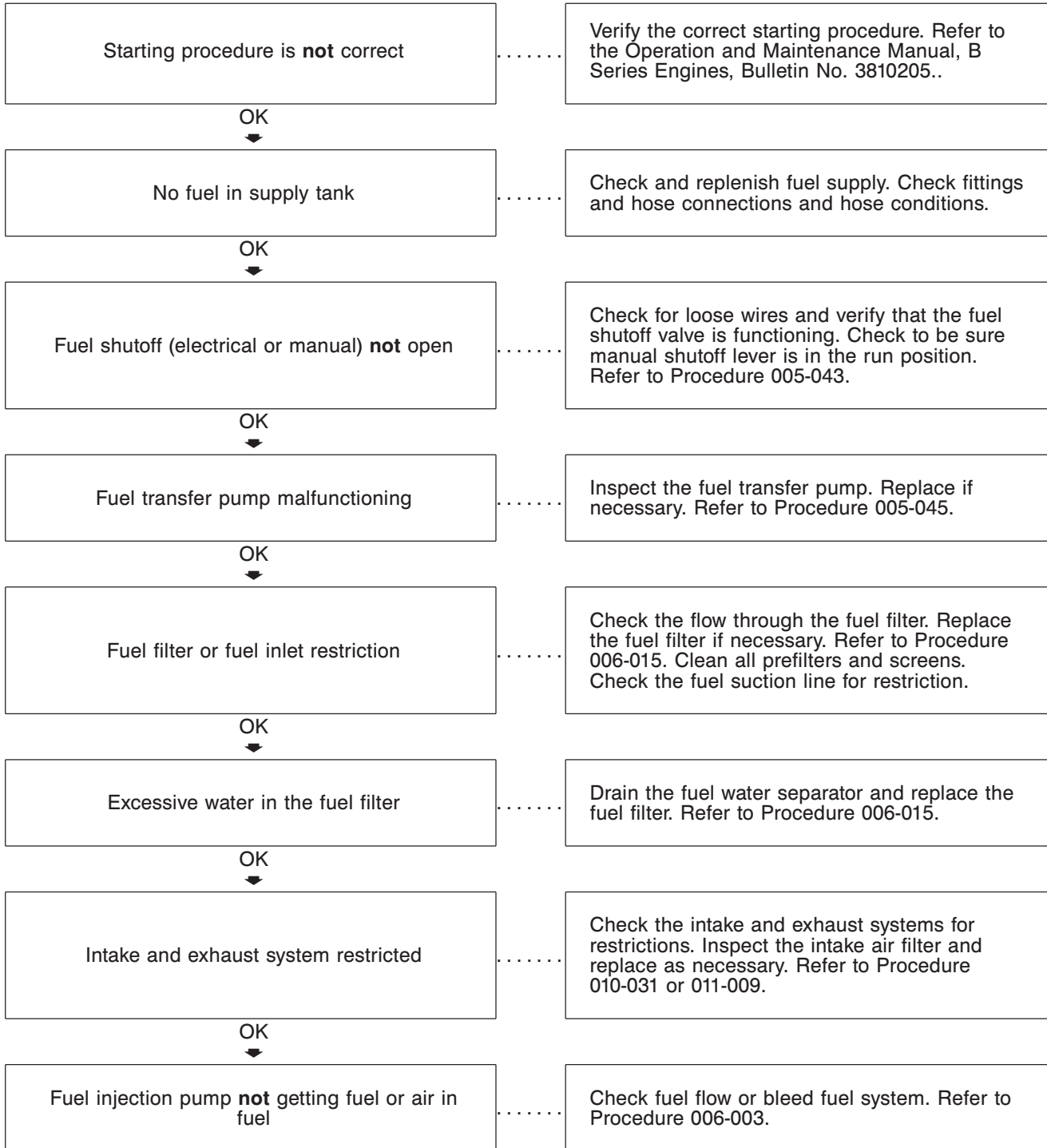

OK



(Continued)

**Engine Difficult to Start or Will Not Start (No Exhaust Smoke) (Continued)**

Cause	Correction
Fuel return restriction excessive	Inspect the fuel return lines for restrictions. Refer to Procedure 006-012.
OK ↓	
Fuel pump return overflow valve is malfunctioning	Inspect the return overflow valve. Replace if necessary. Refer to Procedure 006-044.
OK ↓	
Fuel injection pump timing is <b>not</b> correct	Put the engine at top dead center. Check and adjust the fuel timing. Refer to Procedure 005-013, 005-014, or 005-037.
OK ↓	
Fuel injection pump is malfunctioning	Remove the fuel injection pump. Check the calibration of the fuel injection pump. Refer to Procedure 005-012 or 005-014.
OK ↓	
Camshaft timing is <b>not</b> correct (after engine rebuild or repair)	Check the gear train timing alignment. Refer to Procedure 001-008.

### Engine Noise Excessive

This is symptom tree T047.

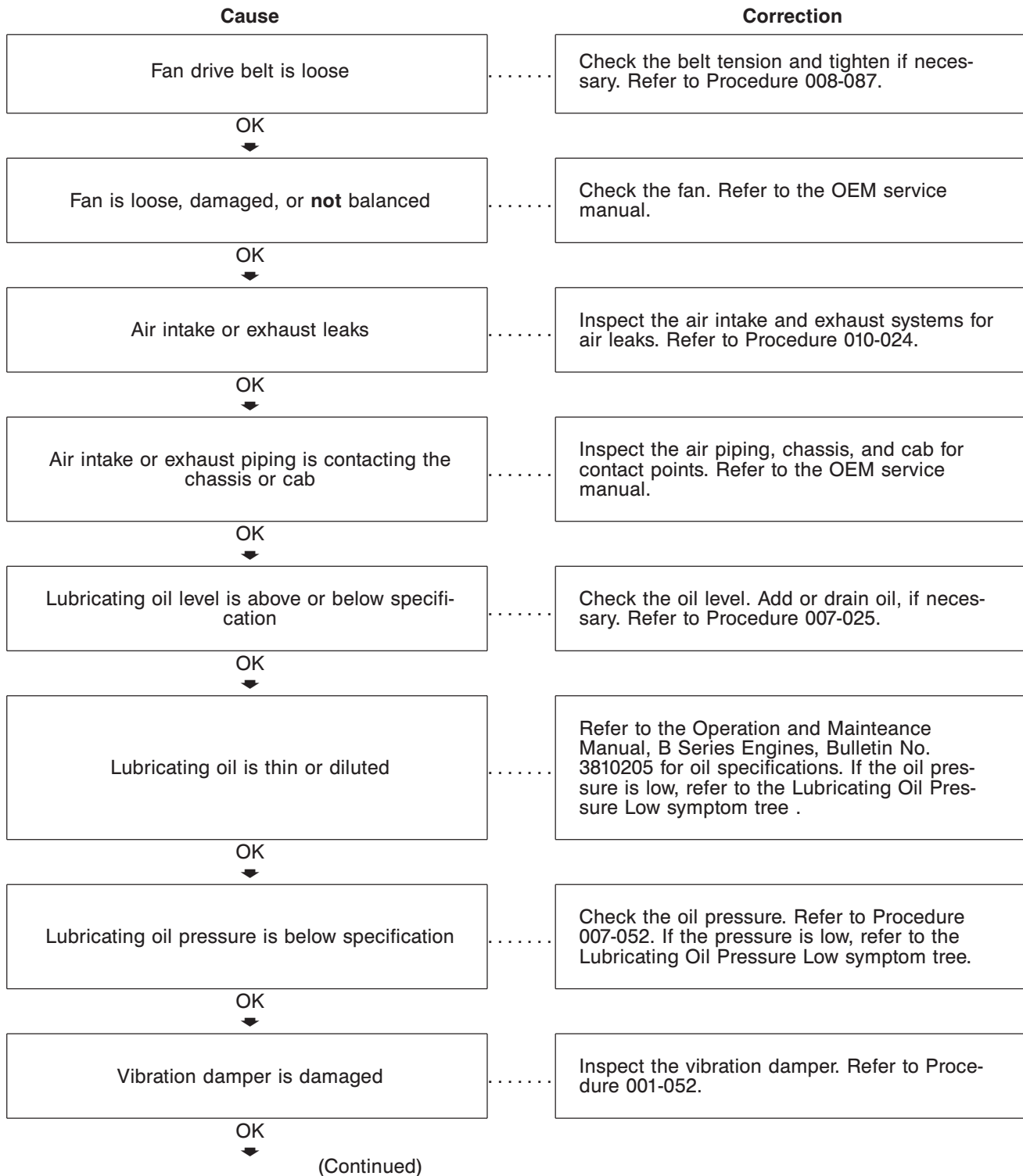

Engine Noise Excessive (Continued)

Cause	Correction
Accessory drive is worn (axial end play is out of specification)	Check the accessory drive axial end play. Inspect the shaft for wear. Refer to Procedure 009-019.
OK ↓	
Coolant temperature is above specification	Refer to the Coolant Temperature Above Normal - Gradual Overheat symptom tree.
OK ↓	
Drivetrain noise is excessive	Disconnect the drivetrain. Check for engine noise. Refer to the OEM service manual.
OK ↓	
Engine mounts are worn, damaged, or <b>not</b> correct	Check the engine mounts. Refer to the OEM service manual and Procedure 016-003.
OK ↓	
Overhead adjustments are <b>not</b> correct	Measure and adjust the overhead settings. Refer to Procedure 003-004.
OK ↓	
Overhead components are damaged	Inspect the rocker levers, rocker shafts, and valves for damage or excessive wear. Refer to Procedure 003-008.
OK ↓	
Injector is malfunctioning	Perform the single-cylinder cutout test. Replace the injectors as necessary. Refer to Procedure 006-026 or 014-008.
OK ↓	
Turbocharger noise	Refer to the Engine Noise Excessive - Turbocharger symptom tree.
OK ↓	
Combustion noise excessive	Refer to the Engine Noise Excessive symptom tree.
OK ↓	

(Continued)

**Engine Noise Excessive (Continued)**

Cause	Correction
Flywheel or flexplate capscrews are loose or broken	Check the flywheel or flexplate and the mounting capscrews. Refer to Procedure 016-005.
OK ↓	
Torque converter is loose	Check the torque converter. Refer to the OEM service manual.
OK ↓	
Main bearing or connecting rod bearing noise	Refer to Procedure 001-005 and 001-006.
OK ↓	
Piston or piston rings are worn, or damaged	Check for air intake system leaks. Refer to Procedure 010-024. Check the pistons and piston rings for wear or damage. Refer to Procedure 001-043 and 001-047.

### Engine Noise Excessive — Combustion Knocks

This is symptom tree T048.

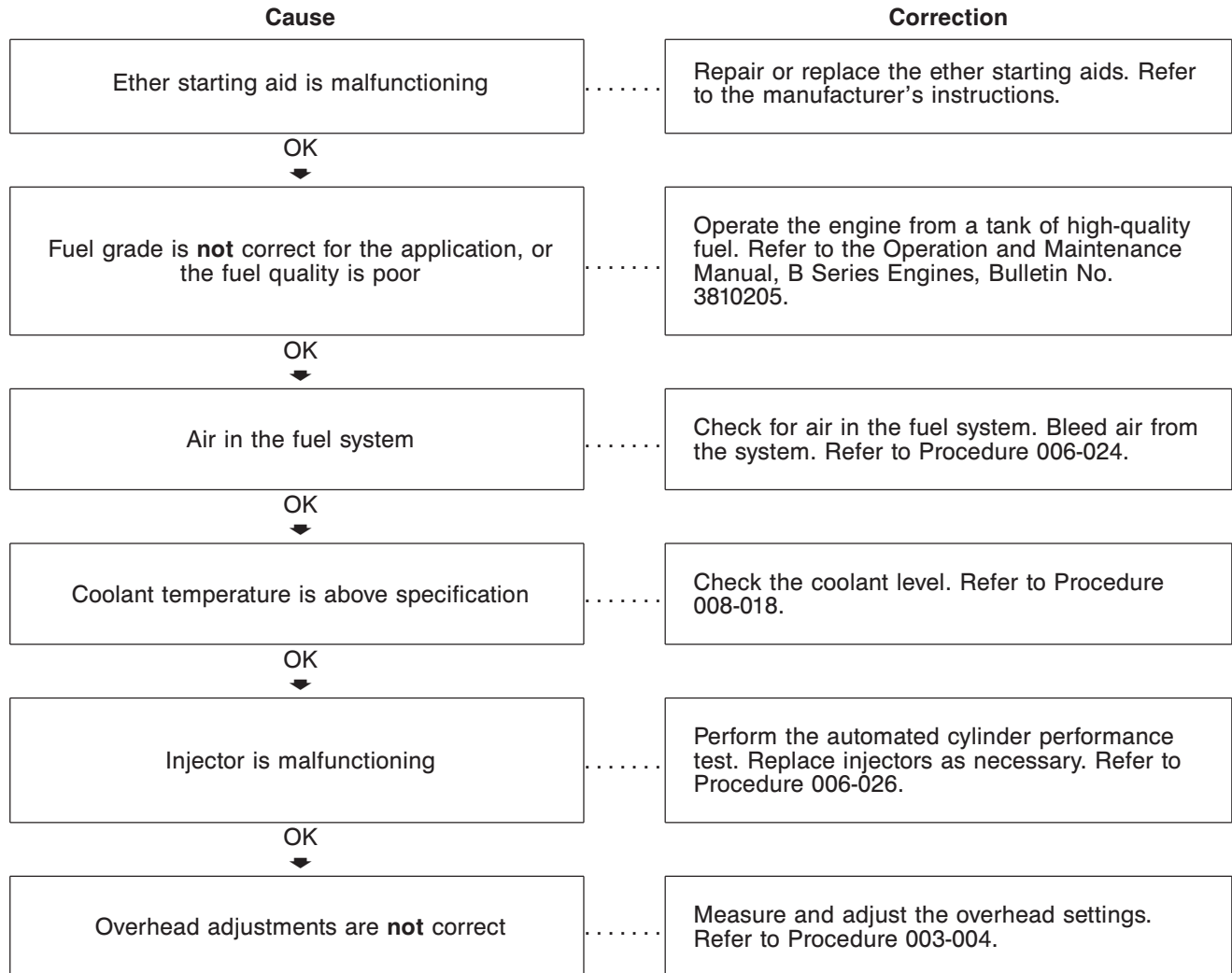

### Engine Noise Excessive — Connecting Rod

This is symptom tree T049.

**Cause**

**Correction**

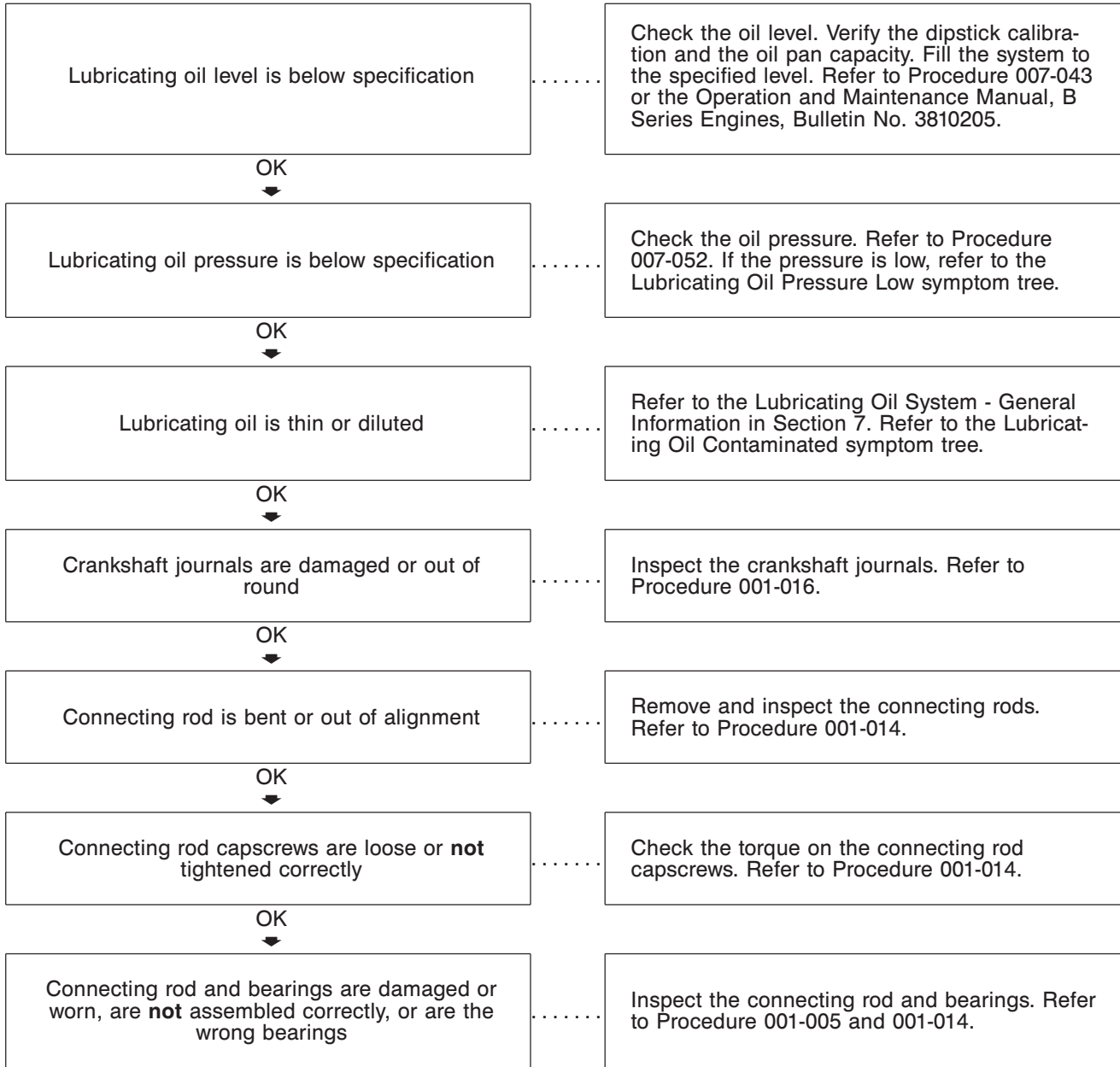



### Engine Noise Excessive — Main Bearing

This is symptom tree T050.

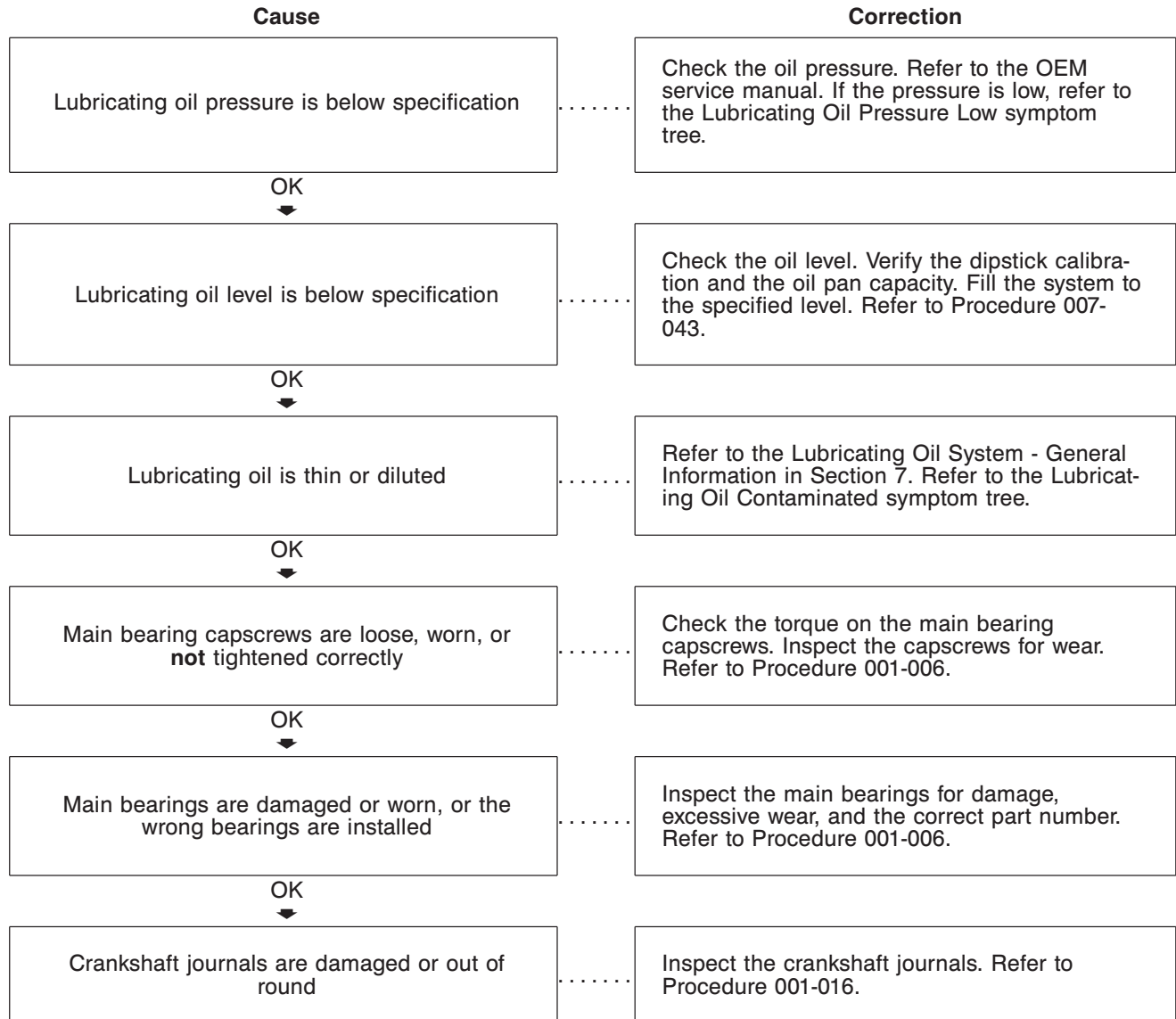

### Engine Noise Excessive — Piston

This is symptom tree T051.

**Cause**

**Correction**

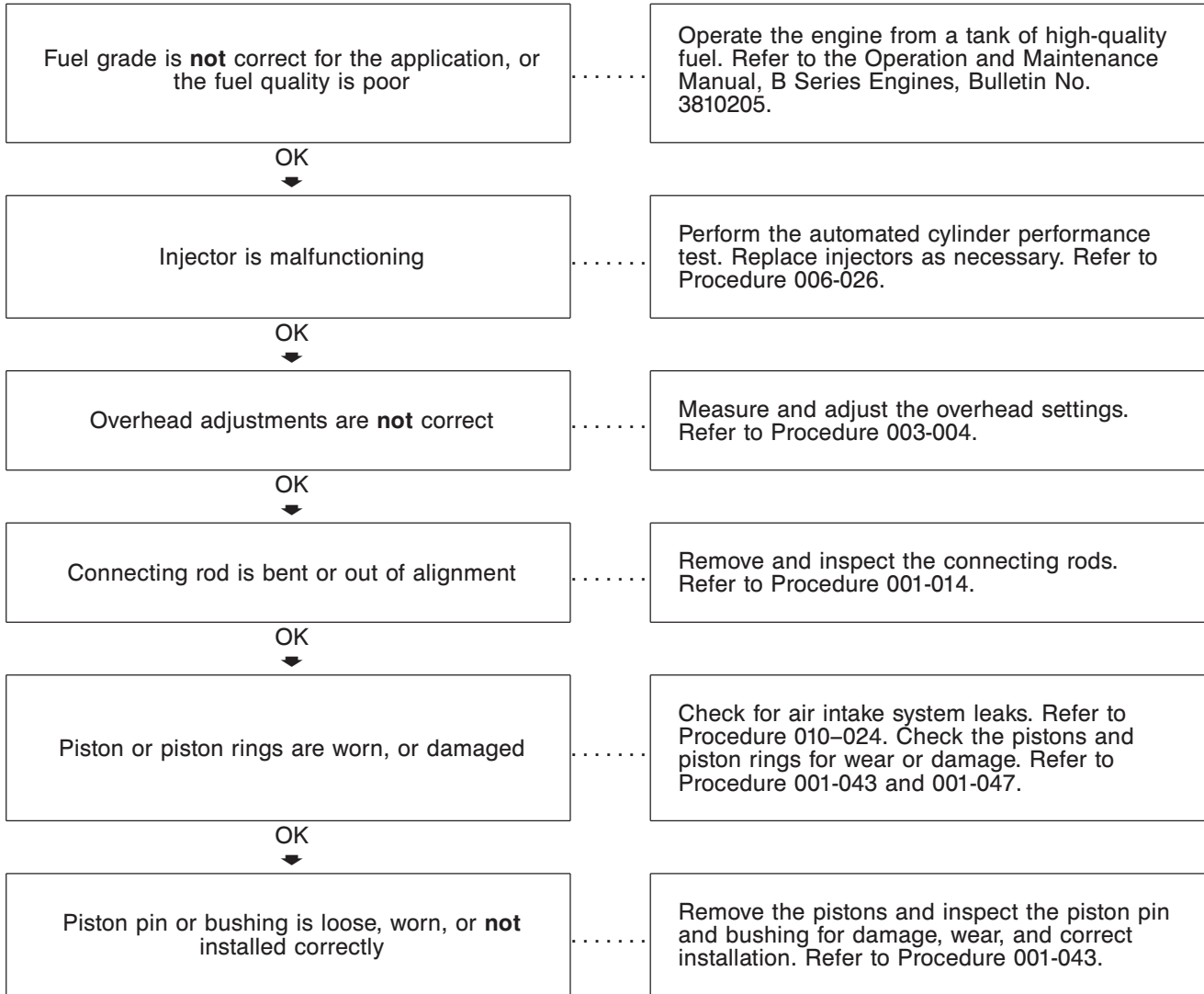

### Engine Noise Excessive — Turbocharger

This is symptom tree T052.

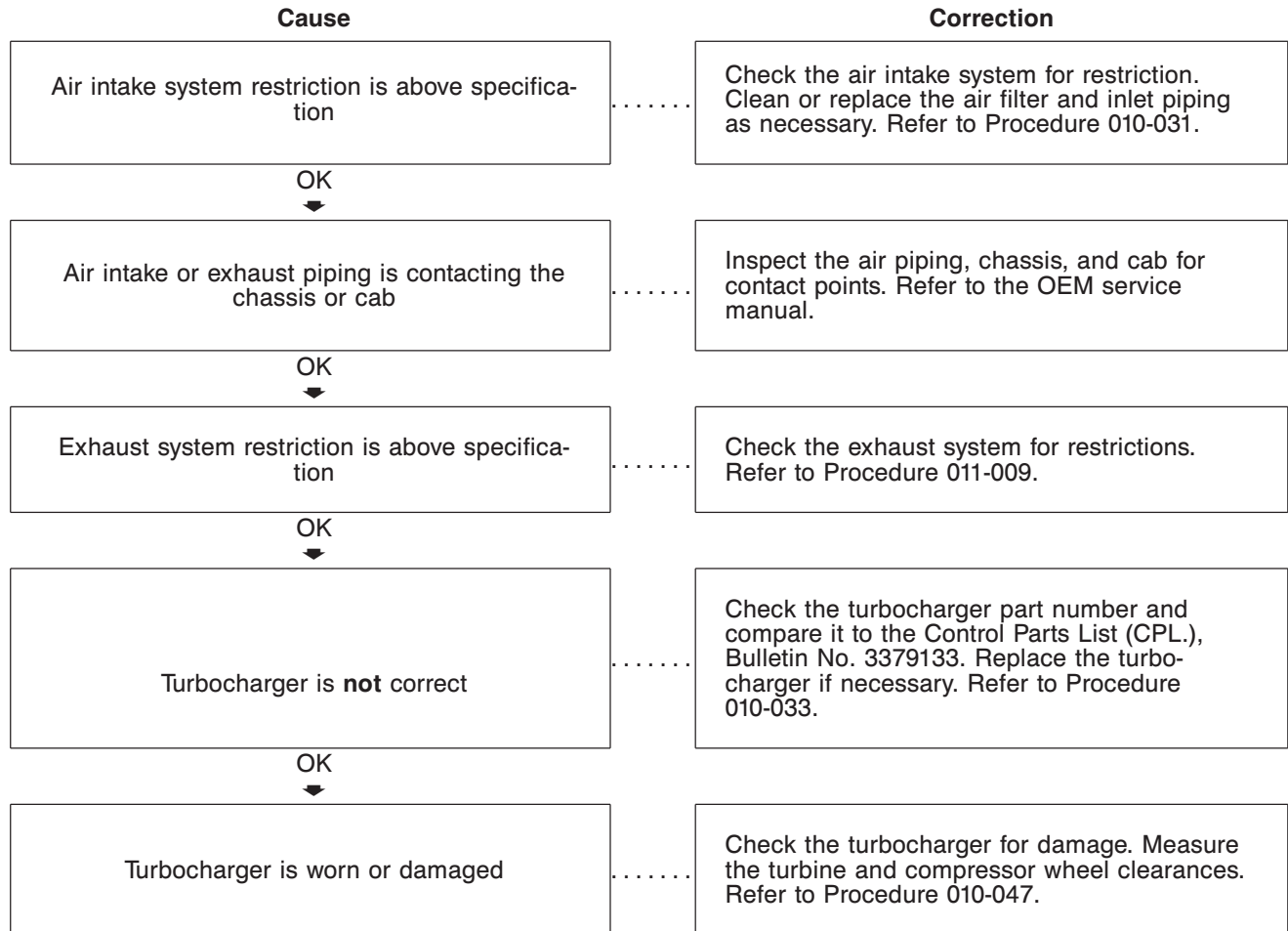

### Engine Power Output Low

This is symptom tree T057.

**Cause**

**Correction**

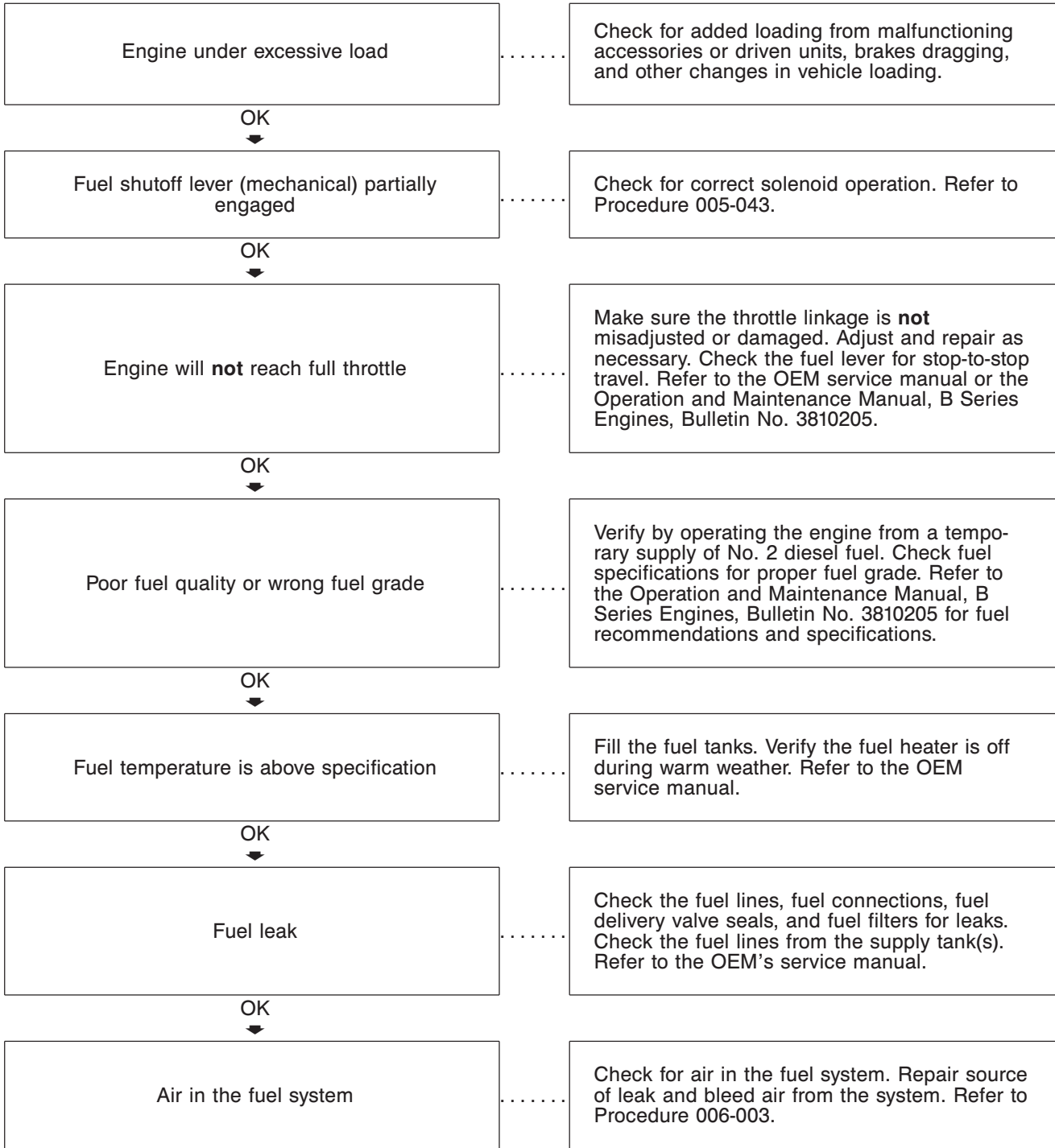

OK  
↓

(Continued)

**Engine Power Output Low (Continued)**

Cause	Correction
Fuel filter or fuel inlet restriction	Check the flow through the fuel filter. Replace the fuel filter if necessary. Refer to Procedure 006-015. Clean all prefilters and screens. Check the fuel suction line for restriction.
OK ↓	
Fuel drain line is restricted	Check the fuel drain lines for restriction. Clear or replace the fuel lines, check valves, or tank vents as necessary. Refer to Procedure 006-012.
OK ↓	
Fuel transfer pump malfunctioning	Inspect the fuel transfer pump. Replace if necessary. Refer to Procedure 005-045.
OK ↓	
Fuel pump return overflow valve is malfunctioning	Inspect the return overflow valve. Replace if necessary. Refer to Procedure 006-044.
OK ↓	
Lubricating oil level is above or below specification	Check the oil level. Add or drain oil, if necessary. Refer to Procedure 007-043.
OK ↓	
Plugged air filter	Inspect the air cleaner element. Replace as needed. Refer to the OEM service manual or the Operation and Maintenance Manual, B Series Engines, Bulletin No. 3810205.
OK ↓	
Intake air source is incorrect	If the vehicle is equipped with a valve switch the intake source from under the hood to outside, position and valve for the season.
OK ↓	
Air fuel tube leaking, wastegate diaphragm ruptured, or wastegate plumbing damaged	Tighten the fittings, repair plumbing, replace wastegate diaphragm. Refer to Procedure 010-050 or the Turbocharger Master Repair Manual, Bulletin No. 3580555.
OK ↓	
(Continued)	

Engine Power Output Low (Continued)

Cause	Correction
Intake air overheated	Inspect and clean any debris from the front of the charge-air cooler. Refer to Procedure 010-024.
OK ↓	
Aftercooler restricted (if equipped)	Inspect for plugged passages in the after-cooler. Refer to Procedure 010-001.
OK ↓	
Charge-air cooler restricted (if equipped)	Inspect the air cooler for internal and external restriction. Replace the restricted cooler if necessary. Refer to Procedure 010-024.
OK ↓	
Intake and exhaust system restricted	Check the intake and exhaust systems for restrictions. Inspect the intake air filter and replace as necessary. Refer to Procedure 010-031 or 011-009.
OK ↓	
Air leak between the turbocharger and the intake manifold	Check for leaks in the air crossover tube, charge-air cooler connections, hoses, or through holes in the manifold cover and repair or replace if necessary. Refer to Section 10.
OK ↓	
Turbocharger is worn or malfunctioning	Check for the specified boost pressure. Inspect the turbocharger. Replace if necessary. Refer to Procedure 010-033.
OK ↓	
Fuel injection pump timing is <b>not</b> correct	Put the engine at top dead center. Check and adjust the fuel timing. Refer to Procedure 005-013, 005-014, or 005-037.
OK ↓	
Valves are <b>not</b> sealing correctly	Check and adjust the valves. Refer to Procedure 003-004.
OK ↓	
(Continued)	

**Engine Power Output Low (Continued)**

Cause	Correction
Injector sealing washer <b>not</b> correct	Check to see if an extra sealing washer is installed under injector. Remove any additional sealing washer. <b>Only</b> one is required. Refer to Procedure 006-026.
OK ↓	
Injectors worn or malfunctioning	Check the injectors and replace any malfunctioning injectors. Refer to Procedure 006-026.
OK ↓	
Engine compression is low	Perform the compression check to identify the malfunction. Correct as required. Refer to Procedure 014-008.
OK ↓	
Fuel injection pump is malfunctioning	Remove the fuel pump. Refer to Procedure 005-012 or 005-014. Calibrate the fuel pump.

### Engine Runs Rough at Idle

This is symptom tree T061.

**Cause**

**Correction**

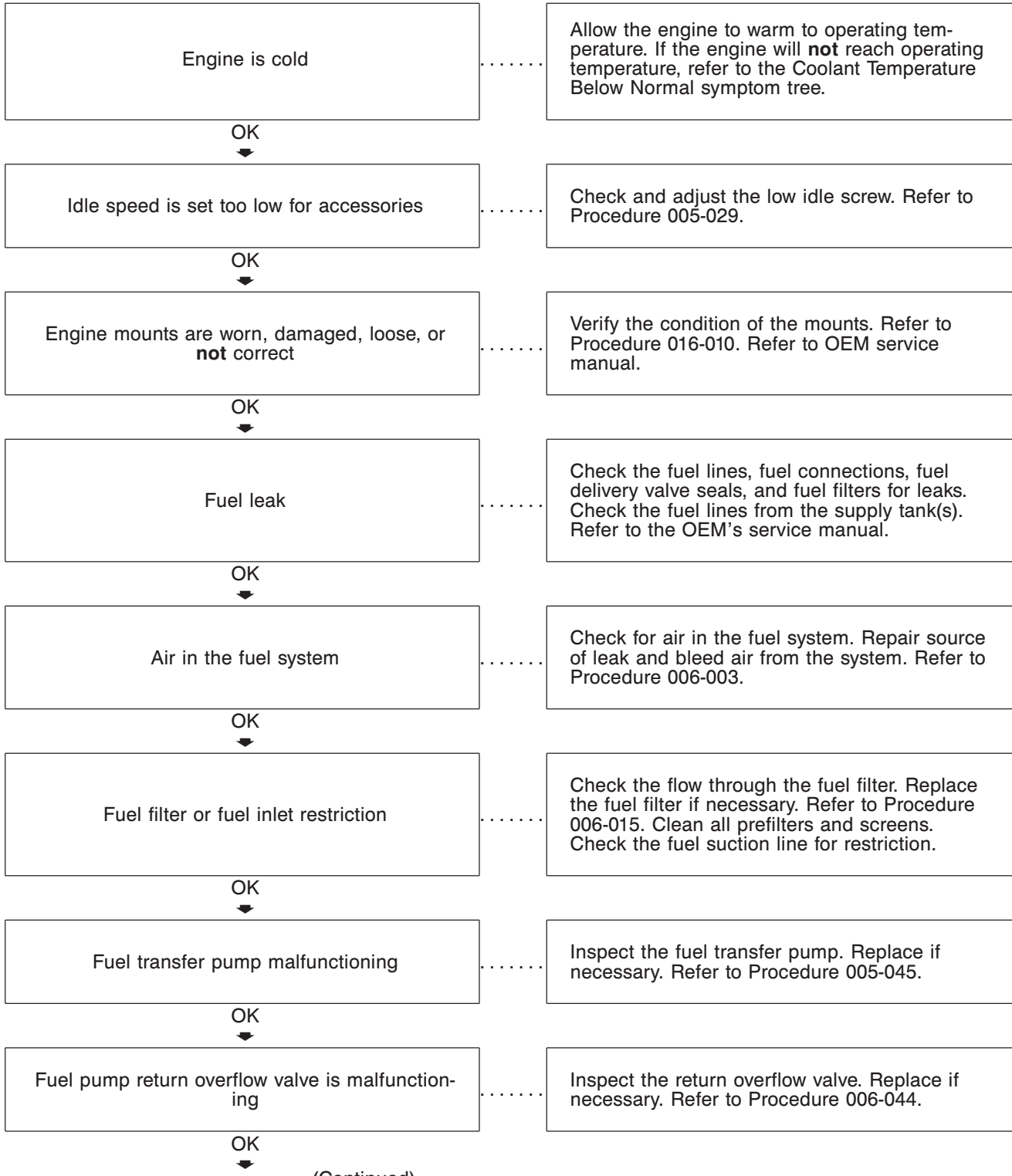

(Continued)



**Engine Runs Rough at Idle (Continued)**

Cause	Correction
Fuel injection pump timing is <b>not</b> correct	Put the engine at top dead center. Check and adjust the fuel timing. Refer to Procedure 005-013, 005-014, or 005-037.
OK ↓	
Valves are <b>not</b> sealing correctly	Check and adjust the valves. Refer to Procedure 003-004.
OK ↓	
Engine compression is low	Perform the compression check to identify the malfunction. Correct as required. Refer to Procedure 014-008.
OK ↓	
Injector is malfunctioning	Perform a pot test on the injector(s). Refer to Procedure 006-026.
OK ↓	
Fuel injection pump is malfunctioning	Remove the fuel pump. Refer to Procedure 005-012 or 005-014. Calibrate the fuel pump.

### Engine Runs Rough or Misfires

This is symptom tree T062.

**Cause**

**Correction**

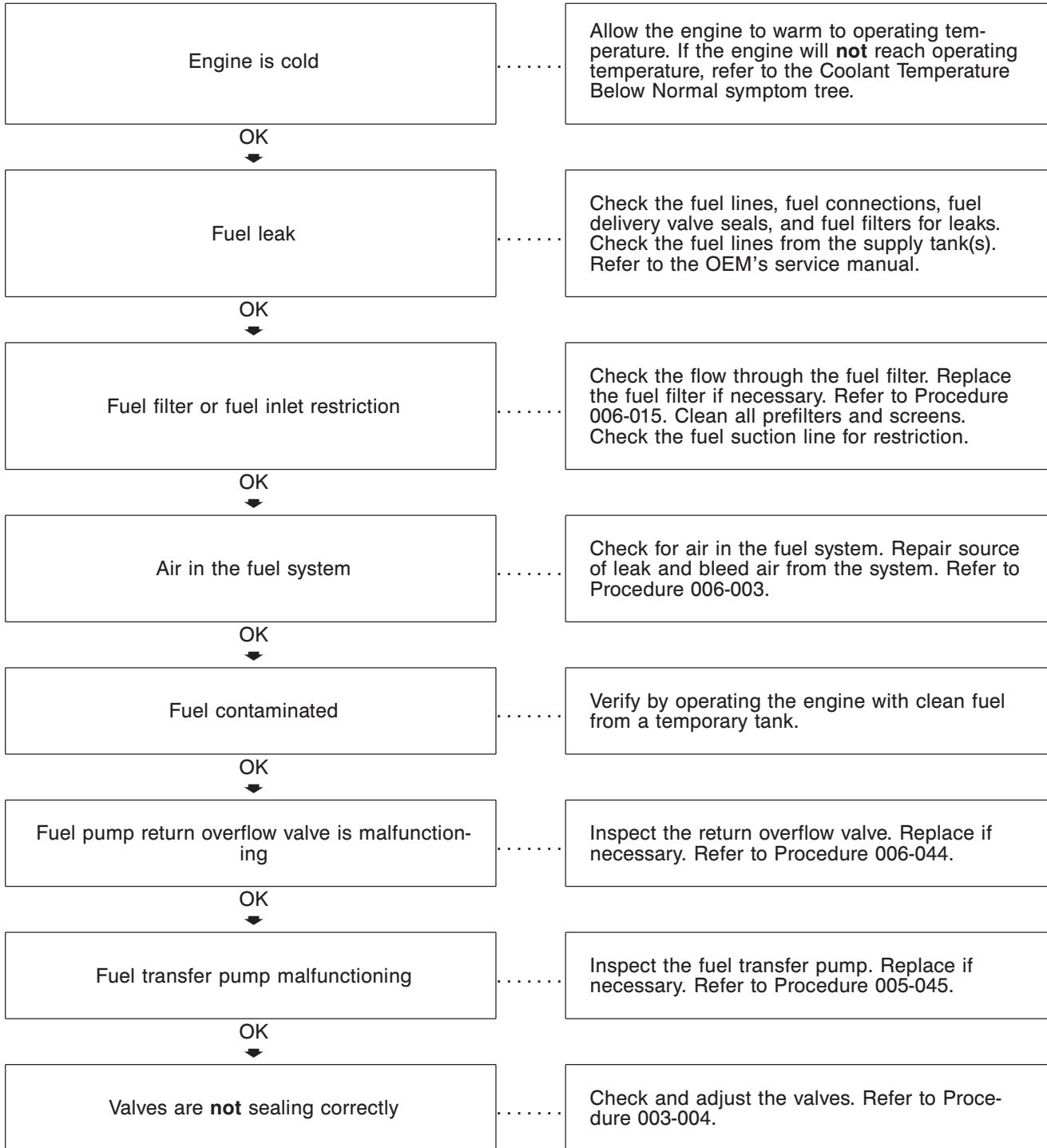

OK  
↓

(Continued)

**Engine Runs Rough or Misfires (Continued)**

Cause	Correction
Injectors worn or malfunctioning	Check the injectors and replace any malfunctioning injectors. Refer to Procedure 006-026.
OK ↓	
Engine compression is low	Perform the compression check to identify the malfunction. Correct as required. Refer to Procedure 014-008.
OK ↓	
Fuel injection pump is malfunctioning	Remove the fuel pump. Refer to Procedure 005-012 or 005-014. Calibrate the fuel pump.
OK ↓	
Camshaft timing is <b>not</b> correct (after engine rebuild or repair)	Check the gear train timing alignment. Refer to Procedure 001-008.
OK ↓	
Camshaft, tappets, or pushrods are damaged	Inspect the camshaft and tappets. Refer to Procedure 001-008 or 004-015.

### Engine Speed Surges at Low or High Idle

This is symptom tree T066.

**Cause**

**Correction**

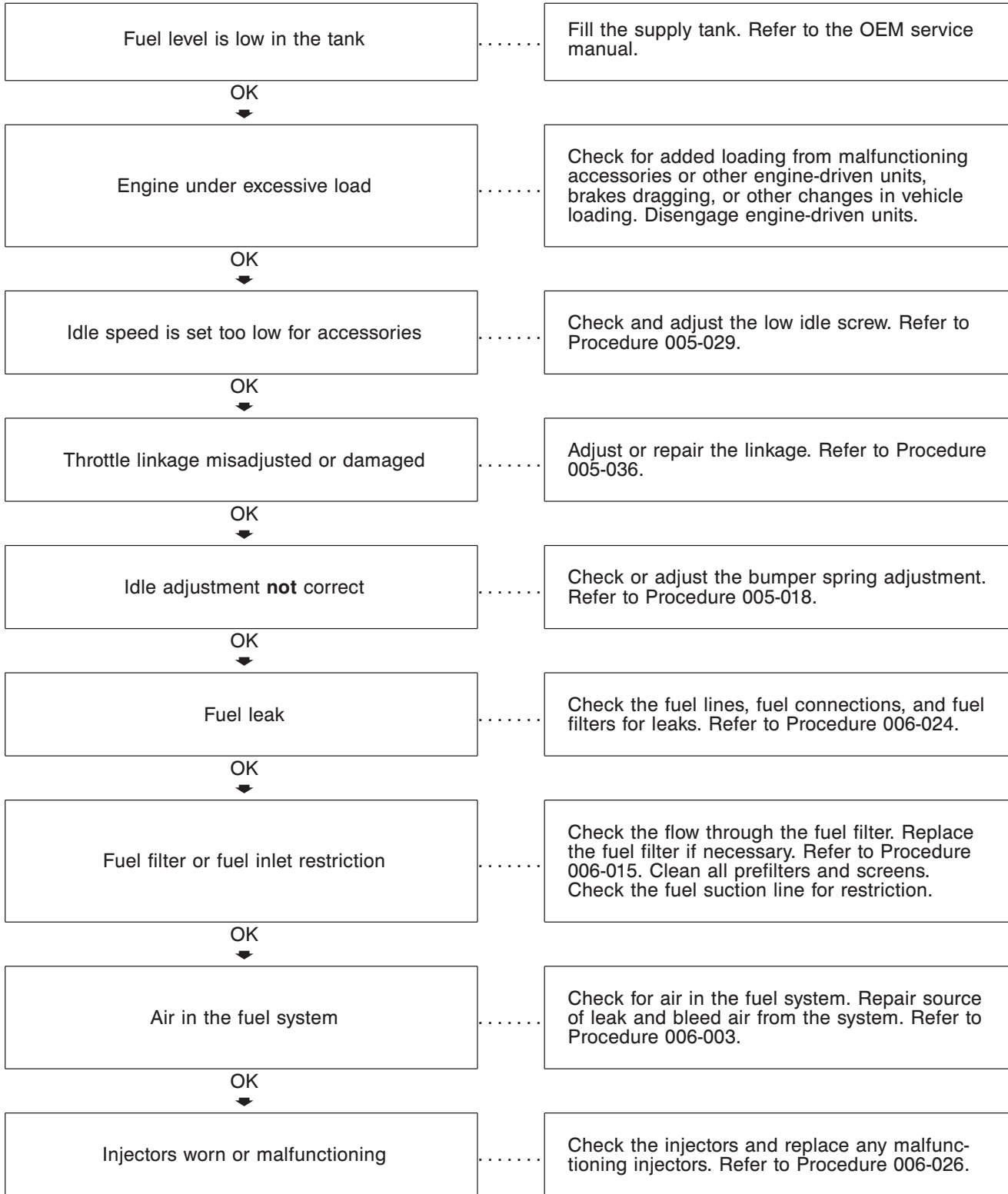

OK  
↓

(Continued)

**Engine Speed Surges at Low or High Idle (Continued)**

**Cause**

**Correction**

Fuel injection pump is malfunctioning

Remove the fuel injection pump. Check the calibration of the fuel injection pump. Refer to Procedure 005-012 or 005-014.

### Engine Starts But Will Not Keep Running

This is symptom tree T072.

**Cause**

**Correction**

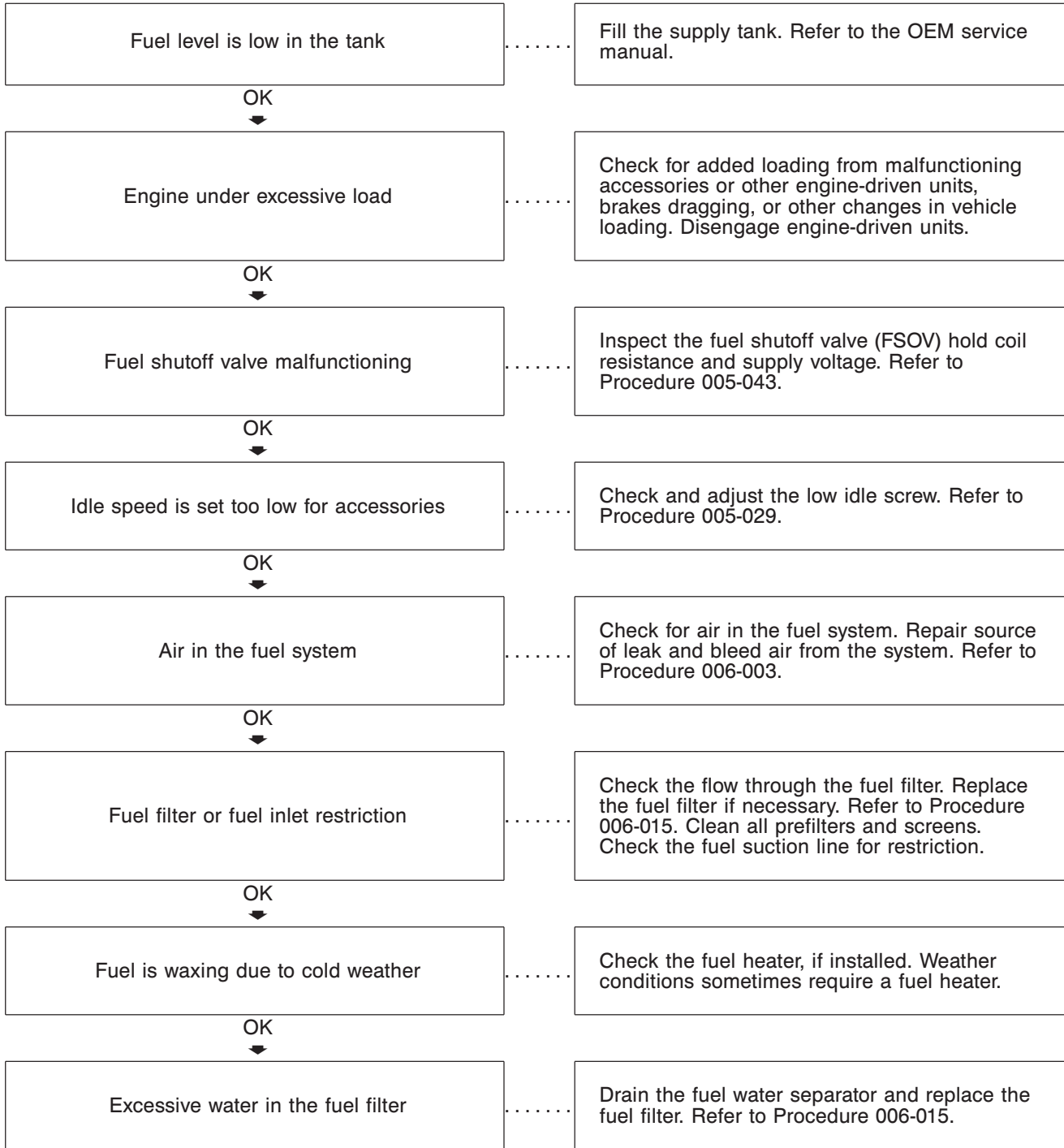

OK  
↓

(Continued)

**Engine Starts But Will Not Keep Running (Continued)**

Cause	Correction
Fuel contaminated	Verify by operating the engine with clean fuel from a temporary tank.
OK ↓	
Fuel drain line is restricted	Check the fuel drain lines for restriction. Clear or replace the fuel lines, check valves, or tank vents as necessary. Refer to Procedure 006-012.
OK ↓	
Intake and exhaust system restricted	Check the intake and exhaust systems for restrictions. Inspect the intake air filter and replace as necessary. Refer to Procedure 010-031 or 011-009.
OK ↓	
Injectors worn or malfunctioning	Check the injectors and replace any malfunctioning injectors. Refer to Procedure 006-026.
OK ↓	
Fuel injection pump timing is <b>not</b> correct	Put the engine at top dead center. Check and adjust the fuel timing. Refer to Procedure 005-013, 005-014, or 005-037.
OK ↓	
Fuel injection pump is malfunctioning	Remove the fuel injection pump. Check the calibration of the fuel injection pump. Refer to Procedure 005-012 or 005-014.

### Engine Vibration Excessive

This is symptom tree T075.

**Cause**

**Correction**

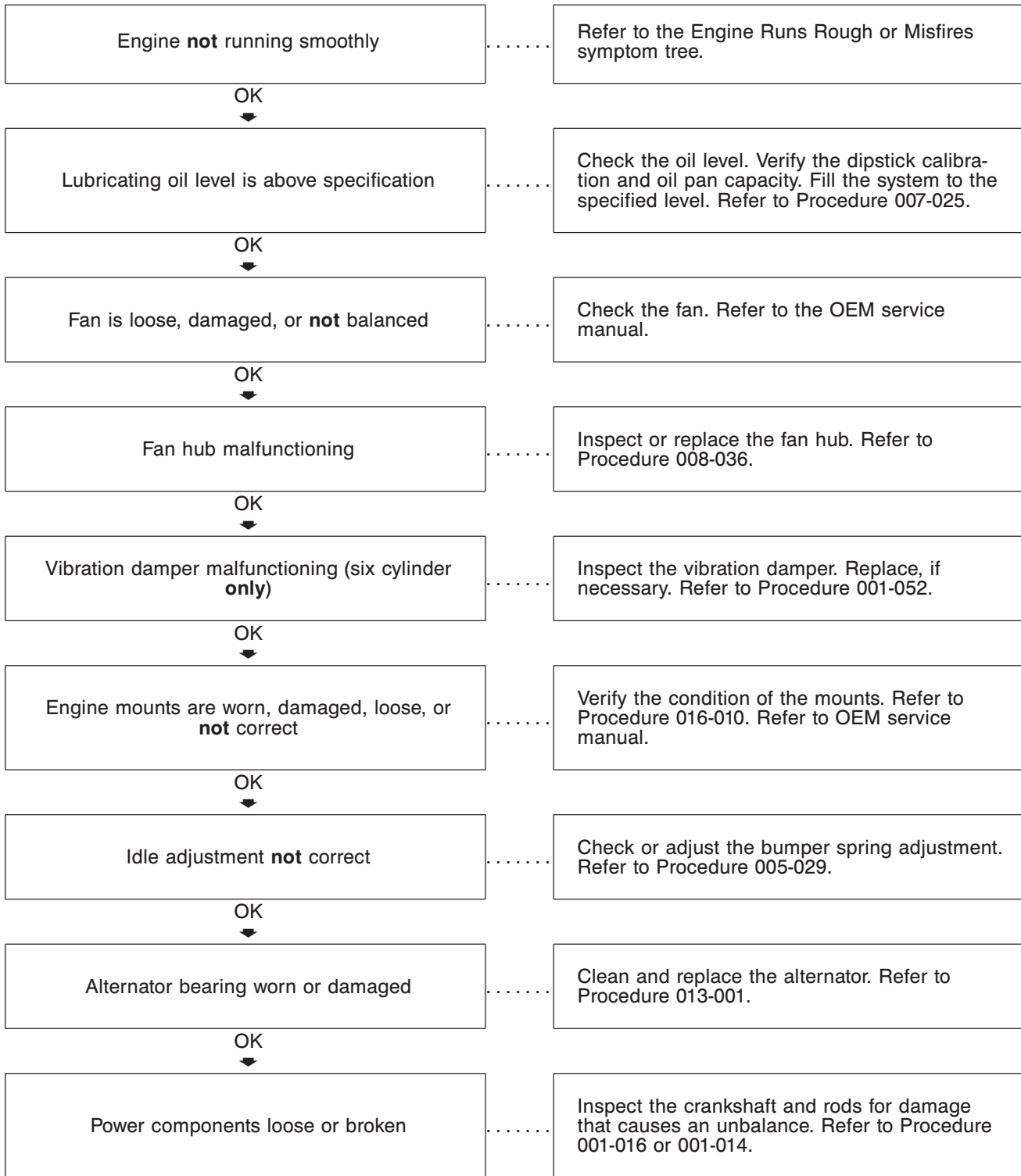

OK  
↓

(Continued)



### Engine Vibration Excessive (Continued)

Cause	Correction
Drivetrain components worn or unbalanced	Check or repair components if necessary. Refer to OEM service manual.
OK ▼	
Flywheel housing is <b>not</b> aligned correctly	Check the flywheel housing alignment. Refer to Procedure 016-006.

### Engine Will Not Crank or Cranks Slowly

This is symptom tree T076.

**Cause**

**Correction**

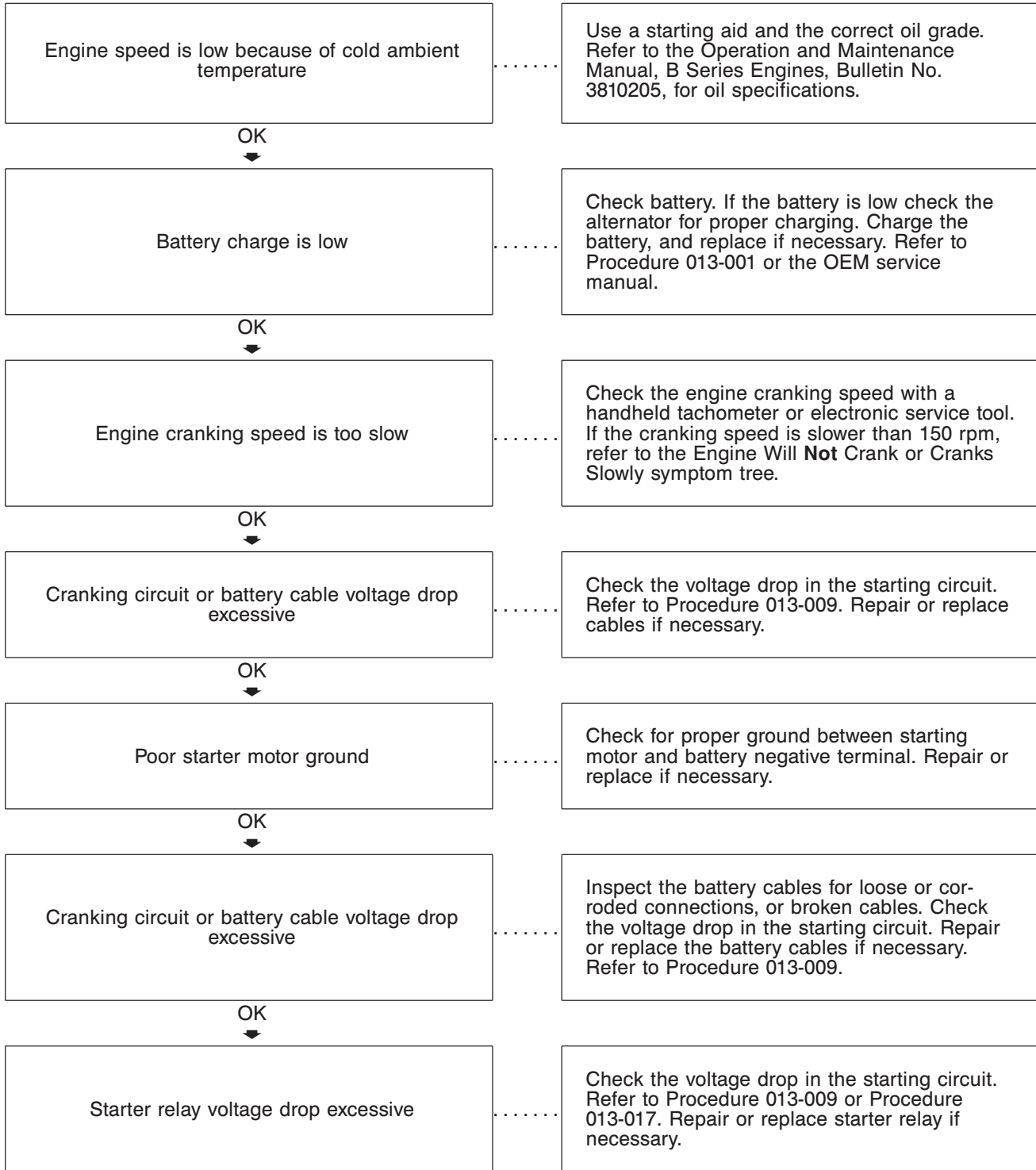

OK



(Continued)

**Engine Will Not Crank or Cranks Slowly (Continued)**

Cause	Correction
Starter solenoid voltage drop is excessive and amperage drain is too high	Check the starter solenoid voltage and amperage drop. Refer to Procedure 013-019.
OK ▼	
Engine rotation is restricted	Rotate the crankshaft using barring tool, Cummins Part No. 3824591.
OK ▼	
Starting motor pinion or ring gear is damaged	Remove the starting motor, and inspect the gear. Refer to Procedure 013-020 and the manufacturer's instructions.
OK ▼	
Starter motor will <b>not</b> engage or is malfunctioning	Replace starter motor. Refer to Procedure 013-020.

### Engine Will Not Reach High Idle

This is symptom tree T080-005.

**Cause**

**Correction**

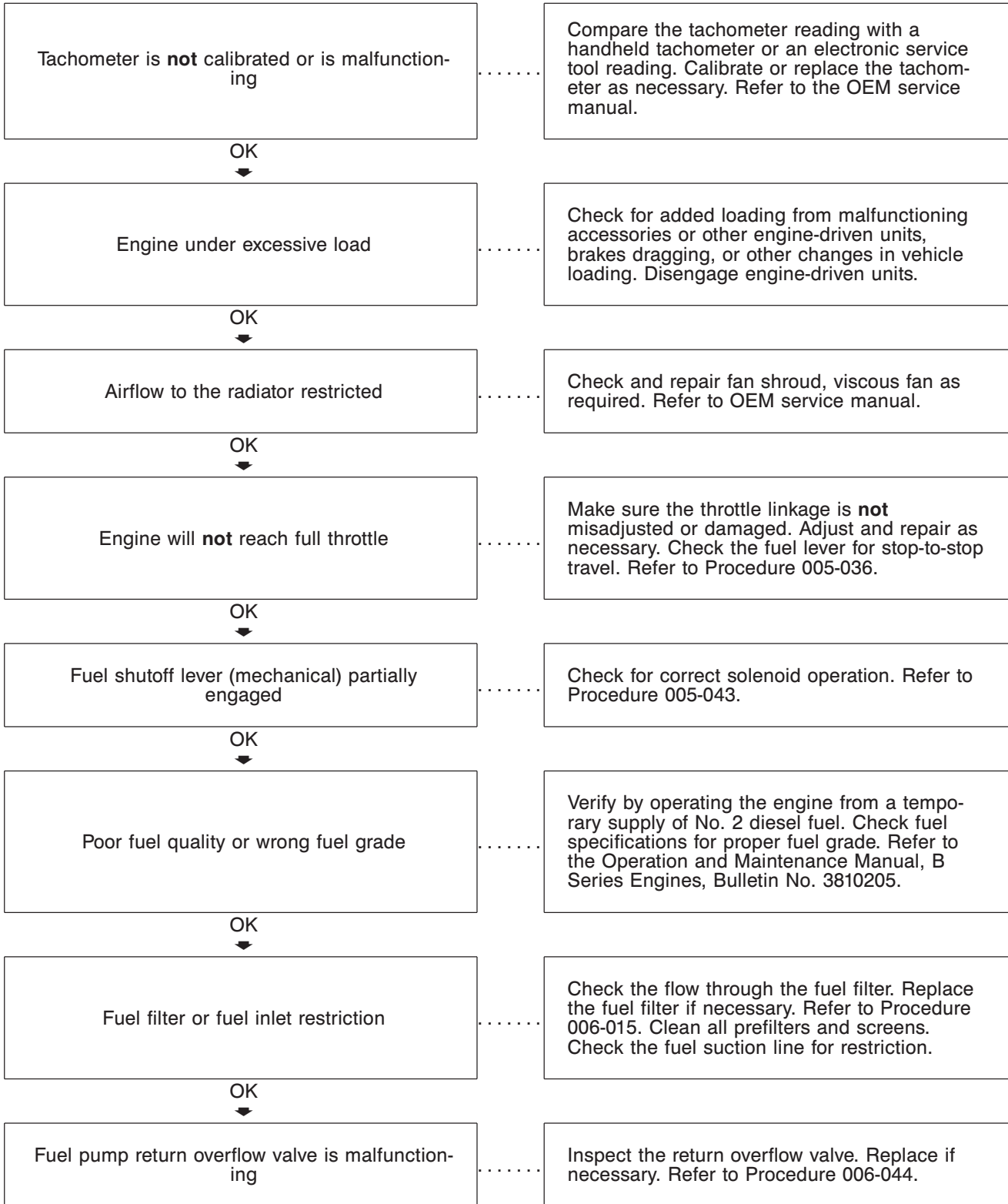

OK  
↓

(Continued)

**Engine Will Not Reach High Idle (Continued)**

Cause	Correction
Manifold drain line restricted (Lucas CAV DPA only)	Check and remove restriction. Refer to Procedure 006-021.
OK ↓	
Fuel transfer pump malfunctioning	Check or replace the fuel transfer pump. Refer to Procedure 005-045.
OK ↓	
Turbocharger wastegate is malfunctioning (if equipped)	Check the wastegate for correct operation. Refer to Procedure 010-050.
OK ↓	
Fuel injection pump is malfunctioning	Remove the fuel injection pump. Check the calibration of the fuel injection pump. Refer to Procedure 005-012 or 005-014.

### Engine Will Not Shut Off

This is symptom tree T081.

**Cause**

**Correction**

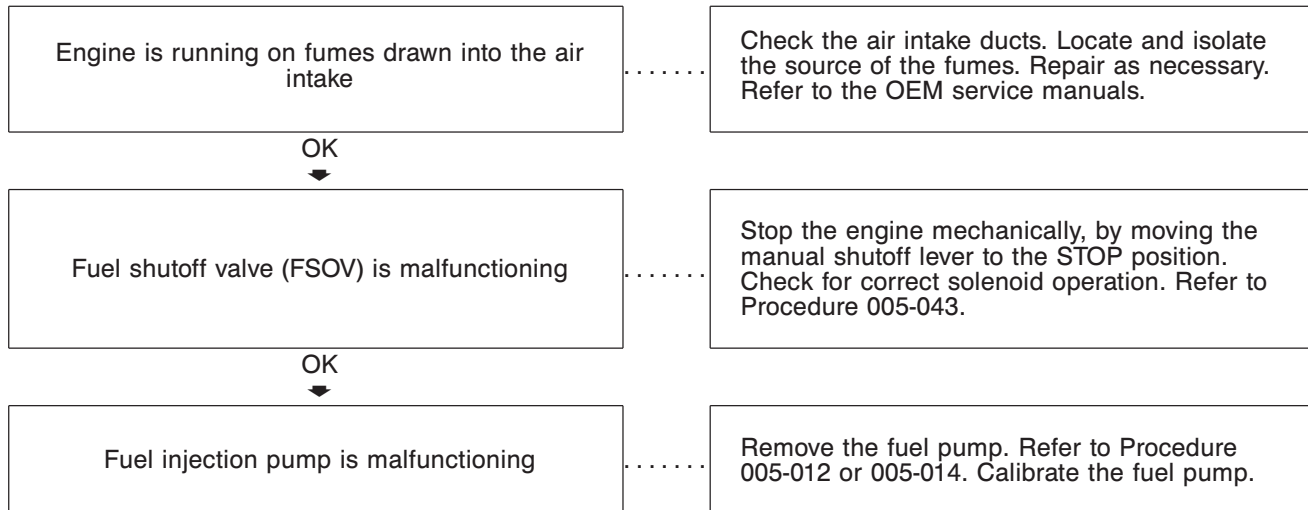

**Excessive Noise**

This is symptom tree T081-001.

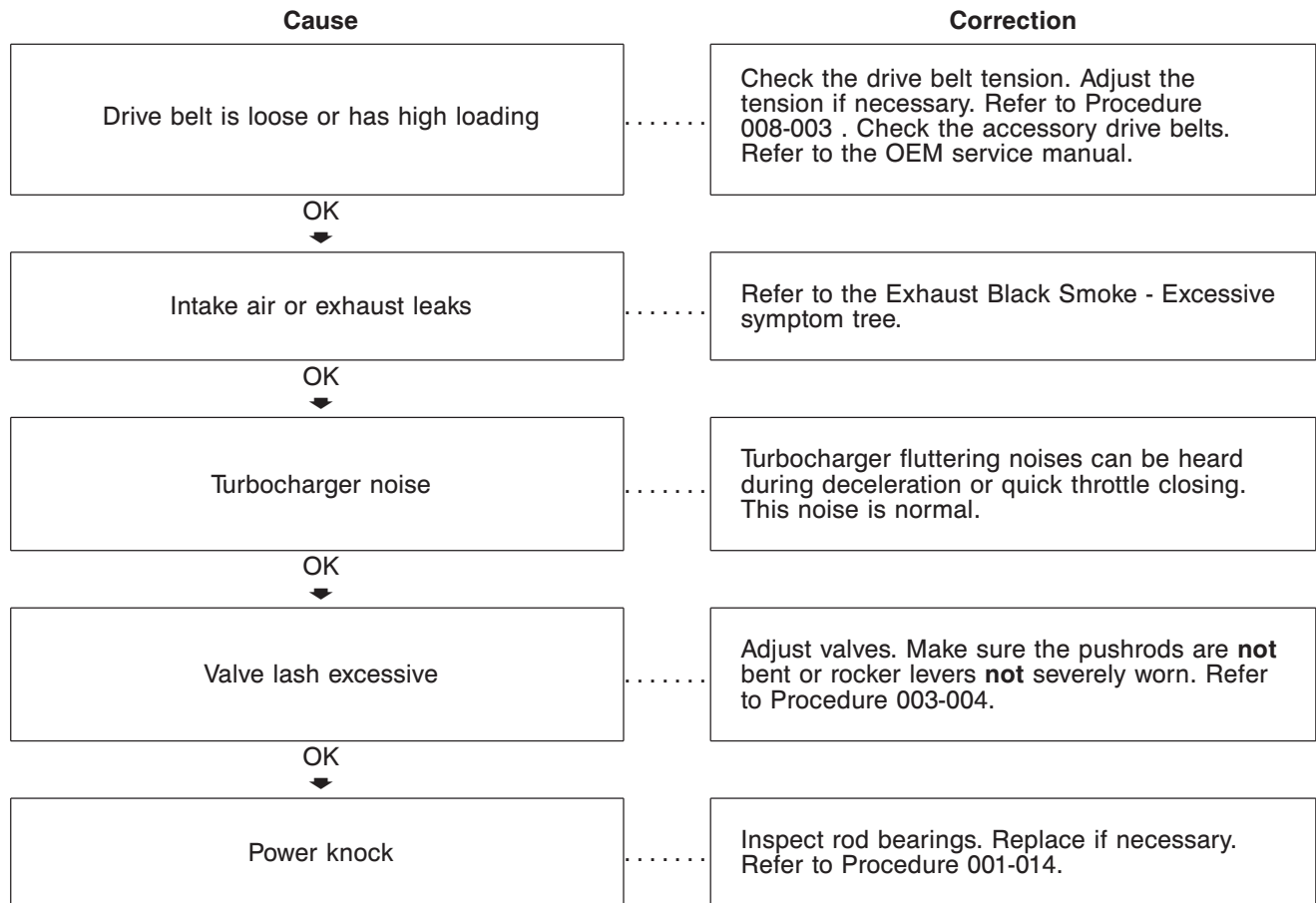

### Fuel Consumption Excessive

This is symptom tree T087.

**Cause**

**Correction**

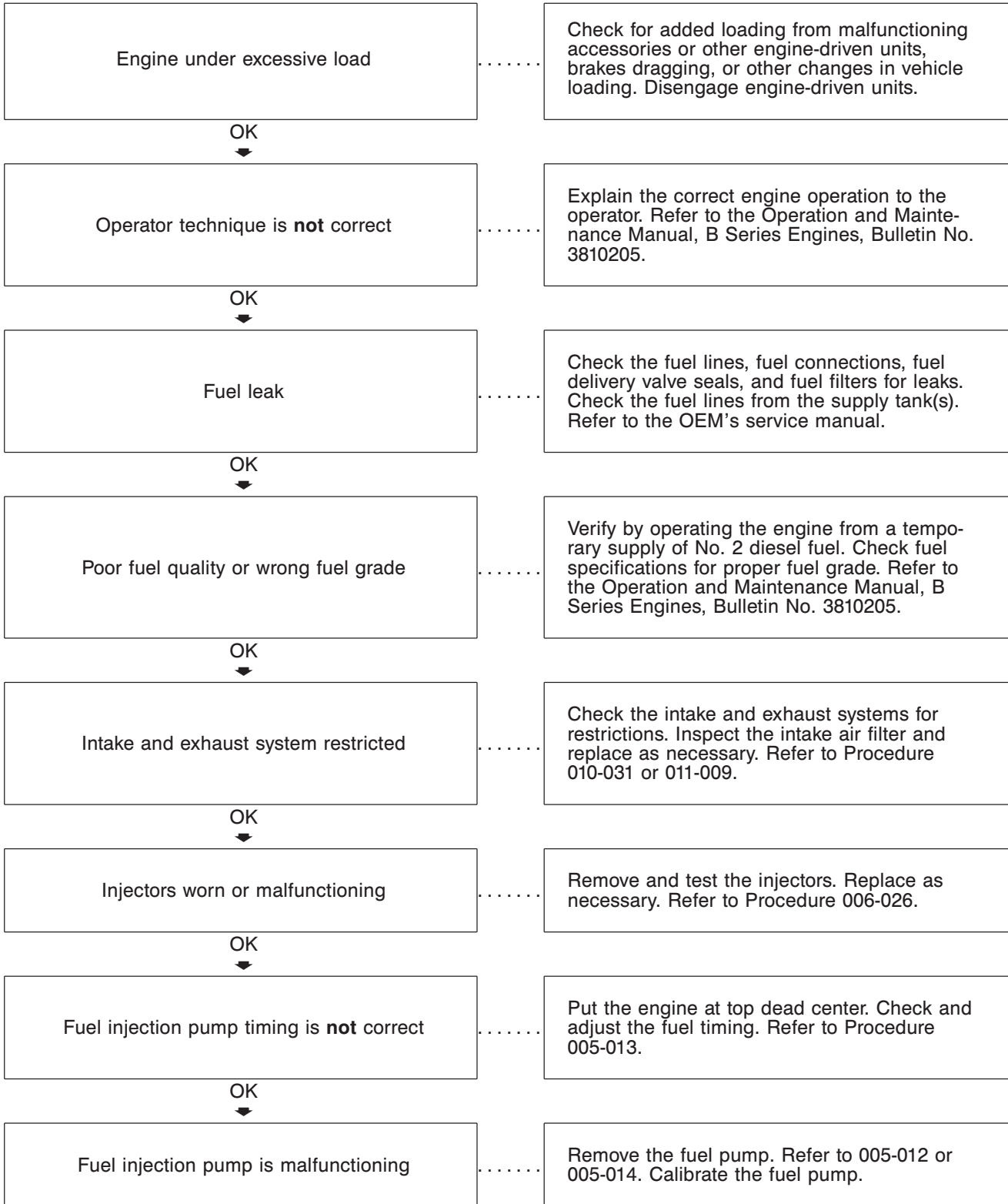

OK  
↓

(Continued)



**Fuel Consumption Excessive (Continued)**

**Cause**

**Correction**

Valves are **not** sealing correctly



Check and adjust the valves. Refer to Procedure 003-004.

### Fuel Knock

This is symptom tree T091-5.

**Cause**

**Correction**

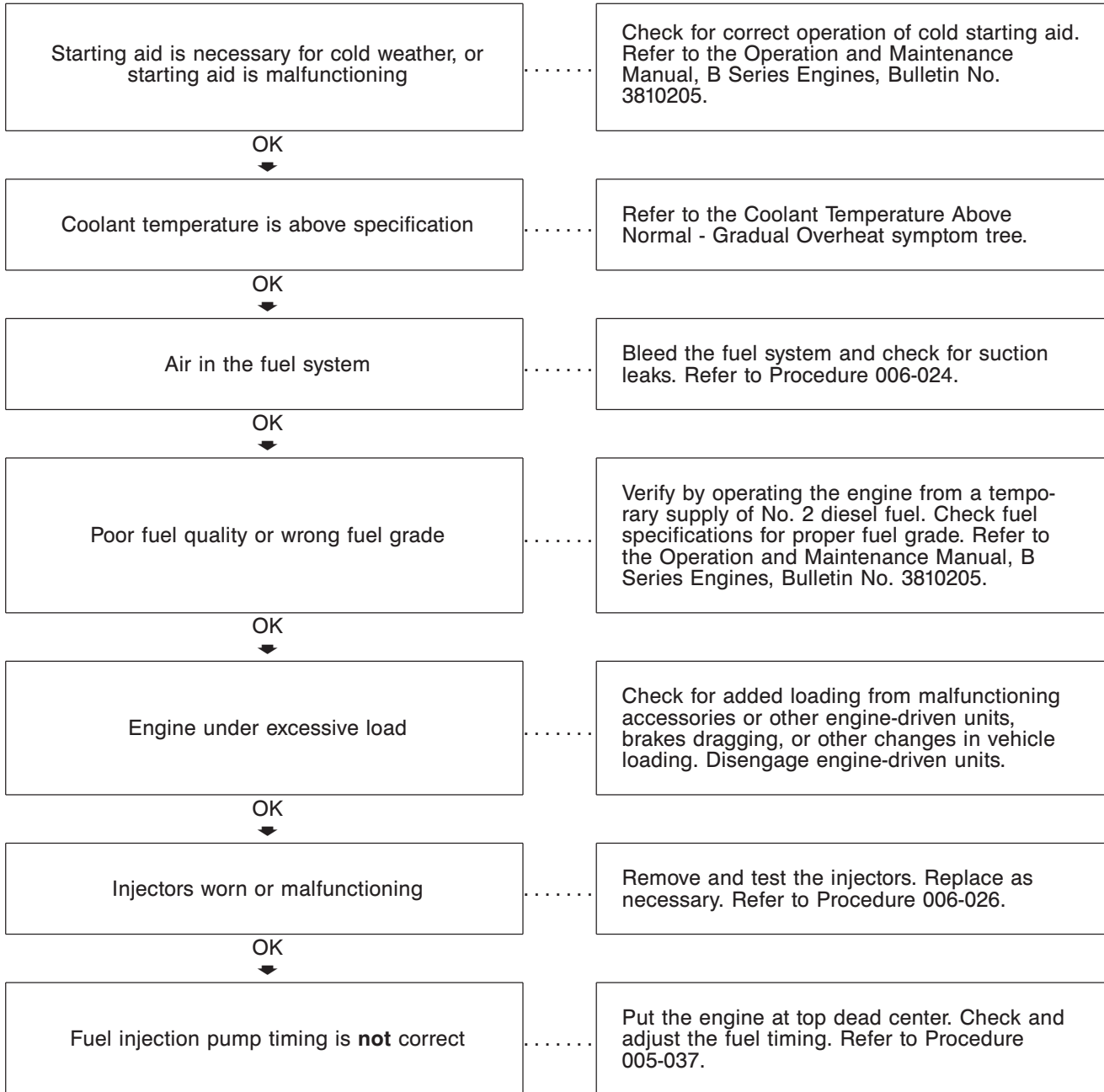

### Fuel in the Lubricating Oil

This is symptom tree T092.

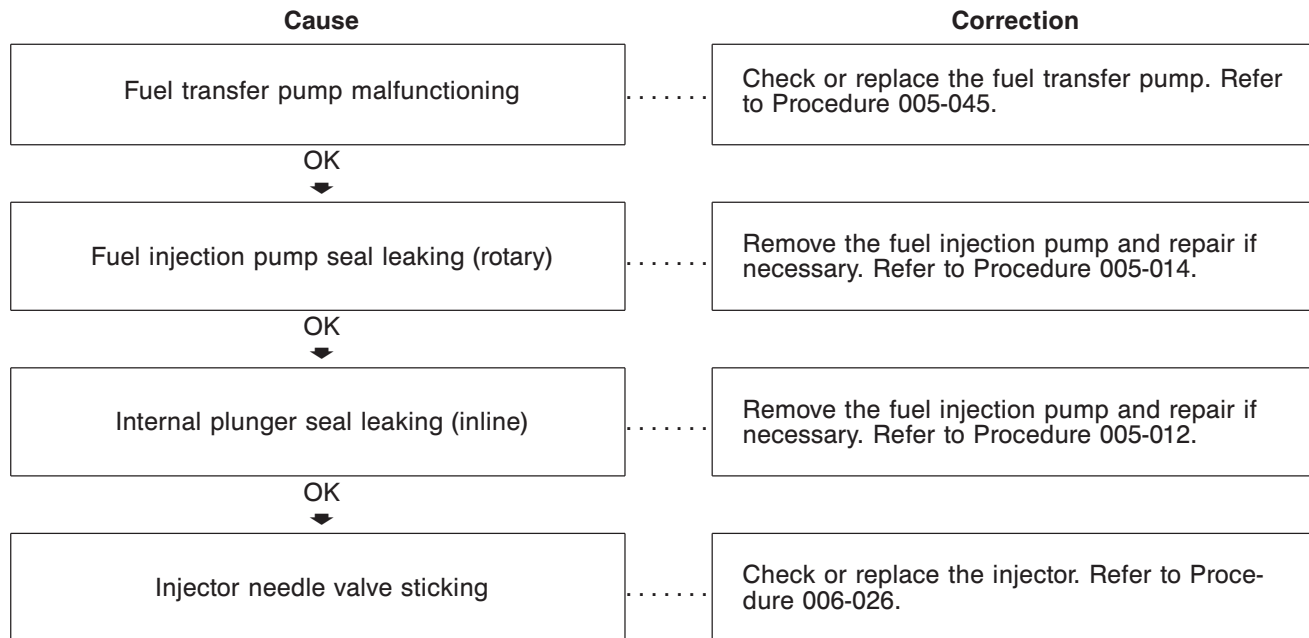

### Fuel or Lubricating Oil Leaking From Exhaust Manifold

This is symptom tree T093.

**Cause**

**Correction**

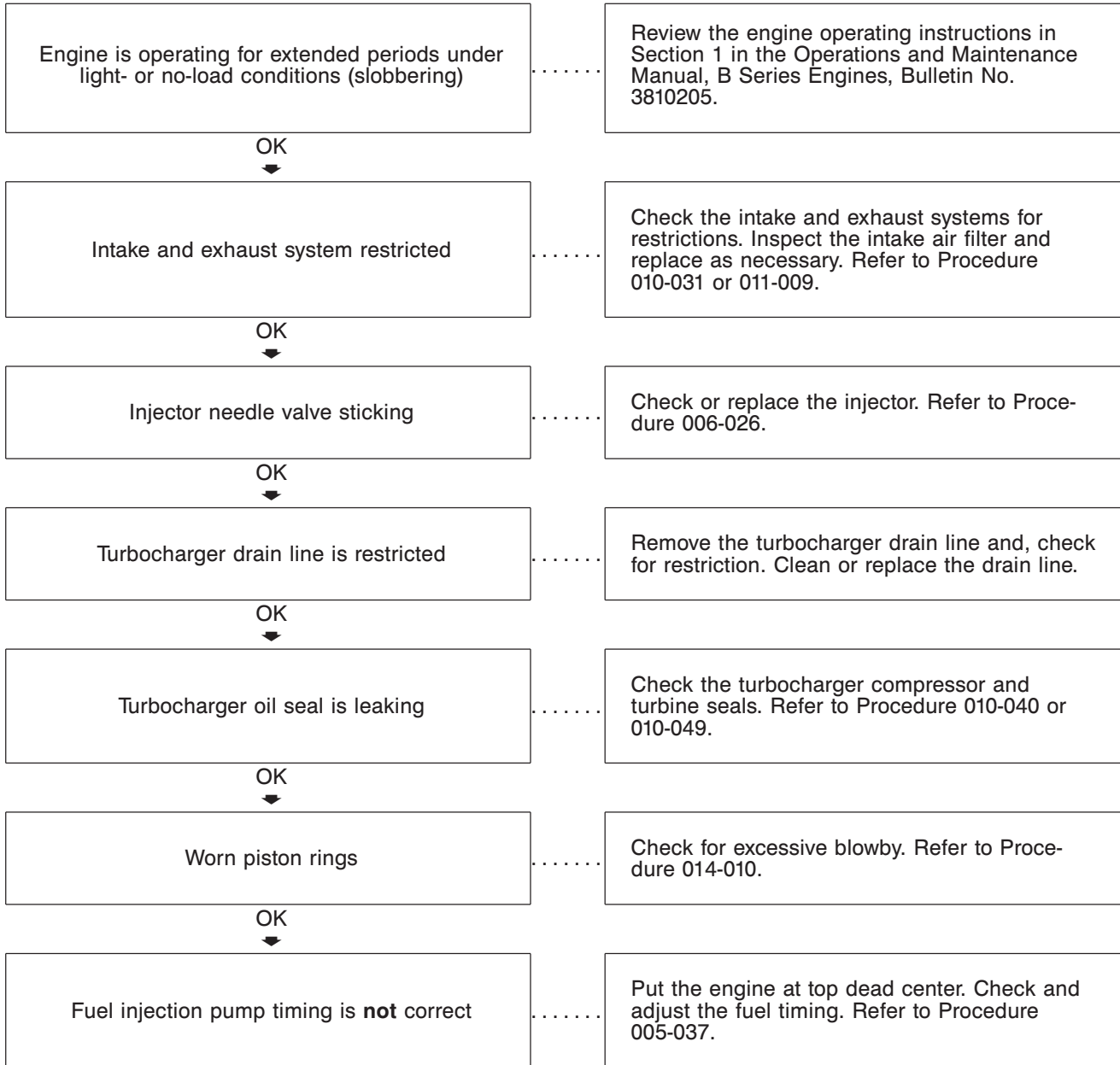

### Lubricating Oil Consumption Excessive

This is symptom tree T102.

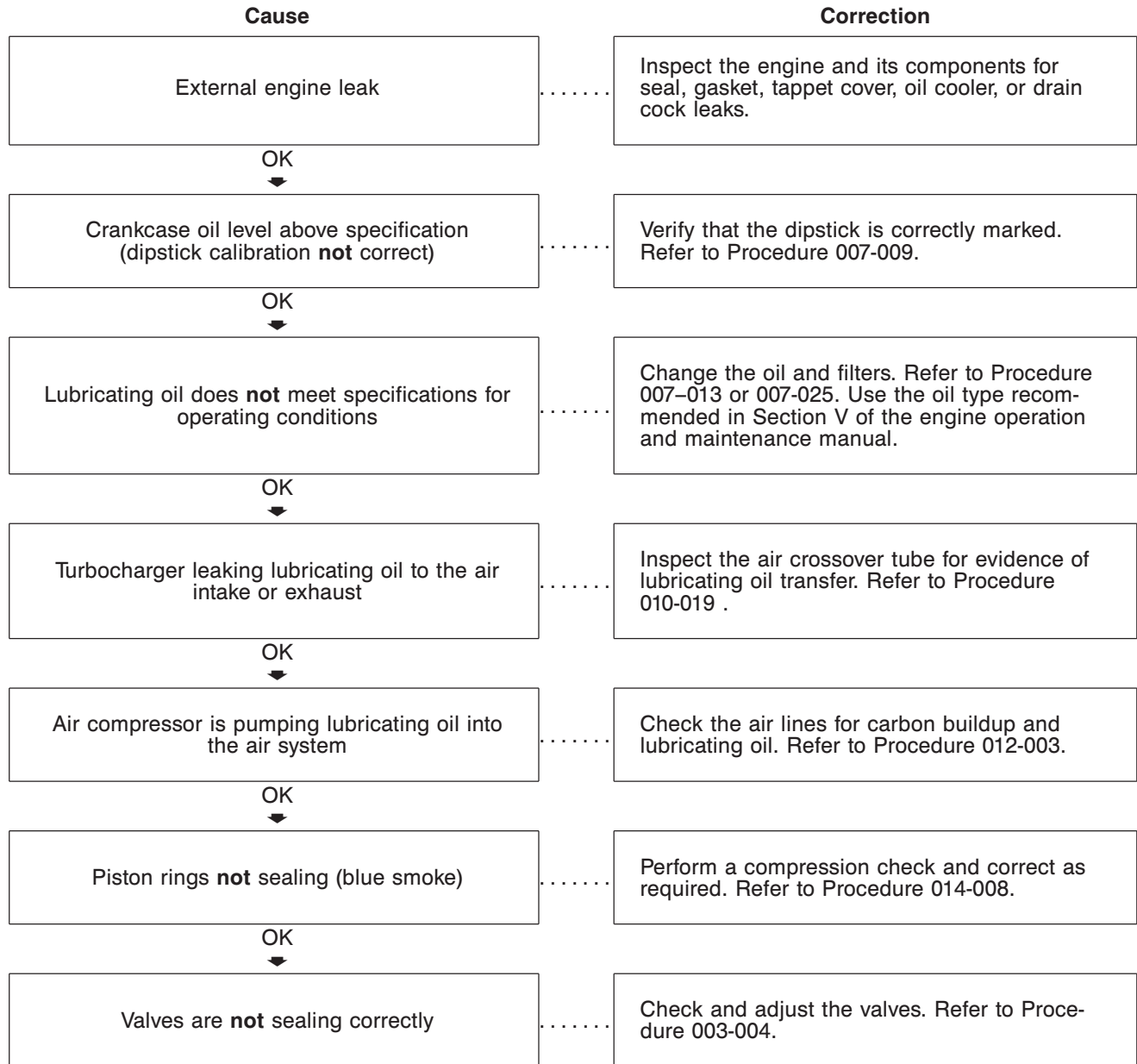

### Lubricating Oil Contaminated

This is symptom tree T103.

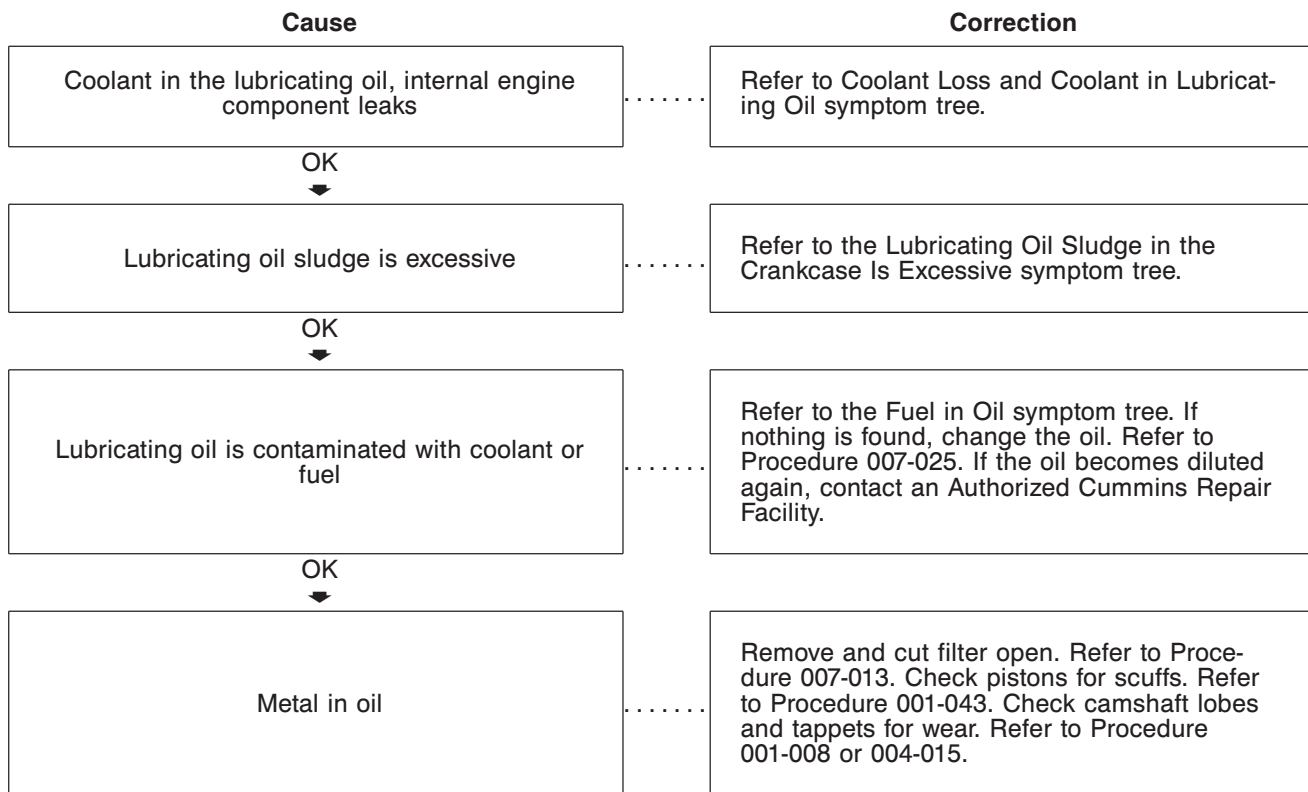

### Lubricating Oil Pressure High

This is symptom tree T104.

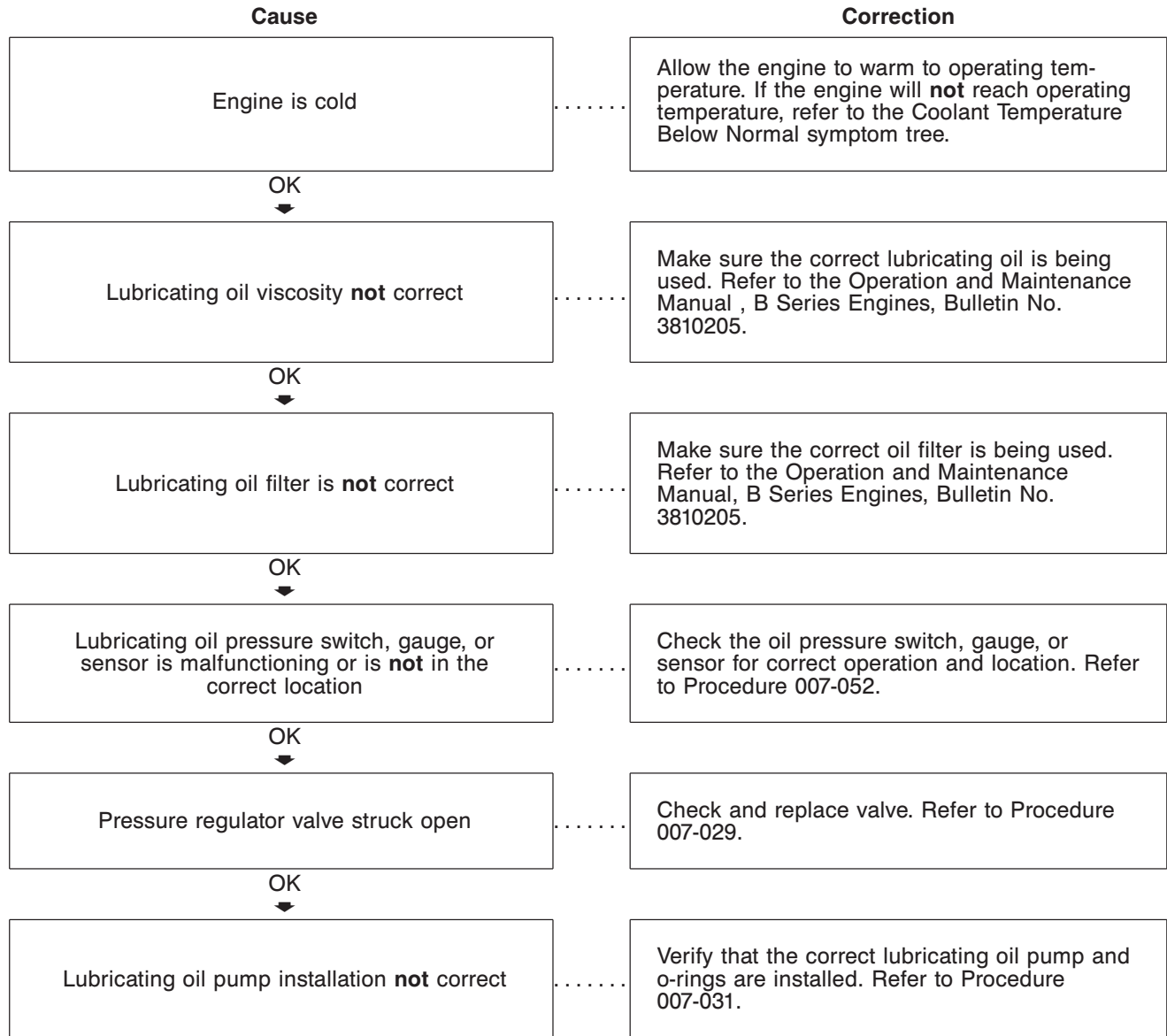

### Lubricating Oil Pressure Low

This is symptom tree T105.

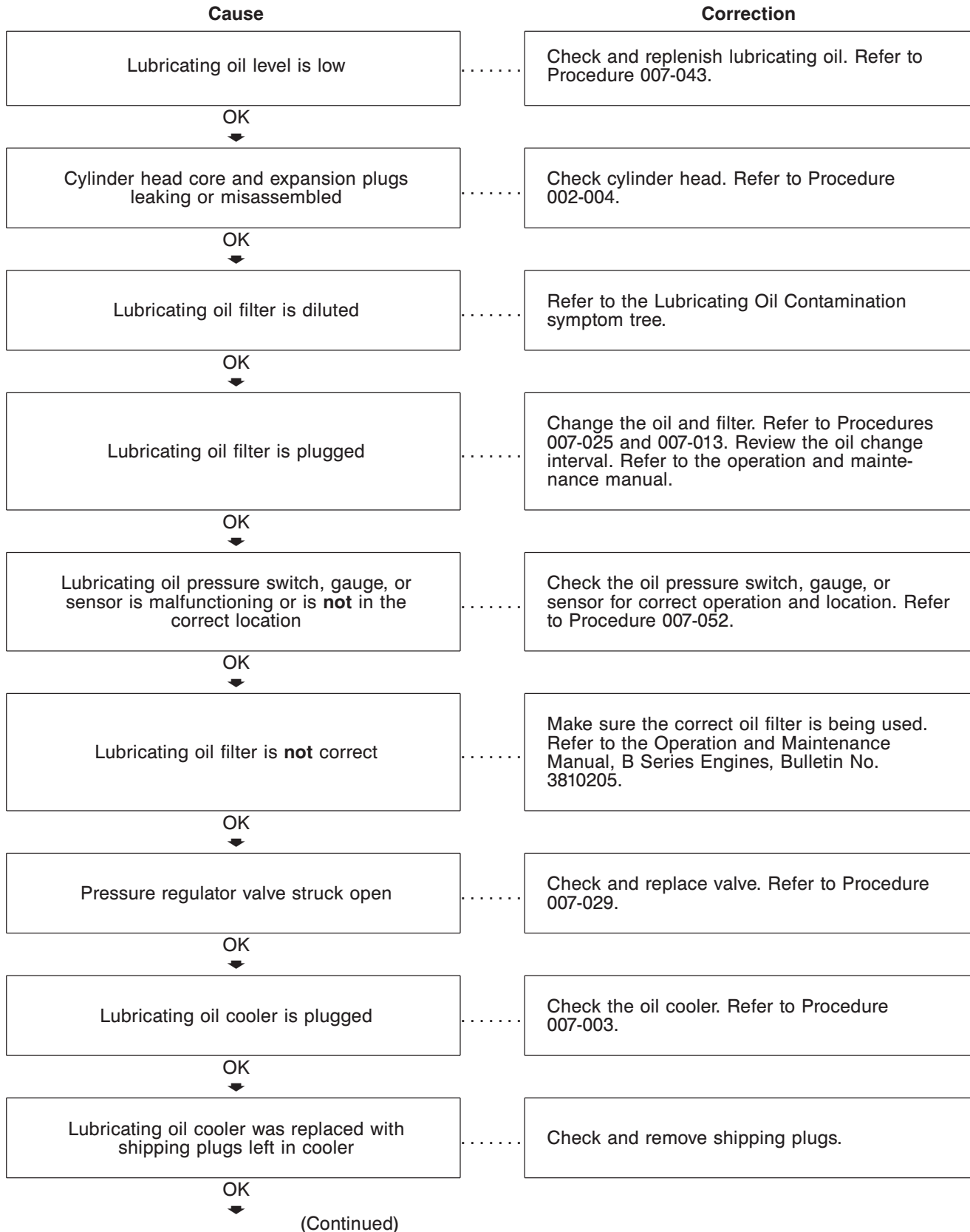



**Lubricating Oil Pressure Low (Continued)**

Cause	Correction
Lubricating oil pump is malfunctioning	Inspect the lubricating oil pump. Refer to Procedure 007-031.
OK ↓	
Lubricating oil suction or transfer tube is loose or broken, or the gasket or o-rings are leaking	Remove and inspect the oil pan or suction tube. Refer to Procedure 007-025.
OK ↓	
Main bearing capscrews are loose, worn, or <b>not</b> tightened correctly	Check the torque on the main bearing capscrews. Inspect the capscrews for wear. Refer to Procedure 001-006.
OK ↓	
Main bearings are damaged or worn, or the wrong bearings are installed	Inspect the main bearings for damage, excessive wear, and the correct part number. Refer to Procedure 001-006.
OK ↓	
Camshaft journals and No. 1 bushing are severely damaged	Inspect the camshaft journals and No. 1 bushing for wear. Refer to Procedure 001-008 or 001-010.

### Lubricating Oil Sludge in the Crankcase Excessive

This is symptom tree T106.

**Cause**

**Correction**

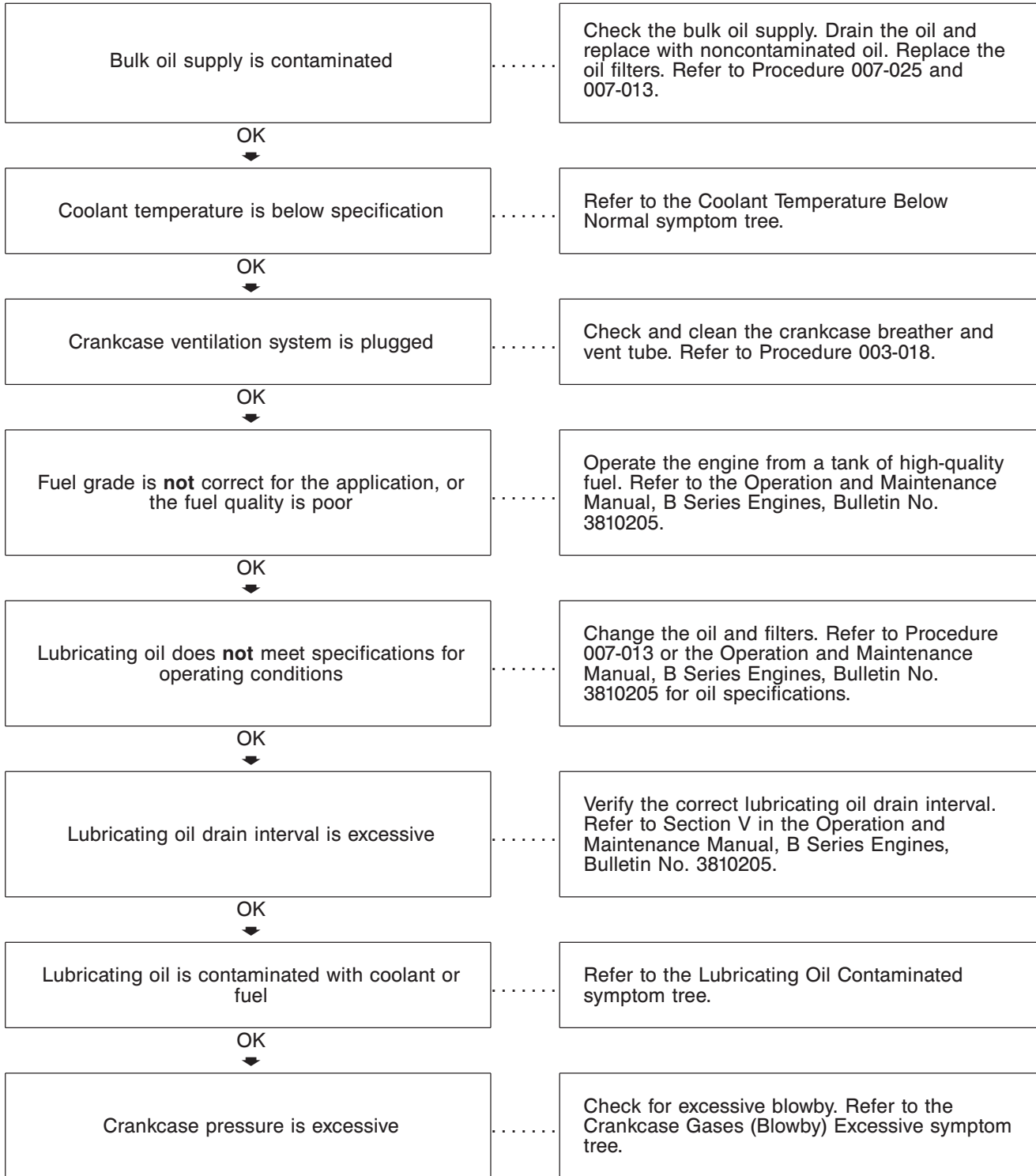

### Lubricating Oil Temperature Above Specification

This is symptom tree T107.

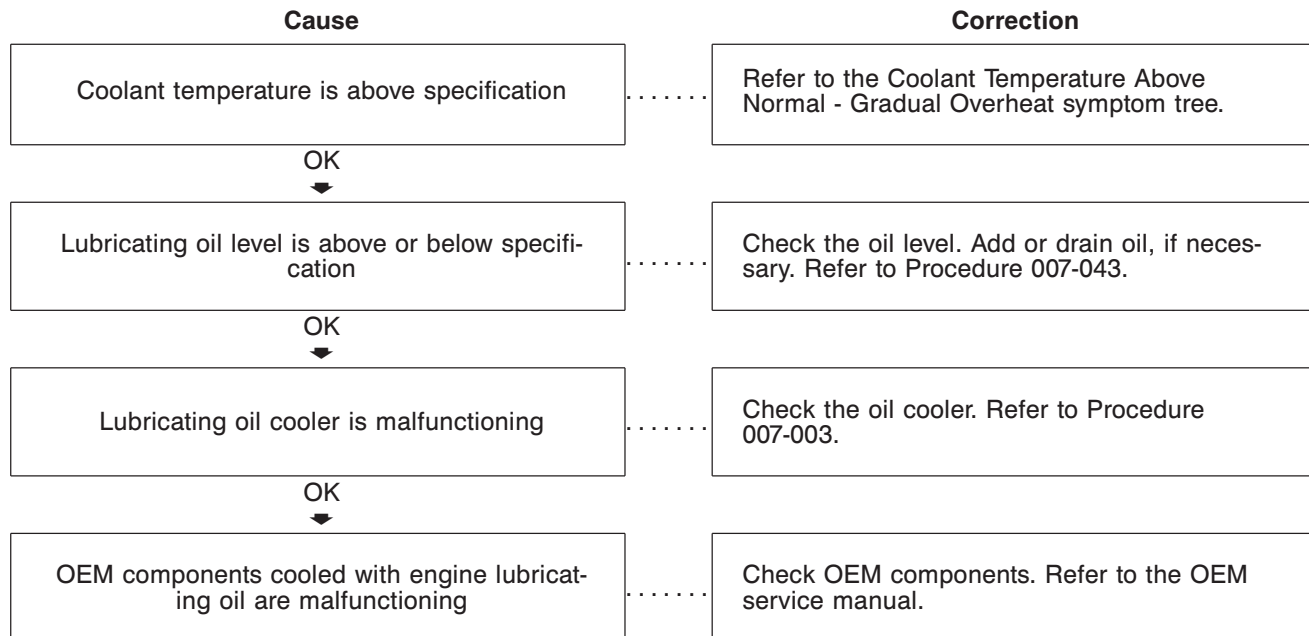

### Lubricating or Transmission Oil in the Coolant

This is symptom tree T108.

**Cause**

**Correction**

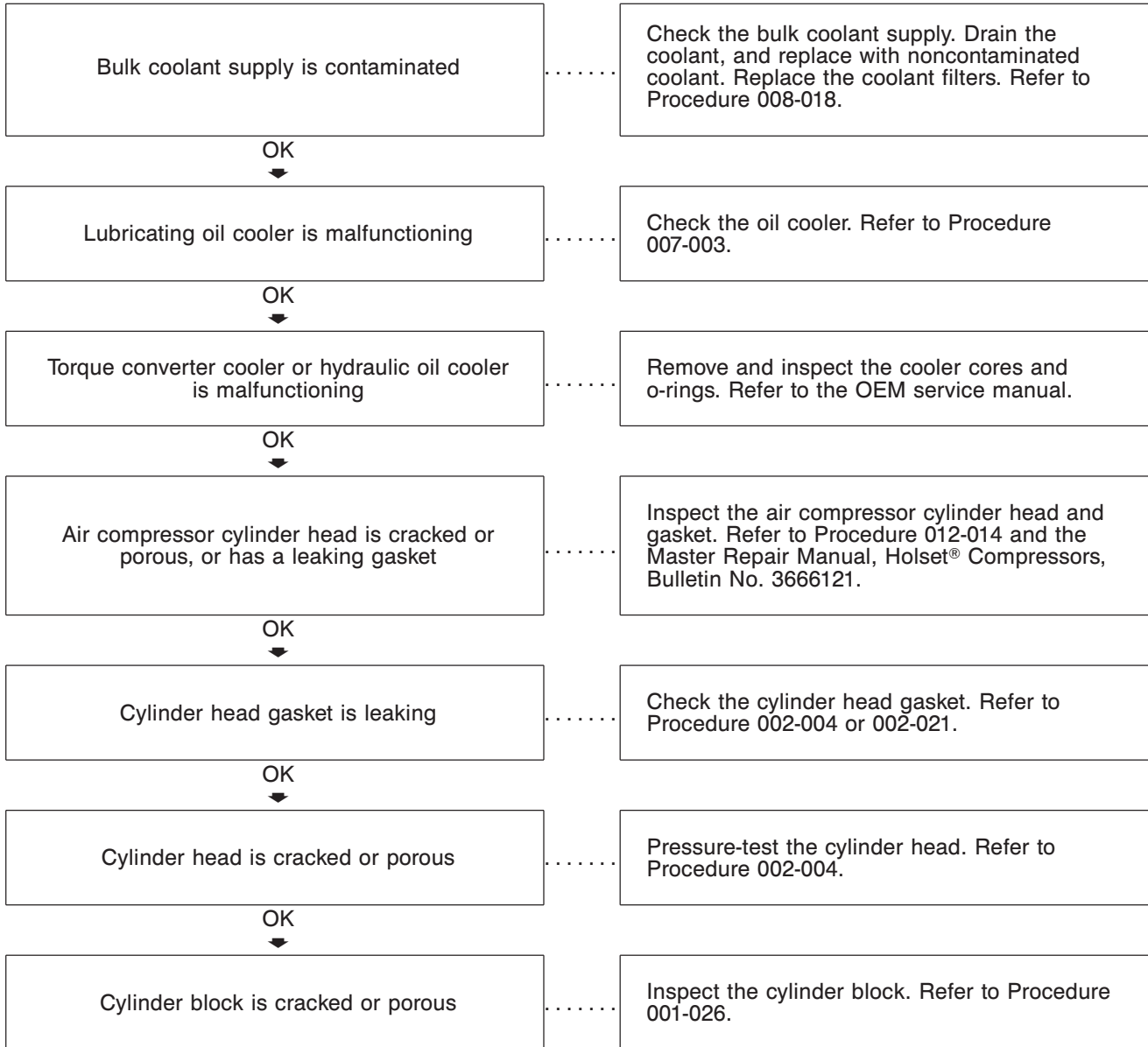

**Smoke, Black — Excessive**

This is symptom tree T116.

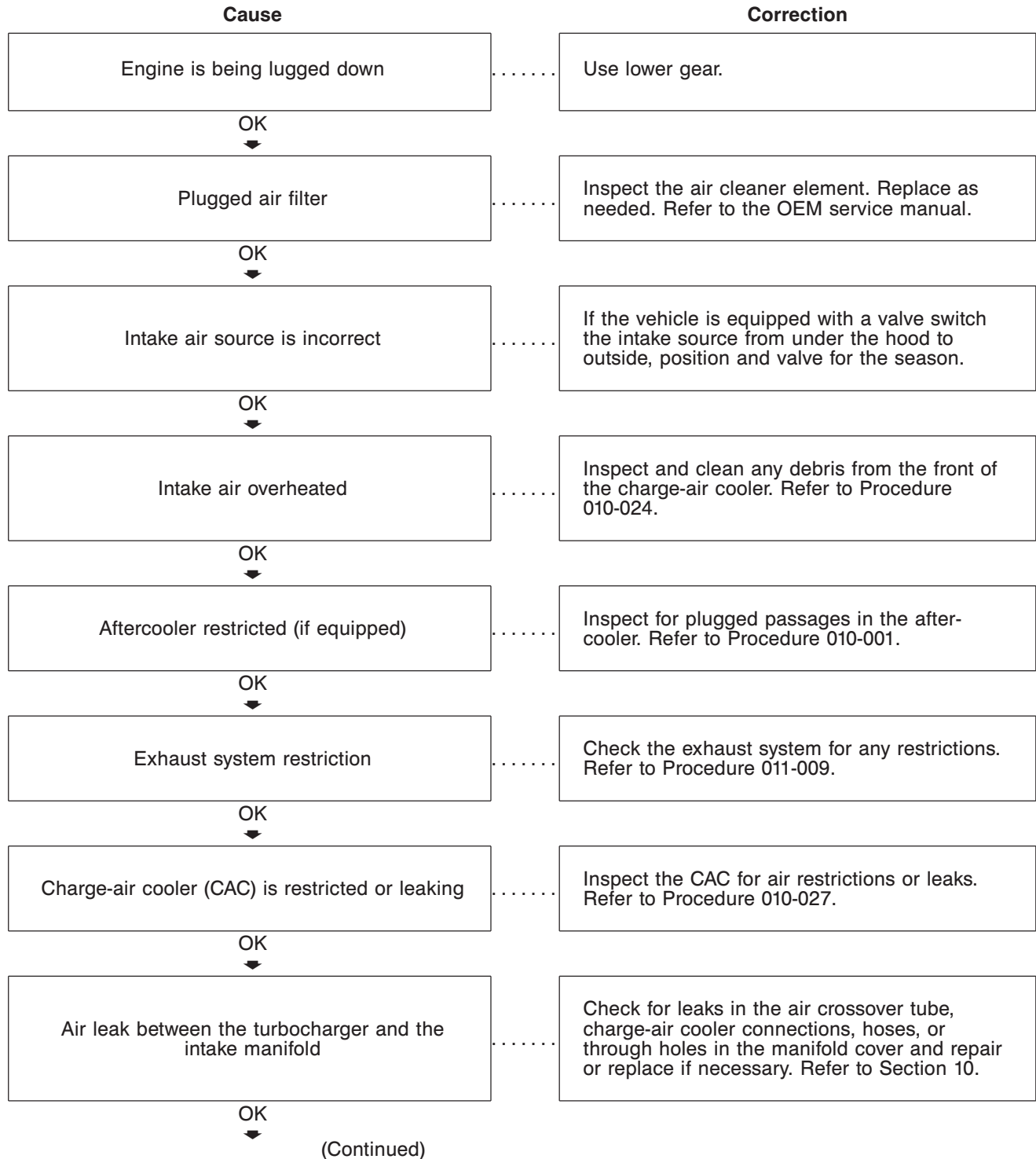

Smoke, Black — Excessive (Continued)

Cause

Correction

Exhaust leaks at the manifold or turbocharger	Check and correct any leaks in the exhaust manifold or turbocharger gaskets. Check for a cracked exhaust manifold. Refer to Procedure 011-007.
OK ↓	
Turbocharger wastegate is malfunctioning (if equipped)	Check the wastegate for correct operation. Refer to Procedure 010-050.
OK ↓	
Turbocharger is worn or malfunctioning	Check for the specified boost pressure. Inspect the turbocharger. Replace if necessary. Refer to Procedure 010-033.
OK ↓	
Injectors worn or malfunctioning	Remove and test the injectors. Replace as necessary. Refer to Procedure 006-026.
OK ↓	
Injector sealing washer <b>not</b> correct	Remove the injector. Check for extra sealing washer is installed under the injector. Check for proper sealing washer, and remove any additional sealing washer(s). <b>Only</b> one is required. Refer to Procedure 006-026.
OK ↓	
Fuel injection pump timing is <b>not</b> correct	Put the engine at top dead center. Check and adjust the fuel timing. Refer to Procedure 005-037.
OK ↓	
Fuel injection pump is malfunctioning	Remove the fuel injection pump. Check the calibration of the fuel injection pump. Refer to Procedure 005-012 or 005-014.
OK ↓	
Piston rings <b>not</b> sealing (blue smoke)	Perform a compression check and correct as required. Refer to Procedure 014-008.

**Smoke, White — Excessive**

This is symptom tree T118.

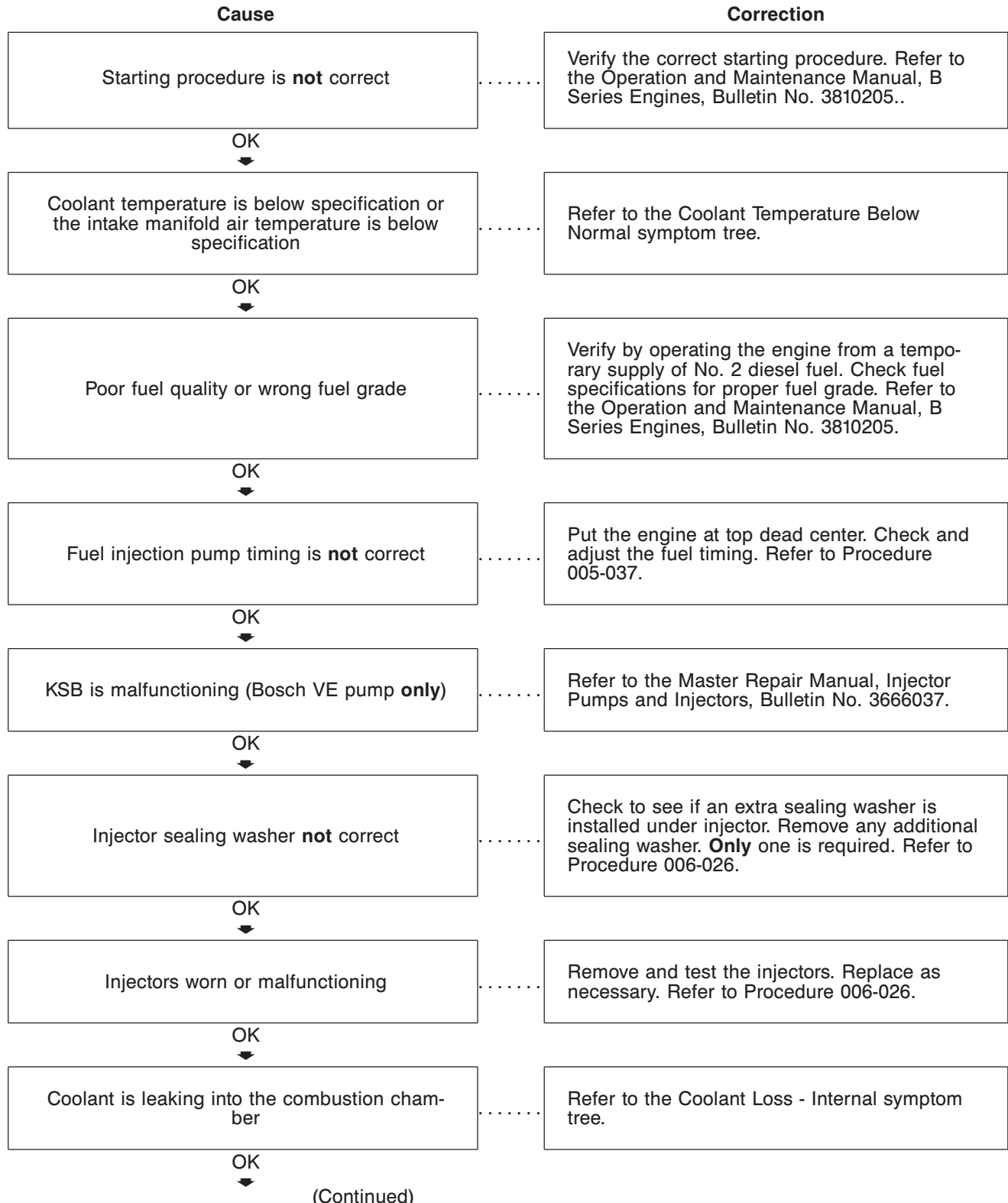

(Continued)

**Smoke, White — Excessive (Continued)**

**Cause**

**Correction**

Fuel injection pump is malfunctioning

.....

Remove the fuel injection pump. Check the calibration of the fuel injection pump. Refer to Procedure 005-012 or 005-014.



# Section 0 - Complete Engine - Group 00

## Section Contents

	<b>Page</b>
<b>Complete Engine - General Information</b> .....	0-2
<b>Engine Installation</b> .....	0-5
<b>Engine Painting</b> .....	0-9
<b>Engine Removal</b> .....	0-2
<b>Service Tools</b> .....	0-1
Engine Disassembly and Assembly .....	0-1

**THIS PAGE LEFT INTENTIONALLY BLANK**

## Service Tools

### Engine Disassembly and Assembly

The following special tools are recommended to perform procedures in this section. The use of these tools is shown in the appropriate procedure. These tools can be purchased from your local Cummins Authorized Repair Location.

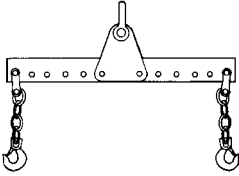
Tool No.	Tool Description	Tool Illustration
3822512	<b>Engine Lifting Fixture</b> Used to remove and install the engine.	 <p style="text-align: right; font-size: small;">3822512</p>

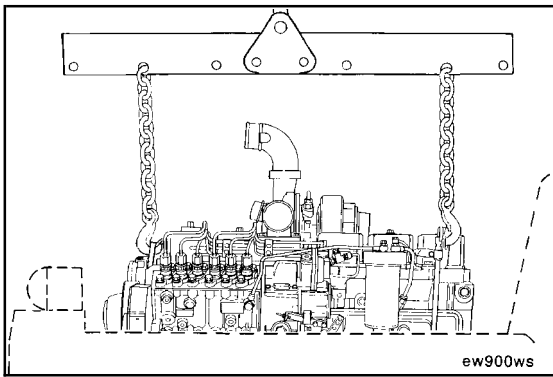

## Complete Engine - General Information

The procedures required to replace an engine will vary with different engine models, type of equipment, optional equipment, and shop facilities. Use the following procedures as a guide.

**NOTE:** All replacement steps will **not** apply to all equipment. Complete **only** the steps that apply to the equipment involved. Use the equipment manufacturer's recommendations and precautions for removal of chassis parts to gain access to the engine.

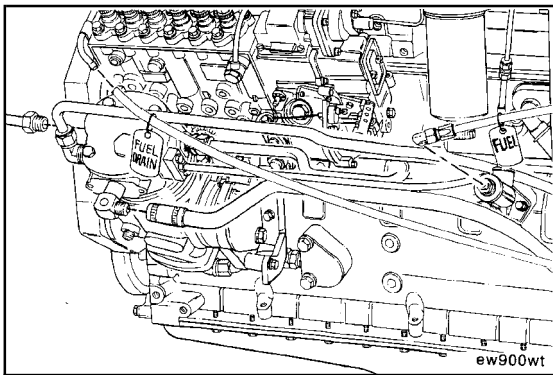

## Engine Removal (000-001)

Place a tag on all hoses, lines, linkage, and electrical connections as they are removed to identify their locations.

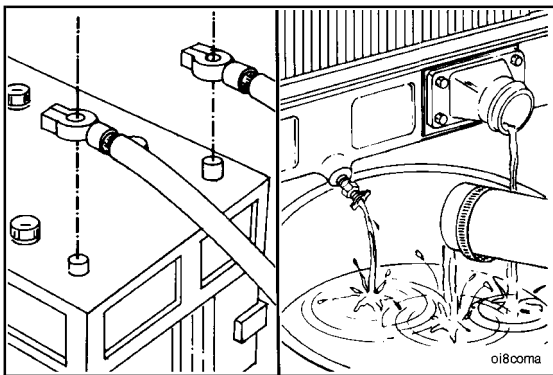

### ▲ WARNING ▲

Batteries can emit explosive gases. To avoid personal injury, always ventilate the compartment before servicing the batteries. To avoid arcing, remove the negative (-) battery cable first, and attach the negative (-) battery cable last.



### ▲ WARNING ▲

Coolant is toxic. If not reused, dispose of in accordance with local environmental regulations.

Disconnect the battery cables.

Drain the engine coolant. Refer to Procedure 008-018.

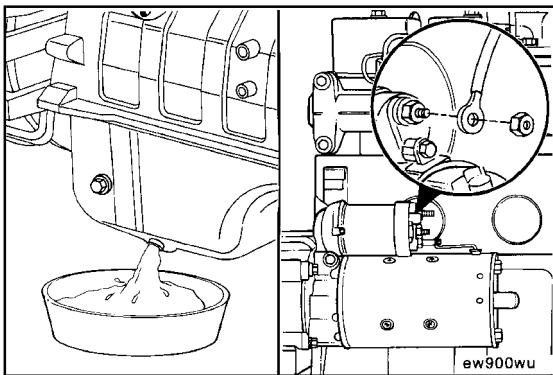

### ▲ WARNING ▲

Some state and federal agencies have determined that used engine oil can be carcinogenic and cause reproductive toxicity. Avoid inhalation of vapors, ingestion, or prolonged contact with used engine oil.



Drain the lubricating oil. Refer to Procedure 007-025.

Disconnect the starter cable, engine ground straps, cab- or chassis-to-engine hoses, tubing, electrical wires, and hydraulic lines.

**B3.9 and B5.9 Series Engines  
Section 0 - Complete Engine - Group 00**

Disconnect the intake and exhaust pipes.

Disconnect all chassis-mounted, engine-driven accessories.

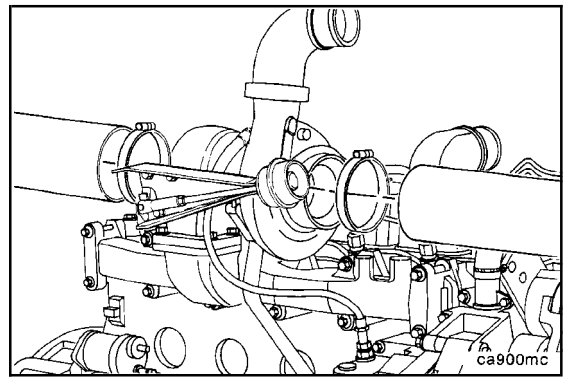

Disconnect the throttle linkage from the fuel injection pump control lever.

Disconnect the drive units from the flywheel.

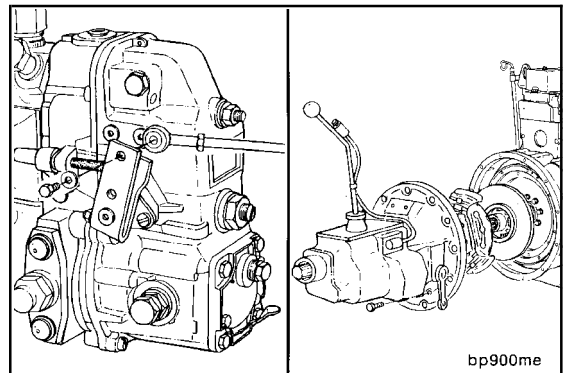

**⚠ WARNING ⚠**

If a liquid refrigerant system (air conditioning) is used, wear eye and face protection, and wrap a cloth around the fittings before removal. Liquid refrigerant can cause serious eye and skin injury.

**⚠ CAUTION ⚠**

To protect the environment, liquid refrigerant systems must be properly emptied and filled using equipment that prevents the release of refrigerant gas into the atmosphere. Federal law requires capturing and recycling the refrigerant.

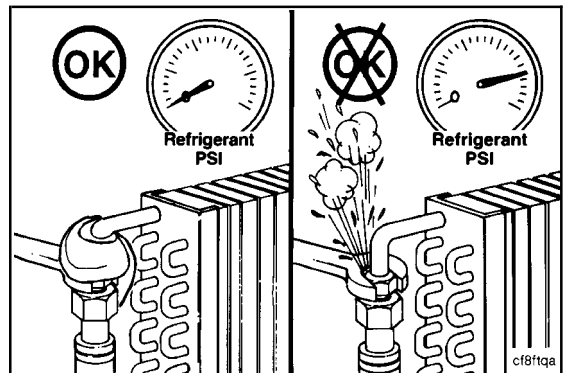

Remove all chassis components necessary to remove the engine from the equipment.

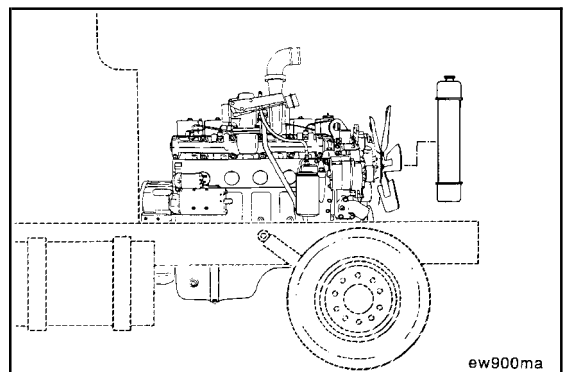

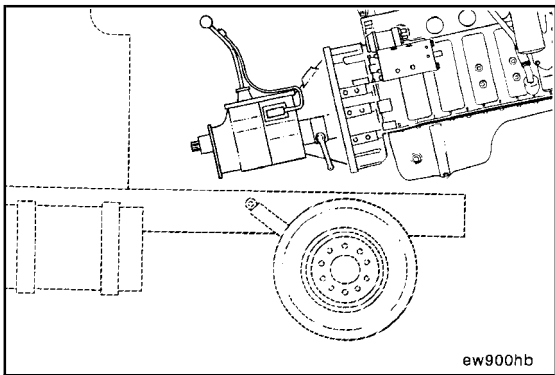

**WARNING**

The engine lifting equipment must be designed to lift the engine and transmission safely as an assembly without causing personal injury. The dry weight of the standard 6BTA5.9 without accessories is 411 kg [905 lb]. Refer to the equipment manufacturer's specifications for the transmission weight.

**NOTE:** On applications where the rear-engine mounts are attached to the transmission, it is often necessary to remove the engine and transmission as an assembly. Refer to the OEM service manual.

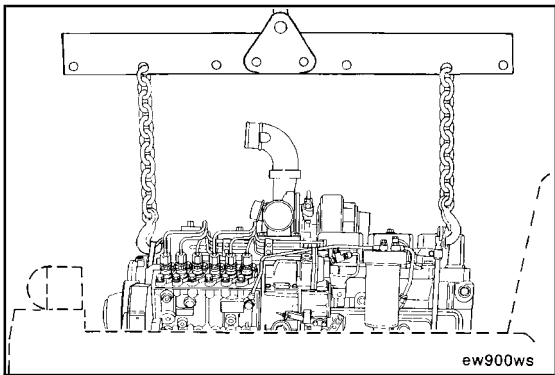

**Engine-Lifting Fixture, Part No. 3822512**

Use a properly rated hoist and engine-lifting fixture, Part No. 3822512, attached to the engine-mounted lifting brackets to remove the engine.



**NOTE:** If the transmission is **not** removed, place a support under the transmission to prevent it from falling.

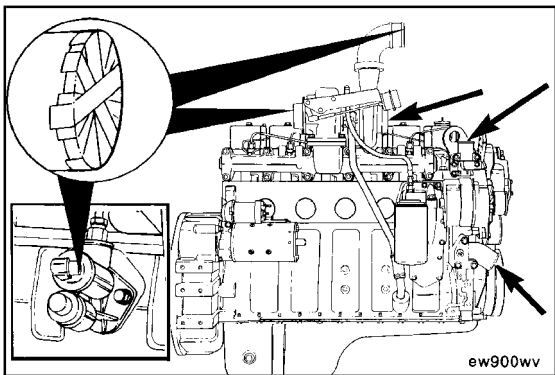

Cover all the engine openings to prevent dirt and debris from entering the engine.

Place the engine on suitable engine-support stands.

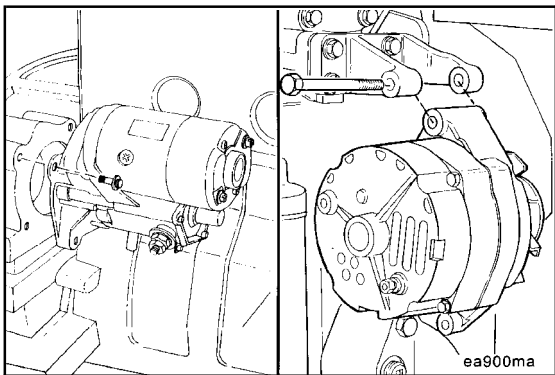

Remove all the remaining accessories and brackets to use with the replacement engine.

### Engine Installation (000-002)

Install all the accessories and brackets that were removed from the previous engine.

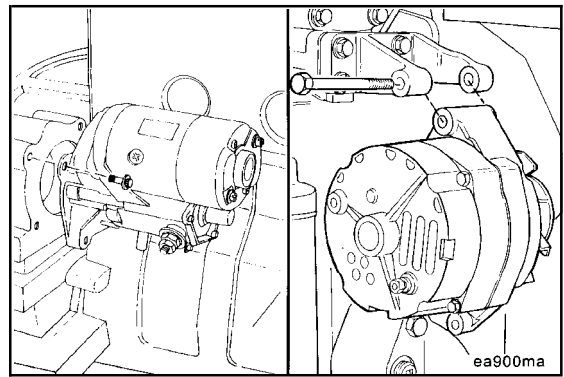

#### WARNING

The engine lifting equipment must be designed to lift the engine and transmission safely as an assembly without causing personal injury. The dry weight of the standard 6BTA5.9 without accessories is 411 kg [905 lb]. Refer to the equipment manufacturer's specifications for the transmission weight.

**NOTE:** On applications where the rear-engine mounts are attached to the transmission, it is often necessary to install the engine and transmission as an assembly. Refer to the OEM service manual.

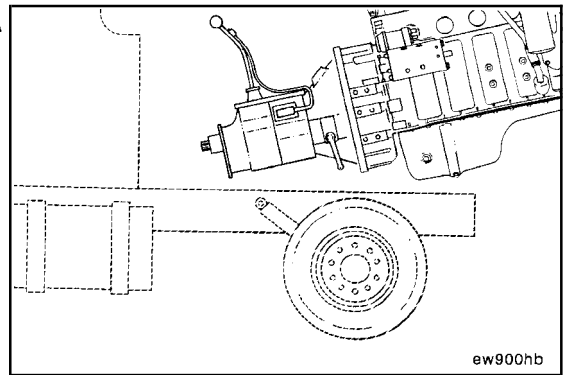

#### Engine-Lifting Fixture, Part No. 3822512

Use a properly rated hoist and engine-lifting bracket, Part No. 3822512, attached to the engine-mounted lifting brackets to install the engine.

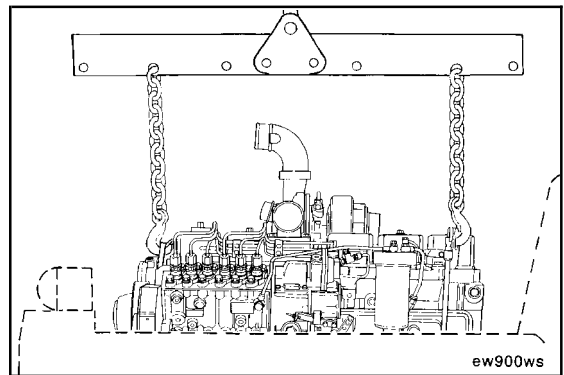

Align the engine in the chassis, and tighten the engine-mounting capscrews. Refer to the equipment manufacturer's torque specifications.

Connect all engine- and chassis-mounted accessories that were removed.

**NOTE:** Make sure that all lines, hoses, and tubes are properly routed and fastened to prevent damage. Make sure that the air intake and exhaust pipe connections are tight and free of leaks.

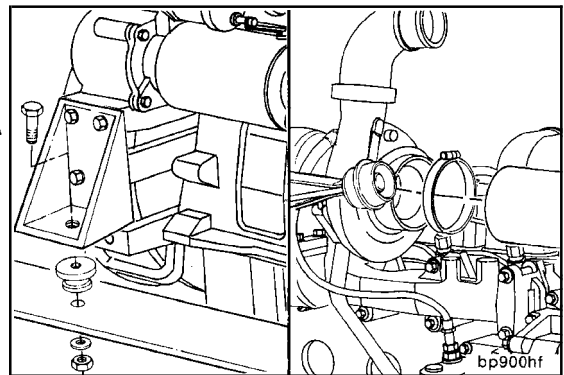

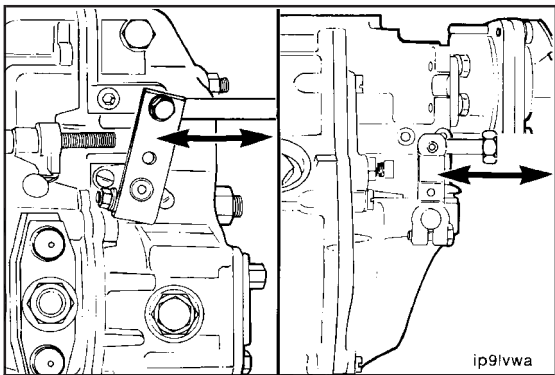

**Throttle Control Lever Connection**

Install and adjust the throttle linkage to the injection pump control lever. Refer to the OEM service manual.

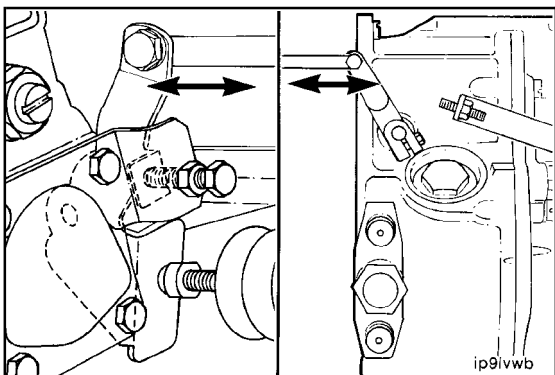

Adjust the length of the cable/rod to the mechanical shut-down lever so there is stop-to-stop movement. Refer to the OEM service manual.

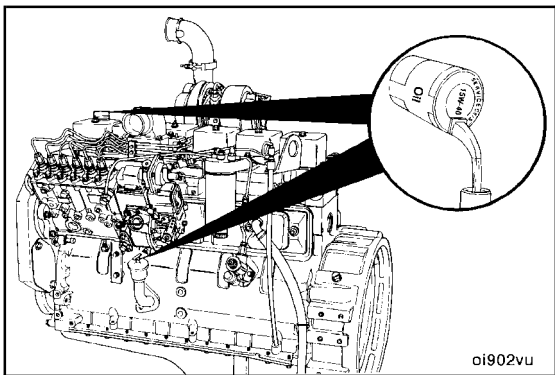

Fill the engine with clean lubricating engine oil.

**NOTE:** The total oil system capacity, including lubricating oil filters, is as follows:

	Liters	Qt
Four-Cylinder	11.0	11.6
Six-Cylinder	16.4	17.3
Optional Six-Cylinder	12.6	13.3
Optional Six-Cylinder (Ford)	18.9	20.0

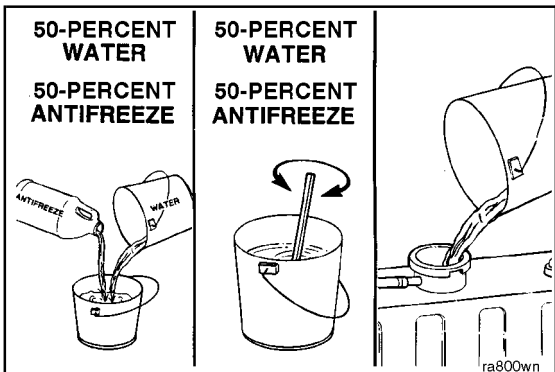

Fill the cooling system with a premixture of 50-percent water, 50-percent ethylene glycol-based antifreeze, and DCA4 corrosion protection. Refer to Procedure 008-018.

**NOTE:** The total coolant capacity (engine only) is as follows:

	Liters	Qt
Four-Cylinder	7	7.4
Four-Cylinder (Water Aftercooled)	9.7	10.3
Six-Cylinder	10.5	11.1
Six-Cylinder (Water Aftercooled)	14.5	15.3



**NOTE:** Refer to the OEM specifications for the radiator and system capacity.

**▲ CAUTION ▲**

Installation of the radiator cap at this point is critical to proper purging of air trapped in the cooling system. Improper purging of air from the cooling system can result in engine damage from overheating.

Perform a final inspection to make sure that all hoses, wires, linkages, and components have been properly installed and tightened.

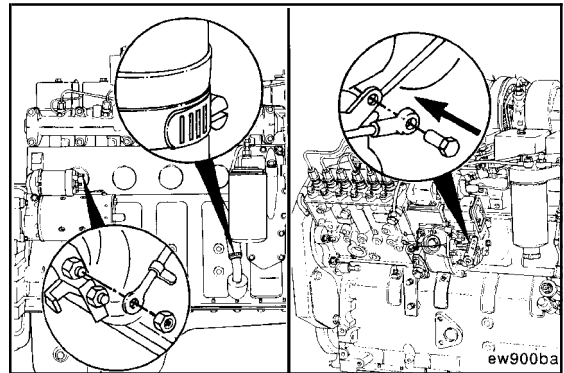

Make sure that the fuel is shut off by removing the wire from the fuel solenoid or by verifying that the mechanical fuel shutoff is in the OFF position. This is necessary to prevent the engine from starting during the lubricating oil rifle pressure charging operation.

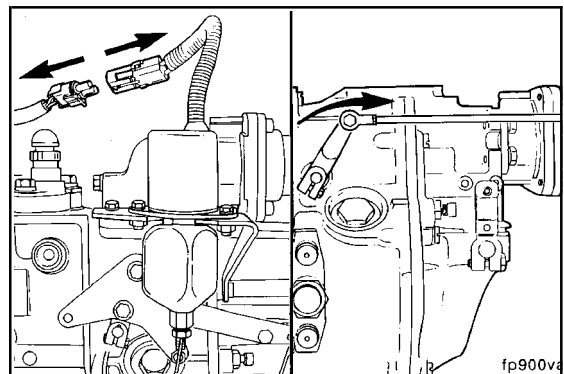

**▲ CAUTION ▲**

Do not engage the starting motor for more than 30 seconds. Wait 2 minutes between starter engagements to cool the starting motor.

Crank the engine until the lubricating oil pressure gauge indicates a positive pressure.

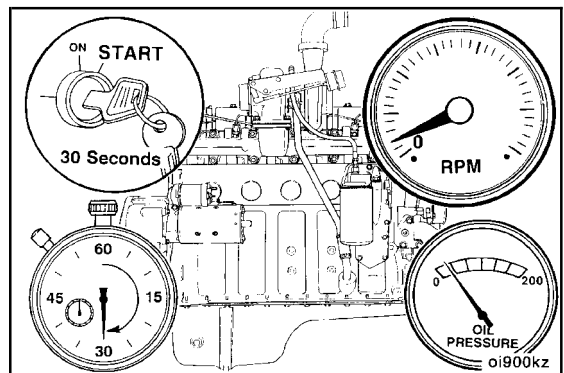

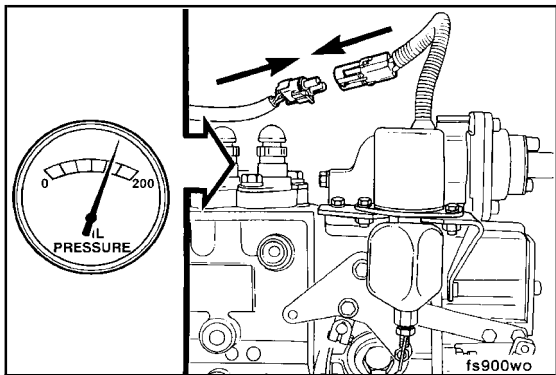

After pressure is observed, connect the wire to the fuel solenoid.

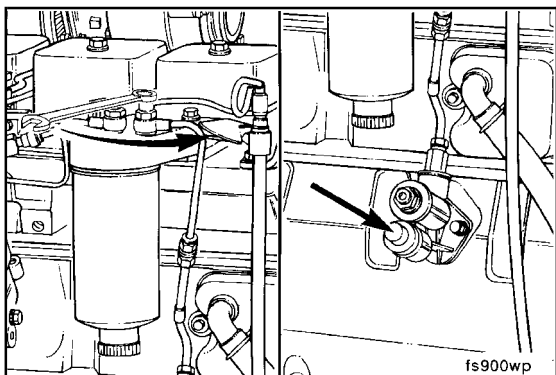

Prime the low-pressure fuel system by opening the bleed screw.

Operate the plunger on the fuel transfer pump until the fuel flowing from the fitting is free of air.

Tighten the bleed screw.

**Torque Value:** 9 N•m [80 in-lb]

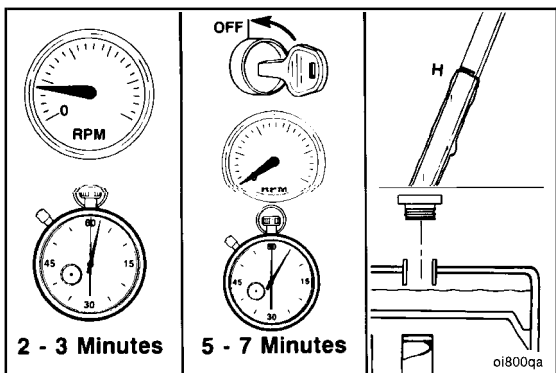

**▲ WARNING ▲**

**Do not remove the radiator cap from a hot engine. Hot steam can cause serious personal injury. The engine coolant temperature must be below 50°C [122°F].**

Operate the engine at low idle for 2 to 3 minutes.

Shut off the engine, and wait 5 to 7 minutes for the lubricating oil to drain to the lubricating oil pan, and check the lubricating oil and coolant levels again.

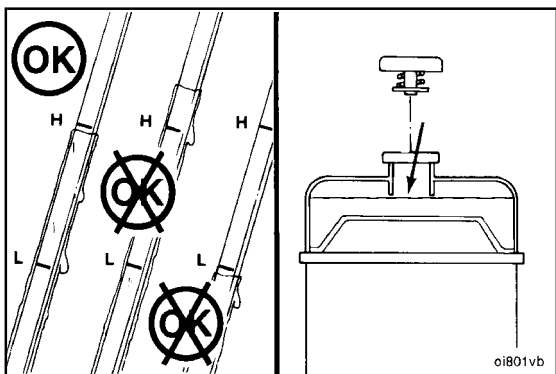

Fill the engine to the correct lubricating oil and coolant levels, if necessary.

**B3.9 and B5.9 Series Engines  
Section 0 - Complete Engine - Group 00**

Operate the engine at 1000 to 1200 rpm for 8 to 10 minutes. Check for proper operation, unusual noises, and coolant, fuel, or lubricating oil leaks.



Repair all leaks and component problems. Refer to the appropriate procedures.



Refer to Section 14 for the Engine Run-in and Test Procedures.

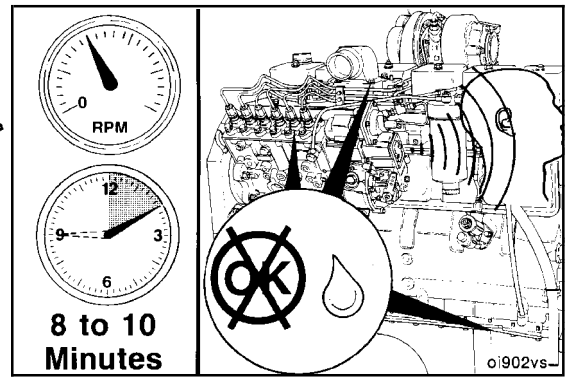

**Engine Painting (000-007)**

Remove all the belts from the engine.



Cover the following parts of the engine:

- All pulley belt surfaces
- Exhaust and intake openings
- Electrical components
- Fuel inlet and drain connections
- Any exposed fittings, threads, and electrical wire terminals.

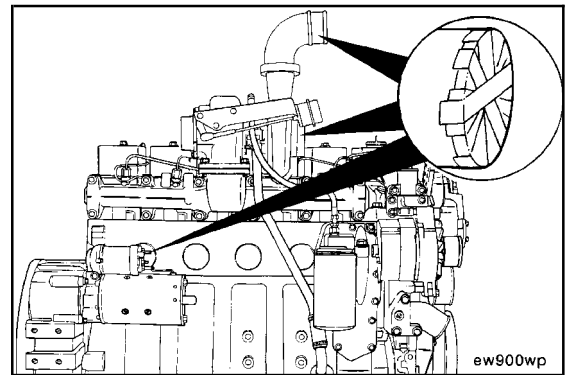

**⚠ WARNING ⚠**

When using a steam cleaner, wear protective clothing and safety glasses or a face shield. Hot steam can cause serious personal injury.



Use steam to clean the engine, and dry with compressed air.

Avoid prolonged, direct steam or water spray on electrical components.

**NOTE:** Make sure that all engine surfaces are clean and dry before painting the engine.

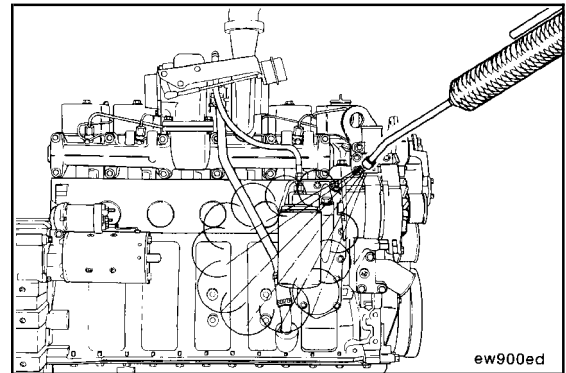

Protect the following components from the paint:

- All dataplates
- Valve and injector set marks
- Exhaust manifold
- Turbocharger turbine housing
- Flywheel
- Flywheel housing transmission mounting surface.

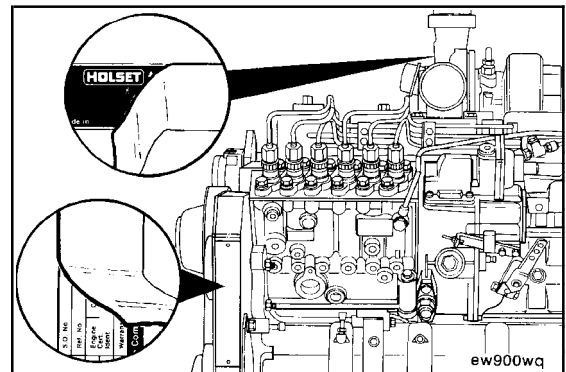

Paint the engine.

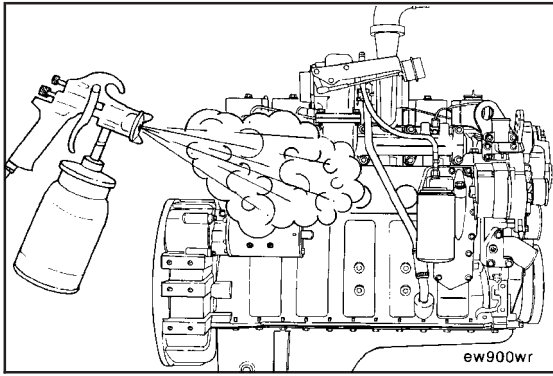

# Section 1 - Cylinder Block - Group 01

## Section Contents

	Page
<b>Bearings, Connecting Rod</b> .....	1-5
Clean .....	1-8
General Information .....	1-5
Inspect for Reuse .....	1-8
Install .....	1-9
Preparatory .....	1-6
Remove .....	1-6
<b>Bearings, Main</b> .....	1-12
Clean .....	1-15
General Information .....	1-12
Inspect for Reuse .....	1-15
Install .....	1-17
Measure .....	1-16
Preparatory .....	1-13
Remove .....	1-13
<b>Camshaft</b> .....	1-20
Clean .....	1-24
General Information .....	1-20
Inspect for Reuse .....	1-24
Install .....	1-31
Preparatory .....	1-22
Remove .....	1-22
<b>Camshaft Bushings</b> .....	1-34
Initial Check .....	1-34
Install .....	1-35
Measure .....	1-36
Remove .....	1-34
<b>Camshaft Gear (Camshaft Removed)</b> .....	1-36
Clean .....	1-37
Inspect for Reuse .....	1-37
Install .....	1-38
Preparatory .....	1-36
Remove .....	1-36
<b>Connecting Rod</b> .....	1-40
Clean .....	1-41
Inspect for Reuse .....	1-41
Install .....	1-44
Preparatory .....	1-40
Remove .....	1-41
Test .....	1-44
<b>Crankshaft</b> .....	1-45
Clean .....	1-48
General Information .....	1-45
Inspect for Reuse .....	1-48
Install .....	1-50
Preparatory .....	1-46
Remove .....	1-47
Rotation Check .....	1-53
<b>Crankshaft Gear, Front (Crankshaft Installed)</b> .....	1-54
General Information .....	1-54
<b>Crankshaft Seal, Front</b> .....	1-54
Clean .....	1-55
General Information .....	1-54
Inspect for Reuse .....	1-55
Install .....	1-56
Remove .....	1-54
<b>Crankshaft Seal, Rear</b> .....	1-57
Clean .....	1-58

	Page
Install .....	1-58
Preparatory.....	1-57
Remove.....	1-58
<b>Crankshaft Wear Sleeve, Front</b> .....	1-59
Clean .....	1-60
Inspect for Reuse .....	1-61
Install .....	1-61
Preparatory.....	1-59
Remove.....	1-60
<b>Crankshaft Wear Sleeve, Rear</b> .....	1-109
Clean .....	1-111
General Information .....	1-109
Inspect for Reuse .....	1-111
Install.....	1-112
Preparatory .....	1-109
Remove.....	1-110
<b>Cylinder Block</b> .....	1-63
Assemble .....	1-67
Clean .....	1-66
Disassemble.....	1-65
General Information .....	1-63
Inspect for Reuse .....	1-67
Preparatory.....	1-65
<b>Engine Dataplate</b> .....	1-108
Install.....	1-108
Remove .....	1-108
<b>Gear Cover, Front</b> .....	1-68
Clean .....	1-69
Inspect for Reuse .....	1-70
Install .....	1-70
Remove.....	1-68
<b>Gear Housing, Front</b> .....	1-72
Clean .....	1-74
General Information .....	1-72
Inspect for Reuse .....	1-75
Install .....	1-76
Preparatory.....	1-73
Remove.....	1-73
<b>Piston</b> .....	1-78
Clean.....	1-81
General Information .....	1-78
Inspect for Reuse .....	1-82
Install .....	1-86
Preparatory.....	1-79
Remove.....	1-80
Test .....	1-83
<b>Piston and Connecting Rod Assembly</b> .....	1-95
Assemble .....	1-99
Disassemble.....	1-98
General Information .....	1-95
Install.....	1-103
Remove.....	1-96
<b>Piston Rings</b> .....	1-86
General Information .....	1-86
Inspect for Reuse .....	1-86
Install .....	1-88
Measure .....	1-87
<b>Service Tools</b> .....	1-1
Cylinder Block.....	1-1
<b>Timing Pin Housing</b> .....	1-90
Install .....	1-90

	<b>Page</b>
Preparatory.....	1-90
Remove.....	1-90
<b>Vibration Damper</b> .....	1-91
General Information .....	1-91
Inspect for Reuse .....	1-92
Install .....	1-94
Measure .....	1-93
Preparatory.....	1-91
Remove .....	1-91

**THIS PAGE LEFT INTENTIONALLY BLANK**



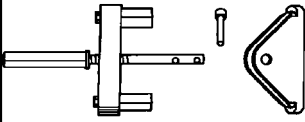
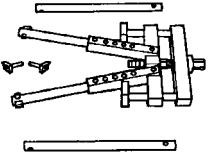
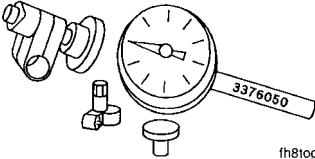
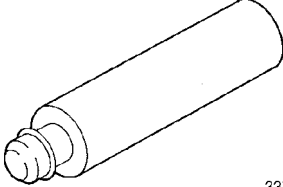
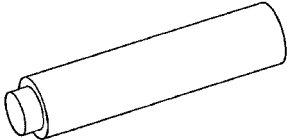

## Service Tools Cylinder Block

The following special tools are recommended to perform procedures in this section. The use of these tools is shown in the appropriate procedure. These tools can be purchased from your local Cummins Authorized Repair Location.

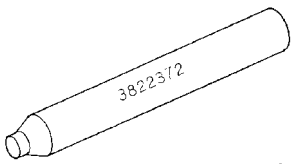
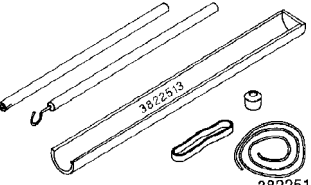
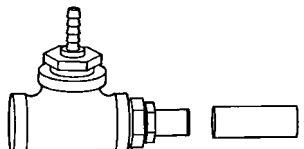
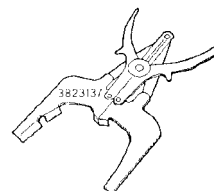
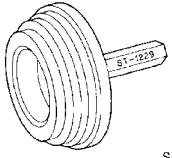
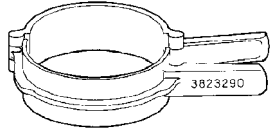
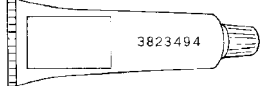
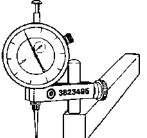
Tool No.	Tool Description	Tool Illustration
3375068	<p><b>Cup Plug Sealant</b></p> <p>Used when installing pipe and cup plugs on the engine to prevent leaks.</p>	 <p style="text-align: right;">bp8togk</p>
3375629	<p><b>Universal Cylinder Liner Puller</b></p> <p>Removes cylinder liners from cylinder block. Requires cylinder liner puller plate, Part No. 3822786.</p>	 <p style="text-align: right;">ck8togq</p>
3376015	<p><b>Universal Cylinder Liner Puller</b></p> <p>Removes the cylinder liners from the cylinder block. Require two puller arm extension feet, Part No. 3376649.</p>	 <p style="text-align: right;">ck8togr</p>
3376050	<p><b>Dial Indicator and Sleeve Assembly</b></p> <p>Used to measure flywheel and flywheel housing runout.</p>	 <p style="text-align: right;">fh8togc</p>
3376795	<p><b>Expansion Plug Driver Handle</b></p> <p>Used with all expansion plug drivers larger than 0.375-inch in diameter.</p>	 <p style="text-align: right;">3376795</p>
3376816	<p><b>Expansion Plug Driver</b></p> <p>Used to install a 1-inch expansion plug to specified depth. Used with expansion plug driver handle, Part No. 3376795.</p>	 <p style="text-align: right;">ck8togo</p>

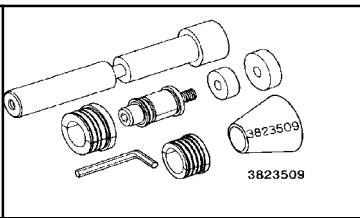
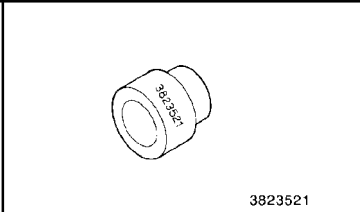
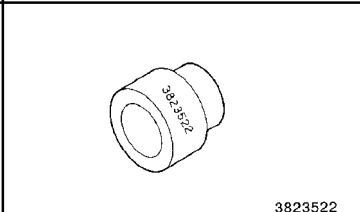
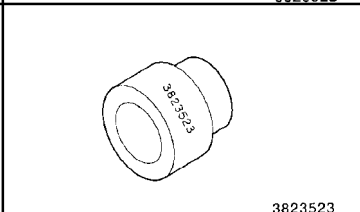
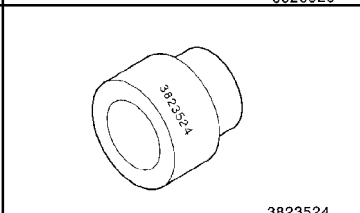
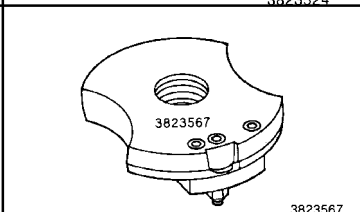
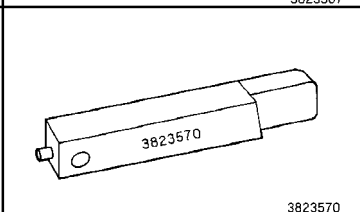
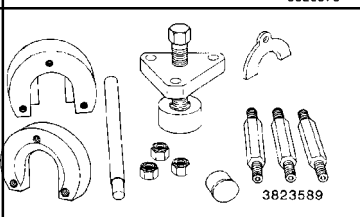
Tool No.	Tool Description	Tool Illustration
3822372	<p><b>Expansion Plug Driver</b></p> <p>Used to install a 0.375-inch expansion plug to specified depth. Used with expansion plug driver handle, Part No. 3376795.</p>	 <p>3822372</p>
3822513	<p><b>Tappet Removal Tool Kit</b></p> <p>Used to remove and install valve tappets.</p>	 <p>3822513</p>
3822566	<p><b>Blowby Check Tool</b></p> <p>Used with manometer, Part No. ST-1111-3, to measure the engine crankcase pressure.</p>	 <p>3822566</p>
3823137	<p><b>Piston Ring Expander</b></p> <p>Used to install piston rings onto pistons without damaging or distorting the rings.</p>	 <p>3823137</p>
3823230	<p><b>Cylinder Liner Driver</b></p> <p>Used to install the cylinder liner into the cylinder block.</p>	 <p>ST-1229</p>
3823290	<p><b>Piston Ring Compressor</b></p> <p>Used to compress the piston rings while installing the pistons into the cylinder bores.</p>	 <p>3823290</p>
3823494	<p><b>Sealant, Three-Bond™ (150-gram tube)</b></p> <p>Used for sealing tee joints and front gear cover.</p>	 <p>3823494</p>
3823495	<p><b>Gauge Block</b></p> <p>Used to measure cylinder liner protrusion on the cylinder block.</p>	 <p>3823495</p>

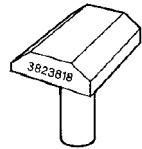
Tool No.	Tool Description	Tool Illustration
3823509	<p><b>Camshaft Bushing Tool</b> Used to remove camshaft bushings.</p>	
3823521	<p><b>Expansion Plug Driver</b> Used to install 0.8125-inch expansion plug to specified depth. Used with expansion plug driver handle, Part No. 3376795.</p>	
3823522	<p><b>Expansion Plug Driver</b> Used to install 1.1875-inch expansion plug to specified depth. Used with expansion plug driver handle, Part No. 3376795.</p>	
3823523	<p><b>Expansion Plug Driver</b> Used to install 1.375-inch expansion plug to specified depth. Used with expansion plug driver handle, Part No. 3376795.</p>	
3823524	<p><b>Expansion Plug Driver</b> Used to install 2.250-inch expansion plug to specified depth. Used with expansion plug driver handle, Part No. 3376795.</p>	
3823567	<p><b>Cutter Plate</b> Used with Part No. 3823558, cylinder liner counterbore tool.</p>	
3823570	<p><b>Cutter Bit</b> Used with Part No. 3826567, cutter plate, to machine the cylinder liner counterbore ledge.</p>	
3823589	<p><b>Camshaft Gear Installation/Removal Tool</b> Used to install/remove the camshaft gear without removing the camshaft from the engine.</p>	

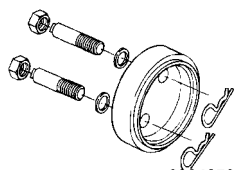
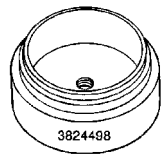
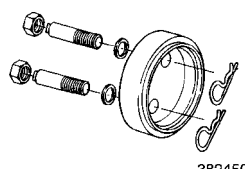
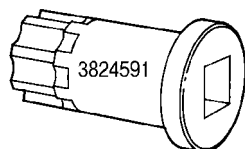
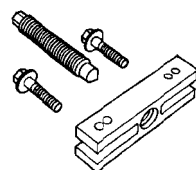
Tool No.	Tool Description	Tool Illustration
3823818	<p><b>Main Bearing Rollout Tool</b> Used to remove and install main bearings with the crankshaft installed.</p>	 <p style="text-align: right;">3823818</p>
3823921	<p><b>Capscrew Length Gauge</b> Used to measure capscrew free length.</p>	 <p style="text-align: right;">3823921</p>
3824078	<p><b>Wear Sleeve Installation Tool</b> Used to install the rear crankshaft lubricating oil seal wear sleeve.</p>	 <p style="text-align: right;">3824078</p>
3824499	<p><b>Oil Seal Installation Tool</b> Used to install the front crankshaft lubricating oil seal in the front cover to a specified depth.</p>	 <p style="text-align: right;">3824498</p>
3824500	<p><b>Wear Sleeve Installation Tool</b> Used to install the front crankshaft lubricating oil seal wear sleeve.</p>	 <p style="text-align: right;">3824500</p>
3824591	<p><b>Engine Barring Gear</b> Used to engage the flywheel ring gear to rotate the crankshaft.</p>	 <p style="text-align: right;">3824591</p>
ST-647	<p><b>Standard Puller</b> Used to remove drive pulleys, impellers, and air compressor counterweights.</p>	 <p style="text-align: right;">ad8toga</p>

## Bearings, Connecting Rod (001-005)

### General Information

In production, steel-backed aluminum connecting rod bearings are used for naturally aspirated engines. Steel-backed trimetal bearings are used in production for the additional loading, resulting from turbocharging and aftercooling.

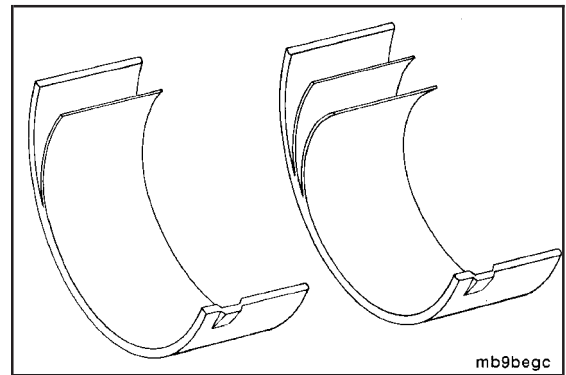

To prevent incorrect use of the two bearings at time of repair, **only** steel-backed trimetal bearings are available for service.

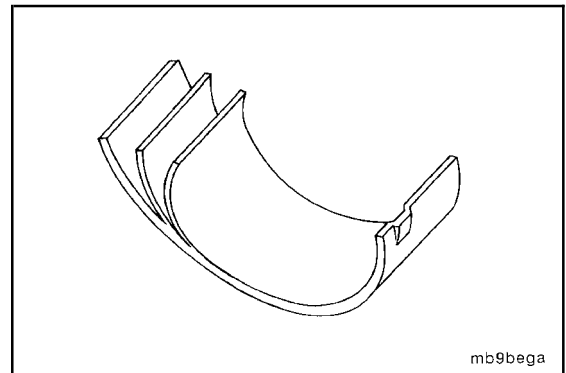

Improper maintenance of the lubrication system is the primary cause of reduced bearing life.

An oil analysis will aid in determining the extent of internal engine damage; refer to Section 7 for more information.

For additional oil analysis, refer to the Cummins Engine Oil Recommendations, Bulletin No. 3810340.

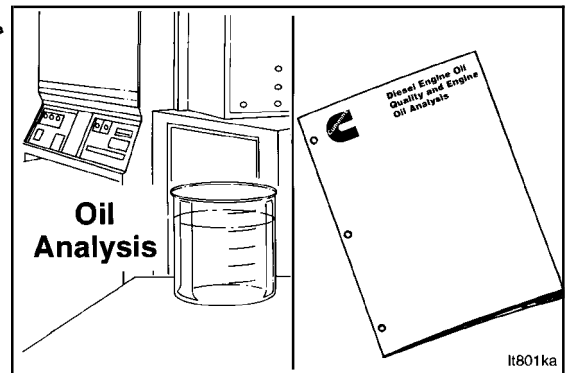

Normally, worn bearings can be detected by reduced oil pressure, but if this wear goes undetected, the excessive clearance will increase the impact between the bearing and crankshaft causing a distinct knocking sound.

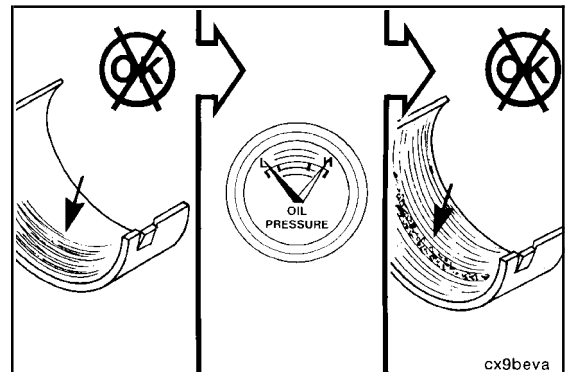

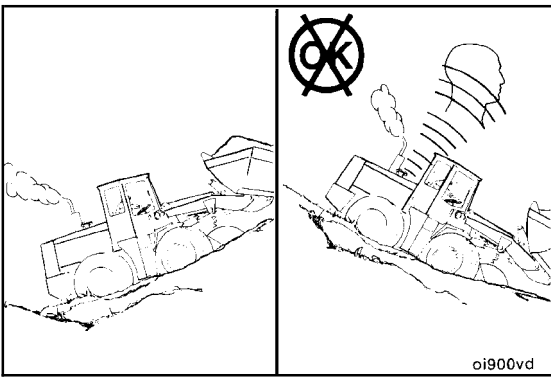

A connecting rod noise occurs when the engine is **not** loaded. Check by first applying a load, and then unloading and listening for the noise.

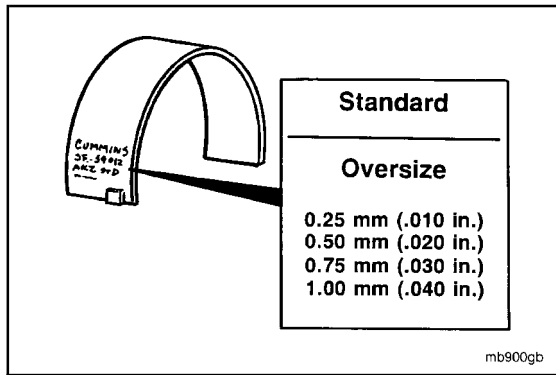

The connecting rod bearing shells are identified by steel-stamped characters on the back of the bearings. The characters indicate either standard (STD) or the amount of oversize (OS).

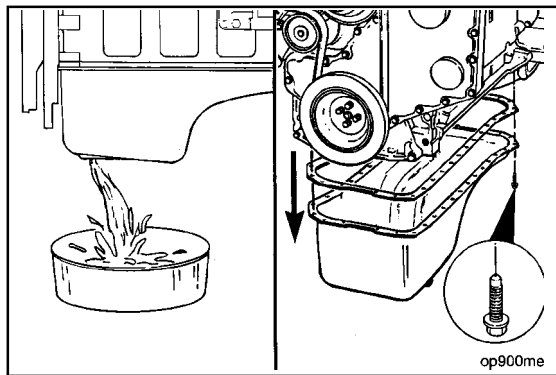

**Preparatory (001-005-000)**

**WARNING**

Some state and federal agencies have determined that used engine oil can be carcinogenic and cause reproductive toxicity. Avoid inhalation of vapors, ingestion, and prolonged contact with used engine oil.

**WARNING**

To avoid personal injury, avoid direct contact of hot oil with your skin.

Drain the lubricating oil. Refer to Procedure 007-025.

Remove the lubricating oil pan and gasket and suction tube. Refer to Procedures 007-025 and 007-035.

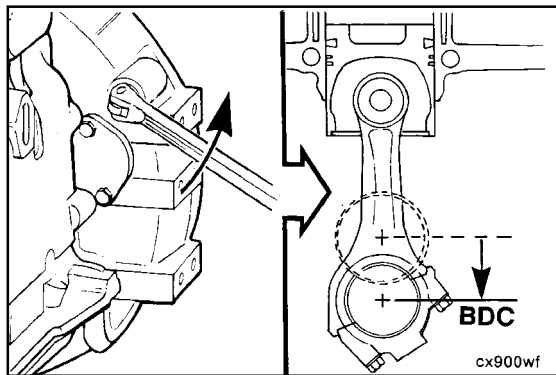

**Remove (001-005-002)**

**Engine Barring Tool, Part No. 3824591**

Using the barring tool, Part No. 3824591, rotate the crankshaft to the bottom dead center (BDC) position of the connecting rod.

12 mm

Remove the connecting rod capscrews and connecting rod caps.

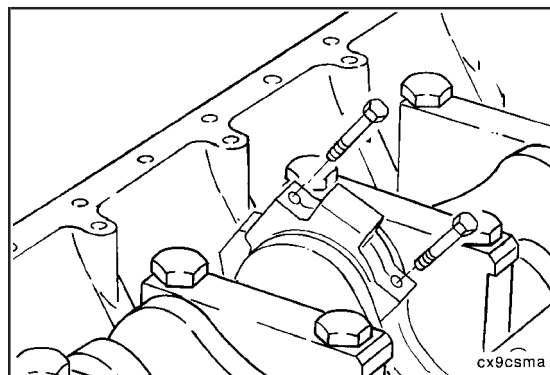

Remove the lower bearing shell from the connecting rod cap, and mark it with the letter L (lower) and the cylinder number from which it was removed.

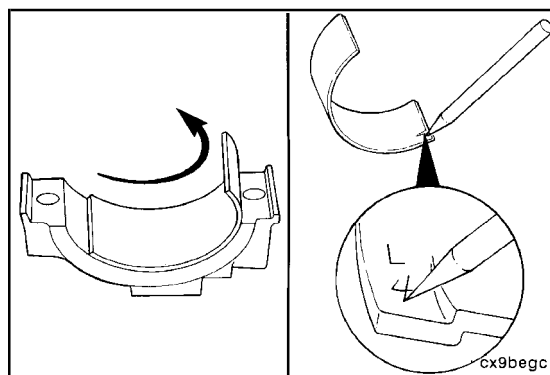

Push the connecting rod away from the crankshaft to allow the upper bearing shell to be removed.

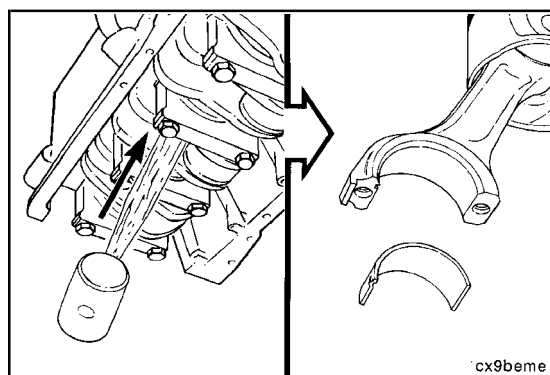

Remove the upper bearing shell, and mark it with the letter U (upper) and the cylinder number from which it was removed.

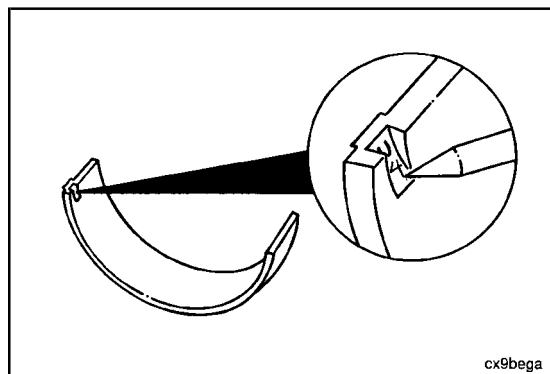

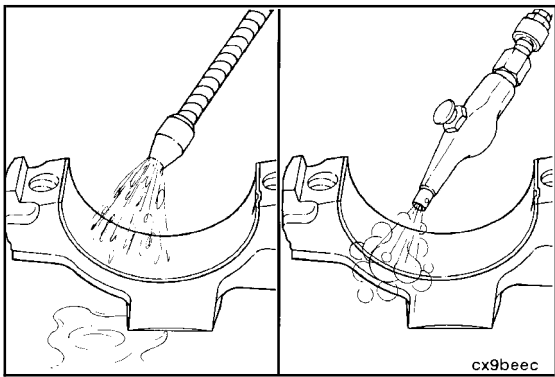

**Clean (001-005-006)**

**▲ WARNING ▲**

Wear appropriate eye and face protection when using compressed air. Flying debris and dirt can cause bodily injury.

Wash the bearing and connecting rod caps.

Dry with compressed air.

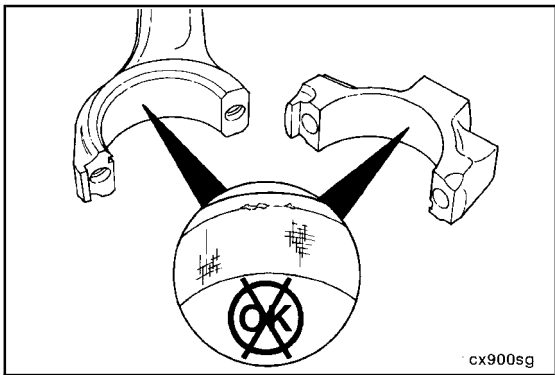

**Inspect for Reuse (001-005-007)**

Inspect the connecting rod caps, connecting rod bearing saddles, and capscrews for nicks, cracks, burrs, scratches, or frets.

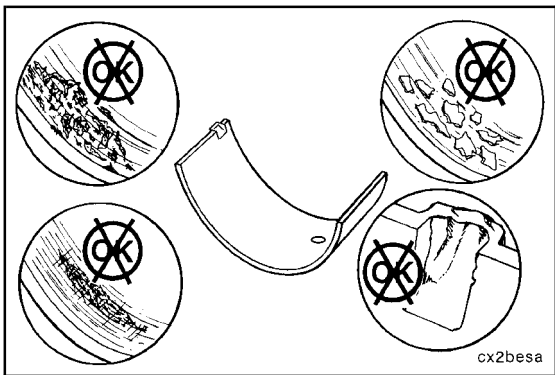

Inspect the bearings for damage. Refer to Parts Reuse Guidelines, Bulletin No. 3810303 for more information on bearing inspection.

Replace any bearings that have the following damage:

- Pits
- Flakes
- Corrosion
- Lock tang damage
- Scratches
- Heavy wear.

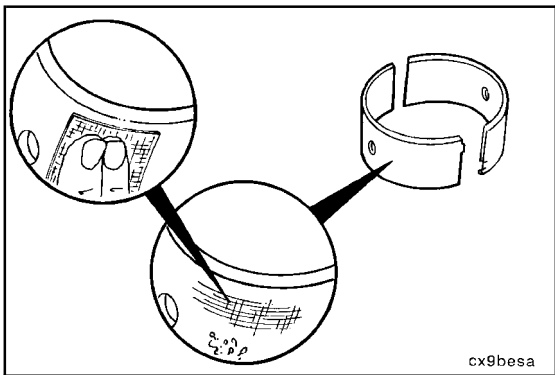

Inspect the bearing shell seating surface for nicks or burrs. If nicks or burrs can **not** be removed with Scotch-Brite™ 7448 or equivalent, the bearings **must** be replaced.

**NOTE:** If bearings are damaged, they **must** be replaced as a set.



**B3.9 and B5.9 Series Engines**  
**Section 1 - Cylinder Block - Group 01**

Use an outside diameter ball-tipped micrometer to measure the connecting rod bearing thickness.

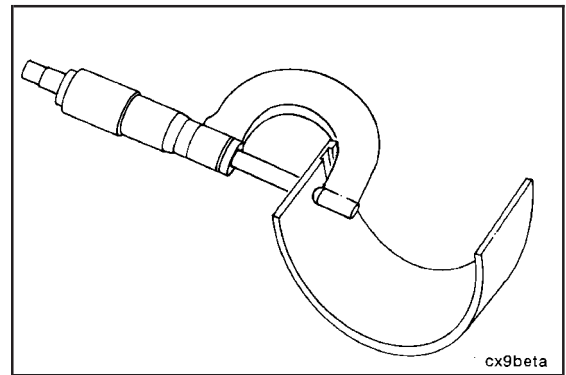

**Connecting Rod Bearing Dimensions**

	mm		in
Standard	1.955	MIN	0.0770
	1.968	MAX	0.0775
0.25 mm Oversize	2.080	MIN	0.0819
	2.093	MAX	0.0824
0.50 mm Oversize	2.205	MIN	0.0868
	2.218	MAX	0.0873
0.75 mm Oversize	2.330	MIN	0.0917
	2.343	MAX	0.0922
1.00 mm Oversize	2.455	MIN	0.0967
	2.468	MAX	0.0972

**NOTE:** Connecting rod bearings are identified with the part number and size stamped on the back.

Determine the size of the removed rod bearing, and obtain a set of the same size.

**NOTE:** Oversize service rod bearings are available for use with crankshafts that have been machined undersize.

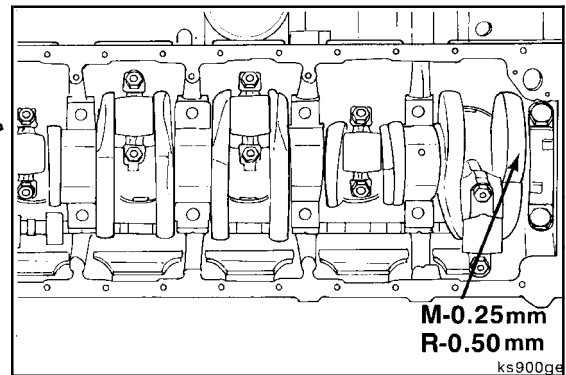

Crankshafts that are machined undersize on the connecting rod or main bearing journals are marked on the front counterweight. If the crankshaft is marked, check the bearing shell part number to make sure the correct bearing size is used.

**NOTE:** Bearing shells are identified by steel-stamped characters on the back of the bearings to indicate either standard (STD) or oversize (OS).

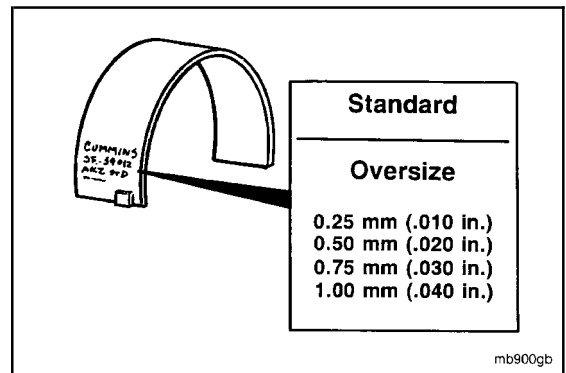

**Install (001-005-026)**

**NOTE:** Used bearings **must** be installed in the same location from which they were removed.

Use clean lubricating engine oil to coat the inside diameter of the bearing shell.

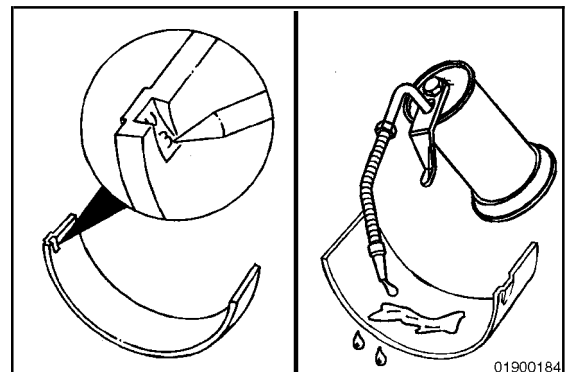

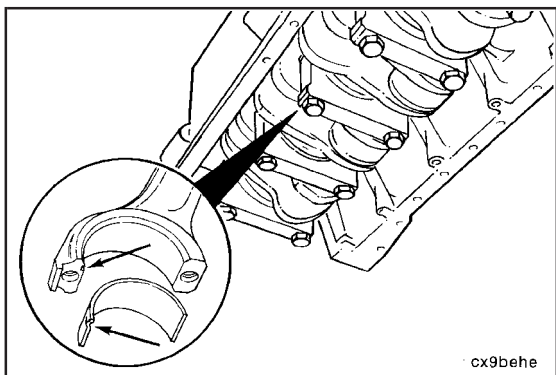

Install the upper bearing shell in the connecting rod with the tang of the bearing in the slot of the connecting rod.

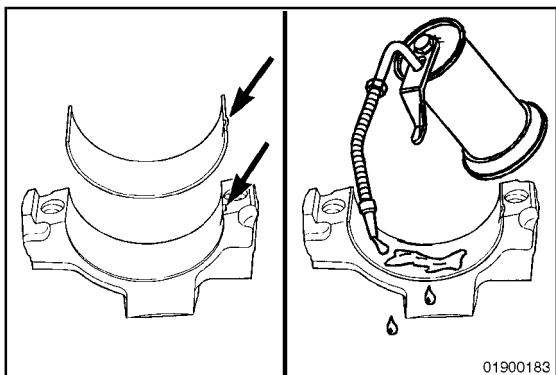

Install the bearing shell in the connecting rod cap with the tang of the bearing in the slot of the connecting rod cap.

Use clean lubricating engine oil to coat the inside diameter of the bearing shell.

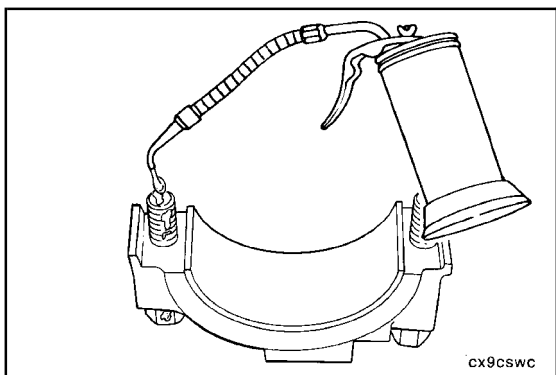

Use clean lubricating engine oil to lubricate the threads and underside of the connecting rod capscrew head.

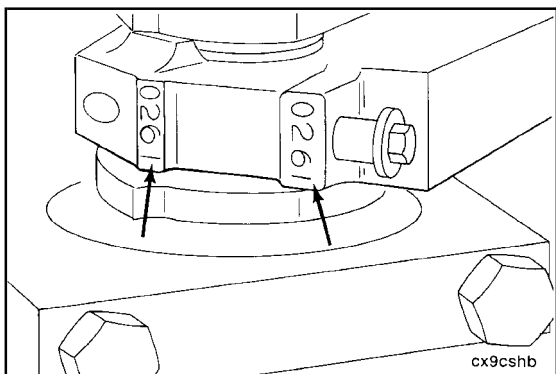

The four-digit number stamped on the connecting rod and connecting rod cap at the parting line **must** match and be installed on the lubricating oil cooler side of the engine.

Install the connecting rod cap and capscrews to the connecting rod.

**B3.9 and B5.9 Series Engines**  
**Section 1 - Cylinder Block - Group 01**

**12 mm, Torque Wrench**

Alternately tighten the two capscrews.

- Torque Value:** Step 1 30 N•m [22 ft-lb]  
 Step 2 60 N•m [44 ft-lb]  
 Step 3 Turn clockwise 60 degrees

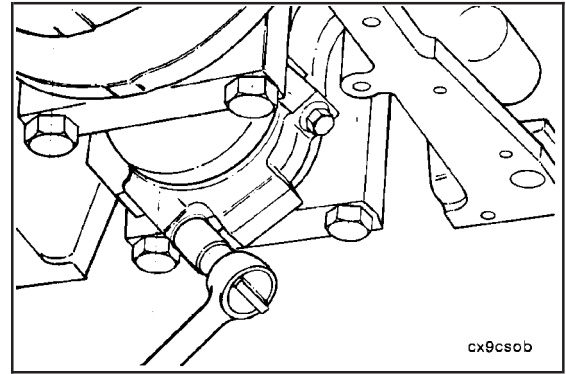

Measure the side clearance between the connecting rod and crankshaft.

Do **not** measure the clearance between the connecting rod cap and crankshaft.

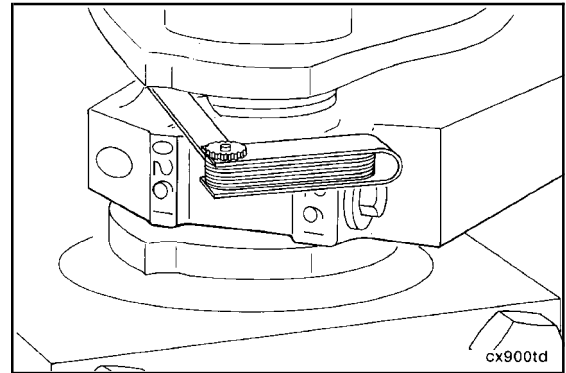

**Connecting Rod Side Clearance Limits**

mm		in
0.10	MIN	0.004
0.33	MAX	0.013

**NOTE:** The crankshaft **must** rotate freely.

Check for freedom of rotation as the connecting rod caps are installed. If the crankshaft does **not** rotate freely, check the installation of the connecting rod bearings and bearing size.

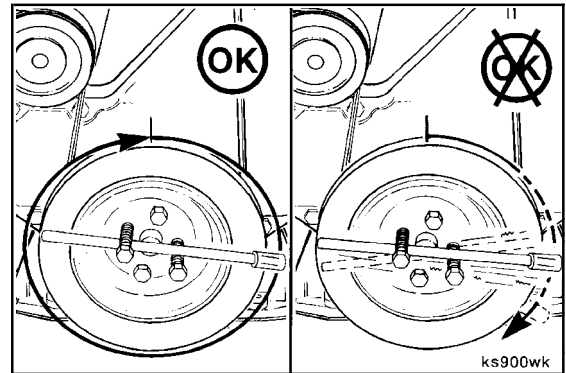

Install the suction tube, lubricating oil pan, and gasket. Refer to Procedure 007-025 and 007-035.

**Torque Value:**

- Lubricating Oil Pan 24 N•m [18 ft-lb]

**Torque Value:**

- Lubricating Suction Tube 24 N•m [18 ft-lb]

Fill the lubricating oil pan. Refer to Section 7 - Lubricating Oil System, General Information, for the correct lubricating oil specification.

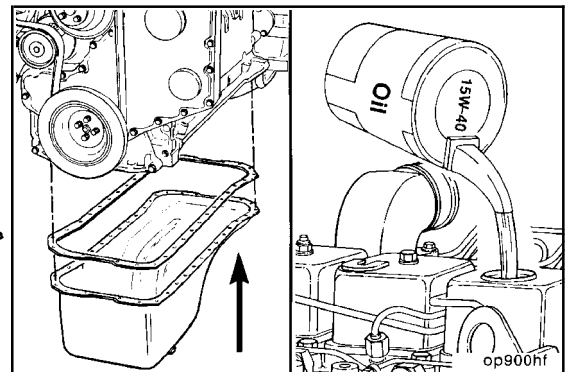

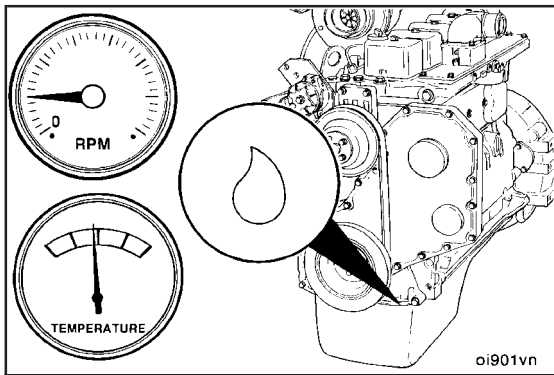

Operate the engine to normal operating temperature, and check for leaks.

## Bearings, Main (001-006)

### General Information

The crankshaft is a balanced, forged steel unit. Four-cylinder engines have five main bearings. Six-cylinder engines have seven main bearings. The lower bearing shells are all the same. All of the upper bearing shells are also the same with the exception of the journal adjacent to the rear one. The next to last journal is fitted with a flanged upper bearing shell. The flanges control the end thrust of the crankshaft.

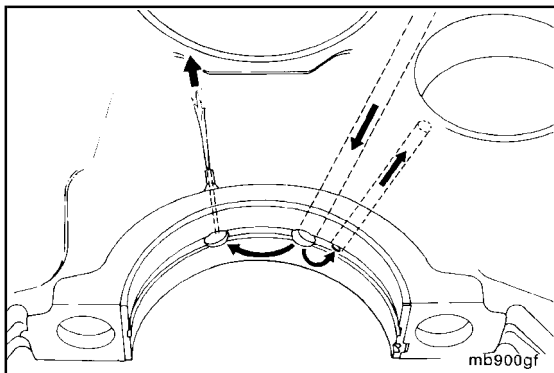
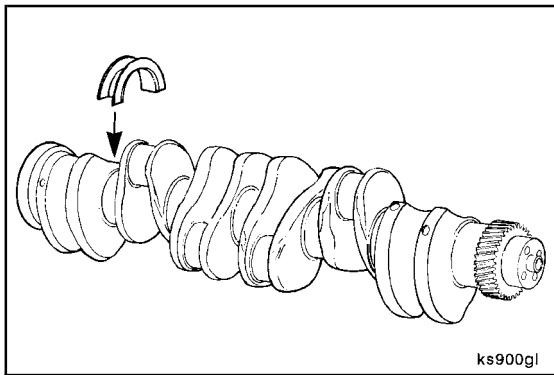

The upper bearings have three holes in them. The middle hole receives lubricating oil from the main oil rifle. One of the adjacent holes is aligned with a drilling in the camshaft journal and serves as an orifice for lubrication flow to the journal. The other adjacent hole supplies lubricating oil for piston cooling. The hole does **not** align perfectly with the cooling nozzle. The hole is offset to keep it away from the highly loaded bearing area.

**NOTE:** Oversize service main bearings are available for reground crankshafts.

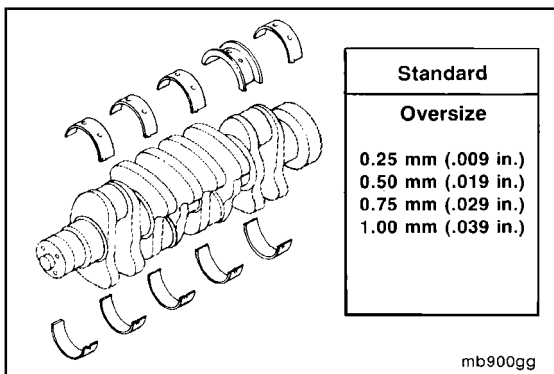

Improper maintenance of the lubricating system is the primary cause of reduced main bearing life.

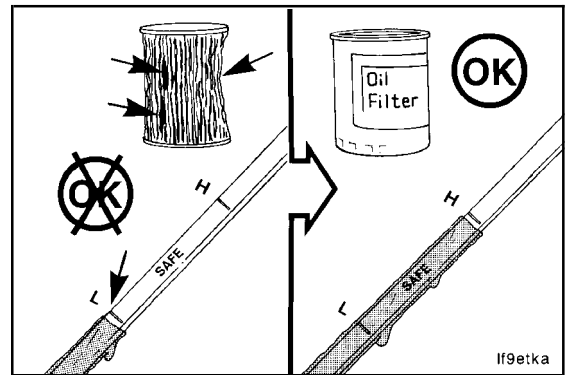

**⚠ CAUTION ⚠**

Increased end-loading of the engine and its driven units at the front or rear of the engine can cause damage to the thrust bearings.

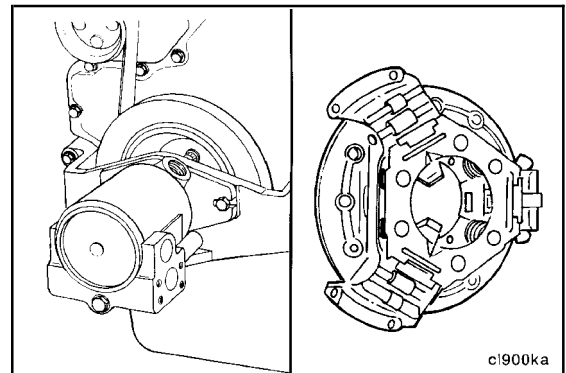

**Preparatory (001-006-000)**

**⚠ WARNING ⚠**

To avoid personal injury, avoid direct contact of hot oil with your skin.

Drain the lubricating oil. Refer to Procedure 007-025.

Remove the lubricating oil pan and gasket. Refer to Procedure 007-025.

**NOTE:** Before removing the main bearing caps, make certain that the caps are clearly marked for their location on the lubricating oil cooler side of the main bearing cap.

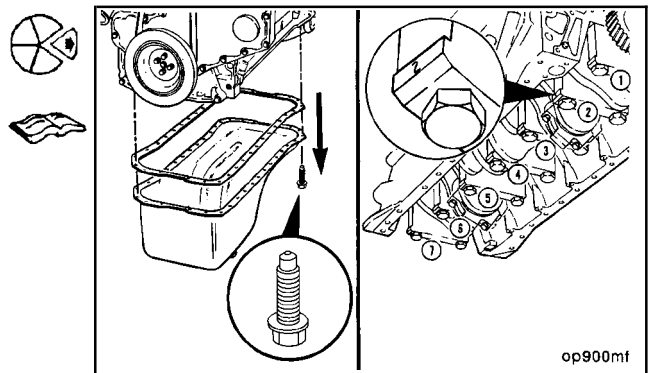

**Remove (001-006-002)**

**NOTE:** Before removing the main bearing caps, make sure that the caps are clearly marked for location on the lubricating oil cooler side of the main bearing cap.

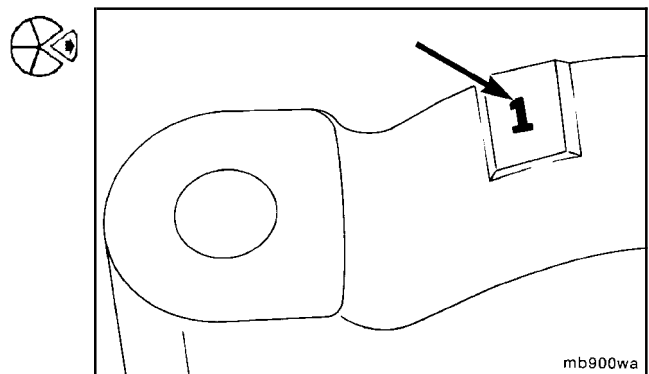

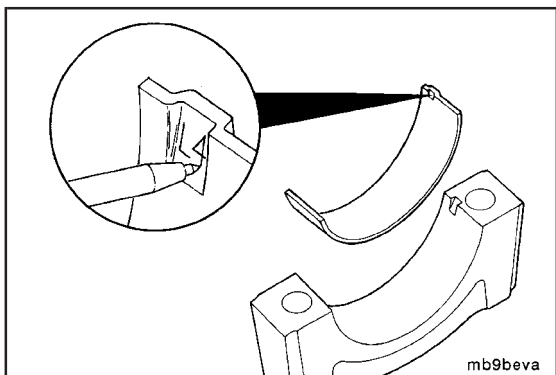

Mark the bearing shell with the letter L (lower) and the journal number it was removed from.

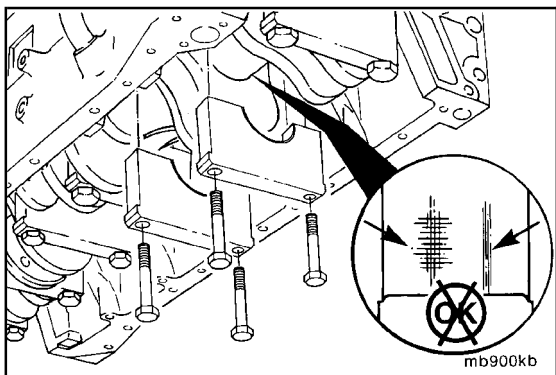

Perform an inspection of the main bearings and crankshaft journals. Remove the No. 2 and 3 caps, and check the crankshaft journals for signs of overheating, deep scratches, or other damage. If there is no damage, there is no need to pull the other main bearing caps at this time.

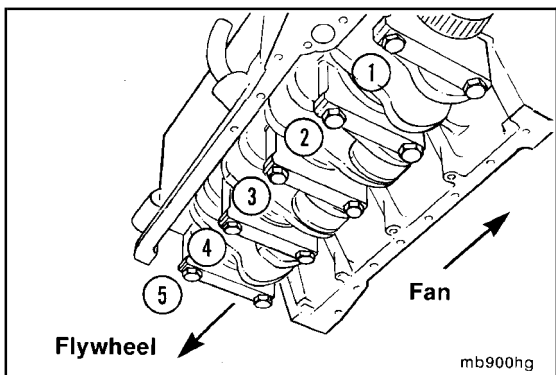

Remove all main bearing caps except the No. 1 and 7 main bearing caps for six-cylinder engine. The four-cylinder engine is depicted in the illustration.

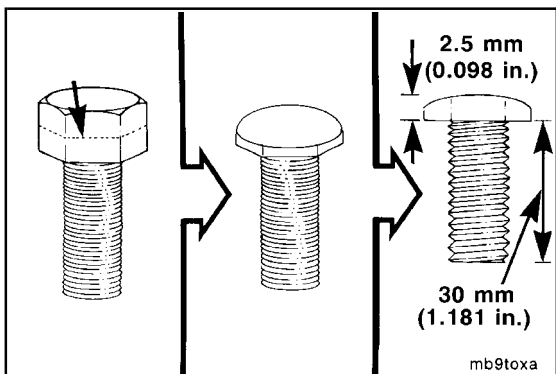

Use a pin to roll out the upper bearings from between the crankshaft and cylinder block.

To make a pin, grind a 6-mm [0.24-in] capscrew to the dimensions shown.

Install the pin into the lubricating oil hole in the crankshaft. Rotate the crankshaft so the pin pushes against the end of the main bearing opposite the tang. Remove the main bearing.

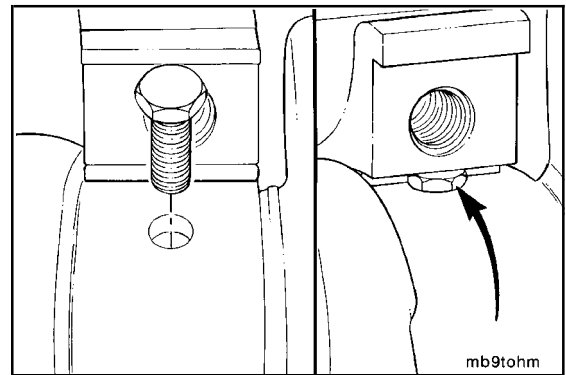

Follow this procedure to remove the other main bearings.

**Clean (001-006-006)**

**CAUTION**

Do not use a scraper or a wire brush. The bearings can be damaged.

**WARNING**

When using solvents, acids, or alkaline materials for cleaning, follow the manufacturer's recommendations for use. Wear goggles and protective clothing to avoid personal injury.

**WARNING**

Wear appropriate eye and face protection when using compressed air. Flying debris and dirt can cause bodily injury.

**NOTE:** Make sure the bearings are marked for location. The bearings **must** be installed in their original location if used again.

Use solvent and a soft bristle brush to clean bearings.

Dry with compressed air.

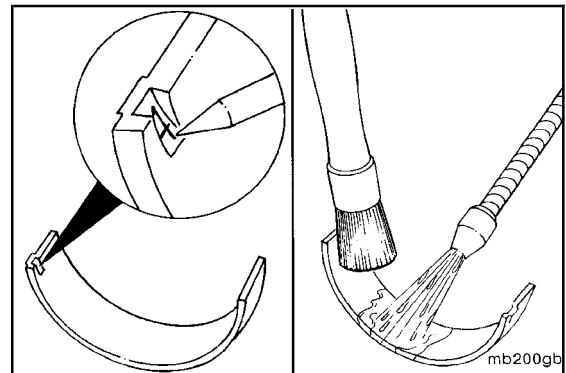

**Inspect for Reuse (001-006-007)**

Inspect all main bearing caps and main bearing crankshaft journals for dents, cracks, deep scoring, overheating, and other damage.

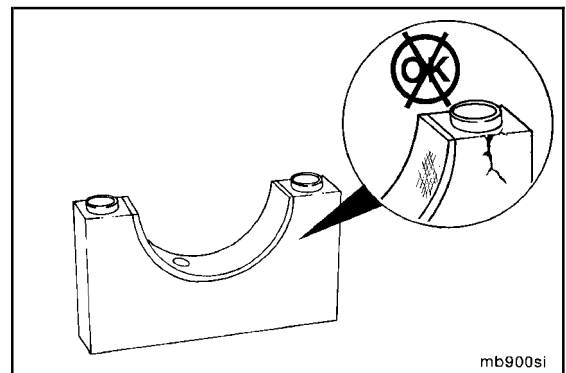

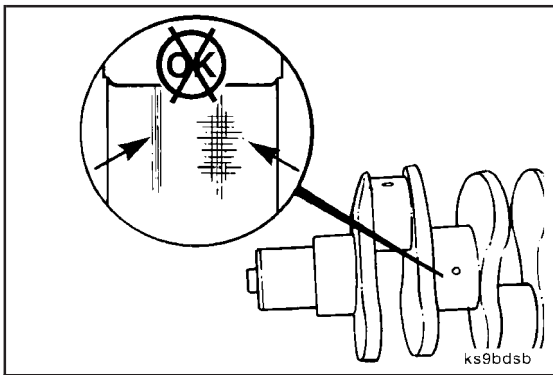

Inspect the crankshaft journals for deep scratches, indications of overheating, and other damage.

**NOTE:** If the crankshaft journals or main caps are damaged, the engine will need to be removed to complete the overhaul.

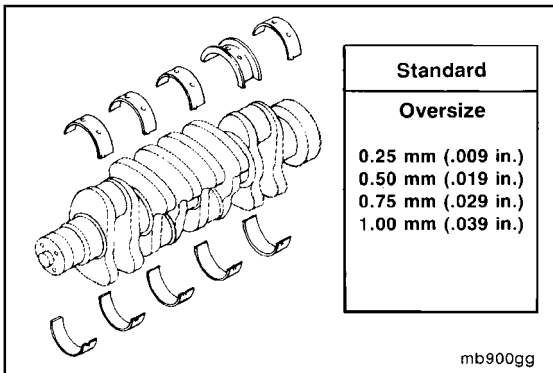

Determine the size of the main bearing removed, and obtain the same size for installation.



Refer to Procedure 001-016 for measurement specifications.

Refer to Base Engine Component Specifications for the dimensions of the standard and undersize main bearing journals.

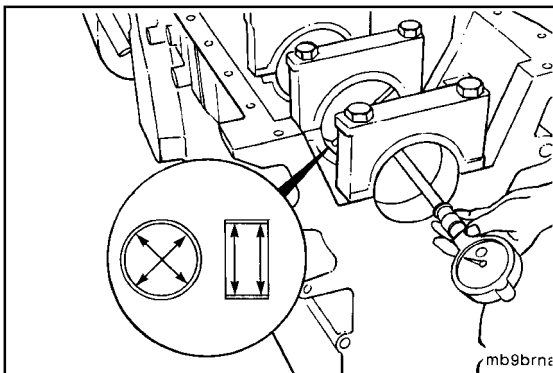

Measure the installed main bearing bore diameter.

Main Bearing Bore Diameter (Maximum)		
mm		in
83.106	MAX	3.272

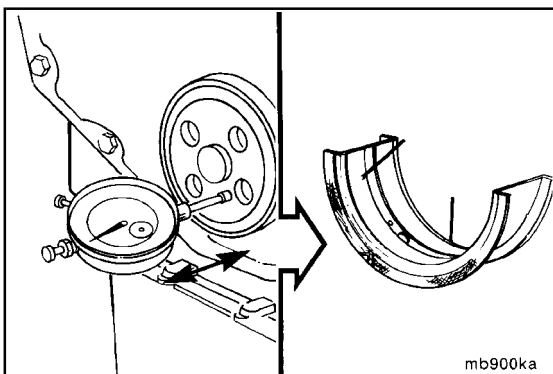

**Measure (001-006-010)**

A damaged, worn, or missing thrust bearing flange on the upper main bearing shell can be detected by measuring the end play of the crankshaft.

Dimension (A) End Play Limits		
mm		in
0.127	MIN	0.005
0.431	MAX	0.017



Install (001-006-026)

**CAUTION**

Do not lubricate the side that is against the cylinder block. Engine failure can occur.

Apply a coat of clean lubricating engine oil to the new upper main bearings.

**NOTE:** Used bearings **must** be installed in their original location.

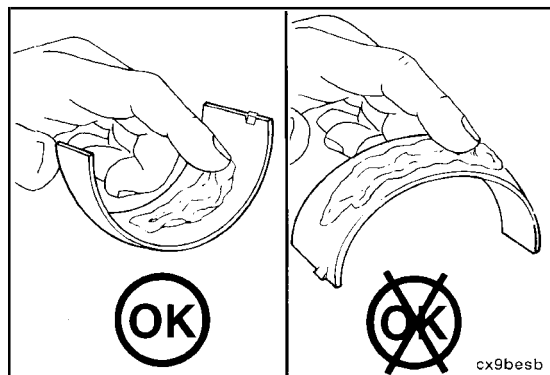

Position the new main bearing on the crankshaft, and install as far as possible by hand.

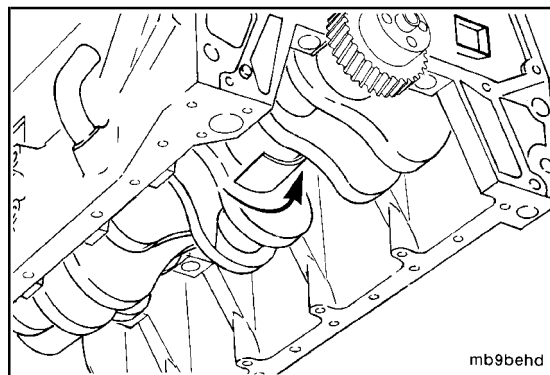

Using the pin and rotation of the crankshaft, finish pushing the main bearing in slowly, being sure it is aligned with the cylinder block. Make sure the tang on the main bearing sets into the notch.



Make sure the pin does **not** slide under the bearing.

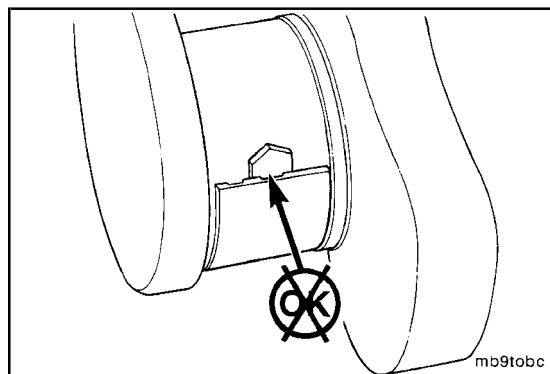

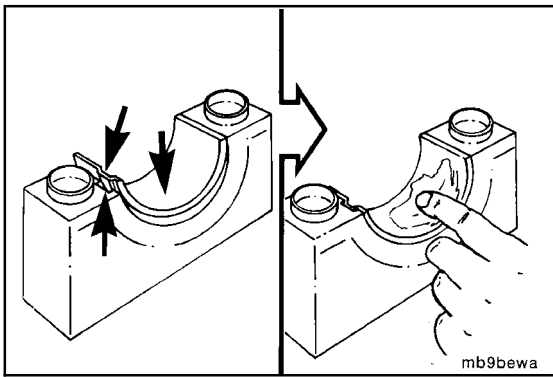

Install the lower main bearings into the main bearing caps. Apply a coat of clean lubricating engine oil to the inside of the main bearings.



**NOTE:** Do **not** lubricate the back of the bearing shell.

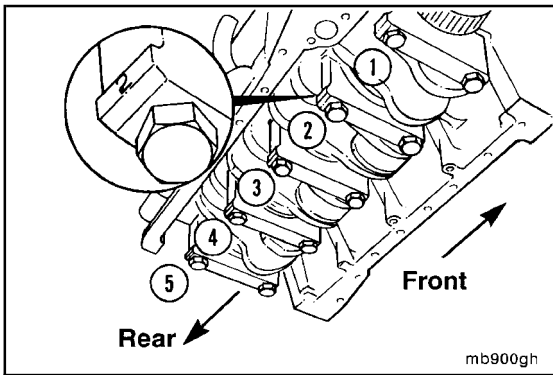

**CAUTION**

Make sure the caps are correctly installed with the number toward the oil cooler side of the engine. Failure to do so can result in engine damage.



23 mm



Install a main bearing cap after each upper main bearing is installed to keep the main bearing in place while the other uppers are installed.

**Torque Value:** 50 N•m [37 ft-lb]

Do **not** tighten to the final torque value at this time.

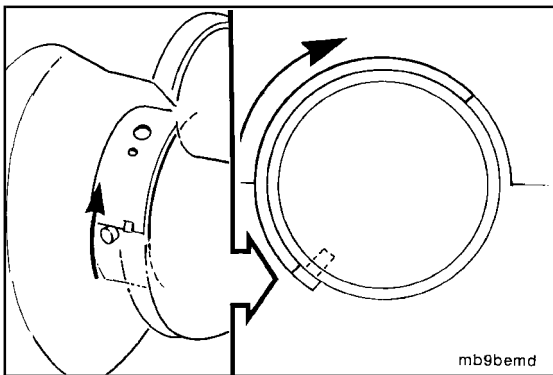

Use the same procedure to remove and install rear main bearing cap, No. 5 or No. 7.

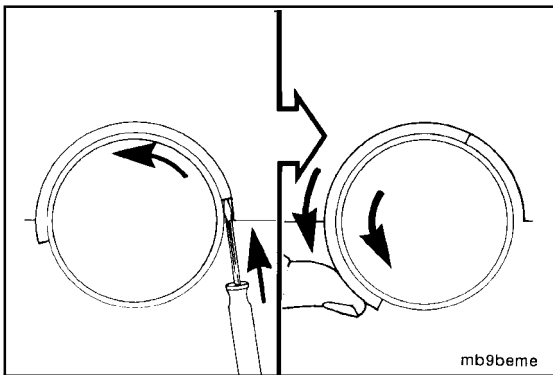

**CAUTION**

Use care so the screwdriver does not damage the crankshaft or cylinder block.



**Flat-Blade Screwdriver**

**NOTE:** The front main, No. 1, does **not** have a hole in the journal, so the pin can **not** be used to replace the bearing.

Use a flat-blade screwdriver. Gently bump the end of the bearing to loosen it from the cylinder block. Then, use finger pressure against the main bearing shell, and rotate the crankshaft to roll the main bearing out.

**B3.9 and B5.9 Series Engines**  
**Section 1 - Cylinder Block - Group 01**

Lubricate and install the main bearing.

Use the screwdriver to push the main bearing into position as you rotate the crankshaft.

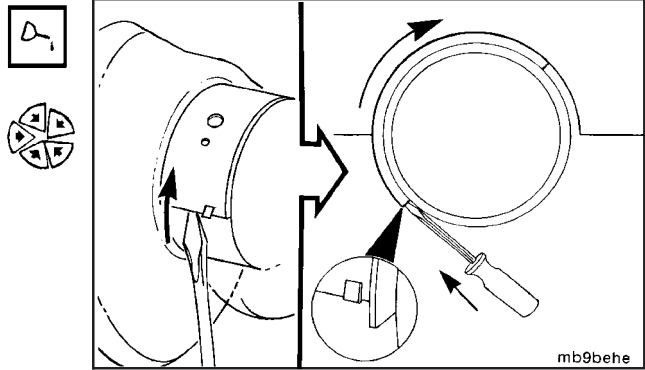

**23 mm**

**NOTE:** The crankshaft **must** rotate freely.

Tighten the capscrews evenly and in sequence.

**Torque Value:** Step 1 60 N•m [44 ft-lb]  
 2 90 N•m [66 ft-lb]  
 3 Turn clockwise 90 degrees.

Check the main bearing installation and the size of the main bearings if the crankshaft does **not** rotate freely.

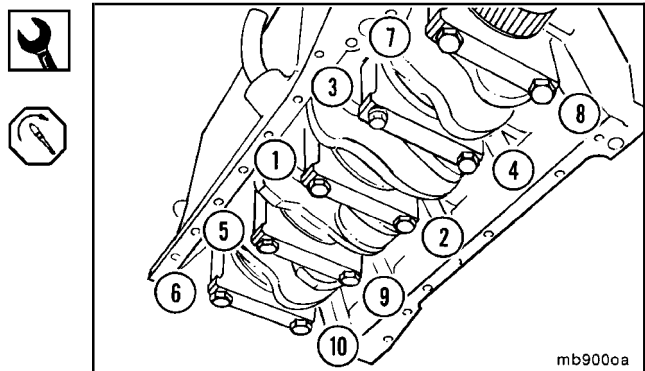

**NOTE:** The dimensions of the thrust bearing and crankshaft journal determine end play.

Measure the crankshaft end play.

Dim. (A) End Play Limits		
mm		in
0.102	MIN	0.004
0.432	MAX	0.017

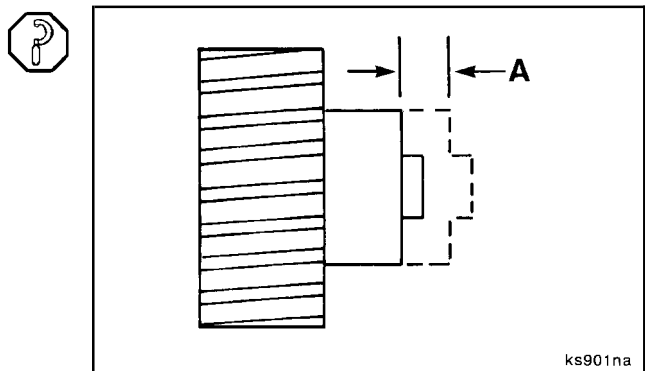

**10 mm**

Install the lubricating oil pan and gasket. Refer to Procedure 007-025.

**Torque Value:** 24 N•m [18 ft-lb]

Fill the lubricating oil pan. Refer to the Operation and Maintenance Manual, B Series Engines, Bulletin No. 3810205 for the correct lubricating specification.

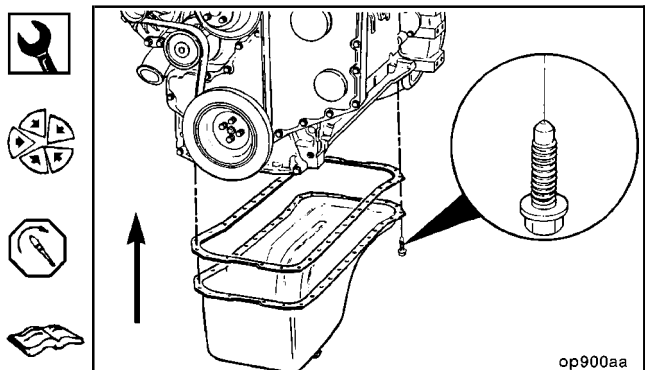

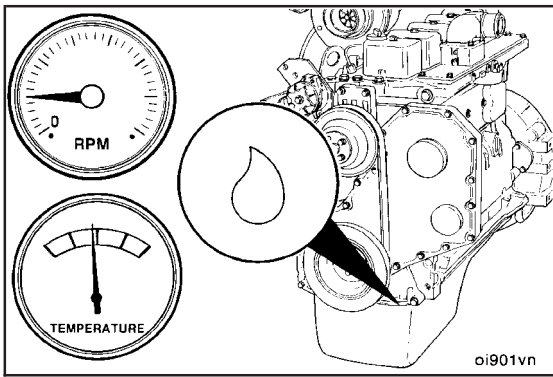

Operate the engine at idle for 5 to 10 minutes. Check for loose parts and leaks.

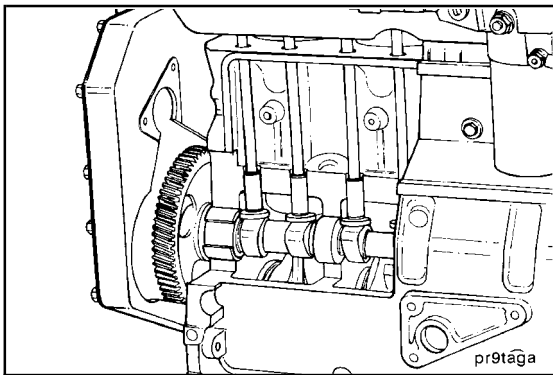

### Camshaft (001-008)

#### General Information

The camshaft is gear-driven from the crankshaft. A replaceable bushing is used for the front journal to carry the side-loading from the accessory drive. The remainder of the journals operate in cast-iron bores in the cylinder block; however, these bores can be repaired in a machine shop by installing service bushings.

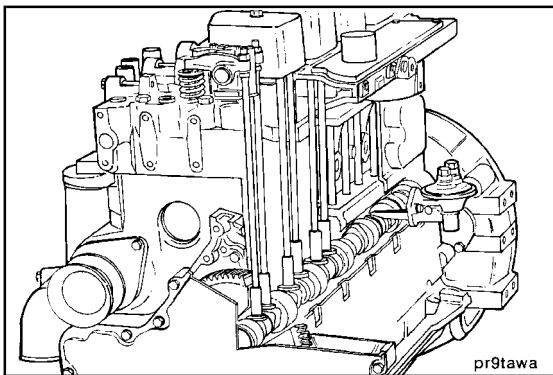

The camshaft has lobes to operate the intake and exhaust valves and a special lobe to drive the fuel transfer pump. The valve lobes contact "mushroom"-shaped valve tappets that operate the push tubes. The operating arm of the fuel transfer pump rides directly on the special lobe on the camshaft. The profile of the camshaft lobes is the same for all B Series engines except 1994 automotive engines, which use a new early intake valve opening intake lobe.

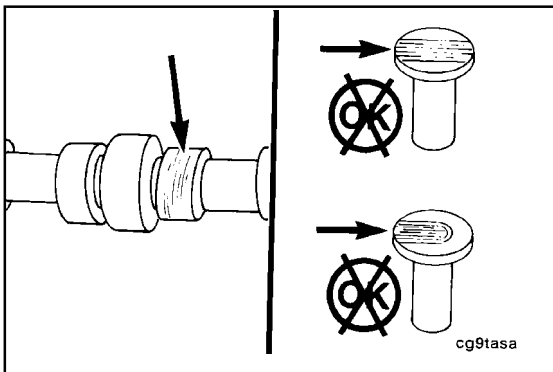

#### Diagonosing Malfunctions

Loose rocker levers and the need to reset the valve clearance fequently can indicate camshaft lobe or tappet wear. If an inspection of the levers, valve stems, and push tubes does **not** show wear, then tappet or camshaft lobe wear should be suspected.

**⚠ CAUTION ⚠**

Anytime a new camshaft is installed, new tappets and push tubes must be installed to prevent damage to the camshaft and tappet surfaces.

The camshaft lobes can be inspected after removing the oil pan. Also, the face of the tappets can be inspected after removing the push tubes and lifting the tappets.

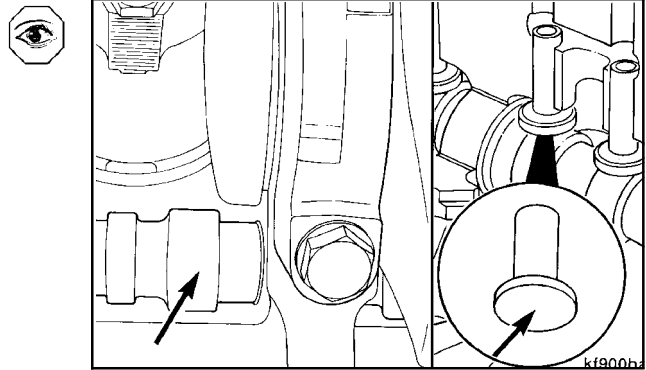

A severely damaged camshaft journal(s) can generate small metal particles that can be found in the oil pan and oil filter. These metal particles will also be indicated as iron in the oil analysis. As the clearance in the journal(s) increases, a small decrease in oil pressure can be detected.

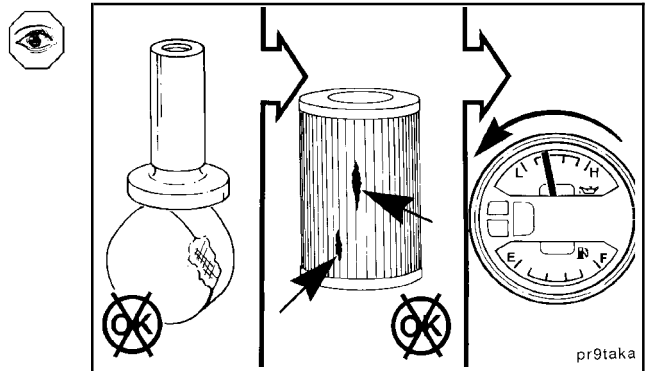

**Camshaft Gear Installation/Removal Tool, Part No. 3383589**

The camshaft end clearance is determined by the clearance between the camshaft and the thrust plate. The camshaft gear **must** be removed to adjust the camshaft end clearance.

**NOTE:** The camshaft does **not** have to be removed to remove the camshaft gear. Use the the camshaft installation and removal tool, Part No. 3823589.

Camshafts that are damaged, worn on the fuel transfer pump lobe or the valve lobes **must** be replaced. Cummins Engine Co., Inc. does **not** recommend grinding camshaft lobes.

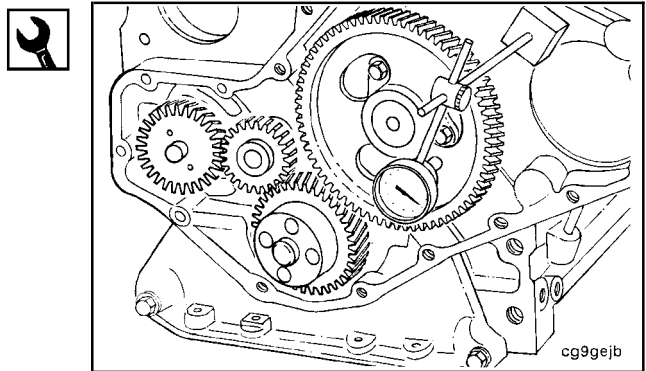

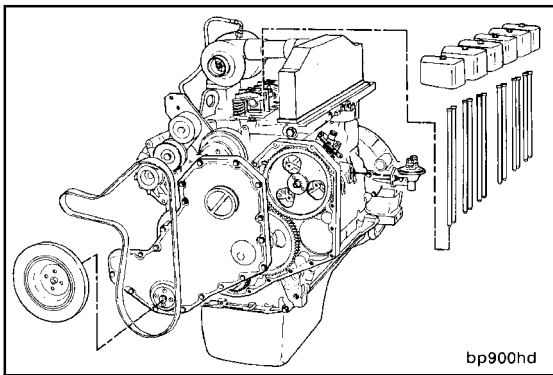

**Preparatory (001-008-000)**

**▲ CAUTION ▲**



Anytime a new camshaft is installed, new tappets and push tubes must be installed to prevent damage to the camshaft and tappet surfaces.

- Remove the rocker lever cover. Refer to Procedure 003-011.
- Remove the rocker levers. Refer to Procedure 003-008.
- Remove the push tubes. Refer to Procedure 004-014.
- Remove the drive belt. Refer to Procedure 008-002.
- Remove the vibration damper. Refer to Procedure 001-052 or 001-051.
- Remove the gear cover. Refer to Procedure 001-031.
- Remove the fuel transfer pump. Refer to Procedure 005-045.
- Raise the tappets. Refer to Procedure 004-015.

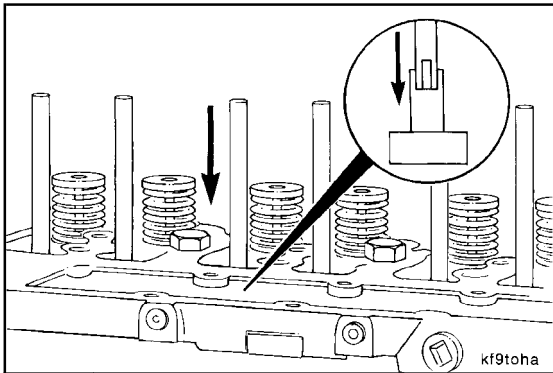

**Remove (001-008-002)**

**Tappet Changing Tool, Part No. 3822513**



Insert the wooden dowels through the push tube holes and into the top of each tappet securely. When properly installed, the dowels can be used to pull the tappets up and should **not** be able to be pulled out without considerable effort.

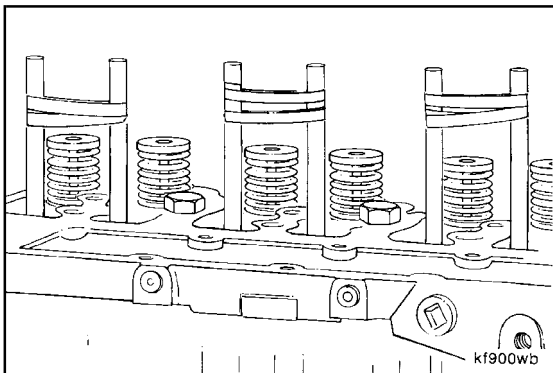

Pull the tappets up, and wrap a rubber band around the top of the dowel rods. This will prevent the tappets from dropping down.

Rotate the crankshaft to align the crankshaft with the camshaft timing marks.

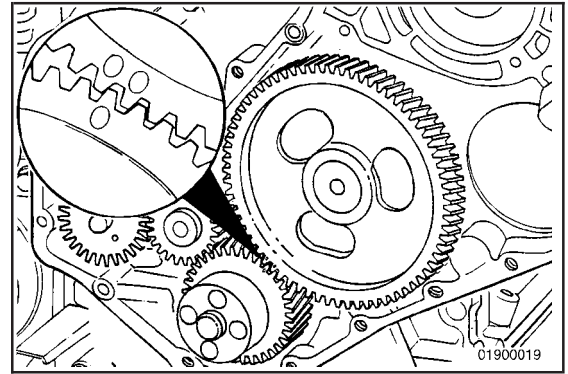

13 mm

Remove the capscrews from the thrust plate.  
 Remove the camshaft thrust plate.

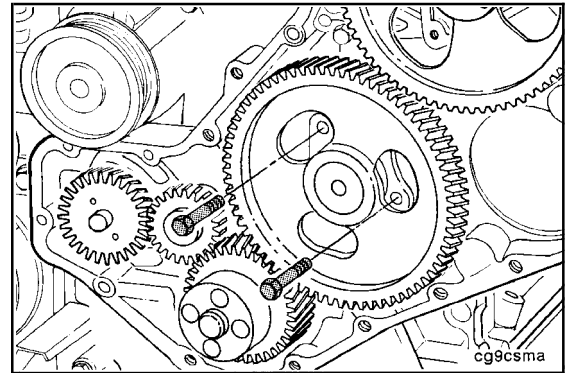

Remove the camshaft from the cylinder block.

**NOTE:** Rotate the camshaft as it is being removed. Use extreme care to make sure that the cam bushings are **not** damaged during the process.

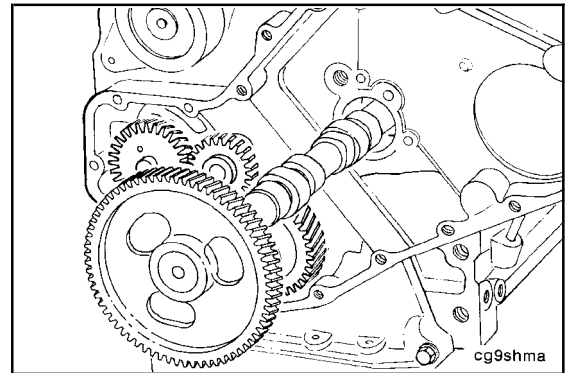

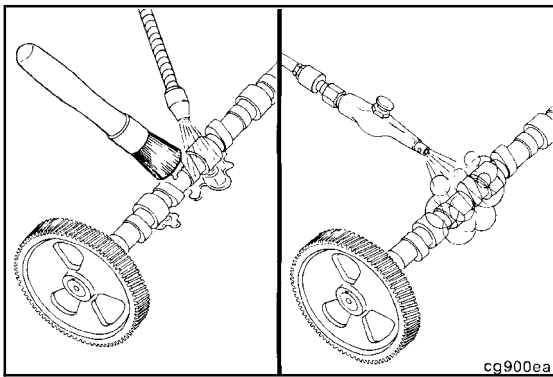

**Clean (001-008-006)**

**▲ WARNING ▲**

When using a steam cleaner, wear safety glasses or a face shield, as well as protective clothing. Hot steam can cause serious personal injury.

**▲ WARNING ▲**

When using solvents, acids, or alkaline materials for cleaning, follow the manufacturer's recommendations for use. Wear goggles and protective clothing to avoid personal injury.

**▲ WARNING ▲**

Wear appropriate eye and face protection when using compressed air. Flying debris and dirt can cause bodily injury.

Use solvent or steam to clean the camshaft.

Dry with compressed air.

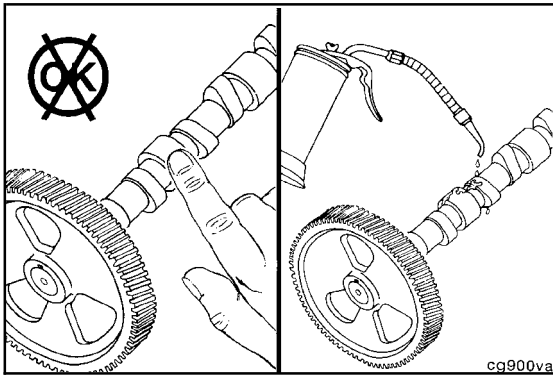

**▲ CAUTION ▲**

Do not touch the machined surfaces with bare hands; this can cause rust to form on the camshaft.

Lubricate the camshaft with clean lubricating engine oil before handling.

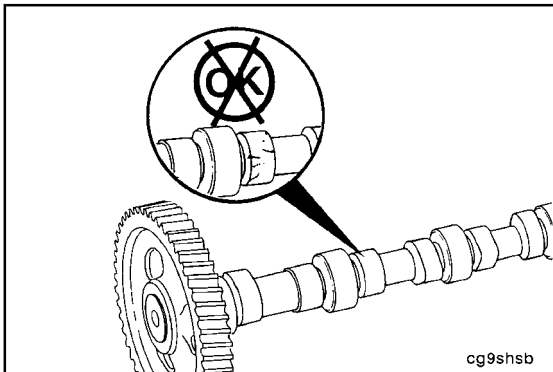

**Inspect for Reuse (001-008-007)**

**NOTE:** Anytime a new camshaft is installed; new tappets and push tubes **must** be installed also.

Inspect the fuel transfer pump lobe, valve lobes, and bearing journals for cracking, pitting, or scoring.



Inspect the camshaft gear teeth for pitting; look for cracks at the root of the teeth.

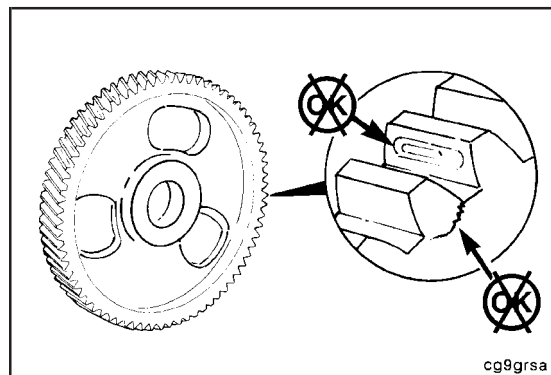

Measure the valve lobes.

**4B Engine Peak of Lobe Diameter by Camshaft Part No.**

<b>Part No.</b>	<b>Minimum Intake</b>	<b>Minimum Exhaust</b>
3929039	45.400 mm [1.787 in]	45.141 mm [1.777 in]
3925582	45.400 mm [1.787 in]	45.141 mm [1.777 in]
3914638	45.400 mm [1.787 in]	45.141 mm [1.777 in]
3929885	45.795 mm [1.803 in]	44.649 mm [1.758 in]
3929038	45.795 mm [1.803 in]	44.166 mm [1.739 in]
3924574	45.795 mm [1.803 in]	44.166 mm [1.739 in]
3931281	45.400 mm [1.787 in]	44.649 mm [1.758 in]
3930346	45.400 mm [1.787 in]	44.649 mm [1.758 in]

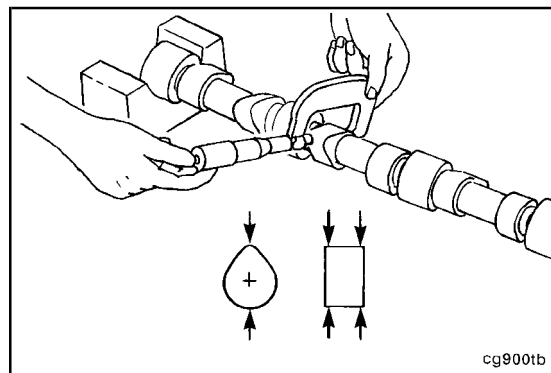

Measure the valve lobes.

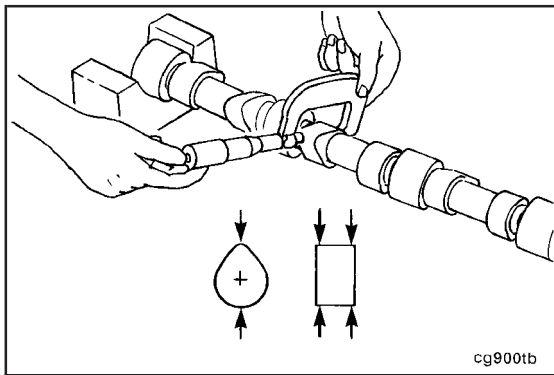

**6B Engine Peak of Lobe Diameter  
by Camshaft Part No.**

Part No.	Minimum Intake	Minimum Exhaust
3283179	45.795 mm [1.803 in]	44.649 mm [1.758 in]
3929734	45.795 mm [1.803 in]	45.141 mm [1.777 in]
3929040	45.795 mm [1.803 in]	45.141 mm [1.777 in]
3926671	45.795 mm [1.803 in]	45.141 mm [1.777 in]
3924109	45.258 mm [1.782 in]	45.141 mm [1.777 in]
3929041	45.400 mm [1.787 in]	45.141 mm [1.777 in]
3921953	45.400 mm [1.787 in]	45.141 mm [1.777 in]
3930469	45.400 mm [1.787 in]	45.141 mm [1.777 in]
3919608	45.400 mm [1.787 in]	45.141 mm [1.777 in]
3929042	45.400 mm [1.787 in]	45.141 mm [1.777 in]
3914639	45.400 mm [1.787 in]	45.141 mm [1.777 in]
3929886	45.795 mm [1.803 in]	44.649 mm [1.758 in]
3930378	45.400 mm [1.787 in]	44.649 mm [1.758 in]
3283179	45.795 mm [1.803 in]	44.649 mm [1.758 in]

Measure the fuel transfer pump lobe.

Fuel Transfer Pump Lobe Diameter		
mm		in
35.50	MIN	1.398
36.26	MAX	1.428

Measure the bearing journals.

Journal Diameter		
mm		in
53.962	MIN	2.1245
54.013	MAX	2.1265

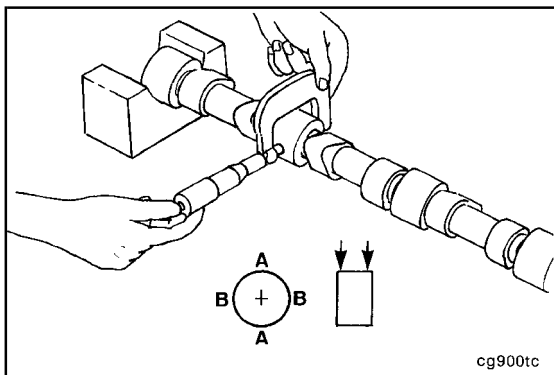

**Pitting Reuse Criteria**

A single pit should **not** be greater than the area of a 2-mm [0.079-in] diameter circle.

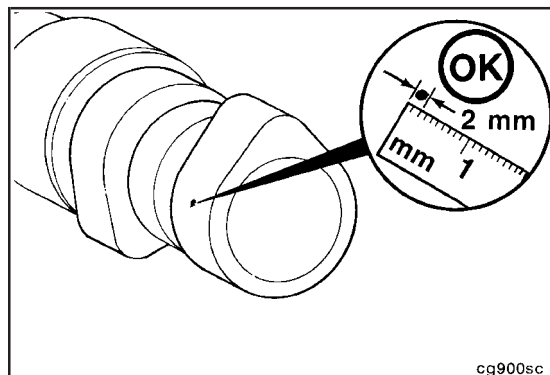

cg900sc

Interconnection of pits is **not** allowable and is treated as one pit.

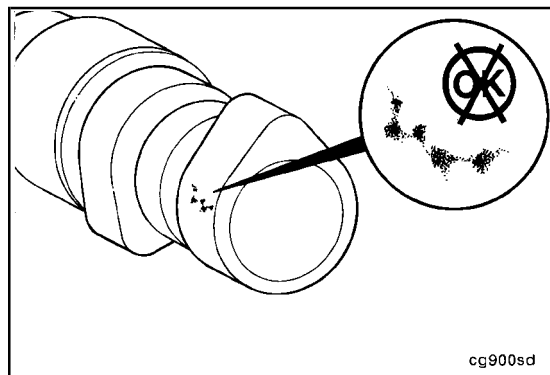

cg900sd

The total pits, when added together, should **not** exceed a circle of 6 mm [0.236 in].

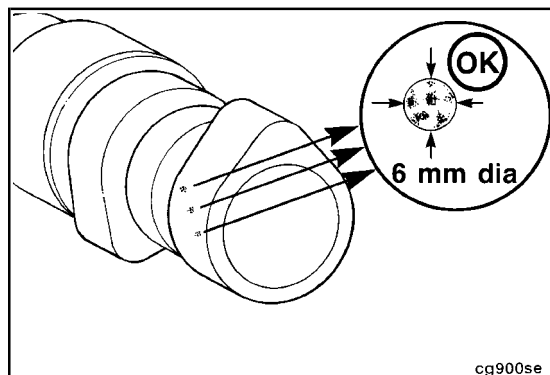

cg900se

**Only** one pit is allowed within  $\pm 20$  degrees of the nose of the cam lobe.

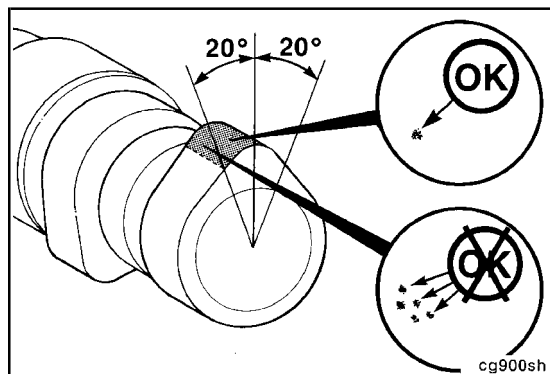

cg900sh

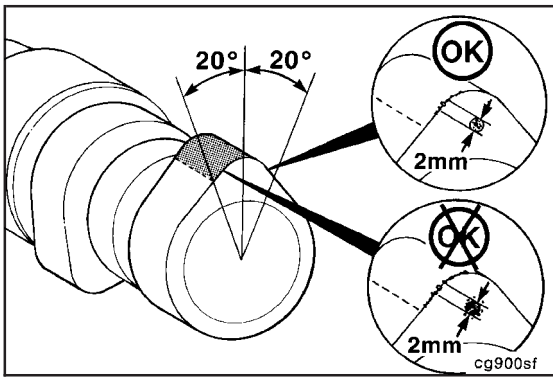

**Edge Deterioration (Breakdown) Criteria**

The area of edge deterioration should not be greater than the equivalent area of a 2-mm [0.079-in] circle within  $\pm 20$  degrees of the nose of the cam lobe.

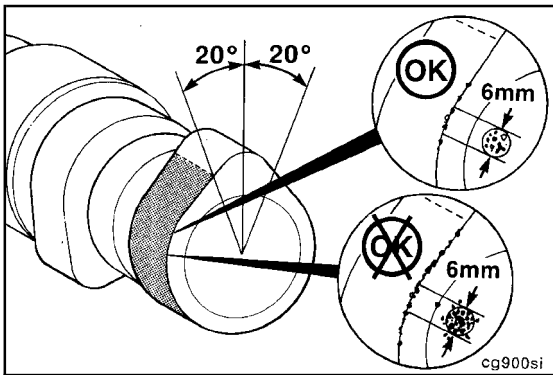

Outside of the  $\pm 20$  degrees of the nose of the cam lobe, the areas of edge deterioration should **not** be greater than the equivalent area of a 6-mm [0.236-in] circle.

The first of the following illustrations show normal grain pattern and a casting flaw within the nose area. Both of these conditions are acceptable for reuse.

The following three illustrations show wear patterns that are **not** acceptable for reuse.

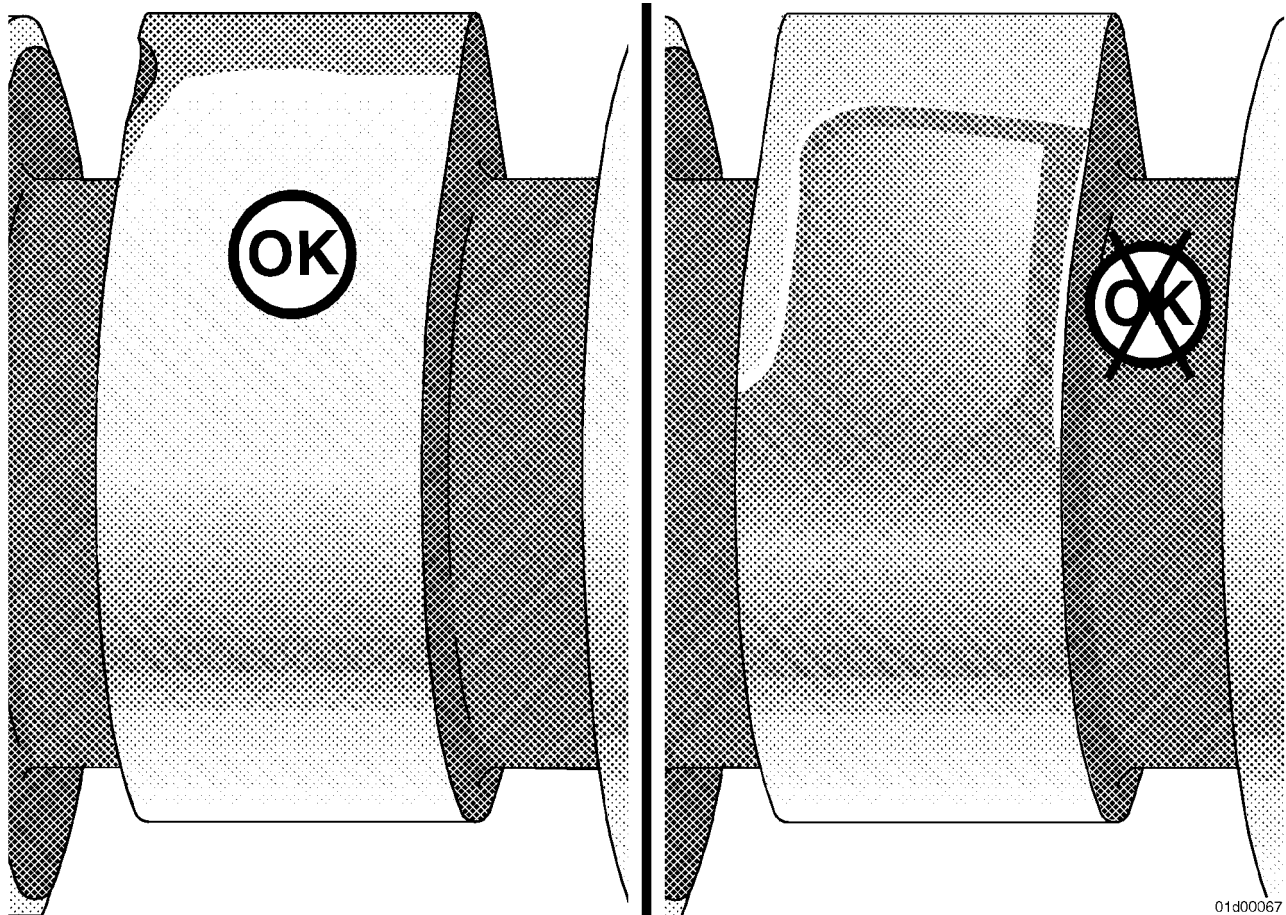

01d00067

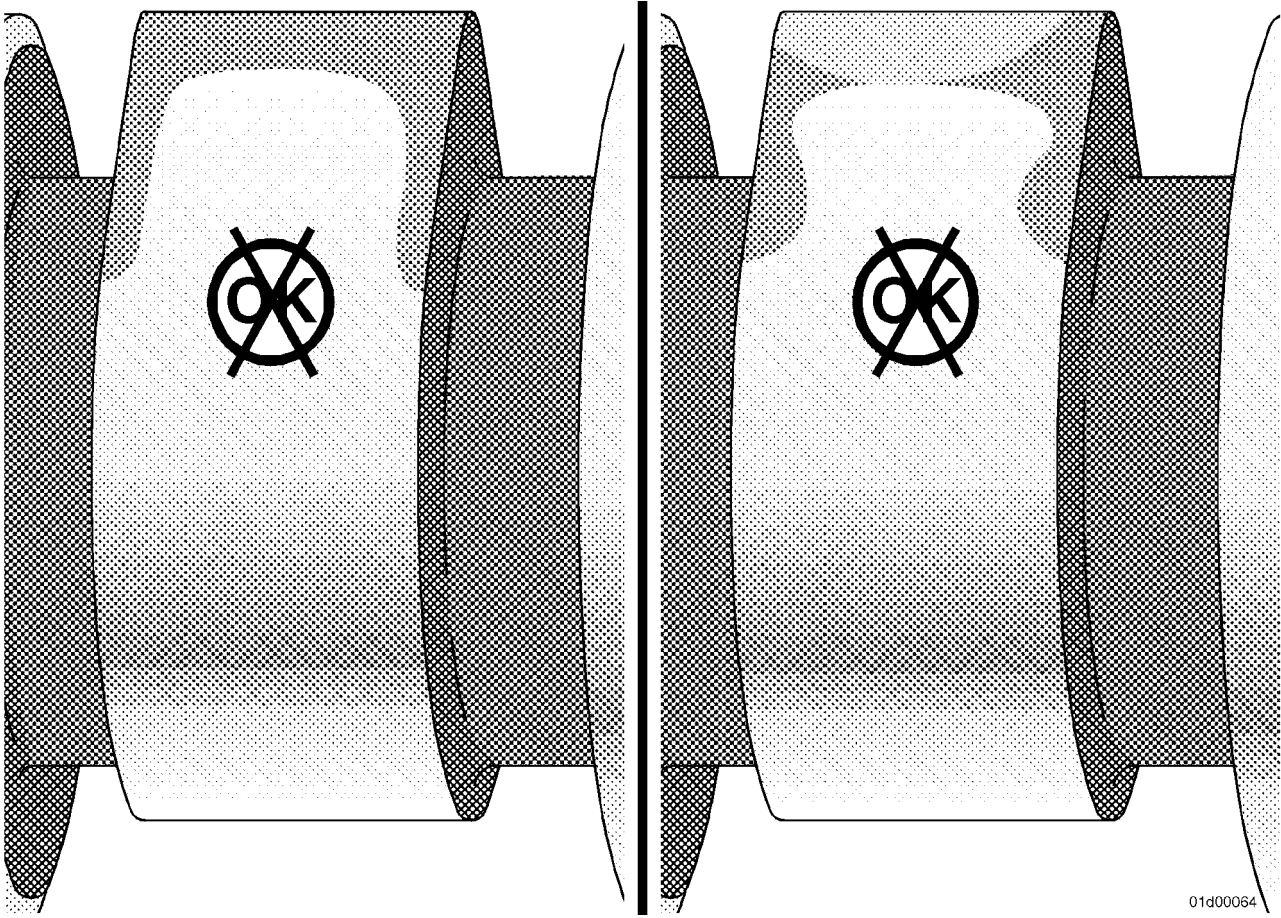

01d00064

**Camshaft Bore - Inspection**

Inspect the camshaft bore for obvious damage and excessive wear.

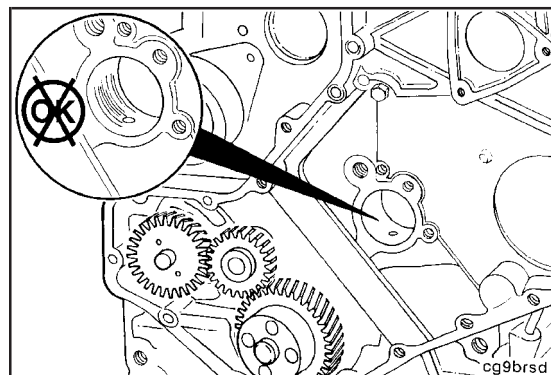

Measure the camshaft bore.

	Camshaft Bore Inside Diameter		
	mm		in
No. 1 Bushing	54.146	MAX	2.1317
All Except No. 1	54.164	MAX	2.1324

**NOTE:** If the bores without a bushing are worn beyond the limit, the engine **must** be removed for machining and installation of service bushings or replacement of the cylinder block.

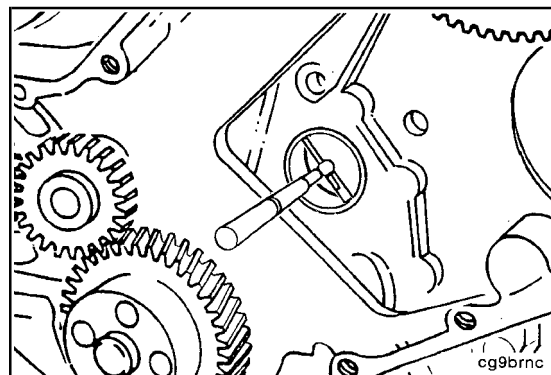

**Install (001-008-026)**

Apply a coat of clean lubricating engine oil to the front camshaft bore.

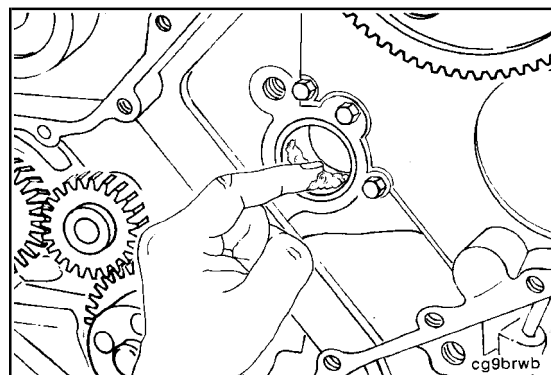

Lubricate the camshaft lobes, journals, and thrust washer with clean lubricating engine oil.

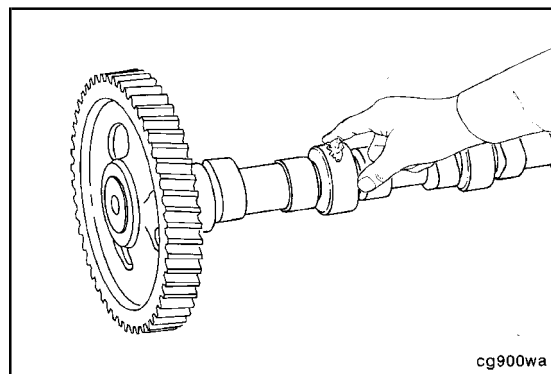

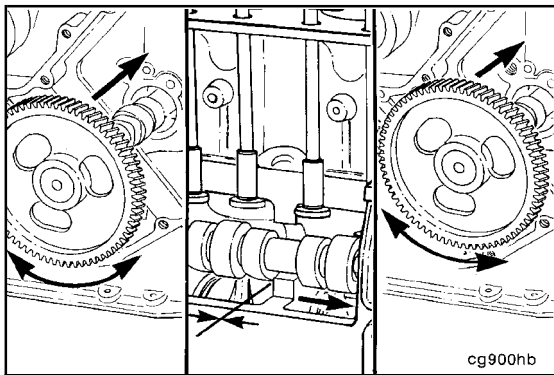

Install the camshaft. While pushing in slightly, rotate the camshaft and carefully work the camshaft through the camshaft bushings. As each camshaft journal passes through a bushing, the camshaft will drop slightly and the camshaft lobes will catch on the bushings. Rotating the camshaft will free the lobe from the bushing and allow the camshaft to be installed.

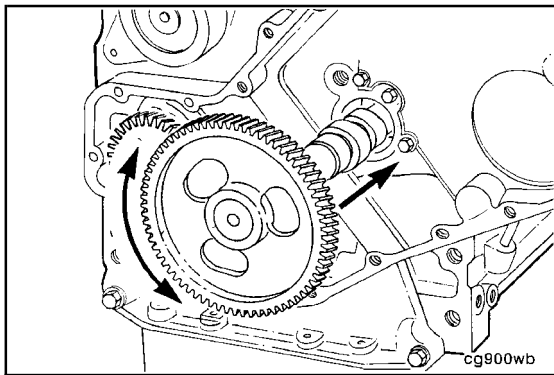

**⚠ CAUTION ⚠**

**Do not try to force the camshaft into the camshaft bore or damage to the camshaft bushing can result.**

Before the camshaft gear engages the crankshaft gear, check the camshaft for ease of rotation. When installed properly, the camshaft should rotate freely.

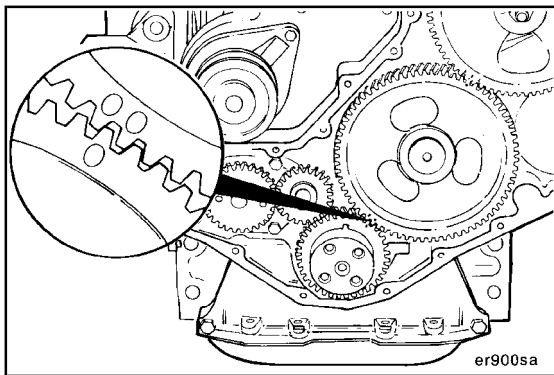

Install the thrust washer, align the timing marks as illustrated, and finish installing the camshaft.

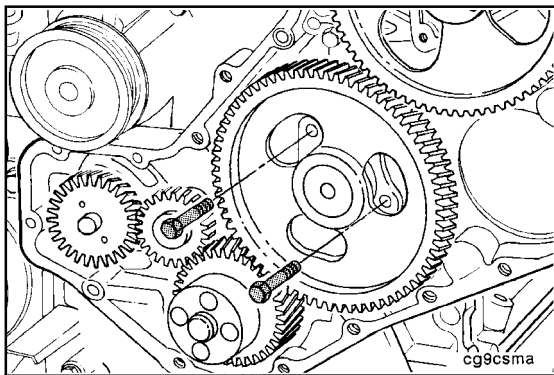

Install the thrust washer cap screws.

**Torque Value: 24 N•m [18 ft-lb]**





Verify that the camshaft has proper backlash and end play.

Camshaft End Play (A)		
mm		in
0.12	MIN	0.005
0.47	MAX	0.018

  

Camshaft Gear Backlash Limits (B)		
mm		in
0.330	MIN	0.013
0.76	MAX	0.030

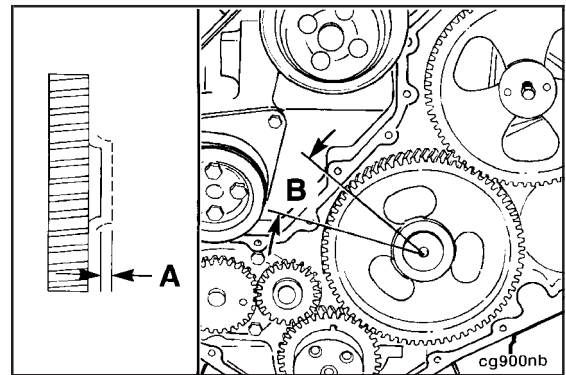

Complete the installation of the removed parts.

- Install the gear cover. Refer to Procedure 001-031.
- Install the vibration damper. Refer to Procedure 001-052.
- Install the drive belt. Refer to Procedure 008-002.
- Install the tappets. Refer to Procedure 004-015.
- Install the push tubes. Refer to Procedure 004-014.
- Install the rocker levers. Refer to Procedure 003-008.
- Adjust the valve lash. Refer to Procedure 003-004.
- Install the rocker lever cover. Refer to Procedure 003-011.
- Install fuel transfer pump. Refer to Procedure 005-045.
- Operate the engine at idle for 5 to 10 minutes, and check for leaks and loose parts.

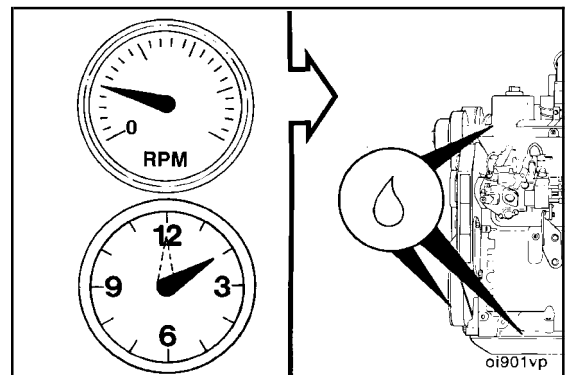
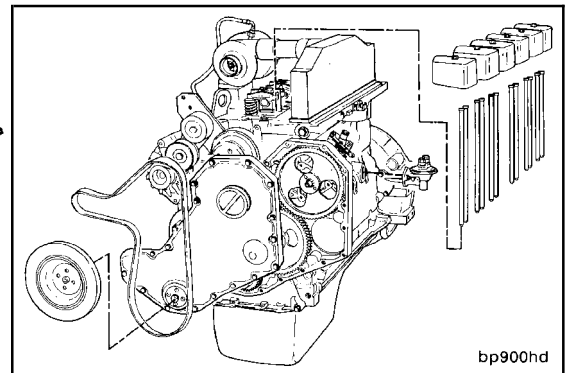

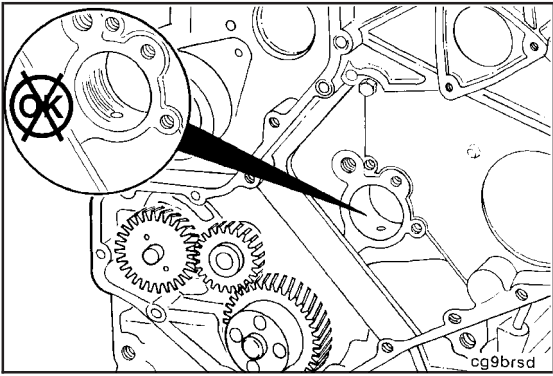

**Camshaft Bushings (001-010)**

**Initial Check (001-010-001)**

Inspect the camshaft bore for damage and excessive wear.

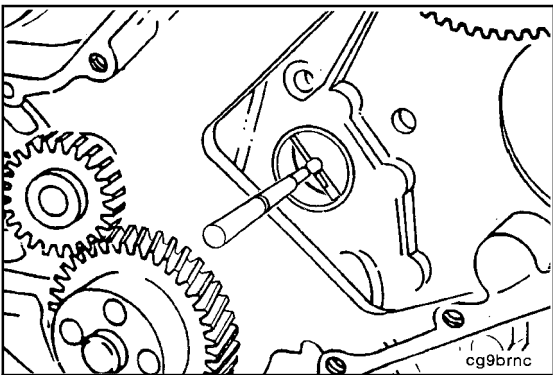

Measure the camshaft bore.

	Camshaft Bore Diameter (Maximum)		
	mm		in
Storm Block - No. 1 only (without bushing installed)	59.248	MAX	2.3326
Prestorm Block - No. 1 only (without bushing installed)	57.248	MAX	2.2539
No. 1 only (with bushing)	54.147	MAX	2.1318
No. 2 through No. 7	54.164	MAX	2.1324

**NOTE:** Camshaft bores No. 2 through 7 do **not** use a bushing.

**NOTE:** The introduction of the storm block increased the camshaft bushing bore diameter by 2 mm [0.079 in] to accept a larger outer diameter cam bushing. The camshaft inner diameter did **not** change.

**NOTE:** If the bores without a bushing are worn beyond the limit, the engine **must** be removed for replacement of the cylinder block.

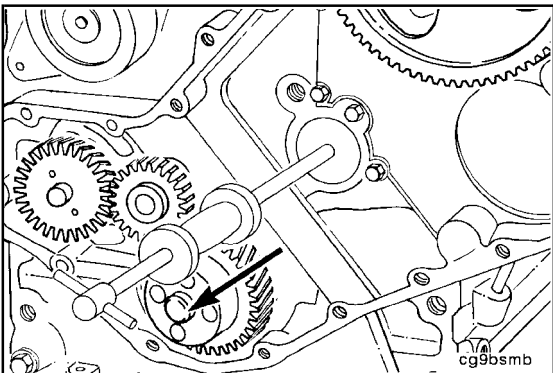

**Remove (001-010-002)**

**Camshaft Bushing Tool, Part No. 3823509**



Remove the camshaft bushing from the No. 1 bore.

Mark the camshaft bushing and cylinder block so you can align the lubricating oil hole in the cylinder block with the lubricating oil hole in the bushing.

**NOTE:** Make sure the bore in the cylinder block and the outside diameter of the bushing are clean from oil and dirt.

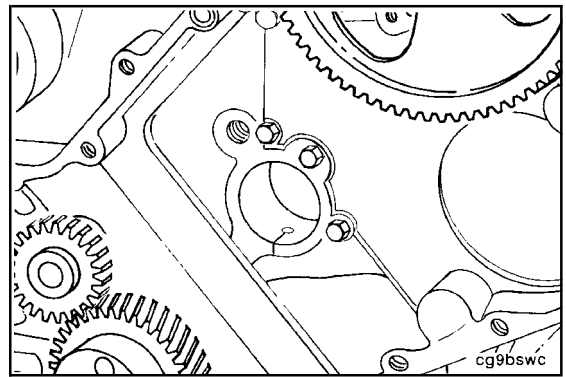

**Install (001-010-026)**

Apply Loctite primer to the outside diameter of the bushing and the inside of the camshaft bore of the cylinder block.

Allow the primer to dry.

Apply a bead of Loctite 609, or equivalent, to 270 degrees along the edge of the bushing that will be installed toward the rear of the cylinder block.

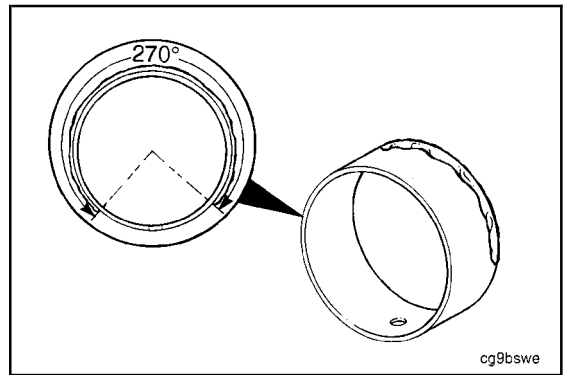

**⚠ CAUTION ⚠**

**Make sure there is no Loctite in the oil hole, or severe engine damage can result.**

Use extreme care **not** to apply Loctite to the oil hole in the bushing.

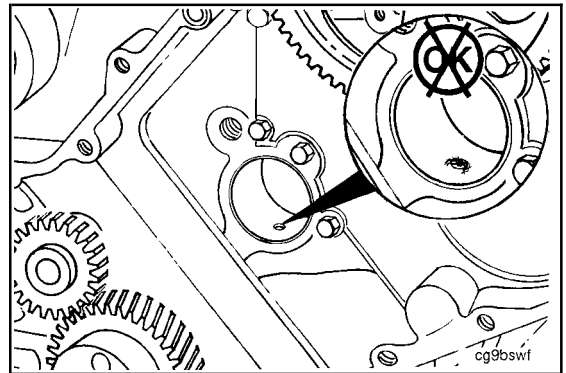

**Camshaft Bushing Tool, Part No. 3823509**

Install the camshaft bushing so that it is even with the front face of the cylinder block.

Use a clean, lint-free cloth to wipe off any excess Loctite.

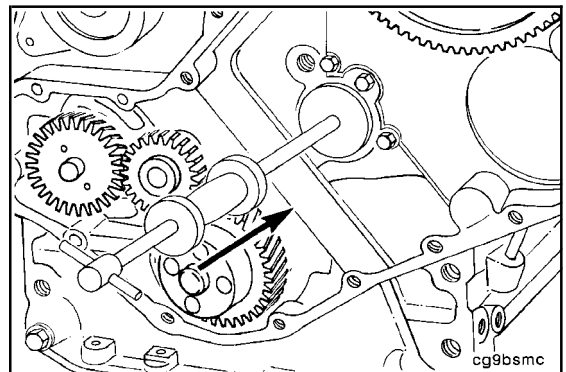

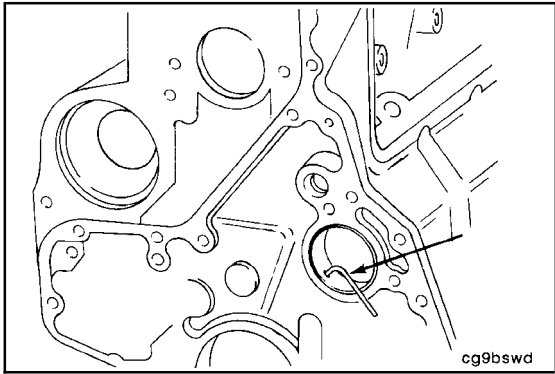

**CAUTION**

Make sure there is no Loctite in the oil hole, or severe engine damage can result.

Be sure the lubricating oil hole is aligned.

A 3.2-mm [0.126- in] diameter rod **must** be able to pass through the lubricating oil hole.

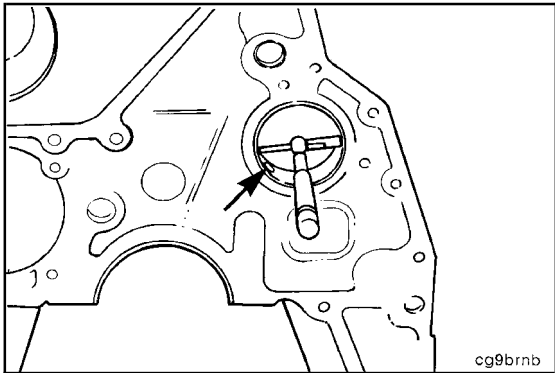

**Measure (001-010-010)**

Measure the installed camshaft bushing.

Camshaft Bore (Bushing Installed)		
mm		in
54.107	MIN	2.1302
54.146	MAX	2.1317

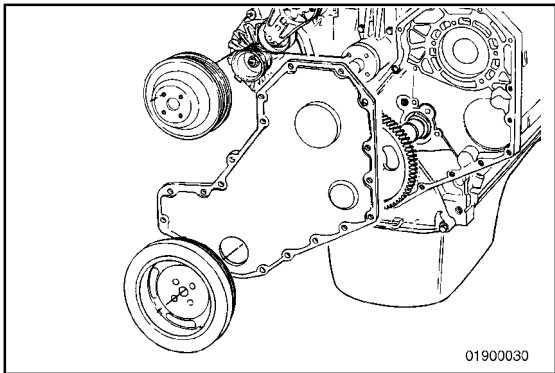

**Camshaft Gear (Camshaft Removed) (001-013)**



**Preparatory (001-013-000)**

A camshaft gear removal/installation tool, Part No. 3823589, is available for replacing the camshaft gear in restricted areas where the camshaft can **not** be removed from the engine. Follow the directions included with the tool.

Remove the fan pulley. Refer to Procedure 008-039.

Remove the vibration damper. Refer to Procedure 001-052.

Remove the gear cover. Refer to Procedure 001-031.

Remove the camshaft. Refer to Procedure 001-008.

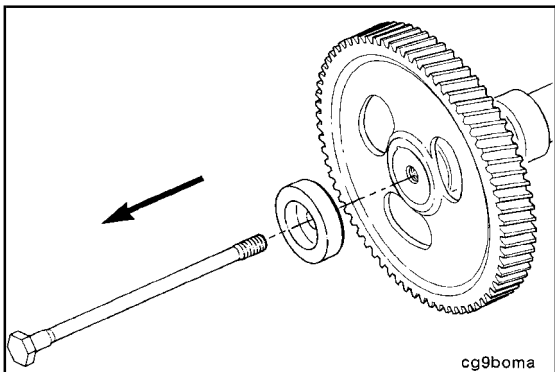

**Remove (001-013-002)**

18 mm



On bolted camshafts, remove the camshaft bolt and washer.

Bolted camshafts are **only** used on 1991 engines equipped with an in-line pump.

**⚠ CAUTION ⚠**

Place a wooden block under the camshaft to avoid damage as the camshaft drops free from the cam gear.

If the camshaft gear is **not** bolted, place the cam in a hydraulic press.

Press the gear on the camshaft.

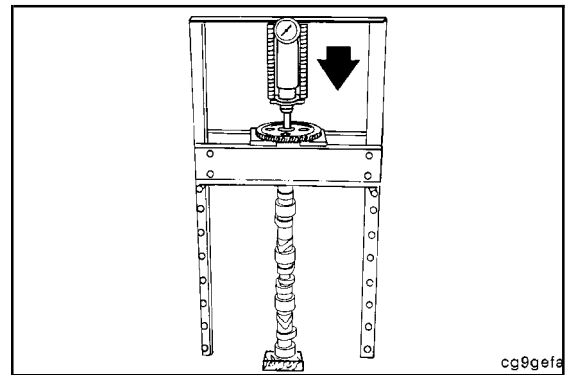

cg9gef

Remove the camshaft key.

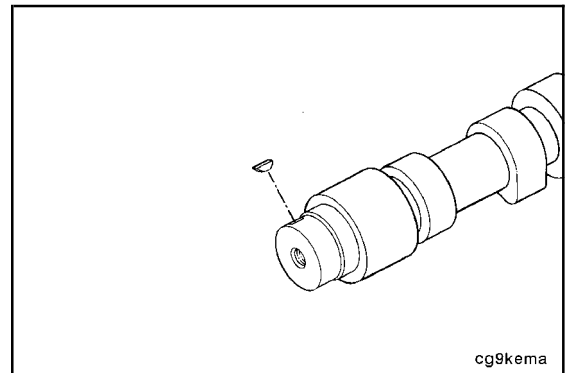

cg9kema

**Clean (001-013-006)**

**⚠ WARNING ⚠**

When using solvents, acid, or alkaline materials for cleaning, follow the manufacturer's recommendations for use. Wear goggles and protective clothing to avoid personal injury.

**⚠ WARNING ⚠**

Wear appropriate eye and face protection when using compressed air. Flying debris and dirt can cause bodily injury.

Use solvent to clean the camshaft gear.

Dry with compressed air.

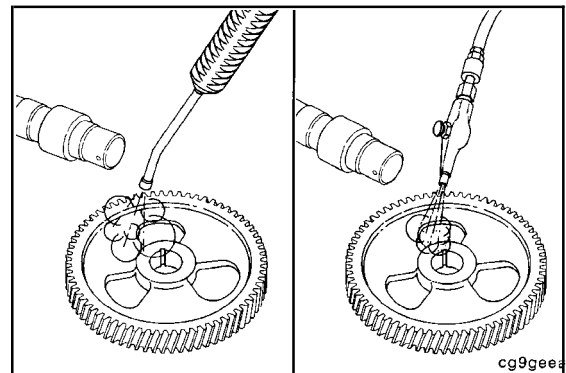

cg9gee

**Inspect for Reuse (001-013-007)**

Inspect the camshaft gear for cracked, chipped, or broken teeth.

Inspect the camshaft bore for frets or burrs.

**NOTE:** If the frets, burrs, or raised material can **not** be removed with Scotch-Brite 7448, or equivalent, replace the camshaft gear.

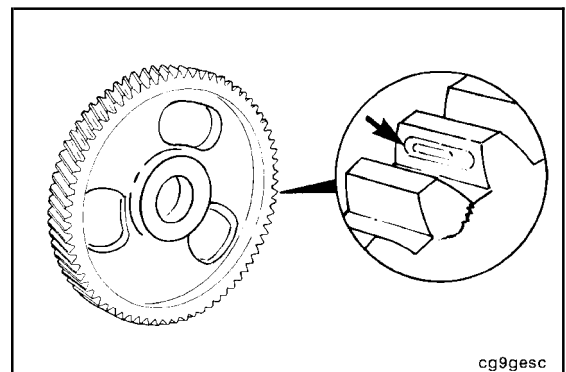

cg9gesc

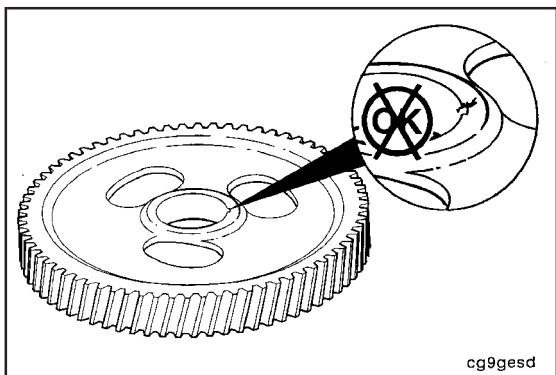

Inspect the camshaft gear keyway for burrs.

Remove burrs with Scotch-Brite™ 7448, or equivalent.



**NOTE:** If the keyway is damaged or the burrs can **not** be removed, the camshaft gear **must** be replaced.

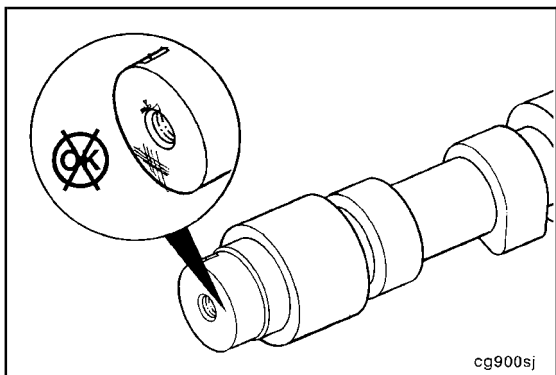

Inspect the camshaft nose for frets or burrs.

**NOTE:** If frets or burrs can **not** be removed with Scotch-Brite 7448, or equivalent, replace the camshaft.

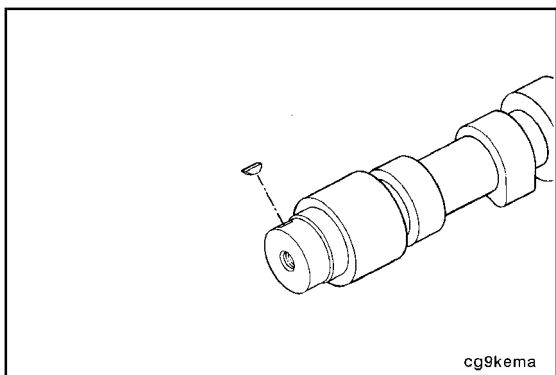

**Install (001-013-026)**

Use a leather hammer to install the Woodruff key.

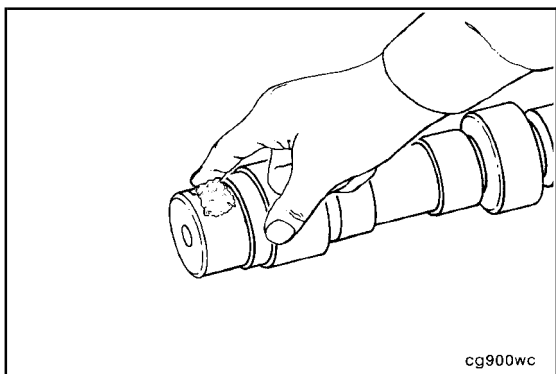

Lubricate the camshaft surface with clean lubricating engine oil.

**⚠ CAUTION ⚠**

The camshaft gear will be permanently distorted if overheated. The oven temperature should never exceed 177°C [350°F].

Heat the camshaft gear for **nonbolted** 1991 camshafts in an oven at 149°C [300°F] for 45 minutes.

Heat the camshaft gear for **bolted** 1991 camshafts (steel gear) and all 1994 automotive to 177°C [350°F].

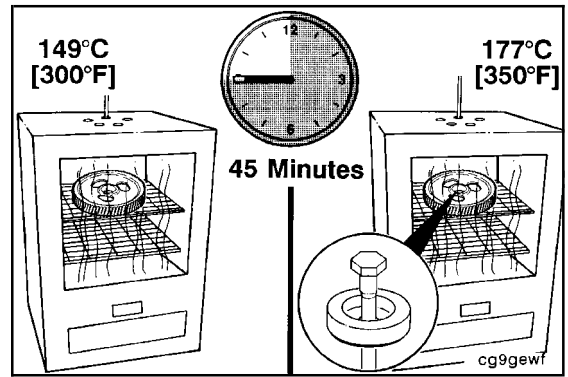

**⚠ WARNING ⚠**

Wear protective gloves to prevent personal injury when handling parts that have been heated.

Install the camshaft gear with the timing marks away from the camshaft.

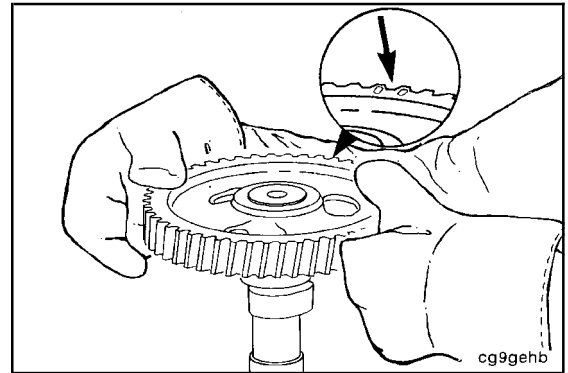

**⚠ CAUTION ⚠**

To prevent engine damage, the timing marks and gear part numbers must be facing away from the camshaft when the gear is installed. Keep the camshaft in a vertical position with the gear up until the gear has cooled. Do not use water to reduce the cooling time. Using water can crack the gear.

**NOTE:** The gear **must** be installed within 30 minutes after it is removed from the oven.

Remove the gear from the oven. Align the keyway in the gear with the dowel pin in the camshaft; install the gear on the camshaft. Make sure the gear is seated against the camshaft shoulder.

**NOTE:** Be sure the gear is seated against camshaft shoulder.

Using a 0.001-inch feeler gauge, check to see if the feeler gauge can be inserted between the camshaft gear and the shoulder on the camshaft. If the feeler gauge can be inserted, the camshaft gear is **not** properly seated.

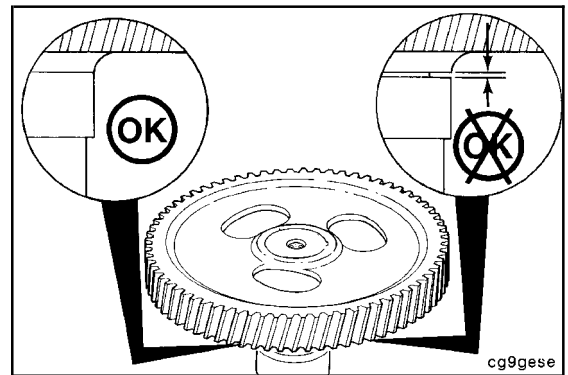
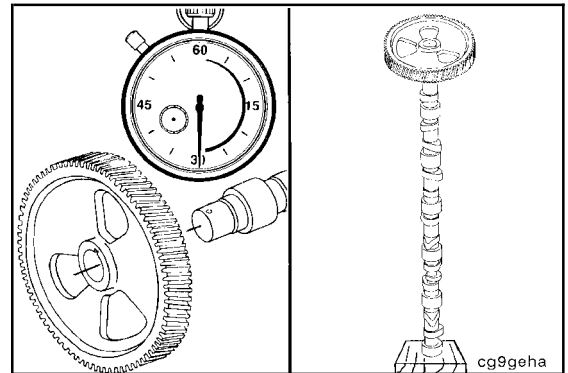

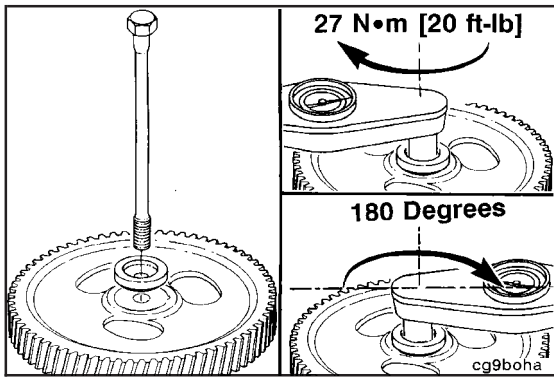

18 mm

Install camshaft bolt and washer in 1991 engines equipped with an in-line pump.



**Torque Value:** Step 1 27 N•m [20 ft-lb]  
Step 2 Turn capscrew clockwise 180 degrees.

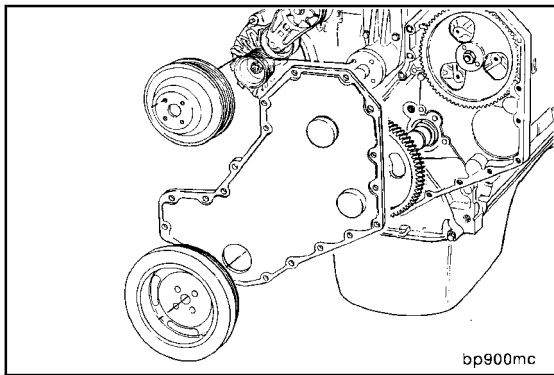

Install camshaft. Refer to Procedure 001-008.

Adjust the valve lash. Refer to Procedure 003-004.



Install gear cover. Refer to Procedure 001-031.

Install vibration damper. Refer to Procedure 001-052.

Install fan pulley. Refer to Procedure 008-039.

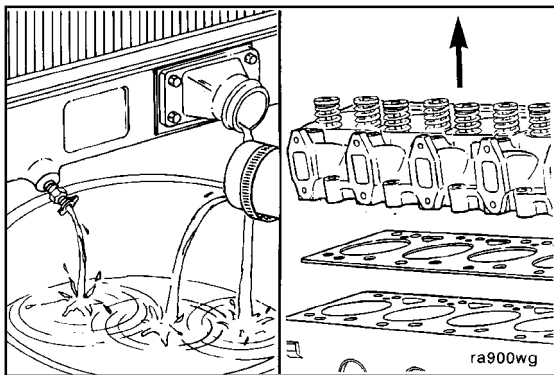

### Connecting Rod (001-014)

#### Preparatory (001-014-000)



Drain the coolant. Refer to Procedure 008-018.

Remove the cylinder head. Refer to Procedure 002-004.

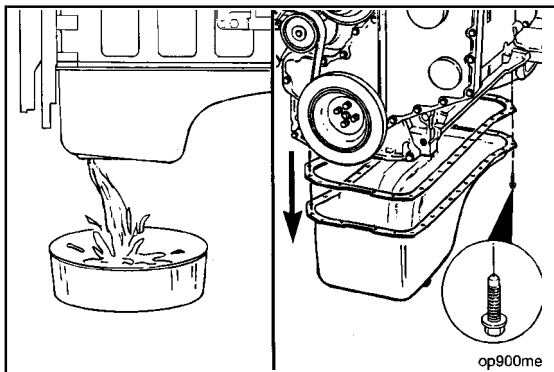

Drain the lubricating oil. Refer to Procedure 007-025.

Remove the lubricating oil pan and gasket. Refer to Procedure 007-025.





**Remove (001-014-002)**

Remove the piston and connecting rod assemblies from the engine. Refer to Procedure 001-054.

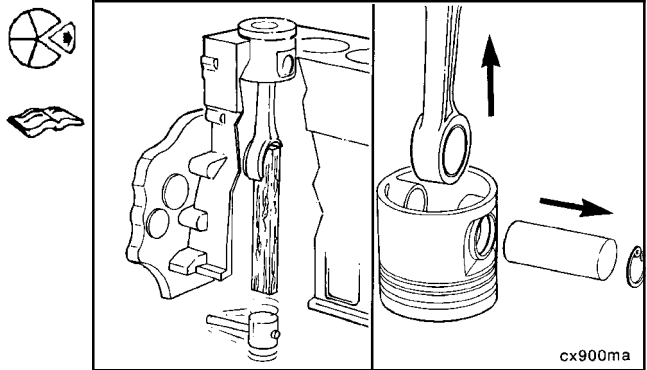

**Clean (001-014-006)**

**▲ WARNING ▲**

When using a steam cleaner, wear safety glasses or a face shield, as well as protective clothing. Hot steam can cause serious personal injury.

**▲ WARNING ▲**

When using solvents, acids, or alkaline materials for cleaning, follow the manufacturer's recommendations for use. Wear goggles and protective clothing to avoid personal injury.

**▲ WARNING ▲**

Wear appropriate eye and face protection when using compressed air. Flying debris and dirt can cause bodily injury.

Use a nylon bristle brush to clean the oil drillings.

Use steam or solvent to clean the connecting rods.

Dry with compressed air.

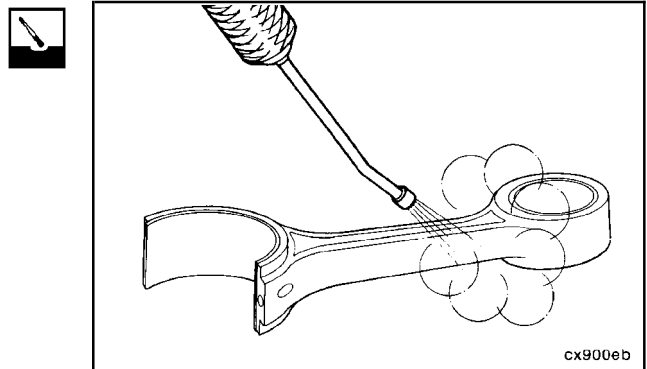

**Inspect for Reuse (001-014-007)**

Inspect the connecting rods and connecting rod caps for damage.

Replace the connecting rod if the "I-beam" is nicked or damaged.

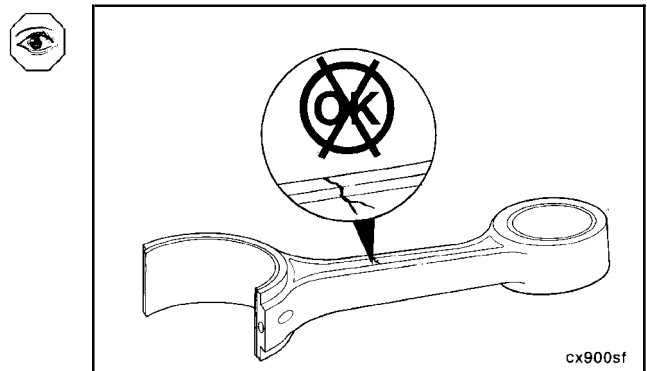

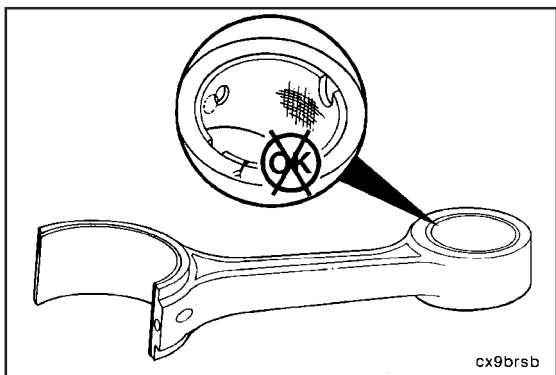

Inspect the piston pin bore for damage or misalignment of the oil passage and bushing.

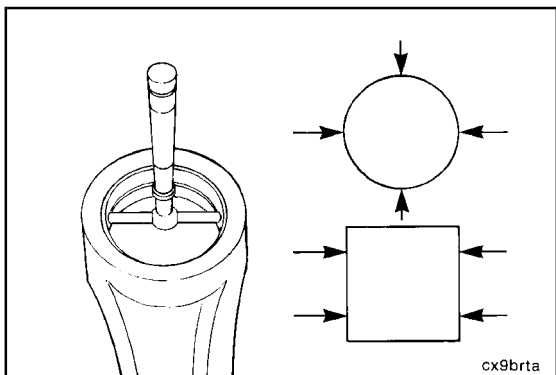

Measure the connecting rod piston pin bushing inside diameter.

Connecting Rod Piston Pin Bushing Diameter		
mm		in
40.019	MIN	1.5755
40.042	MAX	1.5765

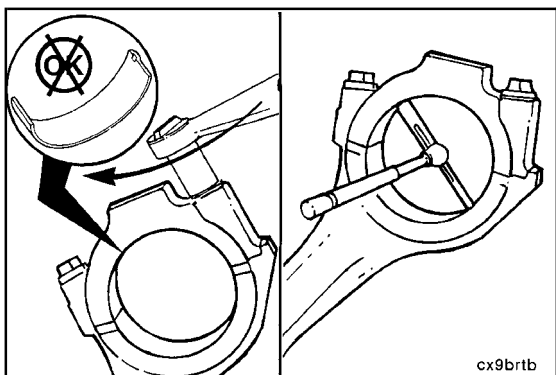

Measure the connecting rod crank bore with the bearing shells removed and the capscrews tightened.

**Torque Value:** 100 N•m [74 ft-lb]



Connecting Rod Crank Bore Diameter (Bearings Removed)		
mm		in
72.987	MIN	2.8735
73.013	MAX	2.8745

If the connecting rod crank-end bore measurements are **not** within specifications, replace the rod assembly.

**B3.9 and B5.9 Series Engines**  
**Section 1 - Cylinder Block - Group 01**

Measure the connecting rod crankshaft bore inside diameter with the bearings installed. Verify the torque of the capscrews.

**Torque Value:** 100 N•m [74 ft-lb]

Connecting Rod Bore Diameter (Bearings Installed)			
	mm		in
Standard	69.051	MIN	2.7185
	69.103	MAX	2.7205
0.25 mm Oversize	68.801	MIN	2.7087
	68.853	MAX	2.7107
0.50 mm Oversize	68.551	MIN	2.6989
	68.603	MAX	2.7009
0.75 mm Oversize	68.301	MIN	2.6890
	68.353	MAX	2.6911
1.00 mm Oversize	68.051	MIN	2.6792
	68.103	MAX	2.6812

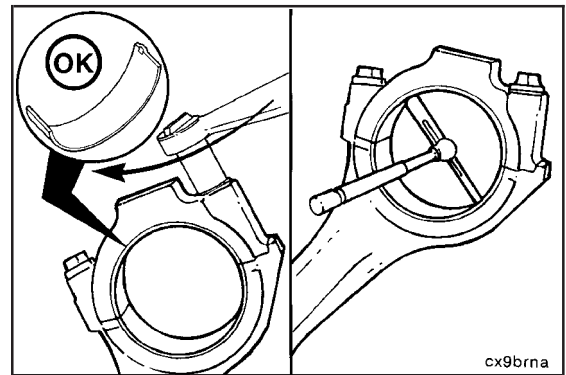

Measure the diameter of the rod journal on the crankshaft.

Crankshaft Rod Journal Diameter			
	mm		in
Standard	68.962	MIN	2.7150
	69.012	MAX	2.7170
0.25 mm Undersize	68.712	MIN	2.7052
	68.762	MAX	2.7072
0.50 mm Undersize	68.462	MIN	2.6953
	68.512	MAX	2.6973
0.75 mm Undersize	68.212	MIN	2.6855
	68.262	MAX	2.6875
1.0 mm Undersize	67.952	MIN	2.6753
	69.012	MAX	2.7170

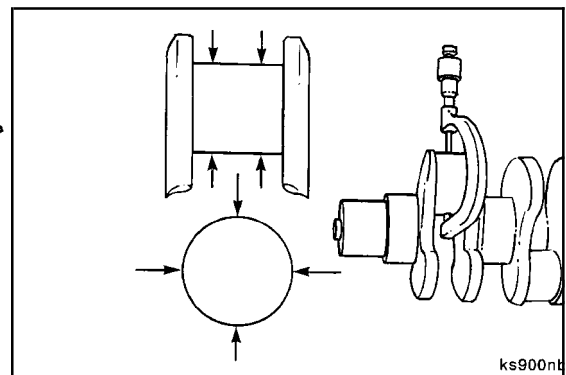

**NOTE:** If crankshaft rod journals are **not** within the given specifications, the crankshaft **must** be removed and reground.

Bearing clearance equals rod inside diameter (with bearing)(1) minus the crankshaft journal diameter (2).

Bearing Clearance			
mm			in
0.038	MIN		0.0015
0.116	MAX		0.0046

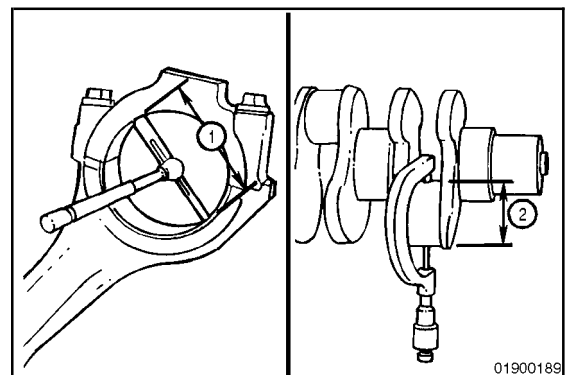

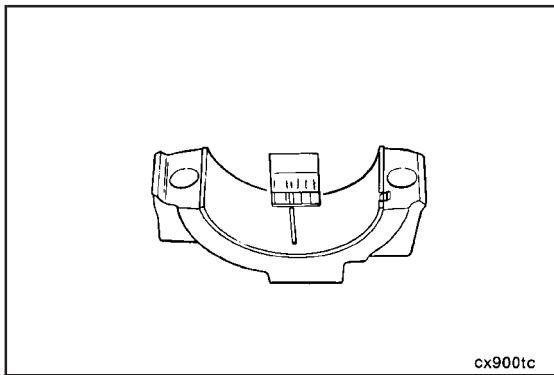

Bearing clearance can also be determined with Plastigauge during engine assembly.

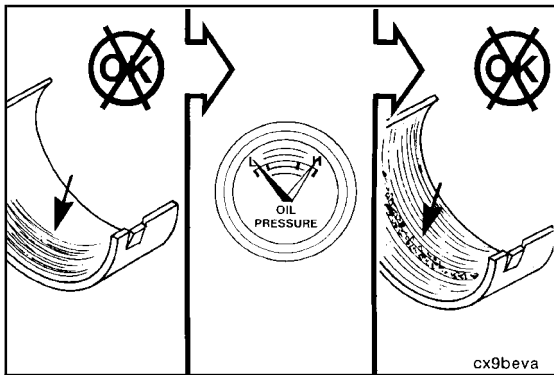

**Test (001-014-012)**

**Crankshaft and Main Bearings**

Improper maintenance of the lubrication system is also the primary cause of reduced main bearing life.

A malfunction of the crankshaft/main bearing will usually be detected by reduced lubricating oil pressure. If the rod bearings continue operation with low-lubricating oil pressure, this will lead to a rapid deterioration of the bearings and eventually will produce a knocking sound.

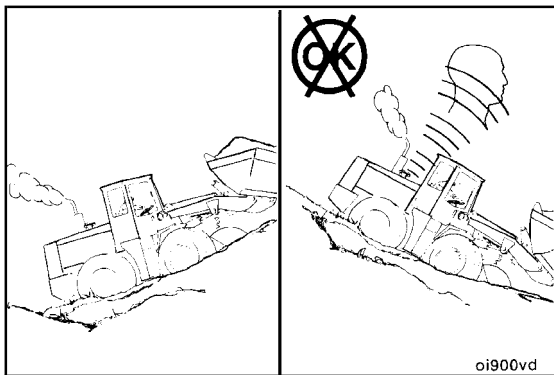

A connecting rod knock occurs when the engine is **not** loaded. Verify by first applying load and then unloading and listening for the knock.

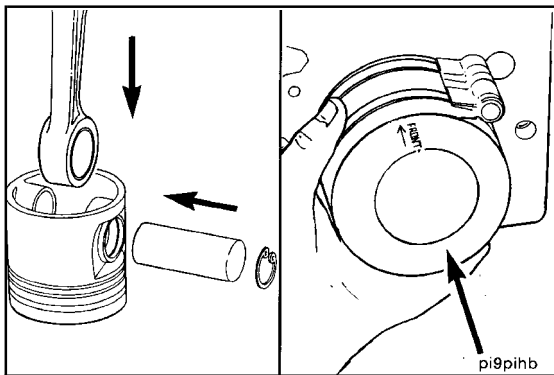

**Install (001-014-026)**

Install the pistons and connecting rod assemblies. Refer to Procedure 001-054.



**B3.9 and B5.9 Series Engines**  
**Section 1 - Cylinder Block - Group 01**

Install lubricating oil pan and gasket. Refer to Procedure 007-025.

**Torque Value:** 24 N•m [18 ft-lb]

Install the cylinder head. Refer to Procedure 002-004.

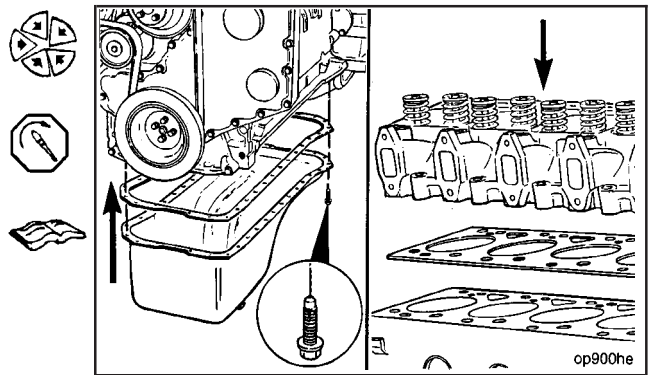

Fill the lubricating oil pan. Refer to the Operation and Maintenance Manual, B Series Engines, Bulletin No. 3810205 for the correct lubrication oil specification.

Fill the cooling system. Refer to Procedure 008-018.

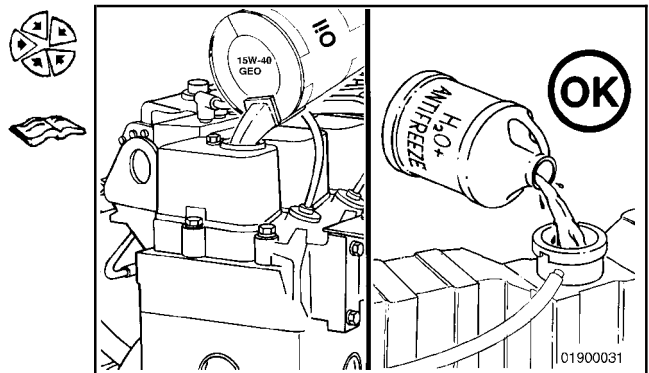

Operate the engine to normal operating temperature, and check for leaks.

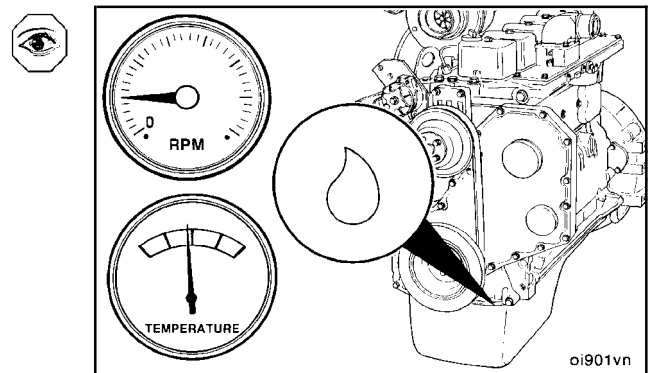

**Crankshaft (001-016)**

**General Information**

The crankshaft is a balanced, forged-steel unit. Four-cylinder engines have five main bearings. Six-cylinder engines have seven main bearings. The lower bearing shells are all the same. All of the upper bearing shells are also the same with the exception of the journal adjacent to the rear one. The next to last journal is fitted with a flanged upper bearing shell. The flanges control the end thrust of the crankshaft.

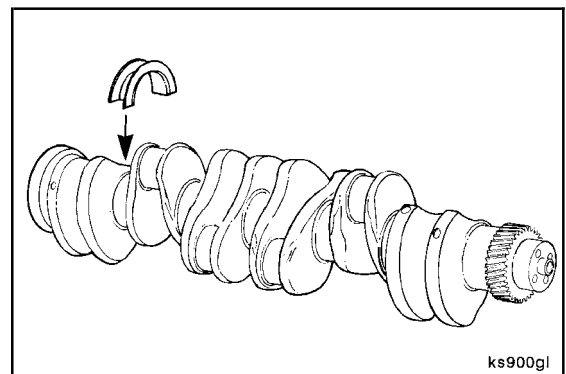

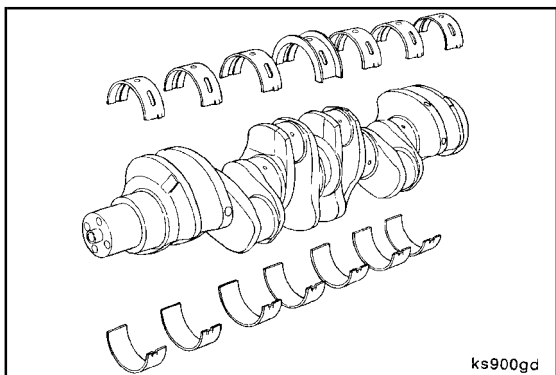

The crankshaft uses forged counterweights.

Oversize main bearings and thrust bearings are available for service. Cummins Engine Company, Inc., recommends regrinding **all** of the main or the connecting rod journals when one requires regrinding. Refer to the B Series Shop Manual, Bulletin No. 3666017.

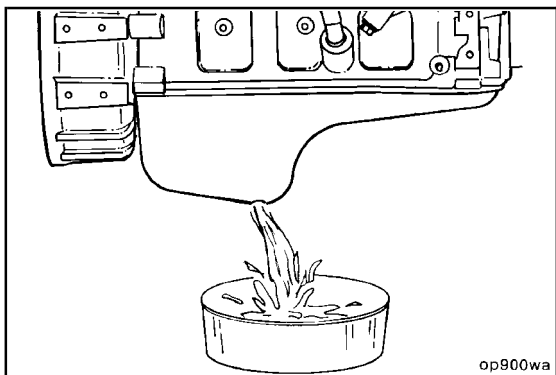

**Preparatory (001-016-000)**

**▲ WARNING ▲**



Some state and federal agencies have determined that used engine oil can be carcinogenic and cause reproductive toxicity. Avoid inhalation of vapors, ingestion, and prolonged contact with used engine oil.

Drain the lubricating oil; refer to Procedure 007-025.

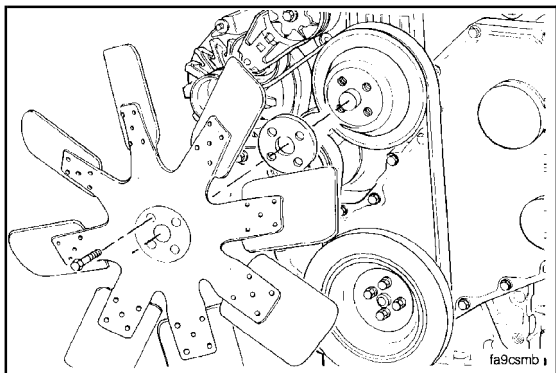

Remove the fan pulley.

Refer to Procedure 008-039.

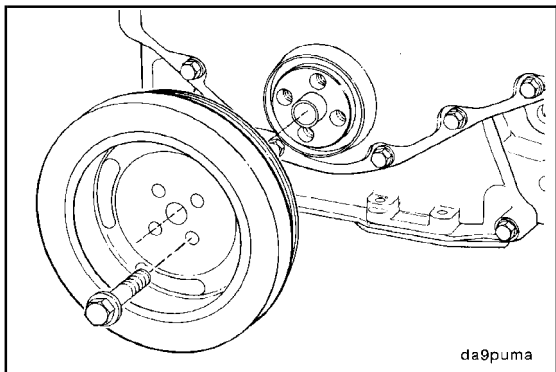

Remove the vibration damper.

Refer to Procedure 001-052.



Remove the front gear cover.  
Refer to Procedure 001-031.

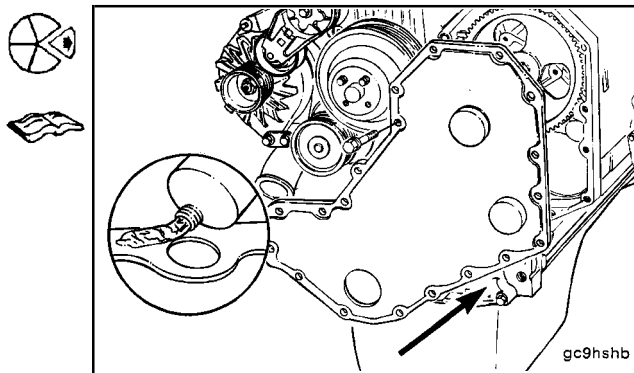

Remove the lubricating oil pan.  
Refer to Procedure 007-025.

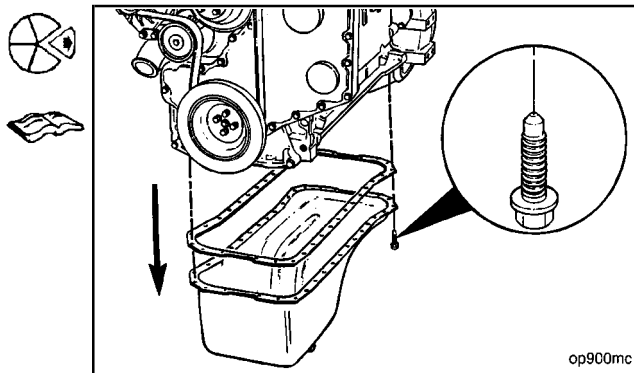

Remove the main bearings.  
Refer to Procedure 001-006.

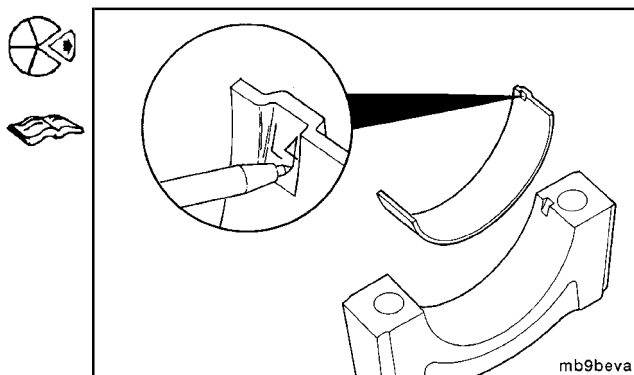

**Remove (001-016-002)**



**WARNING**

**This component weighs 23 kg [50 lb] or more. To avoid personal injury, use a hoist or get assistance to lift this component.**

**Nylon Lift Sling, Part No. 3375957**

**NOTE:** Lift the crankshaft straight up to avoid damage to the crankshaft and cylinder block.

Install nylon lift sling, Part No. 3375957, around the No. 3 and No. 4 rod bearing journals.

Attach the sling to a hoist, remove the crankshaft.

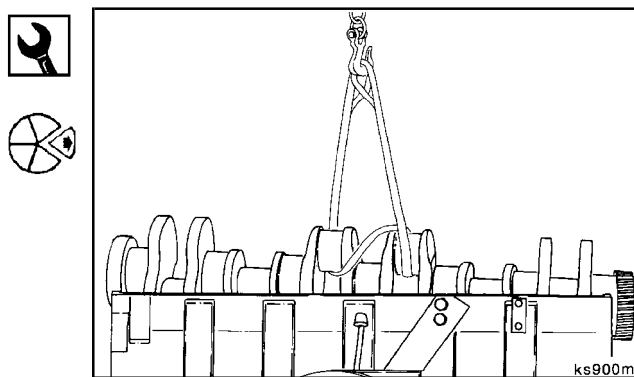

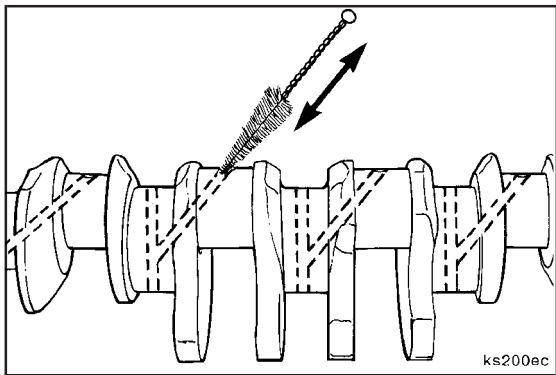

**Clean (001-016-006)**

Use fine crocus cloth to polish the machined surfaces.  
Use a bristle brush to clean the oil drillings.

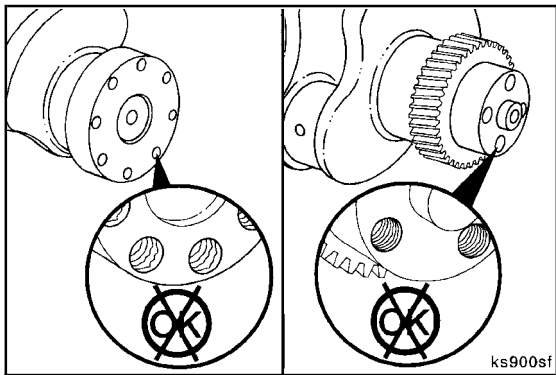

**Inspect for Reuse (001-016-007)**

Inspect the threaded capscrew holes for damage.

Use one of the following methods to repair any threaded holes:

- Chase the threads
- Use the threaded insert kit, Part No. 3822709.

**NOTE:** If more than two threaded holes are damaged in one end, the crankshaft **must** be replaced.

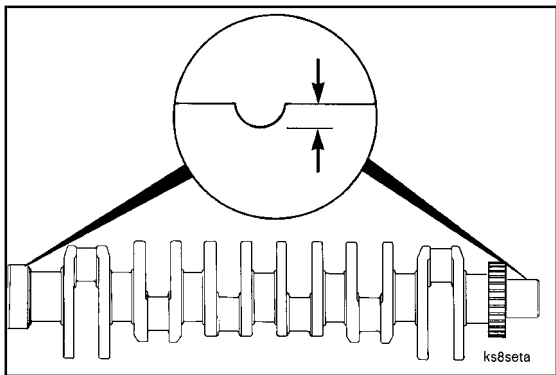

Measure the front and rear oil seal contact areas for a wear groove.

Crankshaft Front and Rear Oil Seal Wear Groove		
mm		in
0.25	MAX	0.010

Front and rear wear sleeves are available for a crankshaft that is worn beyond the limit.

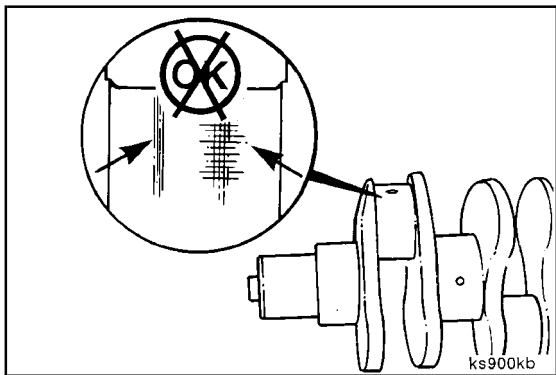

Inspect the crankshaft connecting rod and main journals for deep scoring, overheating, etc.



Use a micrometer to measure the connecting rod journal.



Connecting Rod Bearing Journal Diameter			
	mm		in
Standard	68.987	MIN	2.716
Machined 0.25 mm	68.737	MIN	2.706
Machined 0.50 mm	68.487	MIN	2.696
Machined 0.75 mm	68.237	MIN	2.687
Machined 1.00 mm	67.987	MIN	2.677

**Bearing Clearance** = Connecting rod inside diameter with bearing installed minus crankshaft journal diameter.

**Maximum Bearing Clearance:** 0.117 mm [0.0046 in].

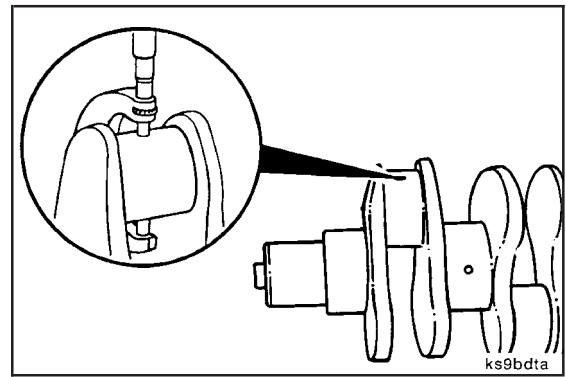

Connecting Rod Bearing Journal			
	mm		in
Out-of-Roundness	0.050	MAX	0.0020
Taper	0.013	MAX	0.0005

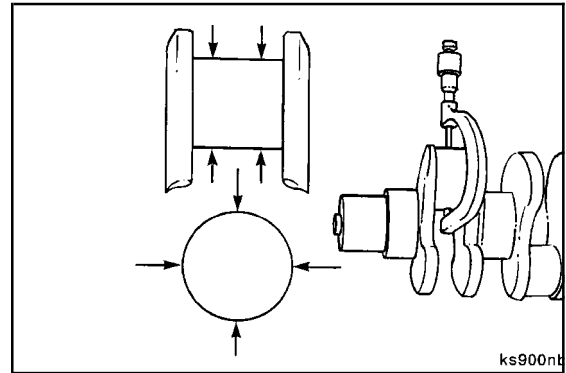

Main Bearing Journal Diameter			
	mm		in
Standard	82.987	MIN	3.267
Machined 0.25 mm	82.737	MIN	3.257
Machined 0.50 mm	82.487	MIN	3.248

**Bearing Clearance** = Main bore diameter with bearing installed minus (-) crankshaft main journal diameter.

**Maximum Bearing Clearance:** 0.13 mm [0.005 in].

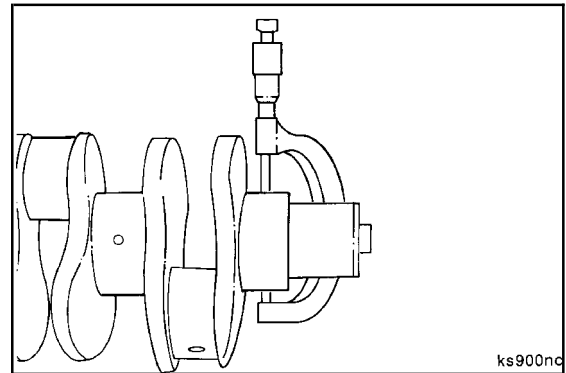

Crankshaft Main Bearing Journal			
	mm		in
Out-of-Roundness	0.05	MAX	0.0020
Taper	0.01	MAX	0.0004

The following oversize service main and thrust bearings are available for crankshafts that have been machined undersize:

	Thrust Size			
	Oversize	0.000	0.25 mm	0.50 mm
Journal Diameter	0.000	X	X	X
	0.25 mm	X	X	
	0.50 mm	X		X
	0.75 mm	X		
	1.00 mm	X		

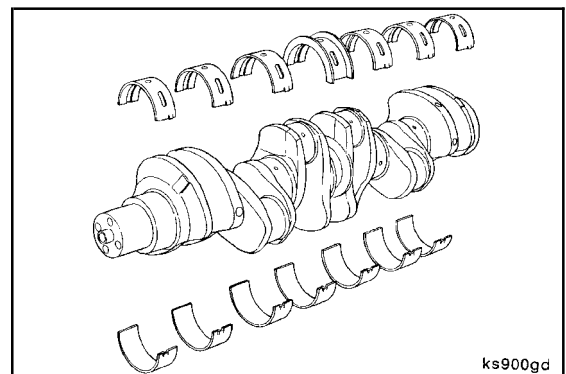

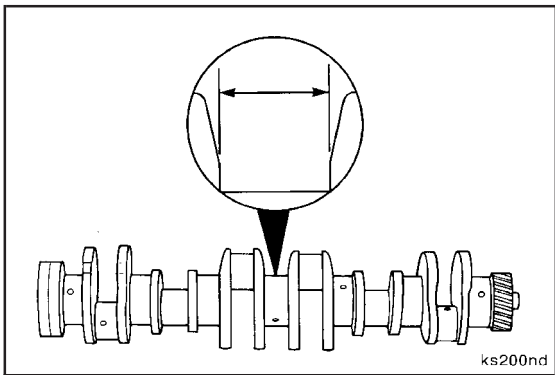

Measure the thrust face width.

Crankshaft Thrust Face Width (Standard)		
mm		in
42.98	MIN	1.692
43.08	MAX	1.696

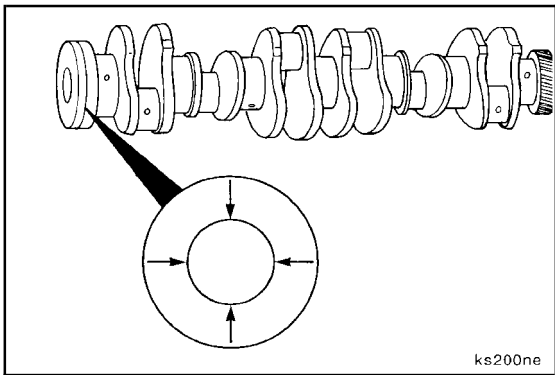

Measure the rear oil seal flange outside diameter.

Crankshaft Rear Oil Seal Flange Outside Diameter		
mm		in
129.98	MIN	5.117
130.03	MAX	5.119

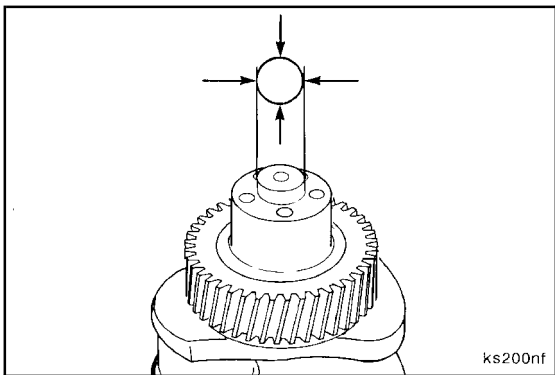

Measure the damper pilot outside diameter.

Crankshaft Damper Pilot Outside Diameter		
mm		in
18.924	MIN	0.745
19.00	MAX	0.748

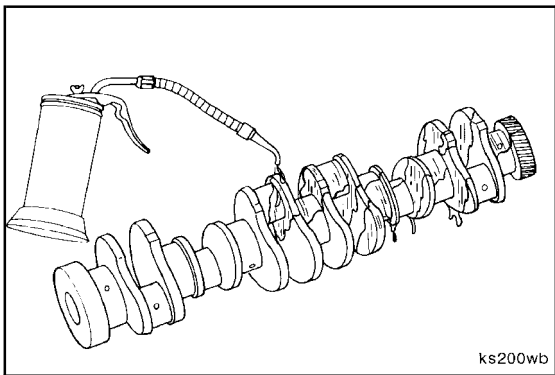

**Install (001-016-026)**

Use a light preservative oil to lubricate the crankshaft to prevent rust.

**NOTE:** If the crankshaft is **not** going to be used immediately, protect the part with a plastic cover to prevent dirt from sticking to the oil.

Install the upper main bearings.  
Refer to Procedure 001-006.

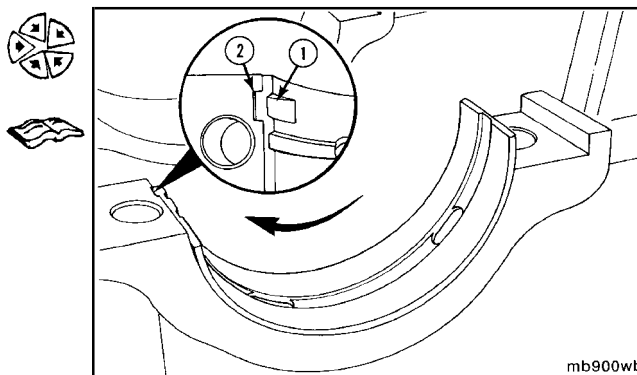

Install the upper thrust bearing.  
Refer to Procedure 001-006.

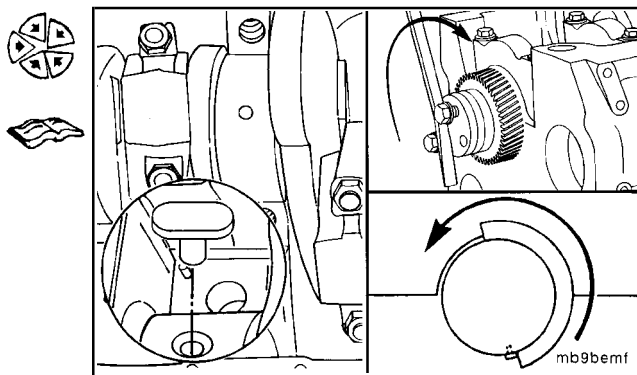

**⚠ WARNING ⚠**

**This component weighs 23 kg [50 lb] or more. To avoid personal injury, use a hoist or get assistance to lift this component.**

Use a hoist and nylon lift sling, Part No. 3375957.

Install the sling around the No. 3 and No. 4 connecting rod bearing journals.

Install the crankshaft.

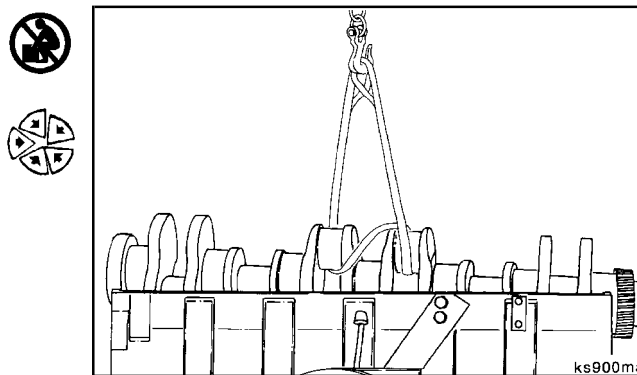

Install the lower main bearing.  
Refer to Procedure 001-006.

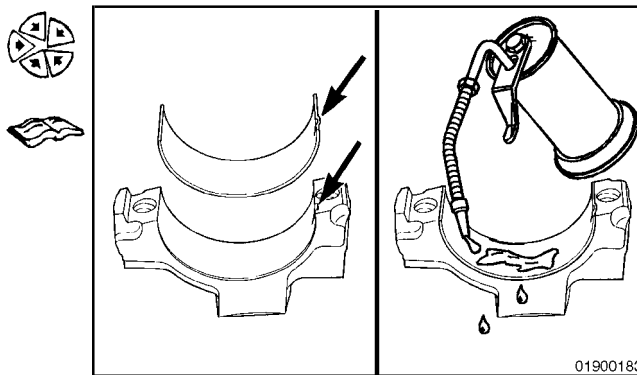

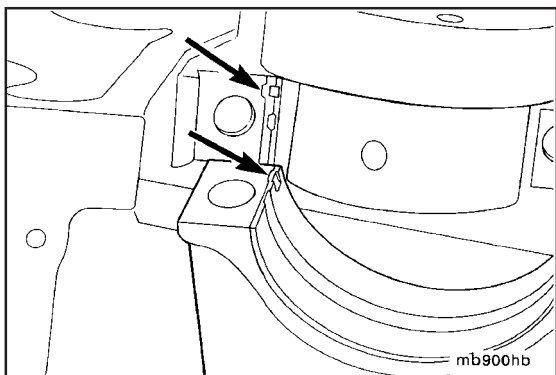

**NOTE:** The main bearing caps are numbered for location. No. 1 starts with the front of the cylinder block and the numbers **must** face the camshaft side of the engine.

When installed correctly, the main bearing tangs should both be on the same side.

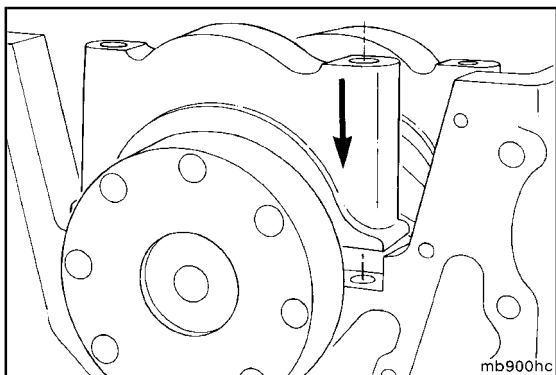

Position the main bearings and main bearing caps onto the crankshaft.

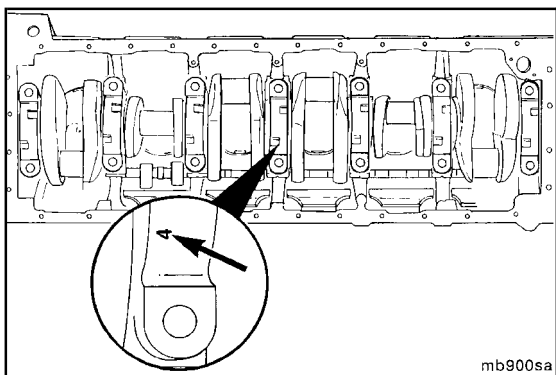

The thrust bearing journal does **not** have tangs or slots. Care **must** be taken to make sure the number stamped on the main bearing cap is positioned to the camshaft side of the engine.

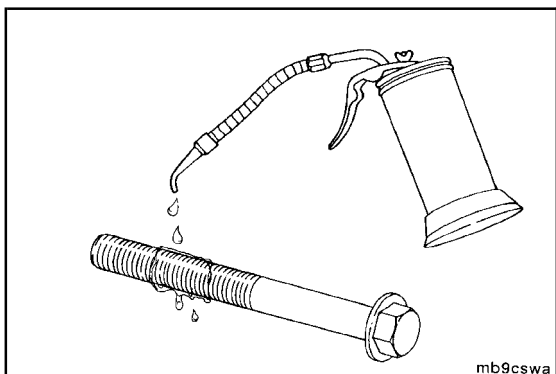

Lubricate the main bearing cap screw threads and under-side of the cap screw head with clean lubricating engine oil.

Tap the main bearing cap gently into position.

**NOTE:** Make sure the main bearing is still aligned with the cap.

When seated, the main bearing capscrews can be threaded in by hand.

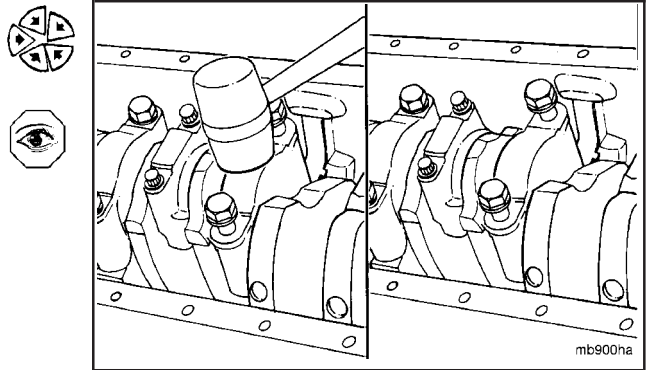

Tighten the main bearing capscrews evenly following the illustrated sequence.

- Torque Value:**
- |        |                           |            |
|--------|---------------------------|------------|
| Step 1 | 60 N•m                    | [44 ft-lb] |
| 2      | 90 N•m                    | [66 ft-lb] |
| 3      | Turn clockwise 90 degrees |            |

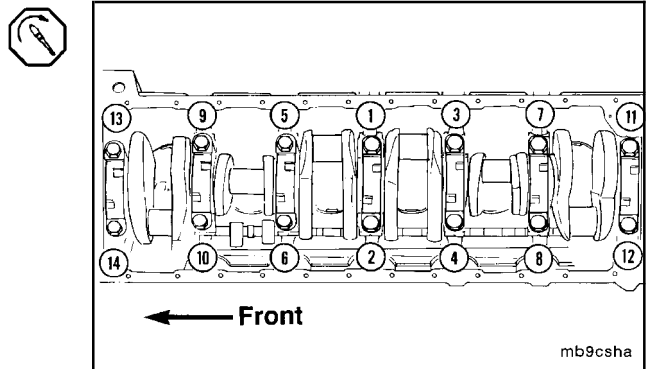

**NOTE:** The crankshaft **must** rotate freely after the main bearings have been installed.

Inspect the main bearing installations and the size of the main bearings if the crankshaft will **not** rotate freely.

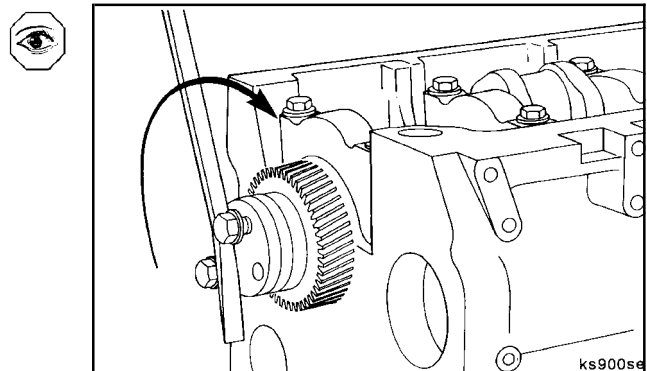

**Rotation Check (001-016-052)**

**Barring Tool, Part No. 3824591**

The barring tool inserts into the flywheel housing and engages the flywheel ring gear. The crankshaft can then be rotated by hand using a 1/2-inch-drive ratchet or breaker bar.

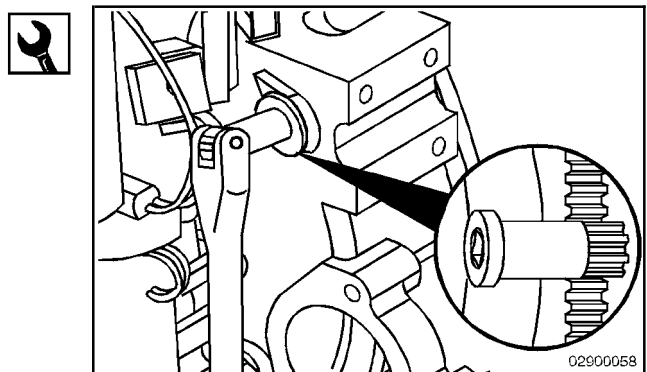

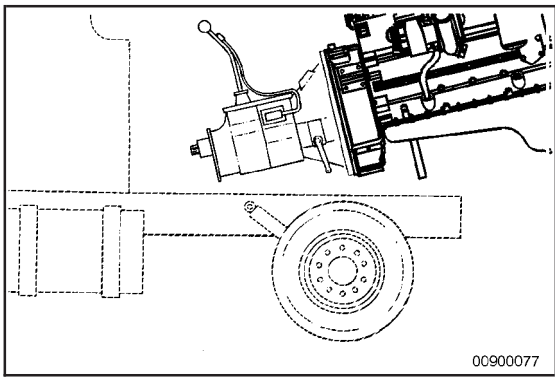

## Crankshaft Gear, Front (Crankshaft Installed) (001-018)

### General Information

The crankshaft gear can **not** be removed in-chassis. To remove crankshaft gear, refer to B Series Engine Shop Manual, Bulletin No. 3810206.

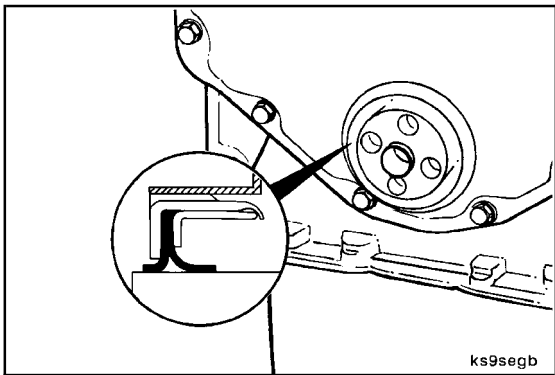

## Crankshaft Seal, Front (001-023)

### General Information

#### Front Crankshaft Seal

The front crankshaft seal is mounted in the front gear cover. A double-lipped Teflon™ seal is used. The sealing surface on the crankshaft **must** be clean and free of lubricating oil during assembly.

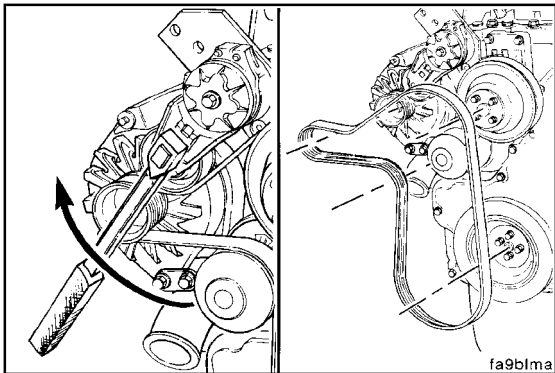

### Remove (001-023-002)

Remove the drive belt. Refer to Procedure 008-002.



**NOTE:** Removal is easier if the vibration damper is loosened before removing the belt.

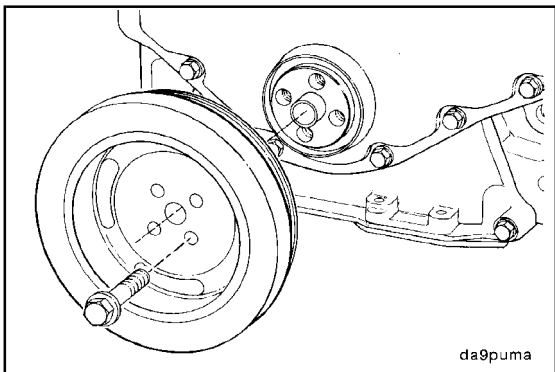

15 mm

Remove the vibration damper. Refer to Procedure 001-052.



Remove the front gear cover. Refer to Procedure 001-031.

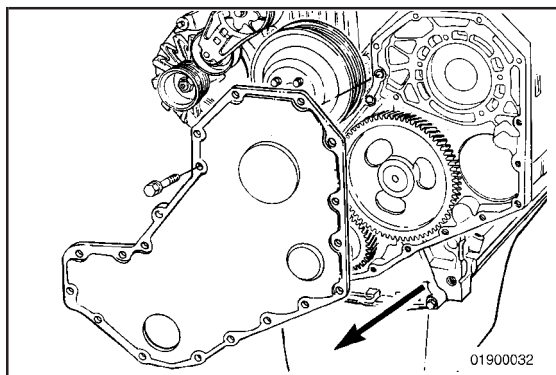

While supporting the gear cover, remove the oil seal from the gear cover. Drive the oil seal from the backside of the cover toward the frontside of the cover.

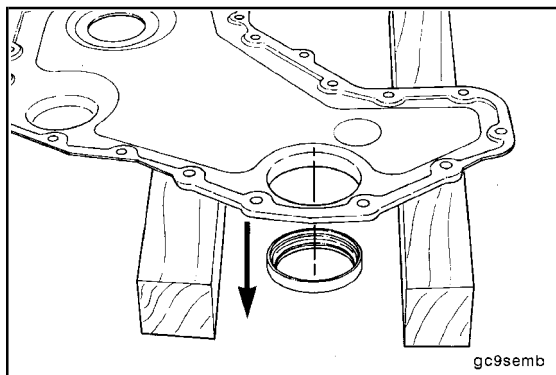

**Clean (001-023-006)**

Clean the gear cover seal bore and the crankshaft surface of all oil, dirt, and seal residue.

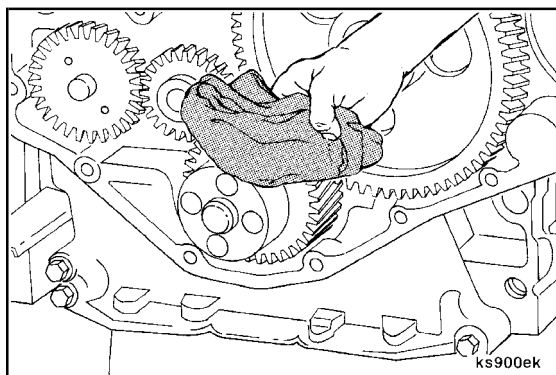

**Inspect for Reuse (001-023-007)**

Inspect the crankshaft for excessive wear.

**NOTE:** If the crankshaft has excessive wear, a service wear sleeve is available.

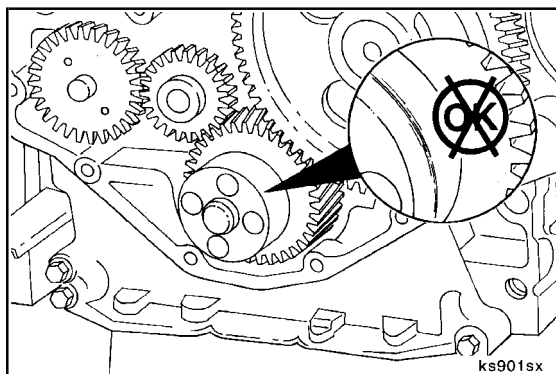

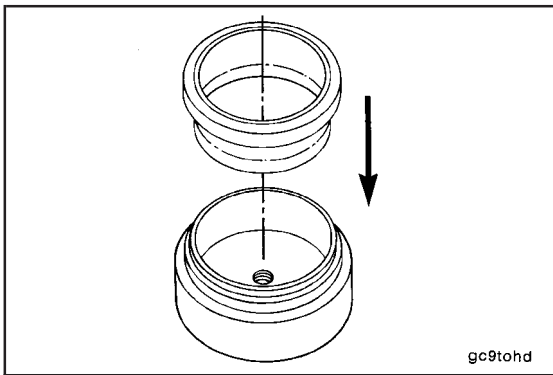

**Install (001-023-026)**

**Oil Seal Installation Tool, Part No. 3824498**



Leave the plastic pilot installation tool in the lubricating oil seal.

Position the seal on the service tool, Part No. 3824498, with the lubricating oil seal dust lip facing outward.

Apply a bead of Loctite 277, or equivalent, to the outside diameter of the seal before installation.

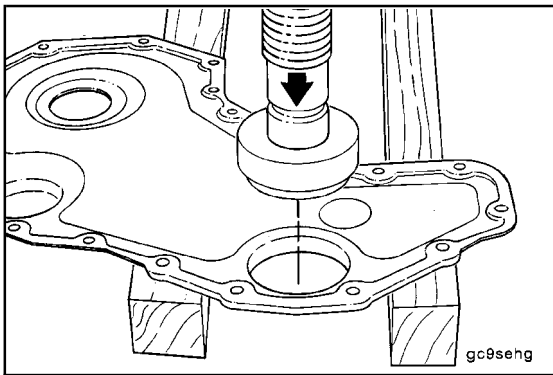

**NOTE:** Properly support the front cover lubricating oil seal flange to prevent damage to the lubricating oil seal and front cover.

Press the lubricating oil seal into the front cover from the **backside** of the cover toward the frontside of the cover.

Press the lubricating oil seal until the service tool bottoms against the front cover.

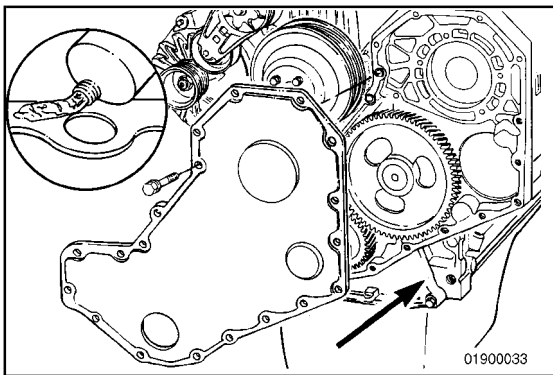

Apply a thin bead of Three-Bond™ to the **cover** side of the front cover gasket **only**.



**NOTE:** Do **not** remove the plastic seal pilot tool from the lubricating oil seal at this time. Use the plastic seal pilot tool to guide the seal on the crankshaft.

Install the gasket and front gear cover on the engine. Refer to Procedure 001-031.

**NOTE:** The front gear cover capscrews **must** be tightened within 15 minutes of applying the sealant on the gasket.

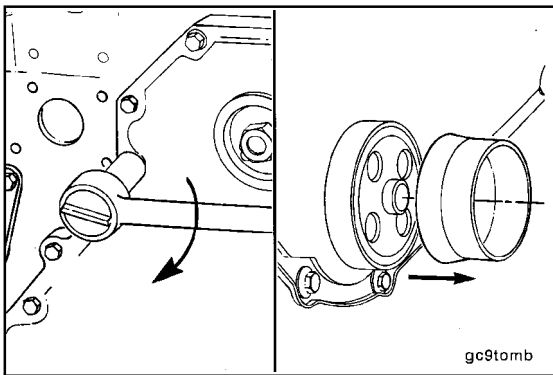

Tighten the front gear cover mounting capscrews.

Remove the plastic pilot tool from the crankshaft.



**Torque Value:** 24 N•m [18 ft-lb]



**B3.9 and B5.9 Series Engines**  
**Section 1 - Cylinder Block - Group 01**

Install the vibration damper. Do **not** tighten the capscrews to the correct torque value at this time. Refer to Procedure 001-051 or 001-052.

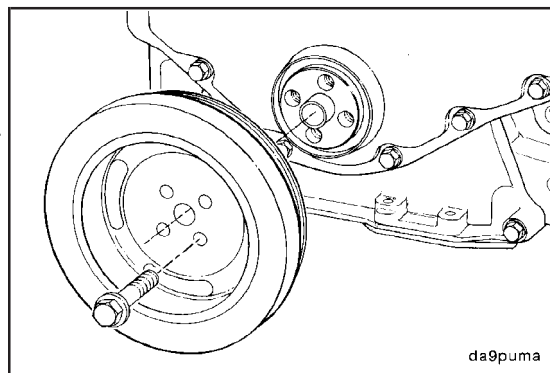

da9puma

Install the drive belt. Refer to Procedure 008-002.

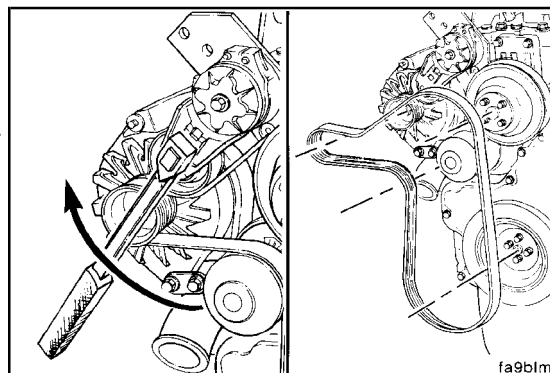

fa9blma

Tighten the vibration damper capscrews.

**Torque Value:** 125 N•m [92 ft-lb]

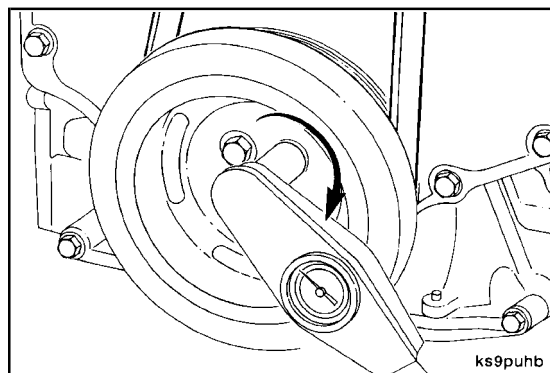

ks9puhb

**Crankshaft Seal, Rear (001-024)**

**Preparatory (001-024-000)**

- Remove the transmission. Refer to OEM service manual.
- Remove the flywheel. Refer to Procedure 016-005.

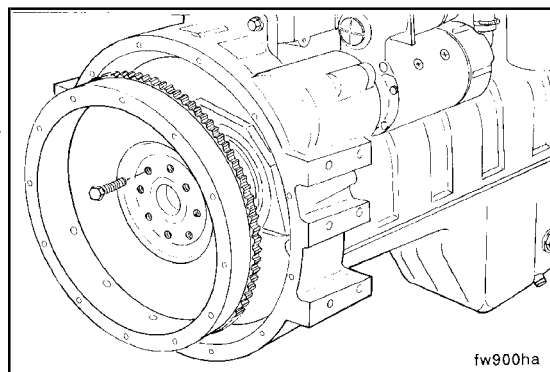

fw900ha

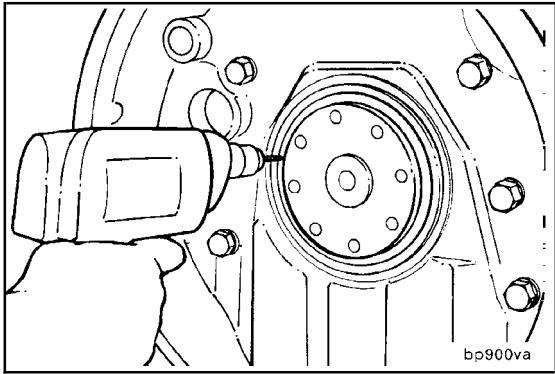

**Remove (001-024-002)**

1/8 Drill

Drill two holes 180 degrees apart into the seal carrier.

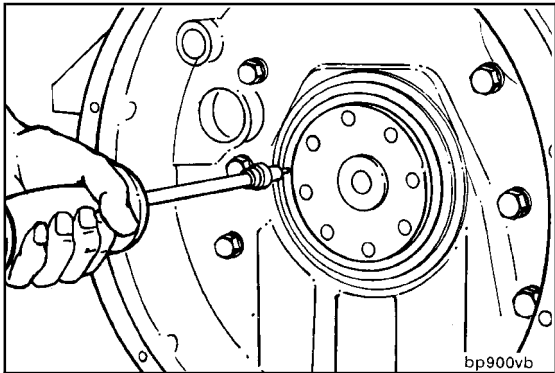

**No. 10 Sheet Metal Screw, Slide Hammer Dent Puller**

Remove the rear seal.

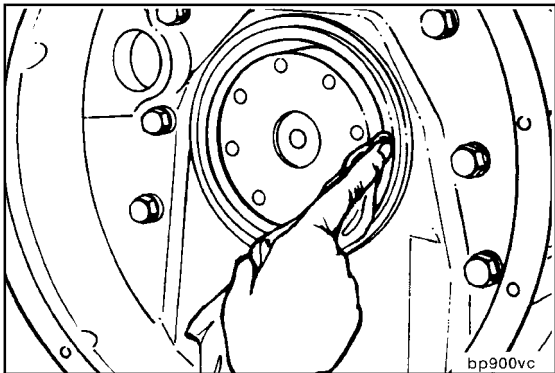

**Clean (001-024-006)**

**▲ CAUTION ▲**

The seal lip and the sealing surface on the crankshaft must be free from all oil residue to reduce the possibility of seal leaks.

Clean and dry the rear crankshaft sealing surface.

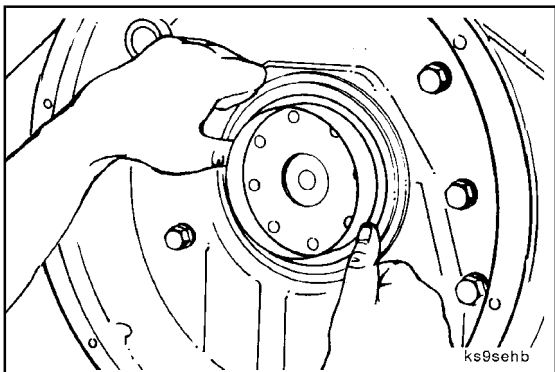

**Install (001-024-026)**

Install the seal pilot, provided in the replacement kit, onto the crankshaft. Push the seal onto the pilot and crankshaft.

Remove the seal pilot.



**NOTE:** For installation, the lubricating oil seal requires a mild soap on the outside diameter of the seal case.

**Wear Sleeve Installation Tool, Part No. 3824078**

Use the alignment tool to install the seal to the correct depth in the housing. Use a hammer to drive the seal into the housing until the alignment tool stops against the housing.

Hit the tool at 12-, 3-, 6-, and 9-o'clock positions to drive the seal evenly and to prevent bending the seal carrier.

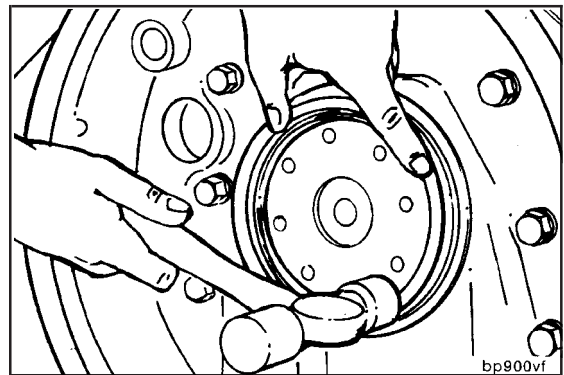

**19 mm**

Install the flywheel. Tighten the capscrews in sequence as shown in the illustration.

Refer to Procedure 016-005.

**Torque Value:** 137 N•m [101 ft-lb]

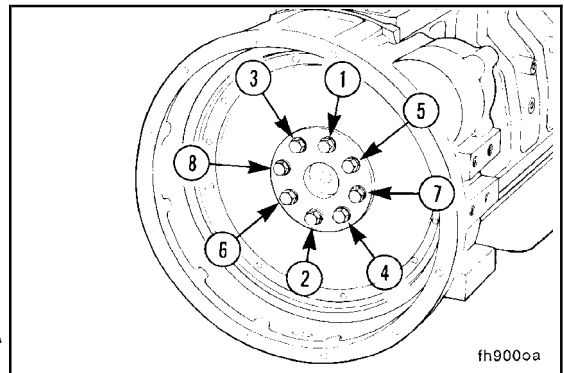

Install the clutch, transmission, and starter. Refer to OEM service manual.

Operate the engine, and check for leaks.

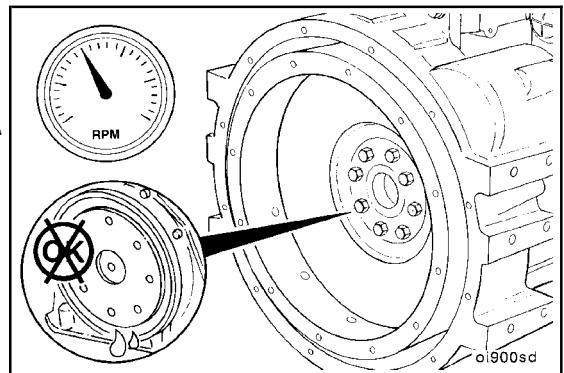

**Crankshaft Wear Sleeve, Front (001-025)**

**Preparatory (001-025-000)**

Remove the drive belt. Refer to Procedure 008-002.



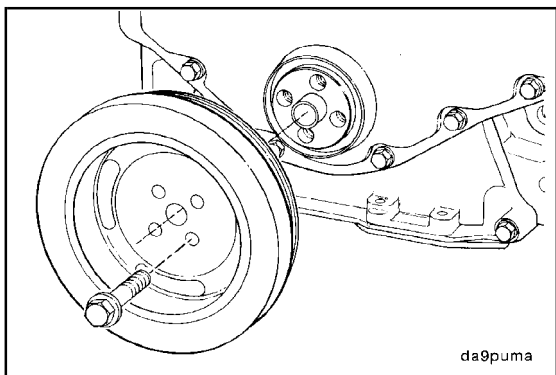

Remove the vibration damper. Refer to Procedure 001-052.

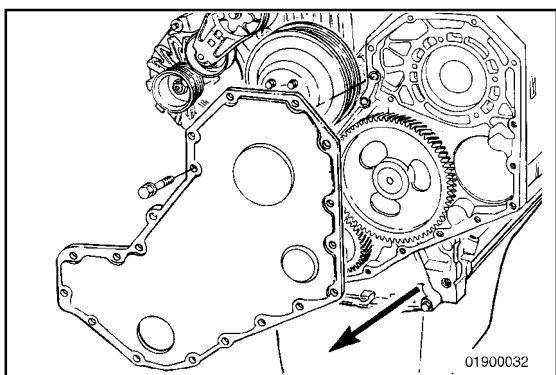

**Remove (001-025-002)**

Remove the gear cover. Refer to Procedure 001-031.

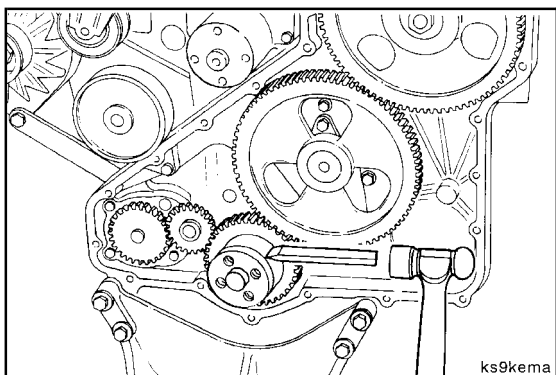

**CAUTION**

Do not nick or gouge the crankshaft with the chisel. If the crankshaft is damaged, it must be replaced.

**NOTE:** Use a hammer and chisel that is **only** as wide as the wear sleeve.

Make one or two chisel marks across the wear sleeve. This will expand the wear sleeve, allowing the sleeve to be removed.

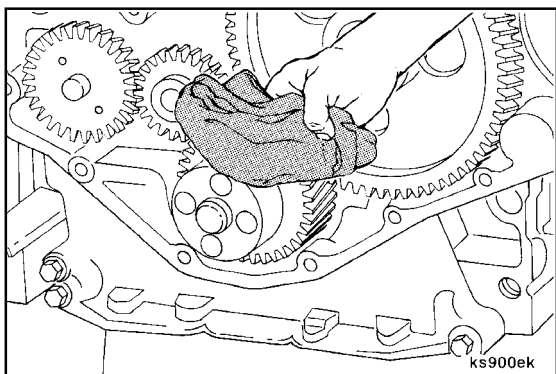

**Clean (001-025-006)**

Use a crocus cloth to remove any rust or other deposits from the crankshaft flange.

Use a clean cloth to clean the crankshaft flange.

**Inspect for Reuse (001-025-007)**

Inspect the seal contact area of the crankshaft for a wear groove. If the seal has worn a groove deep enough to be felt with a sharp object or fingernail, it will be necessary to install a wear sleeve to prevent an oil leak.

The oil seal used with the wear sleeve has a larger inside diameter than the standard seal. The two seals are **not** interchangeable. Refer to the appropriate B Series parts catalog for the correct part number.

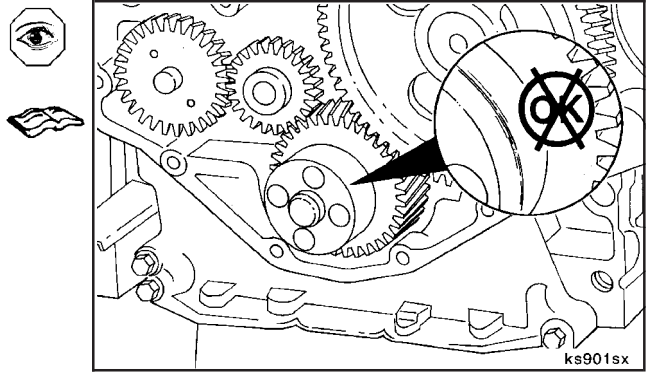

**Install (001-025-026)**

**Crankshaft Front Wear Sleeve Installation Tool, Part No. 3824500**

Use the driver to install the wear sleeve to the correct position on the crankshaft. The kit consists of the following:

Ref. No.	Description	Qty.
1	Driver	1
2	Spacer	2
3	Capscrew M14 x 1.5 x 60 mm	2
4	Hairpin Cotter	2

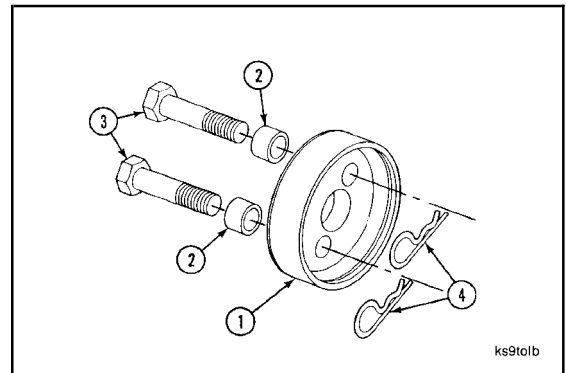

Apply a thin coat of clean lubricating engine oil to the inside diameter and capscrew threads.

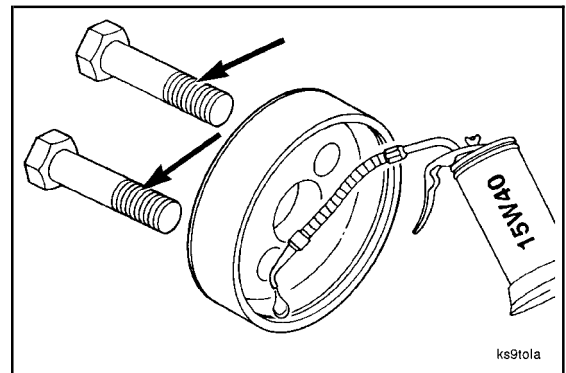

Apply a thin coat of clean lubricating engine oil to the crankshaft flange.

Position the chamfered end of the wear sleeve onto the end of the crankshaft.

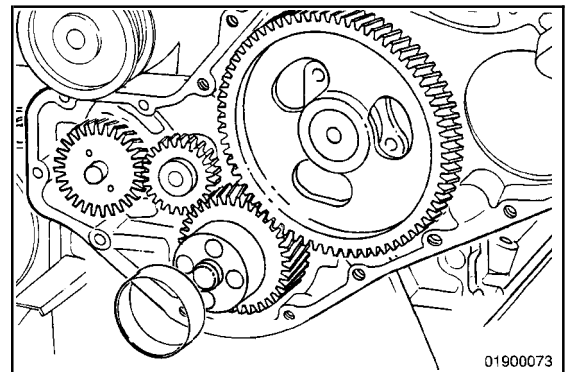

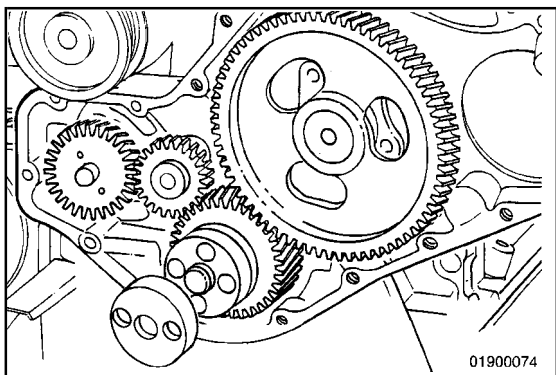

Position the counterbore end of the driver onto the wear sleeve.

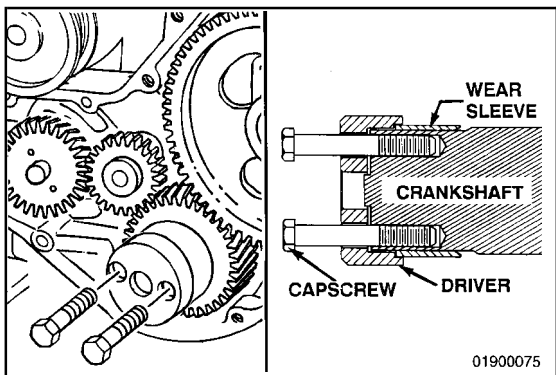

Install two cap screws (without spacers or hairpin cotts) through the driver and into the crankshaft cap screw holes.

Align the wear sleeve and driver perpendicular to the crankshaft.

Tighten the cap screws "finger-tight."

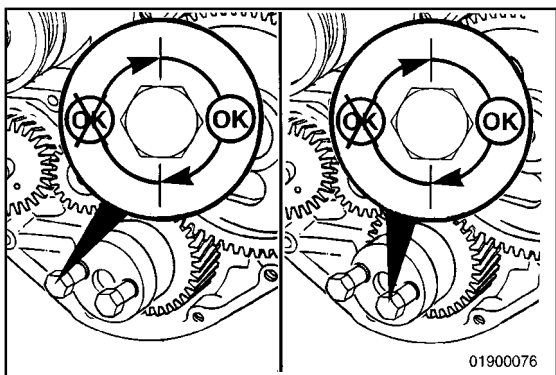

**CAUTION**

To prevent damage to the wear sleeve, do not exceed one-half revolution of each cap screw.

Alternately tighten the cap screws one-half turn until the sleeve is installed to a depth of approximately 16 mm [0.625 in].

**Torque Value:** 20 N•m [15 ft-lb]

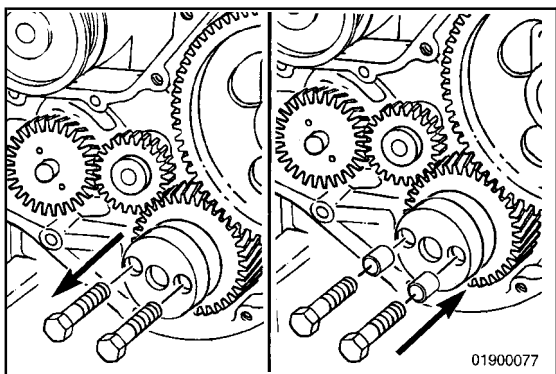

Remove the two cap screws.

Install the spacer on each cap screw.



Install the two cap screws.

Continue to tighten the capscrews alternately until the bottom of the driver contacts the end of the crankshaft.

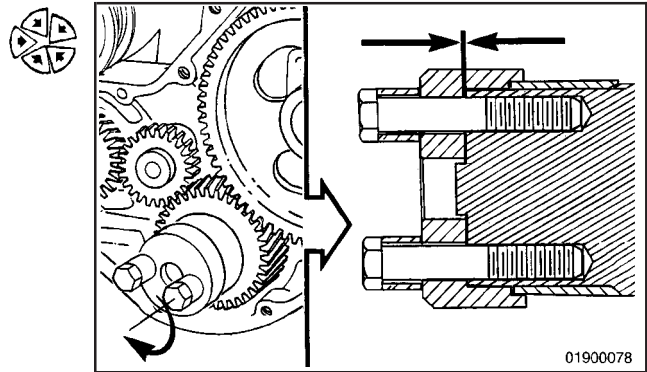

Remove the driver. Use the hairpin cotters to secure the capscrews and spacers to the tool during storage.

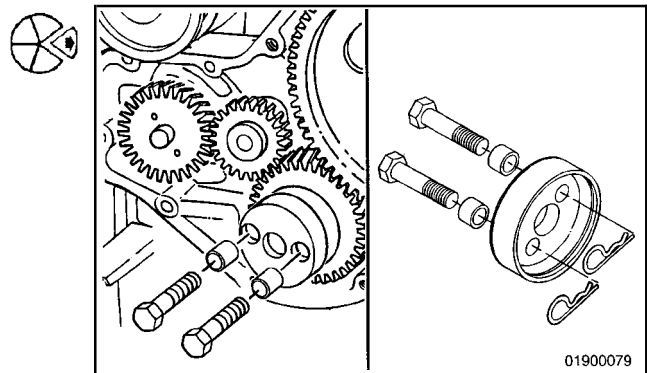

Install a new seal into the gear cover. Refer to Procedure 001-023.

Install the front gear cover. Refer to Procedure 001-031.

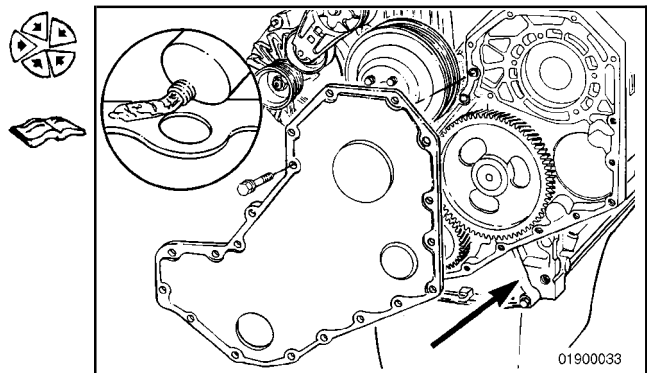

**Cylinder Block (001-026)**

**General Information**

Diagnosis of cylinder block cooling and lubrication malfunctions has been discussed in those respective sections. The potential problems with the cylinder, the camshaft bore, and the crankshaft main journals have also been discussed in this section.

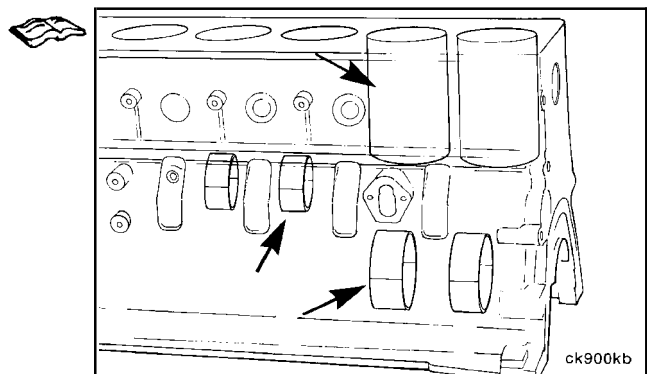

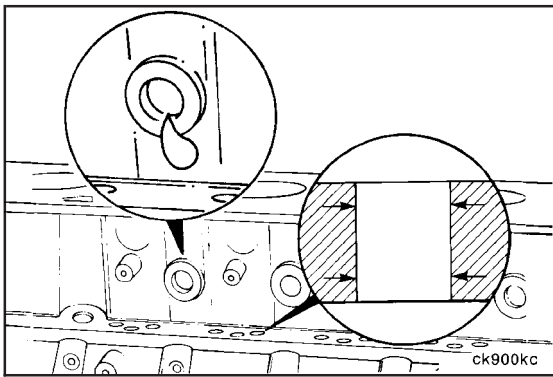

Malfunctions of the cylinder block, such as leaks, tappet bore wear, etc. require a visual or dimensional inspection to isolate the problem.

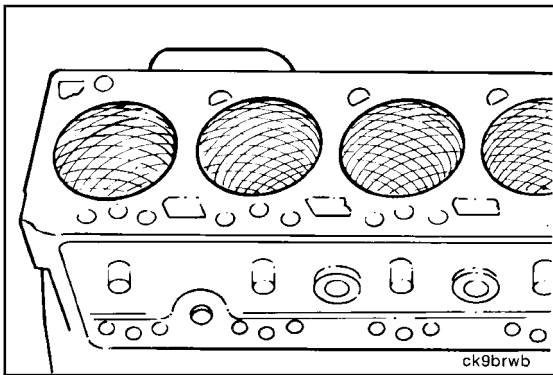

The cylinder bores are machined directly into the cylinder block during production. The size and condition of the cylinder bore is critical to engine performance and life. During repair, be sure to inspect the cylinder bore carefully. It will also be necessary to deglaze the cylinder walls before reassembly. A 30-degree crosshatch pattern is needed to seat the new piston rings.

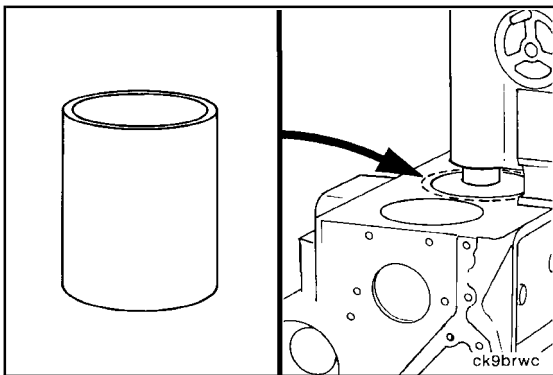

The cylinder bores can be rebored in a machine shop and fitted with an oversize service piston. The cylinder bore can also be bored to accept a service liner and standard pistons. Refer to the B Series Alternative Repair Manual, Bulletin No. 3810234, for rebore procedures.

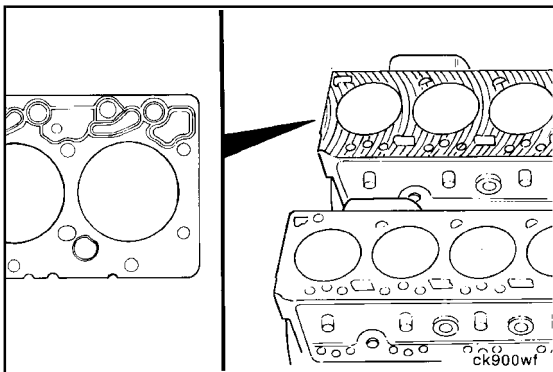

**NOTE:** The head surface of the block is also critical to sealing the cylinder bores. Inspect the surface carefully during repair before assembly. The cylinder head deck can be resurfaced in a machine shop and a thicker surface cylinder head gasket installed to keep the piston-to-head clearance the same.



After machining, the cylinder block is stamped at the upper rear right corner surface of the cylinder block as follows:

Machining	Mark
A - Standard	None
B - 0.25 mm [0.010 in] machined for first oversize gasket	X
C - 0.25 mm [0.010 in] machined 0.50 mm [0.020 in] total for second oversize gasket	XX

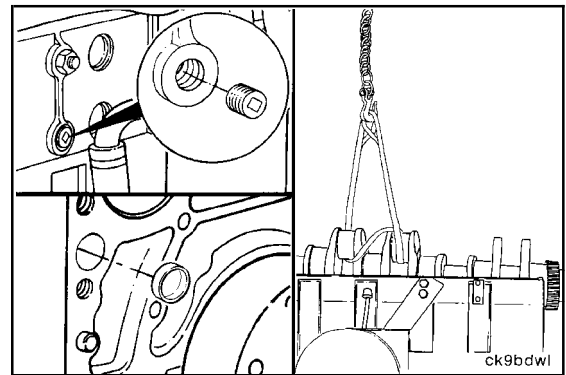

**Preparatory (001-026-000)**



**WARNING**

Coolant is toxic. If not reused, dispose of in accordance with local environmental regulations.

**Cylinder Bore Deglaze**

Drain the coolant. Refer to Procedure 008-018.

Remove the cylinder head. Refer to Procedure 002-004.

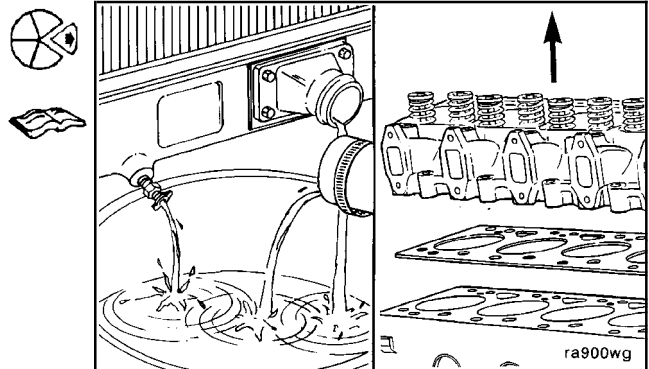

**WARNING**

To avoid personal injury, avoid direct contact of hot oil with your skin.

Drain the lubricating oil. Refer to Procedure 007-025.

Remove the lubricating oil pan and gasket. Refer to Procedure 007-025.

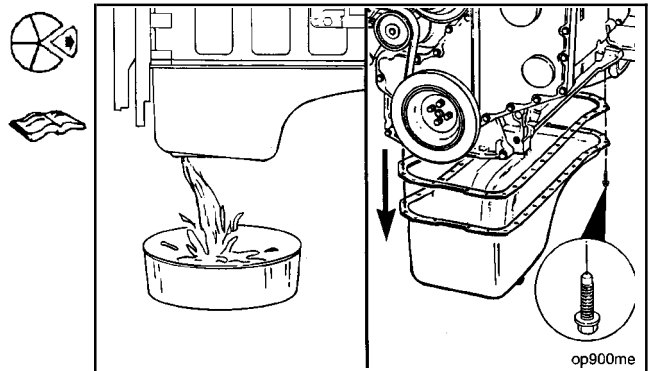

**Disassemble (001-026-003)**

Remove the piston and connecting rod assemblies. Refer to Procedure 001-054.

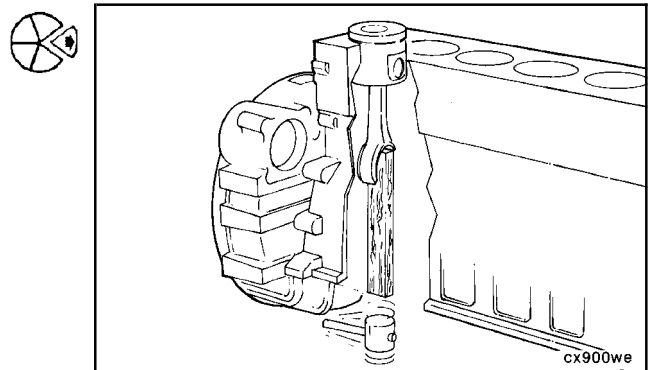

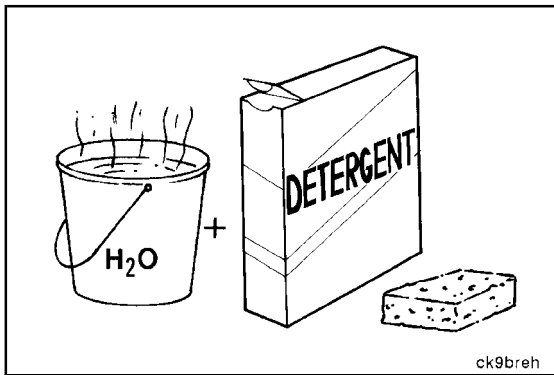

**Clean (001-026-006)**

Use a strong solution of hot water and laundry detergent to clean the cylinder bores.

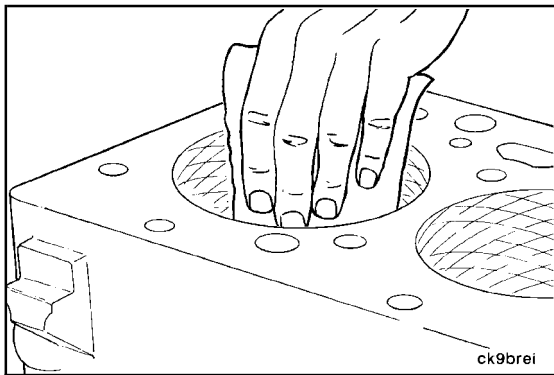

**▲ WARNING ▲**

Wear appropriate eye and face protection when using compressed air. Flying debris and dirt can cause bodily injury.

**▲ CAUTION ▲**

Clean the cylinder bores immediately after deglazing, or premature wear of the bores and rings can result.

Rinse the cylinder bores until the detergent is removed.

Dry the cylinder block with compressed air.

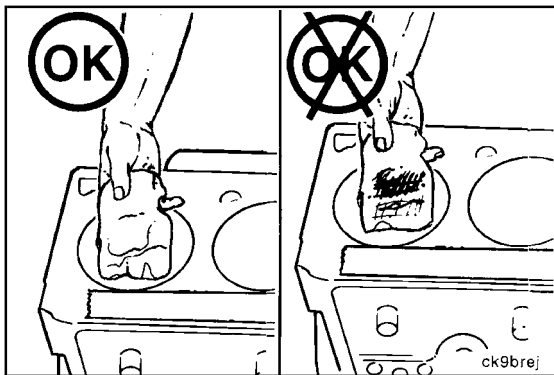

**▲ WARNING ▲**

When using solvents, acids, or alkaline materials for cleaning, follow the manufacturer's recommendations for use. Wear goggles and protective clothing to avoid personal injury.



**▲ WARNING ▲**

Wear appropriate eye and face protection when using compressed air. Flying debris and dirt can cause bodily injury.

**NOTE:** Be sure to remove the tape covering the tappet and lubricating oil holes after the cleaning process is complete.

Check the cylinder bore cleanliness by wiping with a white, lint-free, lightly oiled cloth. If grit residue is still present, repeat the cleaning process until all residue is removed.

Wash the cylinder bores with solvent.

Dry the cylinder block with compressed air.

**B3.9 and B5.9 Series Engines**  
**Section 1 - Cylinder Block - Group 01**

**NOTE:** Be sure to remove the covering from the piston cooling nozzles.

Remove the protective tape and cloth, and clean the crankshaft journals.

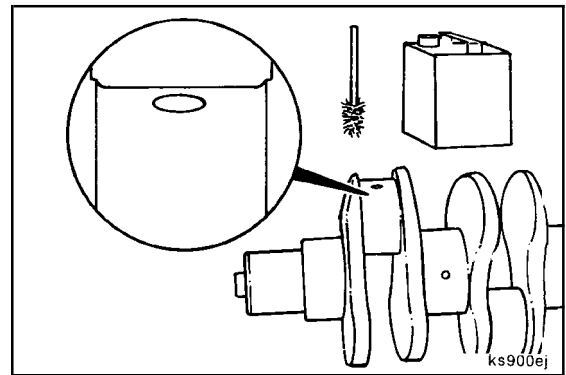

**⚠ WARNING ⚠**

When using solvents, acids, or alkaline materials for cleaning, follow the manufacturer's recommendations for use. Wear goggles and protective clothing to avoid personal injury.

Use a solvent and a brush to clean any residue that possibly has splashed on the camshaft.

Inspect the camshaft lobes and tappet faces for signs of wear or damage. Refer to Procedure 001-008.

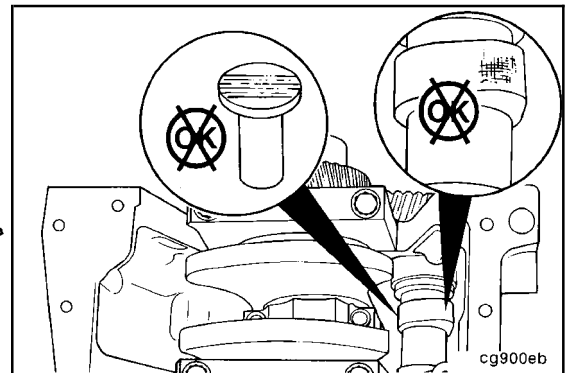

**Inspect for Reuse (001-026-007)**

Measure the cylinder bore diameter at 25.4 mm [1 in.] and 170.7 mm [6.7 in.] from the top of the cylinder block.

Bore I.D. Max - 102.116 mm [4.0203 in.]

Bore out of round - 0.035 mm [0.0014 in.]

Bore taper - 0.076 mm [0.003 in.]

**NOTE:** Do **not** proceed with in-chassis overhaul if the cylinder bores are worn beyond specifications.

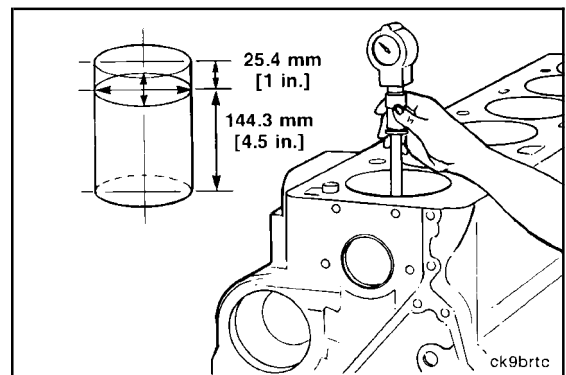

**Assemble (001-026-025)**

Install the piston and connecting rod assemblies. Refer to Procedure 001-054.

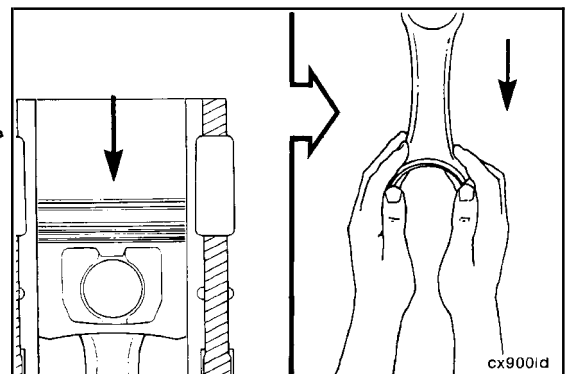

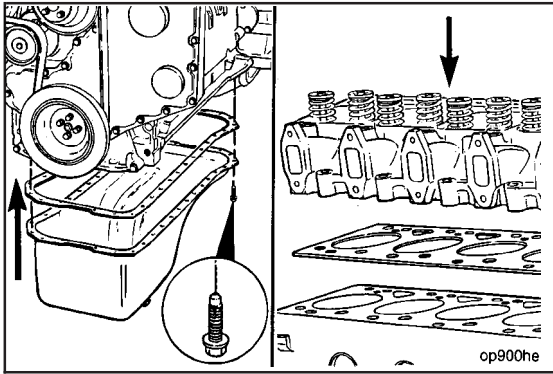

Install the lubricating oil pan and gasket. Refer to Procedure 007-025.

**Torque Value:** 24 N•m [18 ft-lb]



Install the cylinder head. Refer to Procedure 002-004.

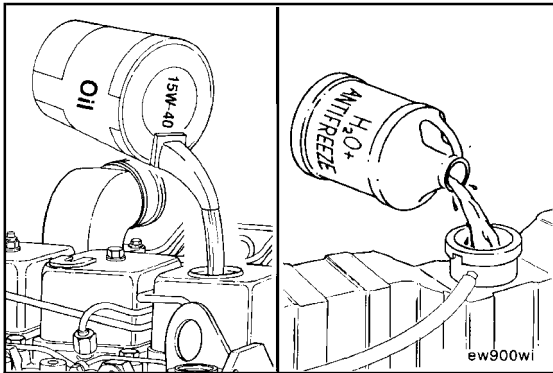

Fill the lubricating oil pan. Refer to the Operation and Maintenance Manual, B Series Engines, Bulletin No. 3810205 for the correct lubricating oil specification.

Fill the engine with coolant. Refer to Procedure 008-018.

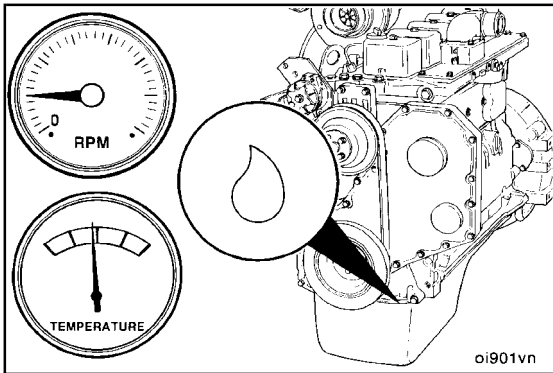

Operate the engine to normal operating temperature, and check for leaks.

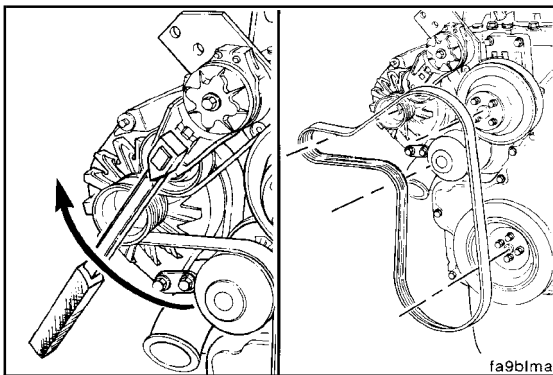

### Gear Cover, Front (001-031)

#### Remove (001-031-002)



Remove the drive belt. Refer to Procedure 008-002.

**NOTE:** Removal is easier if the vibration damper is loosened before removing the belt.

15 mm

Remove the vibration damper. Refer to Procedure 001-052.

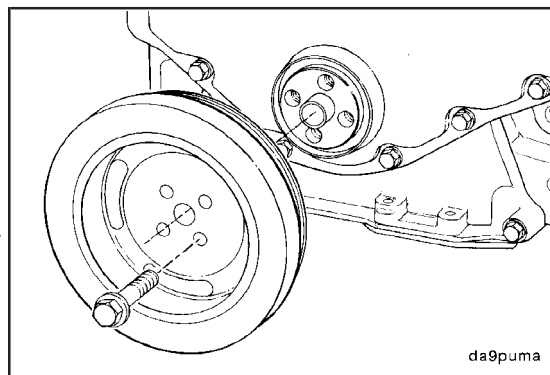

10 mm

If required, remove the fan hub pulley. Refer to Procedure 008-036.

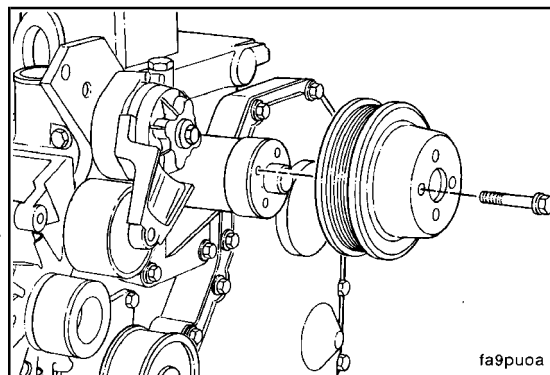

10 mm

Remove the front gear cover.

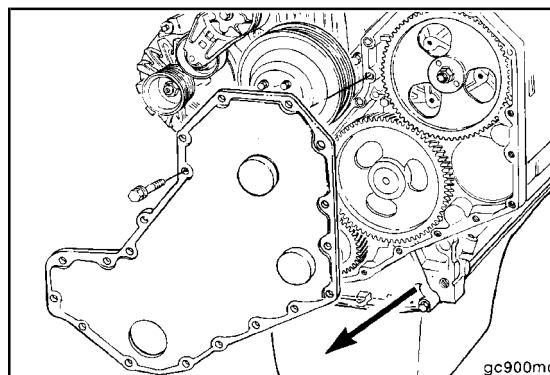

**Clean (001-031-006)**

Clean the gear cover and gear housing gasket surface.

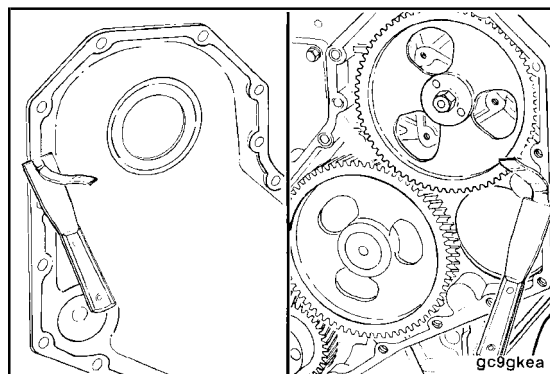

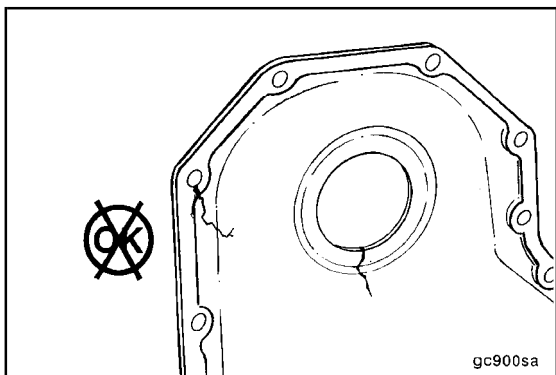

**Inspect for Reuse (001-031-007)**

Inspect the gear cover for cracks or damage.

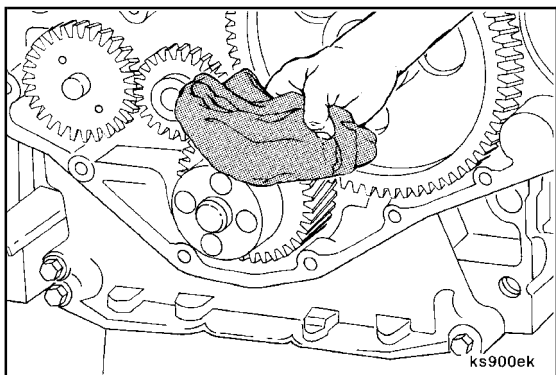

**CAUTION**

The crankshaft must be clean, dry, and oil-free before installing the gear cover. Failure to clean the sealing surface properly can result in an oil leak.

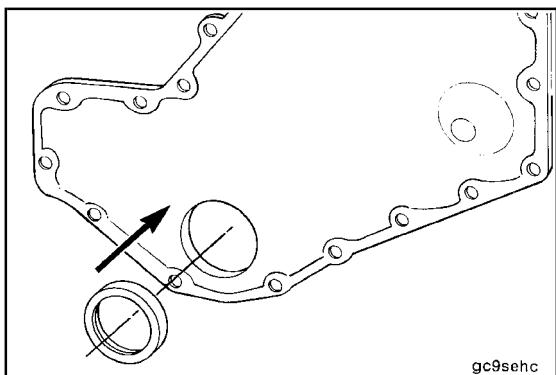

**Install (001-031-026)**

Install a new seal in the gear cover. Refer to Procedure 001-023.

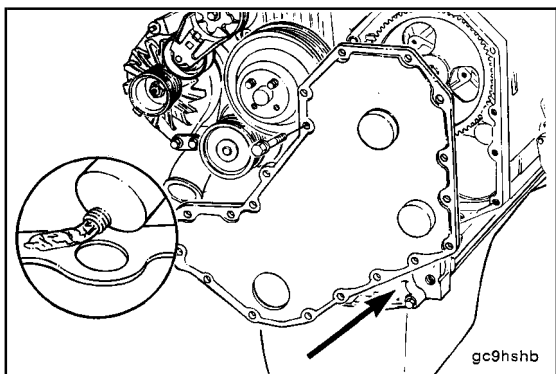

Apply a thin bead of Three-Bond™ to the cover side of the front cover gasket **only**.

**NOTE:** Do **not** remove the plastic seal pilot tool from the lubricating oil seal at this time. Use the plastic seal pilot tool to guide the seal on the crankshaft.

Install the gasket and front cover on the engine.

**10 mm**

Tighten front cover capscrews.

Remove the plastic pilot tool from the crankshaft.

**Torque Value:** 24 N•m [18 ft-lb]

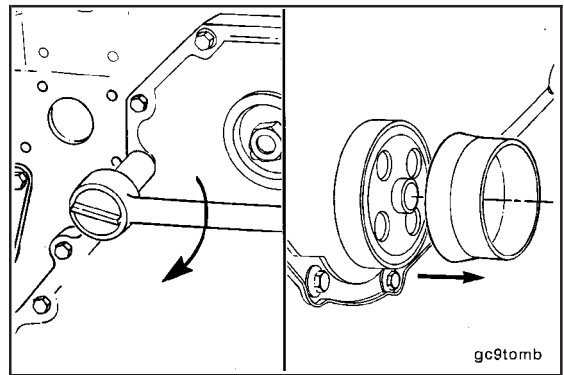

**15 mm**

Install the vibration damper. Refer to Procedure 001-052. Do **not** tighten the capscrews to the correct torque specification at this time.

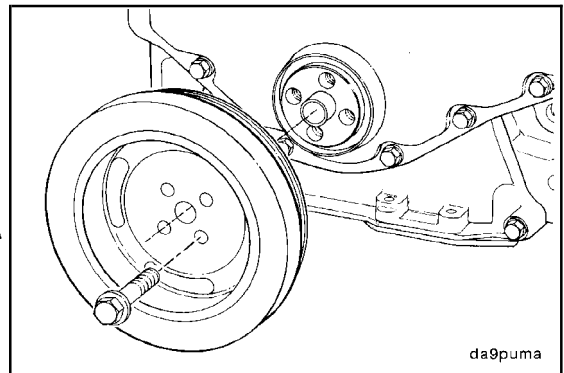

**3/8-Inch Square Drive**

Install the drive belt. Refer to Procedure 008-002.

**Service Tip:** If difficulty is experienced installing the drive belt (the belt seems too short), position the belt over the grooved pulleys first; then, while holding the tensioner up, slide the belt over the water pump pulley.

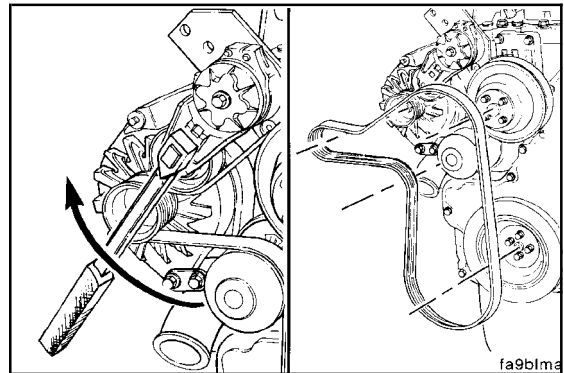

Tighten vibration damper capscrews.

**Torque Value:** 125 N•m [92 ft-lb]

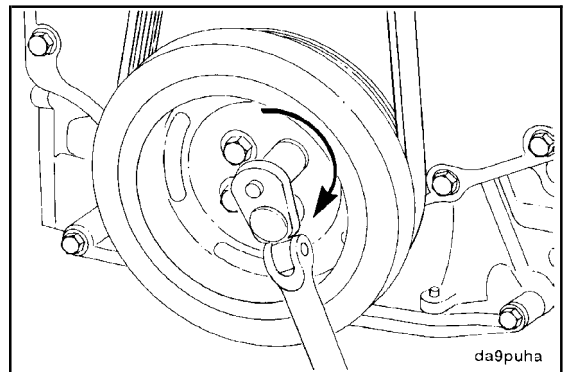

## Gear Housing, Front (001-033)

### General Information



Troubleshooting the front gear housing and gear train consists of checking for leaks at the gaskets (front cover, timing pin assembly and fuel injection pump) and the front crankshaft lubricating oil seal, inspecting the gears, and measuring backlash when required.

Replace the front crankshaft oil seal. Refer to Procedure 001-023.

Gear noise emitted from the cover can indicate worn gear teeth.

**NOTE:** Excessive backlash can affect engine timing and engine performance.

The gear train consists of the crankshaft gear (1), lubricating oil pump gear (2), idler gear (3), the camshaft gear (4), the fuel injection pump gear (5), and the accessory drive gear (6), if used.

The gear housing provides a support for the fuel injection pump, the timing pin, and the accessory drive gear, if used.

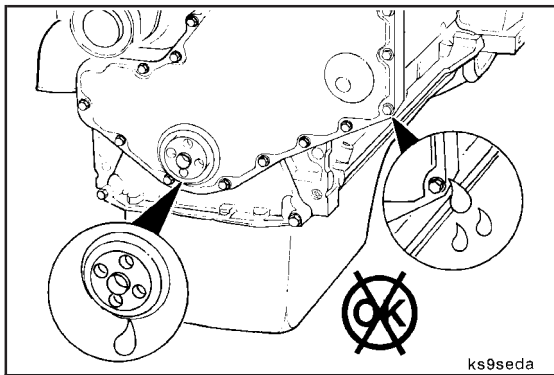

ks9seda

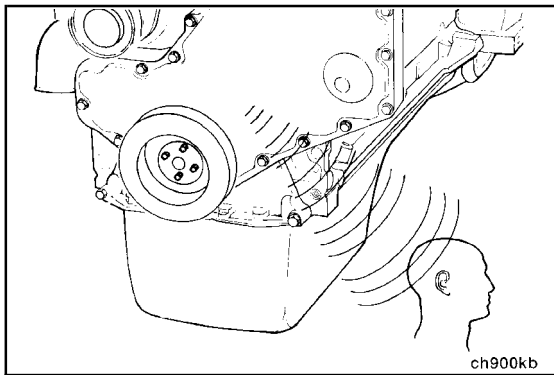

ch900kb

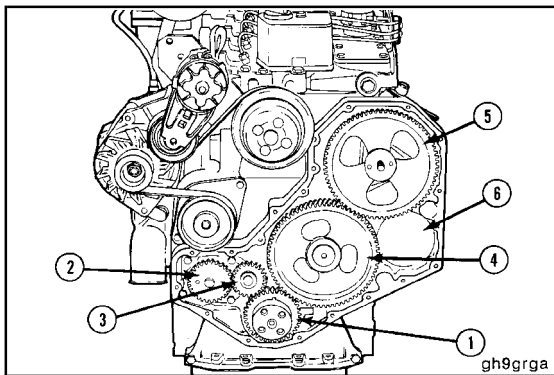

gh9grga

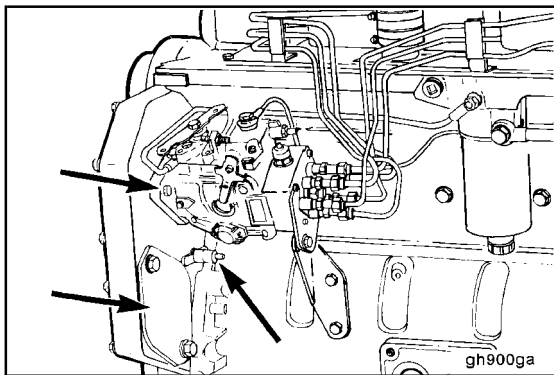

gh900ga



**B3.9 and B5.9 Series Engines**  
**Section 1 - Cylinder Block - Group 01**

Replacement of the gear housing or the timing pin assembly necessitates a realignment of the pin assembly on the housing to correspond to TDC for cylinder No. 1. Refer to Procedure 001-013.

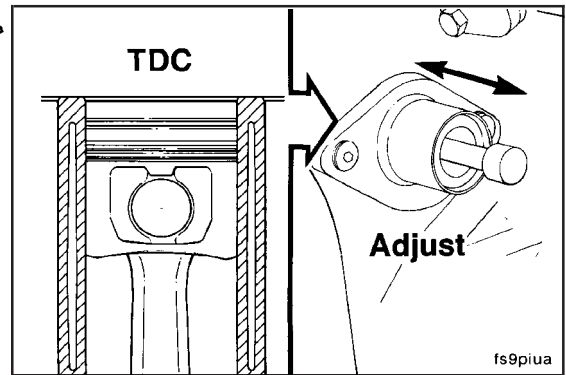

**Preparatory (001-033-000)**

- Remove the rocker lever covers. Refer to Procedure 003-011.
- Remove the rocker levers. Refer to Procedure 003-008.
- Remove the push tubes. Refer to Procedure 004-014.
- Remove the vibration damper. Refer to Procedure 001-052.
- Remove the camshaft. Refer to Procedure 001-008.
- Remove the fuel pump. Refer to Procedure 005-012 or 005-014.

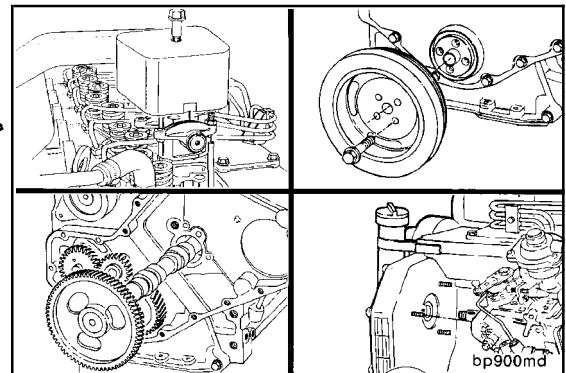

**Remove (001-033-002)**

**10 mm**

Remove the six front oil pan capscrews.

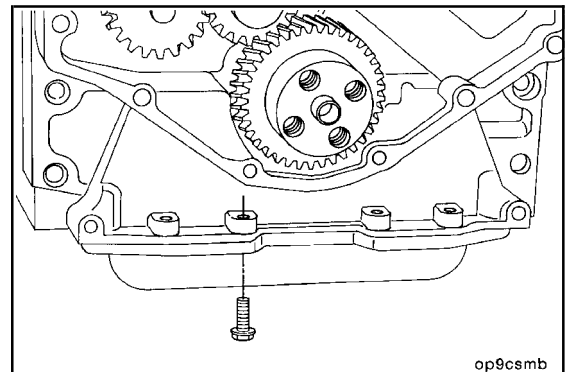

**10 mm**

Remove the gear housing capscrews.

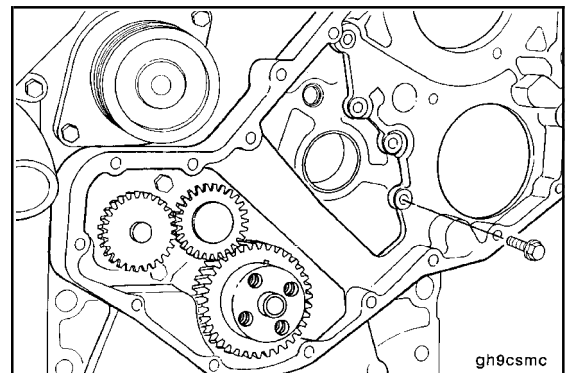

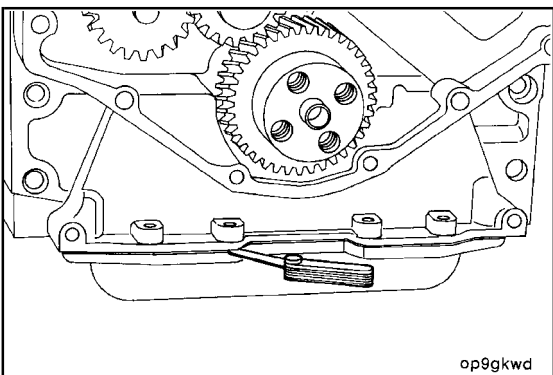

Using a feeler gauge, attempt to separate the lubricating oil pan gasket from the gear housing.

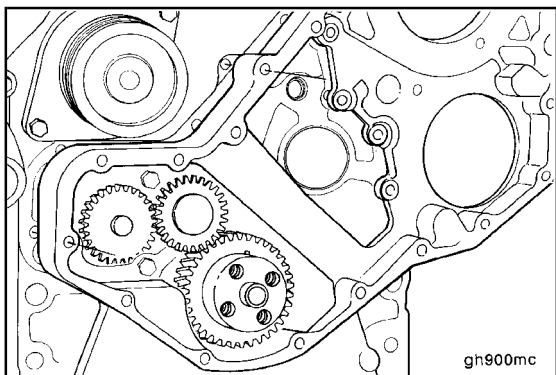

**Plastic Hammer**

Remove the gear housing.

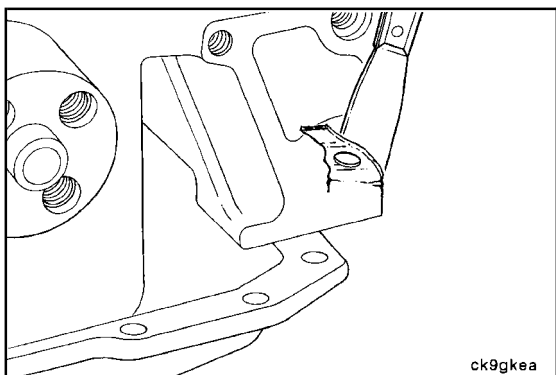

**Clean (001-033-006)**

Clean the gasket material from the cylinder block.

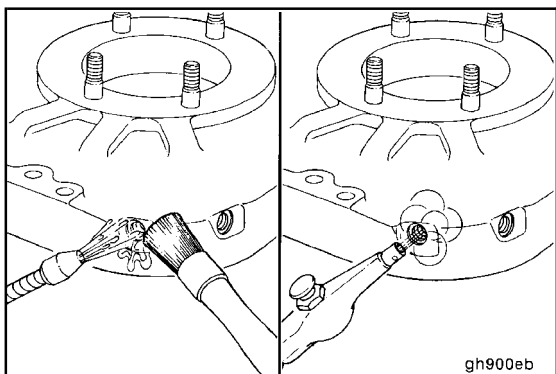

**▲ WARNING ▲**

When using solvents, acids, or alkaline materials for cleaning, follow the manufacturer's recommendations for use. Wear goggles and protective clothing to avoid personal injury.

**▲ WARNING ▲**

Wear appropriate eye and face protection when using compressed air. Flying debris and dirt can cause bodily injury.

Use solvent and a nylon brush to clean the oil drillings.

Dry the front gear housing with compressed air.

**Inspect for Reuse (001-033-007)**

Inspect the front gear housing for cracks or damaged sealing surfaces.

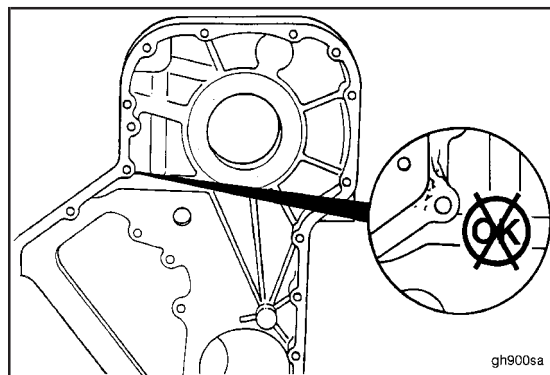

**NOTE:** If the front gear housing is cracked at the accessory drive hole, double check the accessory/air compressor installation practices.

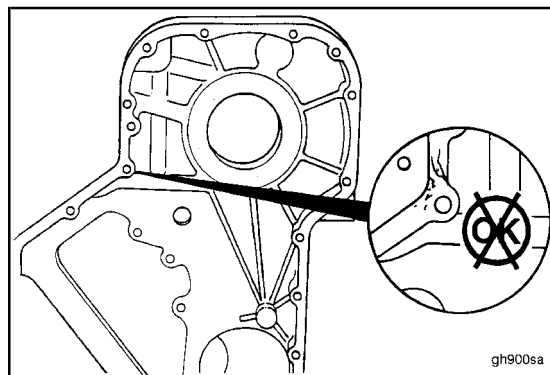

Inspect the timing pin housing and pin for damage.

**NOTE:** Do **not** remove the timing pin assembly unless it is damaged or leaking, or the gear housing is being replaced.

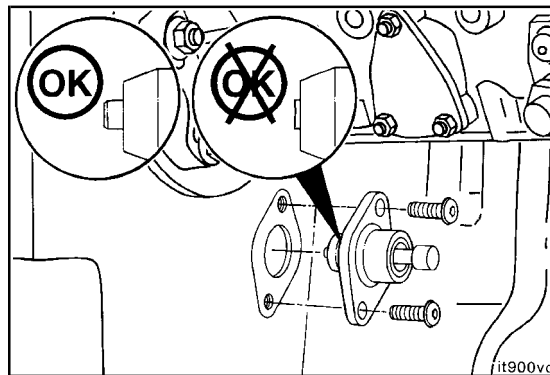

If the fuel injection pump studs are damaged or being installed in a new housing, coat the threads with Loctite 242. Use two nuts locked together to remove and install the studs.

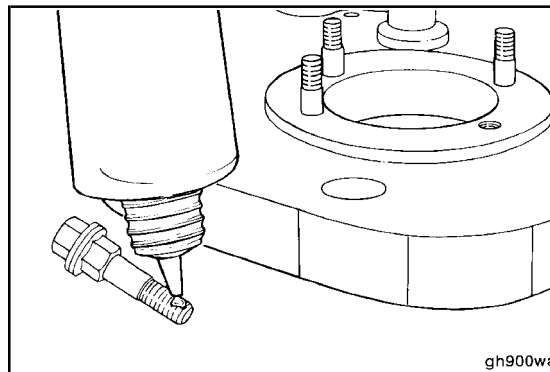

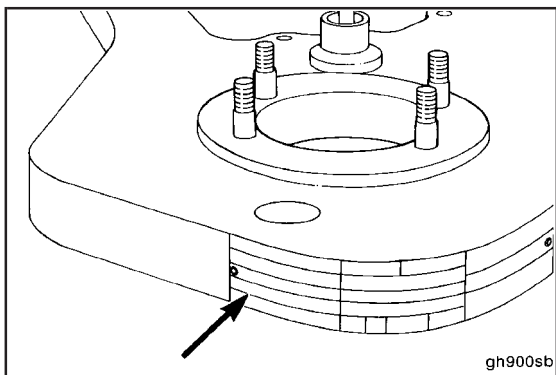

If the gear housing is being replaced, remove the engine dataplate and install it on the new gear housing; refer to Procedure 001-057.

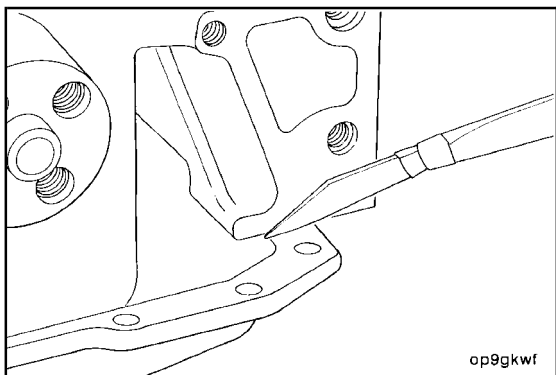

**Install (001-033-026)**

**Pan Gasket - Repair**

If the pan gasket is torn, it can be repaired. Cut the torn gasket off even with the front of the cylinder block.

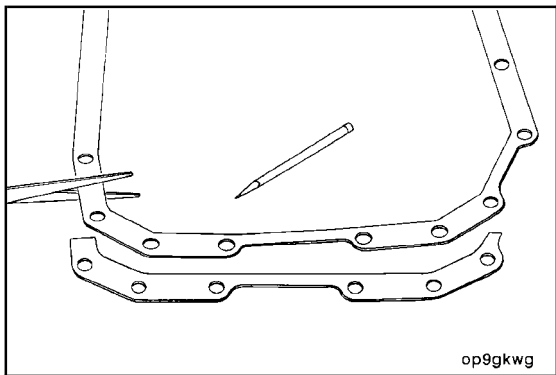

Using the old gasket as a pattern, cut the front section of a new gasket to the same size.

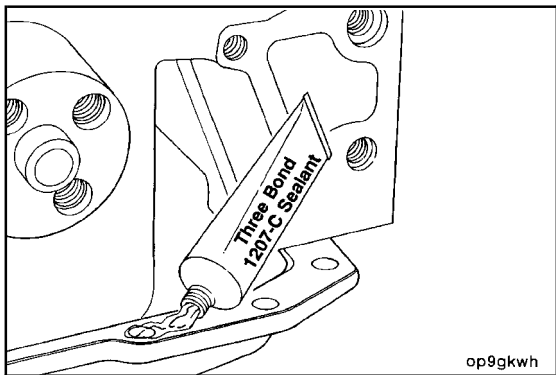

**Three-Bond™ Sealant, Part No. 3823494**

Clean the sealing surfaces and coat the new gasket on both sides with Three-Bond™ 1207-C sealant, Part No. 3823494, or equivalent.



**B3.9 and B5.9 Series Engines**  
**Section 1 - Cylinder Block - Group 01**

Use common thread or a very fine wire to hold the new gasket splice in position as illustrated.

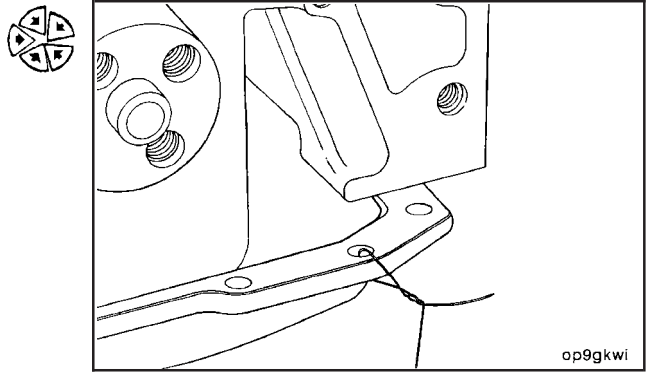

Mark and trim 1.59 mm [1/16 in] off the new gear housing gasket.

**NOTE:** When properly trimmed, the gear housing gasket should be even with the lubricating oil pan gasket when installed.

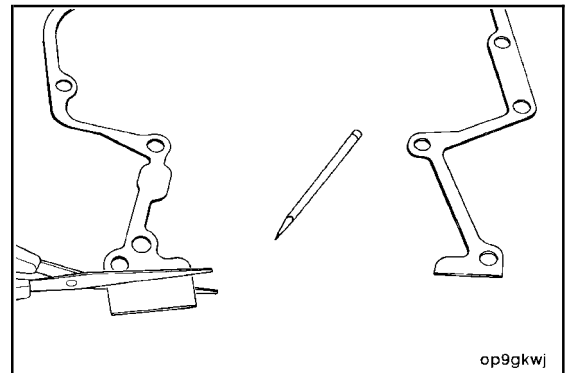

Position the gasket on the alignment dowels.

Use guide pins (M8 x 1.25 x 50) to assist in aligning the gasket and gear housing. Be sure to remove the guide pins after alignment.

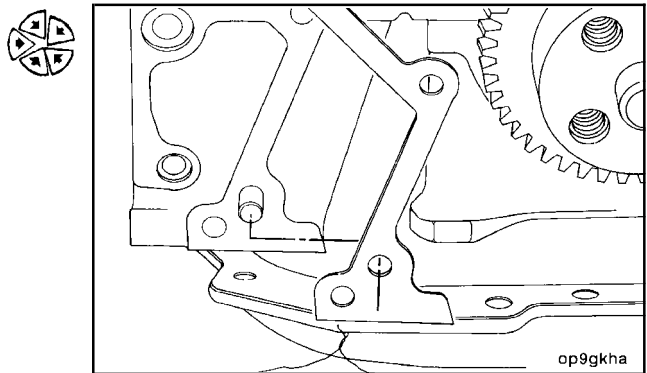

**10 mm**

Carefully install the gear housing, making sure both gaskets are in place.

**Torque Value:** 24 N•m [18 ft-lb]

If a new housing, or other than the original housing is installed, the timing pin assembly **must** be accurately located. Refer to Procedure 001-049.

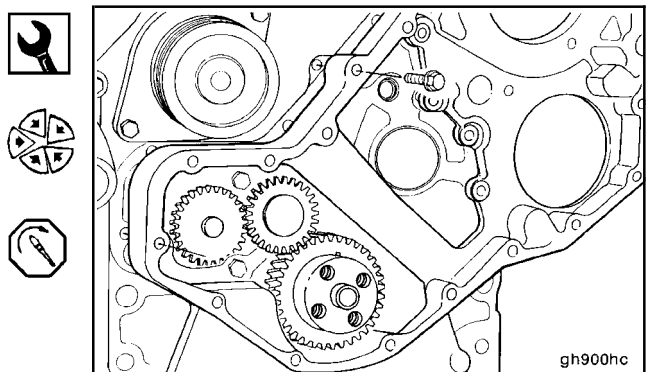

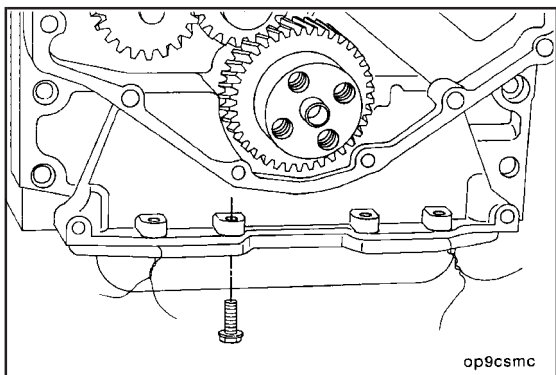

Start the oil pan cap screws in the holes **not** being used to tie the gasket in place.

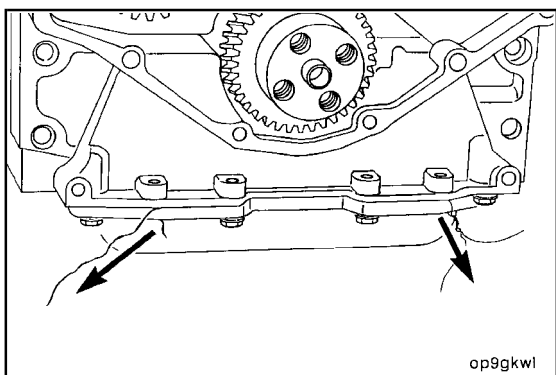

Remove the thread or wire holding the gasket in place.

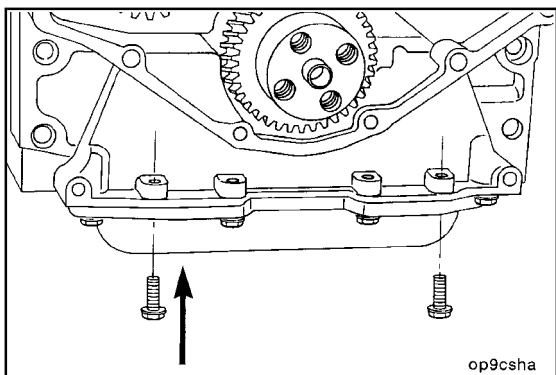

10 mm

Install the remaining two cap screws and tighten.

**Torque Value:** 24 N•m [18 ft-lb]

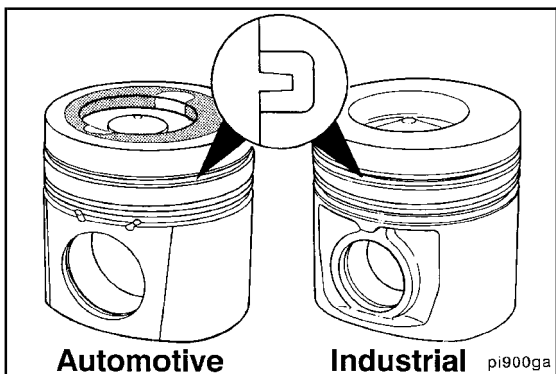

## Piston (001-043)

### General Information

Piston features include high-swirl combustion bowl cast-aluminum body and three-ring grooves. The piston for turbocharged, turbocharged/aftercooled engines includes a ni-resist insert with a keystone profile for the top piston ring. **Always** check the part number to be sure the correct configuration is used during piston replacement.

In addition to the ni-resist insert, automotive turbocharged engines also feature pistons with a hard-anodized combustion surface.

The piston ring sets are also different. While both sets consist of three rings, the top ring of the turbocharged/aftercooled set has a keystone profile that operates in a groove machined into the aluminum piston. The naturally aspirated top ring is square cut and operates in a groove machined into the aluminum piston.

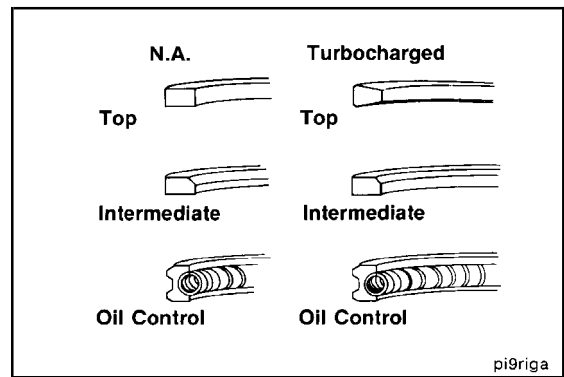

The 1994 automotive pistons utilize different top ring locations. The 160-hp to 175-hp ratings use 8-mm crown to ring land pistons and 190 hp to 210 hp use 10 mm. The 1994 industrial pistons continue with the 14 mm ring position.

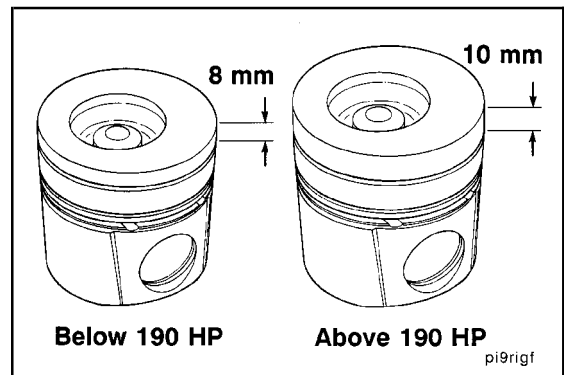

Overheating of the engine from a loss of coolant will cause the cylinder to overheat, resulting in seizure of the piston. Loss of piston cooling lubricating oil can also lead to piston seizure.

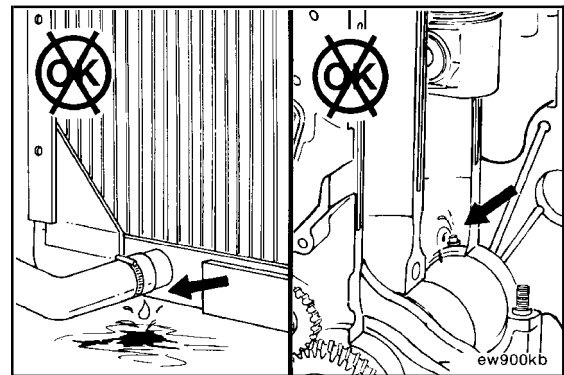

**Preparatory (001-043-000)**



**WARNING**

**Coolant is toxic. If not reused, dispose of in accordance with local environmental regulations.**

- Drain the coolant. Refer to Procedure 008-018.
- Remove the cylinder head. Refer to Procedure 002-004.

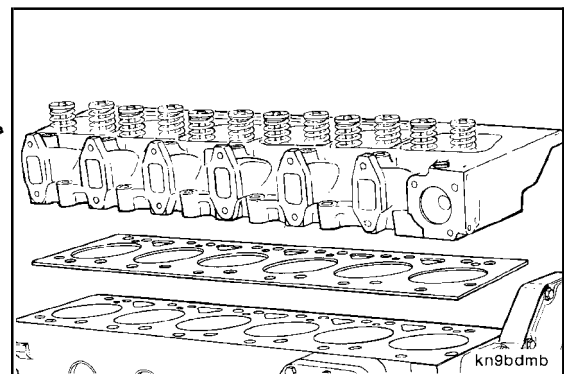

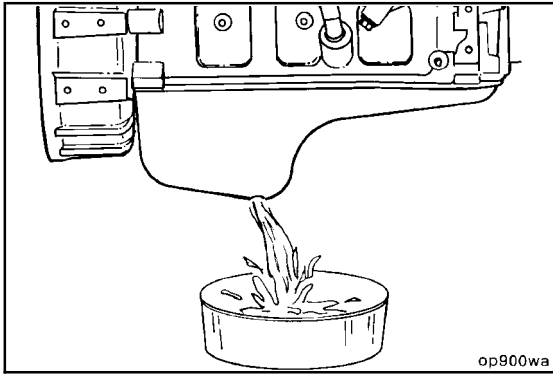

**▲ WARNING ▲**

Some state and federal agencies have determined that used engine oil can be carcinogenic and cause reproductive toxicity. Avoid inhalation of vapors, ingestion, and prolonged contact with used engine oil.



**▲ WARNING ▲**

To avoid personal injury, avoid direct contact of hot oil with your skin.



17 mm

Drain the lubricating oil. Refer to Procedure 007-025.

After lubricating oil is drained, install the drain plug and a new sealing washer.

**Torque Value:** 80 N•m [59 ft-lb]

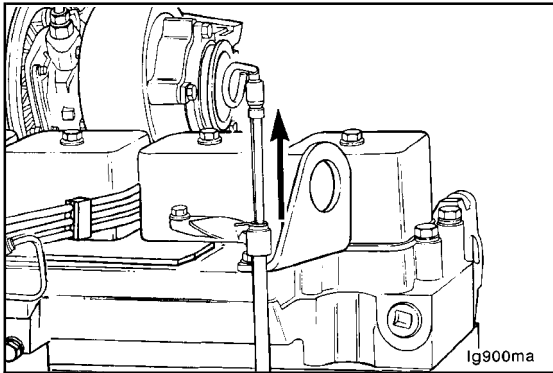

Remove the dipstick bayonet.

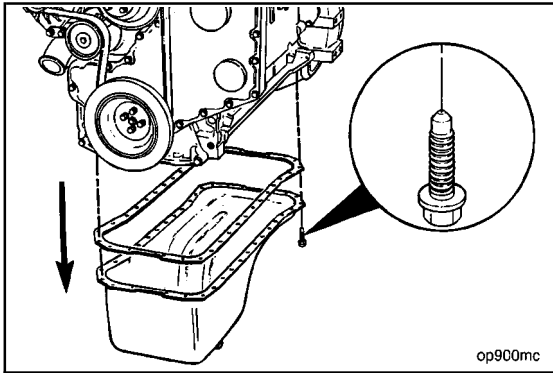

10 mm

Remove the lubricating oil pan and gasket. Refer to Procedure 007-025.

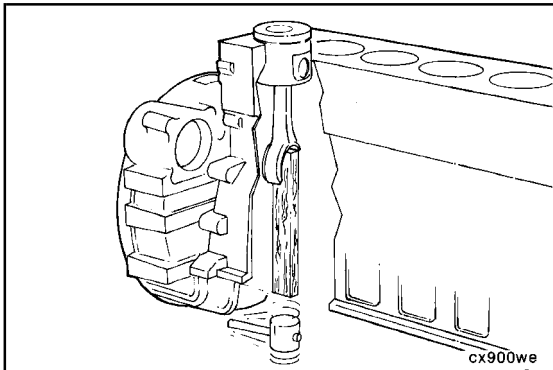

**Remove (001-043-002)**

**NOTE:** The piston and connecting rods **must** be removed as an assembly.



Remove and disassemble the piston and connecting rod assembly. Refer to Procedure 001-054.



**Clean (001-043-006)**

**⚠ CAUTION ⚠**

Do not use the bead-blast method to clean the piston. The piston can be damaged by blast material embedded in the aluminum.

Soak the pistons in cold parts cleaner.

Soaking the pistons overnight will usually loosen the carbon deposits.

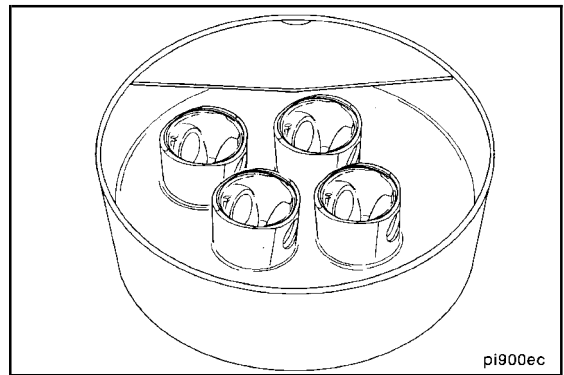

pi900ec

**⚠ CAUTION ⚠**

Do not clean the pistons and rods in an acid tank.

Wash the pistons and rods in a hot soapy, solution.

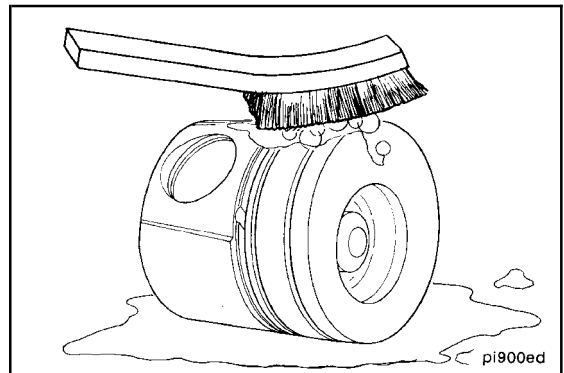

pi900ed

**⚠ CAUTION ⚠**

Do not use a ring groove cleaner and be sure not to scratch the ring sealing surface in the piston groove.

Clean the remaining deposits from the ring grooves with the square end of a broken ring.

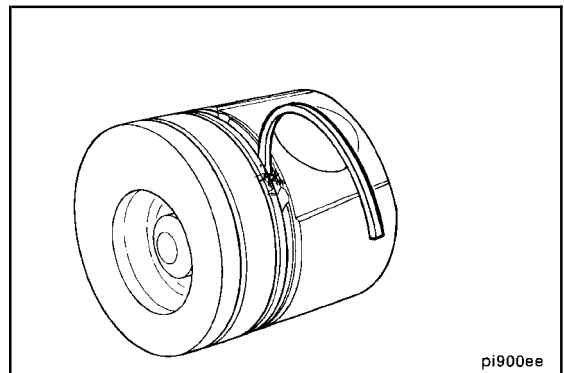

pi900ee

**⚠ WARNING ⚠**

When using solvents, acids, or alkaline materials for cleaning, follow the manufacturer's recommendations for use. Wear goggles and protective clothing to avoid personal injury.

**⚠ WARNING ⚠**

Wear appropriate eye and face protection when using compressed air. Flying debris and dirt can cause bodily injury.

Wash the pistons again in a detergent solution or solvent.

Dry with compressed air.

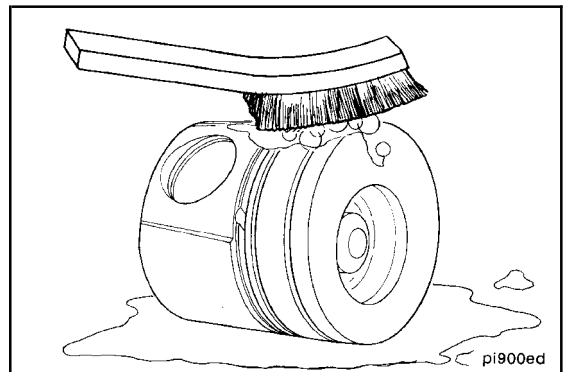

pi900ed

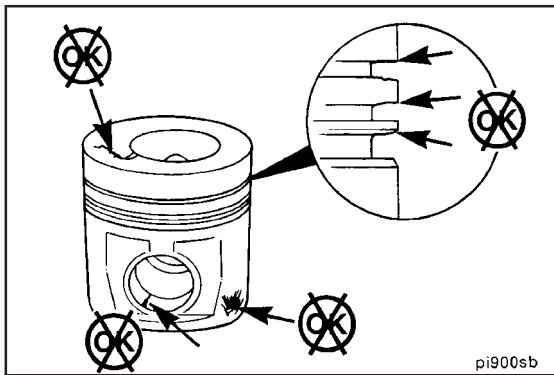

**Inspect for Reuse (001-043-007)**

Inspect the piston for damage and excessive wear. Check the top, ring grooves, skirt, and pin bore.

**NOTE:** If severe piston damage has occurred, check the turbocharger and other exhaust components for damage from debris.

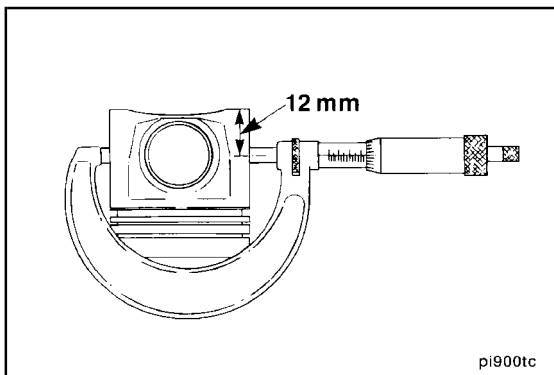

Measure the piston skirt diameter as illustrated.

Piston Skirt Diameter		
mm		in
101.823	MIN	4.0088
101.887	MAX	4.0107

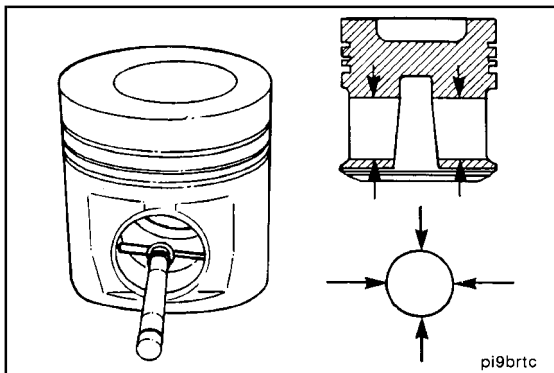

Measure the pin bore.

Piston Pin Bore Diameter		
mm		in
40.006	MIN	1.5750
40.025	MAX	1.5758

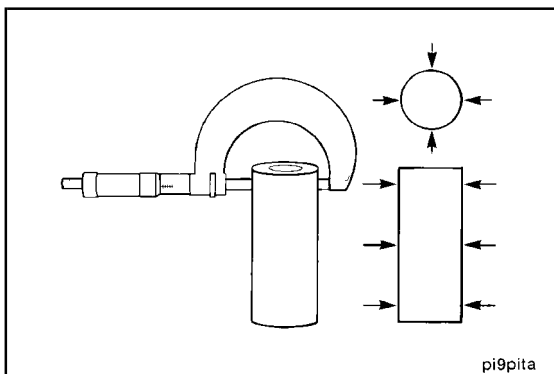

**Piston Pin - Inspection**

Inspect the piston pin for nicks, gouges, and excessive wear.



Measure the pin diameter.

Pin Diameter		
mm		in
39.990	MIN	1.5744
40.003	MAX	1.5749

**Test (001-043-012)**

**Compression Gauge and Adapter**

It is very time consuming and expensive to begin removing internal engine components to diagnose failures. A compression gauge can be used as an aid to detect failures.

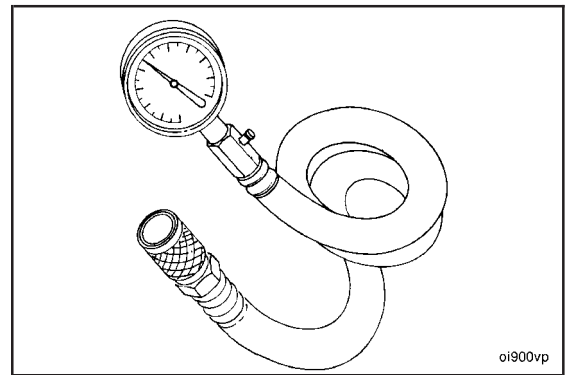

**Compression Check**

If the air and fuel system are functioning correctly, perform a compression check to determine whether the problem is:

- Piston ring sealing
- Valve sealing
- Cylinder head gasket sealing or a crack in the cylinder head.

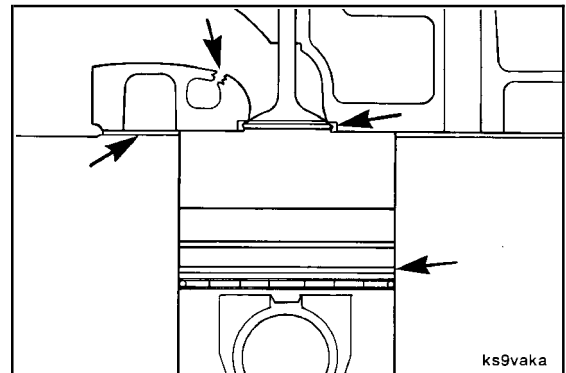

**NOTE:** Due to variables such as; starter and battery conditions that affect engine cranking speed, it is difficult to establish an absolute value for compression pressure; however, the following values can be used as guidelines:

- New engine (cranking speed @ 250 rpm) 2413 kPa [350 psi]
- Used engine (cranking speed @ 250 rpm) 2068 kPa [300 psi].

It is recommended that the compression pressure be checked and compared on all cylinders. All cylinders should be within 690 kPa [100 psi] of each other.

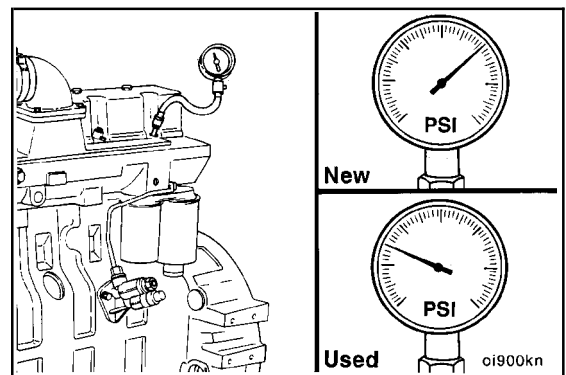

**Piston Ring Sealing**

If the compression is low but can be increased significantly by squirting lubricating oil into the cylinder, the cause of low compression is inadequate sealing between the piston rings and the cylinder walls.

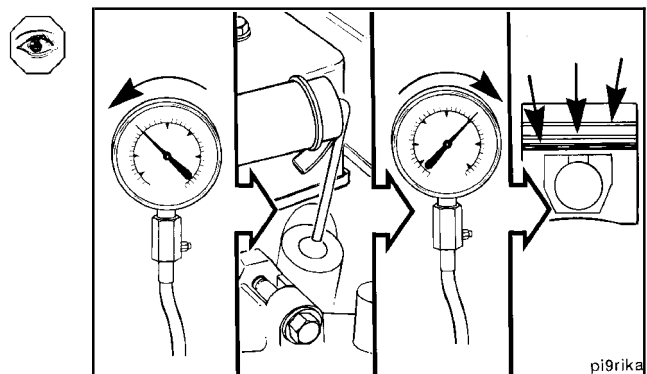

**Valve Sealing**

If the compression is low on one or more nonadjacent cylinders and the pressure can **not** be increased by oiling the rings, poor valve sealing is to be suspected.

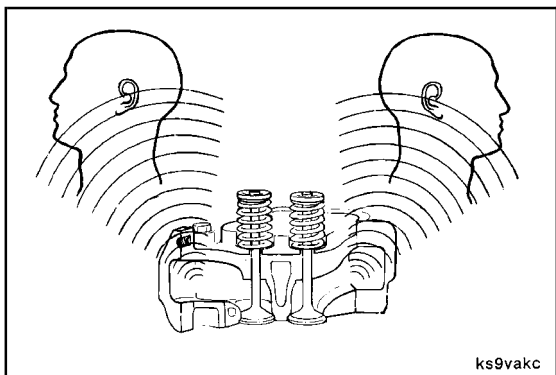
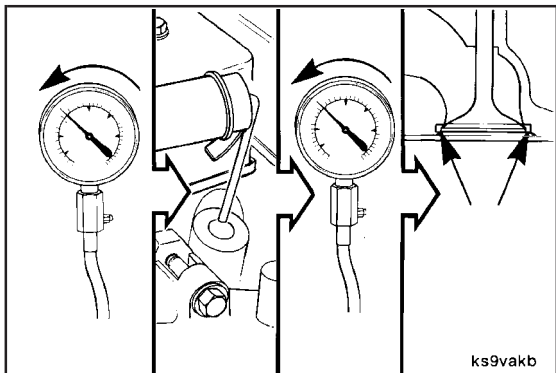

Valve leakage is often audible from the intake and/or exhaust manifold.

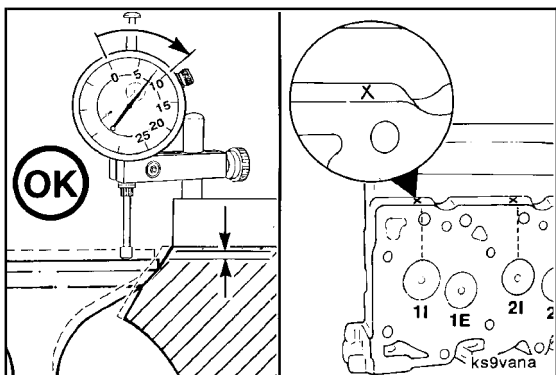

The parent valve seats can be reground to a depth of 0.254 mm [0.010 in]. Reground seats are identified with a mark on the cylinder head. Service valve seats **must** be installed in previously ground valve seats.

**Head Gasket Sealing**

If the compression was found low on adjacent cylinders and the pressure can **not** be increased by oiling the rings, the head gasket is probably leaking between the cylinders.

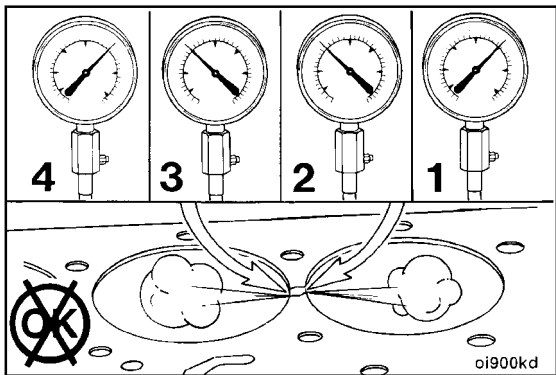

Low compression on a single cylinder can be caused by an external leak or a leak to a coolant passage.

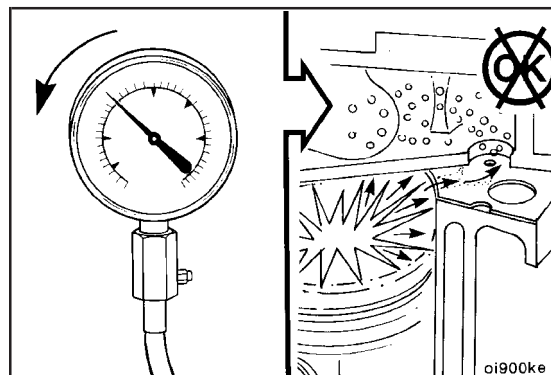

A compression leak to the coolant will normally be detected by loss of coolant as the coolant is blown from the cooling system.

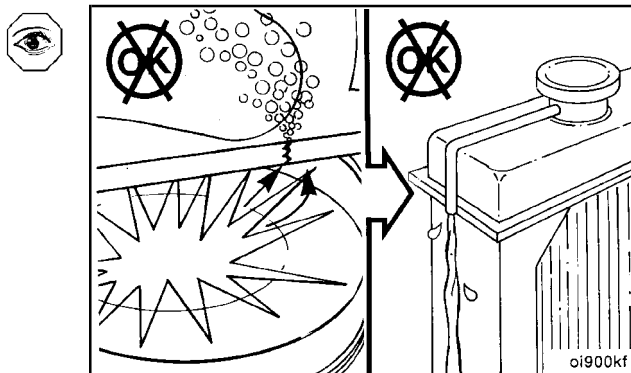

External cylinder head gasket leaks can be detected visually. Liquid soap can be used to locate external leaks.

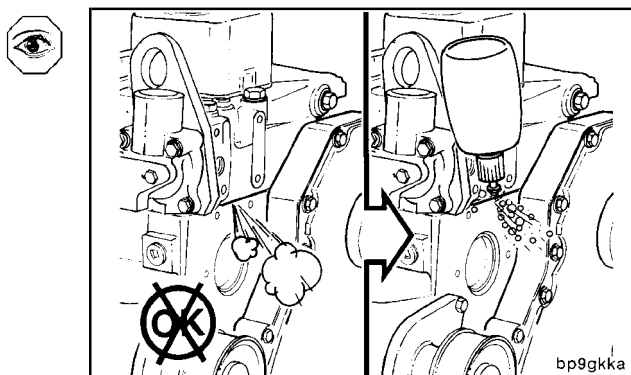

The cause of piston ring wear can range from wear over a long period of service to a dust-out in a short period because of poor maintenance of the air intake system.

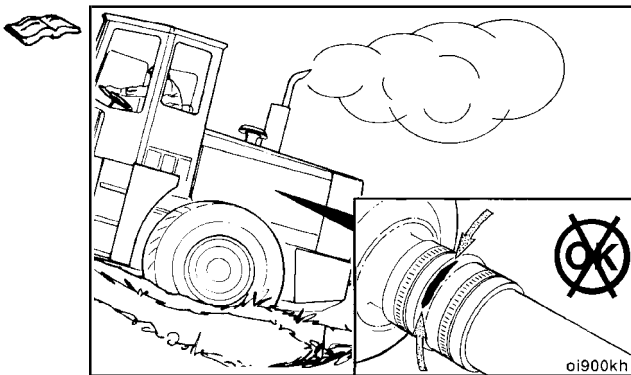

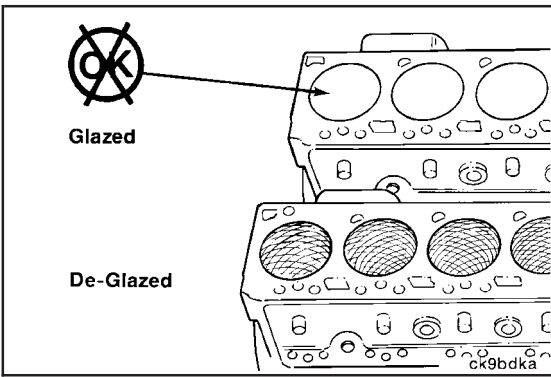

During repair it is essential that the cylinder wall be deglazed so that new rings will seat against the cylinder wall. Failure of the rings to seat can result in high blowby and excessive oil consumption.

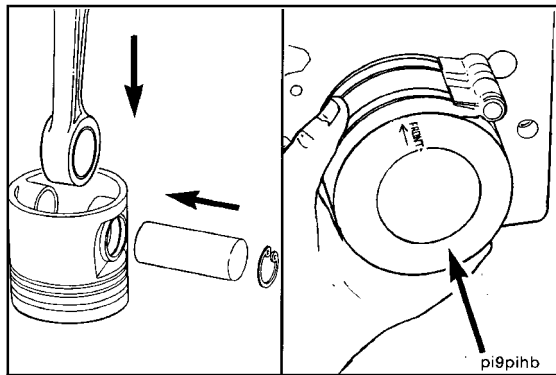

**Install (001-043-026)**

The piston and connecting rod **must** be installed as an assembly. Refer to Procedure 001-054.

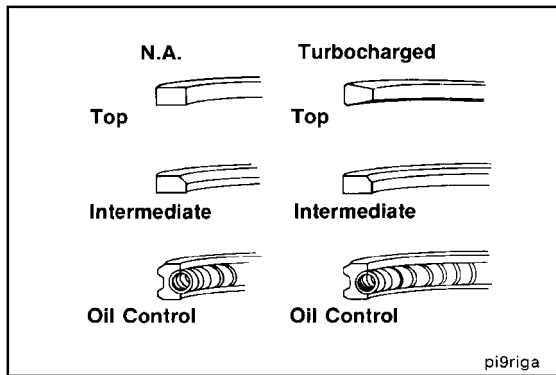

**Piston Rings (001-047)**

**General Information**

The piston ring sets are also different. While both sets consist of three rings, the top ring of the turbocharged/aftercooled set has a keystone profile that operates in a ni-resist insert cast into the piston. The naturally aspirated top ring is square cut and operates in a groove machined into the aluminum piston.

**NOTE:** The top ring for a turbocharged engine is **not** the same as the top ring for a naturally aspirated engine.

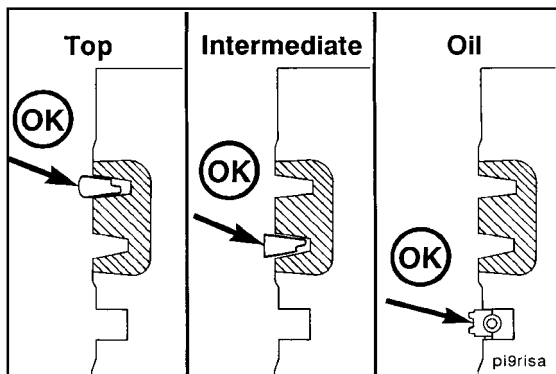

**Inspect for Reuse (001-047-007)**

Check the cylinder liners for wear. For those cylinders with no obvious damage, check the following conditions that can cause loss of sealing:

1. Piston rings installed incorrectly
2. Worn or damaged piston rings.

**NOTE:** There are two different designs of intermediate piston rings used:

- Rectangular
- Reverse Twist

Inspect the piston rings for the following:

- Abrasive wear.

**NOTE:** Abrasive wear is indicated by concentrated vertical scratches (B). The chromium plate is worn through and the face of the ring has a brighter finish compared to the dull satin finish of a new ring (A).

Abrasive wear can be caused:

1. Ingested abrasive material
2. Inadequate cleaning during a previous repair
3. Particles embedded in the liner.
4. Scuffing and scoring.

**NOTE:** Scuffing and scoring is indicated by heavy scratches, metal discoloration, and voids (B).

Scuffing and scoring can be caused by.

1. Engine overheating
2. Oil dilution
3. Improper maintenance of the lubrication system
4. Piston cooling nozzle malfunction.
5. Oil ring plugged by deposits.

**NOTE:** Scuffing and scoring on the piston rings indicates a breakdown of the oil film on the cylinder liner wall, causing transfer of material from the piston ring face to the cylinder liner.

**NOTE:** Oil ring plugging is indicated by deposits on the oil ring grooves (B).

Oil ring plugging can be caused by:

1. Low engine operating temperatures – long periods of idling or a cooling system malfunction
2. Extended oil change intervals
3. Use of the wrong grade of engine oil
4. Use of a poor-quality engine oil.

**NOTE:** Plugging of the oil ring drains restricts oil drain back, which floods the piston ring belt area, resulting in a loss of oil control.

**Measure (001-047-010)**

Use a new piston ring to measure the clearance in the ring groove.

	Ring Clearance		
	mm		in
Top	0.075	MIN	0.003
	0.150	MAX	0.006
Intermediate	0.085	MIN	0.003
	0.150	MAX	0.006
Oil Control	0.040	MIN	0.0016
	0.130	MAX	0.0051

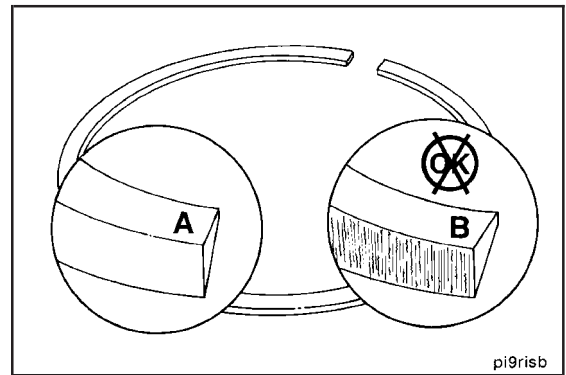

pi9risb

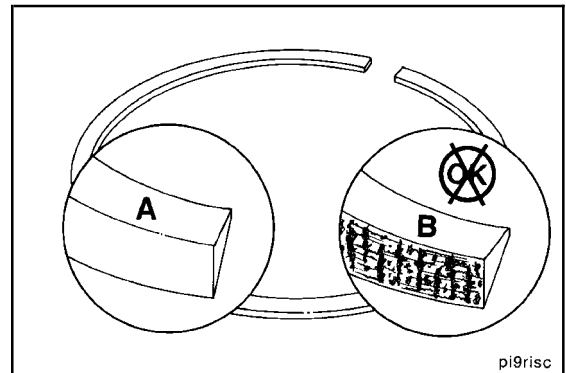

pi9risc

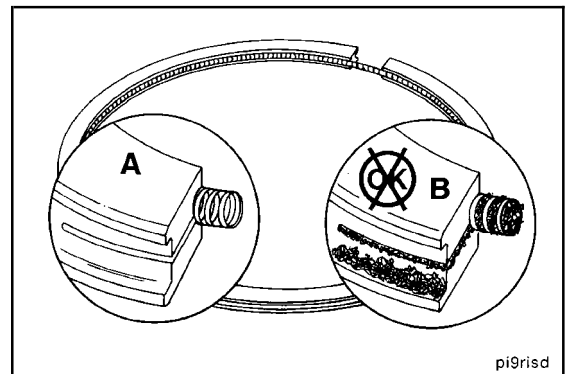

pi9risd

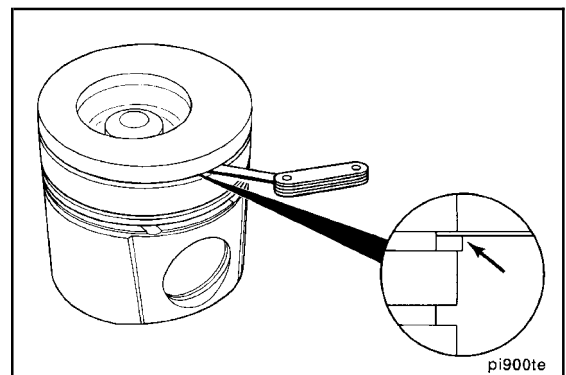

pi900te

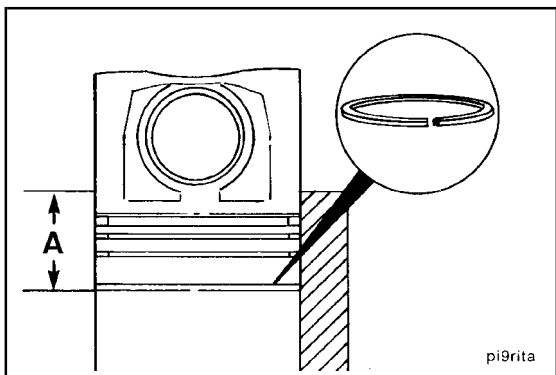

Position each ring in the cylinder 89 mm [3.5 in] below the top deck (A), and use a piston to square it with the bore.

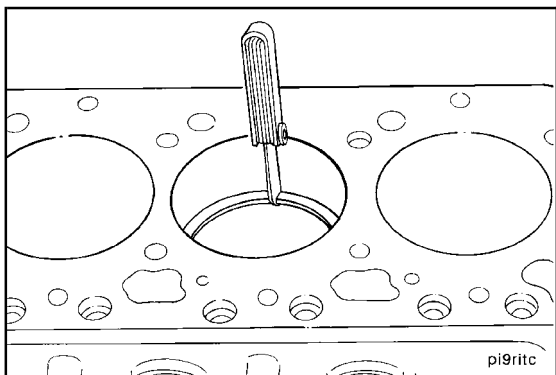

Use a feeler gauge to measure the gap.

	Ring Gap		
	mm		in
Top	0.40	MIN	0.0157
	0.70	MAX	0.0275
Intermediate	0.25	MIN	0.0100
	0.55	MAX	0.0216
Oil Control	0.25	MIN	0.0100
	0.55	MAX	0.0216

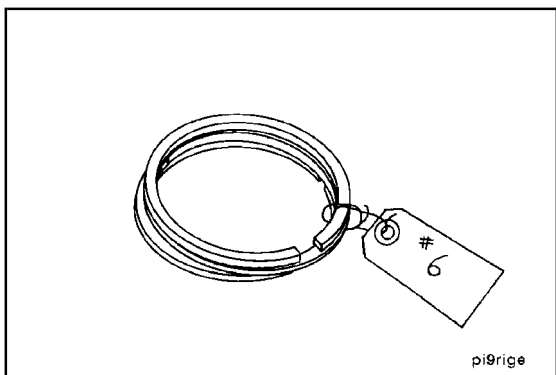

Identify the ring sets for installation in the cylinder where the end gap was measured.

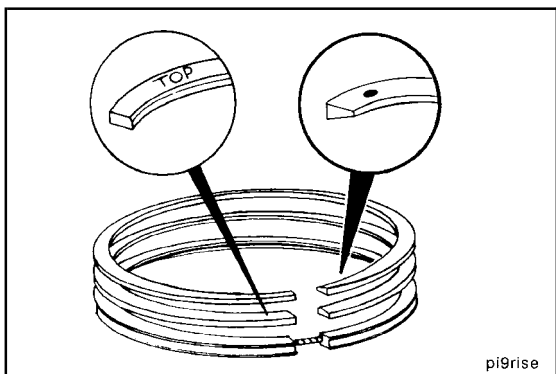

**Install (001-047-026)**

**⚠ CAUTION ⚠**

If a ring expander tool is being used, be careful not to over expand the ring.

The top surface of the top and intermediate rings are identified as illustrated.

The oil control ring can be assembled with either side up.



Position the oil ring expander in the control ring groove.

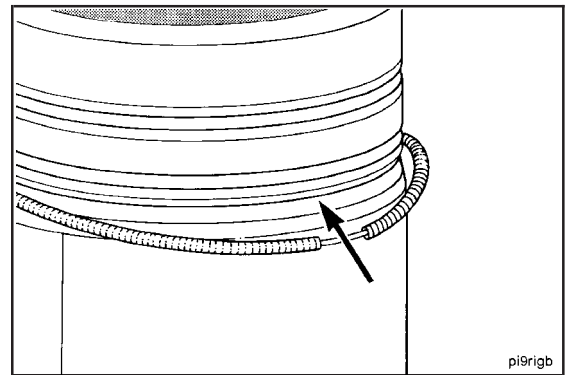

pi9rigb

Install the oil control ring with the end gap 180 degrees from the ends of the expander.

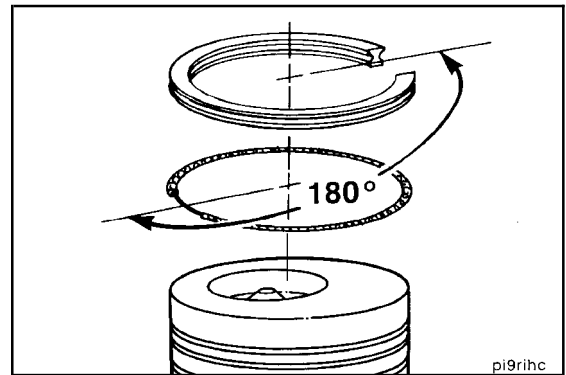

pi9rihc

**Piston Ring Expander, Part No. 3823137**

Install the intermediate ring.

**NOTE:** There are several styles of middle ring (A verses B), but all have a dark phosphate coating. Make certain that the dot and the word "TOP" are facing up when installing the piston.

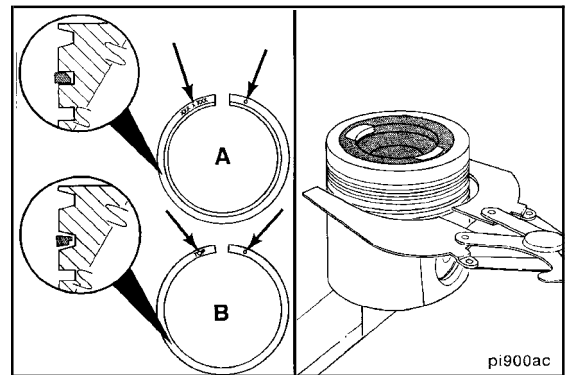

pi900ac

**NOTE:** The top ring for a turbocharged engine is **not** the same as the top ring for a naturally aspirated engine, however, they all have a shiny chrome appearance.

Install the top ring.

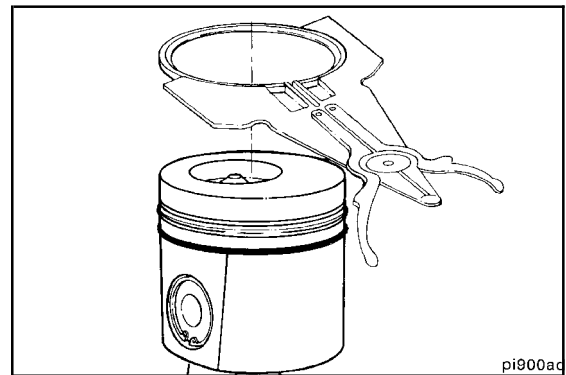

pi900ac

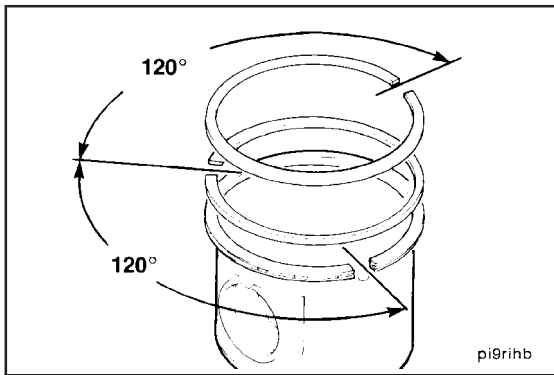

Position the rings so the ring gap are 120 degrees apart.

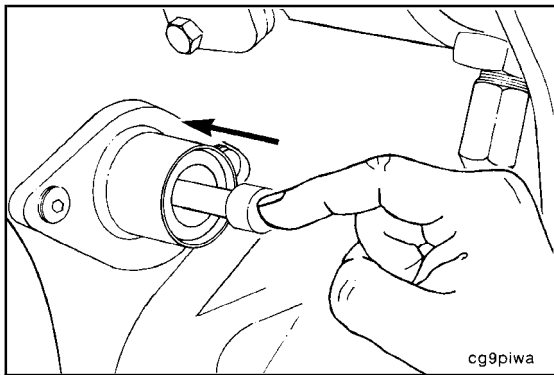

**Timing Pin Housing (001-049)  
Preparatory (001-049-000)**



**Engine Barring Tool, Part No. 3824591**

Locate top dead center (TDC) for cylinder No. 1 by barring crankshaft slowly while pressing on the engine timing pin.

Service Tip: If the timing pin has been damaged and can not be used to locate TDC, refer to Procedure 005-037.

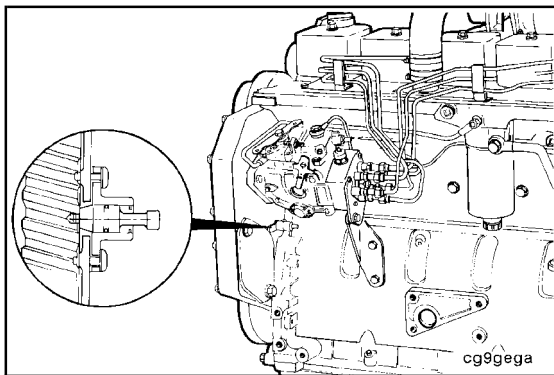

**Remove (001-049-002)**

**T-25 Torx®**



Remove the timing pin assembly and seal.

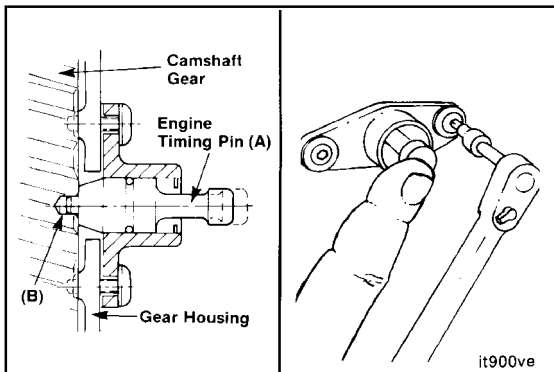

**Install (001-049-026)**

Install a new seal and, if required, new timing pin assembly. Hold the pin (A) in the hole (B) in the camshaft gear to align the housing.



**Torque Value: 5 N•m [48 in-lb]**

## Vibration Damper (001-052)

### General Information

The vibration damper controls the twisting or torsional vibration of the crankshaft. A vibration damper is engineered for use on a specific engine model.

It is **not** economical to repair a vibration damper in the field. Install a new or rebuilt vibration damper if the inspection indicates that a damper is defective.

The viscous vibration damper has a limited service life. The damper **must** be replaced if worn or damaged.

There are two different design vibration dampers used on the B Series engines:

- a. Viscous damper (A) for engines rated at speeds above 2500 rpm.
- b. Rubber element damper (B) for engines rated at speeds below 2500 rpm.

**NOTE:** The rubber vibration damper (B) is available either with or without the crankshaft adapter.

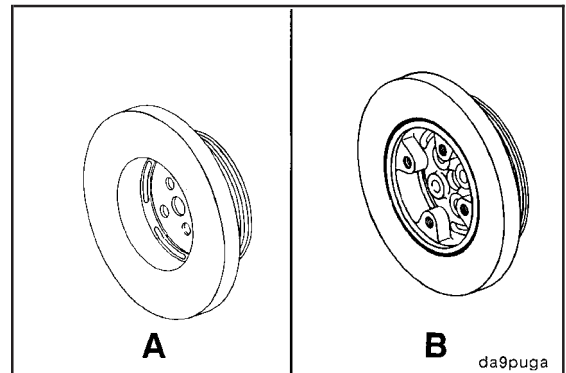

### Preparatory (001-052-000)

Remove the drive belt.

Refer to Procedure 008-002.

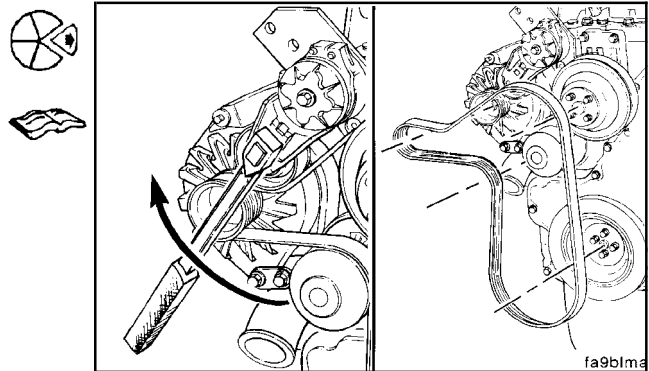

### Remove (001-052-002)

Remove the four capscrews.

Remove the vibration damper.

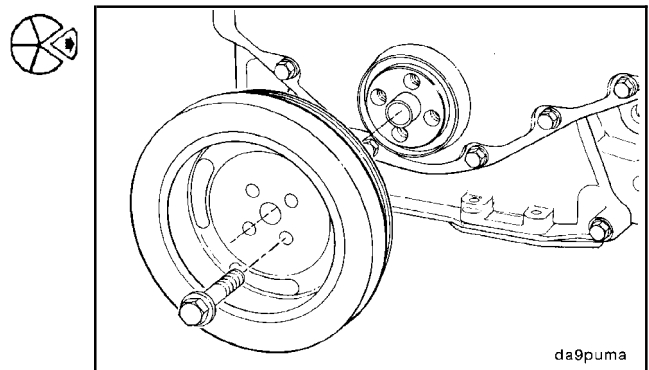

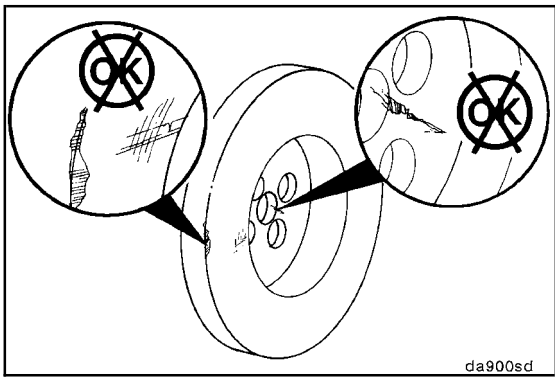

da900sd



**Inspect for Reuse (001-052-007)**

Check the mounting web for cracks. Check the housing for dents or raised surfaces. Replace the damper if any of these defects are identified.

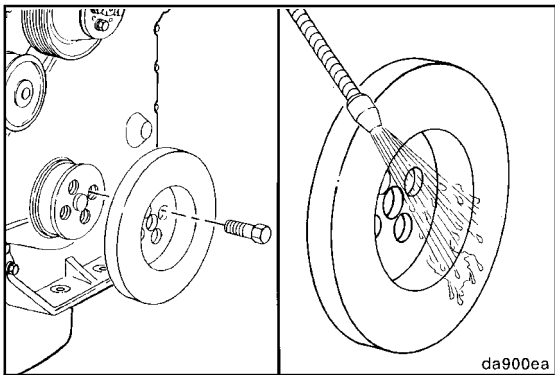

da900ea



**WARNING**

When using solvents, acids, or alkaline materials for cleaning, follow the manufacturer's recommendations for use. Wear goggles and protective clothing to avoid personal injury.



Clean the damper with solvent.

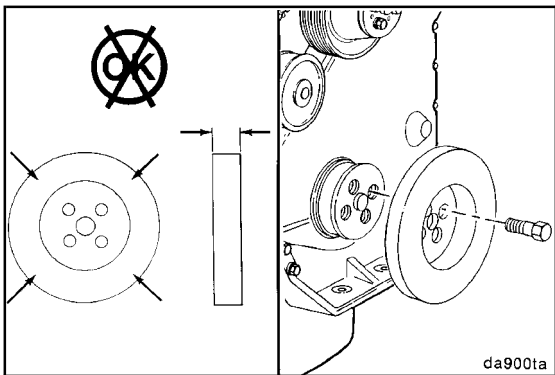

da900ta



**Viscous Damper**

The viscous damper is filled with a silicone fluid. After many hours of use, the silicone fluid can become thicker and expand. To determine if the damper thickness is correct, remove the paint from the damper in four locations on either side of the damper. Measure and record the thickness of the damper in four places. Measure the thickness 3.18 mm [0.125 in] from the outside of the damper. Replace the damper if its thickness varies by more than 0.25 mm [0.010 in].

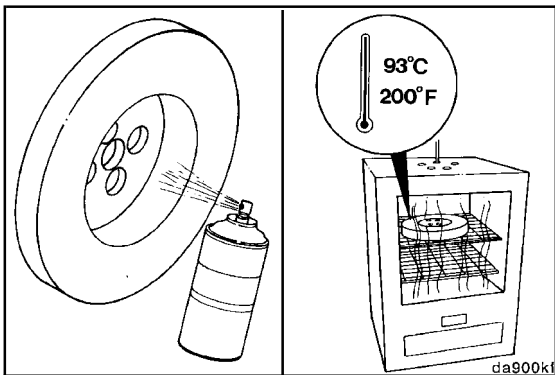

da900kf

Spray the damper with spot check developer, type SKD-NF, or its equivalent. Heat the damper in an oven (rolled lip side down) at 93°C [200°F] for 2 hours.



**WARNING**  
Wear protective gloves to prevent personal injury when handling parts that have been heated.

Remove the damper from the oven and check for fluid leakage. If there is leakage, replace the damper.

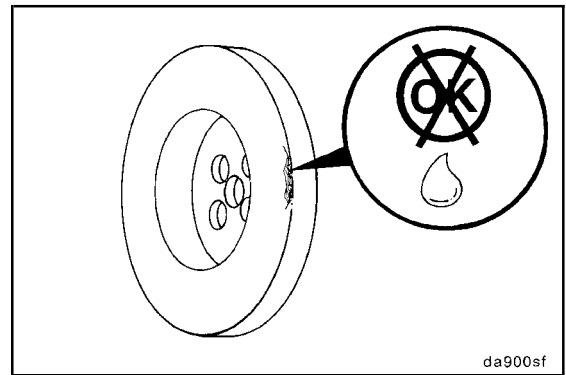

da900sf

**Measure (001-052-010)**

Measure the vibration dampers eccentricity.  
Install a dial indicator as illustrated.

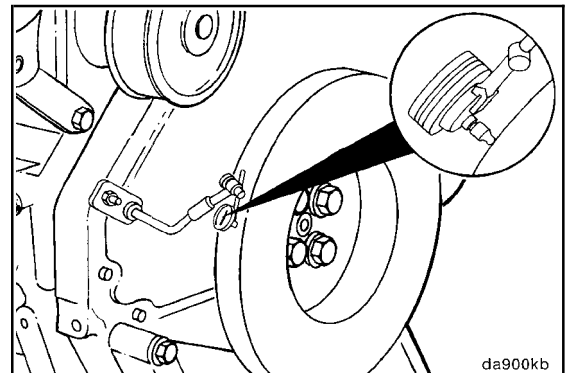

da900kb

Rotate the crankshaft with engine barring tool, Part No. 3377371.

Record the dial indicators movement.

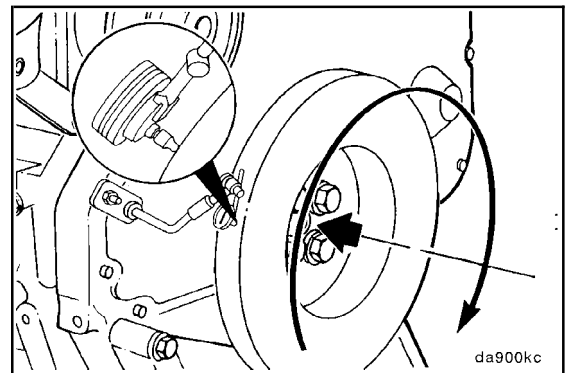

da900kc

**Vibration Damper Eccentricity per 25.4 mm [1.0 in] of Diameter**

mm		in
0.10	MAX	0.004

**NOTE:** If the eccentricity is **not** within specification the vibration damper **must** be replaced.

Measure the vibration damper wobble.

Install a dial indicator as illustrated.

Push the crankshaft to the front or rear and zero the dial indicator.

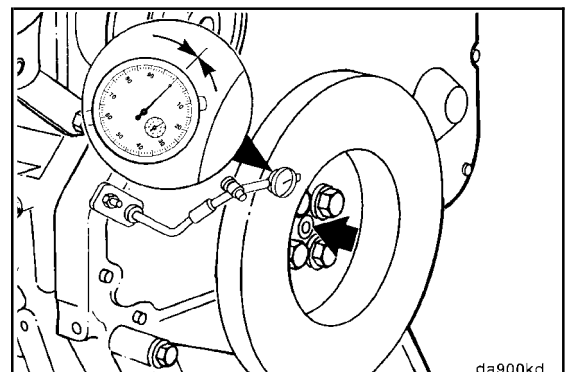

da900kd

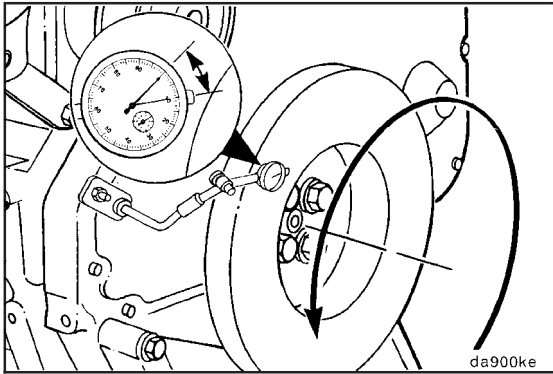

Rotate the crankshaft with engine barring tool, Part No. 3377371, 360 degrees, maintaining the position of the crankshaft.

Record the dial indicator movement.

**Vibration Damper Wobbleper 25.4 mm [1.0 in] of Radius**

mm		in
0.18	MAX	0.007

**Install (001-052-026)**

**NOTE:** The B Series engines have two configurations for the crankshaft pulleys and vibration dampers. Determine which configuration is used and use the appropriate steps in this procedure.

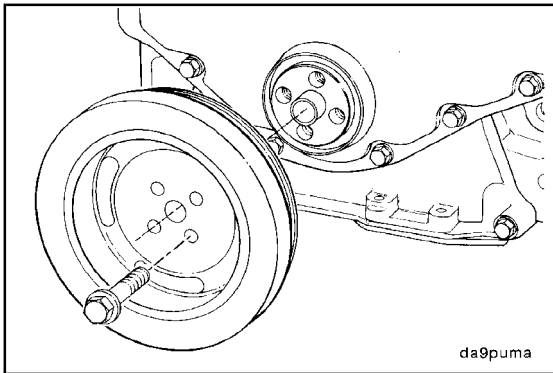

**One Piece Pulley/Vibration Damper**

Install the crankshaft vibration damper.

Install and tighten the crankshaft pulley/vibration damper capscrews.

**Torque Value:** 125 N•m [92 ft-lb]

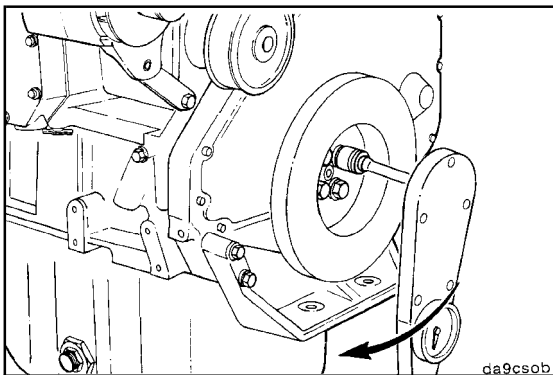

**Two-Piece Pulley/Vibration Damper**

Install the vibration damper.

Install and tighten the vibration damper capscrews.

**Torque Value:** 200 N•m [148 ft-lb]

Install the crankshaft pulley.

Install and tighten the crankshaft pulley capscrews.

**Torque Value:** 77 N•m [57 ft-lb]

Install the drive belt. Refer to Procedure 008-002.

**Service Tip:** If difficulty is experienced installing the drive belt (the belt seems too short), position the belt over the grooved pulleys first, and then, while holding the tensioner up, slide the belt over the water pump pulley.

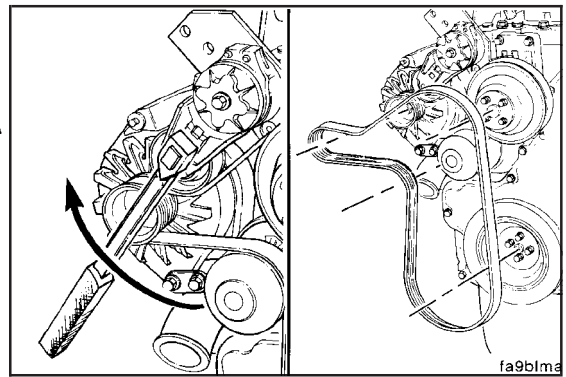

**Piston and Connecting Rod Assembly (001-054)**

**General Information**

There are a number of power-related problems, including excessive lubricating oil consumption, smoke, blowby, and poor performance, that can be caused by inadequate sealing between the piston rings and the cylinder walls. A blowby measurement can help detect the problem.

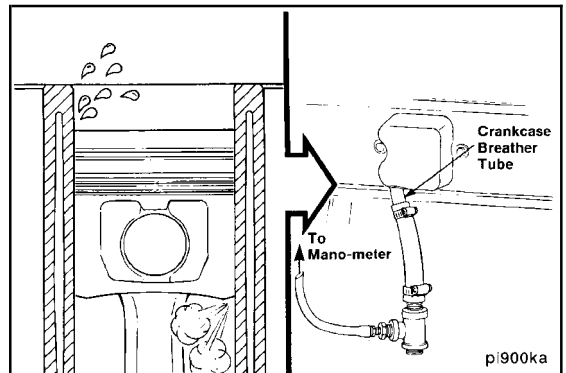

A free-floating, hollow piston pin is used to attach the piston to the connecting rod. Lubricating the pin and journal is accomplished by residual spray from piston cooling.

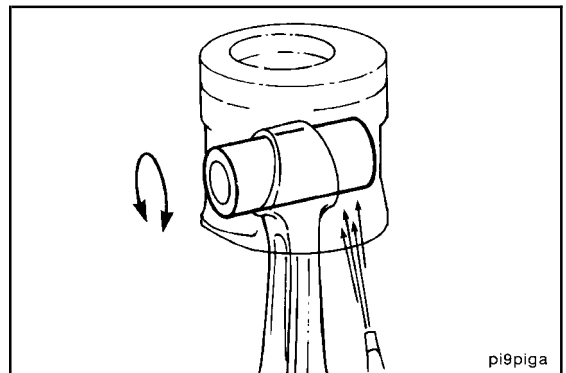

The piston pin end of the connecting rod is angle-cut to provide additional bearing surface. The connecting rod end is fitted with a bronze bushing.

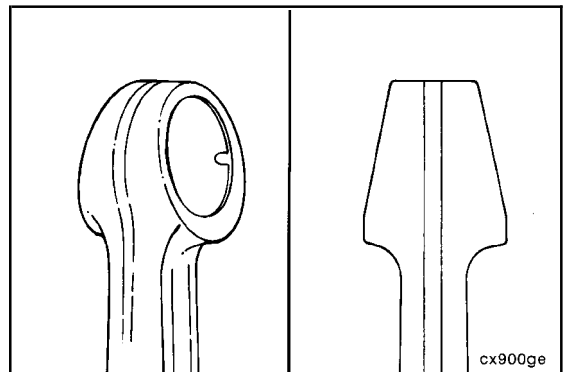

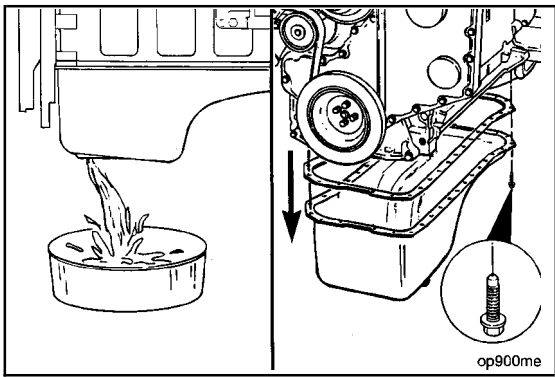

**Remove (001-054-002)**

**▲ WARNING ▲**



To avoid personal injury, avoid direct contact of hot oil with your skin.

Drain the lubricating oil. Refer to Procedure 007-025.

Remove the lubricating oil pan and gasket. Refer to Procedure 007-025.

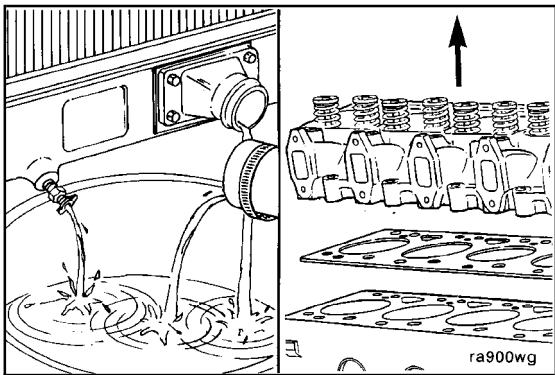

**▲ WARNING ▲**

Coolant is toxic. If not reused, dispose of in accordance with local environmental regulations.



Drain the coolant. Refer to Procedure 008-018.

Remove the cylinder head. Refer to Procedure 002-004.

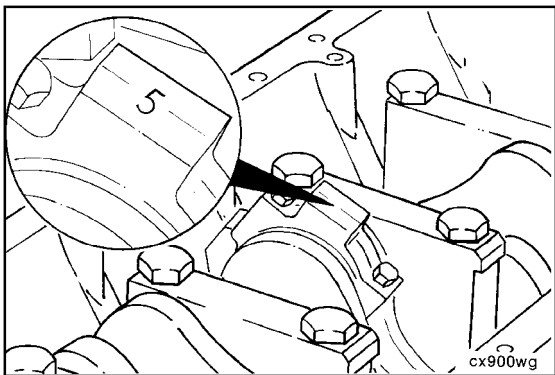

Mark each connecting rod cap according to cylinder.

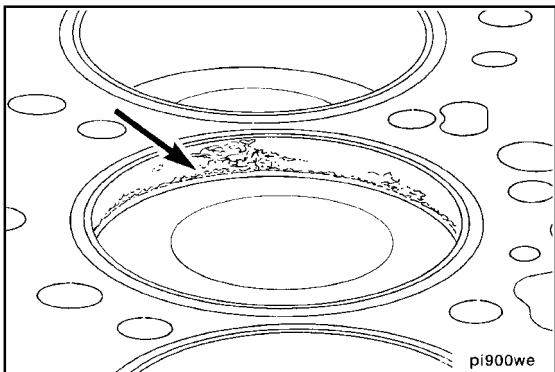

**Engine Barring Tool, Part No. 3824591**



Rotate the crankshaft with engine barring tool, Part No. 3824591, until the pistons are below the carbon deposits, which are found above the ring travel area.



**⚠ CAUTION ⚠**

Do not use emery cloth or sandpaper to remove carbon from the cylinder bores. Aluminum oxide or silicon particles from these materials can cause serious engine damage.

Use a scraper or a blunt-edged instrument to loosen the carbon deposits. Do **not** damage the cylinder with the scraper.

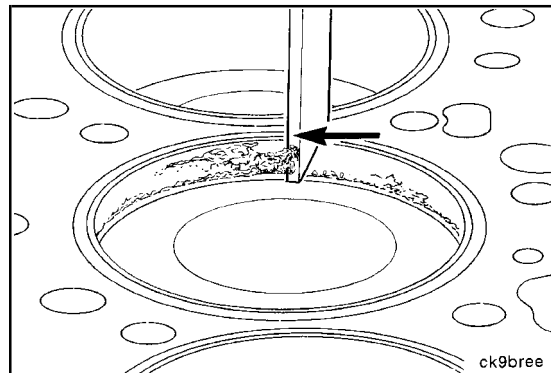

ck9bree

Remove the remaining carbon with a Scotch-Brite cleaning pad, or equivalent.

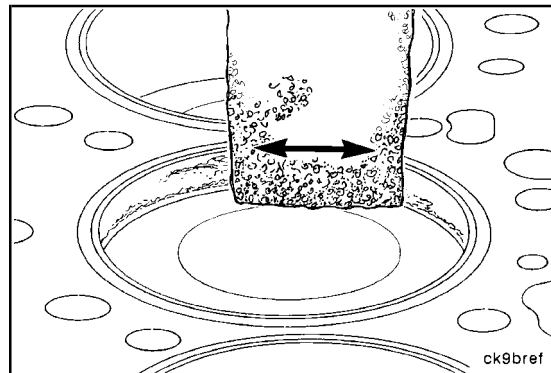

ck9bref

**12 mm**

Remove the capscrews, connecting rod cap, and connecting rod bearings. Refer to Procedure 001-005.

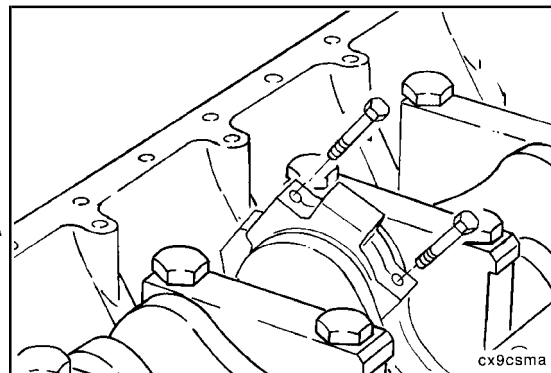

cx9csma

Push the connecting rod and piston assembly out of cylinder bore. Care **must** be taken **not** to mutilate the connecting rod or bearing.

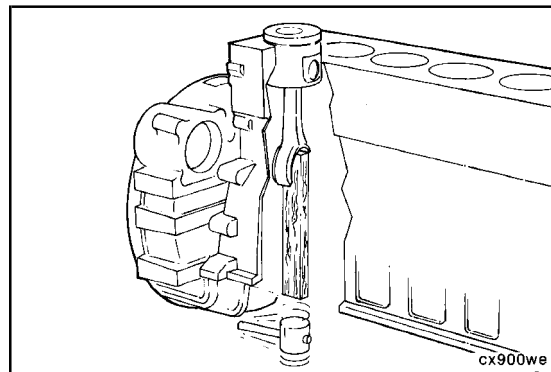

cx900we

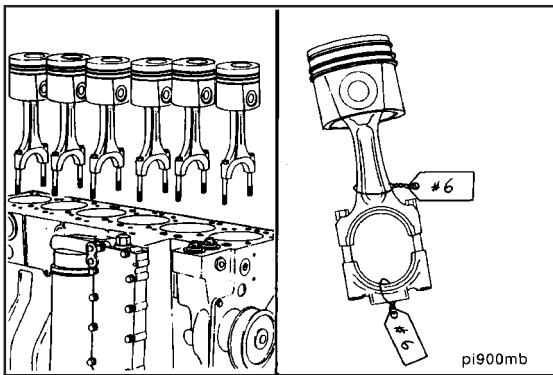

Use both hands to remove the piston and rod assembly.

**NOTE:** The piston and connecting rod assemblies **must** be installed in the same cylinder from which they were removed. This will allow for the proper fit of worn mating surfaces, if the parts are used again.

Use a tag to mark the cylinder number from which each piston and rod assembly was removed.

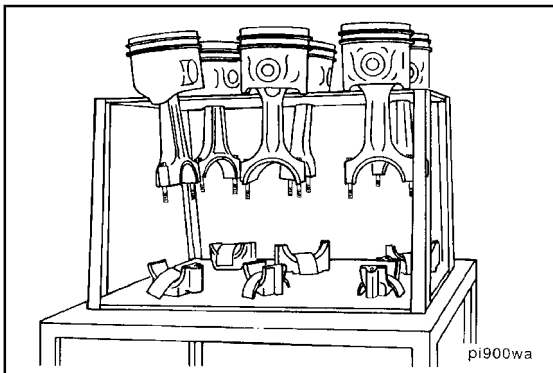

Place the connecting rod and piston assemblies in a container to protect them from damage.

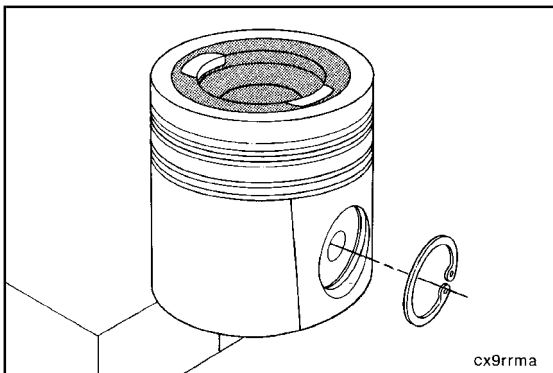

**Disassemble (001-054-003)**

Remove the retaining rings.

Refer to Procedure 001-047.

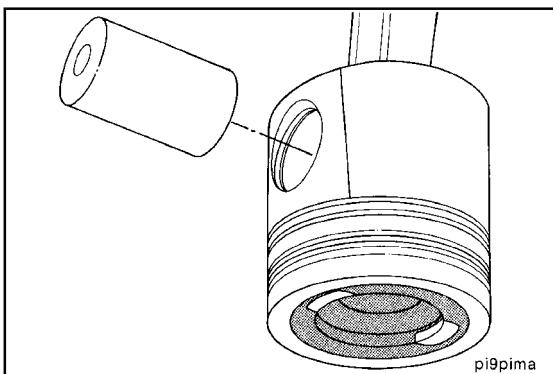

Remove the piston pin.

Refer to Procedure 001-043.

**NOTE:** Heating the piston is **not** required.



**Piston Ring Expander, Part No. 3823137**

Remove the piston rings.

**NOTE:** Refer to Procedure 001-043 for cleaning and inspection of pistons.

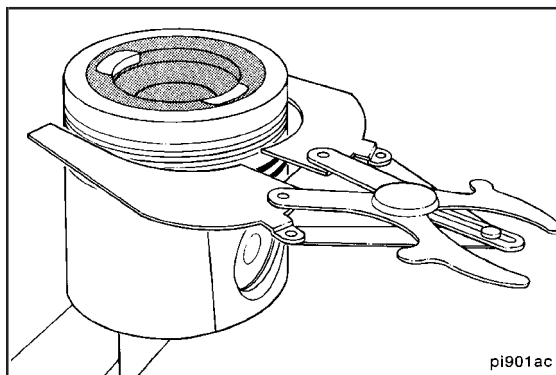

**Assemble (001-054-025)**

Be sure **FRONT** marking on piston and the numbers on the connecting rod and cap are oriented as illustrated.

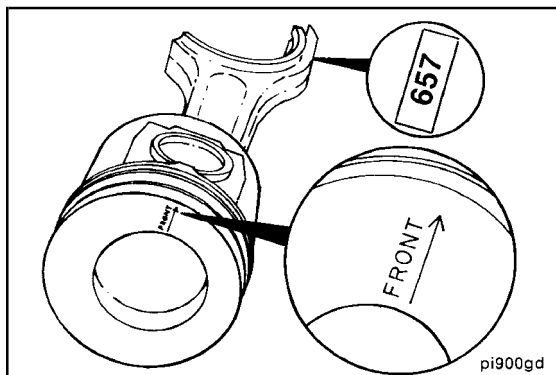

Install the retaining ring in the pin groove on the frontside of the piston.

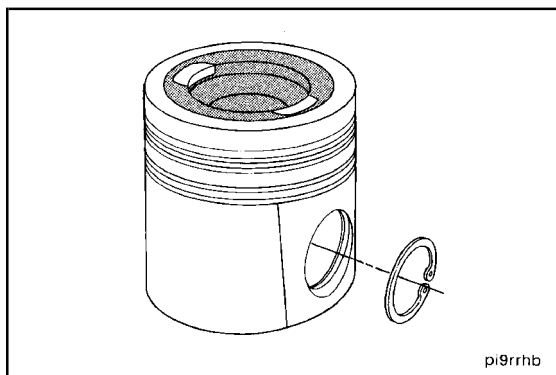

Lubricate the pin and pin bores with engine lubricating oil.

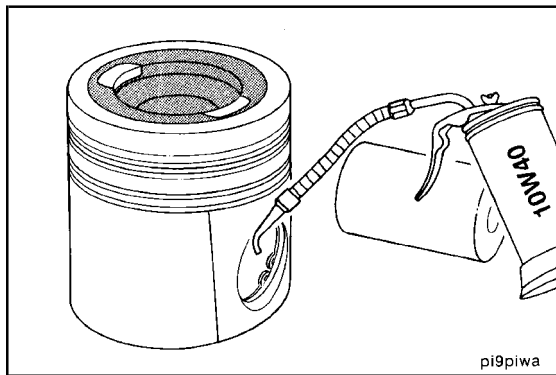

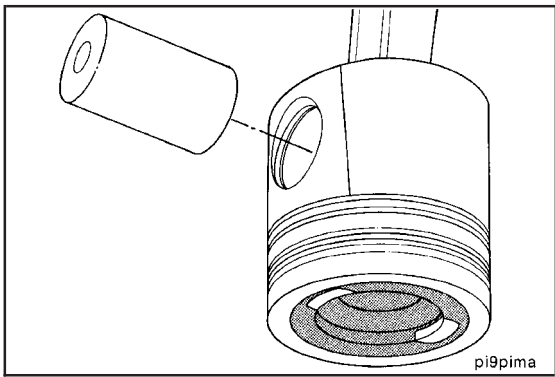

Install the pin. Refer to Procedure 001-043.

**NOTE:** Pistons do **not** require heating to install the pin; however, the pistons do need to be at room temperature or above.

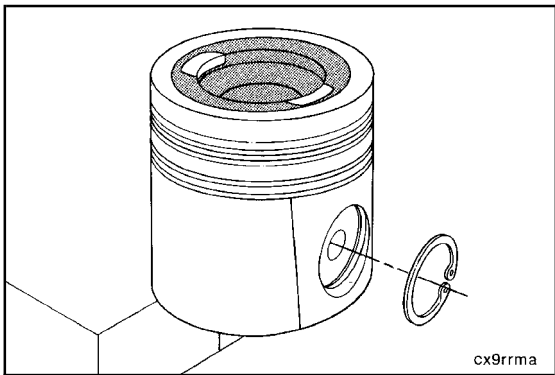

Install the second retaining ring.

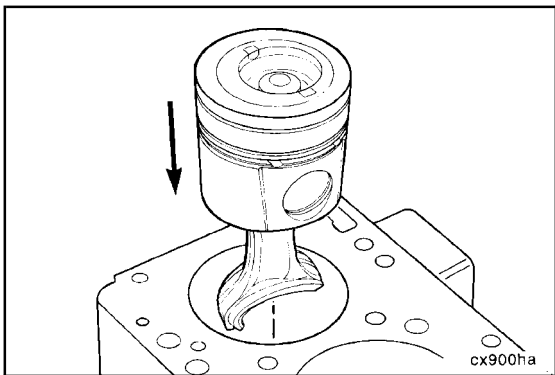

**Piston Grading**

When rebuilding an engine with the original cylinder block, crankshaft, and pistons, make sure the pistons are installed in the original cylinder.

If replacing the piston(s), make sure the replacement piston(s) are the same grade as the original piston.

If a new cylinder block or crankshaft is used, the piston grading procedure **must** be performed to determine the proper piston grade for each cylinder.

Install the connecting rod/piston assembly into the No. 1 cylinder without the rings installed.

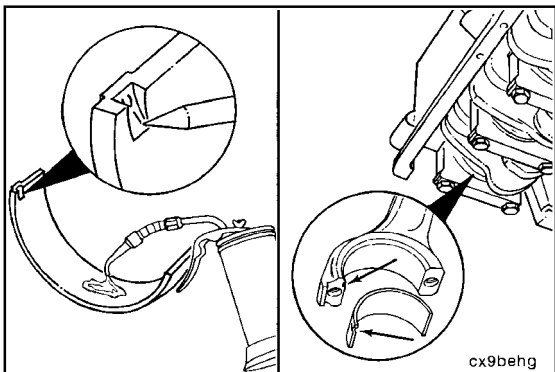

**NOTE:** The connecting rod bearings **must** be installed in the original connecting rod and cap.

Install the upper bearing shell in the connecting rod with the tang of the bearing in the slot of the connecting rod.



Use clean lubricating oil to coat the inside diameter of the connecting rod bearing shell.

**B3.9 and B5.9 Series Engines**  
**Section 1 - Cylinder Block - Group 01**

**Piston and Connecting Rod Assembly (001-054)**  
**Page 1-101**

Install the bearing shell in the connecting rod cap with the tang of the bearing in the slot to the cap.

Use clean lubricating engine oil to coat the inside diameter of the connecting rod bearing shell.

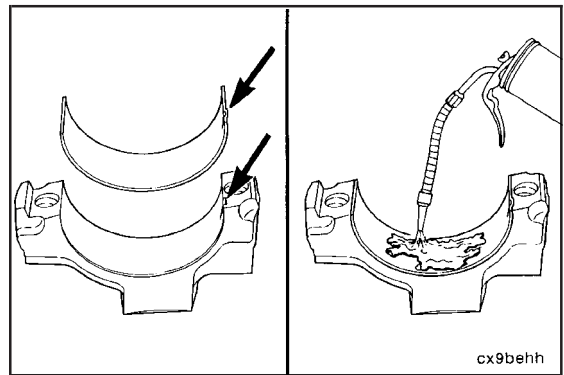

The number stamped on the connecting rod and cap at the parting line **must** match and be installed on the oil cooler side of the engine.

Install the connecting rod cap and capscrews to the connecting rod.

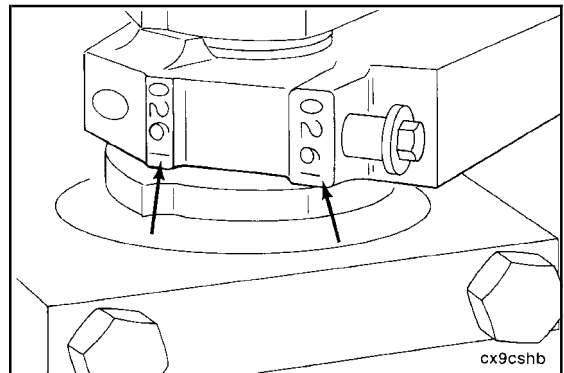

**12 mm**

Tighten the two capscrews.

**Torque Value:** 35 N•m [26 ft-lb]

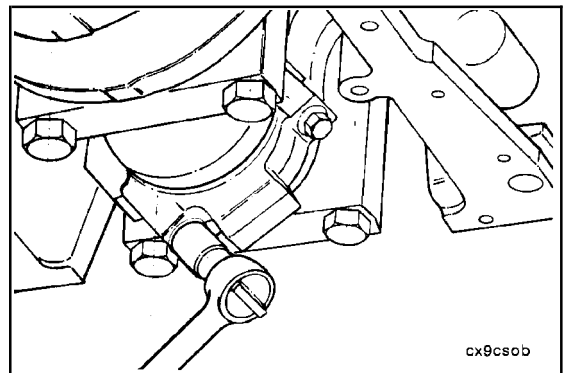

**Dial Indicator Assembly, Part No. 3823495**

Use a fine-grit paper to remove any burrs from the cylinder block head deck.

Zero the dial indicator to the cylinder block head deck.

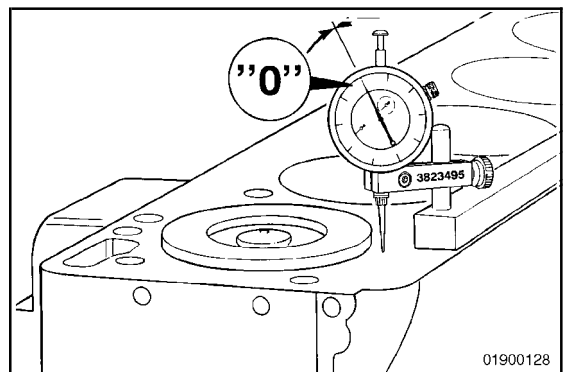

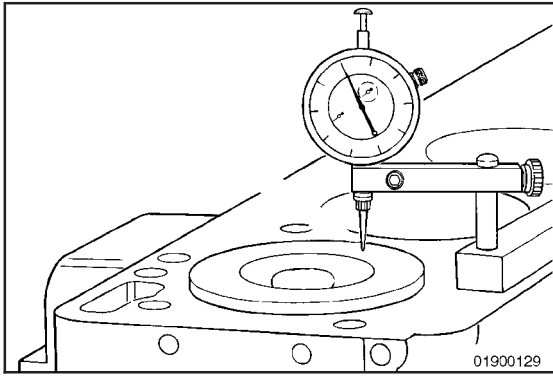

Move the dial indicator directly over the piston pin to eliminate any side-to-side movement. Do **not** place the indicator tip on the anodized area.

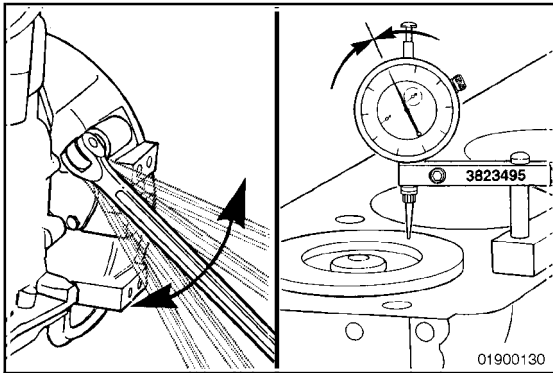

Rotate the crankshaft to top dead center (TDC). Rotate the crankshaft **clockwise** and **counterclockwise** to find the highest dial indicator reading.



Record the reading.

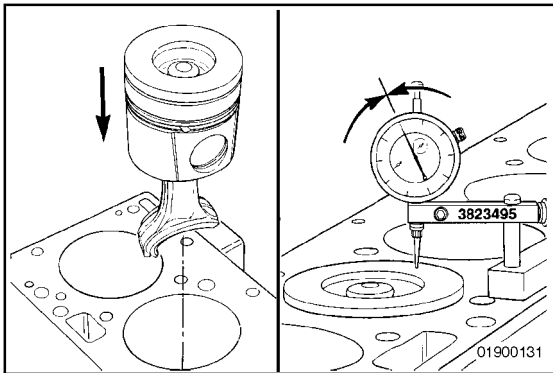

Remove the piston/connecting rod assembly from the No. 1 cylinder, and install the assembly into the No. 2 cylinder.



Repeat the procedure for every cylinder using the same piston/connecting rod assembly.

38mm-.609mm)	B	3942663	3942666	3943024
36mm-.508mm)	C	3942664	3942667	3943025
11mm-.813mm)	A	3942662	3942665	3943023
9mm-.711mm)	B	3942663	3942666	3943024
8mm-.609mm)	C	3942664	3942667	3943025
13mm-.914mm)	A	3942662	3942665	3943023
11mm-.813mm)	B	3942663	3942666	3943024
9mm-.711mm)	C	3942664	3942667	3943025

Protrusion is 0.024 to 0.028 inch.

01900132



The four digits on top of the piston are the last four digits of the part number. Using the measured piston protrusion and the grade of the piston that was measured, determine the piston grade required to obtain protrusion of 0.610 to 0.711 mm [0.024 to 0.028 in].

Piston Protrusion				
Piston	Protrusion	Use Grade	Part No. 160/175	Part No. 190/230
A	0.609 to 0.711 mm [0.024 to 0.028 in]	A	3922571	3922577
A	0.508 to 0.609 mm [0.020 to 0.024 in]	B	3922572	3922578
A	0.406 to 0.508 mm [0.016 to 0.020 in]	C	3922573	3922579
B	0.711 to 0.813 mm [0.028 to 0.032 in]	A	3922571	3922577
B	0.609 to 0.711 mm [0.024 to 0.028 in]	B	3922572	3922578
B	0.508 to 0.609 mm [0.020 to 0.024 in]	C	3922573	3922579
C	0.813 to 0.914 mm [0.032 to 0.036 in]	A	3922571	3922577
C	0.711 to 0.813 mm [0.028 to 0.032 in]	B	3922572	3922578
C	0.609 to 0.711 mm [0.024 to 0.028 in]	C	3922573	3922579

**Install (001-054-025)**

Install the bearing shells into both the connecting rod and the connecting rod cap. Make sure the tang on the bearing shells is in the slot of the connecting rod cap and connecting rod.

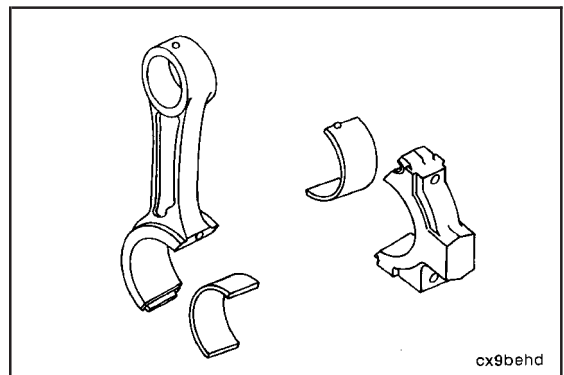

Lubricate the connecting rod bearings with a light film of clean lubricating engine oil.

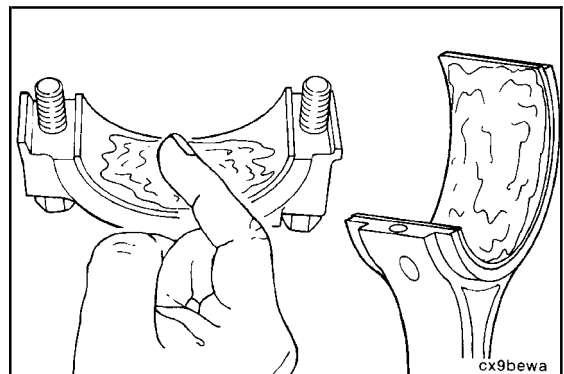

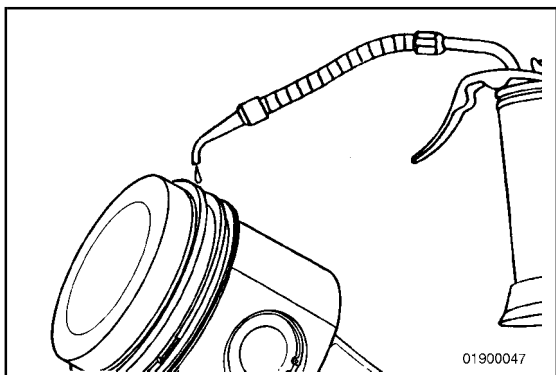

Install the piston rings. Refer to Procedure 001-047.  
Lubricate the rings and piston skirts with clean lubricating engine oil.

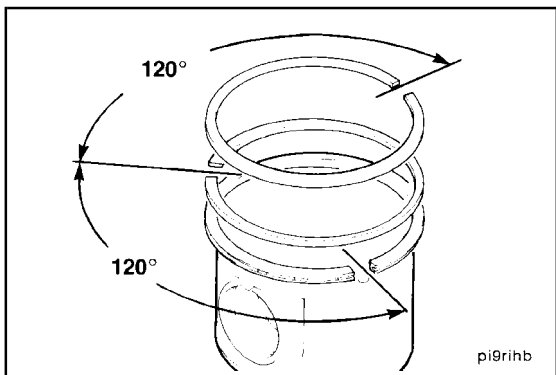

Position the rings so that the ring gaps are 120 degrees apart.

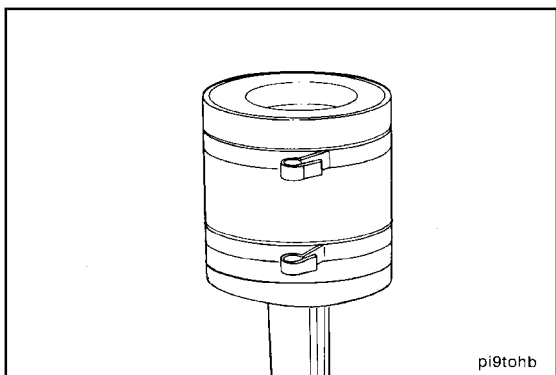

**Piston Ring Compressor, Part No. 3823290**  
75 to 125 mm [3 to 5 in]

**⚠ CAUTION ⚠**

If using a strap-type ring compressor, make sure the inside end of the strap does not hook on a ring gap and break the ring.

Compress the rings.

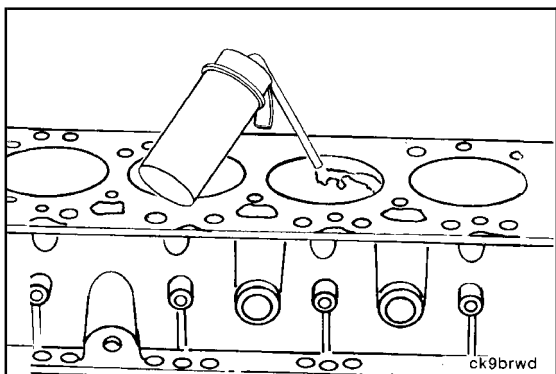

Lubricate the cylinder bore with clean lubricating engine oil.



Position the connecting rod journal for the piston to be installed to bottom dead center (BDC).

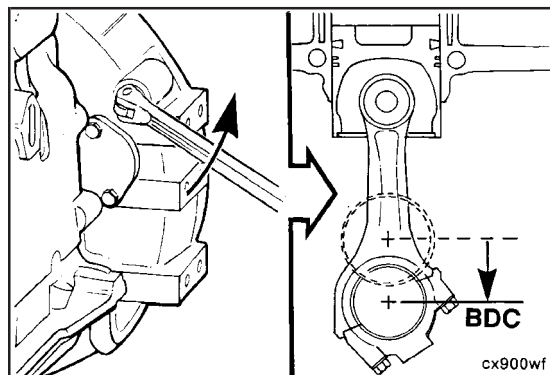

Take care **not** to damage the cylinder wall when inserting the connecting rod.

Position the piston and connecting rod assembly into cylinder bore with the word **FRONT** on the piston toward the front of the cylinder block.

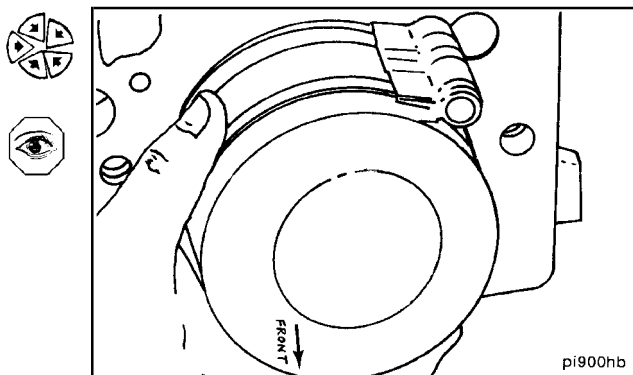

Carefully push the piston into the bore while guiding the connecting rod to the crankshaft journal.

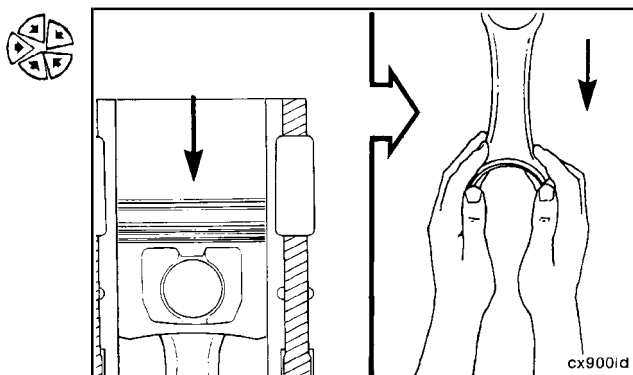

Lubricate the threads and underside of the connecting rod capscrew heads with clean lubricating engine oil.

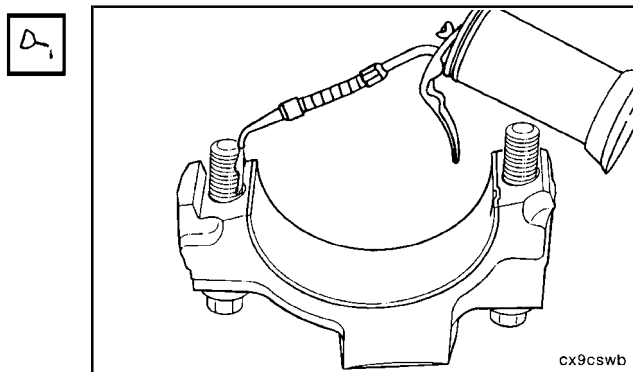

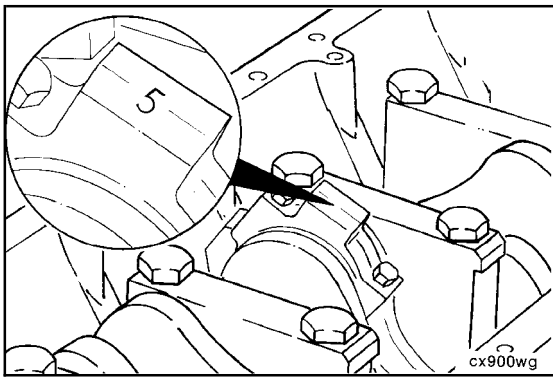

**NOTE:** The number stamped on the rod and cap at the parting line **must** match and be installed on the oil cooler side of the engine.

Install the connecting rod cap and capscrews to the connecting rod.

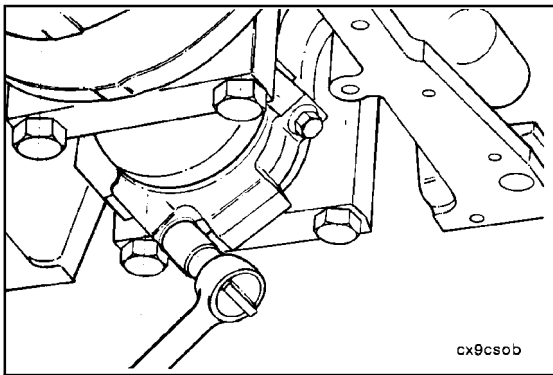

12 mm

Alternately, tighten the two capscrews.



**Torque Value:** Step 1 30 N•m [22 ft-lb]  
2 60 N•m [44 ft-lb]  
3 Turn 60 degrees clockwise.

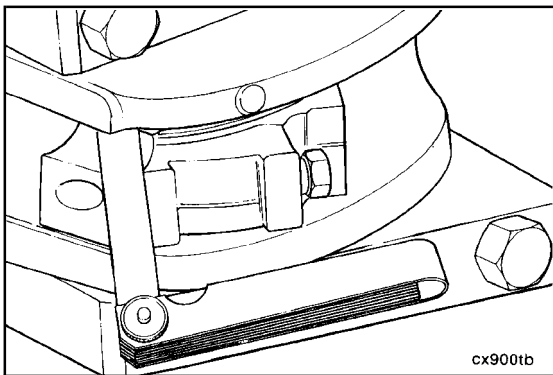

**NOTE:** Do **not** measure the clearance between the rod cap and crankshaft.

Measure the side clearance between the connecting rod and crankshaft.

Side Clearance Limits		
mm		in
0.10	MIN	0.004
0.33	MAX	0.013

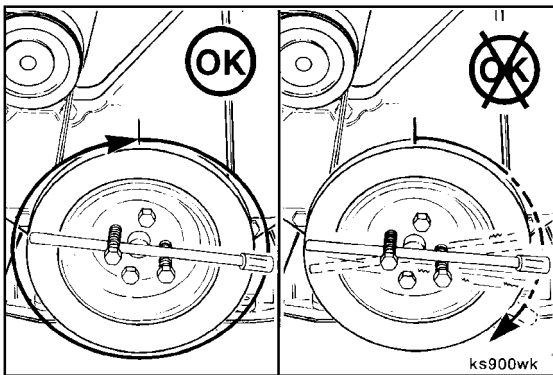

⚠ CAUTION ⚠

The crankshaft must rotate freely.

⚠ CAUTION ⚠

If the connecting rod is not properly oriented (tang opposite the camshaft), it will contact the camshaft and lock the engine.

Check for freedom of rotation as the connecting rod caps are installed. If the crankshaft does **not** rotate freely, check the installation of the connecting rod bearings and the bearing size.

**Three-Bond™ Sealant, Part No. 3823494**

**Oil Pan Sealing Surfaces - Sealants**

Use Cummins Sealant, Part No. 3823494, to fill the joints between the lubricating oil pan rail, gear housing, and rear cover.

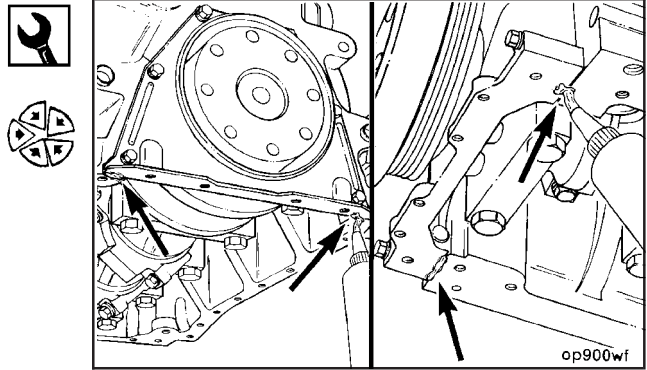

Install the lubricating oil pan and gasket. Refer to Procedure 007-025.

Fill the lubricating oil pan. Refer to Procedure 007-025.

Refer to the Operation and Maintenance Manual, B Series Engine, Bulletin No. 3810205, for correct oil specifications.

**Torque Value:** 24 N•m [18 ft-lb]

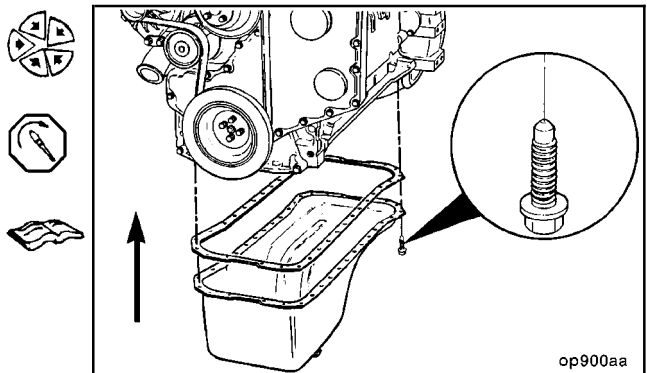

**10 mm**

Install the cylinder head. Refer to Procedure 002-004.

Fill the cooling system. Refer to Procedure 008-018.

Fill the engine with lubricating oil. Refer to Procedure 007-025.

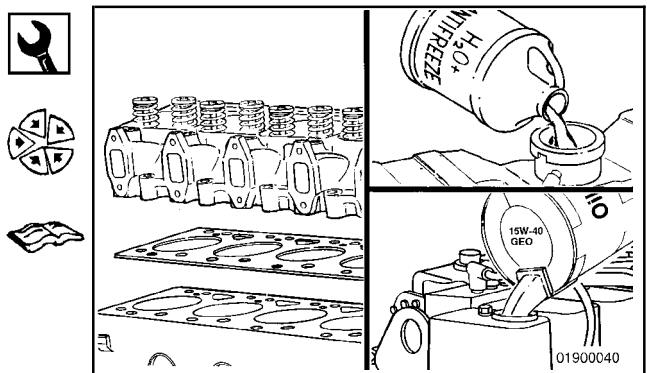

Operate the engine to normal operating temperature, and check for leaks.

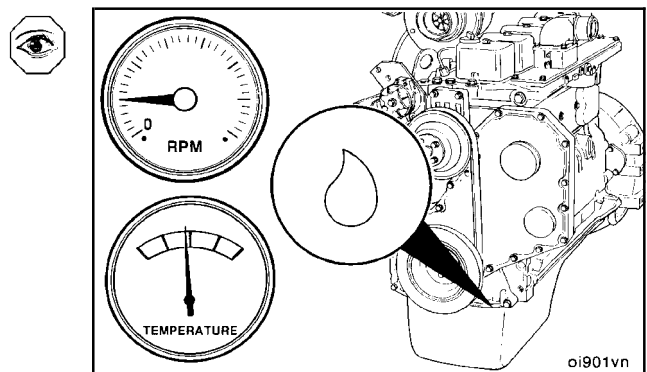

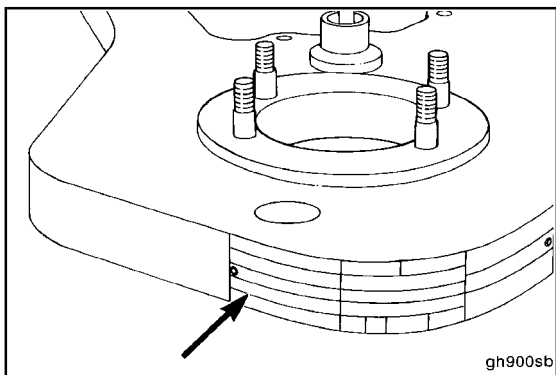

### Engine Dataplate (001-057)

#### Remove (001-057-002)

Remove the rivets that secure the dataplate to the gear housing.

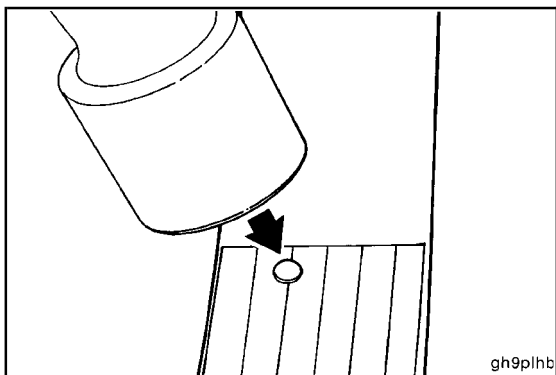

#### Install (001-057-026)

Drive the rivets in until they contact the dataplate.

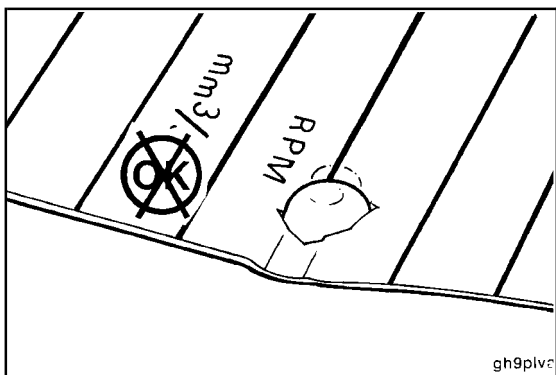

### ⚠ CAUTION ⚠

If the rivets are driven in too far, they will cut through the dataplates.

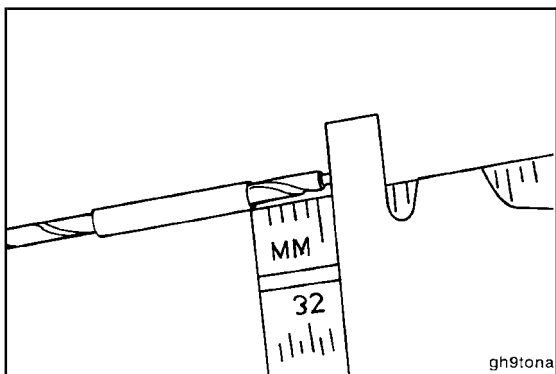

#### 2.0-mm Drill Bit

If the dataplate is loose or has been damaged, drill new holes, and attach with new rivets. Mark the drill bit at 6.0 mm [0.236 in] to avoid drilling too deeply into the gear housing.



Drill the dataplate, taking care **not** to destroy any data printed on the dataplate.

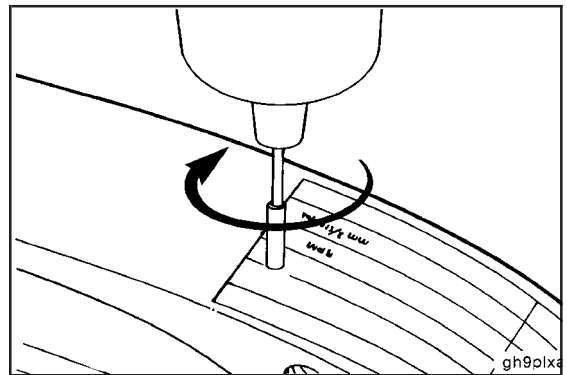

Drive the rivets in until they contact the dataplate.

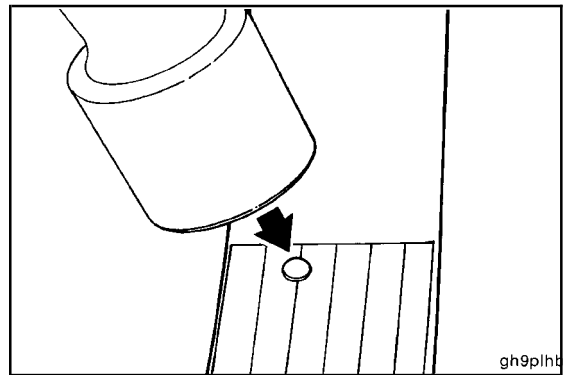

**Crankshaft Wear Sleeve, Rear (001-067)**

**General Information**

The rear crankshaft seal is mounted in a housing that bolts to the rear of the cylinder block. Double-lipped Teflon™ seals are used. The sealing surface on the crankshaft **must** be clean and free of lubricating oil during installation of the seal.

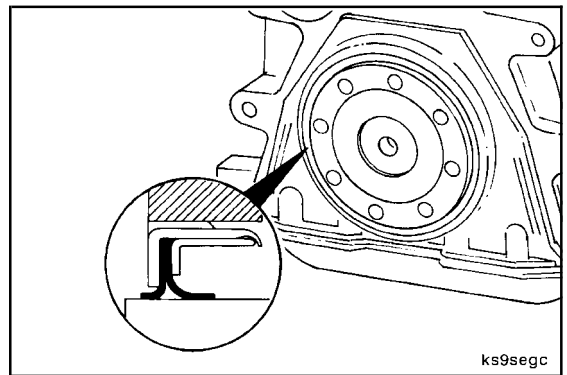

**Preparatory (001-067-000)**

If the crankshaft seal has worn a groove in the crankshaft flange, a wear sleeve **must** be installed to prevent oil leakage.

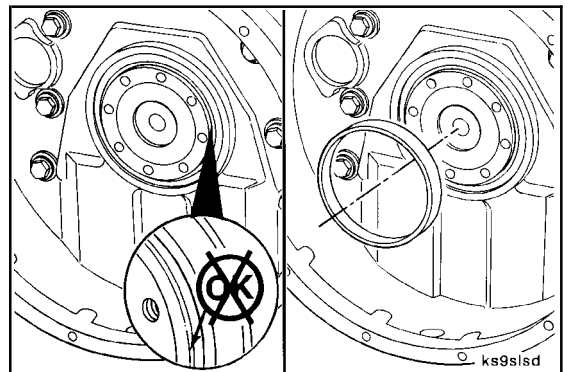

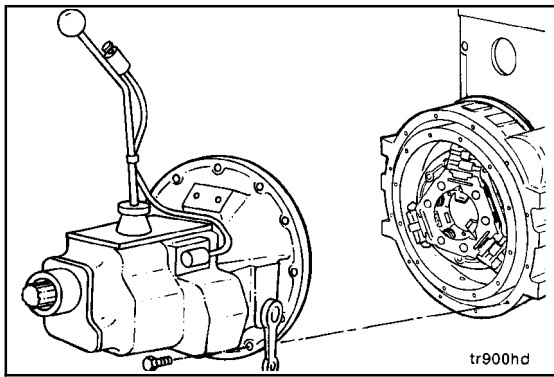

Disconnect the driveline, and remove the transmission, if equipped. Refer to the OEM service manual.

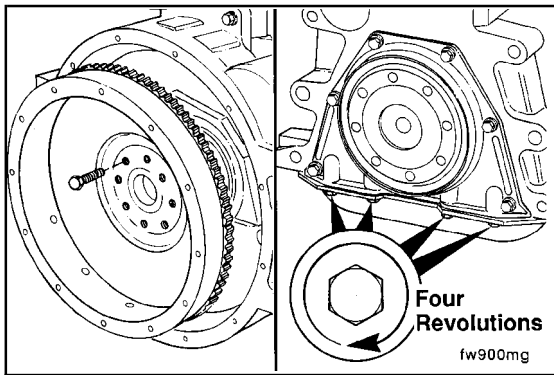

**Remove (001-067-002)**

19 mm



Remove the clutch and flywheel, if equipped.

Refer to Procedure 016-005 and the OEM service manual.

Remove the flywheel housing.



Refer to Procedure 016-006.

Loosen the lubricating oil pan mounting capscrews four revolutions.

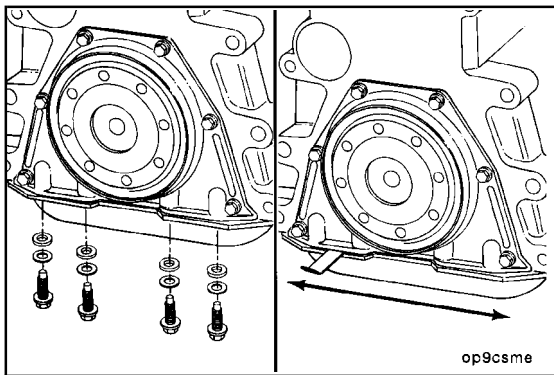

**CAUTION**

Use extreme care when releasing the oil pan gasket from the rear cover to prevent damage to the gasket.



Remove the four lubricating oil pan mounting capscrews that secure the oil pan to the rear cover.



Insert a feeler gauge or shim stock between the rear cover and the oil pan gasket. Move the feeler gauge or the shim stock back and forth to release the gasket from the rear cover.

If the gasket is damaged, the oil pan **must** be removed and the gasket replaced. Refer to Procedure 007-025.

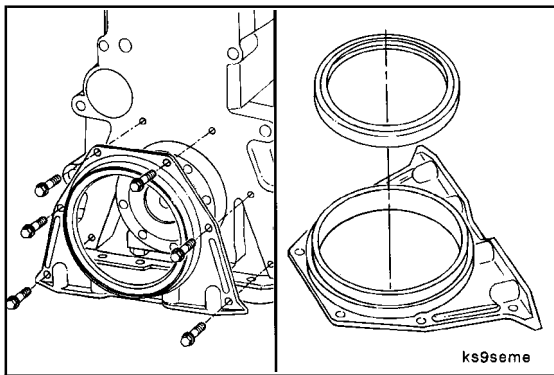

10 mm

Remove the capscrews from the rear cover, and remove the cover from the crankshaft flange.



Remove the seal from the rear cover.

**⚠ CAUTION ⚠**

Do not nick or gouge the crankshaft with the chisel. If the crankshaft is damaged, it must be replaced.

**Hammer, Chisel**

If the crankshaft currently has a wear sleeve, it **must** be removed before installing a new one.

Use a dull chisel that is **only** as wide as the wear sleeve.

Make one or two soft blows with a hammer to make chisel marks across the wear sleeve. This will expand the wear sleeve, allowing the sleeve to be removed.

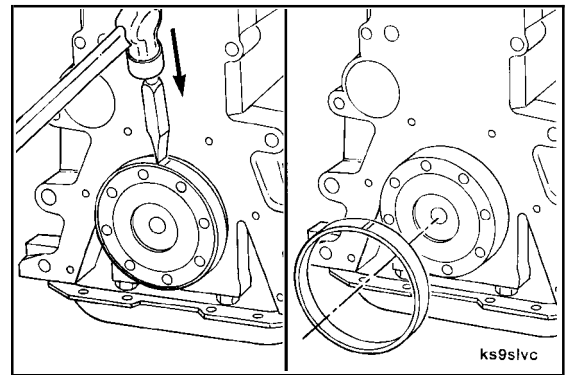

**Clean (001-067-006)**

**⚠ WARNING ⚠**

When using solvents, acids, or alkaline materials for cleaning, follow the manufacturer's recommendations for use. Wear goggles and protective clothing to avoid personal injury.

**⚠ WARNING ⚠**

Compressed air used for cleaning should not exceed 207 kPa [30 psi]. Wear appropriate eye and face protection when using compressed air. Flying debris and dirt can cause bodily injury.

Clean the gasket surface of the cylinder block and rear cover using solvent and a clean brush.

Dry these areas with compressed air.

Use a crocus cloth to remove any rust or other deposits from the crankshaft flange.

Use a clean cloth to clean the crankshaft flange.

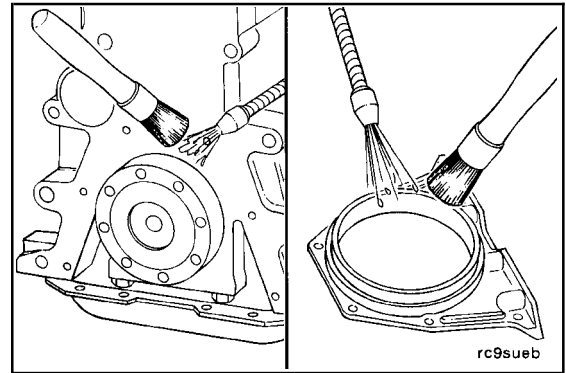

**Inspect for Reuse (001-067-007)**

Inspect the crankshaft flange for dirt or nicks.

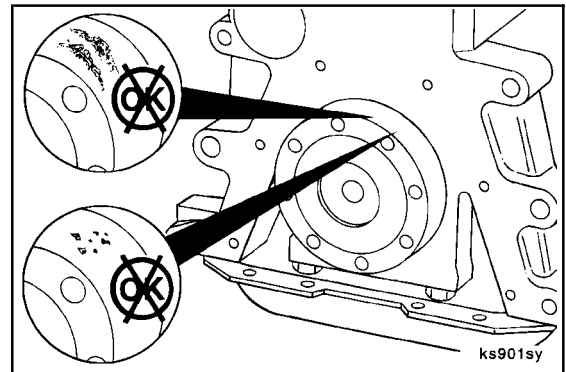

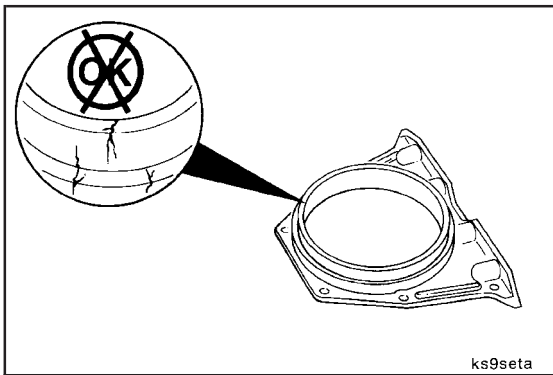

Inspect the rear cover for cracks or other damage.

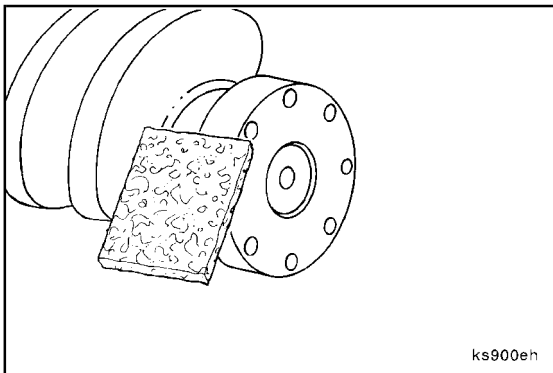

**Install (001-067-026)**

**NOTE:** Do **not** use any kind of lubricant to install the seal. The oil seal **must** be installed with the lip of the oil seal and the crankshaft clean and dry to be sure of proper oil sealing. Clean the lip of the oil seal of any existing lubricant.

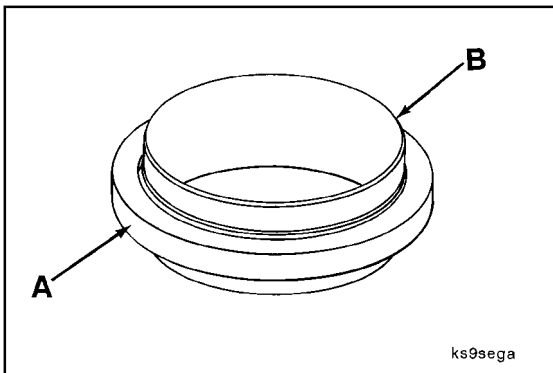

**NOTE:** The combination crankshaft oil seal (A) wear sleeve (B) replacement kit for service usage is installed on the crankshaft as an assembly. The crankshaft rear oil seal should **not** be removed from the crankshaft rear seal wear sleeve.

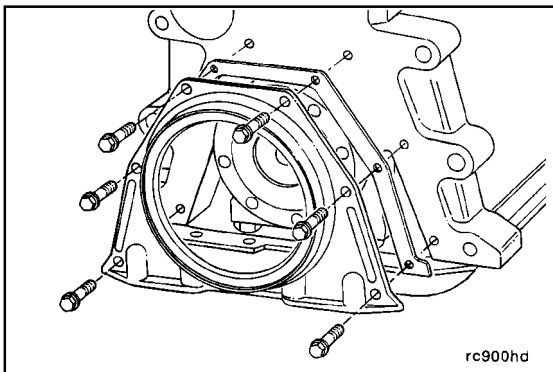

Install the rear cover and gasket.

Install the rear cover capscrews. Do **not** tighten.

**NOTE:** If the oil pan is installed, loosen the oil pan capscrews to allow clearance for rear cover and gasket clearance.

**NOTE:** The seal installation is being used to align the rear cover properly. Do **not** push or force the cover in any direction to prevent irregular seal lip position after seal installation.



**B3.9 and B5.9 Series Engines**  
**Section 1 - Cylinder Block - Group 01**

**Crankshaft Wear Sleeve, Rear (001-067)**  
**Page 1-113**

For a wet flywheel housing, use soap on the outside diameter of the seal case.

For a dry flywheel housing, nothing is required on the outside diameter of the seal case.

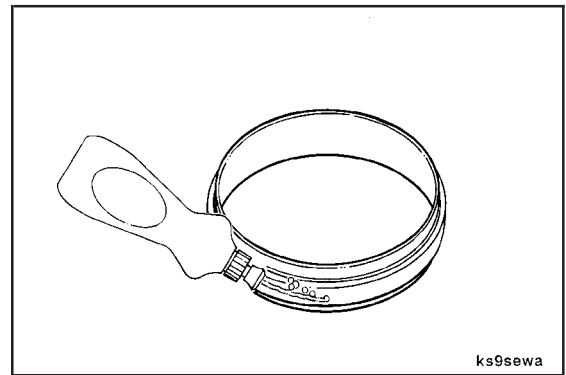

ks9sewa

**Crankshaft Rear Seal/Wear Sleeve Installation Tool, Part No. 3824078**

Use a service tool, Part No. 3824078, to install oil seal/wear sleeve assembly. Install two (2) threaded studs into the crankshaft capscrew holes.

Apply a small amount of clean lubricating engine oil to the crankshaft, threaded studs, and inside diameter of the crankshaft rear seal/wear sleeve installation tool.

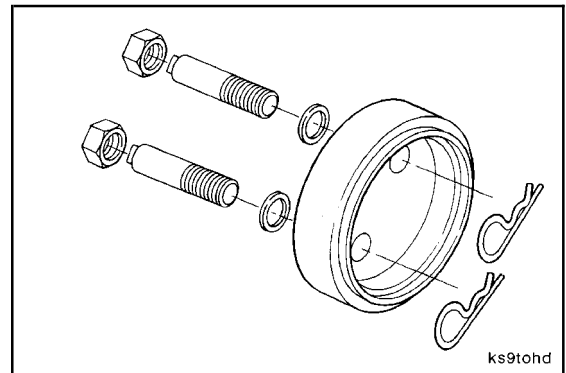

ks9tohd

Position the chamfered end of the wear sleeve (A) onto the end of the crankshaft (B). Position the counterbore end of installation tool (C) over threaded studs, and align with wear sleeve, perpendicular to the end of the crankshaft. Install the washers (D) and nuts (E) onto the threaded studs.

Alternately tighten the nuts one-half turn until the installation tool contacts the end of the crankshaft.

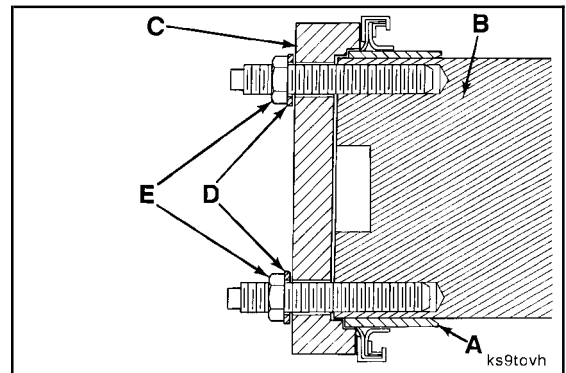

ks9tovh

**NOTE:** Do **not** exceed one-half revolution of each nut to prevent wear sleeve binding and irregular stretch.

**Torque Value:** 20 N•m [15 ft-lb]

Remove the installation tool and threaded studs.

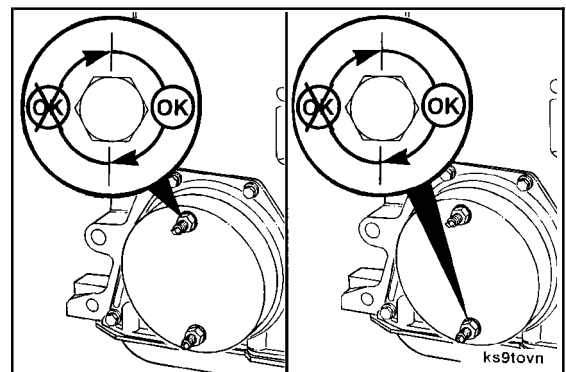

ks9tovn

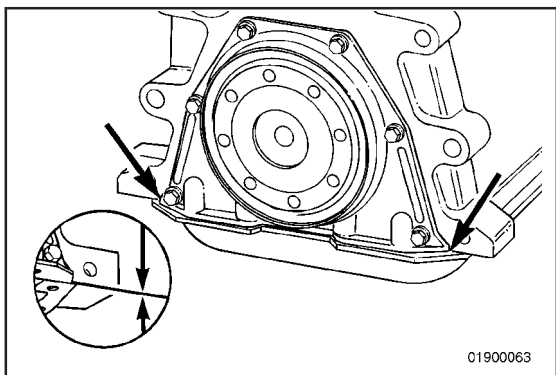

10 mm

Align the rear cover evenly with both sides of the oil pan rail on the cylinder block.

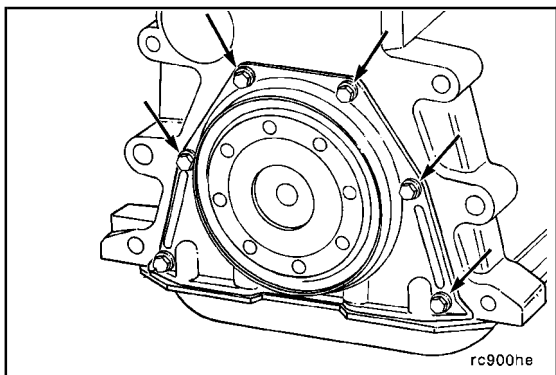

Tighten the rear cover cap screws.

**Torque Value:** 9 N•m [80 in-lb]

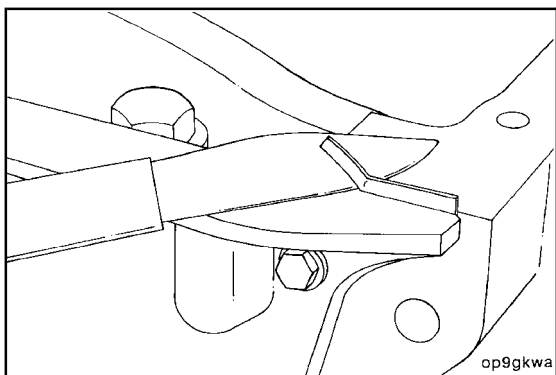

Trim the gasket evenly with the oil pan mounting surface.

**NOTE:** Make sure the gasket trim does **not** enter the engine.

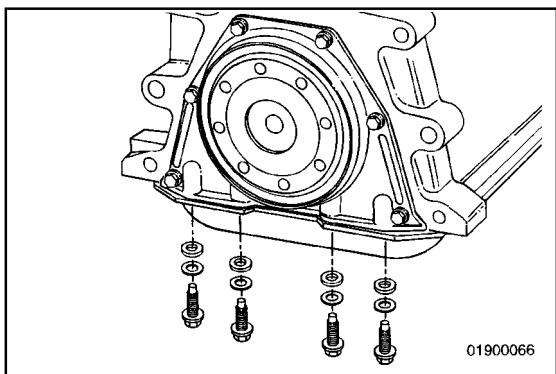

Install the four rear oil pan mounting cap screws to the pan.

**Torque Value:** 24 N•m [18 ft-lb]



Install the flywheel housing. Refer to Procedure 016-006.

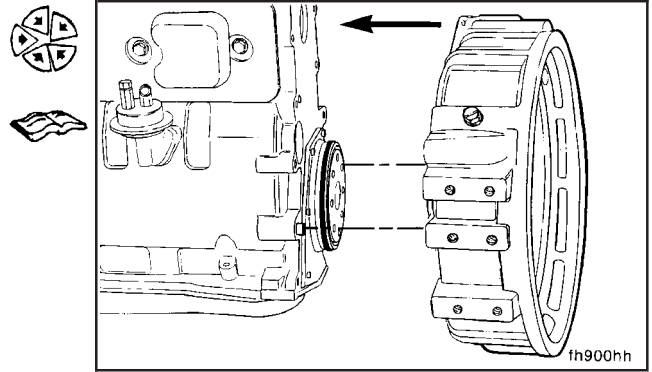

Install the flywheel and clutch, if equipped. Refer to Procedure 016-005 and the OEM service manual.

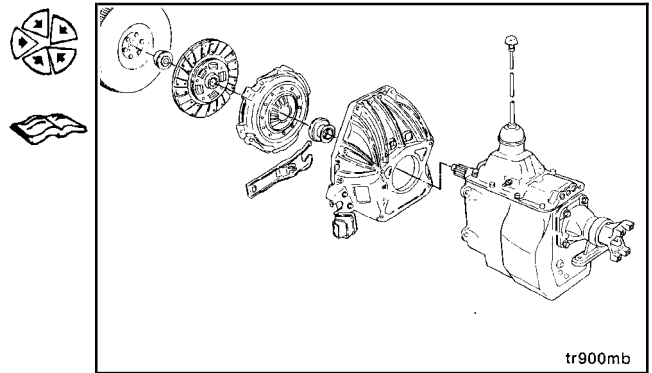

Operate the engine until coolant reaches 82°C [180°F] and check for leaks and proper operation.

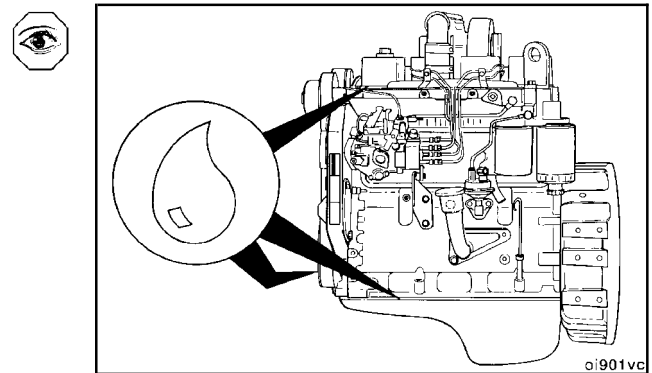



## Section 2 - Cylinder Head - Group 02

### Section Contents

	<b>Page</b>
<b>Cylinder Head</b> .....	2-3
Clean .....	2-6
Engine Noise Diagnostic Procedures - General Information .....	2-21
Inspect for Reuse .....	2-8
Install .....	2-11
Preparatory .....	2-3
Remove .....	2-5
<b>Cylinder Head - General Information</b> .....	2-2
Cylinder Head And Valve Train .....	2-2
<b>Cylinder Head Gasket</b> .....	2-29
Install .....	2-29
Remove .....	2-29
<b>Injector Protrusion</b> .....	2-29
General Information .....	2-29
<b>Service Tools</b> .....	2-1
Cylinder Head .....	2-1
<b>Valve, Cylinder Head</b> .....	2-22
Assemble .....	2-26
Clean .....	2-24
Disassemble .....	2-22
Inspect for Reuse .....	2-24
Install .....	2-28
Preparatory .....	2-22
<b>Valve Guide Seal, Cylinder Head</b> .....	2-21
Initial Check .....	2-21

**THIS PAGE LEFT INTENTIONALLY BLANK**

## Service Tools Cylinder Head

The following special tools are recommended to perform procedures in this section. The use of these tools is shown in the appropriate procedure. These tools can be purchased from your local Cummins Authorized Repair Location.

Tool No.	Tool Description	Tool Illustration
3377371	<b>Engine Barring Gear</b> Used to engage the flywheel ring gear to rotate the crankshaft.	A cylindrical metal tool with a square hole on one end and a splined shaft on the other. The part number 3377371 is stamped on the side.
3375962	<b>Valve Spring Compressor</b> Used to remove and install valve collets.	A U-shaped metal tool with a handle and a threaded rod. The part number 3375962 is stamped on the top. A reference number 01900067 is also visible.
3822509	<b>Injector Bore Brush</b> Used to clean carbon from injector bores.	A brush with a long handle and a cylindrical head containing bristles. The part number 3822509 is stamped on the handle.
3822513	<b>Tappet Removal Tool Kit</b> Used to remove and install valve tappets.	A kit consisting of several long rods, a small cup, and a circular component. The part number 3822513 is stamped on one of the rods.
3823878	<b>Torque Angle Gauge - 3/4-Inch Drive</b> Used to measure torque angle of capscrew.	A gauge with a cylindrical body and a handle. The part number 3823878 is stamped on the body.
3823921	<b>Capscrew Length Gauge</b> Used to measure capscrew free length.	A complex gauge with multiple measurement points and a scale. The part number 3823921 is stamped on the tool.

## Cylinder Head - General Information

### Cylinder Head and Valve Train

The cylinder head is a one-piece, cross flow design with two valves per cylinder. The head has integrally cast valve guides and hardened valve seat surfaces that can be repaired in a machine shop using the appropriate service parts.

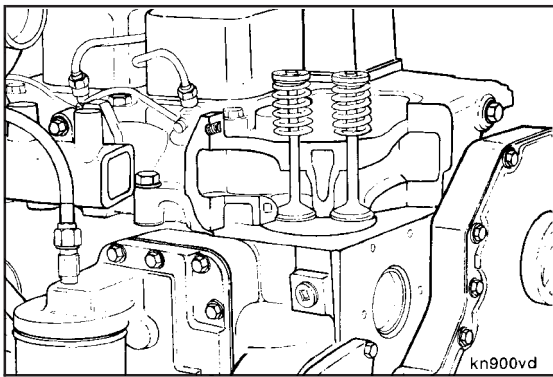

The cylinder head has a cast intake manifold, fuel filter head, thermostat housing and an internal water bypass. The injectors are mounted in the head for direct injection into the cylinders. Fuel filter head is remote for engines with in-line fuel injection pump.

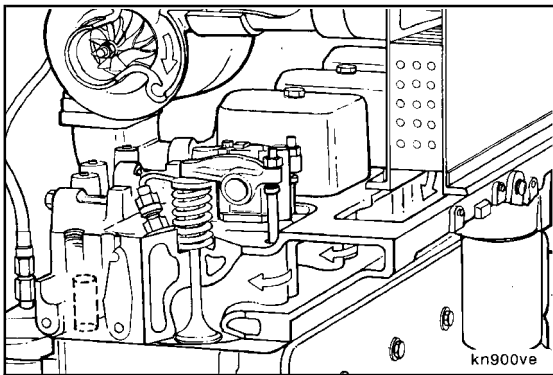

Separate pedestals for each cylinder are to support and route oil to the rocker levers.

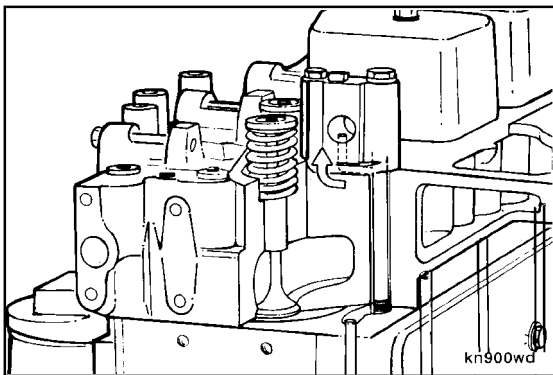

The cylinder head gasket is a specialized metal design with a printed o-seal on both sides around the water holes. An embossment in the gasket seals the cylinder bores. As discussed in the Cooling System, the gasket also provides orifices to control coolant flow.

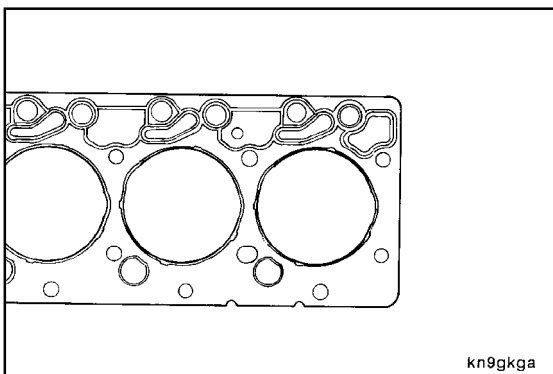



### Cylinder Head (002-004)

#### Preparatory (002-004-000)

**▲ WARNING ▲**

Coolant is toxic. If not reused, dispose of in accordance with local environmental regulations.

- Drain the coolant. Refer to Procedure 008-018.
- Remove all water and heater hoses. Refer to Operation and Maintenance Manual, B Series Engines, Bulletin No. 3810205 or the OEM service manual.

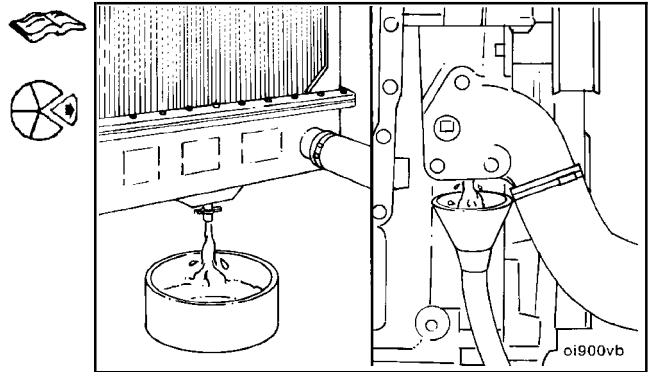

Remove the turbocharger and exhaust manifold. Refer to Procedures 010-033 and 011-007.

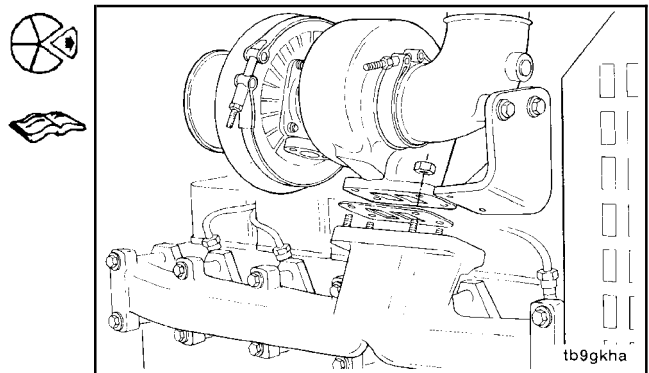

Remove the injectors and fuel lines. Refer to Procedures 006-026 and 006-051.

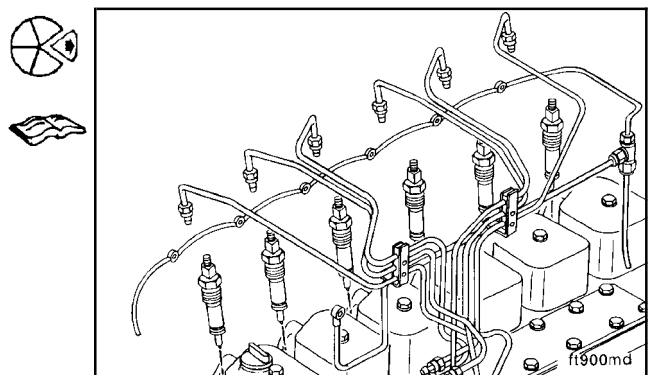

**▲ CAUTION ▲**

Tighten all head bolts if one individual pedestal is removed. Failure to do so can result in engine damage.

If one of the individual support pedestals is removed during inspection or repair, all head bolts **must** be retightened according to the head bolt torque sequence.

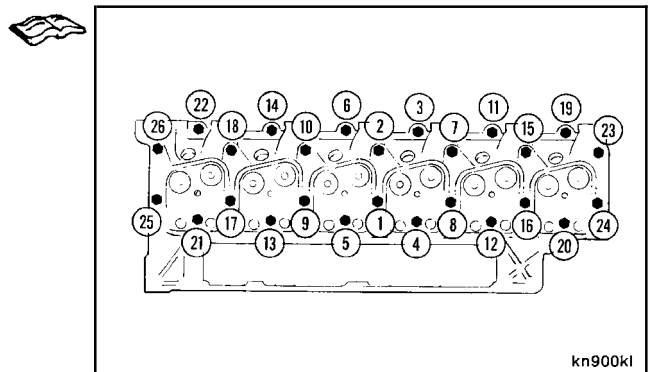

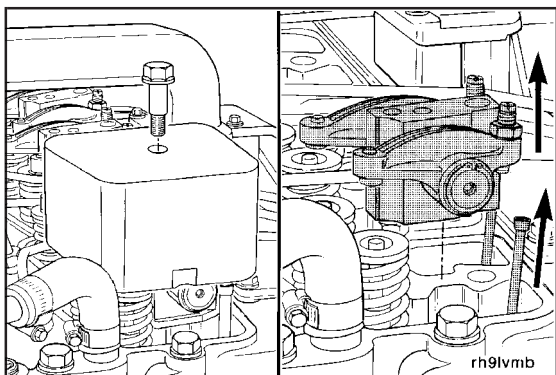

Remove the rocker lever cover, rocker levers, and pushrods. Refer to Procedures 003-011, 003-008, and 004-014.

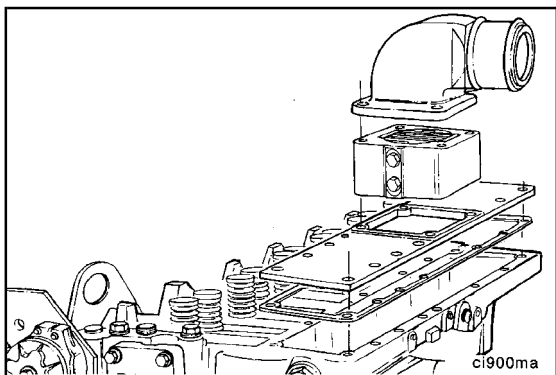

10 mm

Remove the intake manifold cover and intake heater (if equipped). Refer to Procedures 010-023 and 010-072.



**NOTE:** Note the manifold cover orientation for proper direction during installation.

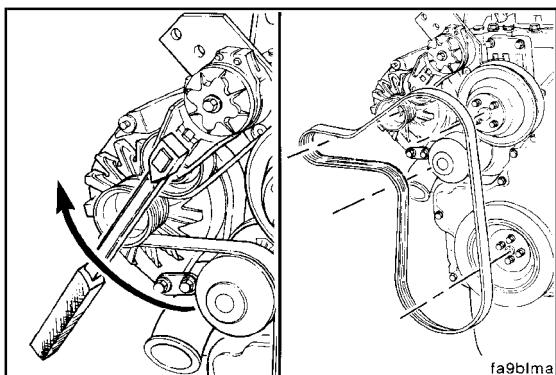

3/8-Inch Square Drive

Remove the drive belt. Refer to Procedure 008-002.



**NOTE:** Removal is easier if the crankshaft pulley is loosened before removing the belt.

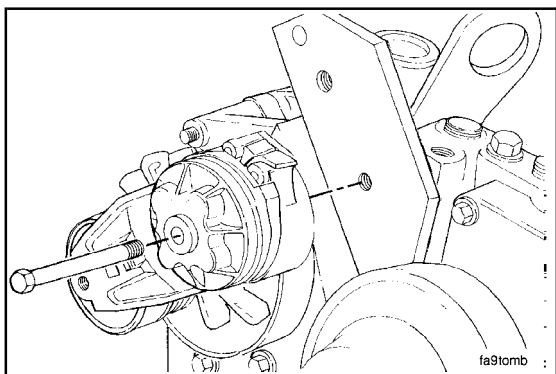

13-mm Wrench, 5-mm Allen Wrench

Remove the belt tensioner and bracket. Refer to Procedure 008-087.



10 mm

Remove the fan hub assembly. Refer to Procedure 008-036.

**NOTE:** Omit this step if the fan bracket is **not** attached to the cylinder head.

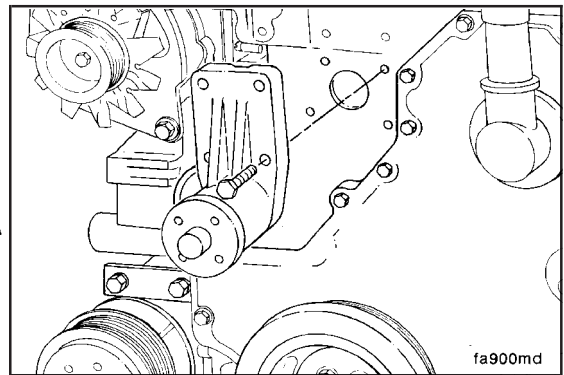

10 mm

Loosen the alternator link, mounting bolt, and water inlet connection capscrews.

Remove the alternator bracket mounting capscrews, and pivot the alternator away from the engine. Refer to Procedure 013-003.

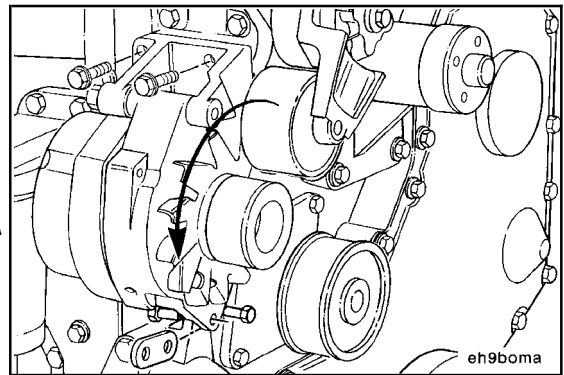

10 mm

Remove the thermostat housing assembly and bracket from the engine. Refer to Procedure 008-013.

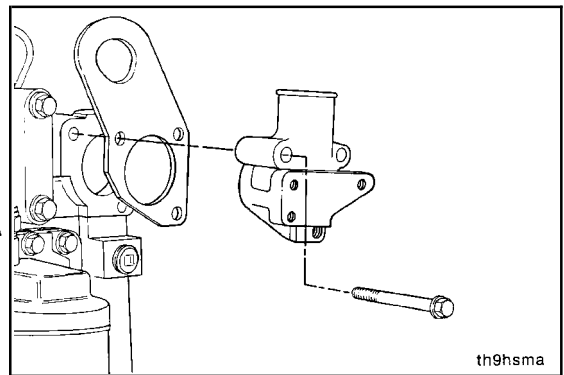

**Remove (002-004-002)**

18 mm

Remove the cylinder head capscrews in the sequence shown.

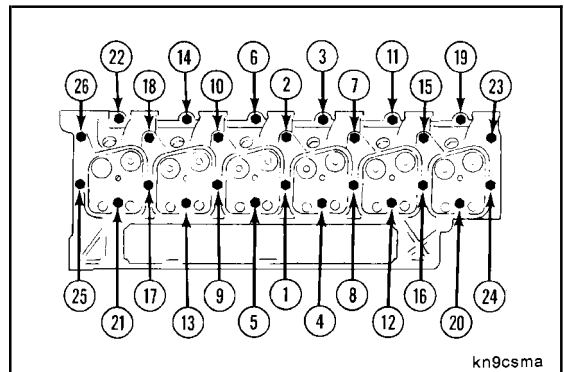

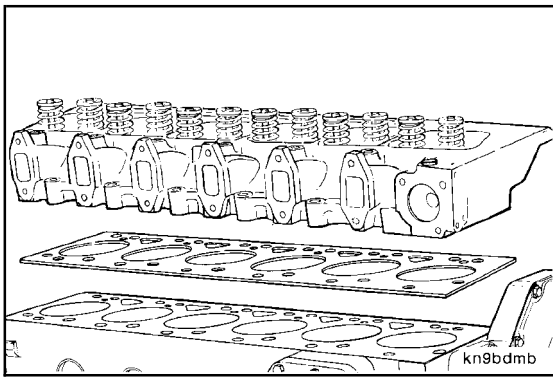

**▲ WARNING ▲**

The component weighs 23 kg [51 lb] or more. To avoid personal injury, use a hoist or get assistance to lift the component.



**▲ CAUTION ▲**

Do not lay the cylinder head on the combustion deck. This can cause damage to the cylinder head deck.

Remove the cylinder head and gasket from the cylinder block. Be sure the head is removed in a direct upward direction.

**Cylinder Head Weight**

Cylinder No.	Kg	lb
4	36	79
6	51.3	113

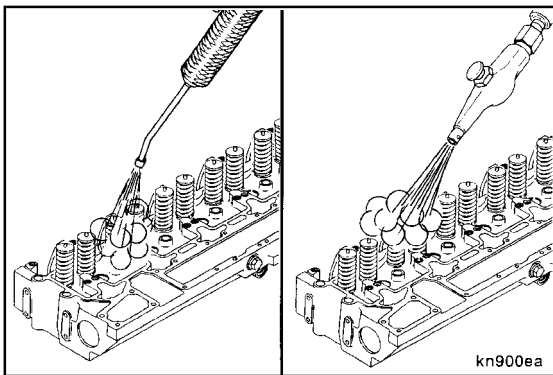

**Clean (002-004-006)**

**▲ WARNING ▲**

When using a steam cleaner, wear safety glasses or a face shield, as well as protective clothing. Hot steam can cause serious personal injury.

**▲ WARNING ▲**

Wear appropriate eye and face protection when using compressed air. Flying debris and dirt can cause bodily injury.

Steam-clean the cylinder head.

Dry with compressed air.

**NOTE:** Make sure to blow out all of the capscrew holes.

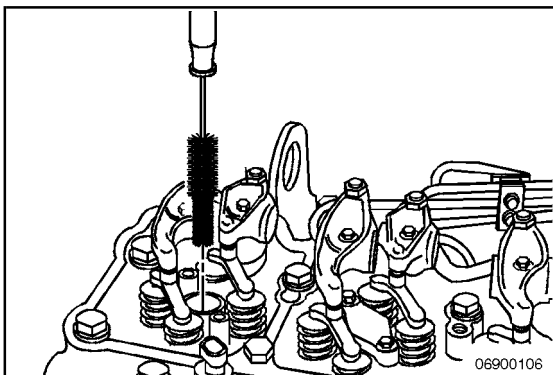

**Injector Bore Brush, Part No. 3822509**

Clean the carbon from the injector nozzle seat.



Disassemble the cylinder head. Refer to Procedure 002-020.

Scrape the gasket material from all gasket surfaces on the block and head.

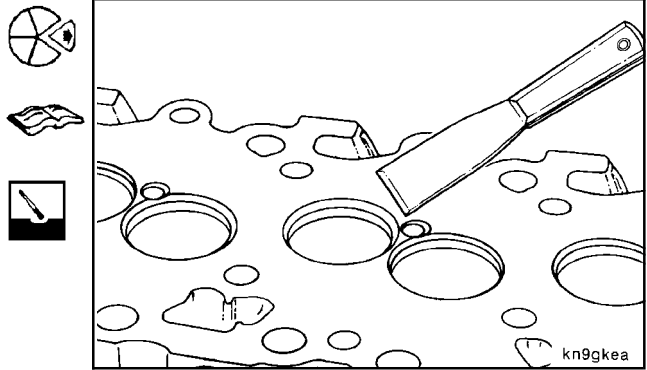

**⚠ WARNING ⚠**

**When using solvents, acids, or alkaline materials for cleaning, follow the manufacturer's recommendations for use. Wear goggles and protective clothing to avoid personal injury.**

Clean the buildup of deposits from the coolant passages. Excessive deposits can be cleaned in an acid tank, but the expansion plugs **must** first be removed.

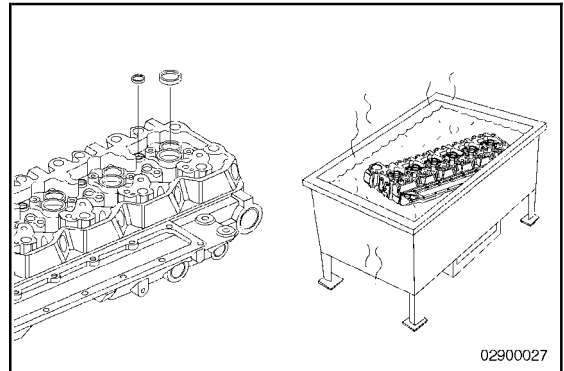

**⚠ WARNING ⚠**

**Do not mix gasoline, alcohol, or gasohol with diesel fuel. This mixture can cause an explosion.**

**⚠ WARNING ⚠**

**When using solvents, acids, or alkaline materials for cleaning, follow the manufacturer's recommendations for use. Wear goggles and protective clothing to avoid personal injury.**

**⚠ WARNING ⚠**

**Use skin and eye protection when handling caustic solutions to avoid personal injury.**

Clean the cylinder head combustion deck with a Scotch-Brite™ pad, or an equivalent cleaning pad, and diesel fuel or solvent.

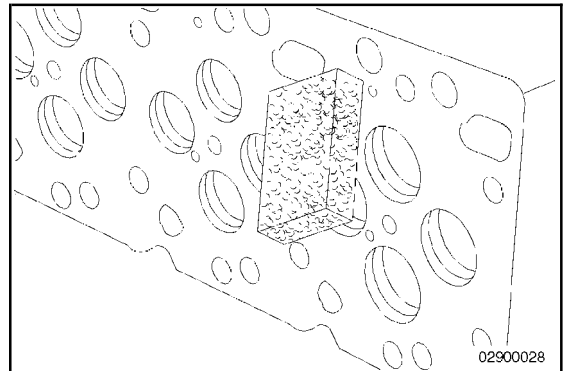

**⚠ WARNING ⚠**

**Wear protective eye covering while cleaning carbon deposits to prevent eye injury.**

Clean carbon deposits from the valve pockets with a high-quality steel wire wheel installed in a drill or a die grinder.

**NOTE:** An inferior-quality wire wheel will loosen steel bristles during operation, thus causing additional contamination.

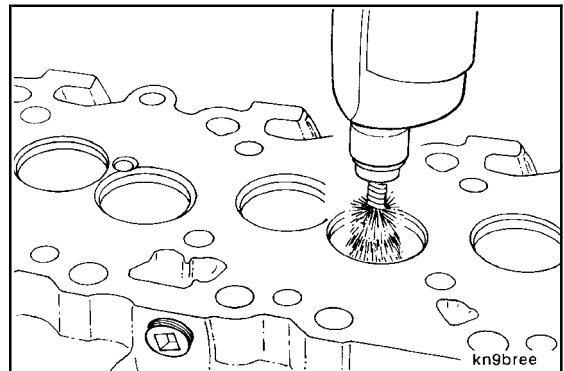

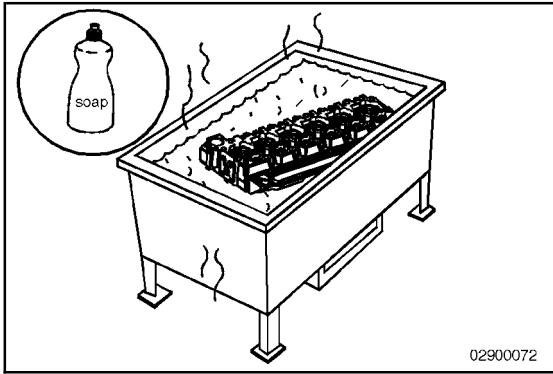

02900072



**⚠ WARNING ⚠**

Wear appropriate eye and face protection when using compressed air. Flying debris and dirt can cause bodily injury.

Wash the cylinder head in hot, soapy water solution.

After rinsing, use compressed air to dry the cylinder head.

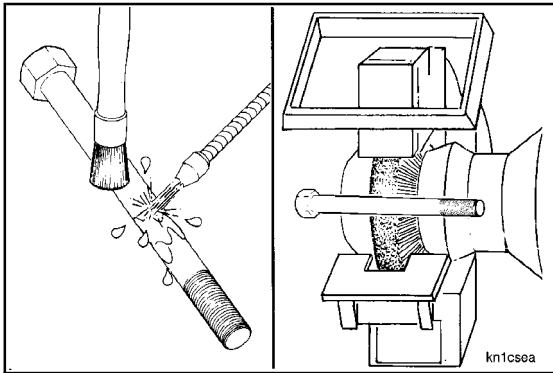

kn1csea



**⚠ WARNING ⚠**

Use skin and eye protection when handling caustic solutions to avoid personal injury.

**⚠ CAUTION ⚠**

Do not use caustic or acidic solutions to clean the cylinder head capscrews. Use of these solutions can cause corrosion.

Use a petroleum-based solvent to clean the capscrews.

Clean the cap screw thoroughly with a wire brush or a soft wire wheel, or use a nonabrasive bead blast to remove deposits from the shank and the threads.

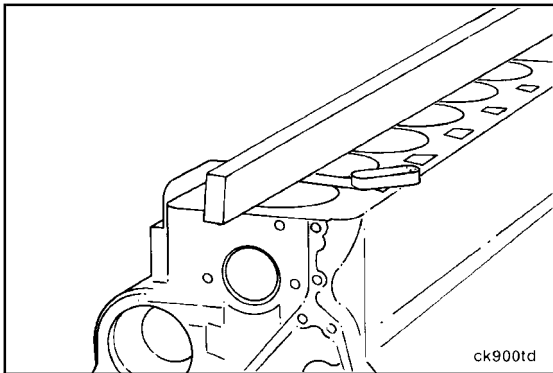

ck900td



**Inspect for Reuse (002-004-007)**

**Straightedge and Feeler Gauge**

**Cylinder Block Combustion Deck Inspect**



Use a straightedge and feeler gauge to measure the overall flatness of the cylinder block. The overall flatness, end-to-end and side-to-side, **must not** exceed 0.075 mm [0.003 in].



Inspect the combustion deck for any localized dips or imperfections. If present, the cylinder block head deck **must** be ground.

Refer to the Alternate Repair Manual, Bulletin No. 3666109, for grinding/milling procedures and limitations.

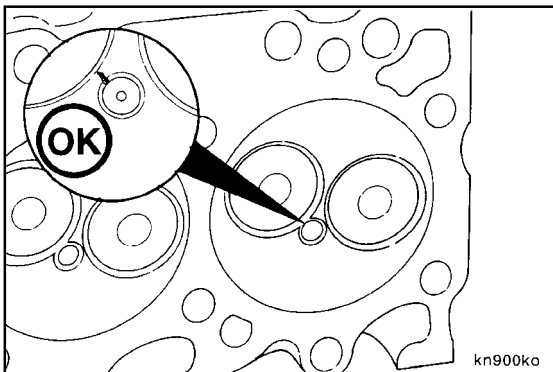

kn900ko



**Cylinder Head Cracks - Reuse Guidelines**

The reuse guidelines for a cylinder head with a crack extending from the injector bore to the valve seat are as follows:

If the crack does **not** extend into the valve seat, the cylinder head is reusable.

**B3.9 and B5.9 Series Engines**  
**Section 2 - Cylinder Head - Group 02**

If the crack extends into or through the valve seat, the cylinder head **must** be repaired by installing a valve seat insert according to the Alternative Repair Manual, Bulletin No. 3810234.

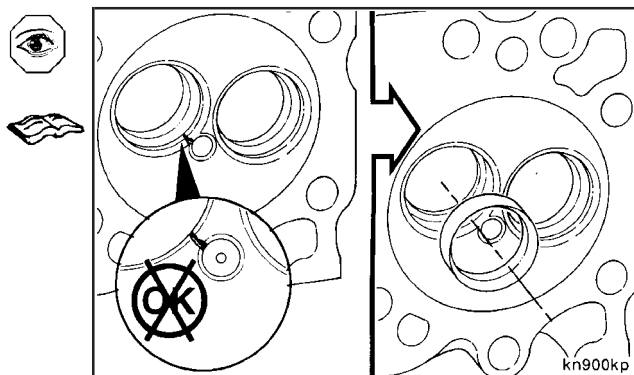

These guidelines apply **only** to cracks extending from the exhaust valve seat to the **intake** valve seats. Replace cylinder heads that exhibit valve bridge cracks in any other location.

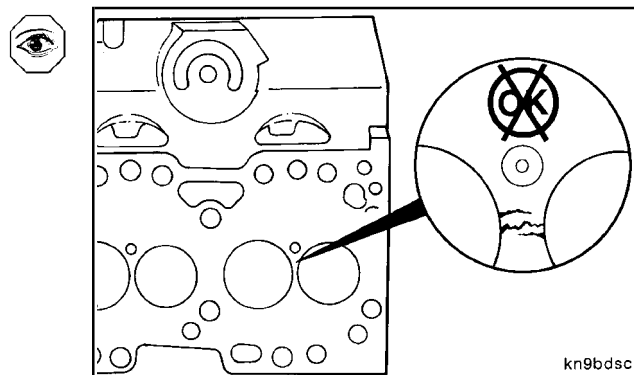

Inspect valves for indications of leakage or burning.

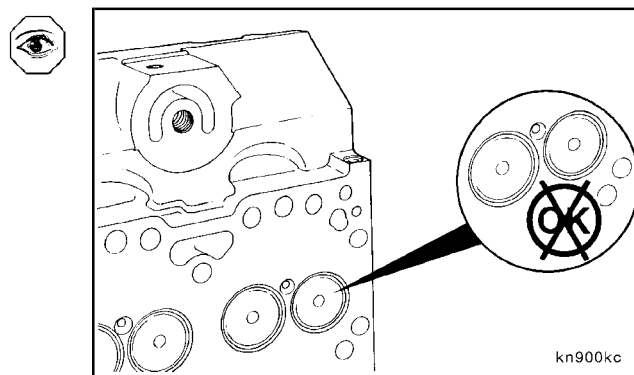

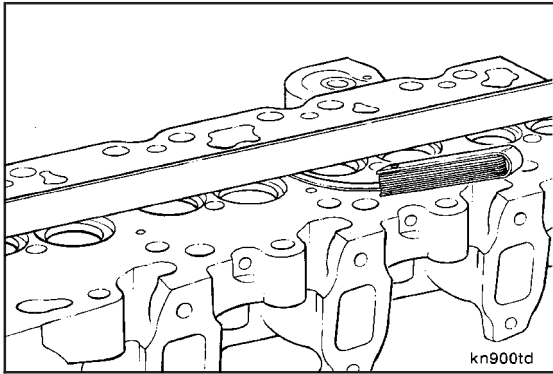

Use a straightedge and a feeler gauge to inspect the cylinder head combustion surface for flatness.

**Cylinder Head Flatness (6B engine)**

	mm		in
End-to-End	0.305	MAX	0.012
Side-to-Side	0.076	MAX	0.003

**Cylinder Head Flatness (4B engine)**

	mm		in
End-to-End	0.203	MAX	0.008
Side-to-Side	0.305	MAX	0.012

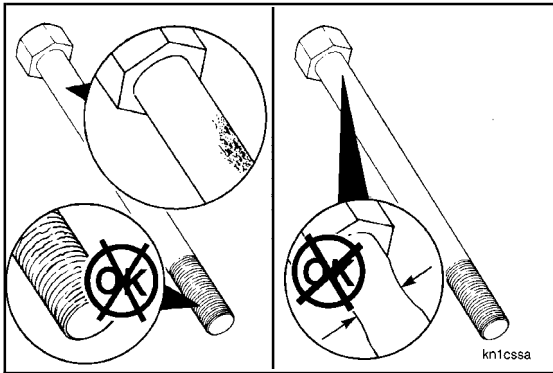

**Cylinder Head Capscrews**

Inspect the cylinder head capscrews for damaged threads, corroded surfaces, or a reduced diameter (due to capscrew stretching).

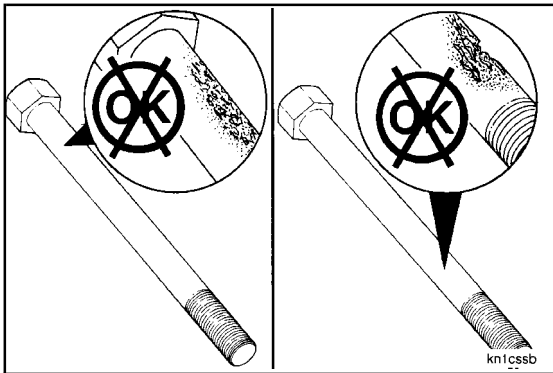

Do **not** reuse cylinder head capscrews under the following conditions:

- Visible corrosion or pitting exceeds 1 sq cm [0.155 sq. in] in area
- Acceptable 3/8 x 3/8 inch
- Unacceptable 1/2 x 1/2 inch
- Visible corrosion or pitting exceeds 0.12 mm [0.005 in] in depth.

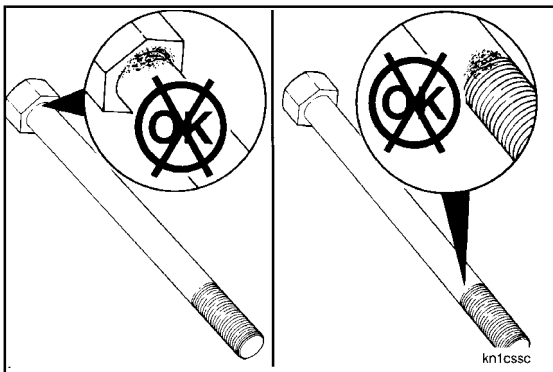

- Visible corrosion or pitting is located within 3.2 mm [1/8 in] of the fillet.
- Visible corrosion or pitting is located within 3.2 mm [1/8 in] of the threads.
- Stretched beyond “free-length” maximum. Refer to the measurement procedure below:



Capscrew Length Gauge, Part No. 3823921

Free-Length Measurement

**NOTE:** If the capscrews are **not** damaged, they can be reused throughout the life of the engine unless the specified "free length" is exceeded.

To check the capscrew free length, place the head of the capscrew in the appropriate slot with the flange against the base of the slot.

Capscrew Free Length			
	mm		in
Short	71.5	MAX	2.815
Medium	122.1	MAX	4.807
Long	182.9	MAX	7.201

If the end of the capscrew touches the foot of the gauge, the capscrew is too long and **must** be discarded.

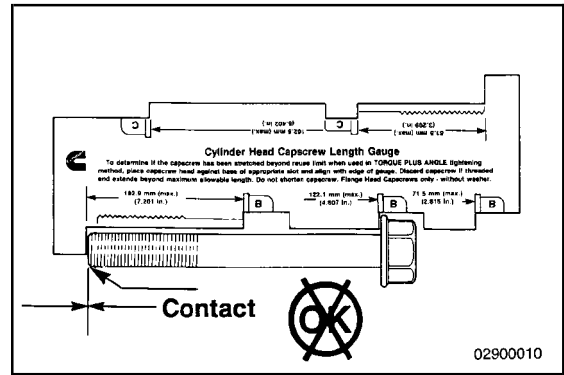
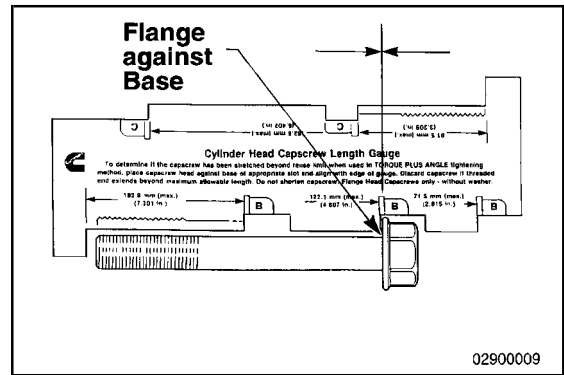

Immediately after cleaning and inspecting the capscrew. Apply a film of clean engine oil to all capscrews that are to be reused.

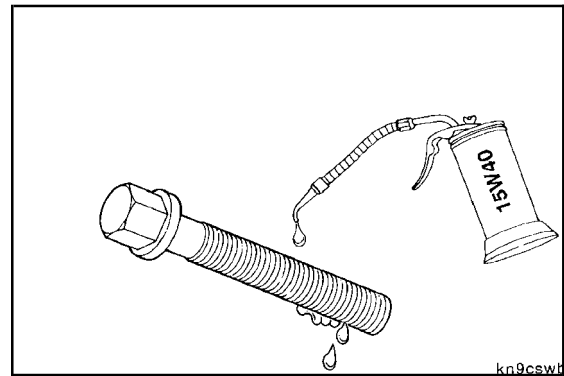

Install (002-004-026)



**Be sure the gasket is correctly aligned with holes in the cylinder block. If the gasket is not aligned correctly engine damage can result.**

Position a new cylinder head gasket over the dowels.

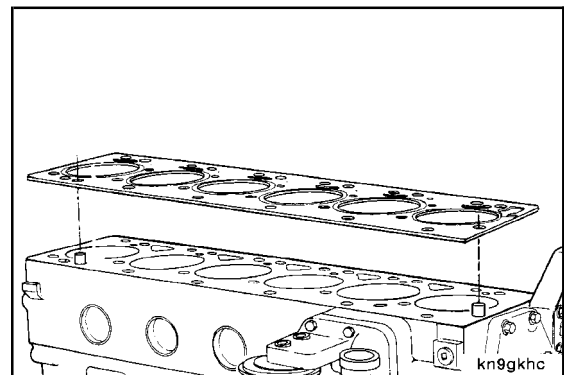

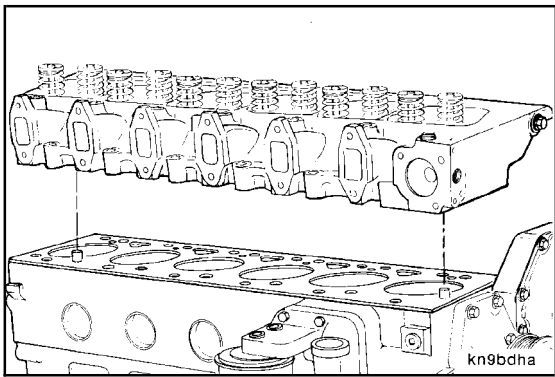

**▲ WARNING ▲**

The component weighs 23 kg [51 lb] or more. To avoid personal injury, use a hoist or get assistance to lift the component.



Carefully put the cylinder head straight down onto the cylinder block, and seat it onto the dowels.

**Cylinder Head Weight**

Cylinder No.	Kg	lb
4	36	79
6	51.3	113

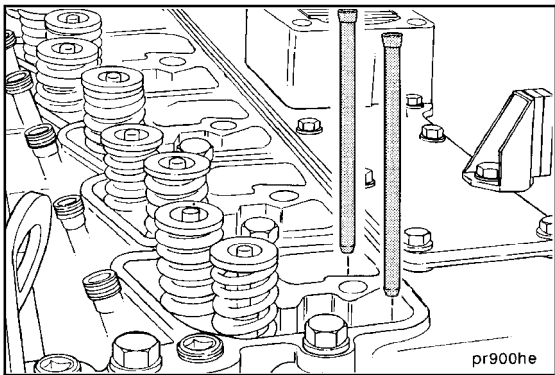

**Push Tubes - Installation**

Position the push tubes into the valve tappets.

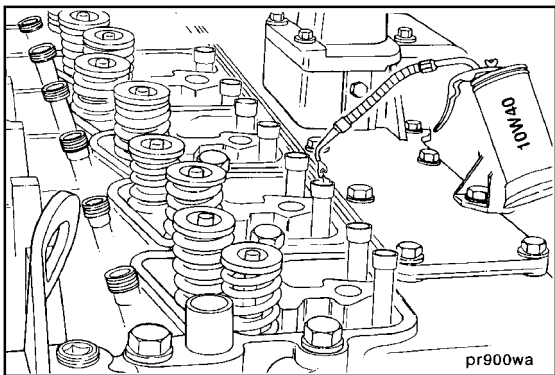

Lubricate the push tube sockets with clean lubricating engine oil.

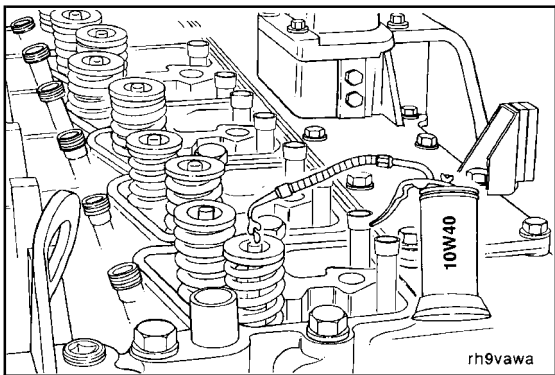

**Rocker Levers - Installation**

Lubricate the valve stems with clean lubricating engine oil.

**14-mm Flat-Blade Screwdriver**

Completely loosen the rocker lever adjusting screws.

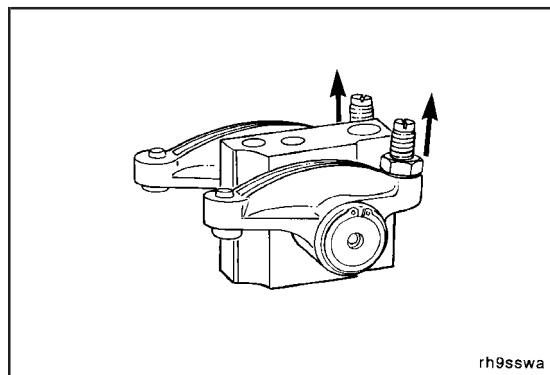

rh9sswa

**NOTE:** The rocker lever pedestals are aligned with dowels.  
 Install the pedestals.

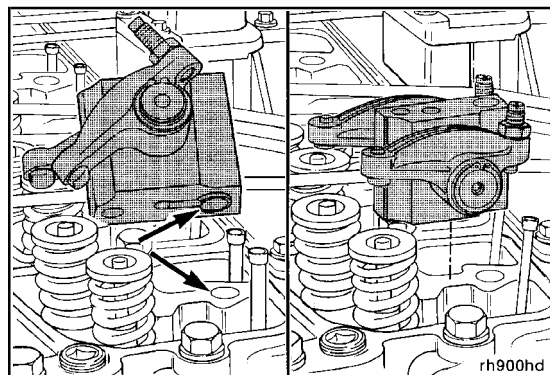

rh900hd

**Capscrew Length Gauge, Part No. 3823921**

Inspect all cylinder head capscrews for proper length using Service Tool No. 3823921.

Lubricate the **8-mm** pedestal capscrew threads and under the capscrew heads with clean lubricating engine oil.

Install the capscrews finger-tight.

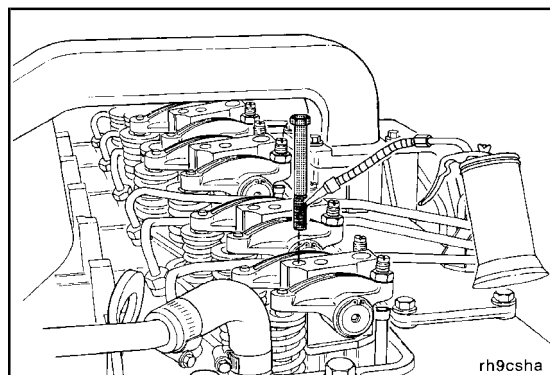

rh9csha

**Capscrew Length Gauge, Part No. 3823921**

Inspect all cylinder head capscrews for proper length using Service Tool No. 3823921.

Lubricate the **12-mm** pedestal/head capscrew bolt threads and under the capscrew heads with clean lubricating engine oil.

Install the capscrews finger tight.

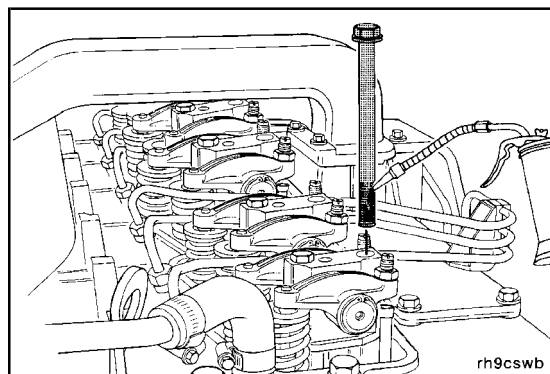

rh9cswb

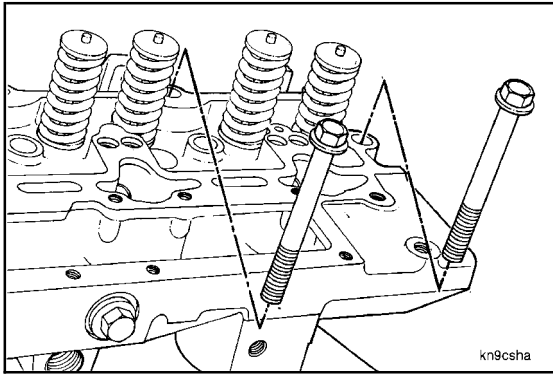

Lubricate the threads and under the heads on the remaining cylinder head capscrews with clean lubricating engine oil.



Install capscrews in the cylinder head and finger-tighten.

**NOTE:** Be sure to install the six capscrews into the holes underneath the injectors.

**NOTE:** Capscrews for the 1991 and later certification level engines are the same overall length, but have a longer threaded area.

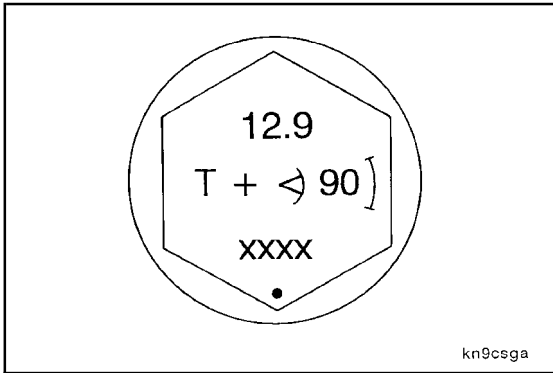

**CAUTION**

Do not use pre-1991 certification level engine capscrews in a 1991 B Series or later certification level engine because pre-1991 capscrews do not have enough threads to provide enough thread engagement in the 1991 and later certification engines. Failure to do so can result in engine damage.

**CAUTION**

Capscrews for a 1991 B Series or later certification level engine can be used in a pre-1991 certification level engine because 1991 and later capscrews have enough threads to provide enough engagement in all certification level engines.

**NOTE:** The top of the cylinder head capscrew is identified with an angle marking. The cylinder head capscrews **must** be tightened by using the three-step “torque plus angle” method described as follows.

Lubricate the threads and under side of the capscrew head of the cylinder head capscrews with clean lubricating engine oil.

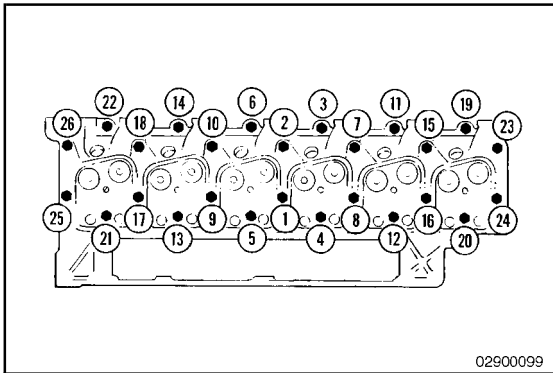

**Step 1**

1. Follow the numbered sequence, and tighten all 26 capscrews.

**Torque Value:** (Step 1) 90 N•m [66 ft-lb]

**Step 2**

2. Follow the numbered sequence, and tighten the six long capscrews **only** (No. 4, 5, 12, 13, 20, and 21).

**Torque Value:** (Step 2) 120 N•m [89 ft-lb]

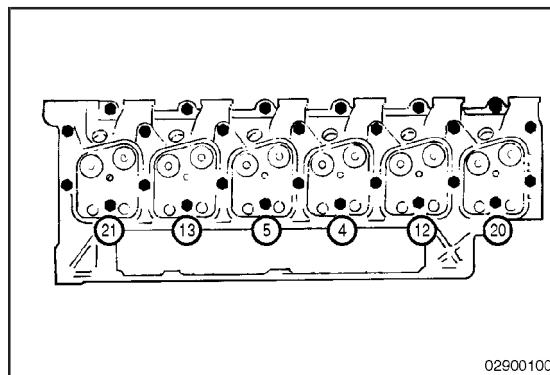

02900100

**Step 3**

3. Retighten the short capscrews (No. 1, 2, 3, 6, 7, 8, 9, 10, 11, 14, 15, 16, 17, 18, 19, 22, 23, 24, 25, and 26) because of cylinder head relaxation and to obtain proper cylinder head torque requirements.

**Torque Value:** (Step 1) 90 N•m [66 ft-lb]

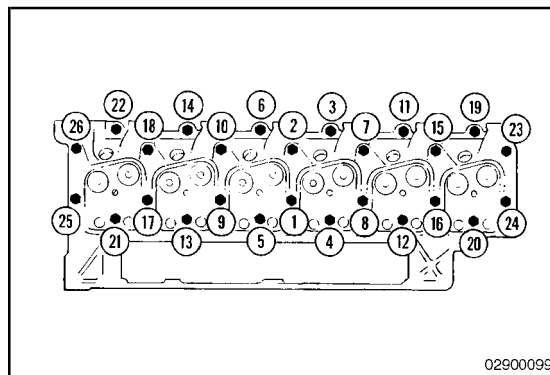

02900099

**Step 4**

4. Repeat step 2 because of cylinder head relaxation and to obtain proper cylinder head torque requirements.

**Torque Value:** (Step 2) 120 N•m [89 ft-lb]

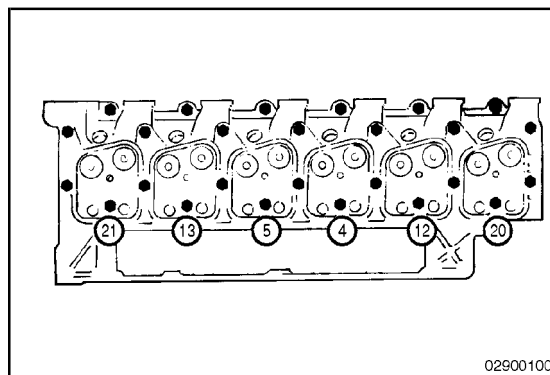

02900100

**Step 5**

- Follow the numbered sequence, and turn the capscrew 90 degrees as indicated on the capscrew head.

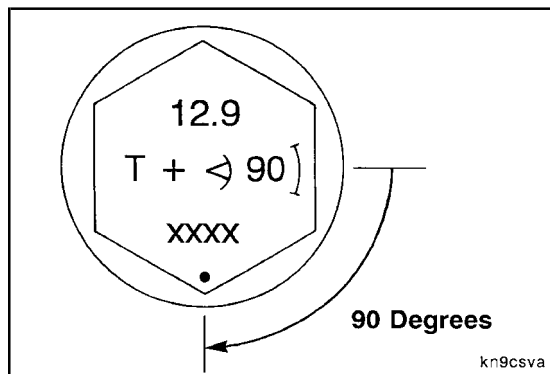

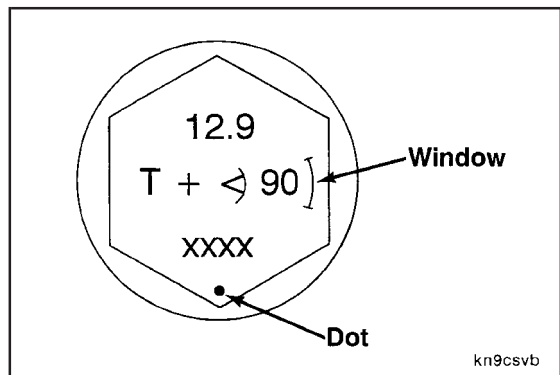

**Torque Angle Gauge - 3/4-Inch Drive, Part No. 3823878**

To turn the capscrew to the desired angle accurately, align the capscrew with the small "dot" and "window" that are marked on the capscrew head or use recommended service tool, Part No. 3823878, torque angle gauge for 3/4-inch drive.

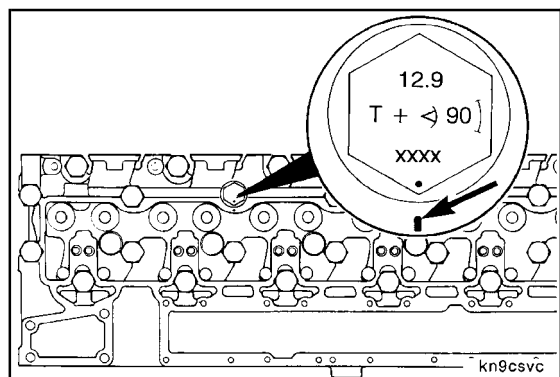

Mark the cylinder head adjacent to the dot on the capscrew head. This mark will serve as an indexing aid.

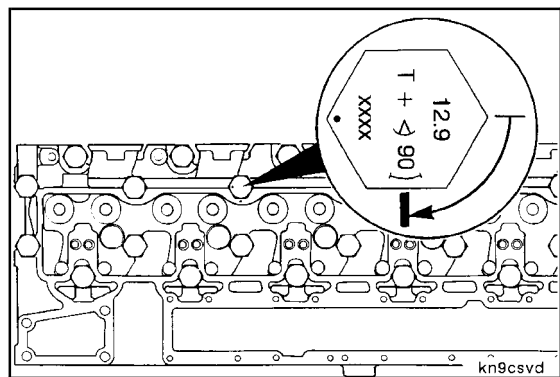

Rotate the capscrew until the mark that has been made on the cylinder head falls into the window on the capscrew head.

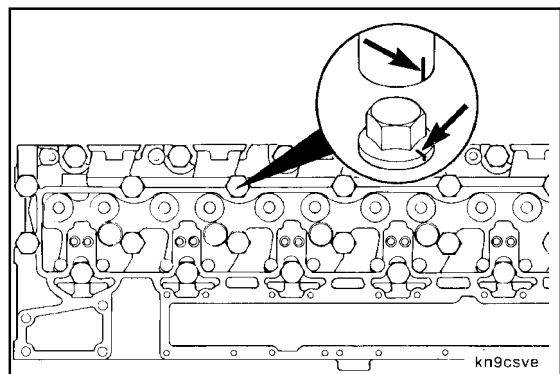

**Service Tip:**

Use a permanent marker to mark the socket corresponding to one of the flats of the socket hex.

After the torque has been applied, mark the cylinder head at the location of the dot.

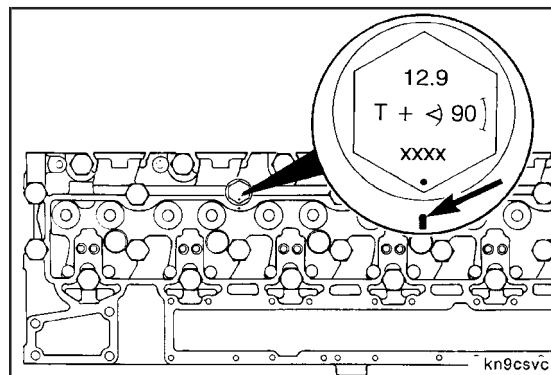

Position the socket on the capscrew such that the mark on the socket is at the same point as the window on the capscrew.

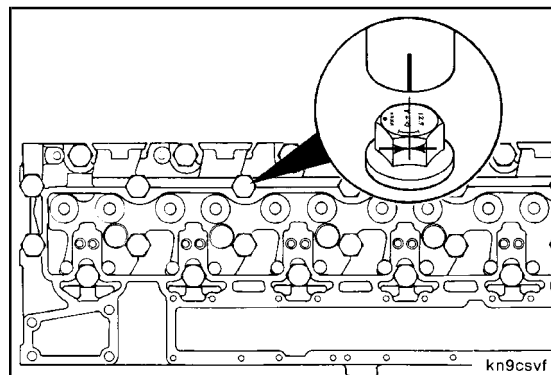

Turn the socket until the mark on the socket aligns with the mark on the cylinder head.

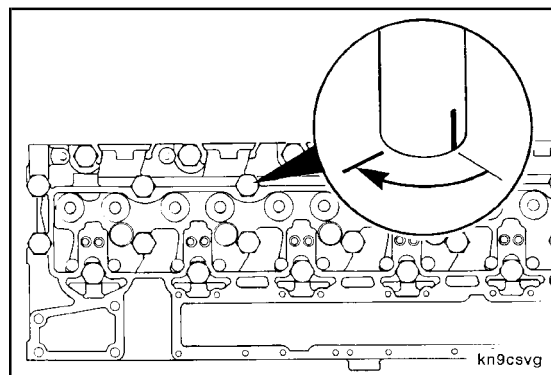

**8 mm**

Tighten the 8-mm pedestal capscrews.

**Torque Value:** 24 N•m [18 ft-lb]

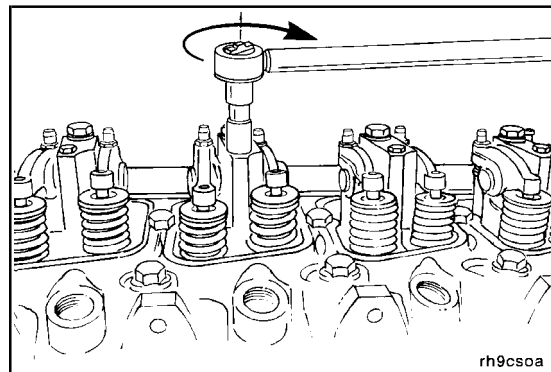

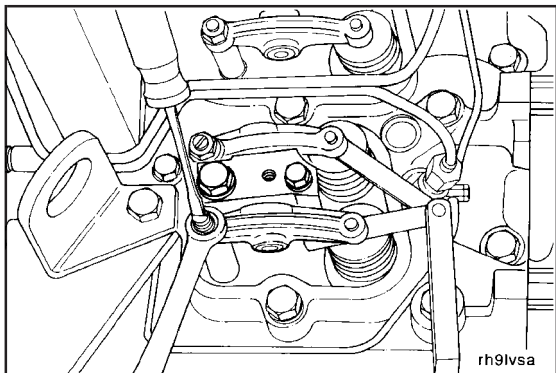

**Valve Clearance - Adjustment**

Adjust the valve clearance. Refer to Procedure 003-004.

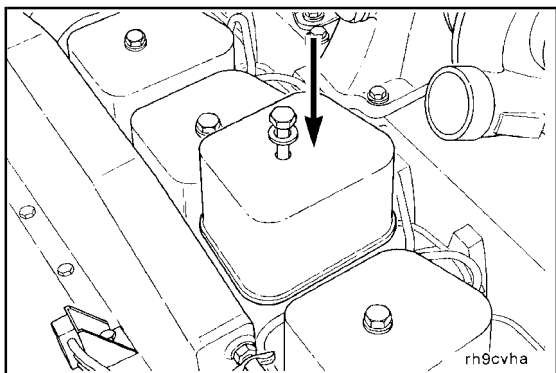

**15 mm**

Install the rocker lever cover(s). Refer to Procedure 003-011.



Tighten the capscrews.

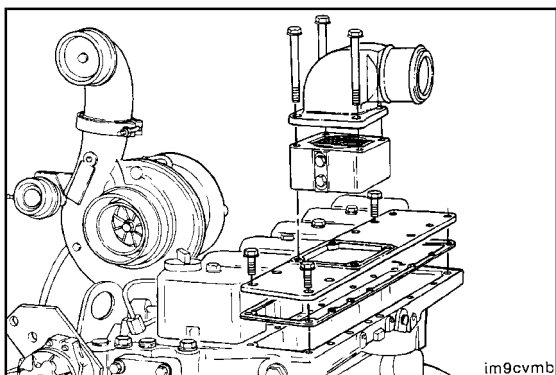

**10 mm**

Install the manifold cover plate. Refer to Procedure 010-023.



Install the fuel filter head to the air intake manifold.

Install intake heater (if equipped). Refer to Procedure 010-072.



Use the illustrated capscrews to secure the cover plate. The remaining holes are used to secure fuel line brackets.

**Torque Value:** 24 N•m [18 ft-lb]

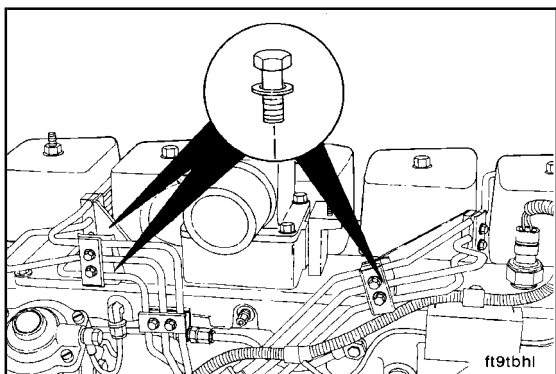

Install the injectors and fuel lines. Refer to Procedures 006-026 and 006-051.





Install the exhaust manifold and turbocharger. Refer to Procedures 011-007 and 010-033.

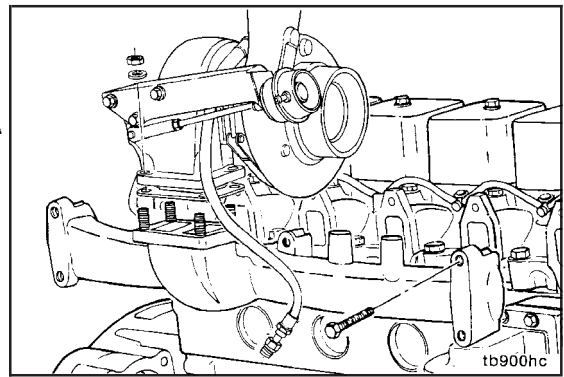

Install the thermostat and thermostat housing. Refer to Procedures 008-013 and 008-014.

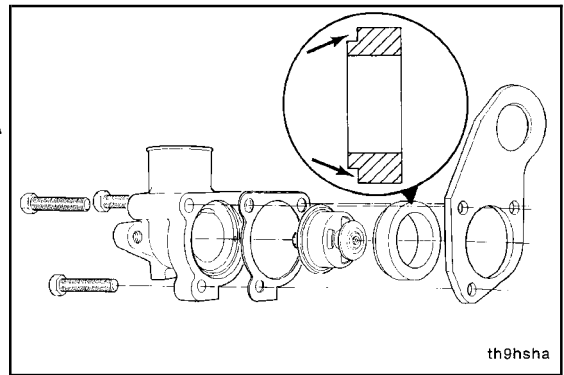

**10 mm**

Install the fan hub and fan pulley if equipped. Refer to Procedures 008-036 and 008-039.

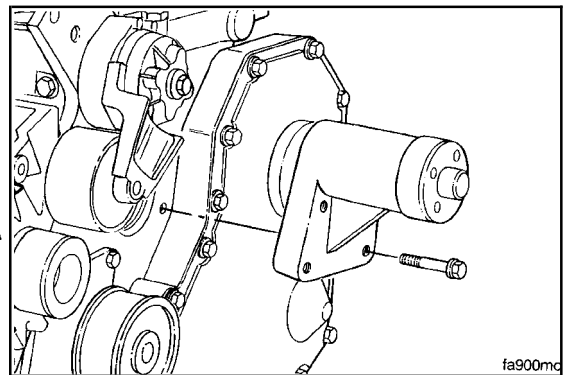

Install the belt tensioner and bracket. Refer to Procedure 008-087.

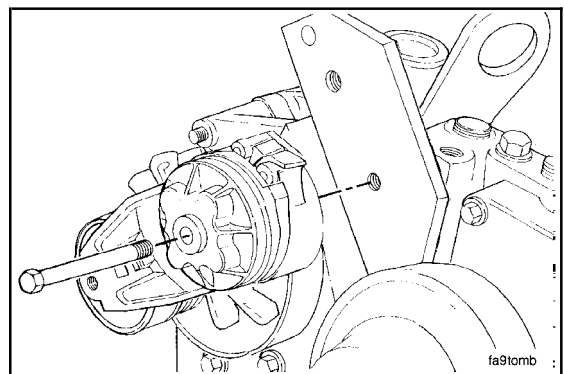

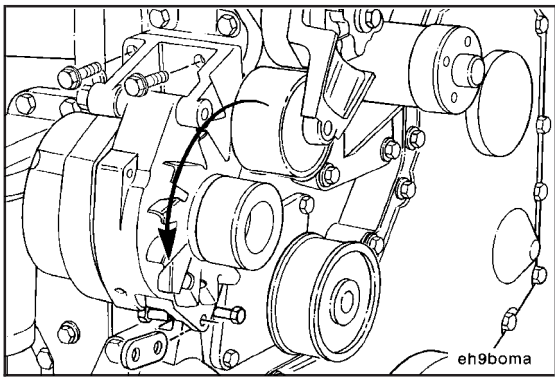

Install alternator and alternator bracket. Refer to Procedures 013-003 and 013-001.

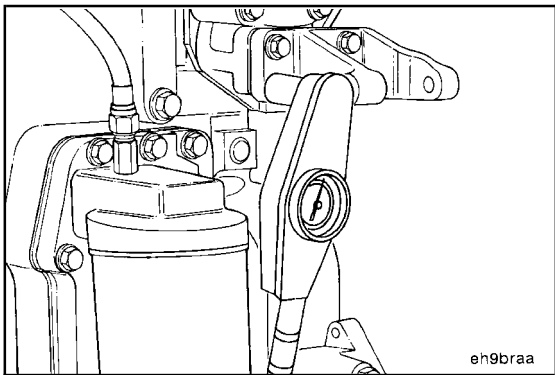

10 mm

Assemble the alternator bracket to the thermostat housing. Refer to Procedure 013-003.



**Torque Value:** 24 N•m [18 ft-lb]

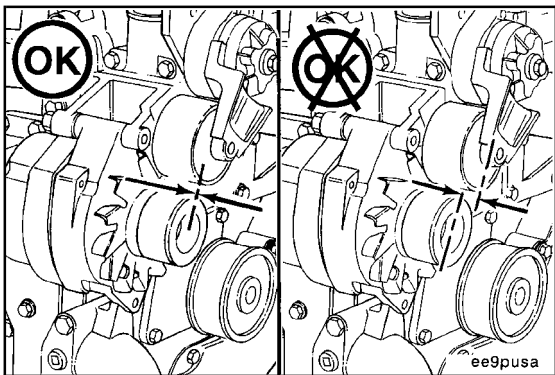

Check the alternator pulley alignment. Use a straightedge to make sure it is aligned with the other pulleys and is parallel to the front face of the block.

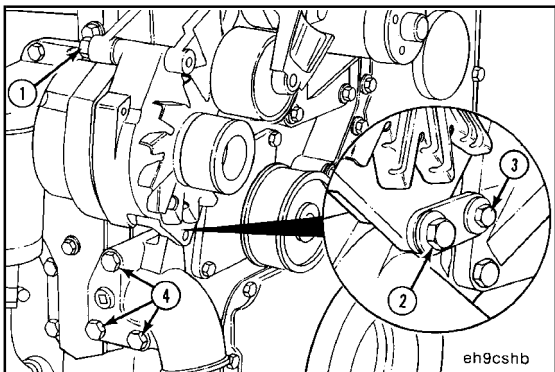

Tighten all capscrews in the following sequence:

1. Alternator-to-alternator bracket capscrew
2. Lower brace-to-alternator capscrew
3. Alternator-to-water inlet capscrew
4. Water inlet-to-block capscrews.



**NOTE:** Wrench size and torque value is determined by the make and model of alternator. Refer to the Engine Component Torque Values.

**Engine Noise Diagnostic Procedures -  
General Information (002-004-331)**

**Engine Noise Diagnostics**

The sound emitted from the overhead can indicate a valve train problem. Loose rocker levers will clatter. A squeaking noise can mean lack of lubrication for the adjusting screw and the pushrod socket.

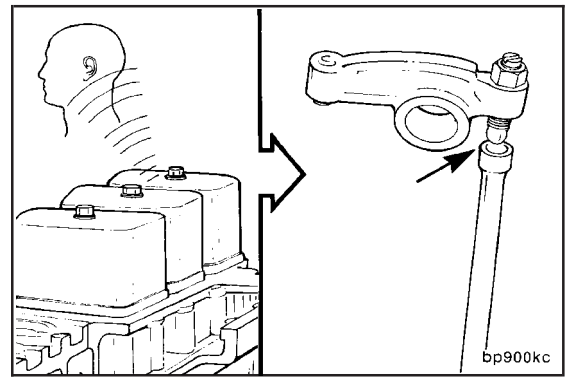

Valve leakage is often audible from the intake and exhaust manifolds.

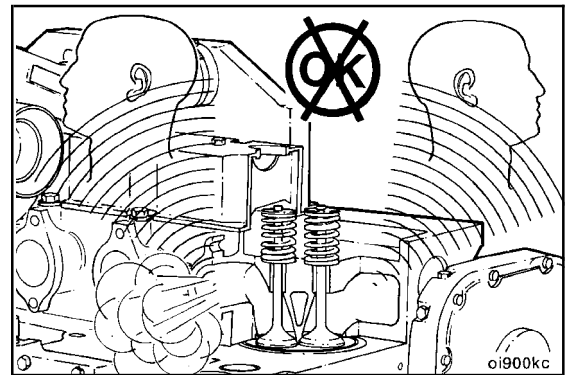

**Valve Sealing**

If the compression is low on one or more nonadjacent cylinders and the pressure can **not** be increased by oiling the rings, improper valve sealing is to be suspected.

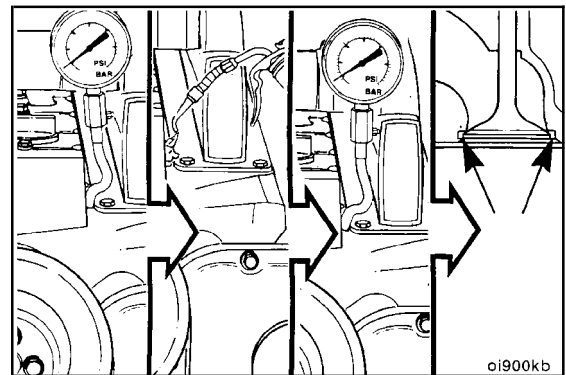

**Valve Guide Seal, Cylinder Head  
(002-016)**

**Initial Check (002-016-001)**

**Valve Seal - Wear**

Worn valve seals are typically detected by excessive smoke at idle or when the engine is unloaded when the vehicle is going downhill. Verify the condition by removing the valve spring and inspecting the valve seals.

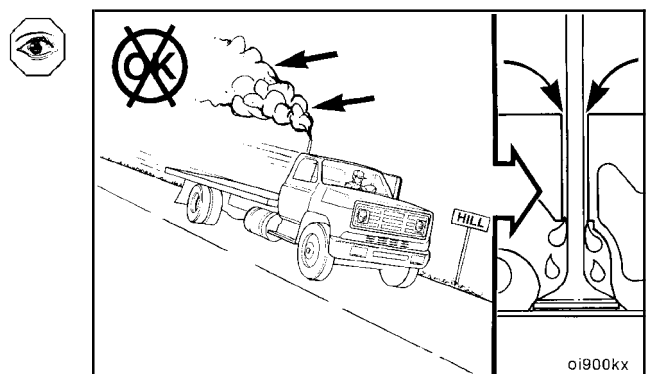

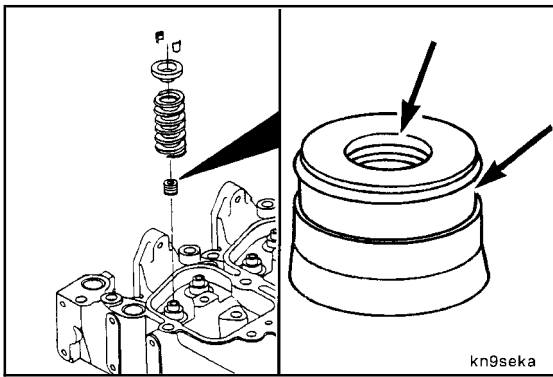

Hardening of the material and wear or damage to the sealing surfaces will cause the valve seal to leak.

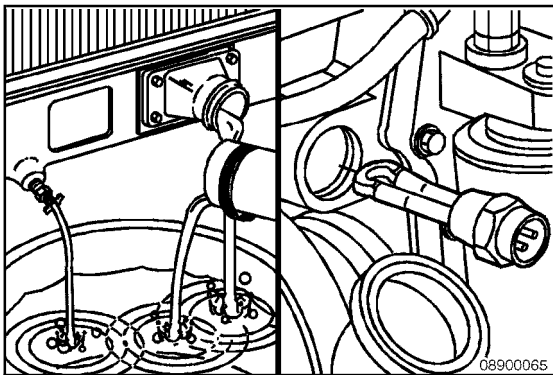

**Valve, Cylinder Head (002-020)**  
**Preparatory (002-020-000)**



**▲ WARNING ▲**

Coolant is toxic. Keep away from pets and children. If not reused, dispose of in accordance with local environmental regulations.

**▲ WARNING ▲**

Do not remove the pressure cap from a hot engine. Wait until the temperature is below 50°C [120°F] before removing the pressure cap. heated coolant spray or steam can cause personal injury.

- Drain the coolant. Refer to Procedure 008-018.
- Remove all water and heater hoses.
- Remove the cylinder head. Refer to Procedure 002-004.

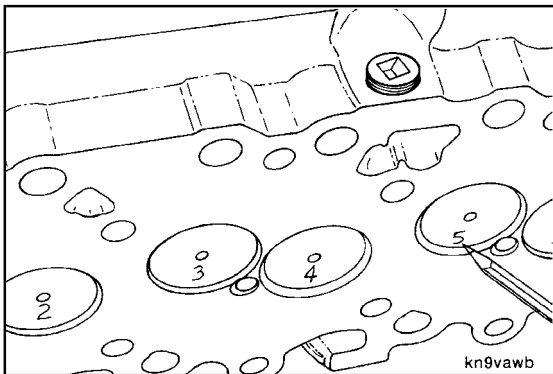

**Disassemble (002-020-003)**

Mark the valves to identify their location.

**Valve Spring Compressor, Part No. 3375962**

**NOTE:** If the valve springs, collets, retainers, and valve guide seals are to be used again, they **must** be installed in their original location.

Compress the valve spring using the valve spring compressor, Part No. 3375962, and remove the valve stem collets. Remove the collets.

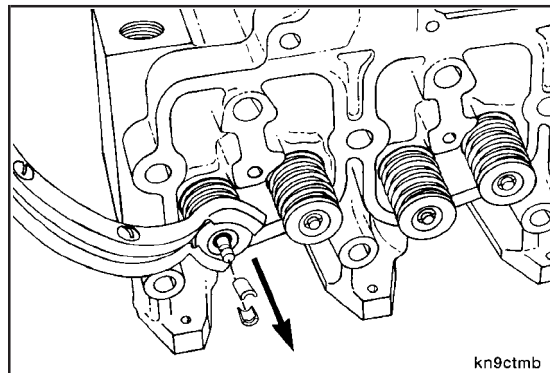

**3/8-Inch Square Drive**

Release valve spring and remove the spring retainer and spring.

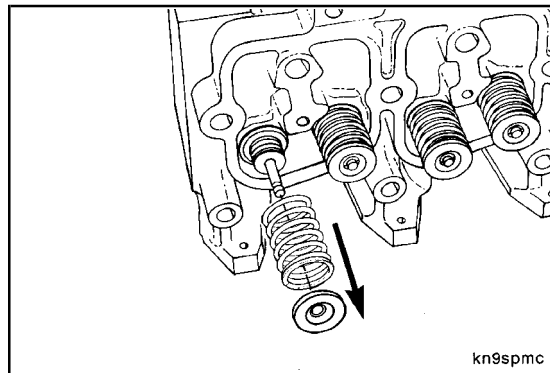

Remove the remaining collets, retainers, springs, and valves.

**NOTE:** Keep the valves in a labeled rack for a correct match with companion seats while making measurements.

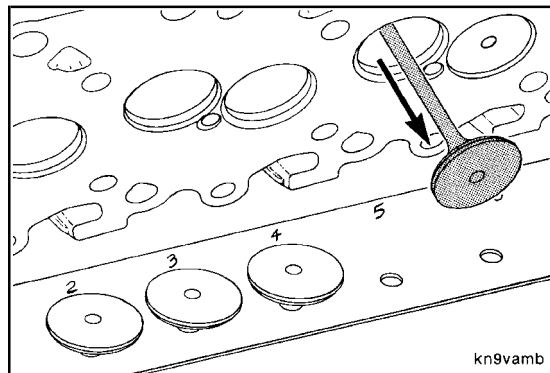

Remove the valve stem seals.

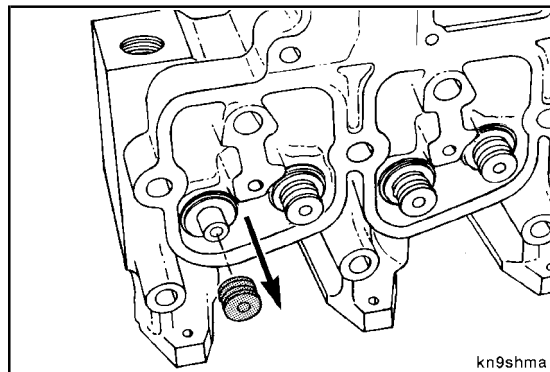

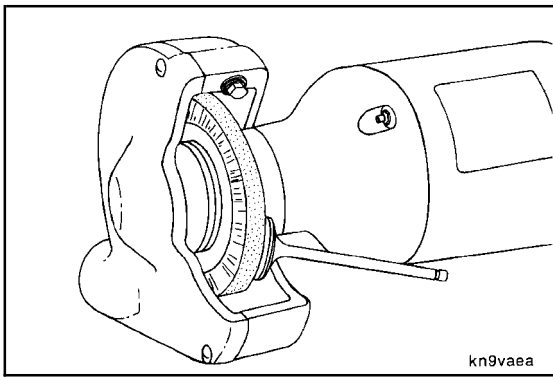

**Clean (002-020-006)**

**▲ WARNING ▲**

Wear protective eye covering when cleaning the valves. Failure to do so can cause injury to the eyes.

Clean the valve heads with a soft wire wheel.

**NOTE:** Keep the valves in a labeled rack to prevent mixing prior to making measurements.

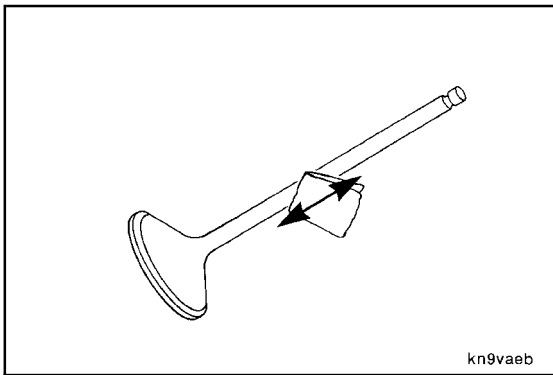

**▲ WARNING ▲**

Do not mix gasoline, alcohol, or gasohol with diesel fuel. This mixture can cause an explosion.

**▲ WARNING ▲**

When using solvents, acids, or alkaline materials for cleaning, follow the manufacturer's recommendations for use. Wear goggles and protective clothing to avoid personal injury.

**▲ WARNING ▲**

Use skin and eye protection when handling caustic solutions to avoid personal injury.

Polish the valve stem with a Scotch-Brite™ pad, or equivalent cleaning pad, and diesel fuel or solvent.

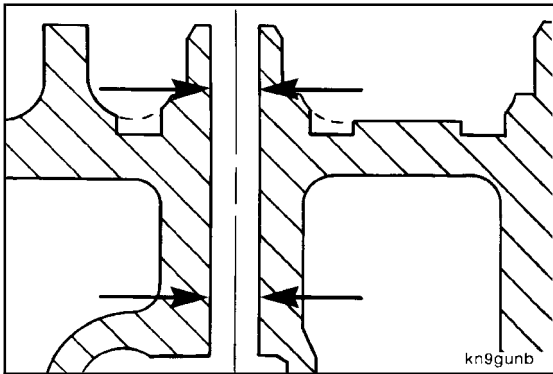

**Inspect for Reuse (002-020-007)**

**Valve Guide Inspection**

Inspect the valve guides for scuffing or scoring.

Measure the valve guide bore.



Valve Guide Bore Diameter		
mm		in
8.019	MIN	0.3157
8.090	MAX	0.3185

If the inspection reveals damaged valve guides, refer to the Alternative Repair Manual, Bulletin No. 3810234.

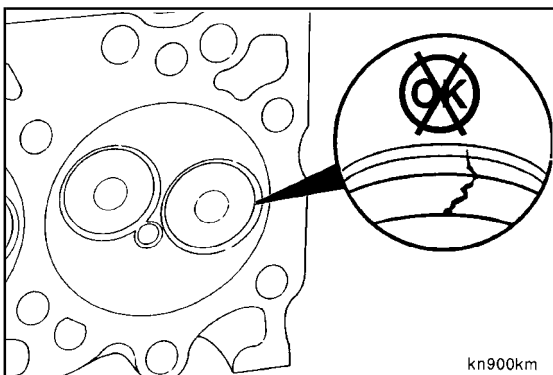

**Valve Seat Inspection**

Inspect the valve seats for cracks or burned spots.



Refer to the following reuse guidelines for any cracks discovered. Service valve seats are available for seats with burned spots that will require more than 0.254 mm [0.010 in] grinding to clean up. Refer to the Alternative Repair Manual, Bulletin No. 3810234, for valve seat installation procedures.

Inspect for abnormal wear on the heads and stems.

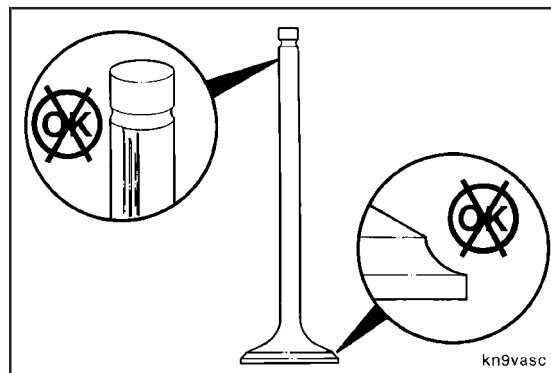

Measure the valve stem diameter.

Valve Stem Diameter		
mm		ft-lb
7.94	MIN	0.3126
7.98	MAX	0.3142

**NOTE:** If the valve is **not** within specification, it **must** be replaced.

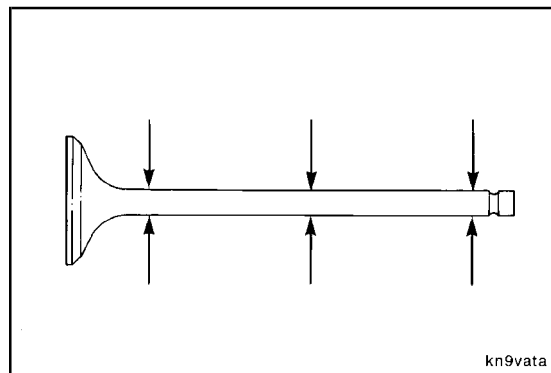

Check the valve stem tip for flatness.

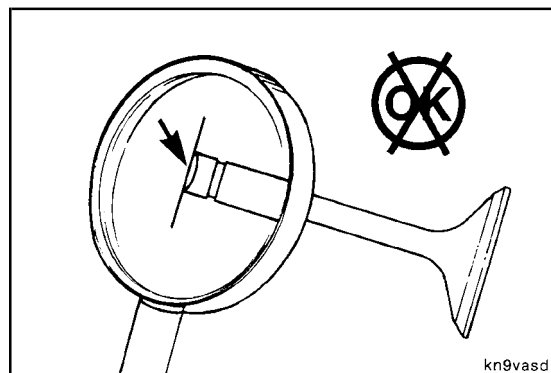

Inspect for bent valves.

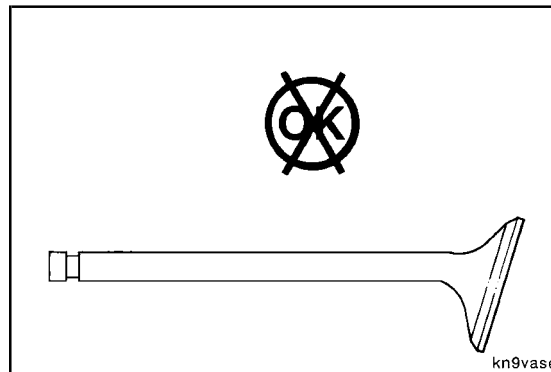

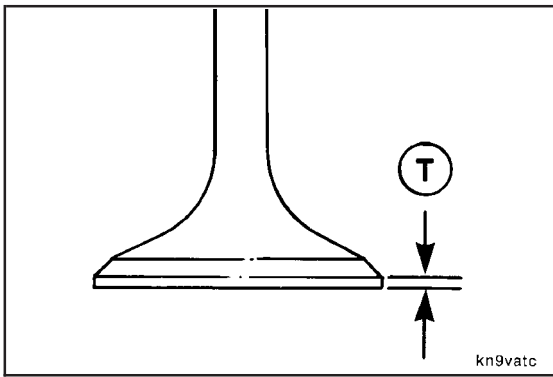

Measure the rim thickness to determine if there is enough stock to grind the valve.

**Valve Rim Thickness Limit**

mm		in
0.79	MIN	0.031

If the valves are determined to be suitable for resurfacing, refer to the B Series Shop Manual, Bulletin No. 3810206.

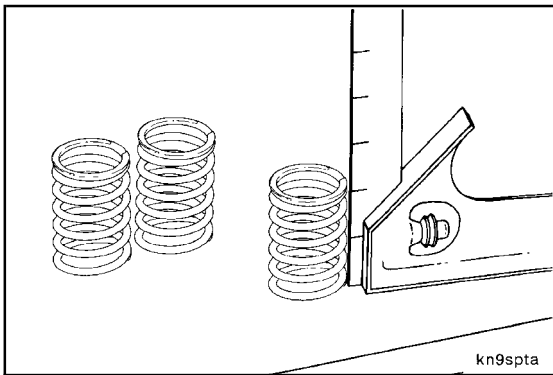

Inspect the valve springs.  
Measure the valve spring.



**Approx. Free Length (L):**

1991 55.63 mm [2.190 in]

**Maximum Inclination:**

1991 1.00 mm [0.039 in]

**Approx. Free Length (L):**

1994 60.00 mm [2.362 in]

**Maximum Inclination:**

1994 1.00 mm [0.039 in]

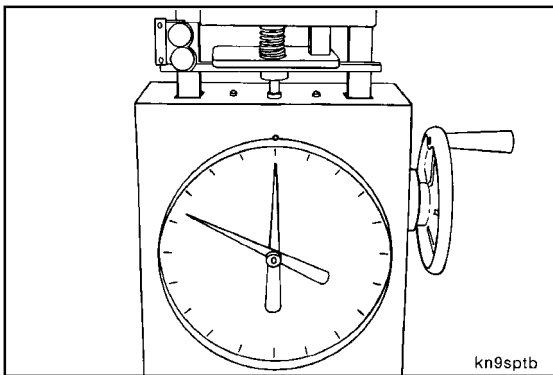

A load of 289.13 to 321.16 N [65.0 to 72.2 lb] (1991) and 359 to 397 N [80.7 to 89.2 lb] (1994) is required to compress the spring to a height of 49.25 mm [1.94 in].

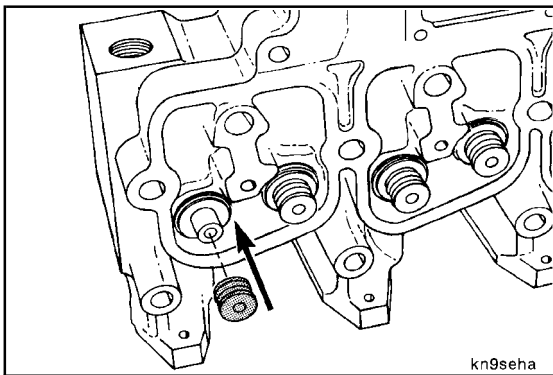

**Assemble (002-020-025)**

**NOTE:** Clean all cylinder head components before assembling.



Install new valve stem seals.

The intake and exhaust seals are the same.



**B3.9 and B5.9 Series Engines**  
**Section 2 - Cylinder Head - Group 02**

Lubricate the stems with SAE 90W engine oil before installing the valves.

Install valves into their original location.

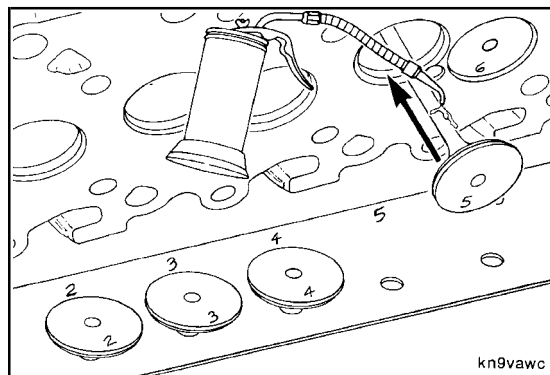

**Valve Spring Compressor, Part No. 3375962**

Install the valve spring and retainer.

Use the valve spring compressor, Part No. 3375962, to compress the valve spring and retainer assembly.

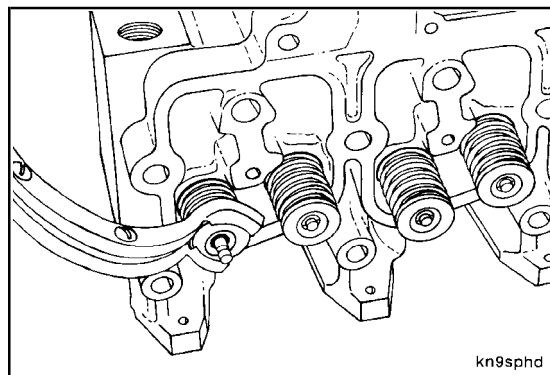

Install new valve collets and release the spring tension.

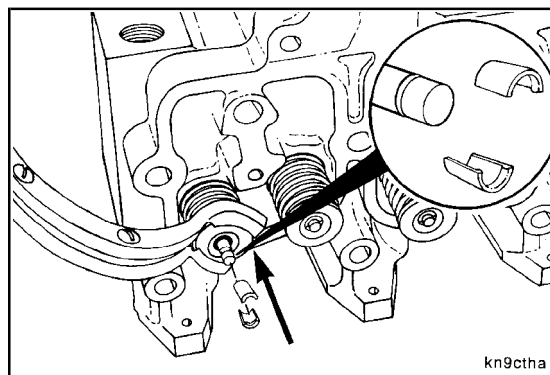

**▲ WARNING ▲**

**Wear eye protection. If the collets are not correctly installed, they can fly out when the stems are hit with a hammer.**

**Plastic Hammer**

After assembly, hit the valve stems with a plastic hammer to make sure that the collets are seated.

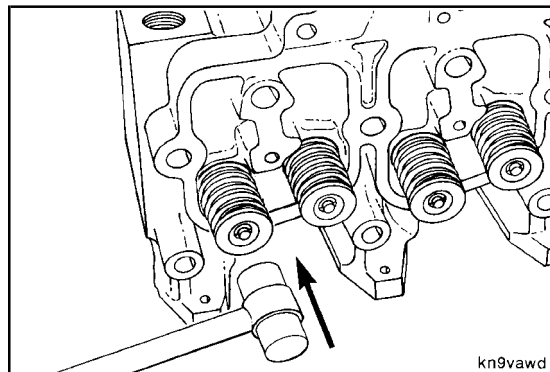

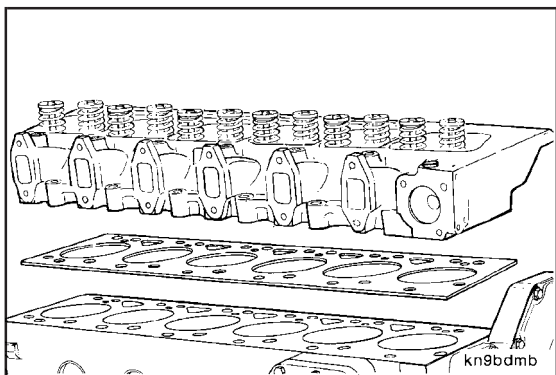

**Install (002-020-026)**

Install the cylinder head and gasket. Refer to Procedure 002-004.

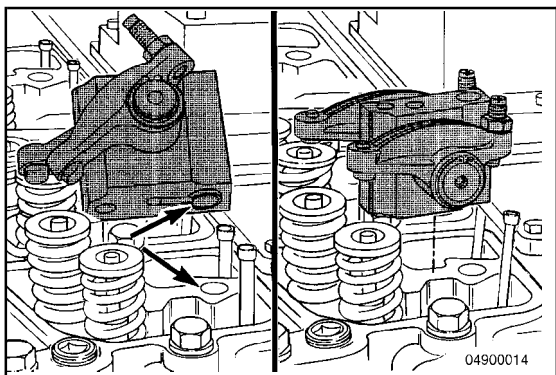

Install the rocker levers. Refer to Procedure 003-008.

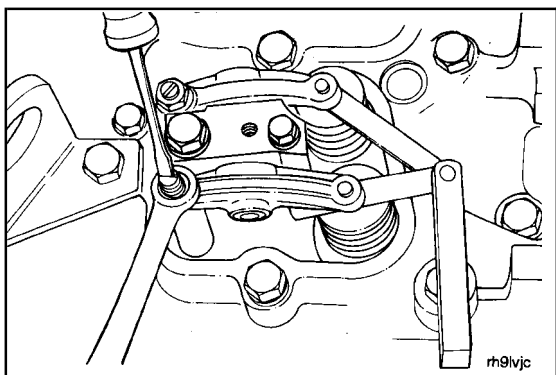

Adjust the valve lash. Refer to Procedure 003-004.

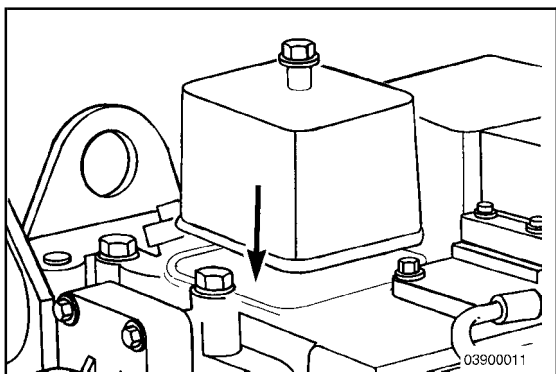

**15 mm**

Install the rocker lever covers, and tighten capscrews.

**Torque Value:** 24 N•m [18 ft-lb]



### Cylinder Head Gasket (002-021)

#### Remove (002-021-002)

Remove the head gasket.

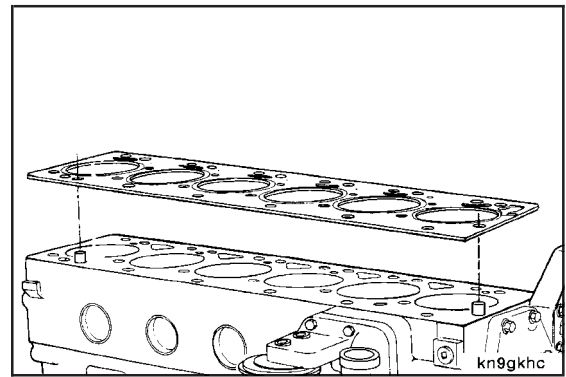

#### Install (002-021-026)

Install the new head gasket.

**NOTE:** Never reuse the old head gasket. Always use a new head gasket to prevent leakage.

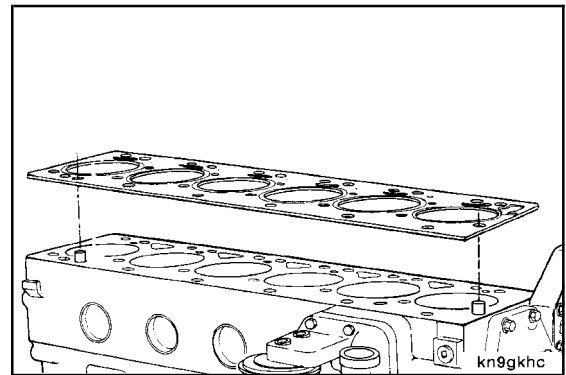

### Injector Protrusion (002-022)

#### General Information

#### Injector Protrusion

Injector protrusion can affect power from the engine. In addition to a single sealing washer (A) on the injector, the thickness (B) of the head gasket controls injector protrusion.

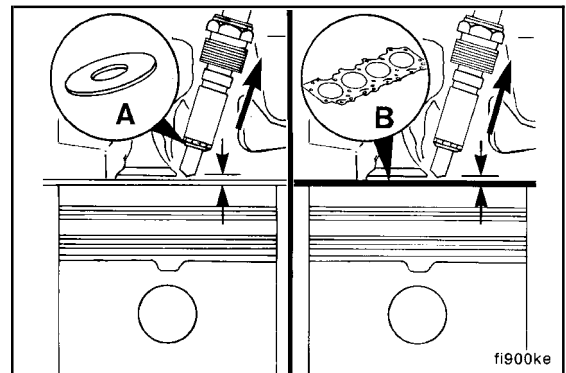

Thicker service head gaskets are used when the head surface on the block has been refaced.

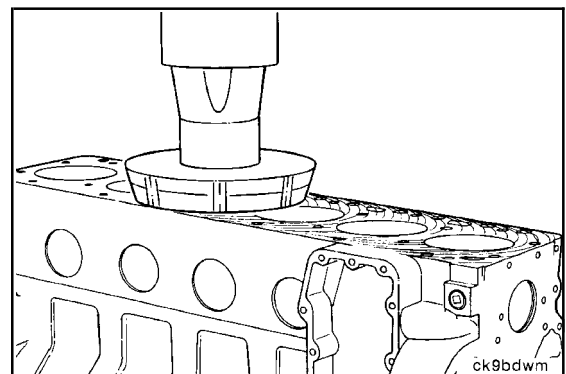

After machining, the block is identified as follows:

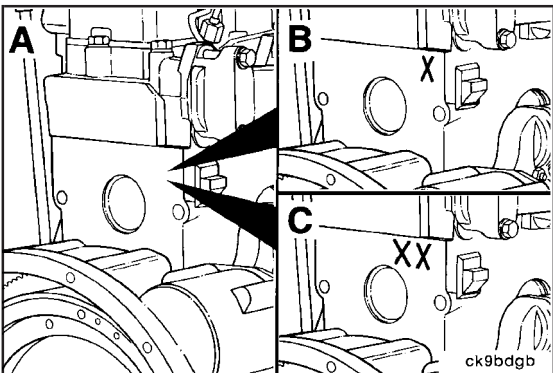

Machining	Mark
A - Standard	None
B - 0.25 mm [0.010 in] machined for first oversized gasket.	X
C - 0.25 mm [0.010 in] machined (0.50 mm [0.020 in] total) for second oversized gasket.	XX

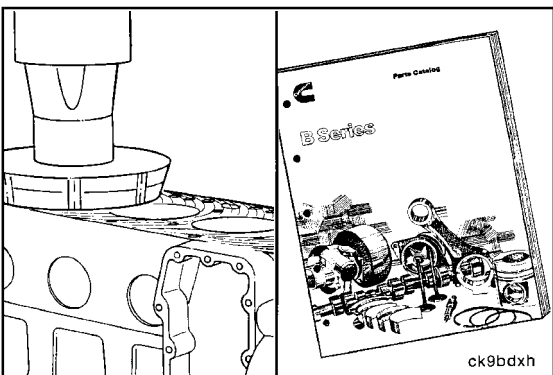

After determining the amount of machining that has been performed, refer to the parts catalog for the proper oversized head gasket.

# Section 3 - Rocker Levers - Group 03

## Section Contents

	<b>Page</b>
<b>Crankcase Breather Tube</b> .....	3-13
Clean .....	3-14
Inspect for Reuse .....	3-14
Install .....	3-14
Remove.....	3-13
<b>Overhead Set</b> .....	3-2
Adjust.....	3-3
General Information .....	3-2
<b>Rocker Lever</b> .....	3-6
Assemble.....	3-10
Clean .....	3-8
Disassemble.....	3-7
Inspect for Reuse.....	3-9
Install.....	3-11
Measure.....	3-9
Remove.....	3-6
<b>Rocker Lever Cover</b> .....	3-12
Clean .....	3-13
Inspect for Reuse .....	3-13
Install .....	3-13
Remove.....	3-12
<b>Service Tools</b> .....	3-1
Rocker Levers .....	3-1

**THIS PAGE LEFT INTENTIONALLY BLANK**

## Service Tools

### Rocker Levers

The following special tools are recommended to perform procedures in this section. The use of these tools is shown in the appropriate procedure. These tools can be purchased from your local Cummins Authorized Repair Location.

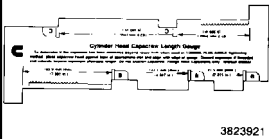
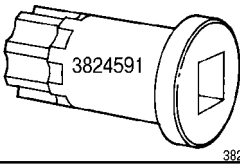
Tool No.	Tool Description	Tool Illustration
3823921	<b>Capscrew Length Gauge</b> Used to measure capscrew free length.	
3824591	<b>Engine Barring Tool</b> Used to engage the flywheel ring gear to rotate the crankshaft.	

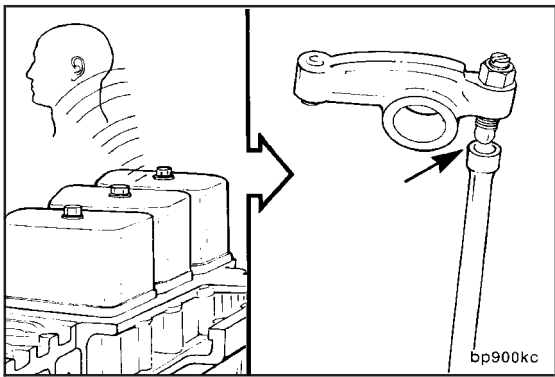

## Overhead Set (003-004)

### General Information

#### Diagnosing Component Malfunctions — Rocker Lever, Valve Stem, Push Tube, Tappet, and Camshaft

The rocker lever group consists of the rocker lever assemblies, rocker assembly oil manifold, valve cover, and crankcase breather.

Each cylinder of the engine has a separate rocker lever assembly. The pedestal support has drillings to route the oil flow to the shaft and levers.

The rocker levers are push tube actuated and use an adjusting screw to control the clearance between the rocker lever and valve stem. The rocker levers do **not** use a bushing in the bore for the rocker lever shaft. The rocker lever **must** be replaced if the bore is damaged or worn beyond the specification limit.

The ball end of the push tube fits into the ball socket in the tappet. The other end of the pushrod has a ball socket in which the ball end of the rocker lever adjusting screw operates.

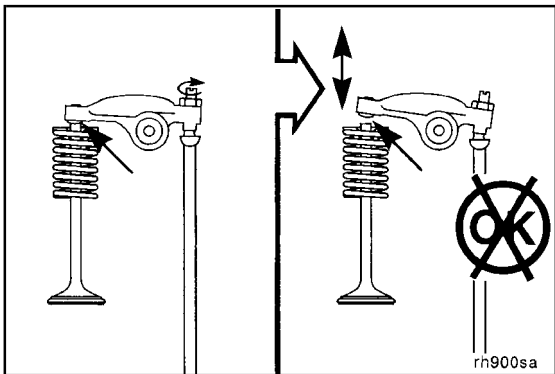
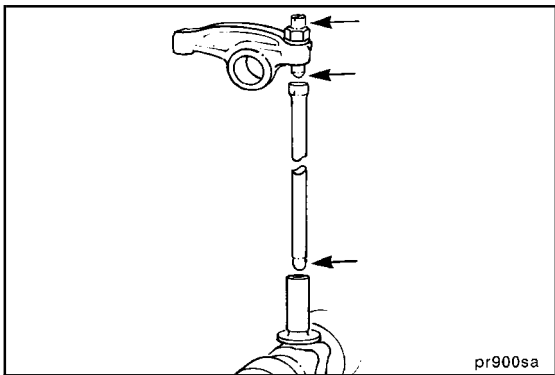

Excessive valve lash can indicate a worn valve stem, push tube, valve tappet, or rocker lever.



**B3.9 and B5.9 Series Engines  
Section 3 - Rocker Levers - Group 03**

Loose rocker levers and the need to reset the valve clearance frequently can also indicate camshaft lobe or tappet wear. If an inspection of the rocker levers, valve stems, and push tubes does **not** show wear, then tappet and/or camshaft lobe wear can be suspected. Refer to Procedures 001-008 and 004-015.

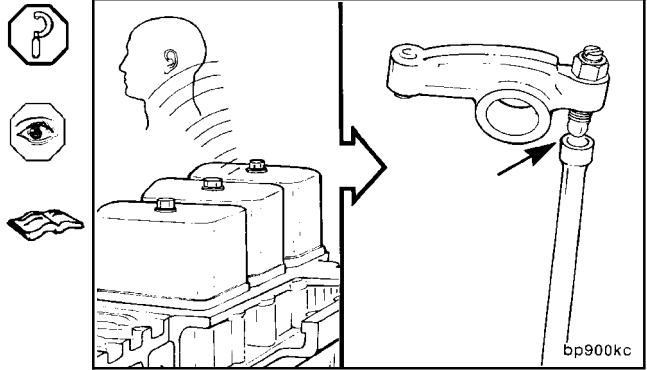

**▲ CAUTION ▲**

**Anytime a new camshaft is installed, new tappets and push tubes must also be installed. Failure to do so can cause severe engine damage.**

The camshaft lobes can be inspected after removing the lubricating oil pan.

The tappets can also be inspected with the lubricating oil pan removed. Remove the push tubes, lift the tappets, and inspect the tappet faces.

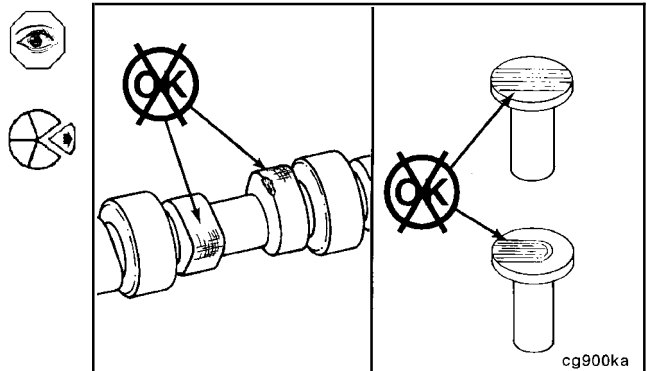

Severely damaged camshaft journal(s) can generate metal chips that will be found in the lubricating oil pan and oil filter.

**NOTE:** As the clearance between the camshaft bushing(s) and camshaft journal(s) increase, oil pressure and volume will decrease, causing damage to the camshaft and tappets.

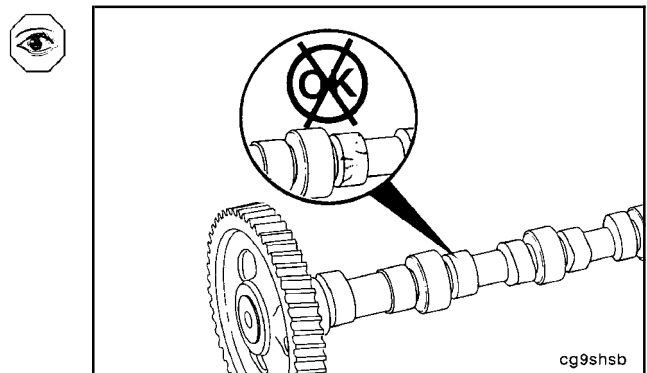

**Adjust (003-004-029)**

**1/2-Inch Drive, Engine Barring Tool, Part No. 3824591**

Locate top dead center (TDC) for cylinder No. 1 by barring the crankshaft slowly while pressing on the engine timing pin. Barring the engine is recommended from the flywheel on the rear of the engine.

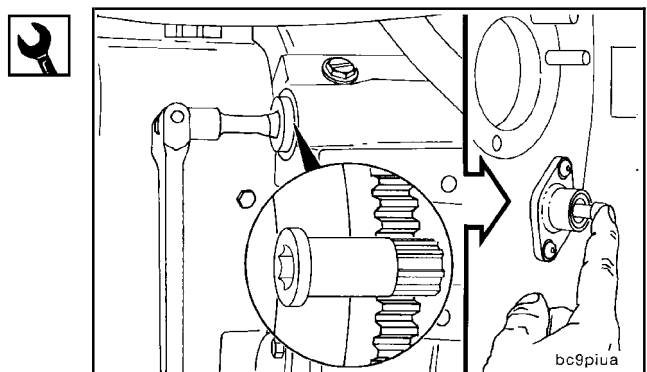

When the timing pin engages in the hole in the camshaft gear, cylinder No. 1 is at TDC on the compression stroke.

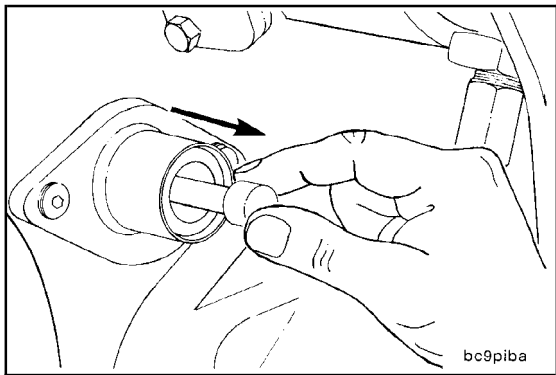
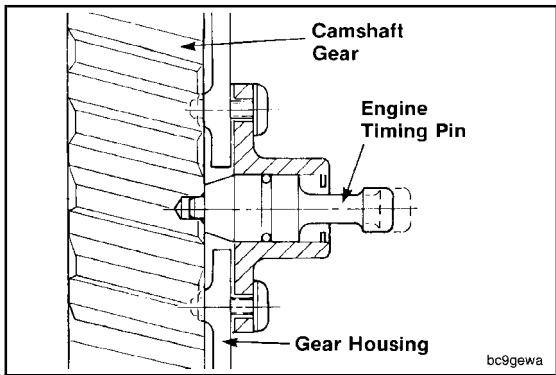

**⚠ CAUTION ⚠**

To avoid engine or timing pin damage, you must disengage the timing pin after locating TDC.

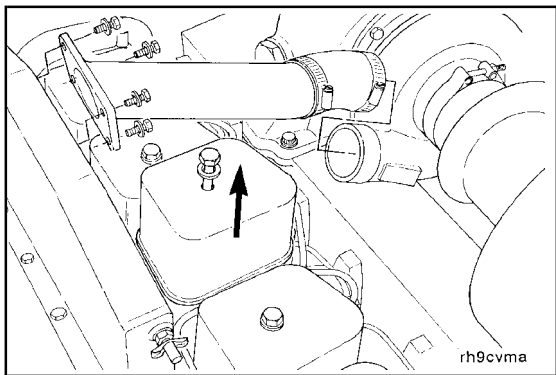

15 mm

Remove the valve cover

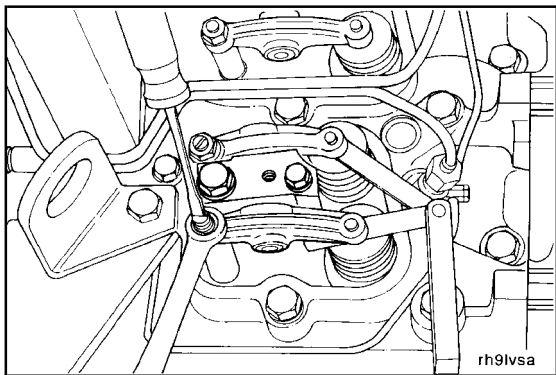

**Feeler Gauge**

**NOTE:** The clearance is correct when some resistance is "felt" when the feeler gauge is slipped between the valve stem and the rocker lever.



**NOTE:** Caution **must** be used when setting the exhaust valve lash on marine cylinder heads with rotators. The top of the valve stem is slightly recessed below the top of the valve rotator.

**Intake Clearance:** 0.254 mm [0.010 in]

**Exhaust Clearance:** 0.508 mm [0.020 in]

**B3.9 and B5.9 Series Engines  
Section 3 - Rocker Levers - Group 03**

**14-mm Wrench, Flat-Blade Screwdriver**

**Four-Cylinder Engine Adjustment**

Locate top dead center (TDC) for cylinder No. 1.

Set **only** valves indicated by the arrows (E = exhaust, I = intake). Do **not** set valves that are **not** indicated.

Holding the locknut steady with the wrench, adjust the valve clearance with the screwdriver or allen wrench.

Tighten the locknut, and measure the valve lash again.

**Torque Value:** 24 N•m [18 ft-lb]

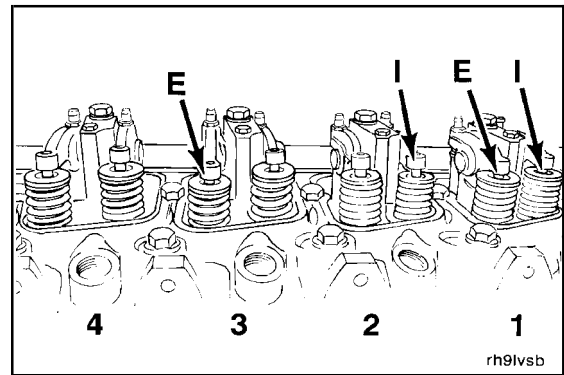

**▲ CAUTION ▲**

**To avoid engine or pin damage, be sure the timing pin is disengaged.**

Mark the vibration damper, and rotate the crankshaft 360 degrees.

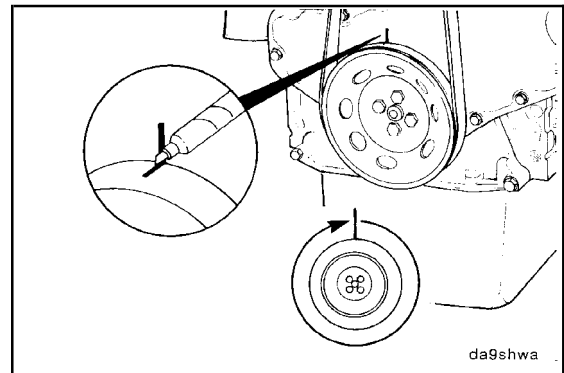

**14-mm Wrench, Flat-Blade Screwdriver, or 5-mm Allen Wrench**

Adjust the valves as indicated in the illustration.

**Torque Value:** 24 N•m [18 ft-lb]

Set **only** valves indicated by the arrows (E = exhaust, I = intake). Do **not** set valves that are **not** indicated.

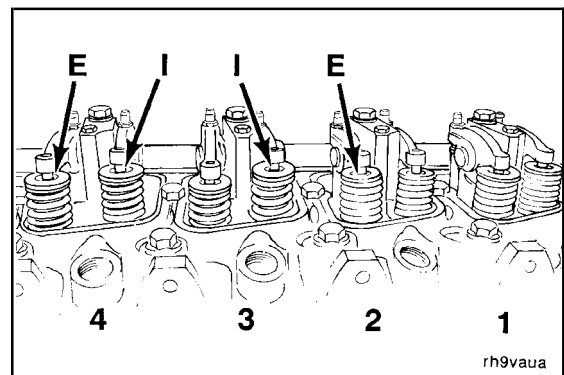

**14-mm Wrench, Flat-Blade Screwdriver**

**Six-Cylinder Engine Valve Adjustment**

Locate top dead center (TDC) for cylinder No. 1.

Set **only** the valves indicated by the arrows in the illustration (E = exhaust, I = intake).

Holding the locknut steady with the wrench, adjust the valve clearance with the screwdriver or allen wrench.

Tighten the locknut, and measure the valve lash again.

**Torque Value:** 24 N•m [18 ft-lb]

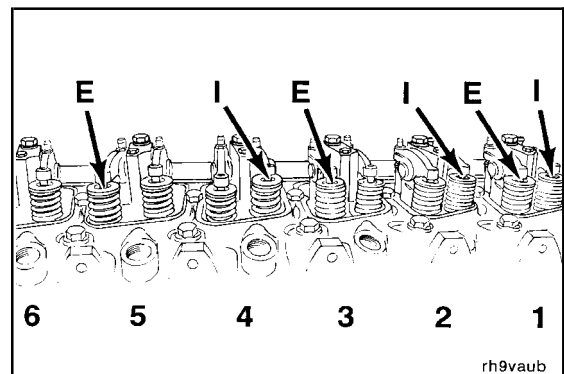

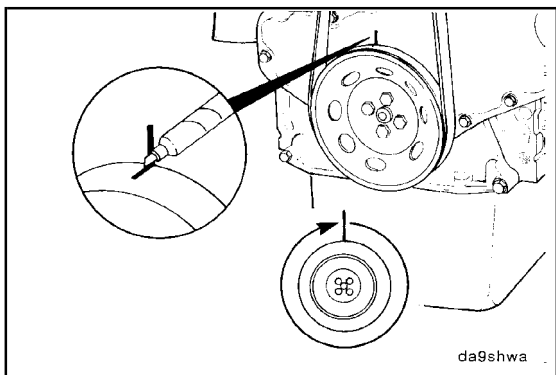

**⚠ CAUTION ⚠**

To avoid engine or pin damage, be sure timing pin is disengaged.

Mark the pulley, and rotate the crankshaft 360 degrees.

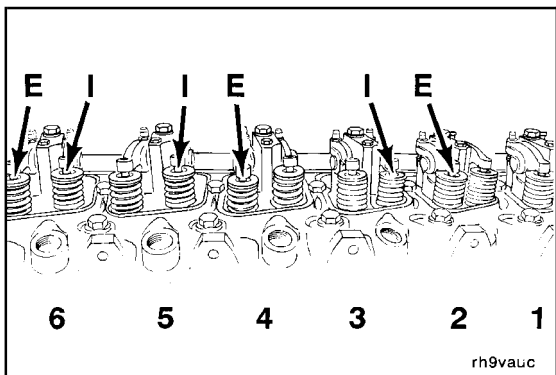

Adjust the valves as indicated in the illustration.



Set **only** the valves indicated by the arrows in the illustration (E = exhaust, I = intake). Do **not** set valves that are **not** indicated.

**Torque Value:** 24 N•m [18 ft-lb]

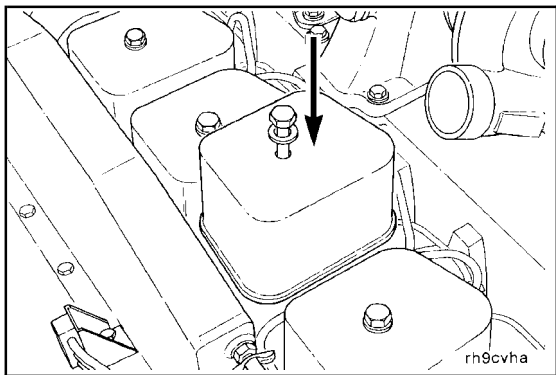

**15 mm**

Install the rocker lever covers, and tighten the capscrews.



**Torque Value:** 24 N•m [18 ft-lb]

Refer to Procedure 003-011.

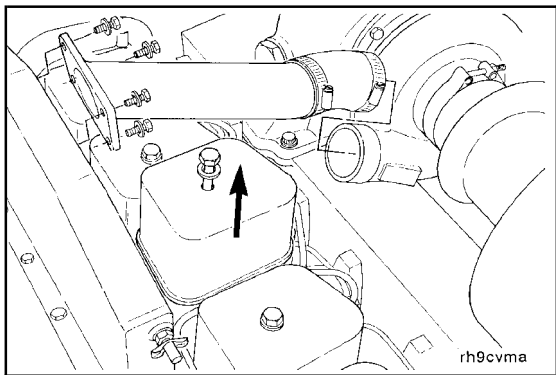

**Rocker Lever (003-008)**

**Remove (003-008-002)**



**15 mm**

Remove the rocker lever covers.

14 mm

Loosen the adjusting screw locknuts. Loosen the adjusting screws until they stop.

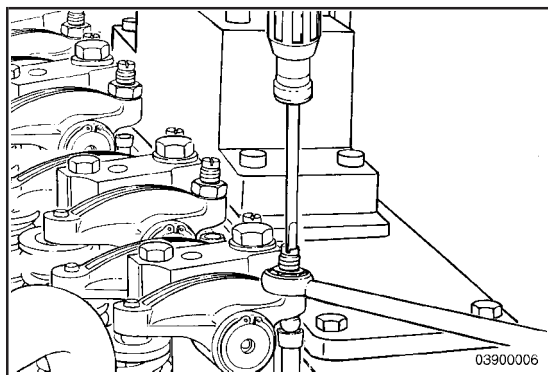

13 mm, 18 mm

Remove the capscrews from the rocker lever pedestals. Remove the pedestals and rocker lever assemblies.

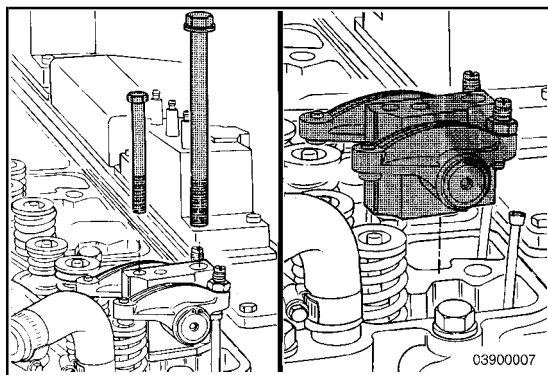

**NOTE:** Mark the push tubes to identify their location.  
Remove the push tubes.

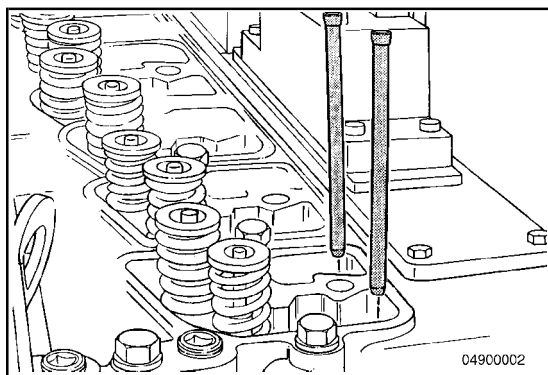

**Disassemble (003-008-003)**

If the rocker lever and push tubes are to be inspected for reuse, follow these steps.

Remove the retaining rings and thrust washers.

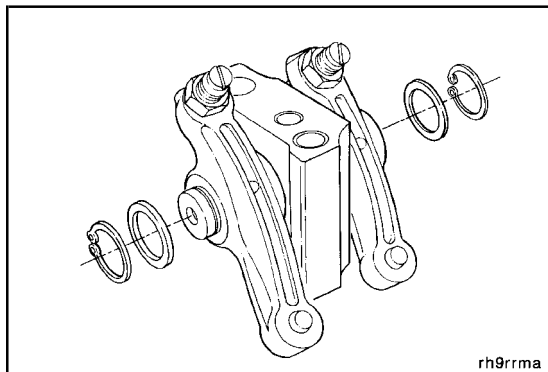

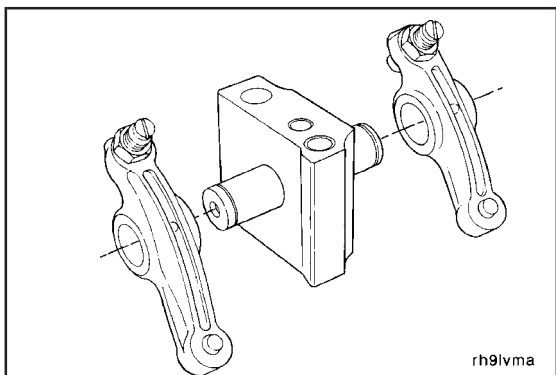

Remove the rocker levers.

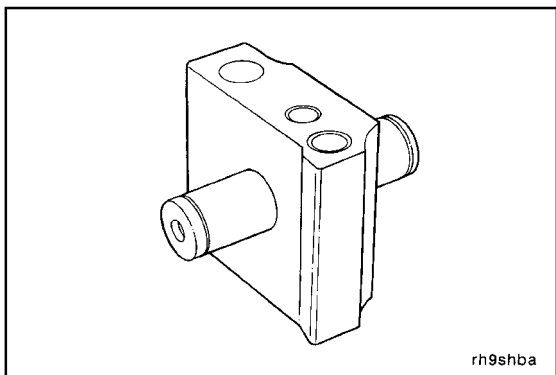

**NOTE:** Do **not** disassemble the rocker lever shaft and pedestal. The pedestal and shaft **must** be replaced as an assembly.

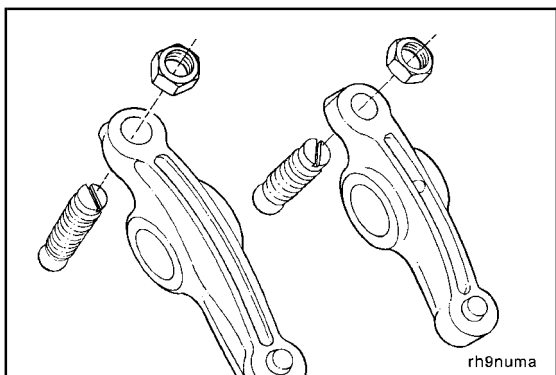

Remove the locknut and adjusting screw.

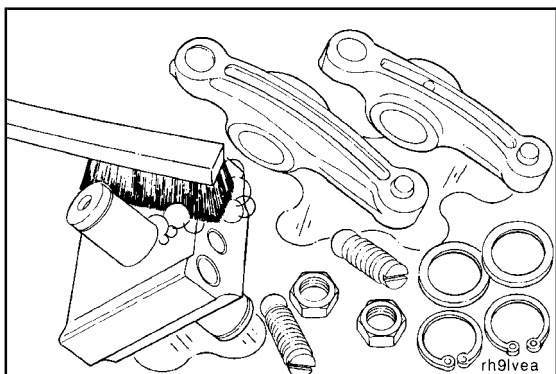

**Clean (003-008-006)**

Clean all parts in a strong solution of detergent in hot water.

**⚠ WARNING ⚠**

Wear appropriate eye and face protection when using compressed air. Flying debris and dirt can cause bodily injury.

Rinse parts with clean, hot water.

Dry with compressed air.

**NOTE:** The pedestals are made from powdered metal and will continue to show wetness after they have been cleaned and dried.

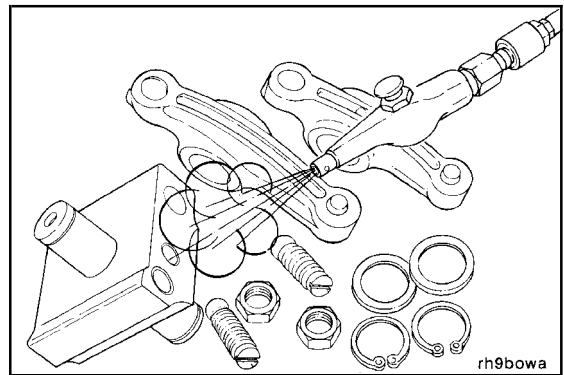

rh9bowa

**Inspect for Reuse (003-008-007)**

Inspect for cracks and excessive wear in the bore and the contact surface of the valve stem.

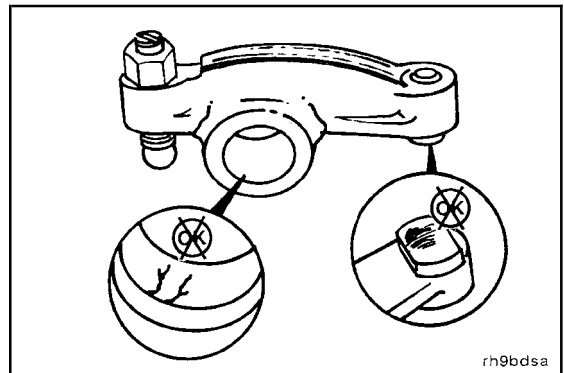

rh9bdsa

**Measure (003-008-010)**

Measure the rocker lever bore.

Rocker Lever Bore		
mm		in
19.00	MIN	0.748

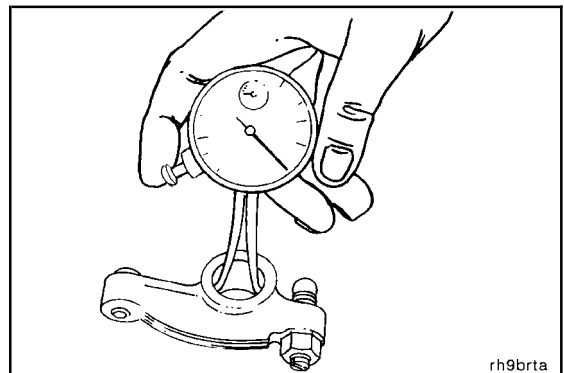

rh9brta

Inspect the pedestal and shaft.

Measure the shaft diameter.

Rocker Lever Shaft		
mm		in
18.98	MAX	0.747

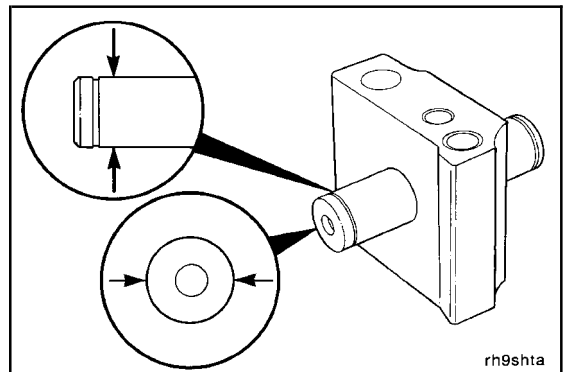

rh9shta

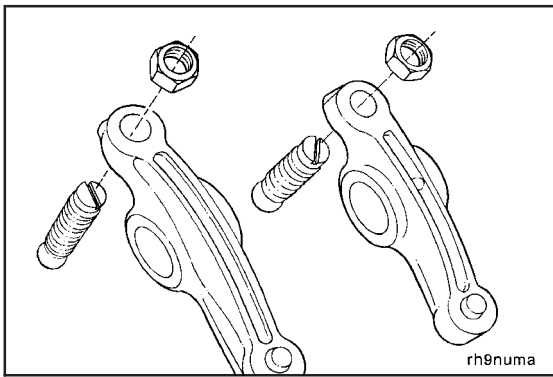

**Assemble (003-008-025)**

Install the adjusting screw and locknut.

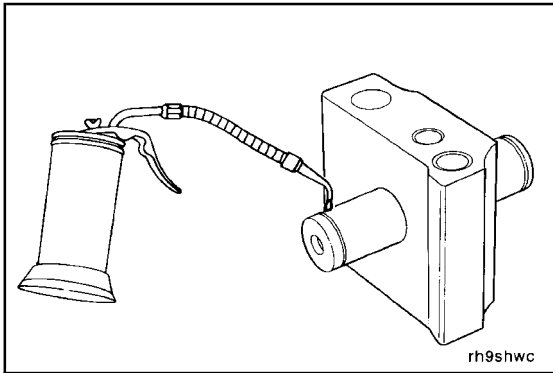

Lubricate the shaft with clean lubricating engine oil.

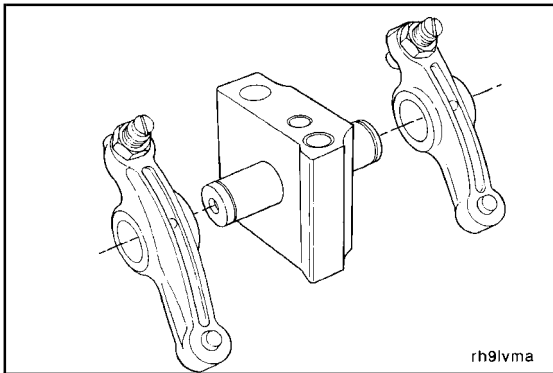

Position the levers on the rocker shaft.

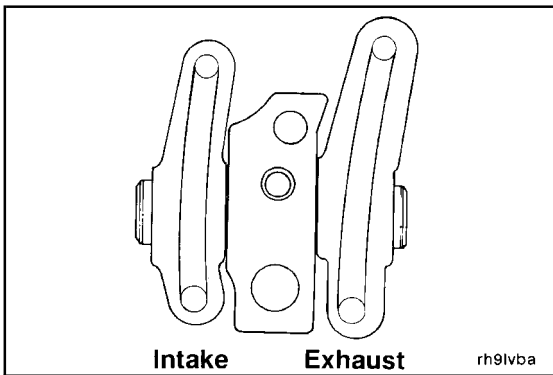

**NOTE:** Be sure to assemble the intake and exhaust rocker levers in the correct location.



Install the thrust washers.

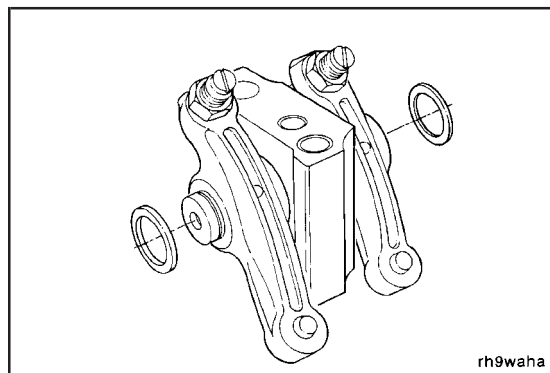

Install the snap rings.

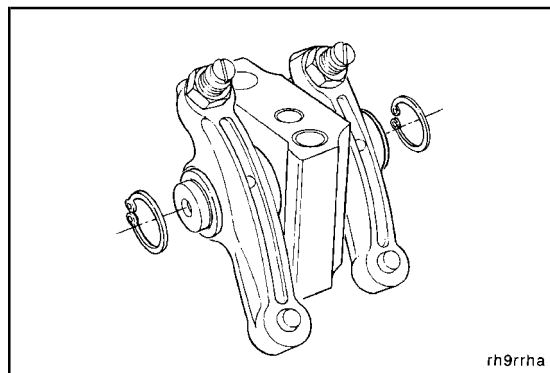

**Install (003-008-026)**

Make sure the dowel rings in the pedestals are installed into the dowel bores.

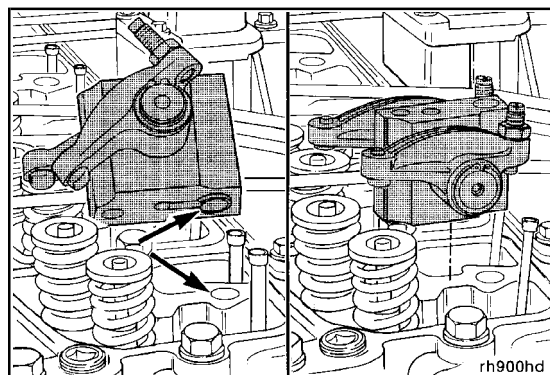

**Capscrew Length Gauge, Part No. 3823921**

Inspect all cylinder head capscrews for proper length using Service Tool Part No. 3823921.

Use clean lubricating engine oil to lubricate the threads and under the heads of the capscrews.

Install the pedestal and cylinder capscrews into the pedestals.

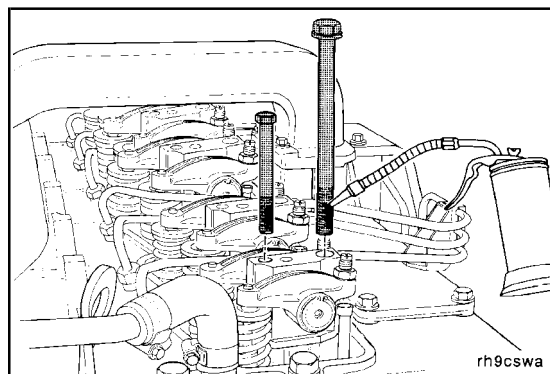

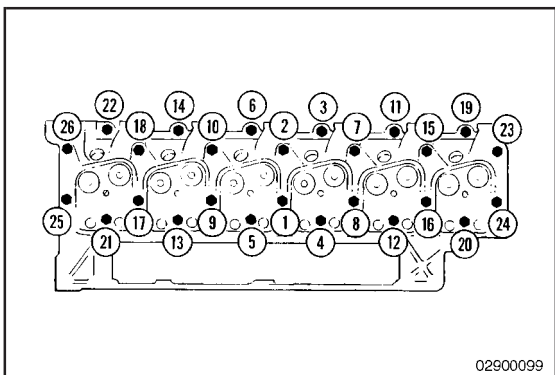

Tighten **all** the cylinder head capscrews following proper torque order. Refer to Procedure 002-004.

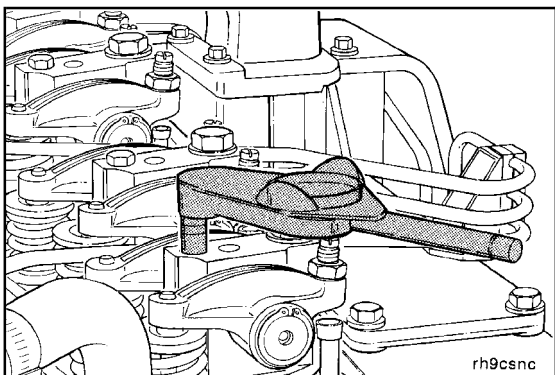

**8 mm**

Tighten the 8-mm pedestal capscrews.



**Torque Value:** 24 N•m [18 ft-lb]

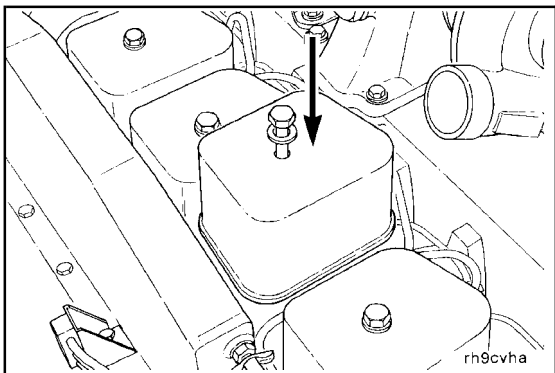

**15 mm**

Install the rocker lever covers.



Inspect washer and grommet for cracks or damage.

**Torque Value:** 24 N•m [18 ft-lb]

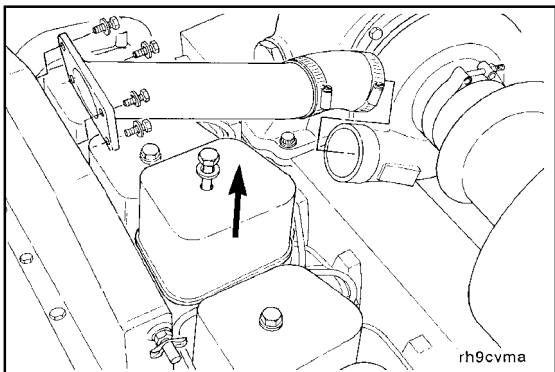

**Rocker Lever Cover (003-011)**

**Remove (003-011-002)**



**15 mm**

Remove the rocker lever covers.

**Clean (003-011-006)**

**▲ WARNING ▲**

Wear appropriate eye and face protection when using compressed air. Flying debris and dirt can cause bodily injury.

Clean rocker lever cover with a strong solution of detergent in hot water.

Dry with compressed air.

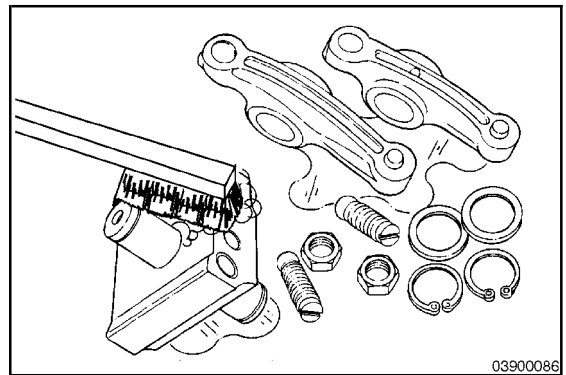

03900086

**Inspect for Reuse (003-011-007)**

Check the rocker lever cover(s) for cracks.

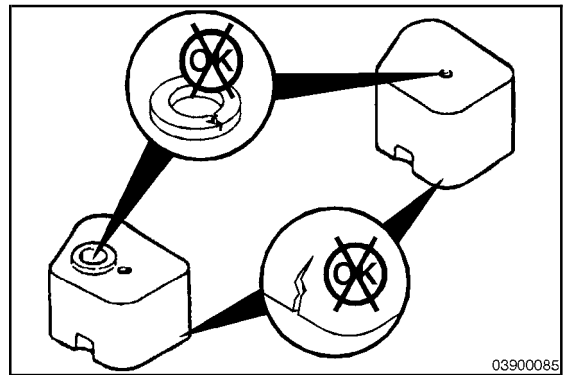

03900085

**Install (003-011-026)**

15 mm

Install rocker lever cover(s).

Tighten the capscrews.

**Torque Value:** 24 mm [18 ft-lb]

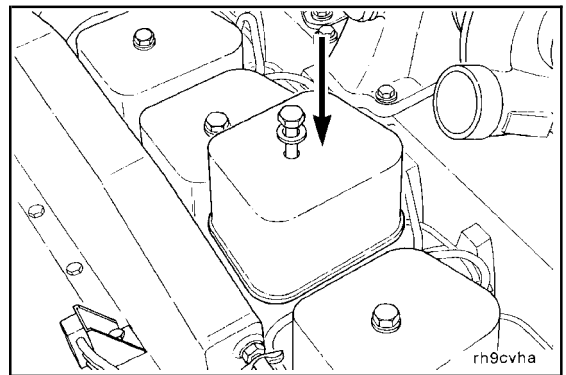

rh9cvha

**Crankcase Breather Tube (003-018)**

**Remove (003-018-002)**

Remove the crankcase breather tube from the side of the engine block.

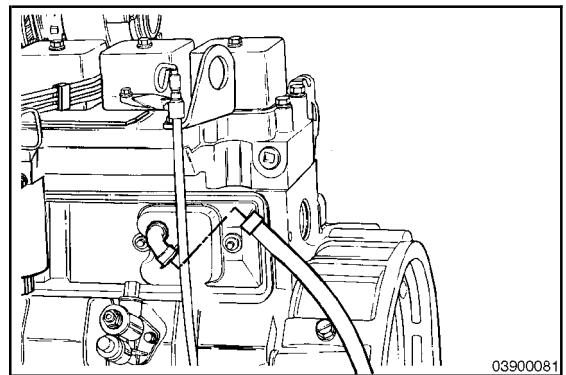

03900081

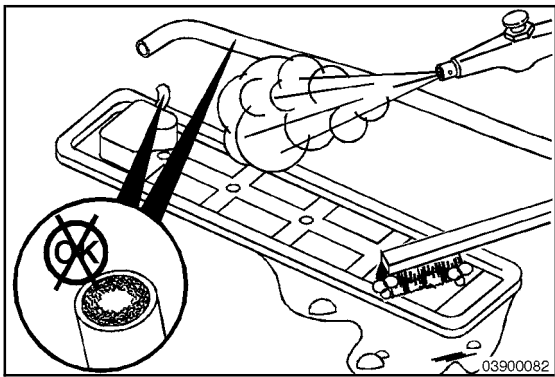

**Clean (003-018-006)**

**▲ WARNING ▲**



Wear appropriate eye and face protection when using compressed air. Flying debris and dirt can cause bodily injury.

Inspect the crankcase breather and tube internally for obstructions or sludge buildup.

If the tube is blocked, the tube and crankcase breather **must** be cleaned with a strong solution of detergent or replaced to prevent excess crankcase pressure buildup.

Dry crankcase breather and tube with compressed air.

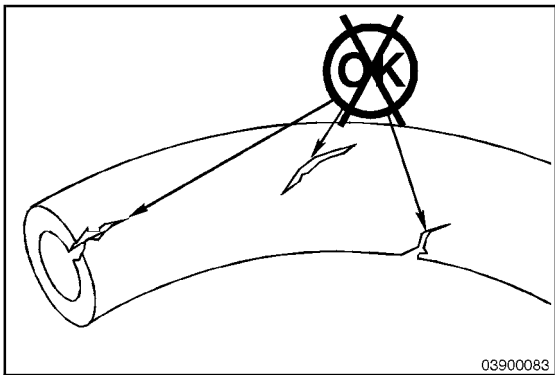

**Inspect for Reuse (003-018-007)**

Check the crankcase breather tube for cracks or other debris, which could obstruct the tube.

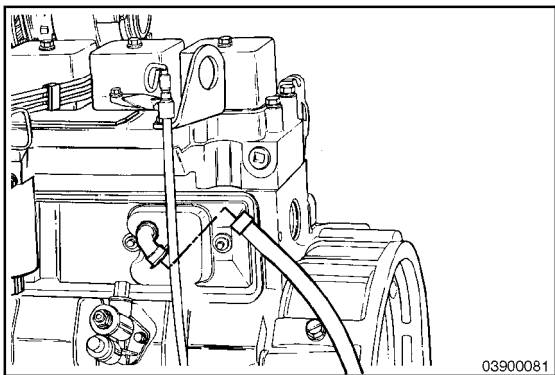

**Install (003-018-026)**

Install the crankcase breather tube to the side of the engine block.

# Section 4 - Cam Followers/Tappets - Group 04

## Section Contents

	Page
<b>Cam Followers/Tappets - General Information</b> .....	4-2
<b>Push Rods or Tubes</b> .....	4-2
Clean .....	4-3
Inspect for Reuse .....	4-3
Install .....	4-4
Preparatory .....	4-2
Remove.....	4-3
<b>Service Tools</b> .....	4-1
Cam Followers/Tappets.....	4-1
<b>Tappet</b> .....	4-5
Clean .....	4-7
Inspect for Reuse.....	4-7
Install .....	4-8
Preparatory .....	4-5
Remove.....	4-5

**THIS PAGE LEFT INTENTIONALLY BLANK**

## Service Tools

### Cam Followers/Tappets

The following special tools are recommended to perform procedures in this section. The use of these tools is shown in the appropriate procedure. These tools can be purchased from your local Cummins Authorized Repair Location.

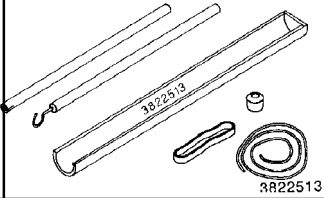
Tool No.	Tool Description	Tool Illustration
3822513	<b>Tappet Removal Tool Kit</b> Used to remove and install valve tappets.	

## Cam Followers/Tappets - General Information

### Valve Tappets and Push Tubes

The valve tappets are mushroom-shaped. The convex shape of the surface that contacts the camshaft lobe causes the tappets to rotate as it lifts the push tube.

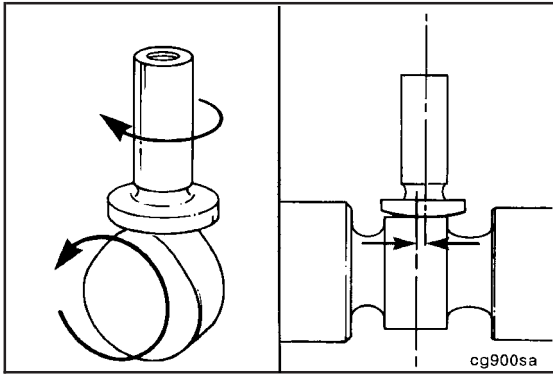

The ball end of the push tube fits into a ball socket in the tappet. The other end of the push tube is fitted with a socket into which the ball end of the rocker lever adjusting screw operates.

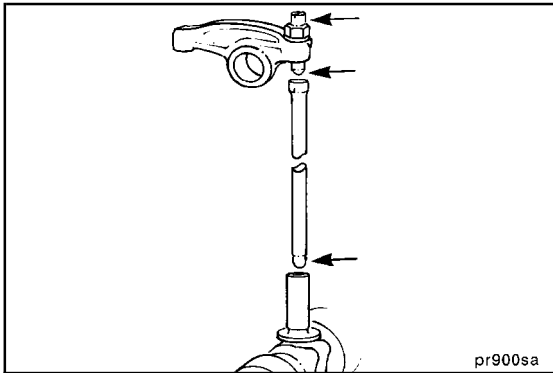

 A loose rocker lever and the need to reset the valve clearance frequently can indicate camshaft lobe or valve tappet wear. If an inspection of the levers, valve stems, and push tubes does **not** show wear, then valve tappet and/or camshaft lobe wear can be suspected.

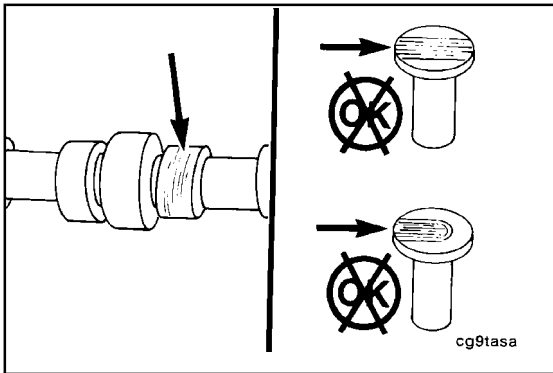

### Push Rods or Tubes (004-014)

#### Preparatory (004-014-000)

- Remove the rocker lever cover(s). Refer to Procedure 003-011.
- Remove the rocker levers. Refer to Procedure 003-008.

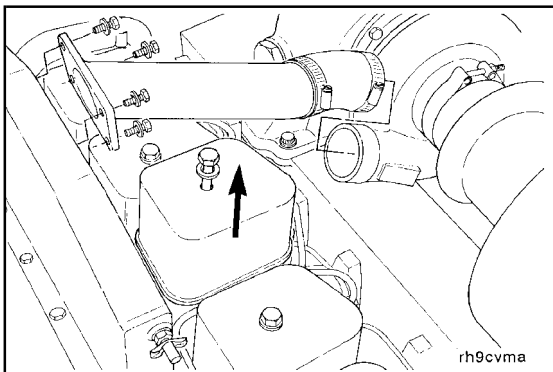



**Remove (004-014-002)**

Remove the push tubes.

**NOTE:** Mark the push tubes to indentify their location.

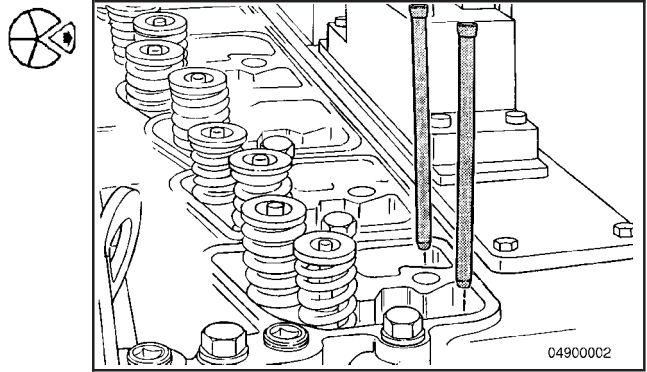

**Clean (004-014-006)**

Clean the push tubes in hot, soapy water.

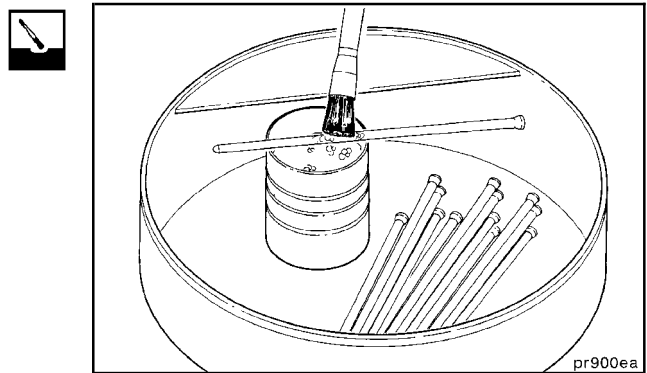

**Inspect for Reuse (004-014-007)**

Inspect the push tube ball and socket for signs of scoring. Check for cracks where the ball and the socket are pressed into the tube.

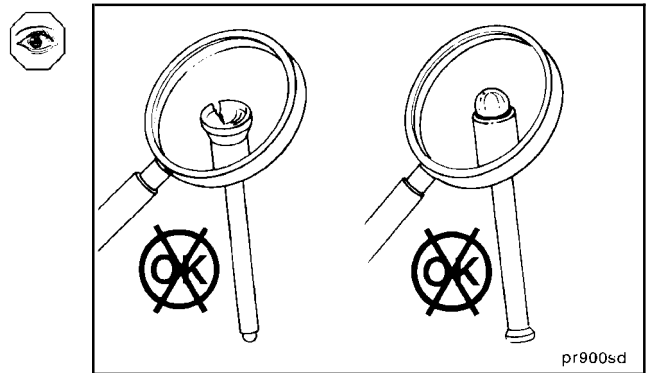

Check the push tubes for roundness and straightness.

**NOTE:** When a push tube is replaced, the corresponding tappet **must** be replaced as well.

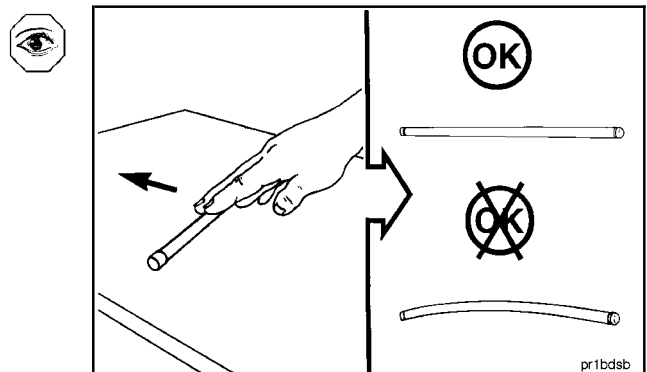

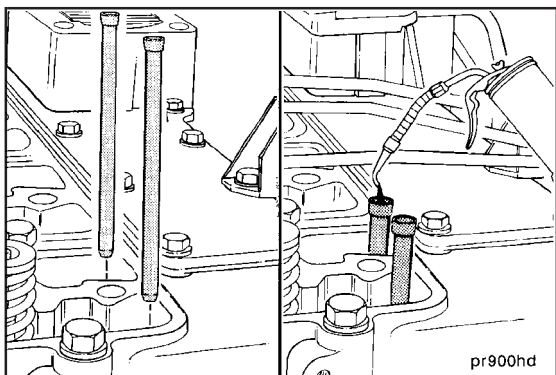

**Install (004-014-026)**

Install the push tubes into the sockets of the valve tappets.

Lubricate the push tube sockets with clean lubricating engine oil.



**NOTE:** The push tubes and tappets **must** be installed in the same cylinder and intake or exhaust position from which they were removed.

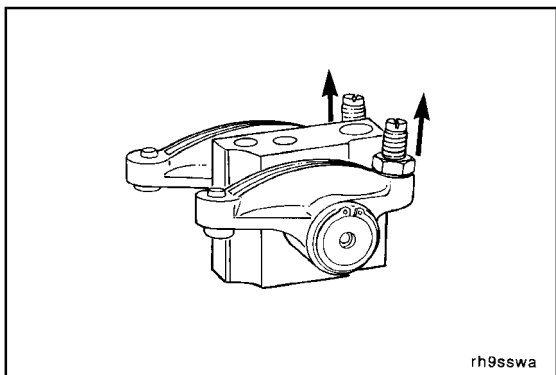

Make sure the rocker lever adjusting screws are completely backed out.

Install the rocker levers. Refer to Procedure 003-008.

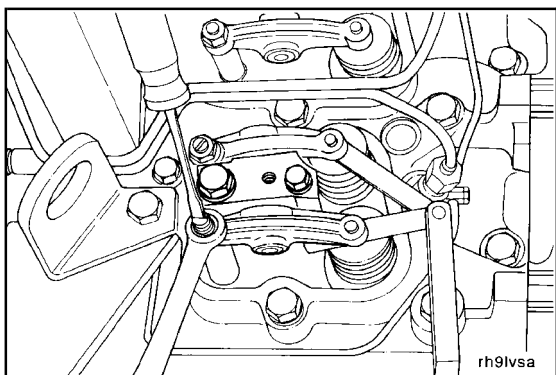

Adjust the valves. Refer to Procedure 003-004.

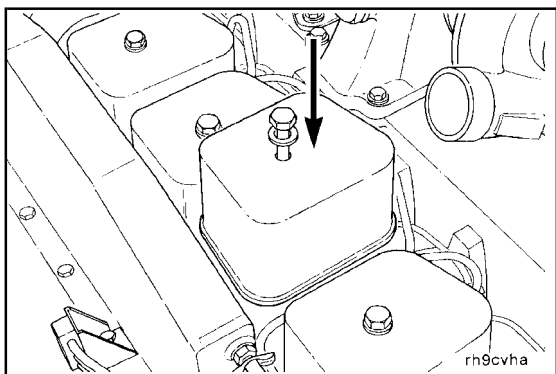

Install rocker lever cover(s) and gasket(s). Refer to Procedure 003-011.

Tighten all capscrews.



**Torque Value:** 24 N•m [18 ft-lb]



## Tappet (004-015)

### Preparatory (004-015-000)

- Remove the rocker lever cover. Refer to Procedure 003-011.
- Remove the rocker levers. Refer to Procedure 003-008.
- Remove the push tubes. Refer to Procedure 004-014.
- Remove the vibration damper. Refer to Procedure 001-052.
- Remove the gear cover. Refer to Procedure 001-031.
- Remove the camshaft. Refer to Procedure 001-008.

### Remove (004-015-002)

#### Tappet Replacement Kit, Part No. 3822513

Insert the trough from the tappet replacement kit, Part No. 3822513, to the full length of the cam bore.

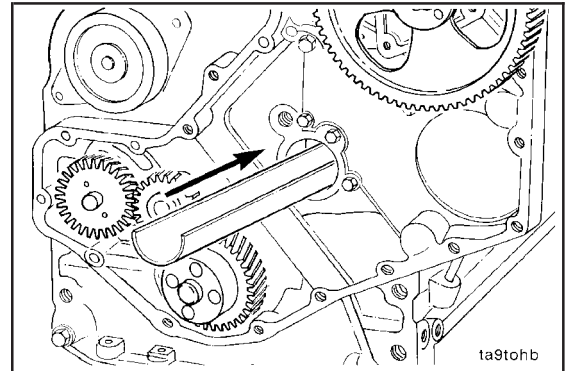

**NOTE:** Number each tappet with the cylinder number position as it is removed. Tappets **must** be installed in the same position as removed.

Make sure the trough is positioned so it will catch the tappet when the wooden dowel is removed.

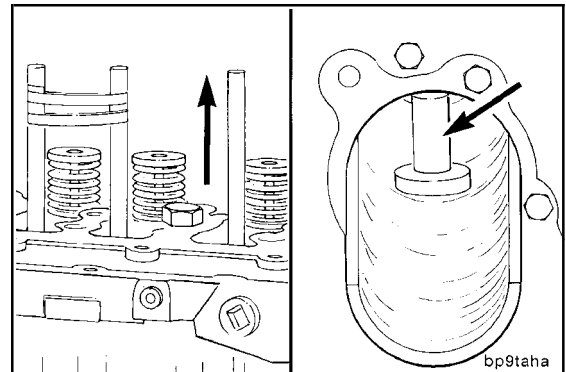

Only remove one tappet at a time. Remove the rubber band from the two companion tappets, securing the tappet **not** to be removed with the rubber band.

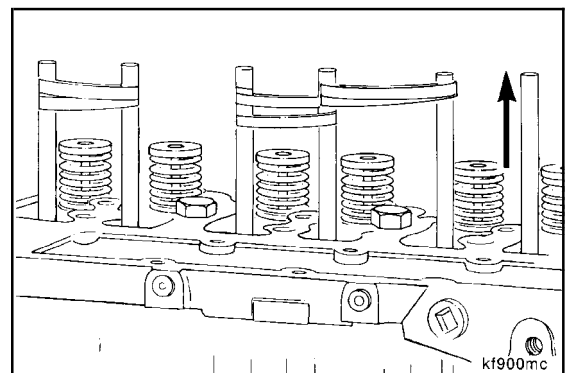

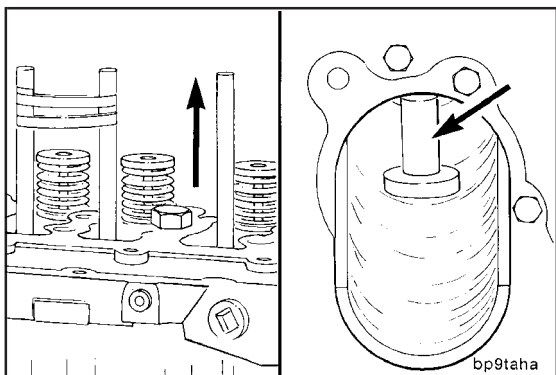

Pull the wooden dowel from the tappet bore allowing the tappet to fall into the plastic trough.

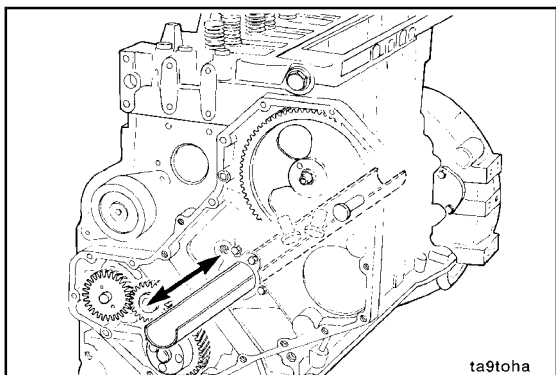

**Flashlight**

When the tappet is dropped into the trough, most of the time it will fall over. However, if it does **not**, gently shake the trough just enough to allow the tappet to fall over before removing.

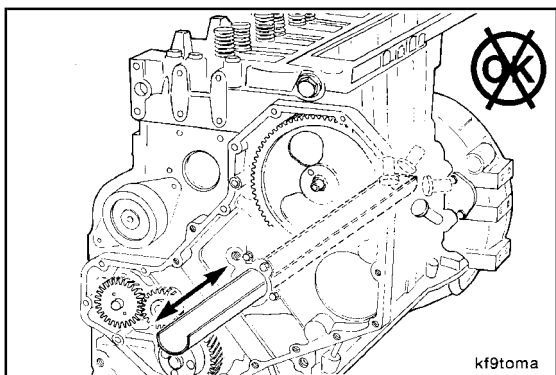

**NOTE:** When removing the No. 6 cylinder tappets, take special care **not** to knock or shake the tappet over the end of the trough.

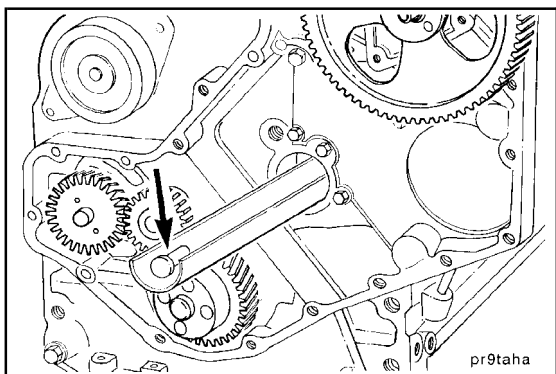

Carefully pull the trough and tappet from the cam bore, and remove the tappet. Repeat the process until all tappets are removed.

**Clean (004-015-006)**

**⚠ WARNING ⚠**

Wear appropriate eye and face protection when using compressed air. Flying debris and dirt can cause bodily injury.

Clean tappets with a strong solution of detergent.

Dry with compressed air.

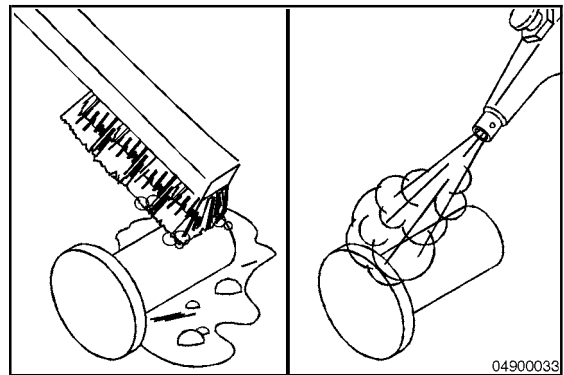

04900033

**Inspect for Reuse (004-015-007)**

**⚠ CAUTION ⚠**

Anytime a new camshaft is installed, new tappets and push tubes must also be installed.

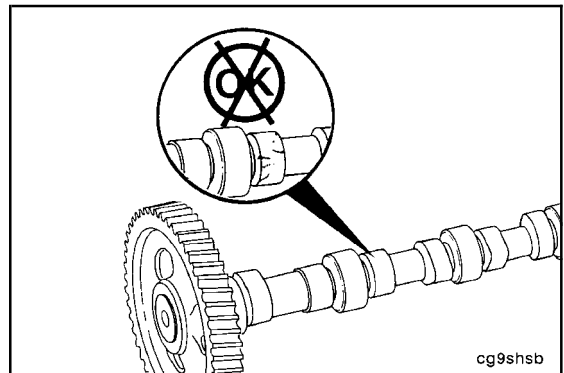

cg9shsb

**⚠ CAUTION ⚠**

If some of the tappets are found to be in need of replacing, the corresponding push tubes must also be replaced. Failure to do so can cause severe engine damage.

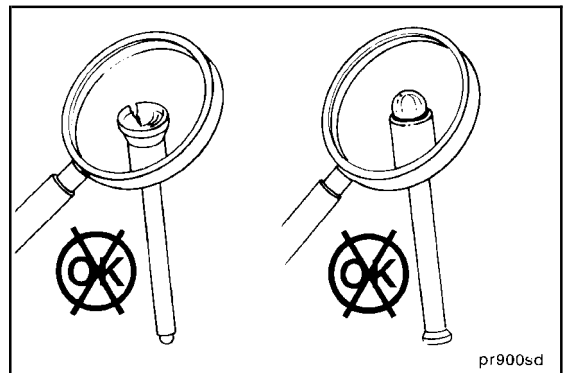

pr900sd

Inspect the socket, stem, and face for excessive wear, cracks, and other damage.



**Visual Limits**

- (A) - Normal Contact (exaggerated)
- (B) and (C) - Irregular Contact: Do **not** reuse.

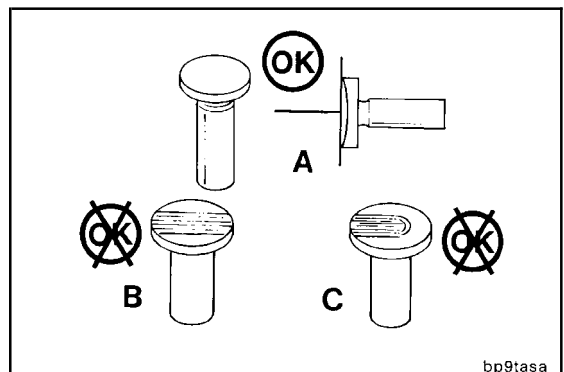

bp9tasa

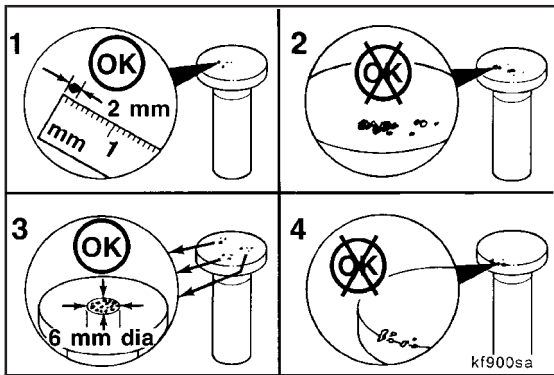

Pit marks on the tappet face are acceptable.

The following criteria defines the size of the pits allowed.

1. A single pit can **not** be greater than 2 mm [0.078 in].
2. Interconnection of pits is **not** allowed.
3. Total pits when added together should **not** exceed 6-mm [0.236-in] diameter or a total of 4 percent of the tappet face.
4. No pitting is allowed on the edges of the wear face of the tappet.

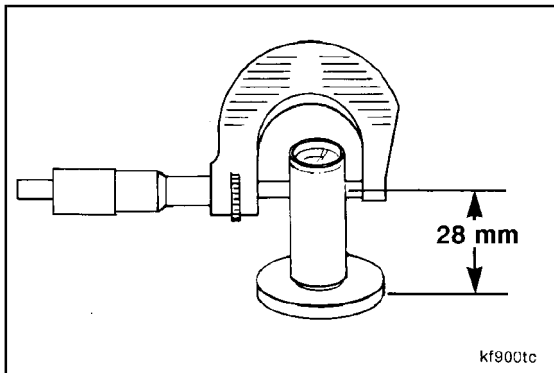

Measure the valve tappet stem.

Valve Tappet Stem Diameter		
mm		in
15.936	MIN	0.627
15.977	MAX	0.629

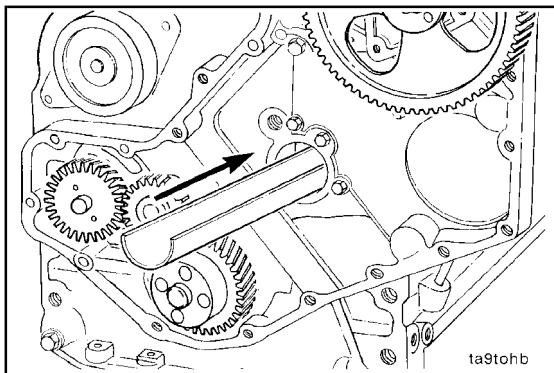

**Install (004-015-026)**

Insert the plastic trough the full length of the cam bore.

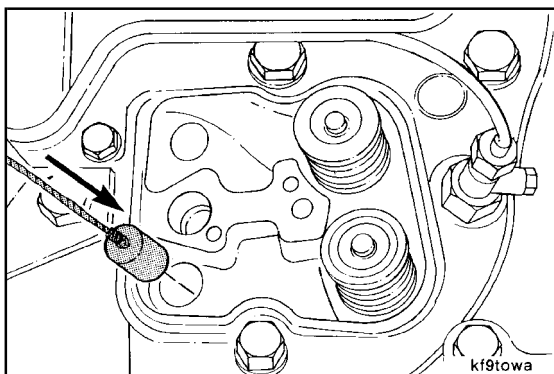

Lower the tappet installation tool down the push tube hole, through the tappet bore, and into the trough.

**B3.9 and B5.9 Series Engines**  
**Section 4 - Cam Followers/Tappets - Group 04**

Feed the installation tool through the cam bores by carefully pulling the trough/installation tool out the front. The barrier at the rear of the trough will pull the tool out most of the time.

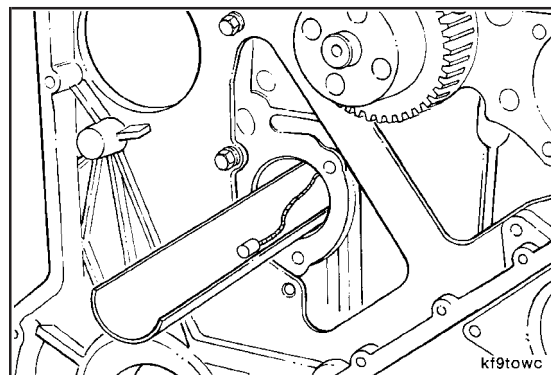

kf9towc

**NOTE:** If the tappets have previously been used, each tappet **must** be installed in the same position as it was removed from the engine.



Lubricate the tappets with clean lubricating engine oil.

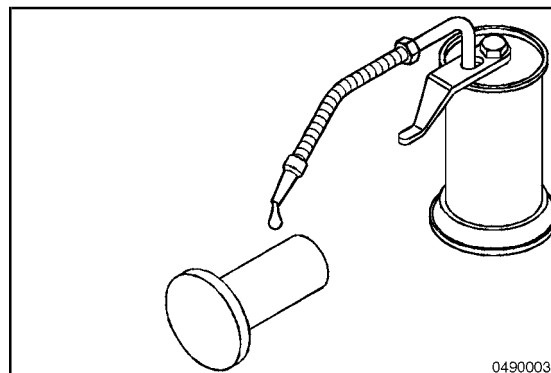

04900034

Insert the installation tool into the tappet.

**NOTE:** To aid in removing the installation tool after the tappet is installed, work the tool in and out of the tappet several times before installing the tappets.

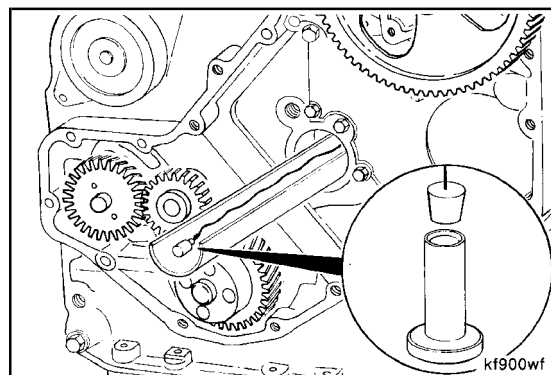

kf900wf

Slide the trough into the cam bore.

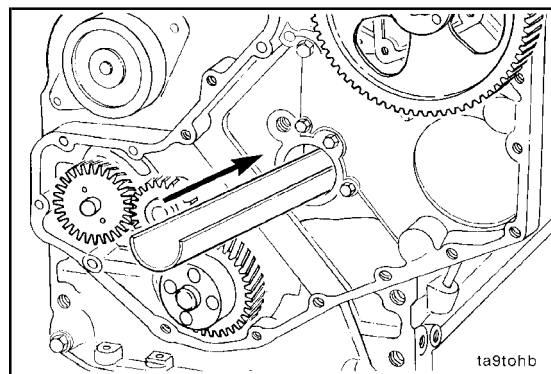

ta9tohb

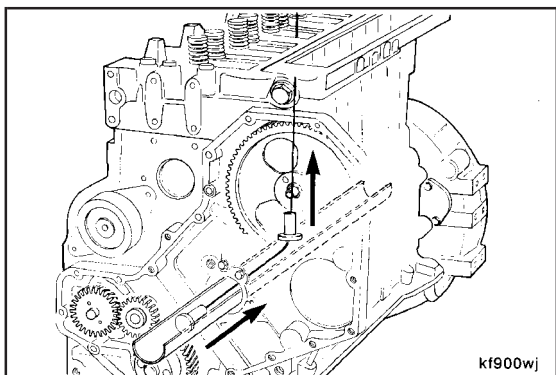

Pull the tool and tappet through the cam bore and up into the tappet bore.

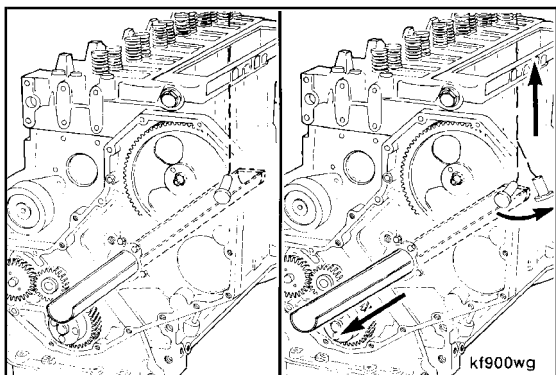

If difficulty is experienced in getting the tappet to make the bend from the trough up to the tappet bore, pull the trough out enough to allow the tappet to drop down and align itself; then, pull the tappet up into the bore.

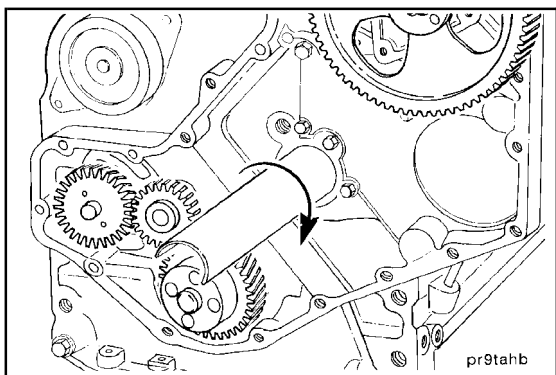

After the tappet has been pulled up into position, slide the trough back into the cam bore, and rotate it one-half of a turn. This will position the round side of the trough up, which will hold the tappet in place.

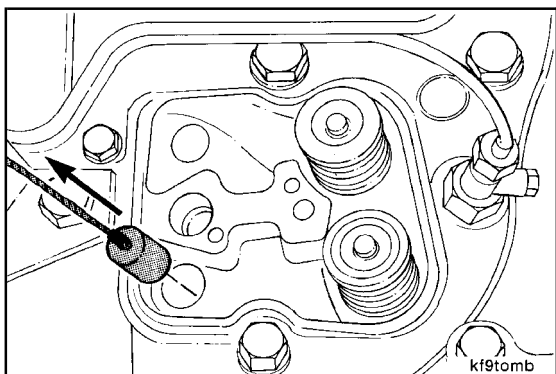

Remove the installation tool from the tappet.



**B3.9 and B5.9 Series Engines**  
**Section 4 - Cam Followers/Tappets - Group 04**

Install a wooden dowel into the top of the tappet. Wrap rubber bands around the wooden dowels to secure the tappets.

Repeat this process until all tappets have been installed.

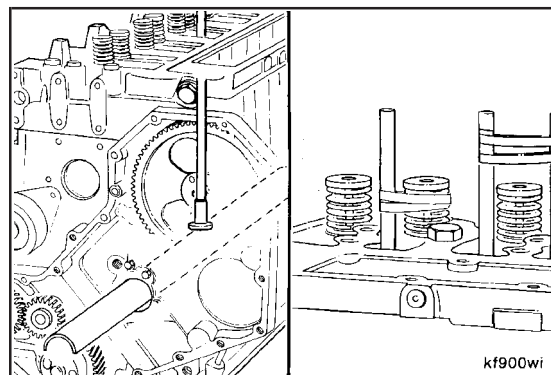

Install the camshaft. Refer to Procedure 001-008.

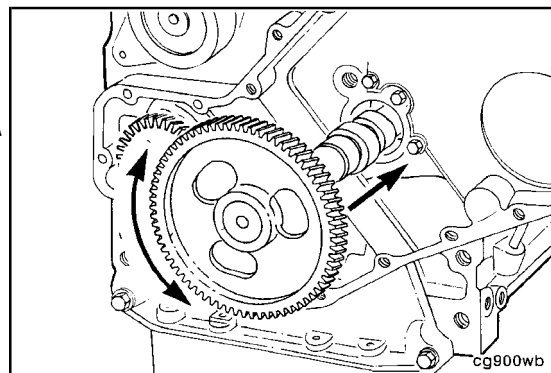

Remove the dowel rods and release the tappets in the tappet bores.

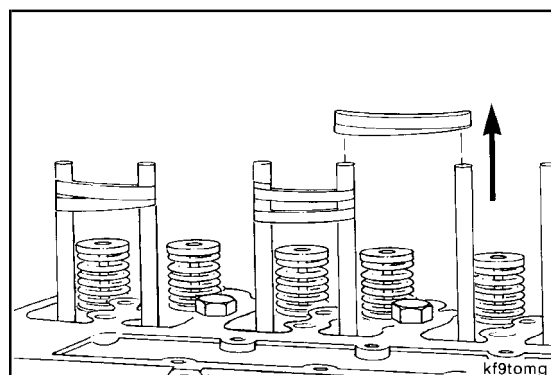

Install the gear cover. Refer to Procedure 001-031.

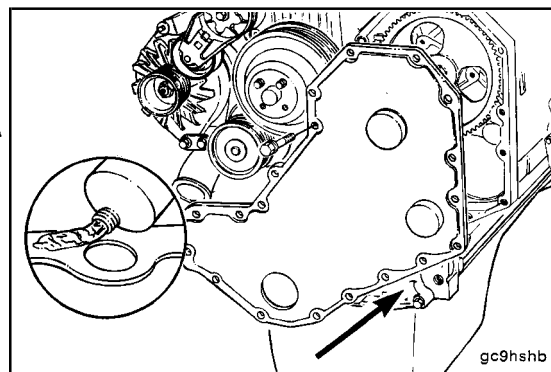

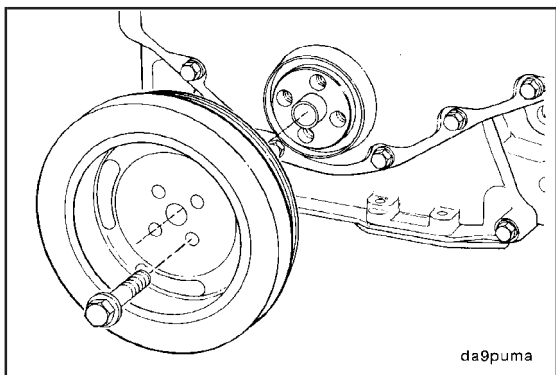

Install the vibration damper. Refer to Procedure 001-052.

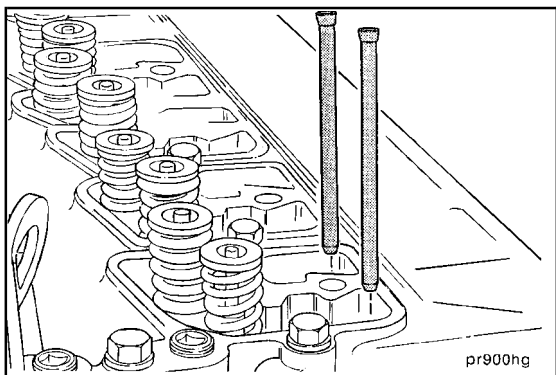

Install the push tubes. Refer to Procedure 004-014.

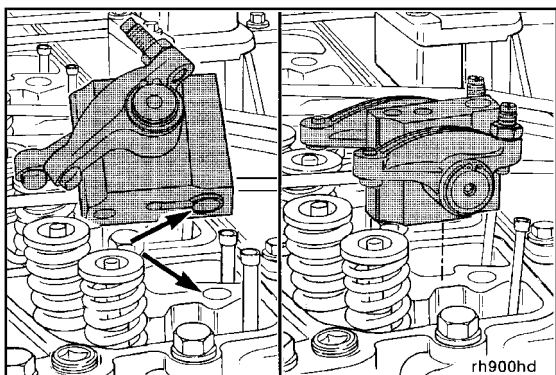

Install the rocker levers. Refer to Procedure 003-008.

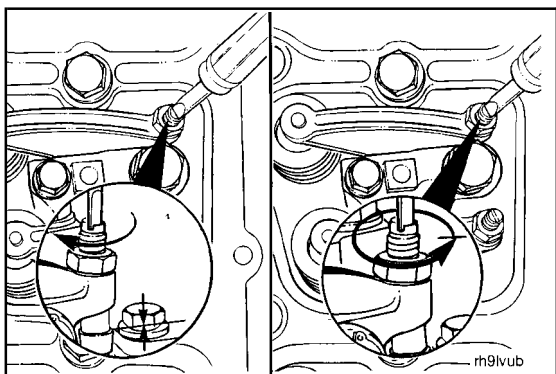

Adjust the valves. Refer to Procedure 003-004.

**B3.9 and B5.9 Series Engines**  
**Section 4 - Cam Followers/Tappets - Group 04**

Install the rocker lever cover(s). Refer to Procedure 003-011.

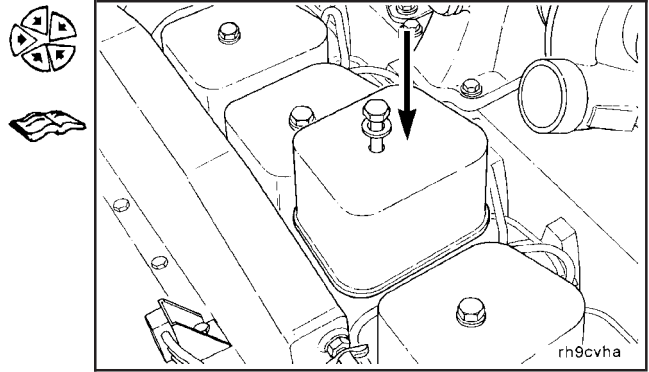

Fill the engine with clean lubricating engine oil and coolant. Refer to Procedures 007-025 and 008-018.

Add coolant and lubricating engine oil, if necessary, to reach correct levels.

Operate the engine until the coolant temperature reaches 82°C [180°F], and check for leaks and proper operation.

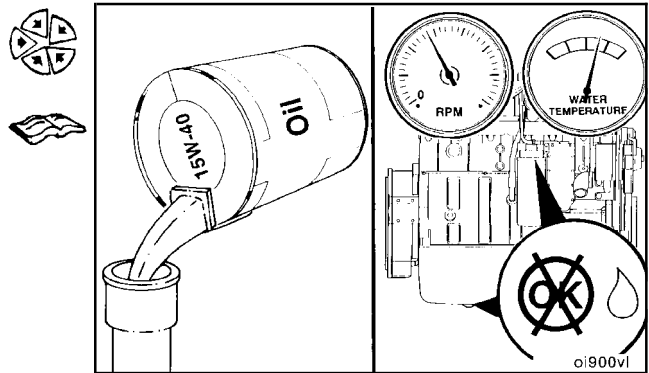



## Section 5 - Fuel System - Group 05

### Section Contents

	Page
<b>AFC Assembly</b> .....	5-9
General Information .....	5-9
<b>Cold Start Timing Advance System (KSB) Pump Mounted</b> .....	5-100
Assemble .....	5-107
Clean .....	5-106
Disassemble .....	5-106
General Information .....	5-100
Resistance Check .....	5-103
Electrical Solenoid Style .....	5-104
Wax-Motor Style .....	5-103
Test .....	5-106
<b>Cold Start Timing Advance System (KSB) Remote</b> .....	5-86
Assemble .....	5-91
Clean .....	5-90
Disassemble .....	5-89
General Information .....	5-86
Resistance Check .....	5-92
Test .....	5-91
<b>Cold Start Timing Advance System (KSB) Temperature Switch</b> .....	5-98
Install .....	5-100
Remove .....	5-98
Test .....	5-99
Electrical Solenoid Style .....	5-99
Wax-Motor Style .....	5-99
<b>Engine Fuel Heater, Electric</b> .....	5-9
Initial Check .....	5-9
Install .....	5-10
Remove .....	5-9
<b>Flow Diagram, Fuel System</b> .....	5-5
<b>Fuel Consumption</b> .....	5-11
Measure .....	5-11
<b>Fuel Flow</b> .....	5-15
Pressure Test .....	5-15
<b>Fuel Injection Pump, In-Line, Spill Port Timing</b> .....	5-28
Plunger Lift Timing .....	5-34
Time .....	5-28
<b>Fuel Injection Pump, Rotary</b> .....	5-45
General Information .....	5-45
Install .....	5-51
Preparatory .....	5-48
Remove .....	5-48
<b>Fuel Injection Pumps, In-Line</b> .....	5-17
General Information .....	5-17
Install .....	5-22
Preparatory .....	5-20
Remove .....	5-20
<b>Fuel Lift Pump</b> .....	5-75
Install .....	5-85
Preparatory .....	5-75
Remove .....	5-75
Test .....	5-76
Vent .....	5-85
<b>Fuel Pump Back Leakage Valve</b> .....	5-95
Inspect for Reuse .....	5-96
Install .....	5-96
CAV .....	5-96

	Page
Preparatory.....	5-95
Remove.....	5-95
CAV .....	5-95
<b>Fuel Pump Control Lever and Spring</b> .....	5-56
Adjust.....	5-56
<b>Fuel Pump High Idle Speed</b> .....	5-56
General Information .....	5-56
<b>Fuel Pump Idle Speed</b> .....	5-56
Adjust.....	5-56
<b>Fuel Pump Pressure Regulator</b> .....	5-97
Clean .....	5-97
Inspect for Reuse .....	5-97
Install .....	5-98
Remove.....	5-97
<b>Fuel Pump Support Bracket</b> .....	5-60
Install .....	5-60
Remove.....	5-60
<b>Fuel Pump Timing</b> .....	5-61
General Information .....	5-61
Time.....	5-61
<b>Fuel Recommendations and Specifications</b> .....	5-8
Fuel Recommendations .....	5-8
<b>Fuel Shutoff Valve</b> .....	5-68
General Information .....	5-68
Install .....	5-74
Preparatory.....	5-69
Remove.....	5-70
Test .....	5-71
<b>Fuel System - General Information</b> .....	5-3
<b>Service Tools</b> .....	5-1
Fuel System .....	5-1
<b>Specifications</b> .....	5-6
Fuel System .....	5-6
<b>Speed Droop Governor</b> .....	5-94
Adjust.....	5-94

## Service Tools Fuel System

The following special tools are recommended to perform procedures in this section. The use of these tools is shown in the appropriate procedure. These tools can be purchased from your local Cummins Authorized Repair Location.

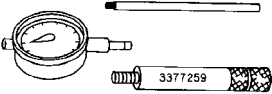
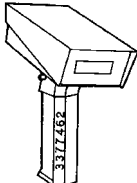
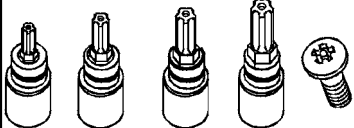
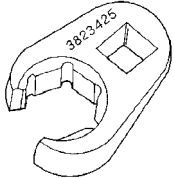
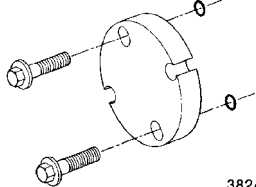
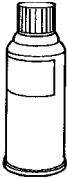
Tool No.	Tool Description	Tool Illustration
3377259	<b>Bosch® Timing Tool (VE Pump)</b> Used to time the Bosch® VE fuel pump.	
3377462	<b>Tachometer</b> Used to measure engine cranking speed.	
3399870	<b>Tamper-Resistant Screw Removal Tool</b> Used to remove tamper-resistant screw on fuel pump.	
3823425	<b>Wrench, Crowfoot</b> Used to tighten high-pressure fuel lines.	
3824469	<b>Fuel Pump Gear Puller</b> Used to pull the fuel pump gear.	
3824510	<b>QD Contact Cleaner</b> A nonpetroleum cleaner used to clean electrical connections.	

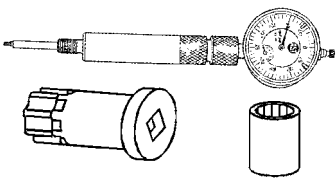
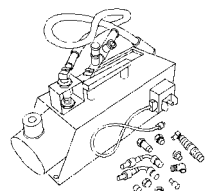
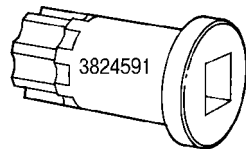
Tool No.	Tool Description	Tool Illustration
3824563	<p><b>Bosch® Lift Plunger Timing Tool (In-line pump)</b> Used to time the Bosch® in-line pump.</p>	 <p>3824563</p>
3824568	<p><b>High-Pressure Spill Port Timing Tool</b> Used to check and compare fuel pump timing to engine timing.</p>	 <p>3824568</p>
3824591	<p><b>Barring Tool</b> Used to engage the flywheel ring gear to rotate the crankshaft.</p>	 <p>3824591</p>



## Fuel System - General Information

### Fuel System Components and Flow - Distributor-Type Fuel Injection Pump

Most of the engines will be equipped with a cam actuated fuel transfer pump. Two types of fuel transfer pumps are available for distributor-type fuel injection pumps: 1) A diaphragm-style fuel transfer pump and 2) a piston-style fuel transfer pump. The piston-style fuel transfer pump is offered as an option. Fuel flow begins as the fuel transfer pump pulls fuel from the supply tank through a mandatory prefilter. The fuel transfer pump supplies low-pressure fuel to the fuel filter head, through the filter, and then to the distributor injection pump.

The distributor pump builds the high injection pressures required for combustion and routes the fuel through individual high-pressure fuel lines to each injector.

When the high-pressure fuel reaches the injector, the pressure lifts the needle valve against the spring tension to let the fuel enter the combustion chamber.

Any leakage past the needle valve enters the fuel drain manifold. The fuel drain manifold routes controlled venting from the distributor injection pump and leakage from the injectors back into the fuel tank.

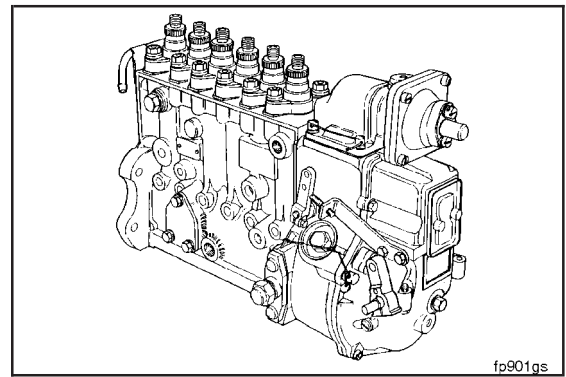

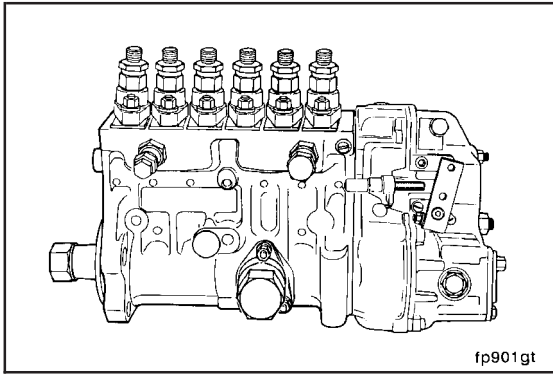

### Fuel System Components and Flow - In-Line Fuel Injection Pump

A cam-actuated piston-style fuel transfer pump provides positive fuel pressure to the fuel injection pump. Fuel flow begins as the fuel transfer pump pulls fuel from the supply tank. The system should have a prefilter or screen to remove larger contaminants from the fuel before reaching the fuel transfer pump. The fuel transfer pump supplies low-pressure fuel through the fuel filter head and filter, to the fuel injection pump.

The Bosch® in-line fuel injection pump is used on higher rated '91 and '94 B Series automotive engines and '96 marine engines. The Nippondenso EP-9 was used on pre-'96 higher horsepower marine B Series engines.

The Bosch® P3000 fuel injection pump is used on higher horsepower certified industrial engines and lower horsepower '91 to '93 automotive engines.

Bosch® "A"-type fuel injection pumps are used on lower horsepower certified industrial engines.

The fuel injection pump builds the high injection pressures required for combustion and routes the fuel through high-pressure fuel lines to each injector.

All B Series engines use closed-nozzle, hole-type injectors. When the high-pressure fuel reaches the injector, the pressure lifts the needle valve against the spring tension to allow fuel to enter the combustion chamber.

Any leakage past the needle valve enters the fuel drain manifold.

On engines equipped with the Bosch® in-line fuel injection pumps, the manifold routes leakage from the injectors to the inlet side of the fuel filter. On engines equipped with the Nippondenso EP-9 fuel injection pump, the manifold routes leakage from the injectors to the supply tank.

### Flow Diagram, Fuel System

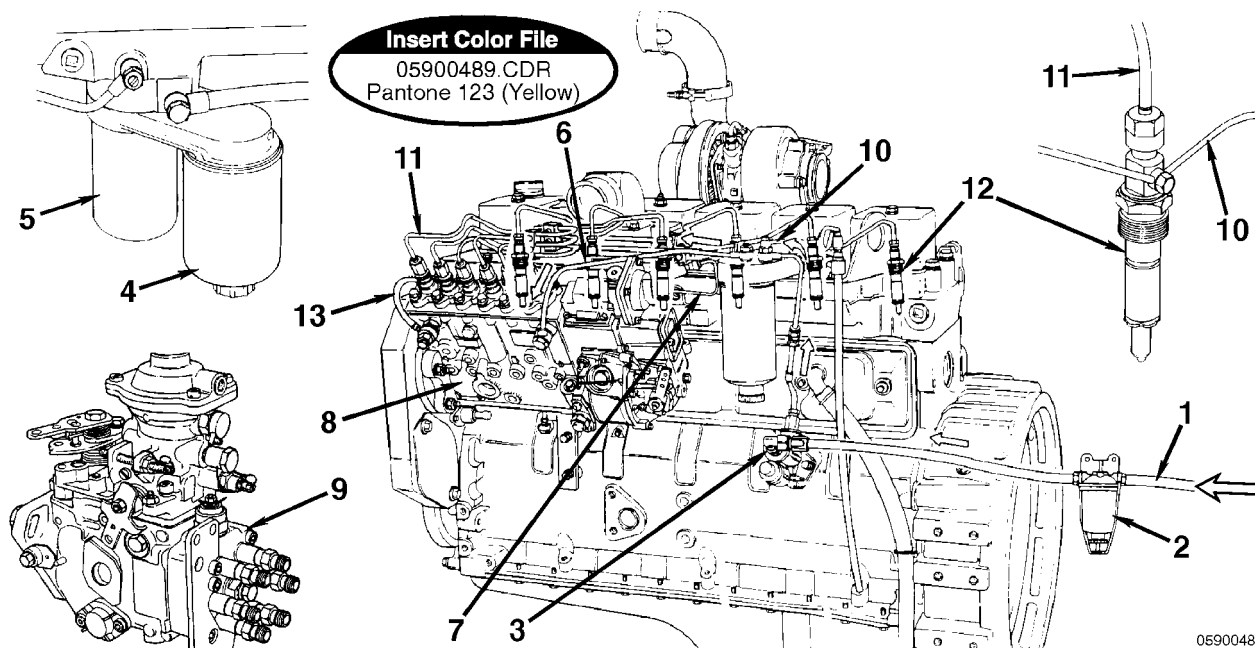

05900489

- |                                    |  |
|------------------------------------|--|
| 1. Fuel from supply tank           | 8. Bosch® P7100 injection pump                     |
| 2. Prefilter or screen             | 9. Bosch® rotary injection pump                    |
| 3. Fuel lift pump                  | 10. Fuel drain manifold                            |
| 4. Fuel/water separator            | 11. High-pressure fuel line                        |
| 5. Fuel filter                     | 12. Bosch® 7-mm closed-nozzle, hole-type injectors |
| 6. Low-pressure fuel line          | 13. Fuel return to supply tank.                    |
| 7. Turbocharger boost control line |  |

## Specifications

### Fuel System

#### Fuel System Data (automotive)

<b>Distributor-Type Fuel Injection Pumps</b>	<b>B3.9</b>	<b>B5.9</b>
Maximum Inlet Restriction to the Fuel Transfer Pump <b>Must Not</b> Exceed	100 mm Hg [4 in Hg]	100 mm Hg [4 in Hg]
Maximum Allowable Return Line Restriction	518 mm Hg [20.4 in Hg]	518 mm Hg [20.4 in Hg]
Maximum Allowable Pressure Drop across Fuel Filter	35 kPa [5 psi]	35 kPa [5 psi]
Maximum Inlet Pressure to the Injection Pump <b>Must Not</b> Exceed	70 kPa [10 psi]	70 kPa [10 psi]

<b>In-Line-Type Fuel Injection Pumps</b>	<b>B3.9</b>	<b>B5.9</b>
Maximum Inlet Restriction to the Fuel Transfer Pump <b>Must Not</b> Exceed	100 mm Hg [4 in Hg]	100 mm Hg [4 in Hg]
Fuel Transfer Pump Minimum Output Pressure	175 kPa [25 psi] @ Rated rpm	175 kPa [25 psi] @ Rated rpm
Fuel Filter Restriction (maximum pressure drop across filters)	35 kPa [5 psi]	35 kPa [5 psi]
Fuel Pressure Gallery Pressure	140 kPa [20 psi] @ Rated rpm	140 kPa [20 psi] @ Rated rpm
Fuel Return Maximum Restriction	518 mm Hg [20.4 in Hg]	518 mm Hg [20.4 in Hg]

4B Fuel System Data (nonautomotive)

Distributor-Type Fuel Injection Pumps	4B3.9	4BT3.9	4BTA3.9
Maximum Allowable Restriction to the Fuel Transfer Pump <b>Must Not Exceed</b>	100 mm Hg [4 in Hg]	100 mm Hg [4 in Hg]	100 mm Hg [4 in Hg]
Maximum Allowable Return Line Restriction	518 mm Hg [20.4 in Hg]	518 mm Hg [20.4 in Hg]	518 mm Hg [20.4 in Hg]
Maximum Allowable Pressure Drop across Fuel Filter	35 kPa [5 psi]	35 kPa [5 psi]	35 kPa [5 psi]
Maximum Inlet Pressure to the Injection Pump <b>Must Not Exceed</b>	70 kPa [10 psi]	70 kPa [10 psi]	70 kPa [10 psi]
<b>In-Line-Type Fuel Injection Pumps</b>			
Maximum Inlet Restriction to the Fuel Transfer Pump <b>Must Not Exceed</b>	100 mm Hg [4 in Hg]	100 mm Hg [4 in Hg]	100 mm Hg [4 in Hg]
Fuel Transfer Pump Minimum Output Pressure	172 kPa [25 psi] High Flow and 90 kPa [13 psi] Low Flow @ Rated rpm	172 kPa [25 psi] High Flow and 90 kPa [13 psi] Low Flow @ Rated rpm	172 kPa [25 psi] High Flow and 90 kPa [13 psi] Low Flow @ Rated rpm
Fuel Filter Restriction (maximum pressure drop across filters)	35 kPa [5 psi]	35 kPa [5 psi]	35 kPa [5 psi]
Fuel Pump Gallery Pressure	* 140 kPa [20 psi] @ Rated rpm	* 140 kPa [20 psi] @ Rated rpm	* 140 kPa [20 psi] @ Rated rpm
Fuel Return Maximum Restriction	518 mm Hg [20.4 in Hg]	518 mm Hg [20.4 in Hg]	518 mm Hg [20.4 in Hg]

\* The low-flow fuel transfer pump will have 82.7 kPa [12 psi].

6B Fuel System Data (nonautomotive)

Distributor-Type of Fuel Injection Pumps	6B5.9	6BT5.9	6BTA5.9
Maximum Allowable Restriction to the Fuel Transfer Pump <b>Must Not Exceed</b>	100 mm Hg [4 in Hg]	100 mm Hg [4 in Hg]	100 mm Hg [4 in Hg]
Maximum Allowable Return Line Restriction	518 mm Hg [20.4 in Hg]	518 mm Hg [20.4 in Hg]	518 mm Hg [20.4 in Hg]
Maximum Allowable Pressure Drop across Fuel Filter	35 kPa [5 psi]	35 kPa [5 psi]	35 kPa [5 psi]
Maximum Inlet Pressure to the Injection Pump <b>Must Not Exceed</b>	70 kPa [10 psi]	70 kPa [10 psi]	70 kPa [10 psi]
<b>In-Line-Type Fuel of Injection Pumps</b>			
Maximum Inlet Restriction to the Fuel Transfer Pump <b>Must Not Exceed</b>	100 mm Hg [4 in Hg]	100 mm Hg [4 in Hg]	100 mm Hg [4 in Hg]
Fuel Transfer Pump Minimum Output Pressure	172 kPa [25 psi] High Flow and 90 kPa [13 psi] Low Flow @ Rated rpm	172 kPa [25 psi] High Flow and 90 kPa [13 psi] Low Flow @ Rated rpm	172 kPa [25 psi] High Flow and 90 kPa [13 psi] Low Flow @ Rated rpm
Fuel Filter Restriction (maximum pressure drop across filters)	35 kPa [5 psi]	35 kPa [5 psi]	35 kPa [5 psi]
Fuel Pump Gallery Pressure	* 140 kPa [20 psi] @ Rated rpm	* 140 kPa [20 psi] @ Rated rpm	* 140 kPa [20 psi] @ Rated rpm
Fuel Return Maximum Restriction	518 mm Hg [20.4 in Hg]	518 mm Hg [20.4 in Hg]	518 mm Hg [20.4 in Hg]

\* The low-flow fuel transfer pump will have 82.7 kPa [12 psi].

## Fuel Recommendations and Specifications

### Fuel Recommendations



Do not mix gasoline, alcohol, or gasohol with diesel fuel. This mixture can cause an explosion.



Due to the precise tolerances of diesel injection systems, it is extremely important that the fuel be kept clean and free of dirt or water. Dirt or water in the system can cause severe damage to both the fuel pump and the fuel injectors.

Cummins Engine Company, Inc. recommends the use of ASTM No. 2D fuel. The use of No. 2 diesel fuel will result in optimum engine performance.

At operating temperatures below 0°C [32°F], acceptable performance can be obtained by using blends of No. 2D and No. 1D.

**NOTE:** Lighter fuels can reduce fuel economy or possibly damage the fuel injection pump.

The viscosity of the fuel **must** be kept above 1.3 cSt at 40°C [104°F] to provide adequate fuel system lubrication.

The following chart lists acceptable alternate fuels for B Series engines.

Acceptable Substitute Fuels - Cummins B Fuel System									
No. 1D Diesel <sup>(1)</sup> (2)	No. 2D Diesel <sup>(3)</sup>	No. 1K Kerosene	Jet-A	Jet-A1	JP-5	JP-8	Jet-B	JP-4	CITE
A	OK	A	A	A	A	A	NOT OK	NOT OK	NOTOK

1. An "A" means OK **only** if fuel lubricity is adequate. This means the BOCLE number is 3100 or greater as measured with the US Army scuffing BOCLE test.

2. Any adjustment to compensate for reduced performance with a fuel system using alternate fuel is **not** warrantable.

3. Winter blend fuels, such as found at commercial fuel dispensing outlets, are combinations of No. 1D and No. 2D diesel fuel, and are acceptable.

Additional information for fuel recommendations and specifications can be found in Fuel for Cummins Engines, Bulletin No. 3379001. See ordering information in the back of this manual.

## AFC Assembly (005-001)

### General Information

#### Air-Fuel Control (AFC) Malfunctions

The RQVK governors are equipped with an air-fuel control (AFC) device to help control emissions. The AFC regulates the fuel-to-air mixture by sensing manifold pressure. A malfunction of the AFC can cause low power or excessive exhaust smoke under load. Leaks at the fittings or a restriction in the tube from the intake manifold to the AFC can also cause low power.

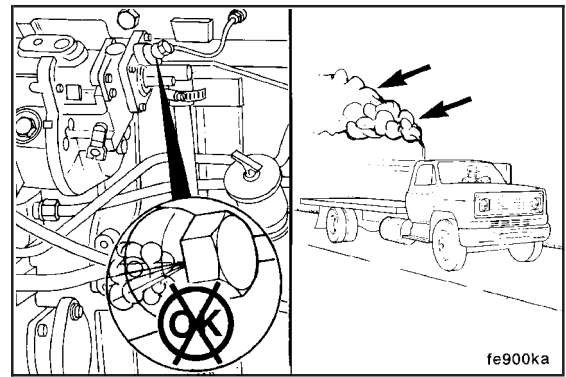

## Engine Fuel Heater, Electric (005-008)

### Initial Check (005-008-001)

**NOTE:** The fuel heater is not controlled by the electronic control module (ECM). A bimetallic strip on the filter head acts as a thermostat. The fuel heater will turn on at approximately 1°C [34°F] and turn off at approximately 18°C [64°F].

Remove the 2-pin connector from the fuel heater.

Using an ohmmeter, check the continuity of the fuel heater by placing the ohmmeter test leads across the pins of the fuel heater.

If the heater circuit is open, replace the fuel heater.

Check for proper voltage to the fuel heater.

<b>Minimum Voltage</b>
12 VDC

If voltage is **not** within specifications, refer to the OEM service manual.

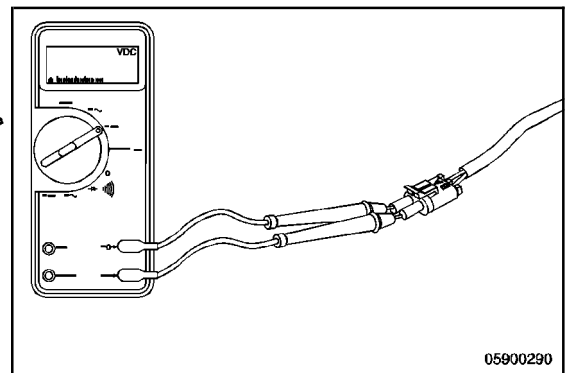
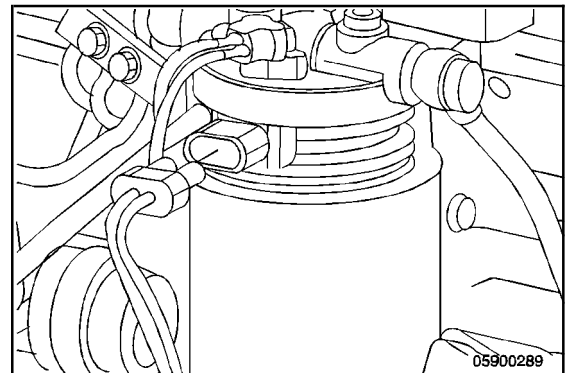

### Remove (005-008-002)

Disconnect the connector from the fuel heater.

Disconnect the connector from the water-in-fuel (WIF) sensor.

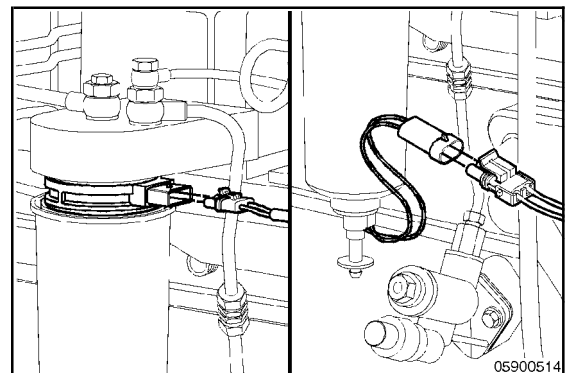

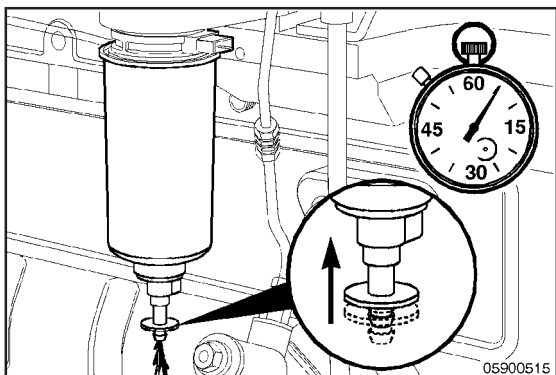

Push on the fuel drain valve for approximately 5 seconds to reduce fuel spillage during filter removal.

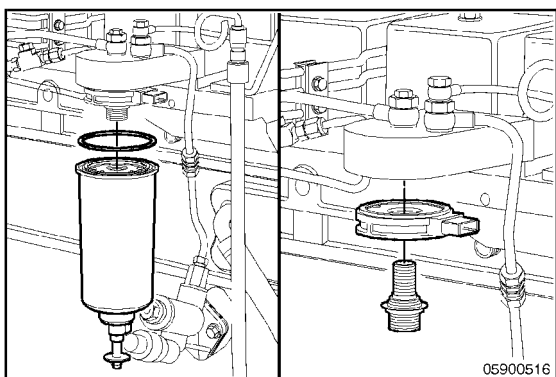

Remove the fuel filter.  
Remove the fuel filter spud.  
Remove the fuel heater from the filter head. The heater should be able to be pulled off the filter head.

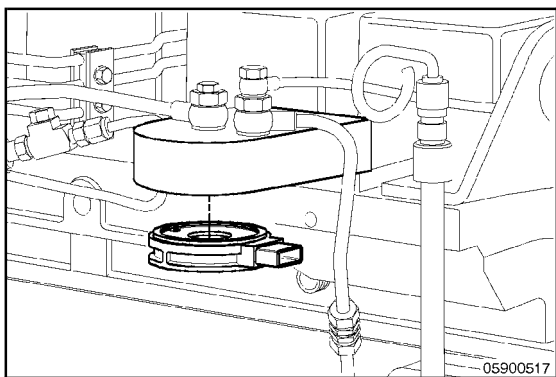

**Install (005-008-026)**  
Place the fuel heater, gasket side facing up, against the filter head.

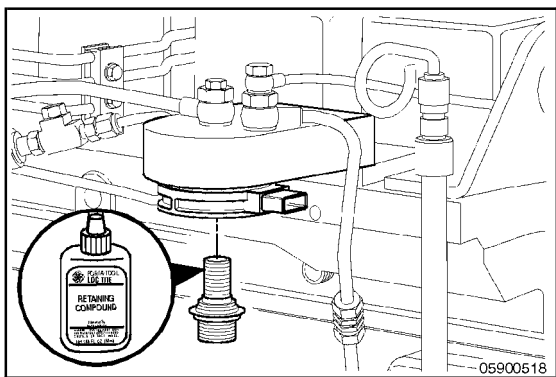

Apply Loctite to the filter spud.  
Install the fuel filter spud.  
**Torque Value:** 41 N•m [30 ft-lb]  
**Torque Value:** 27 N•m [20 ft-lb]





Install an o-ring between the fuel heater and the filter canister.

Install the fuel filter.

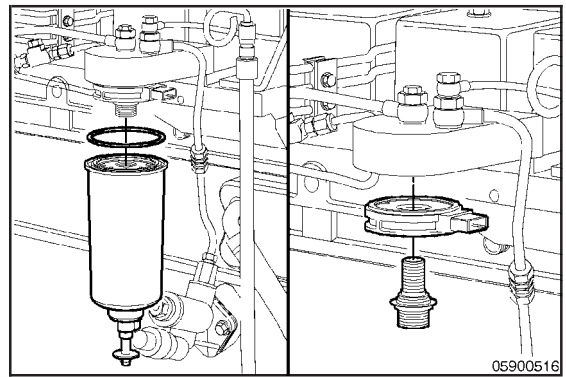

Connect the connector to the water-in-fuel sensor.

Connect the connector to the fuel heater.

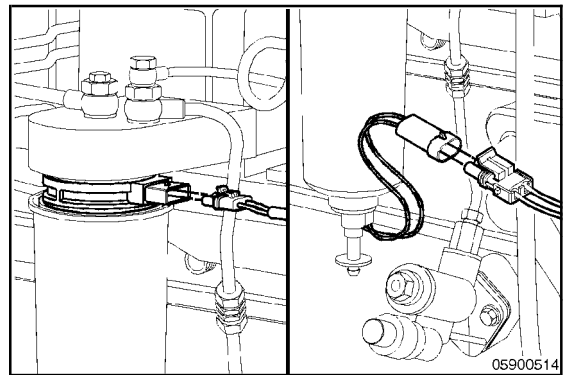

## Fuel Consumption (005-010)

### Measure (005-010-010)

Refer to the fuel consumption checklist sheets in the back of Section TS.

**NOTE:** The most accurate method to check the fuel consumption is to weigh the fuel used. Use a scale capable of measuring within 0.045 kg [0.1 lb] to weigh the fuel tank. Use a remote-mount tank with enough capacity to run 80 km [50 mi].

Fill the fuel tank. Weigh the tank with the fuel. The weight on No. 2 diesel fuel is nominally 0.844 kg per liter [7.03 pounds per gallon].

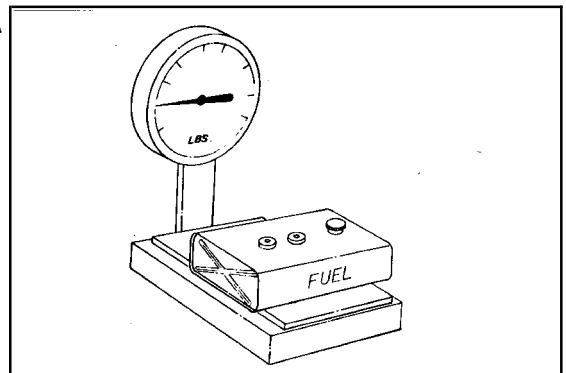

Install the remote tank (1).

Install the return fuel line to the test tank, or the results will **not** be accurate.

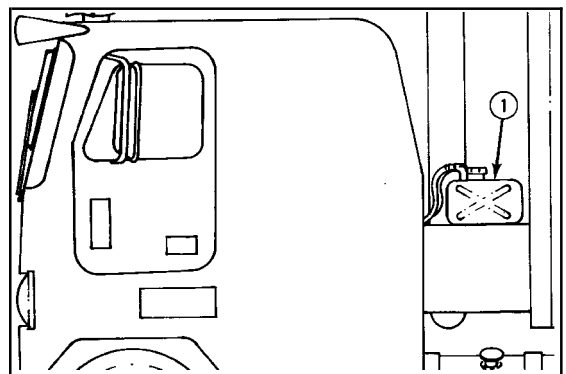

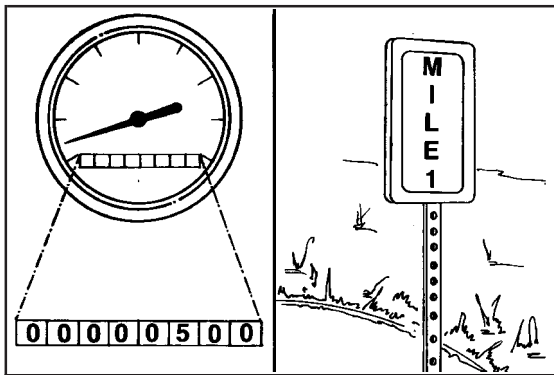

Measure the distance traveled with an accurate odometer. The odometer accuracy can be checked by using measured kilometers [miles].

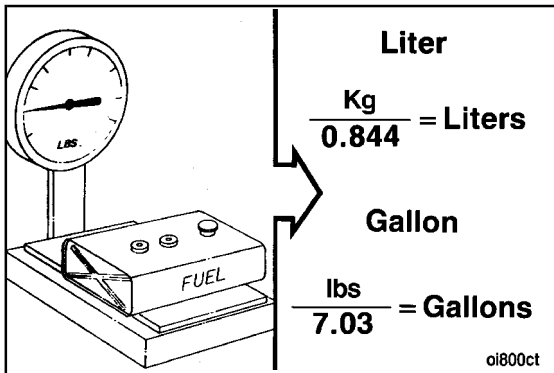

After traveling the route, remove the tanks, and weigh the remaining fuel. Compute the fuel used in liters [gallons] as required.

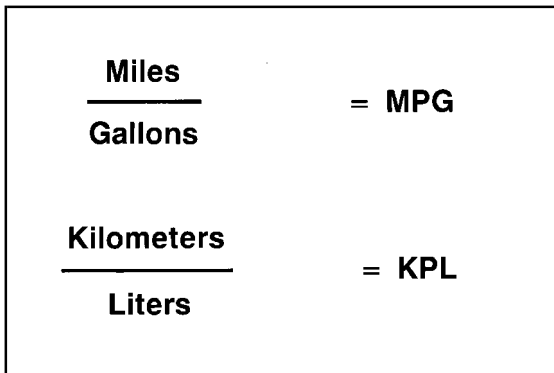

Compute the kilometers per liter or miles per gallon.

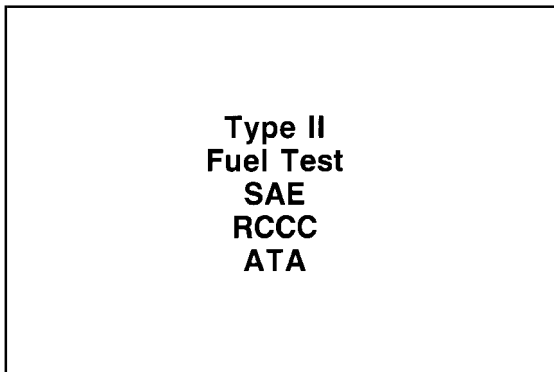

In addition to the measurement of the fuel used, the following factors provide points for running a test similar to the recognized Type II Society of Automotive Engineers Fuel Test.

These procedures are helpful to determine differences in fuel consumption between two vehicles under the same environmental, road, and test conditions.

Perform the test with the test vehicle and a control vehicle. The control vehicle compensates for changes in traffic conditions.

The vehicles **must** stay close together to experience the same varying traffic and weather conditions, but **not** so close as to affect each other's driving or headwind.

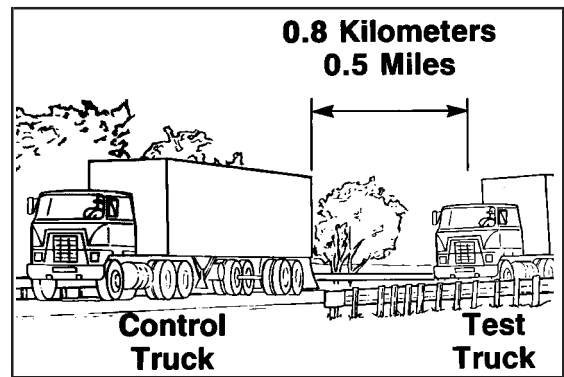

The test course **must** be 65 to 80 km [40 to 50 mi] long.

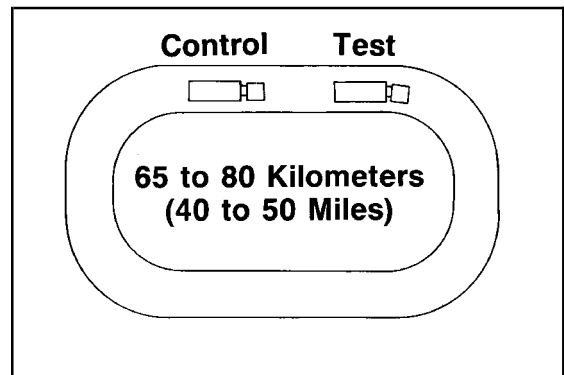

The test route and truck weights **must not** change during the test.

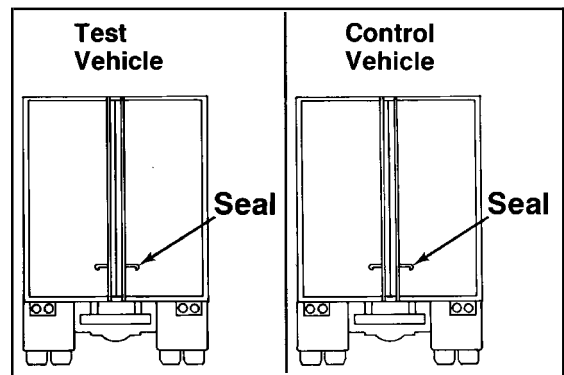

All of the test results are based on comparing the fuel used by the test truck to the fuel used by the control truck.

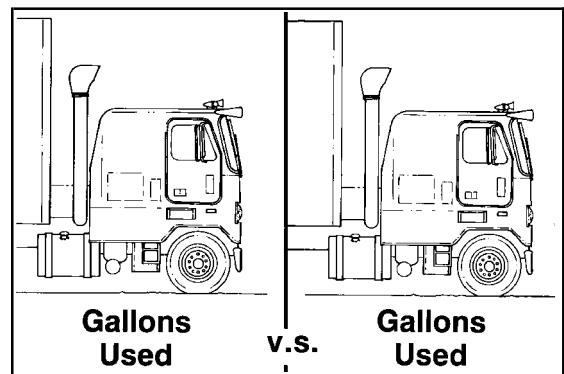

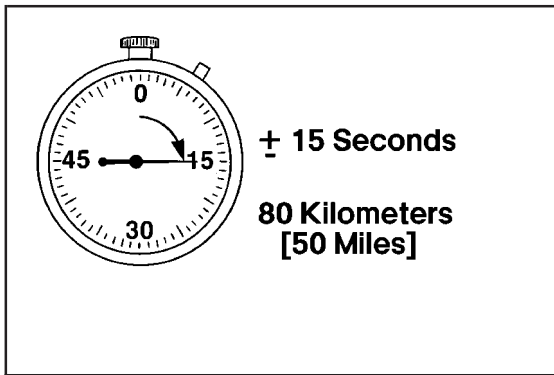

Drive the truck on a warm-up test run. Drive enough tests to achieve:

Difference in elapsed time between each test run can **only** be plus or minus 0.5 percent. This will be ± 15 seconds on 80 km [50 mi] at 60 miles per hour.

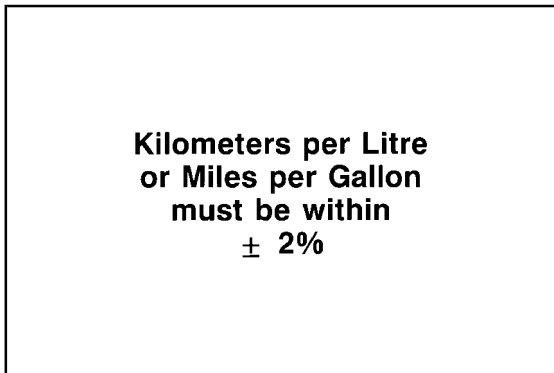

The fuel usage of the test truck between test drives **must** fall within a 2-percent range, e.g., 2.55 vs. 2.60 km/l [6.00 vs. 6.12 mpg].

The same range also applies between drives of the control truck.

**NOTE:** The differences in traffic and driving practices can make the test drive fall out of the 2-percent range.

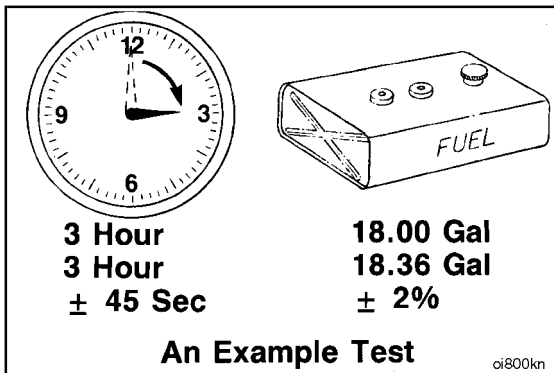

A minimum of three test drives that meet these conditions make a valid test. A single test drive is unreliable.

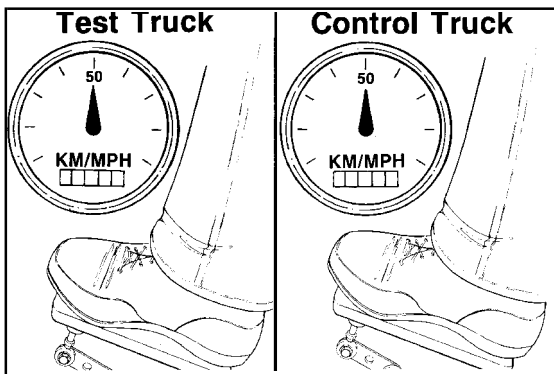

Use the same experienced drivers for all of the tests.

**NOTE:** The vehicle speeds **must** be representative of a typical operation.

During the test, record the following:

- Ambient temperature
- Humidity
- Barometric pressure
- Wind velocity
- Wind direction.

**NOTE:** Avoid testing under any extreme conditions.

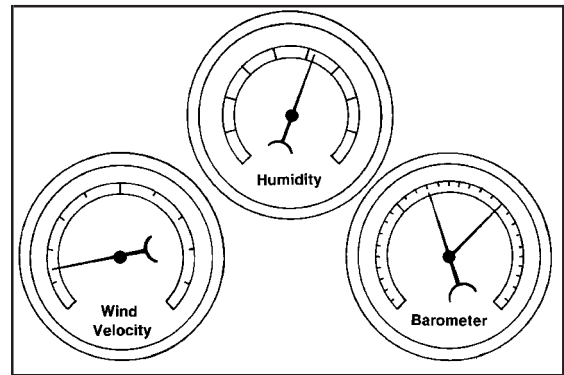

**Fuel Flow (005-011)**

**Pressure Test (005-011-013)**

Inspect to determine if the fuel transfer pump is delivering fuel. Measure the output pressure at the inlet of the injection pump.

Fuel Transfer Pump Output Pressure at Rated Speed			
	kPa		psi
High-flow-automotive	172	MIN	25
Low-flow-industrial	83	MIN	12

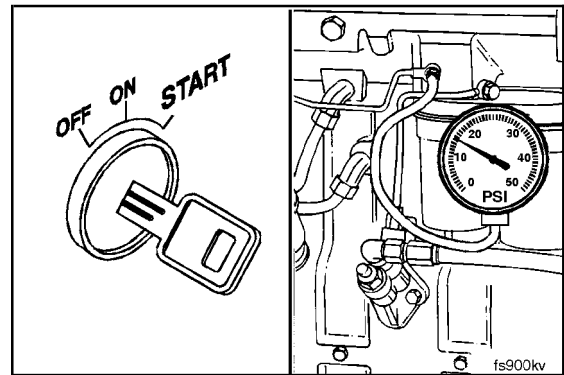

If the required volume is **not** being delivered, measure the transfer pump inlet restriction with a vacuum gauge between the transfer pump inlet and the supply line (4) from the fuel tank.

Fuel Transfer Pump Inlet Restriction		
kPa		in Hg
13.55	MAX	4

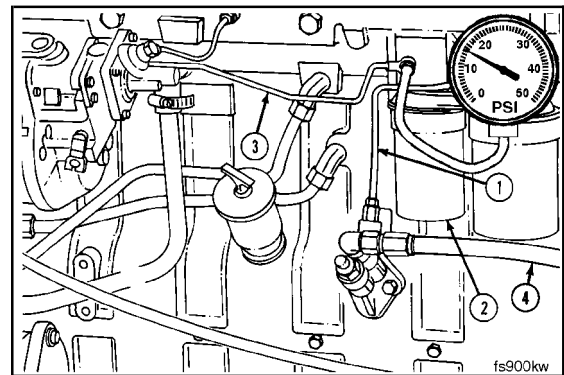

**NOTE:** Frequent fuel filter replacement to get full power from the engine can indicate a worn fuel lift pump.

The pressure drop across the filter(s) will increase as the filter removes contaminants from the fuel. A worn fuel lift pump will have reduced capacity to force fuel through a dirty filter. This can cause low engine power.

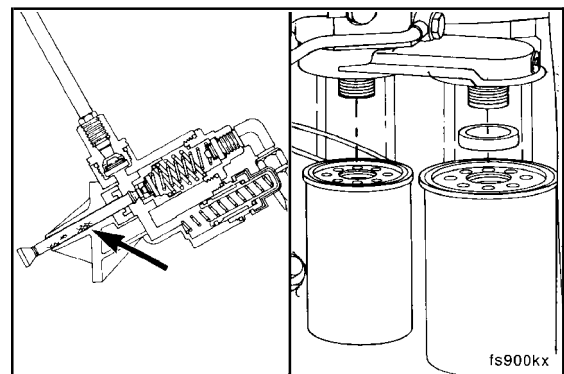

If the fuel is aerated or the volume is low, isolate the fuel transfer pump by connecting the fuel transfer pump inlet to a temporary supply, and perform the same check as above.

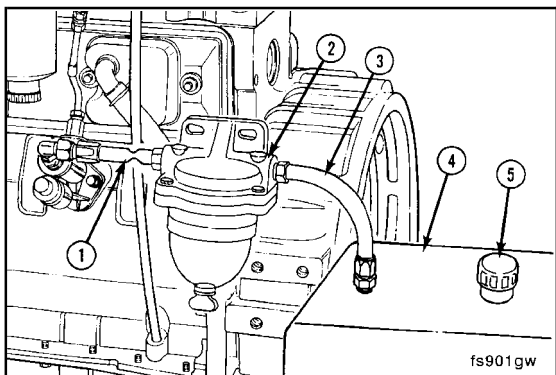
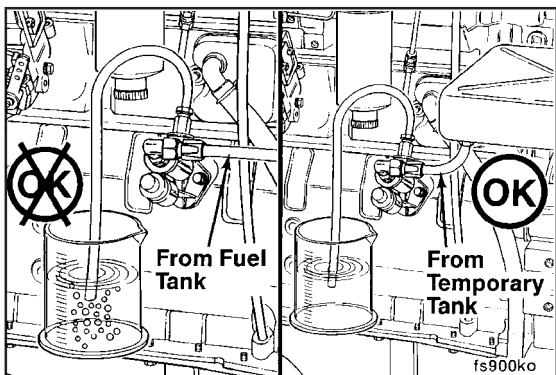

If the fuel transfer pump delivers the required volume of fuel from a temporary supply, check for restrictions or suction leaks in the fuel circuit to the fuel transfer pump:

1. Supply line
2. Prefilter
3. Supply line
4. Supply tank
5. Tank vent.

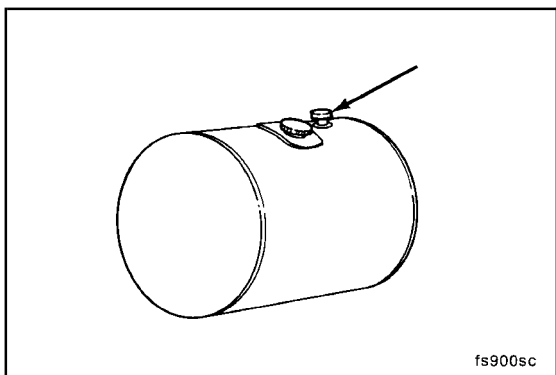

Check for a plugged supply tank vent first.

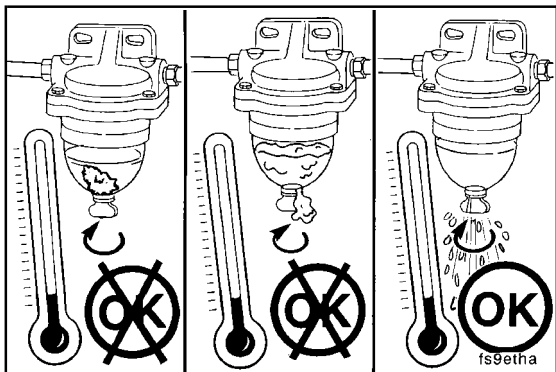

In cold weather check for gelled diesel fuel blocking the prefilter.

Clean or replace the prefilter.

**▲ WARNING ▲**

Wear appropriate eye and face protection when using compressed air. Flying debris and dirt can cause bodily injury.

Inspect the fuel supply lines for restrictions.

Remove and blow out the fuel supply lines with compressed air, if necessary.

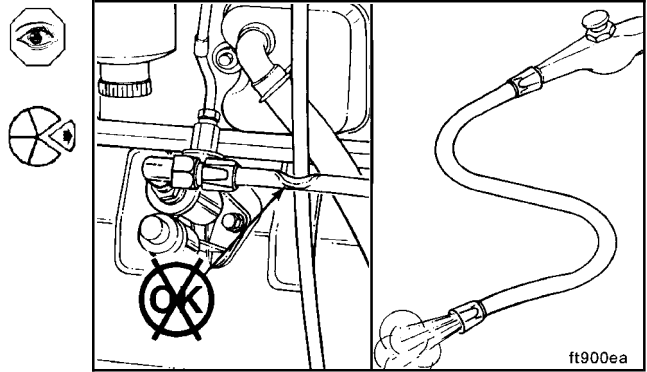

**Fuel Injection Pumps, In-Line (005-012)**

**General Information**

The Bosch® P7100 in-line fuel injection pump can be found on the following engine application:

- 1991 high-horsepower automotive ratings
- 1994 automotive, all 6B ratings
- 1996 emissionized high-horsepower industrial ratings.

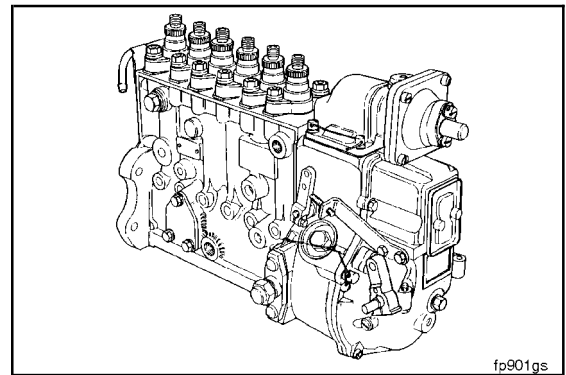

The Nippondenso EP-9 in-line fuel injection pump with the RSV governor can be found on the following engine application:

- Higher horsepower marine rating.

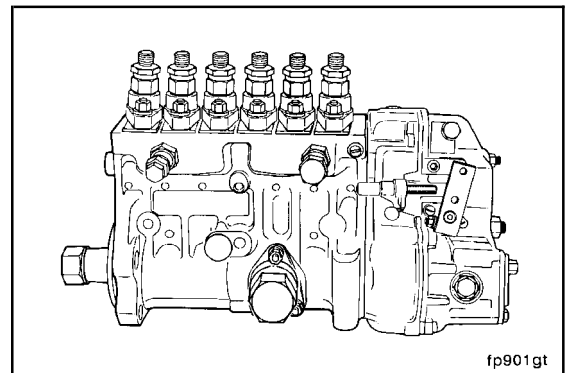

The Bosch® A-RSV in-line fuel injection pump can be found on the following engine application:

- Pre-1996 noncommissioned industrial ratings
- 1996 industrial emission ratings
- Marine
- Gensets.

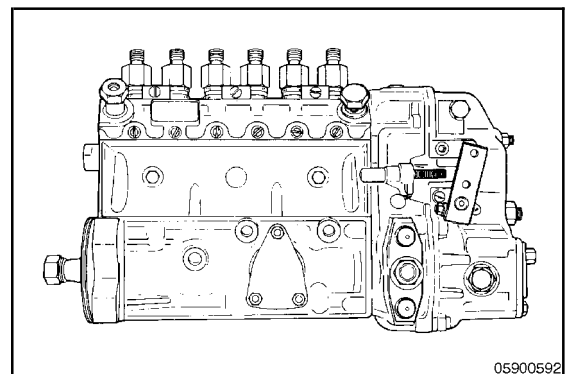

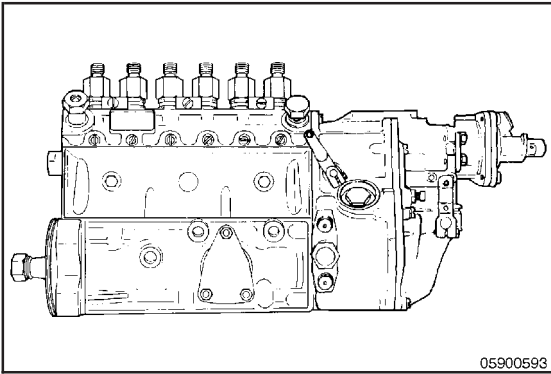

The Bosch® MW/RSV and MW/RQV in-line fuel injection pump can be found on the following engine application:

- 1996 and higher industrial emission ratings.

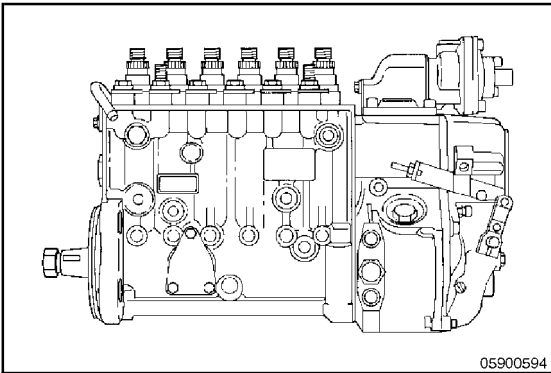

The Bosch® P3000/RQVK and P3000/RQV in-line fuel injection pump.

- 1996 and higher high-horsepower industrial emission rating.

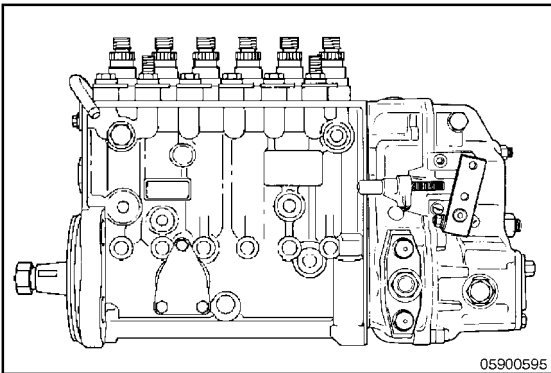

The Bosch® P3000/RSV In-line fuel injection pump.

- 1996 and higher high-horsepower industrial emission ratings
- Marine.

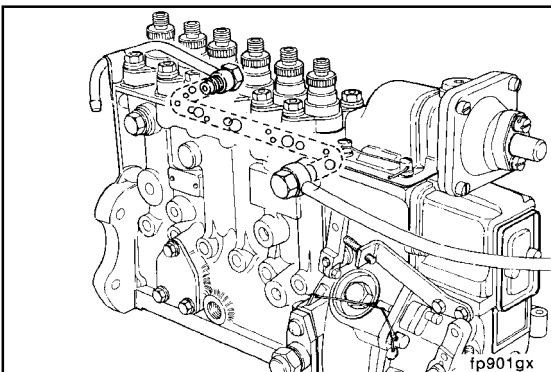

The pressure relief valve arrangement on the Bosch® P7100 fuel injection pump in the supply side of the fuel circuit creates a self-bleeding system for air introduced during replacement of the supply-side components.

Small amounts of air can be bled from the pump by operating the hand primer on the fuel transfer pump or by cranking the engine.



**B3.9 and B5.9 Series Engines  
Section 5 - Fuel System - Group 05**

The Bosch® P7100 in-line fuel injection pump has a jump-over tube to route return fuel and entrapped air from the pressure relief valve directly to the supply tank.

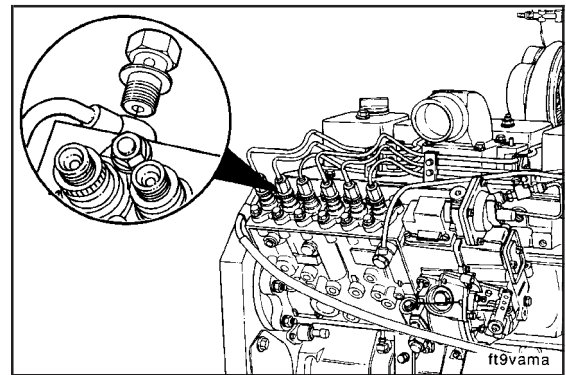

The Nippondenso EP-9 in-line fuel injection pumps will require additional venting prior to initial start-up, pump replacement, or if engine fuel runs out.

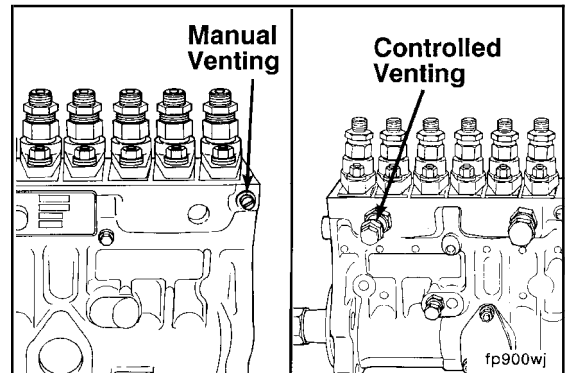

**Fuel Injection Pump (In-Line Type)**

Beginning in 1991, the B Series engine used the Bosch® P7100 in-line fuel injection pump on higher horsepower automotive ratings. In 1994, all automotive 6B Series engines used the Bosch® P-7100 in-line fuel injection pump.

B Series industrial ratings and marine (after 1996) engines use the Bosch® "A" in-line fuel injection pumps.

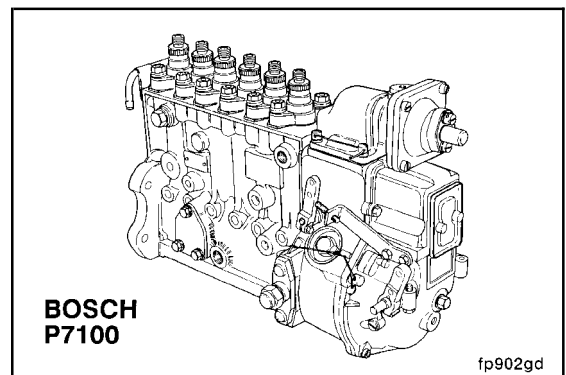

The B Series engine also uses the Nippondenso EP-9 with RSV governor on 1996 or earlier engines with a 250 and 300-horsepower marine rating.



Refer to the B Series Marine Operation and Maintenance Manual, Bulletin No. 3810466, for additional information.

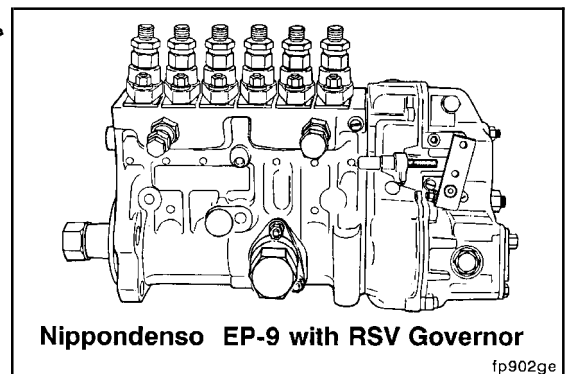

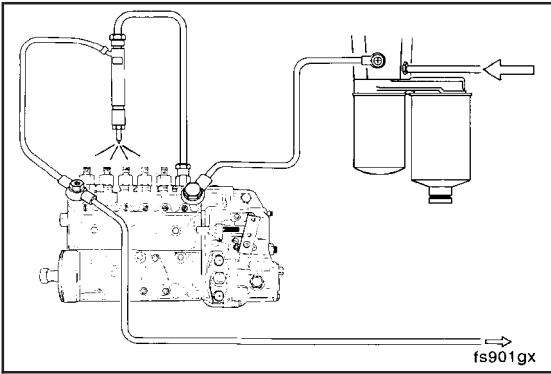

The fuel injection pump performs the three basic functions of:

1. Metering the exact amount of fuel for each injection cycle
2. Producing the high fuel pressure required for injection
3. Delivering the high-pressure metered fuel to each cylinder at the precise time.

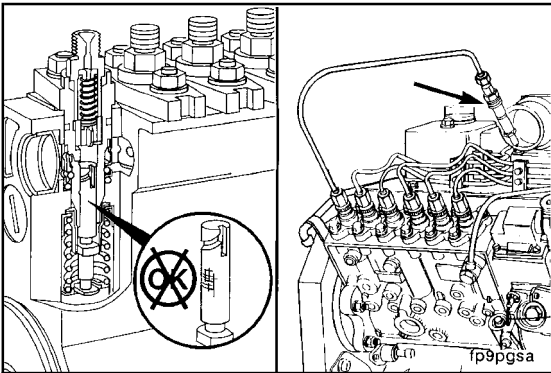

Individual plungers are used in the pumps to develop and distribute the high pressure required for injection.

A worn or damaged plunger in the pump will affect **only** one cylinder.

**Preparatory (005-012-000)**

- Clean any debris.
- Disconnect all fuel lines to the pump.
- Remove control linkage.
- Disconnect AFC tube (where applicable).
- Disconnect wastegate turbocharger control line (where applicable).

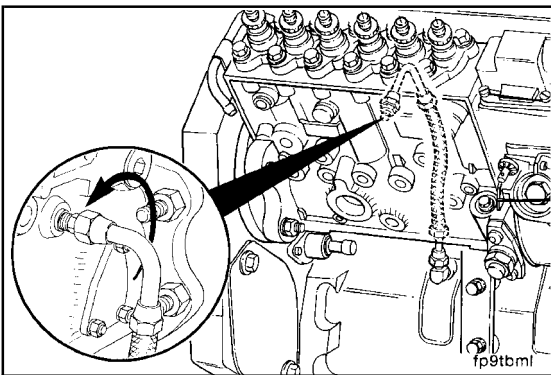

**Remove (005-012-002)**

9/16 Inch



Disconnect the external oil feed line at the inboard side of the fuel injection pump (if applicable) and the main oil rifle.

Disconnect the external oil feed line at the rear of the pump or AFC latchout if applicable.

**B3.9 and B5.9 Series Engines  
Section 5 - Fuel System - Group 05**

Locate top dead center (TDC) for cylinder No. 1. Push the TDC pin into the hole in the camshaft gear while slowly barring the engine.

**NOTE:** Be sure to disengage the timing pin after locating TDC.

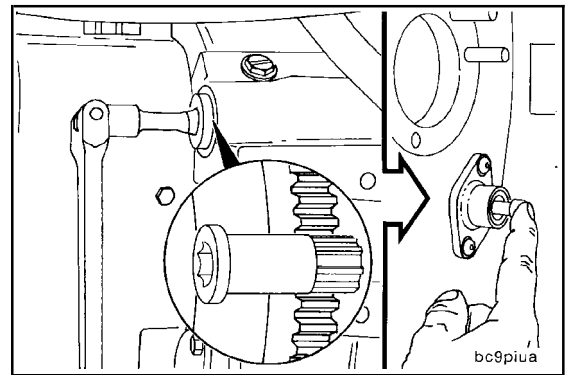

**10 mm**

Remove the fuel injection pump mounting bracket, if applicable.

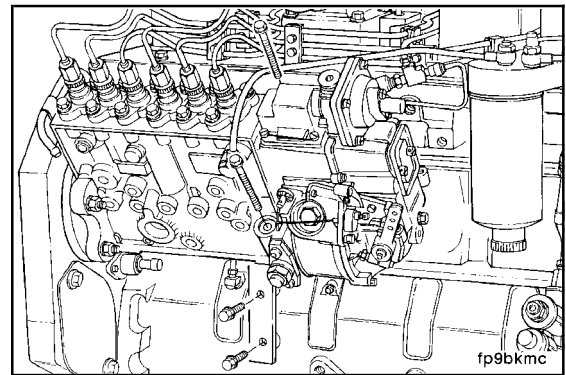

**⚠ CAUTION ⚠**

**Do not drop the nut and washer. Dropping the nut and washer will result in the need to remove the front cover.**

**30 mm**

Remove the gear cover access cap.

Remove the nut and washer from the fuel injection pump shaft.

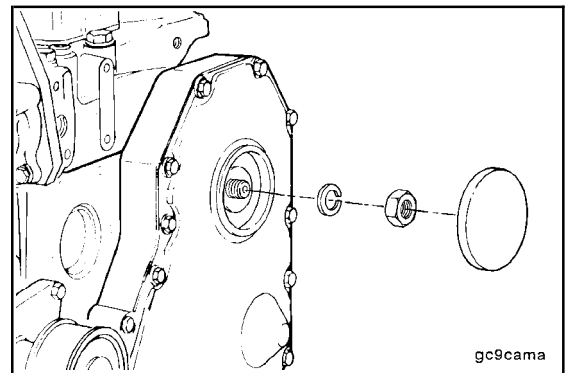

**T-Bar Puller**

Pull the fuel injection pump drive gear loose from the shaft.

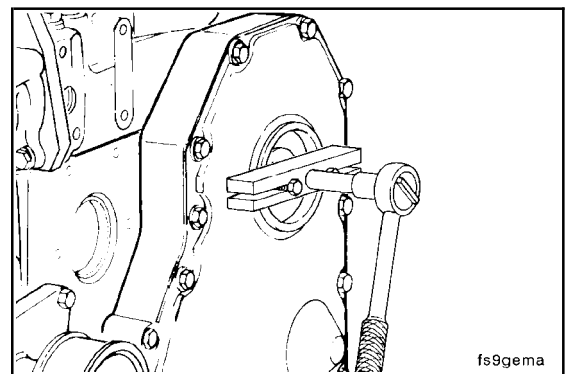

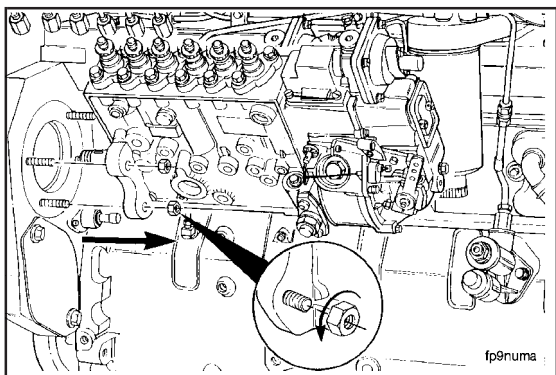

15 mm

Remove the four mounting nuts.



Remove the fuel injection pump.

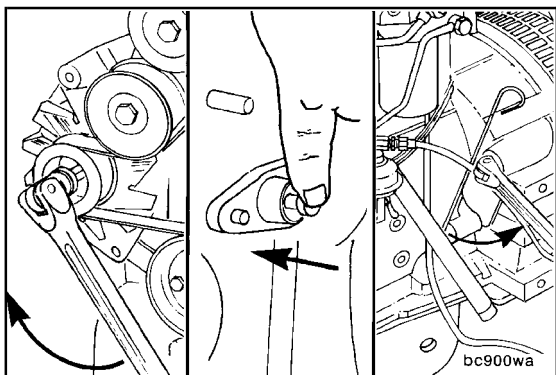

**Install (005-012-026)**

Make sure the engine has cylinder No. 1 at top dead center (TDC).

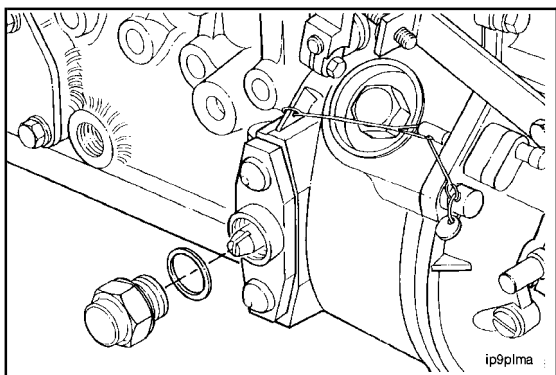

24 mm

Remove the access plug.

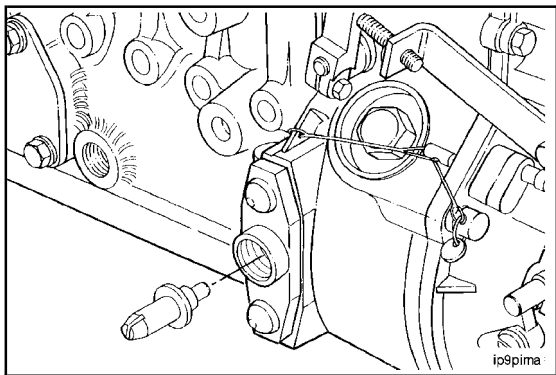

Remove the timing pin.

If the timing tooth is **not** aligned with the timing pin hole, rotate the fuel injection pump shaft until the timing tooth aligns.

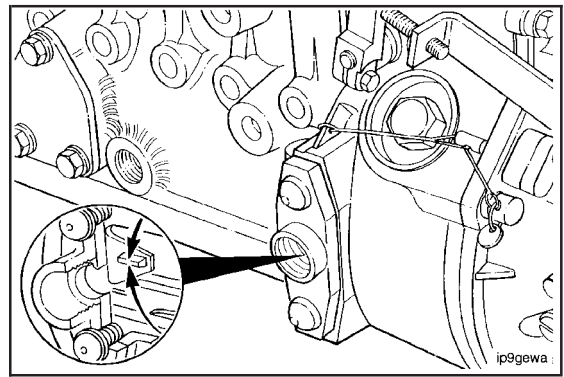

Reverse the position of the timing pin so the slot of the timing pin will fit over the timing tooth in the pump.

Install and secure the timing pin with the access plug.

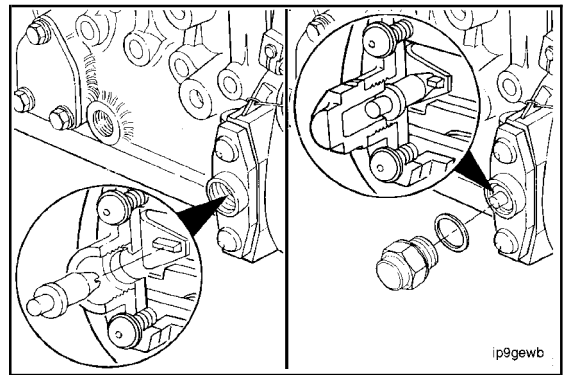

Use a 50/50 mixture of clean lubricating engine oil and STP, or equivalent, to lubricate the gear cover housing to be sure the fuel injection pump will slide into the gear cover housing easily.

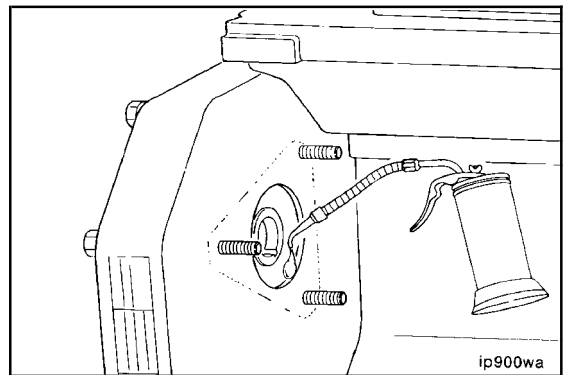

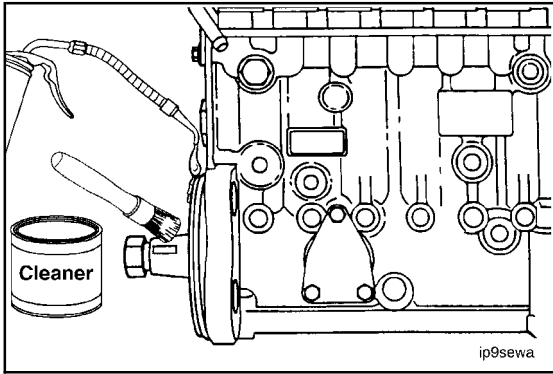

**▲ WARNING ▲**

When using solvents, acids, or alkaline materials for cleaning, follow the manufacturer's recommendations for use. Wear goggles and protective clothing to avoid personal injury.

**▲ WARNING ▲**

Wear appropriate eye and face protection when using compressed air. Flying debris and dirt can cause bodily injury.

**▲ CAUTION ▲**

The fuel injection pump drive gear inside diameter and the shaft outside diameter must be clean and dry before installing the gear. Failure to do so can result in slipped timing.

**QD Contact Cleaner, Part No. 3824510**

**NOTE:** Before installing the fuel pump drive gear, clean the injection pump shaft and gear tapers with residue-free cleaner, Part No. 3824510, by spraying into the gap between the shaft and the gear. Dry with compressed air.

**NOTE:** The in-line fuel injection pump driveshaft has a provision for a Woodruff key; however, it is **not** required. Timing mark alignment is **not** required for the in-line drive gear.

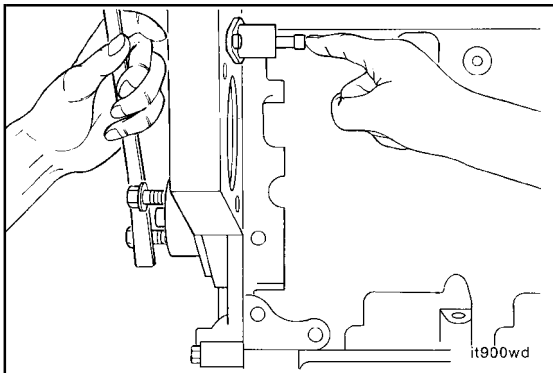

**NOTE:** Make sure the engine has cylinder No. 1 at TDC.

Make sure the o-ring seals for the fill orifice (A) and pilot (B) are correctly installed and are **not** damaged.

Install new pilot o-ring.

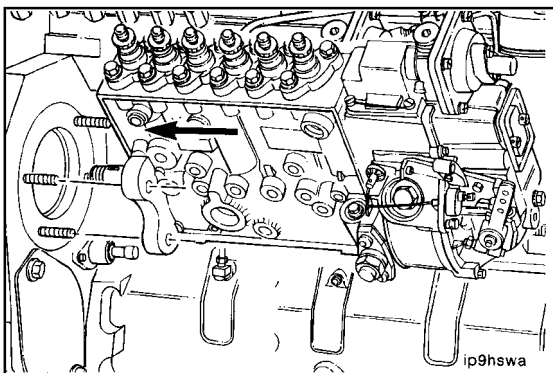

Slide the pump shaft through the drive gear and position the pump flange onto the mounting studs.

Push the pump forward until the mounting flange and o-ring are properly fitted into the gear housing bore.

**⚠ CAUTION ⚠**

Do not attempt to pull the pump flange into the gear housing with the mounting nuts as damage to housing can occur.

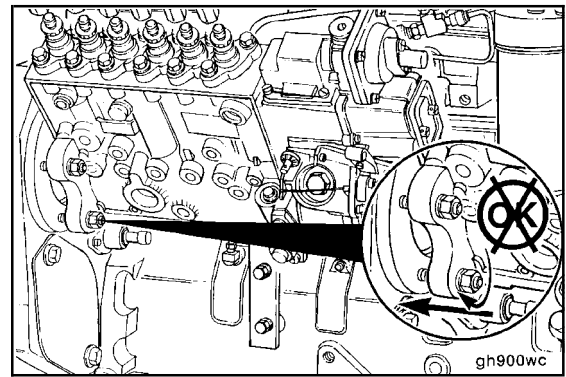

15 mm

Install the mounting nuts.

**Torque Value:** 43 N•m [32 ft-lb]

Install the support bracket (if equipped).

**Torque Value:** 32 N•m [24 ft-lb]

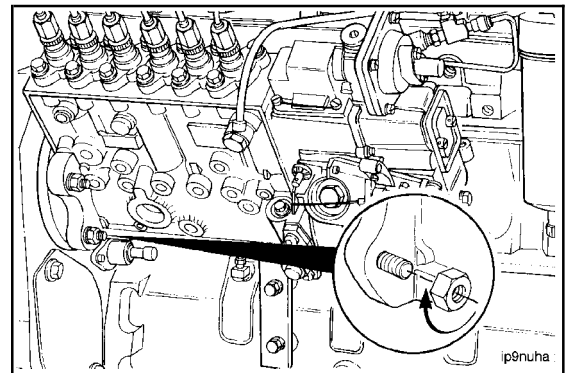

**⚠ CAUTION ⚠**

Do not drop the nut and washer. Dropping the nut and washer will result in the need to remove the front cover.

30 mm

Install the retaining nut and washer.

**Torque Value:** 10 to 15 N•m [89 to 133 in-lb]

To prevent damage to the timing pins, do **not** exceed the torque value given. This is **not** the final torque value for the retaining nut.

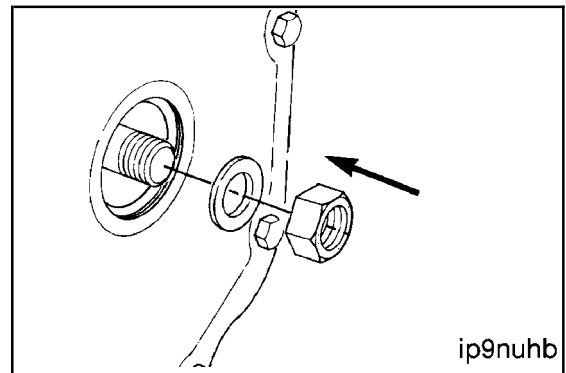

Disengage the engine timing pin.

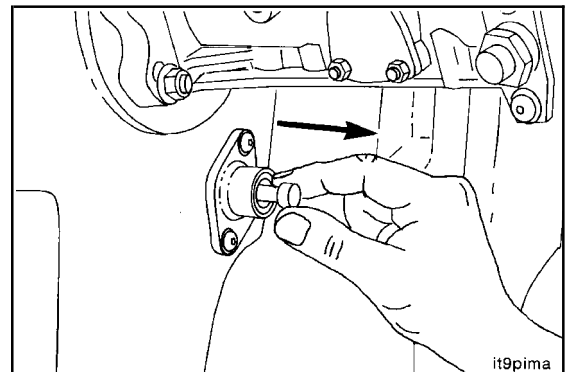

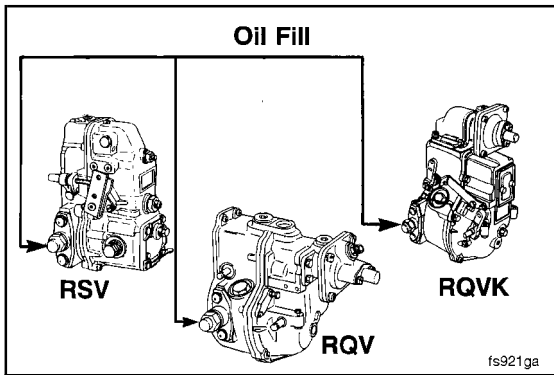

**CAUTION**

The governor housing must be prelubricated before engine operation. Failure to do so can result in premature governor wear.

Remove the access plug.

Add the following quantity of clean lubricating engine oil:

- RSV 450 mL [0.48 qt]
- RQV 750 mL [0.79 qt]
- RQVK 750 mL [0.79 qt]

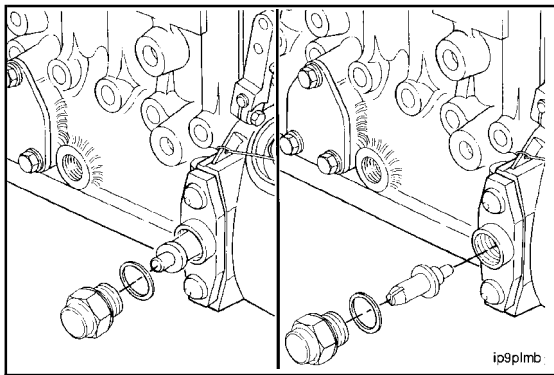

**24 mm**

Remove the fuel injection pump timing pin plug, reverse the position of the timing pin, and install the timing pin, plug, and sealing washer.



**Torque Value:** 27 N•m [20 ft-lb]

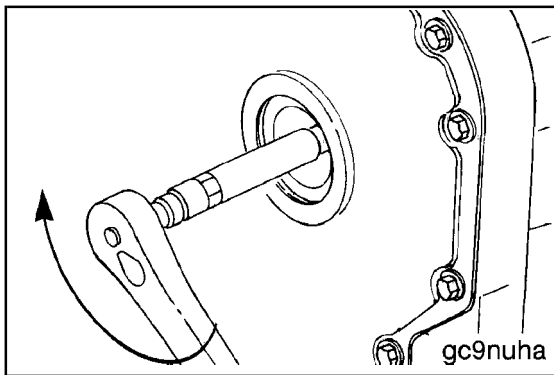

**30 mm**

Tighten the fuel injection pump drive nut.



**Torque Value:**

"A" Pump	85 N•m	[63 ft-lb]
P3000/P7100	195 N•m	[144 ft-lb]
Nippondenso	123 N•m	[91 ft-lb]



Install the gear cover access cap hand-tight.

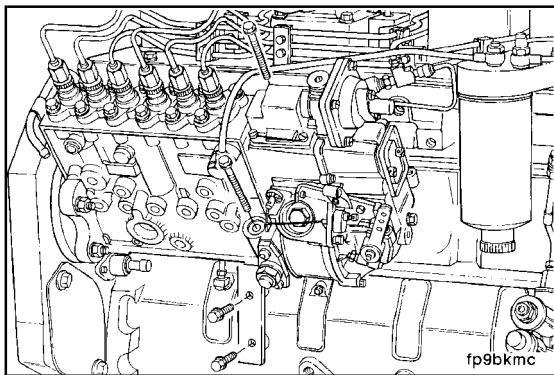

**10 mm**

Install the fuel injection pump mounting bracket capscrews.

Tighten all capscrews by hand for proper alignment.



**Torque Value:** 24 N•m [18 ft-lb]





**B3.9 and B5.9 Series Engines  
Section 5 - Fuel System - Group 05**

Install the fuel lines, AFC line, control linkage, and turbo-charger wastegate line.

**Torque Value:**

High-Pressure Fuel Lines	30 N•m	[22 ft-lb]
Low-Pressure Fuel Supply Fitting	15 N•m	[133 in-lb]

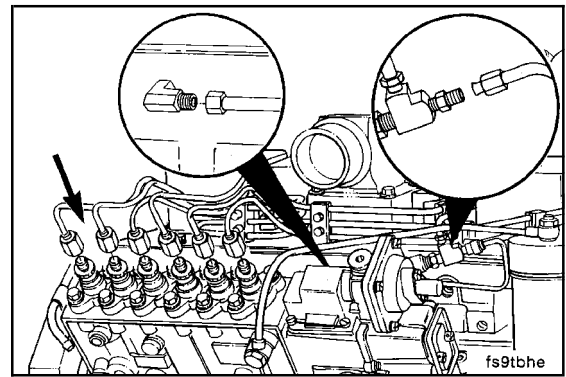

**9/16 Inch**

Install the external oil feed line at the inboard side of the fuel injection pump (if applicable) and the main oil rifle.

Install the external oil feed line at the rear of pump or AFC latchout if applicable.

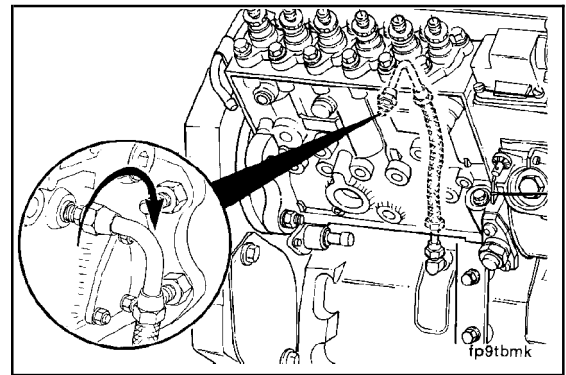

**⚠ WARNING ⚠**

**Keep hands and body parts away from the high-pressure line. Fuel coming from the high-pressure line is under extreme pressure and can cause serious injury by penetrating the skin.**

**19 mm**

Vent the high-pressure fuel lines. Loosen the fitting at the No. 1 injector. Place the fuel control in the run position. Crank the engine so air can bleed from the fuel lines. Then, tighten the fitting.

**Torque Value:** 30 N•m [22 ft-lb]

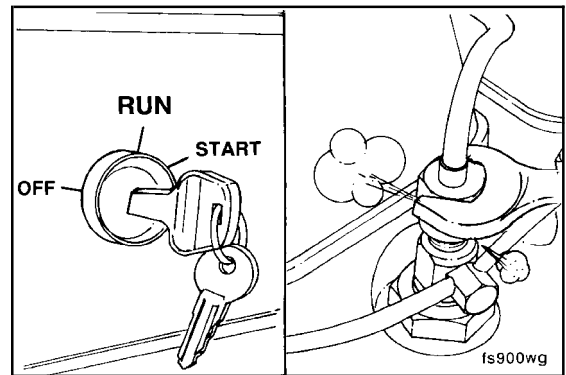

Vent each high-pressure line separately until the engine runs smoothly.

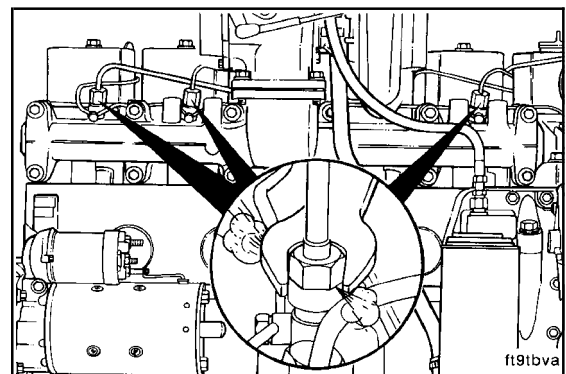

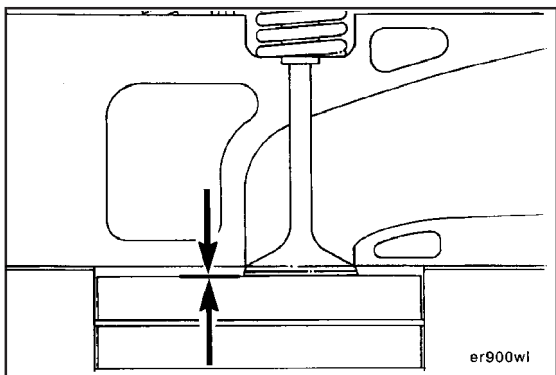

 **Fuel Injection Pump, In-Line, Spill Port Timing (005-013)**

**Time (005-013-051)**

Use the No. 1 intake valve to make sure the engine is at top dead center (TDC) on the compression stroke for cylinder No. 1.

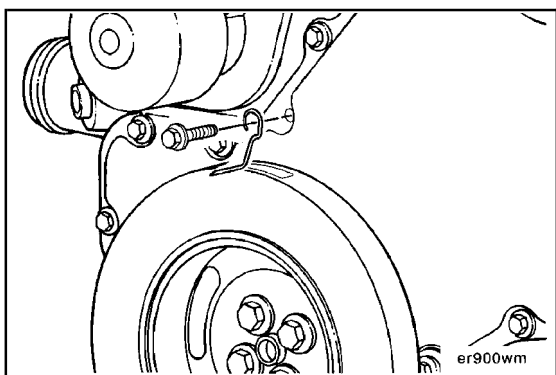

Fabricate a timing mark pointer for the front of the engine. This can be done by forming a piece of wire that can be tightened under one of the gear cover cap screws. Sharpen the wire at the vibration damper end so that it comes to a point for better accuracy.

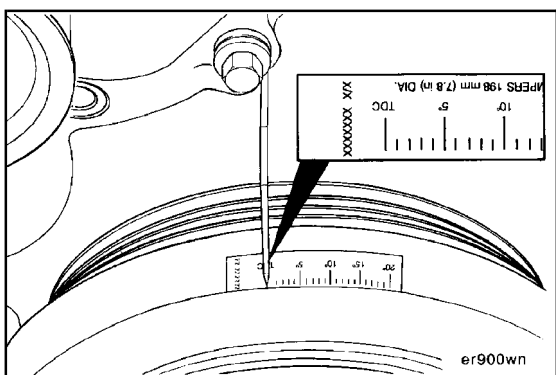

Attach a degree wheel or degree tape to the front of the vibration damper.

Line up the TDC mark with the pointer.

The degree wheel/tape should measure to an accuracy of at least 1 degree.

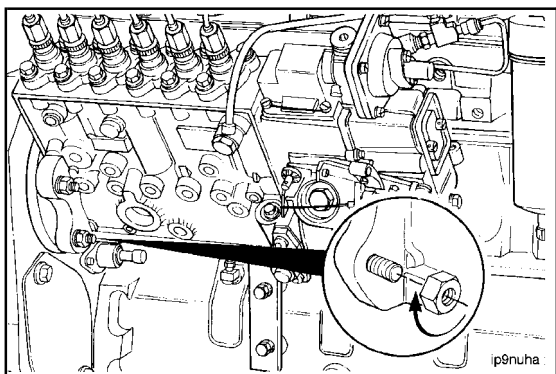

Install the fuel injection pump according to the procedures for a new fuel injection pump installation. If the fuel injection pump is already installed, continue the procedures.

Remove the No. 1 high-pressure fuel line from the fuel injection pump.

**NOTE:** Lines 2 through 6 **must not** be removed or loosened.

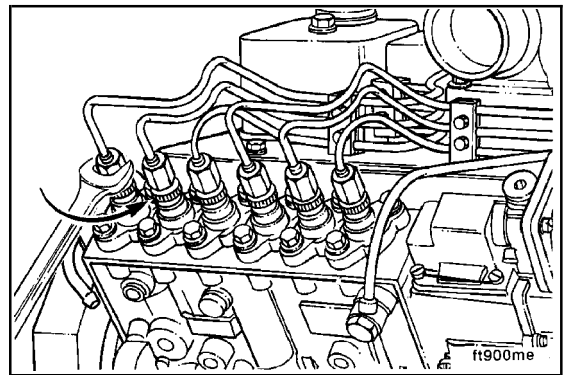

**⚠ CAUTION ⚠**

**When attaching the fabricated tube, do not bend the No. 1 high-pressure fuel line. This could cause the inside of the fuel line to flake and cause injector failure.**

A short length of high-pressure line that is compatible with the fuel lines used on the engine should be bent in a "U" shape and installed onto the delivery valve holder of the fuel injection pump. The line is used to observe when the fuel is or **not** flowing through the delivery valve holder assembly. Place a container under the tube to catch the fuel or drain the fuel back into the spill port pump.

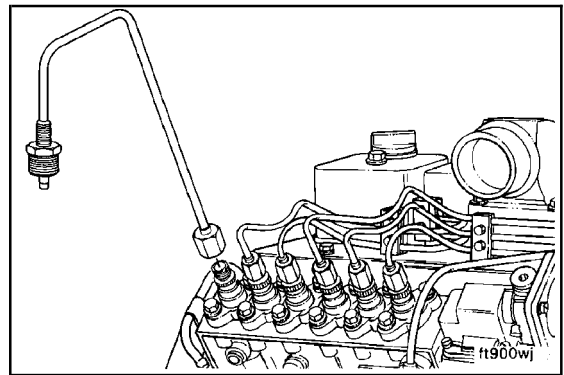

Remove the overflow valve from the fuel injection pump. Install a 14-mm [0.55-in] threaded plug and sealing washer into the fuel return port of the fuel injection pump.

**NOTE:** The fuel return port is located on the inboard front side of the fuel injection pump for automotive in-line application and on the outboard front side for most of the industrial applications.

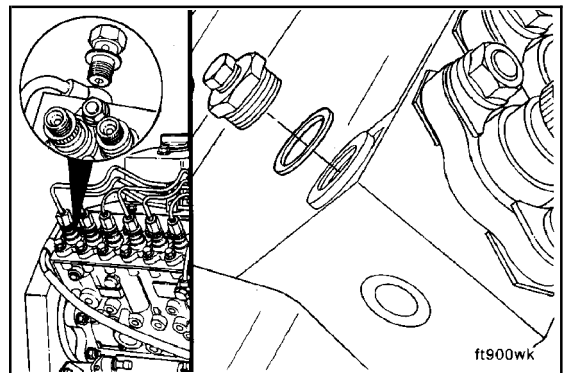

Remove the supply line from the fuel filter head to the fuel injection pump.

Attach the high-pressure outlet hose from the spill port to the fuel injection pump supply port.

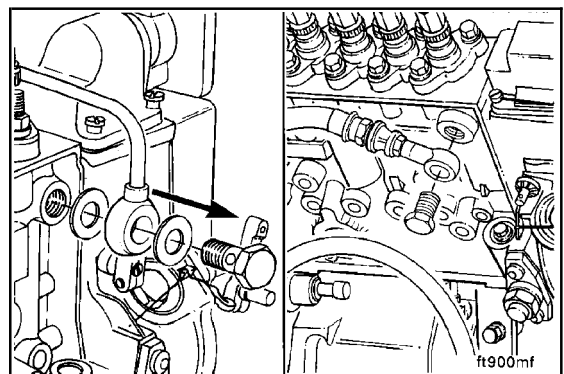

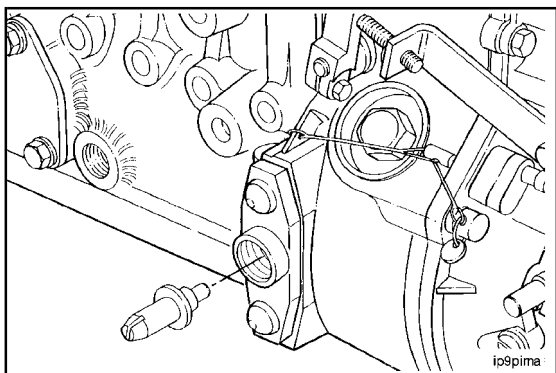

Before continuing, make sure the fuel injection pump lock-timing pin is disengaged.

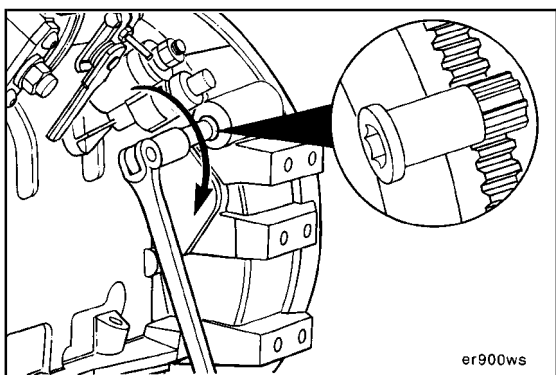

Rotate the crankshaft **counterclockwise**, as viewed from the front of the engine, to approximately 40 degrees before TDC.

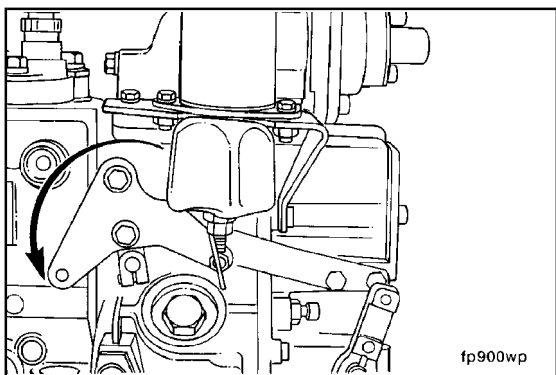

Both the RQV and RQV-K governor require the shutdown lever to be in the full-run position.

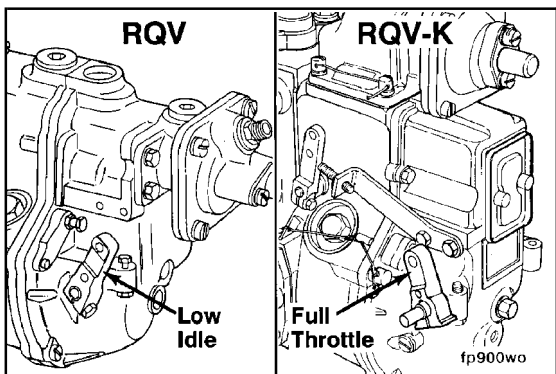

**⚠ CAUTION ⚠**

The governor lever must be positioned before pressurizing the fuel injection pump.

**Governor Lever Positioning**

The RQV governor throttle lever **must** be in the low-idle lever position.

The RQV-K governor throttle lever **must** be in the high-idle throttle position on automotive application.

The RQV-K industrial application **must** be in the low-idle position.

The RSV governor throttle lever **must** be in the low-idle position and the shutdown lever needs to be wired or locked in a suitable fashion to hold the shutdown lever in the 1/2-travel position.

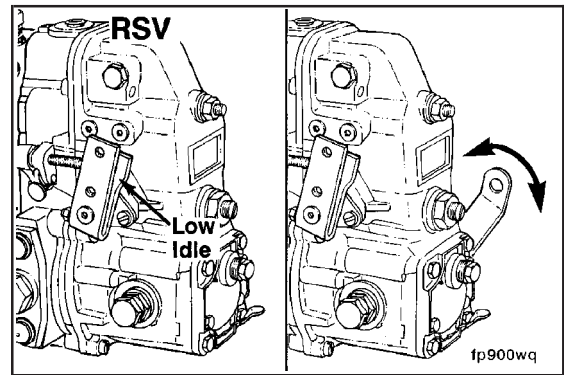

Turn on the spill timing cart pump.

Check the fuel pressure.

The pressure **must** be between 300 psi and 370 psi.

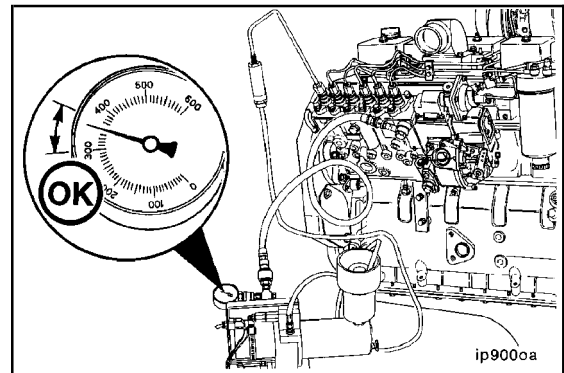

The fuel should be flowing out of the tube attached to the No. 1 cylinder of the fuel injection pump. If the fuel is **not** flowing, recheck the procedures carefully.

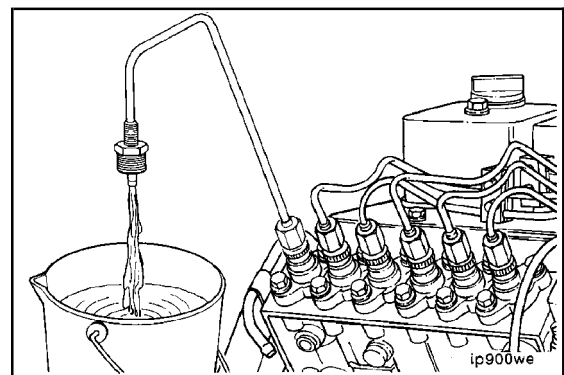

Slowly rotate the crankshaft in the **clockwise** direction, as viewed from the front of the engine, until the fuel flow from the No. 1 cylinder begins to reduce.

The No. 1 plunger element is now approaching "port closure." Continue to rotate the crankshaft slowly until the flow is reduced to a fast drip (more than one drip per second). At the point where the steady stream of flow changes from a solid flow to a fast drip, stop. This is the static timing position of the fuel injection pump.

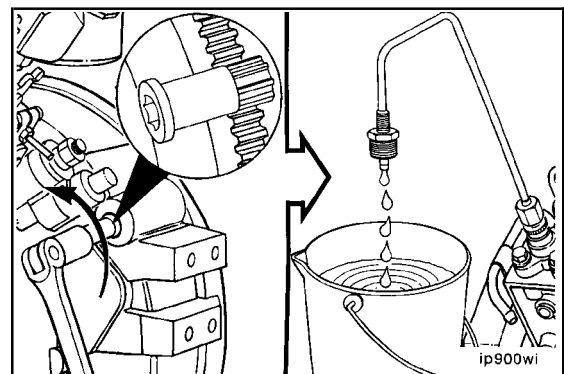

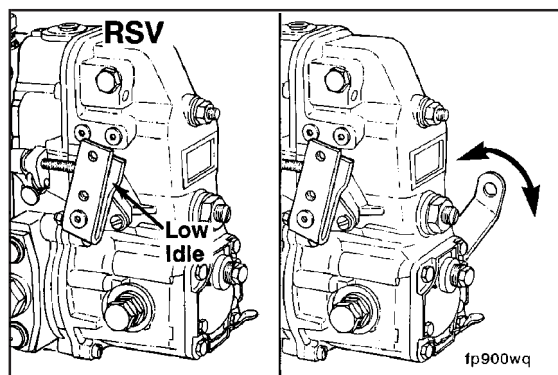

If the flow does **not** slow down to a drip, check the governor position. Also, make sure that the engine is before TDC on the compression stroke.

Turn off the spill port pump.

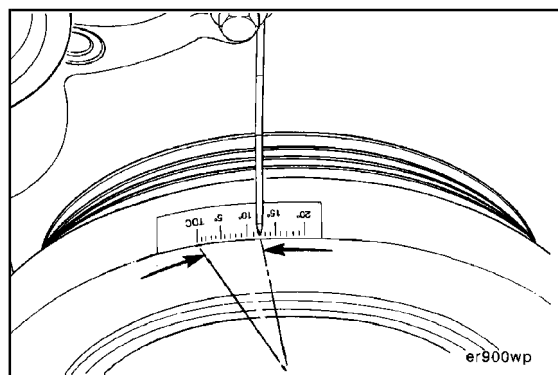

Check the degree wheel on the vibration damper to see what engine degree the timing pointer is indicating. This is spill port static timing. Compare this number to the timing specification for your particular application.

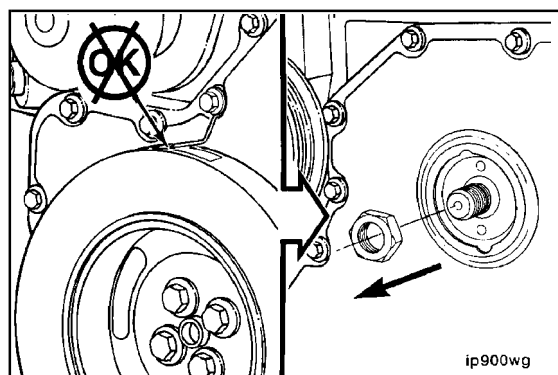

If the fuel injection pump static timing, as measured by the above method, does **not** agree with the specifications you have been given, remove the large nut that fastens the fuel injection pump camshaft to the fuel pump drive gear. If the crankshaft has rotated, turn on the spill port pump, and rotate the crankshaft to find port closure.

Turn off the spill port pump.

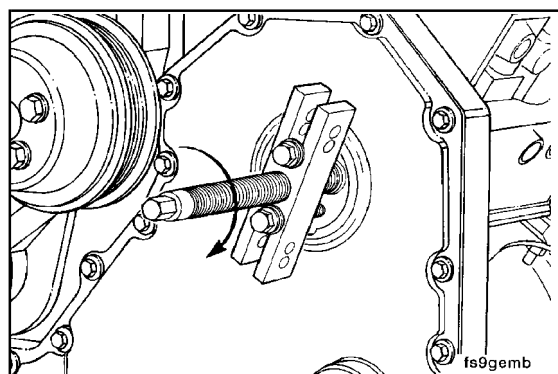

**Fuel Pump Gear Puller, Part No. 3824469**

Use a gear puller tool to pull the fuel injection pump drive gear from the fuel injection pump camshaft taper.



Slowly rotate the crankshaft **counterclockwise** about 40 degrees past the desired static timing specification. Slowly rotate the crankshaft in the **clockwise** direction until the timing pointer is indicating the desired static timing.

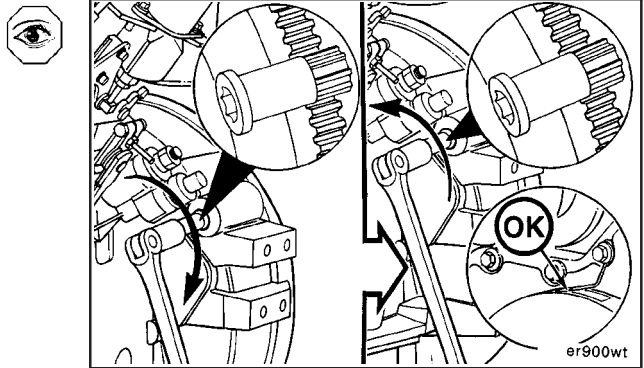

**QD Contact Cleaner, Part No. 3824510**

Clean the gear taper and pump taper with a nonpetroleum-based cleaner (electrical contact cleaner). Allow surface to dry before installing nut.

Tighten the fuel injection pump drive nut.

Make sure the static timing has **not** changed after the fuel injection drive nut is tightened to the required specification.

**Torque Value:**

"A" Pump	85 N•m	[63 ft-lb]
P3000/P7100	195 N•m	[144 ft-lb]

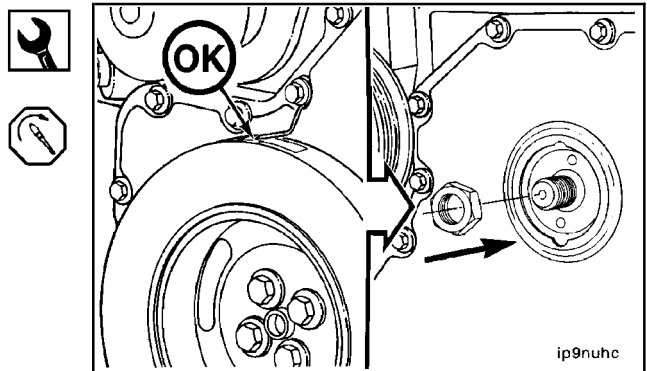

Repeat this procedure as needed until the timing is found to be in agreement with the specification.

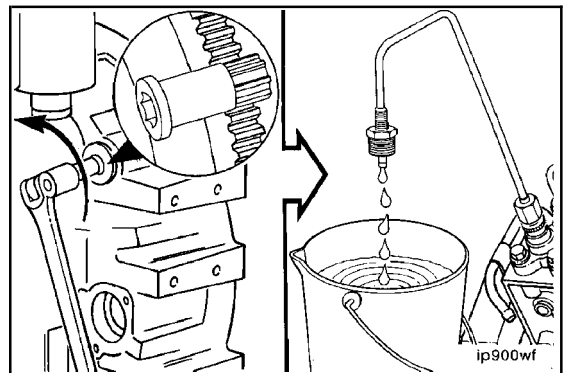

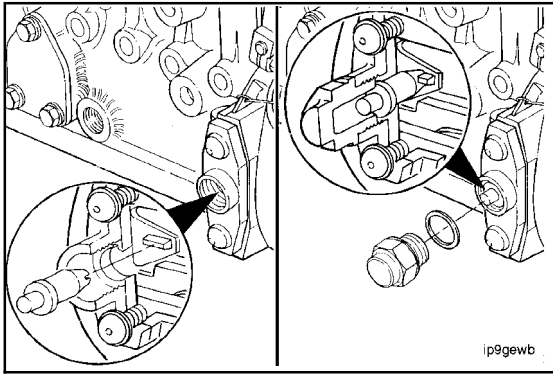

**▲ WARNING ▲**

Wear appropriate eye and face protection when using compressed air. Flying debris and dirt can cause bodily injury.



QD Contact Cleaner, Part No. 3824510



**Torque Value:**

Nippondenso	123 N•m	[91 ft-lb]
Bosch® "A" Pump	85 N•m	[63 ft-lb]
Bosch® In-Line (P3000/P7100) Pump	195 N•m	[144 ft-lb]

**NOTE:** Before installing the fuel pump drive gear, clean the injection pump shaft and gear tapers with a residue free cleaner (Cummins Part No. 3824510, or equivalent) by spraying into the gap between the shaft and the gear. Dry the taper surfaces with compressed air. Failure to clean and dry the shaft and gear tapers thoroughly can result in a timing shift to the retarded side after the engine is started and run under load. This will result in low power, smoke, and rough running.

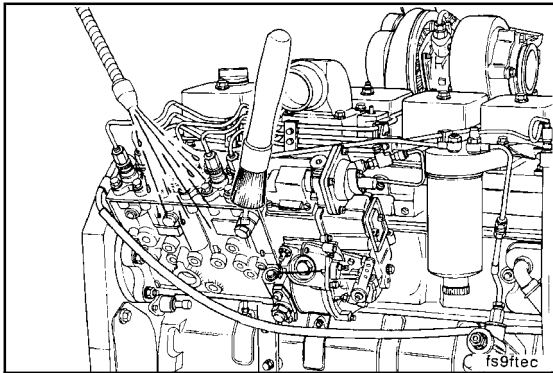

**Plunger Lift Timing (005-013-079)**

**▲ WARNING ▲**

Wear appropriate eye and face protection when using compressed air. Flying debris and dirt can cause bodily injury.



**▲ CAUTION ▲**

Do not allow any dirt, debris, or paint chips to enter the fuel system while it is open. If foreign material of any type is allowed into the pump, lines, or injectors during this process, it could result in an injection pump or fuel injector malfunction.

**NOTE:** This timing procedure can **only** be used on Bosch® P7100 fuel injection pumps.

**Plunger Lift Timing Kit, Part No. 3824563**

The kit contains the following items:

- Dial indicator, Part No. 3824564
- Adapter, Part No. 3824565
- Special socket, Part No. 3824566
- Delivery valve seals, Part No. 3824567.

**Step: 1**

Thoroughly clean the engine and fuel system before attempting to remove any components. Pay special attention to the top of the fuel injection pump. Use compressed air to remove any water remaining on the fuel pump after the cleaning process.



Step: 2

Locate top dead center (TDC) of the compression stroke on cylinder No. 1. The following procedure uses the engine timing pin, but other alternate methods, such as the dropped valve method, can be used.

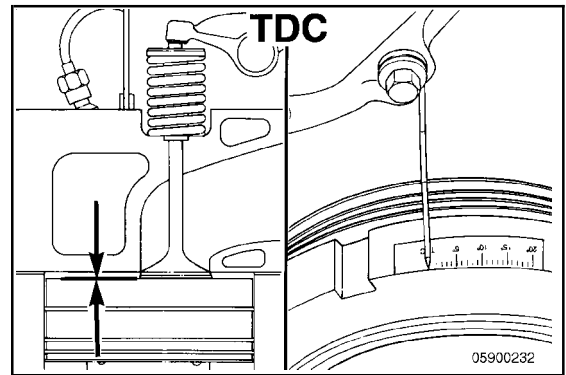

Step: 3

**CAUTION**

**Do not bend the fuel lines. Bending the lines will cause line or injector failure.**

If the injection lines have **not** already been removed, remove the No. 1 injection line.

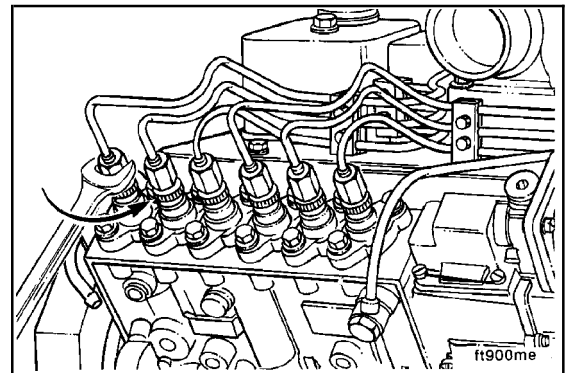

Step: 4

**WARNING**

**Wear appropriate eye and face protection when using compressed air. Flying debris and dirt can cause bodily injury.**

**CAUTION**

**Do not loosen the two barrel flange nuts located below the delivery valve holder. Loosening of these nuts will void the fuel injection pump warranty.**

**NOTE:** There is an external o-ring on the holder to help prevent debris from getting into the pump; this can create a slight resistance as the holder is loosened.

With the engine at TDC, loosen, but do **not** remove the front (No. 1) delivery valve holder using the special socket provided in the timing kit. Use compressed air to remove any paint chips from around the delivery valve holder. Remove the special socket prior to removing the delivery valve holder from the fuel injection pump.

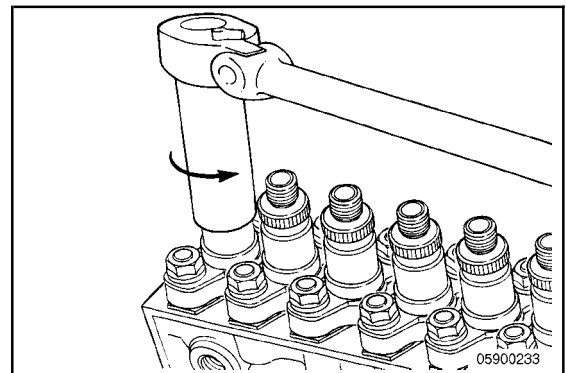

Step: 5

**△ CAUTION △**

Use extreme care when removing the delivery valve holder and delivery valve components. Keep all parts together in the order in which they are removed from the fuel injection pump.

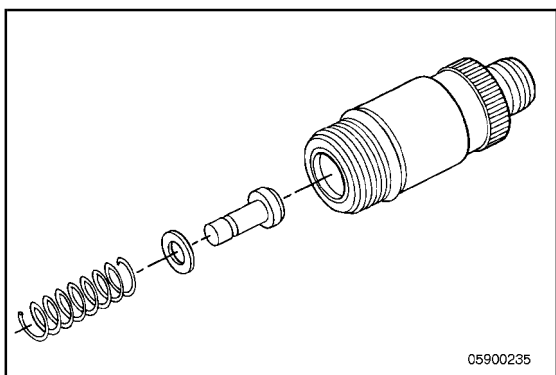
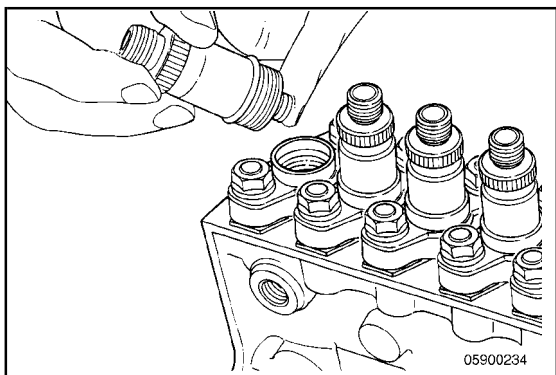

Remove the delivery valve holder by carefully tipping the holder outboard with one hand while using the other hand to hold the spring, fill piece, and any shims from slipping out of the holder. Place these as an assembly on a clean surface out of the way.

Step: 6



Using a magnet, remove the two-piece delivery valve assembly from the pump. Place these pieces on a clean surface with the delivery valve holder.

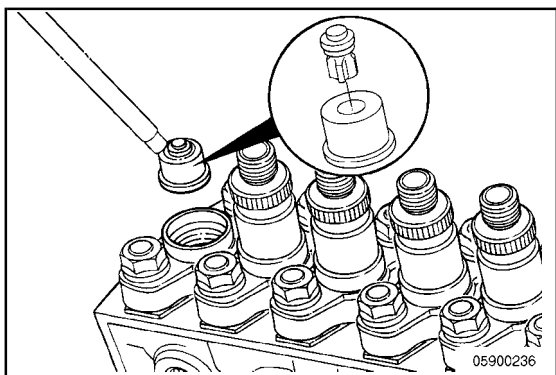

Step: 7



**△ CAUTION △**

Do not scratch the top of the plunger/barrel assembly during gasket removal.

**NOTE:** The delivery valve gasket can be either bronze or steel, or on new injection pumps, there is often no gasket.

If the gasket is bronze, use a pick to remove it from the top of the pumping element; if the gasket is steel, use a pick or a magnet. Discard the used delivery valve gasket.

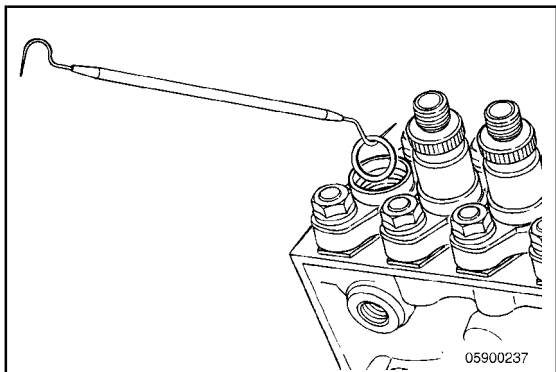

Step: 8

Install the dial indicator from the timing kit in place of the No. 1 delivery valve holder and tighten finger-tight.

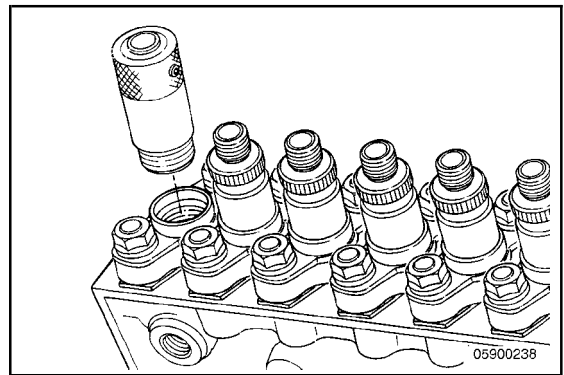

Step: 9

Loosen the set screw on the dial indicator adapter, and install the dial indicator into the adapter. Position the dial indicator to read between 7.0 and 9.0 mm, and lightly tighten the set screw.

Overtightening the set screw will bind the dial indicator.

**NOTE:** The dial indicator is capable of measuring from 0 to 20.00 mm lift. The small inner dial is marked in increments of 1.00 mm; the large outer dial is marked in increments of 0.01 mm. One revolution of the outer dial is equal to 1.00 mm. The inner dial **only** indicates 0 to 10.00 mm, but will rotate twice as the indicator goes through the full range.

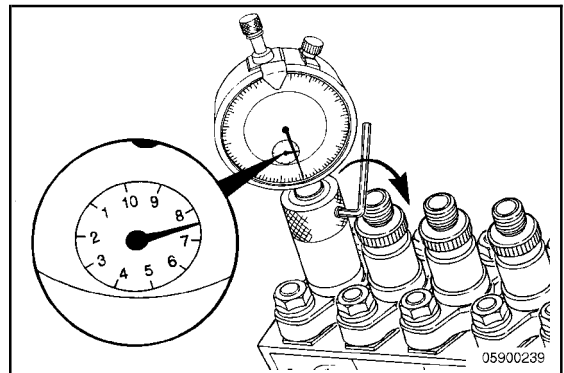

Step: 10

**CAUTION**

**Be sure to disengage the timing pin before rotating the crankshaft to avoid damage to the timing pin.**

Use a barring tool to rotate the crankshaft in the direction opposite normal direction of crankshaft rotation (**counterclockwise** from front of the engine) 1/4 turn or until the dial indicator reading stops dropping. This is the inner base circle of the fuel injection pump camshaft. Zero "0" the indicator and note the reading on the small inner dial.

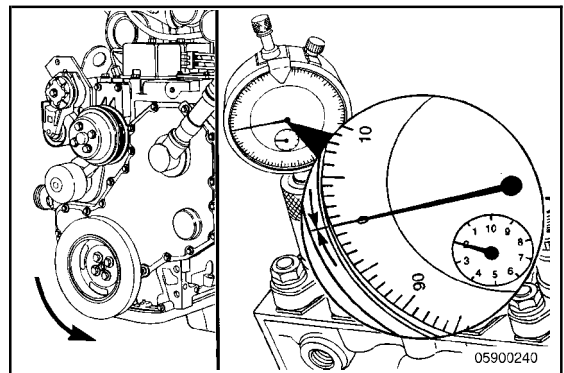

Step: 11

Rotate the crankshaft slowly to TDC in the direction of normal crankshaft rotation (**clockwise** from front of the engine).

The total lift **must** be within the specified lift for that CPL. The attached table lists the lift setting in millimeters (mm) that corresponds to the engine timing specification in degrees.

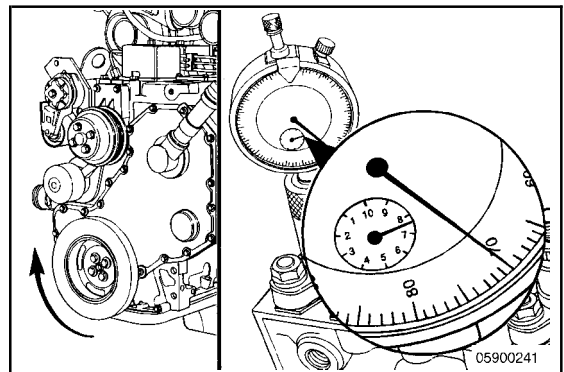

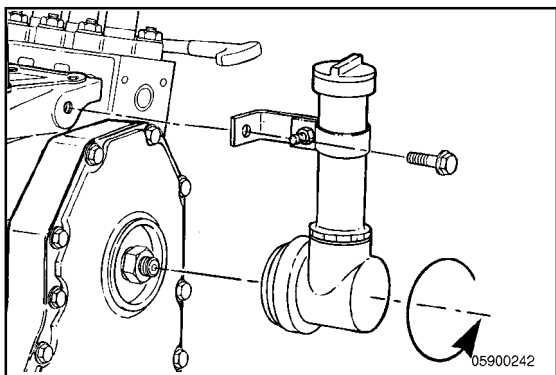

Step: 12

If a change in injection timing is required, remove the oil filler tube and adapter elbow or fuel injection pump gear access cap from the front of the gear housing.

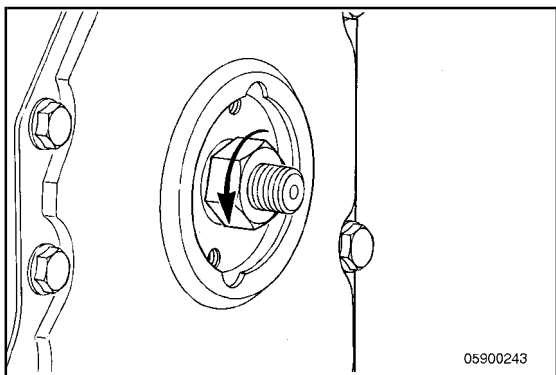

Step: 13

**⚠ CAUTION ⚠**

**Be sure to disengage the timing pin before rotating the crankshaft to avoid damage to the timing pin.**

Loosen the injection pump shaft nut approximately 1/4 turn. The barring tool can be used to keep the crankshaft from rotating.

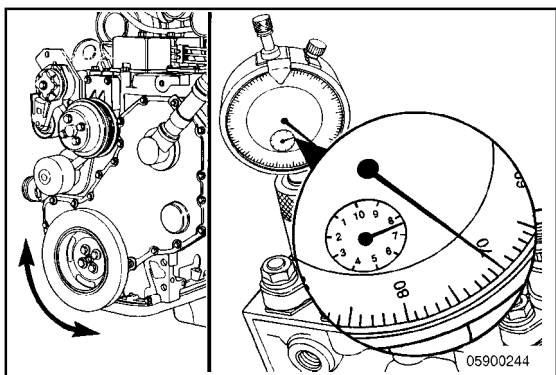

Step: 14

If the actual lift setting is **not** within specification, rotate the crankshaft to obtain the desired dial indicator setting (plunger lift).

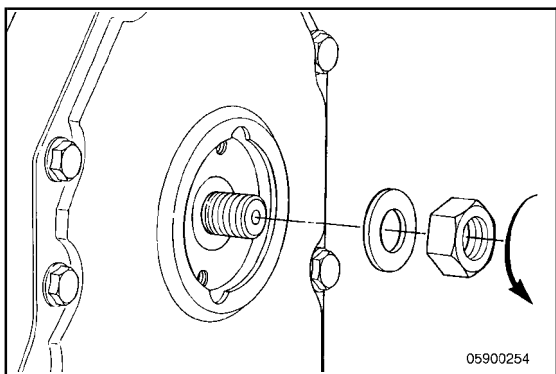

**⚠ CAUTION ⚠**

**Do not allow the drive nut or washer to drop inside the engine gear cover. Disassembly of the engine will be required for retrieval.**

Remove the fuel injection pump driveshaft nut and lock washer.

Service Tip: Use a pointed object such as a metal awl and a magnet, to assist in the removal of the lock washer.

Step: 15

**Gear Puller, Part No. 3824469**

With the fuel injection pump positioned at the correct plunger lift setting, use the gear puller, Part No. 3824469, or equivalent, to pull the injection pump gear off the taper of the injection pump input shaft. Remove the gear puller.

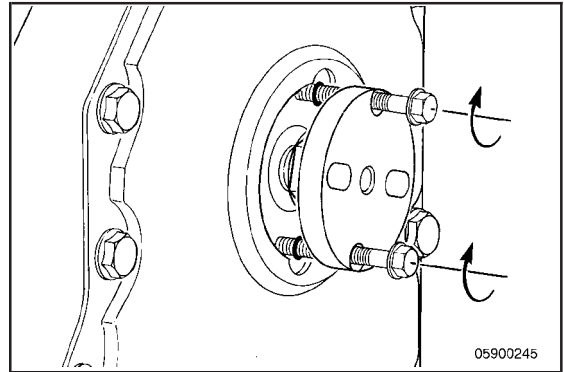

05900245

Step: 16

Rotate the crankshaft 20 degrees to 30 degrees opposite the direction of normal crankshaft rotation; then rotate the crankshaft back in the direction of normal crankshaft rotation to TDC. This step removes the backlash from the lower gear train.

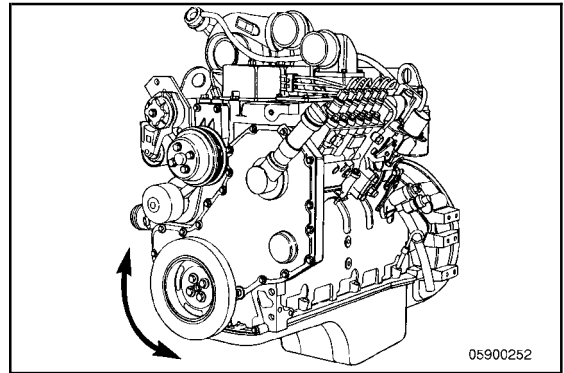

05900252

Step: 17

**QD Contact Cleaner, Part No. 3824510**

Clean the fuel injection pump shaft and gear tapers with a residue-free cleaner (Cummins Part No. 3824510, or equivalent) by spraying into the gap between the shaft and gear. Dry the taper surfaces with compressed air. Failure to clean and dry the shaft and gear tapers thoroughly can result in a timing shift to the retarded side after the engine is started and run under load. This will result in low power, smoke, and rough running.

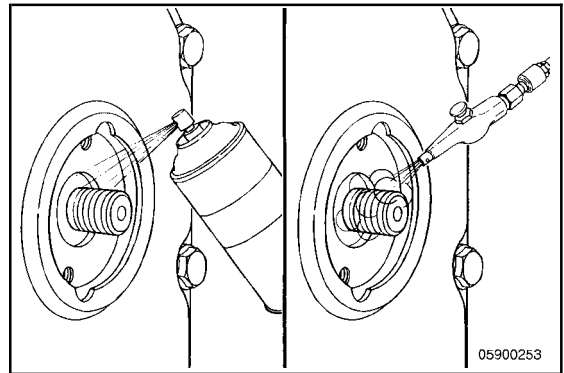

05900253

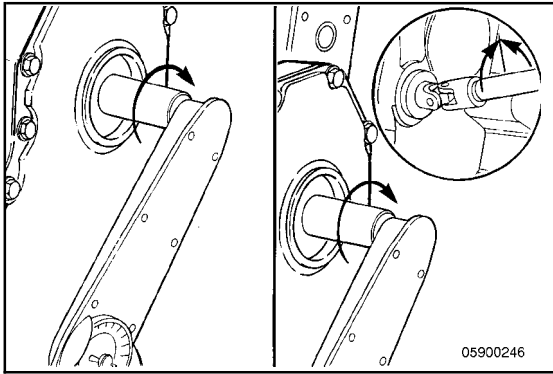

Step: 18

**▲ CAUTION ▲**

**Be sure the timing pin is disengaged before the final tightening step to avoid damage to the timing pin.**



Install the input shaft lock washer and nut. Use a 2-step tightening process to tighten the fuel injection pump gear nut.

**Torque Value:** 15 N•m [133 in-lb]

This will seat the shaft taper.

Hold the crankshaft from rotating (using the barring tool or other means) on the final step of the tightening sequence.

**Torque Value:** 165 N•m [122 ft-lb]

Step: 19

Repeat steps 10 and 11 to verify that the final timing setting is correct.

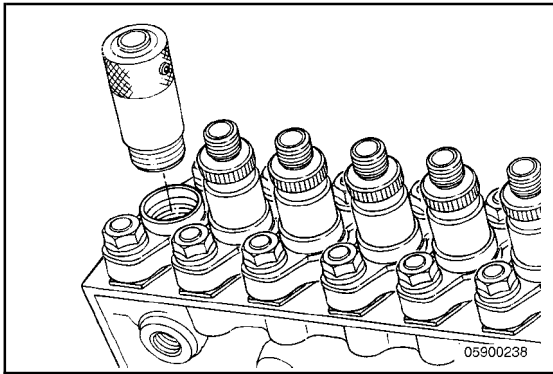

Step: 20

**▲ CAUTION ▲**

**The following steps for installing and tightening the delivery valve and holder must be followed exactly. Improper installation will result in delivery valve damage or leaks.**

Remove the dial indicator and adapter from the fuel injection pump.

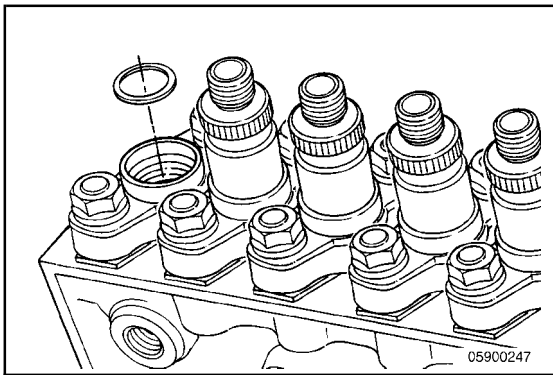

Step: 21

Inspect the fuel injection pump bore for debris. The bore **must** be free of debris.

If a gasket was removed from under the delivery valve, install a new delivery valve gasket (Cummins Part No. 3824567) into the fuel injection pump. Do **not** use a gasket if this is a pump with gasketless delivery valves. See attached list of pumps that have or do **not** have delivery valve gaskets.

Step: 22

**QD Contact Cleaner, Part No. 3824510**

Clean the delivery valve parts with residue-free cleaner (Cummins Part No. 3824510, or equivalent) prior to reassembly.

Install the delivery valve assembly.

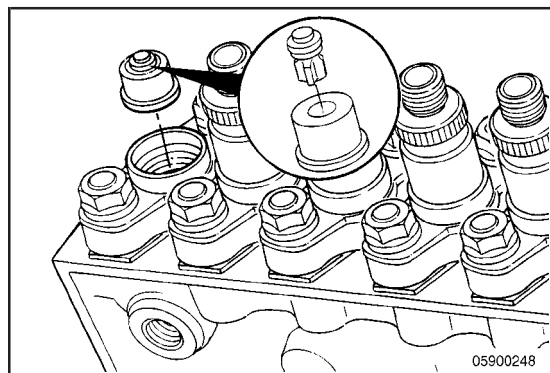

Step: 23

Lubricate the threads and clamping surface of the delivery valve holder with a few drops of SAE 90 hypoid gear oil. Do **not** lubricate the delivery valve gasket or its seating area.

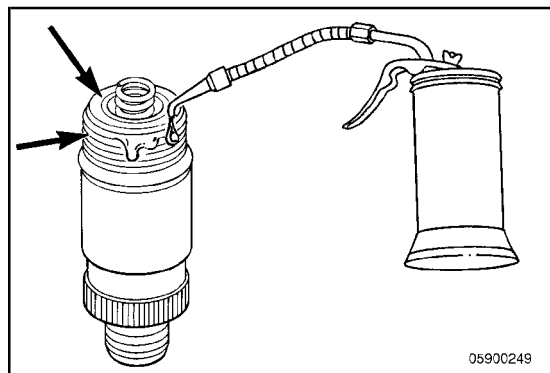

Step: 24

Install the delivery valve holder assembly, taking care **not** to displace the delivery valve spring, fill piece, or any shims.

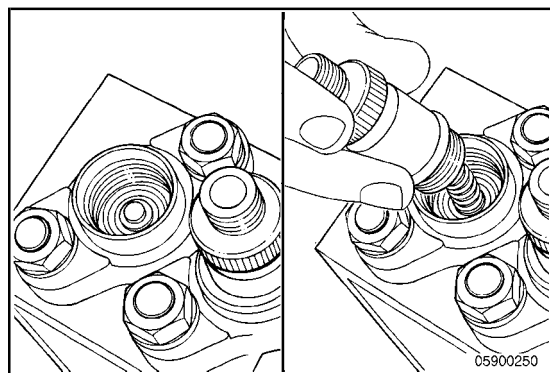

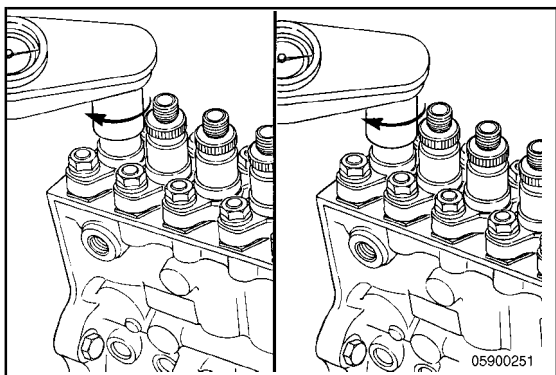

Step: 25



**▲ WARNING ▲**

Keep hands and body parts away from the high-pressure fuel lines. Fuel coming from the high-pressure fuel lines is under extreme pressure and can cause serious injury by penetrating the skin.

Use step 1 to initially tighten the holder; then, in one motion, use step 2 for the final torque value.

<b>Torque Value:</b>	Step 1	40 N•m	[29 ft-lb]
	2	115 N•m	[85 ft-lb]

Install the remaining engine components removed during the TDC location or timing process. Leave the injector side of the high-pressure fuel lines loose to facilitate bleeding the air out of the system.

Crank the engine until fuel is observed at the injectors. Tighten the high-pressure lines at the injector. Start the engine, and vent one line at a time until the engine runs smoothly. Check for leaks.



The following is a list of Bosch® P7100 fuel injection pumps that use delivery valve gaskets. Pumps used in ratings developed after these should use gasketless delivery valves. If the pump was developed in North America and it is **not** on this list, it should be gasketless. If unsure about the type of pump, call the Technical Support Hotline, (812) 377-6517.

---

Part No.	
3913340	3921922
3916626	3921923
3916627	3921925
3916628	3921970
3916629	3922424
3917088	3922425
3917089	3922426
3918321	3922427
3919090	3922446
3921769	3922449
3921770	3922471
3921771	3924903
3921772	3925085
3921773	3925086
3921774	3926603
3921775	3927923
3921776	3927924
3921777	3928169
3921918	3928412
3921920	3928606

The following table supplies the lift specifications for the Bosch® P7100 fuel injection pumps **only**. The allowable tolerance range for timing is ± 0.1 mm.

Control Parts List						
Static Injection Timing (from engine dataplate, degrees BTDC)	987, 1261, 1262, 1263, 1406, 1422, 1582, 1618, 1850, 2118, 2196	1549, 1550, 1551, 1552, 1553, 1815, 1816, 1839, 1914, 1915, 1916, 1959	1863, 1968, 2022, 2174, 2265, 2268, 2308	2023, 2175	1563, 1566, 1569, 1658, 1812, 1905, 1917, 1918, 1920, 1922, 1923, 1949, 1950, 1972, 2034, 2101, 2103, 2104, 2106, 2107, 2108, 2150	1564, 1919, 2011, 2102, 2105, 2158, 2169, 2191
9.5	6.05	5.15	N/A	N/A	5.65	5.6
10	6.15	5.25	N/A	N/A	5.75	5.7
10.5	6.25	5.35	N/A	N/A	5.85	5.8
11	6.35	5.45	4.0	N/A	5.95	5.9
11.5	6.4	5.55	4.05	4.7	6.05	6
12	6.5	5.65	4.15	4.8	6.15	6.05
12.5	6.6	5.7	4.2	4.9	6.25	6.15
13	6.7	5.8	4.3	5	6.35	6.25
13.5	6.8	5.9	4.4	5.1	6.45	6.35
14	N/A	6.0	4.5	5.2	N/A	N/A
14.5	N/A	6.1	4.6	5.3	N/A	N/A
15	N/A	N/A	4.7	5.4	N/A	N/A

The following table supplies the lift specifications for the Marine Midrange engines. The nominal value for control parts list (CPL) 1975 is 22 degrees and CPL 2172 and 2208 is 24 degrees. The allowable range for timing remains at ± 1 degree of nominal.

Static Injection Lift Value	Control Parts List	
	Marine B Series CPL(s) 1975, 2208	Marine C Series CPL 2172
20.0	7.90	7.29
20.5	8.02	7.40
21.0	8.14	7.52
21.5	8.26	7.63
22.0	8.38	7.75
22.5	8.51	7.87
23.0	8.63	7.98
23.5	8.75	8.10
24.0	8.88	8.22
24.5	9.01	8.34
25.0	9.13	8.47
25.5	9.26	8.59
26.0	9.39	8.71

## Fuel Injection Pump, Rotary (005-014)

### General Information

#### Fuel System Identification

The B Series engine uses many different fuel injection pumps depending on the horsepower rating and application.

The Lucas CAV DPA distributor-type fuel injection pump can be found on the following engine applications:

- Marine
- Industrial.

The Lucas CAV DPS distributor-type fuel injection pump can be found on the following engine application:

- European and U.K. automotive ratings.

The Bosch® VE distributor-type fuel injection pump can be found on the following engine applications:

- Industrial
- 1991 low-horsepower automotive ratings.

The Stanadyne DB4 distributor-type fuel injection pump can be found on the following engine application:

- Gensets.

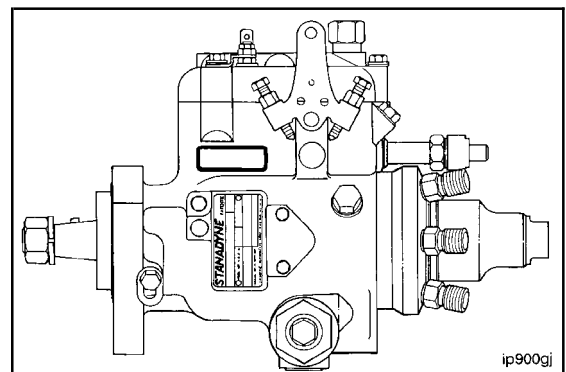
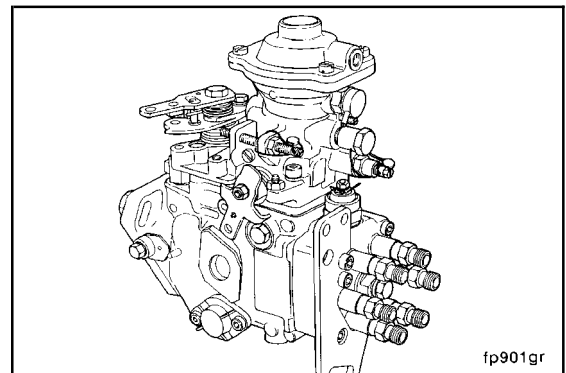
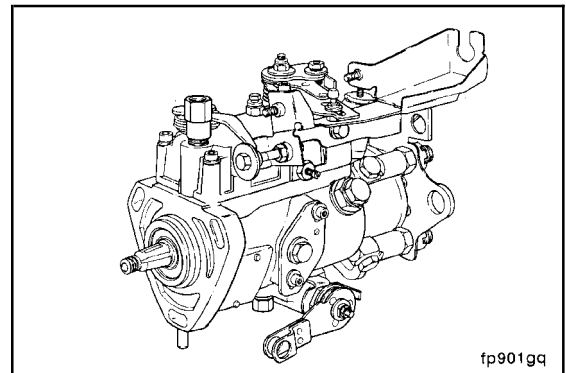
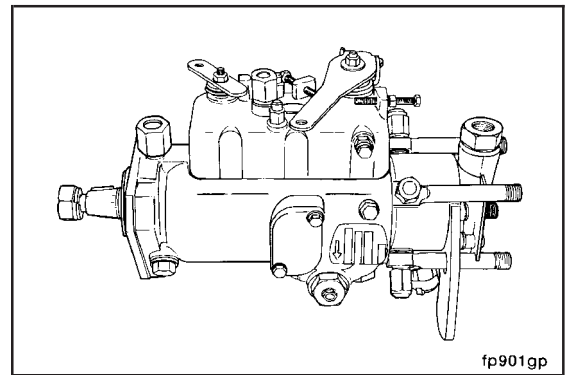

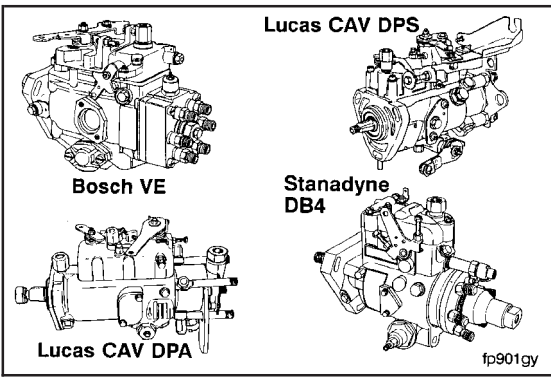

**Fuel Injection Pump (Distributor Type)**

The fuel injection pumps, Bosch® VE, Lucas CAV DPA, Stanadyne DB4, and Lucas CAV DPS, are rotary distributor pumps. These pumps perform the four basic functions of:

1. Producing the high fuel pressure required for injection
2. Metering the exact amount of fuel for each injection cycle
3. Distributing the high-pressure, metered fuel to each cylinder at the precise time
4. Varying the timing relative to engine speed.

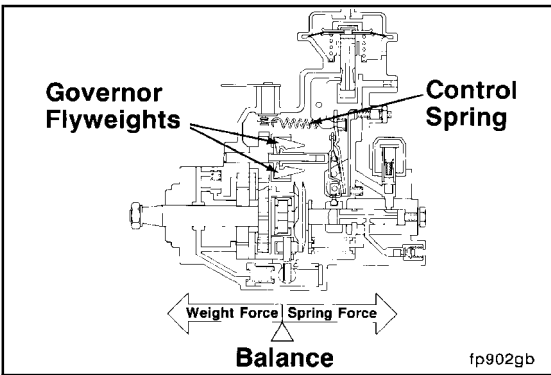

**Distributor-Type Pump Governor**

Balance between the governor flyweights and control lever position controls the metering of the amount of fuel to be injected.

The fuel injection pump governor performance and setting can affect engine power. Special equipment and qualified personnel are required to verify governor performance. If the seals are broken on the external Bosch® VE adjustment screw, the fuel rate can, perhaps, be out of adjustment.

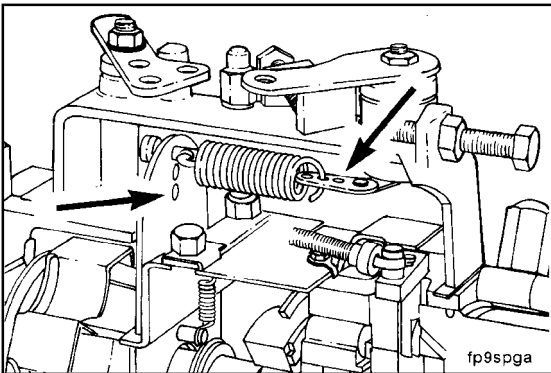

The Lucas CAV DPA/DPS fuel injection pump uses a coded spring connection to change the governor setting. Incorrect connection of the governor spring can affect performance.

Adjustments and rating changes are described in the Master Repair Manual, Injector Pumps and Injectors, Bulletin No. 3666037.

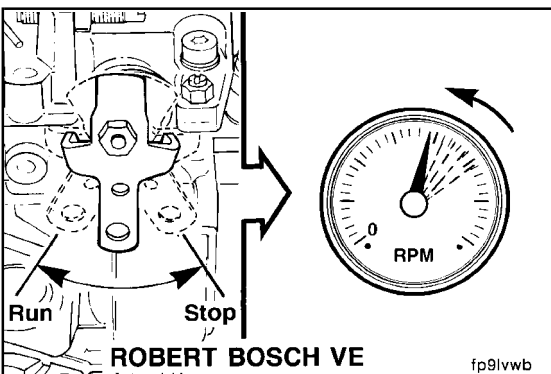

**Manual Shutdown Levers**

Both fuel injection pumps are equipped with mechanical shutdown levers. These levers are spring-loaded in the run position. **Not** all applications will use these manual shutdown controls, and there will be no cable or rod connected to the lever.

**NOTE:** Partial actuation of the mechanical shutdown levers will affect fuel flow and engine power.

**Advance Timing Mechanism**

Regulated pressure produced by a vane supply pump in both fuel injection pumps is used to advance the timing as the engine speed increases. A return spring is used to retard the timing as the engine speed is reduced. If a spring should break, the timing will go to the advance position, resulting in torque loss, fuel knock, and possible engine overheating.

Retarded (late) timing will result in torque loss, high fuel consumption, and white to black smoke.

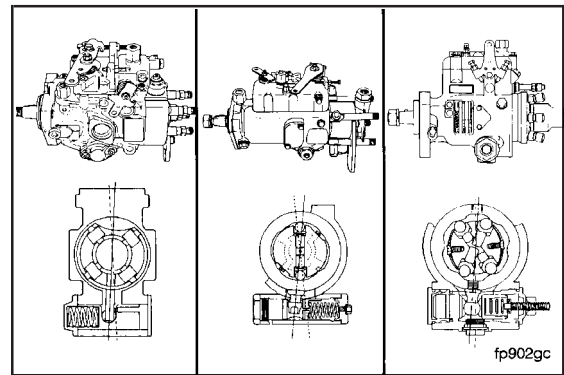

The Lucas CAV DPA/DPS advance timing mechanism uses a check ball in the circuit which, if omitted during assembly, will result in no timing advance. If the fuel injection pump has been replaced or the mechanism has been removed to fix a leak, the problem can be that the check ball is missing.

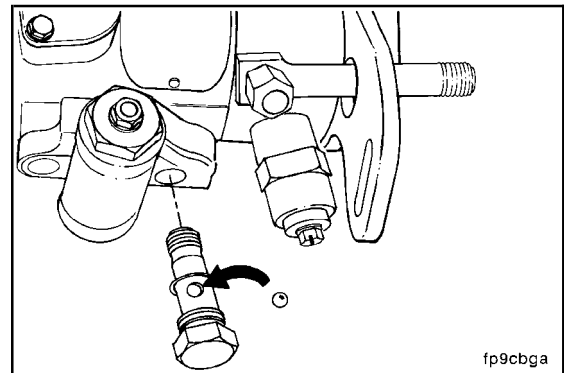

**Electrical Shutoff Valves**

The fuel injection pumps are equipped with electrical shutoff valves. These solenoid-operated valves block the supply of fuel to the high-pressure pumping and distribution components.

The Bosch® VE shutoff valve is located at the top rear of the pump.

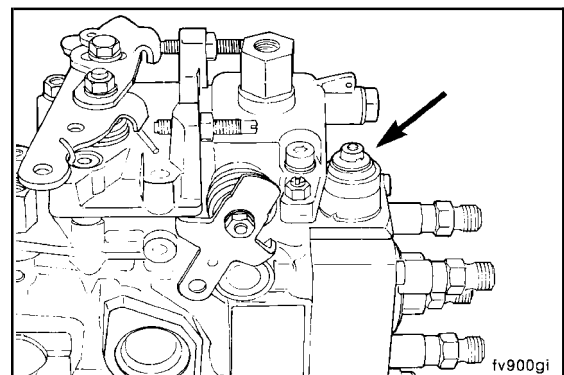

The Lucas CAV DPA/DPS shutoff valve is located at the bottom rear of the pump.

Both 12- and 24-VDC activate-to-run and activate-to-stop solenoids are available.

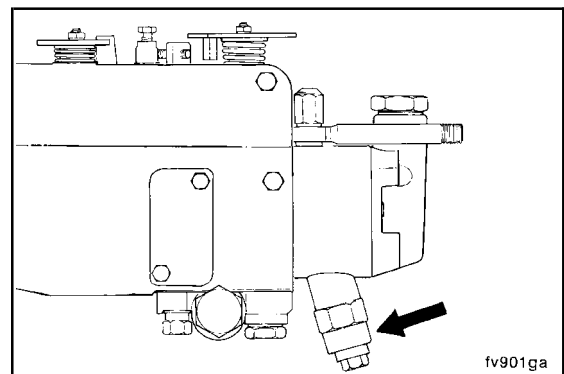

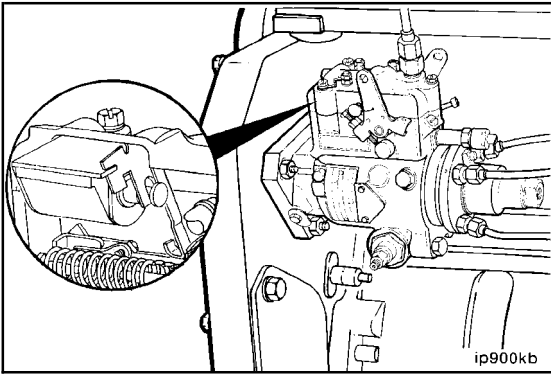

The Stanadyne DB4 shutdown solenoid is located under the governor cover.

Both 12-VDC and 24-VDC energize-to-run and energize-to-stop solenoids are available.

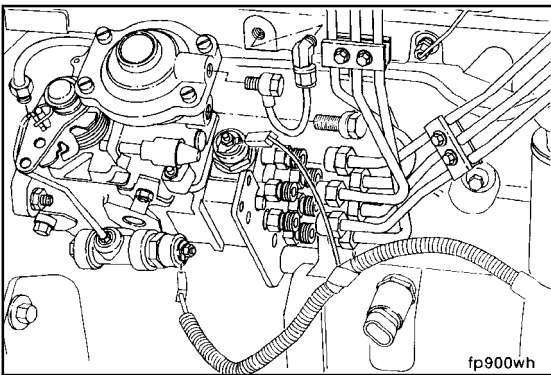

**Preparatory (005-014-000)**

**Rotary Distributor Type Fuel Injection Pumps**

**Bosch® VE, Lucas CAV DPA and Stanadyne DB4**

- Disconnect the fuel drain manifold. Refer to Procedure 006-021.
- Remove the injection pump supply line. Refer to Procedure 006-024.
- Remove the high-pressure lines. Refer to Procedure 006-051.
- Disconnect the electrical wire to the fuel shutoff valve. Refer to Procedure 005-043.
- Remove the fuel air control tube, if used. Refer to Procedure 006-001.

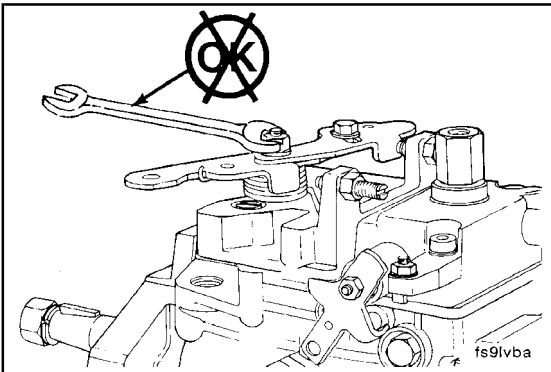

**Remove (005-014-002)**

**⚠ CAUTION ⚠**

Do not remove the control lever. The fuel control lever on the Bosch® VE fuel injection pump is indexed to the shaft during pump calibration. If the lever has been removed and reinstalled incorrectly, engine speed and power will be affected.

Disconnect all control linkage. Refer to OEM service manual.

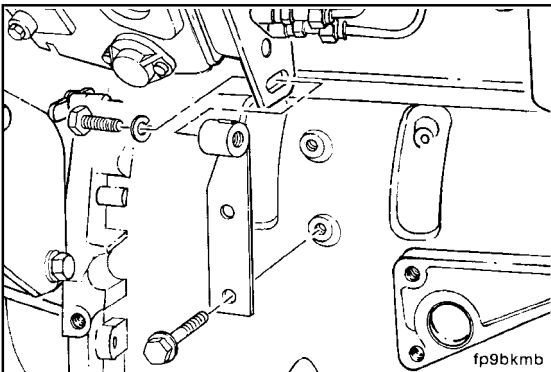

**13 mm**

Remove the pump support bracket.



22 mm

Remove the access cap and gear retaining nut and washer.

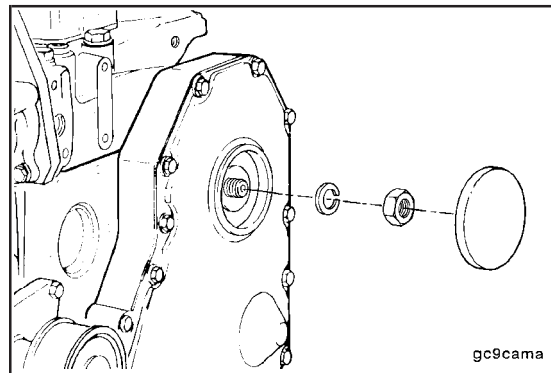

**NOTE:** Be sure to disengage the pin after locating TDC.  
Locate TDC for cylinder No. 1 by barring engine slowly while pushing in on TDC pin.

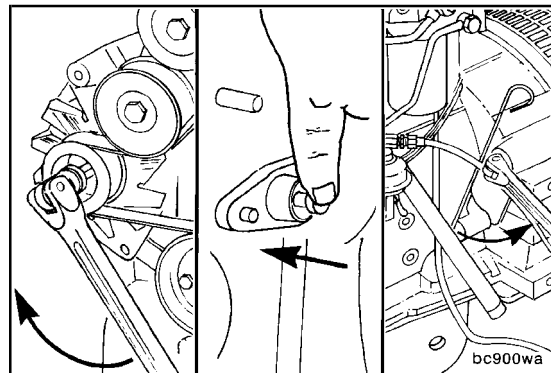

9/16 Inch

**Lucas CAV DPA Pump**

Loosen the CAV fuel injection pump lock screw, and position the special washer; then tighten the lock screw against the pump driveshaft.

**Torque Value:** 7 N•m [62 in-lb]

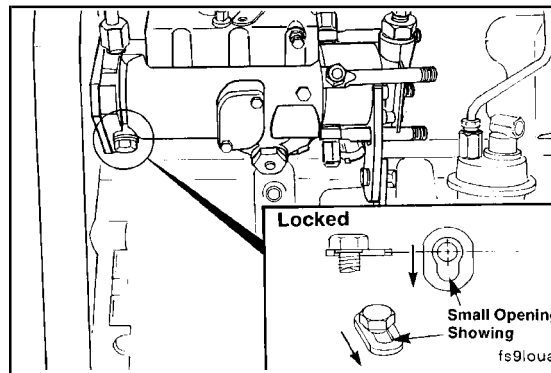

3/8 Inch

**Stanadyne DB4 Pump**

Loosen the Stanadyne DB4 fuel injection pump lock screw, and position the special washer. Tighten the lock screw until contact is made with the fuel injection pump driveshaft.

**Torque Value:** 12 N•m [106 in-lb]

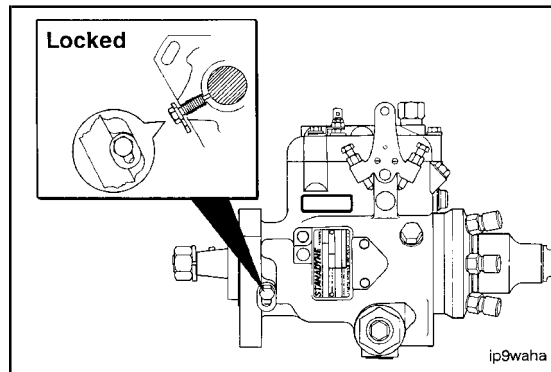

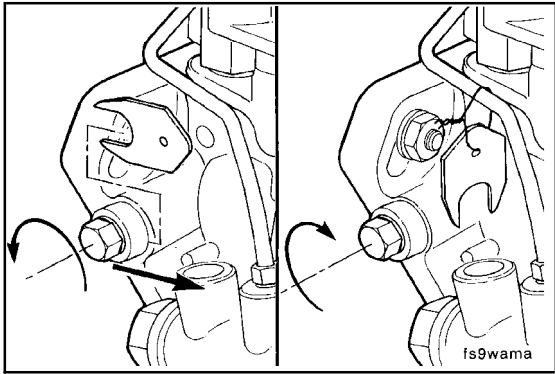

8-mm Allen Wrench or 10-mm Hex

Bosch® VE



The special washer on the Bosch® VE injection pump **must** be removed so the lock screw can be tightened against the driveshaft.



**Torque Value:** 30 N•m [22 ft-lb]

**NOTE:** Wire the washer to the pump.

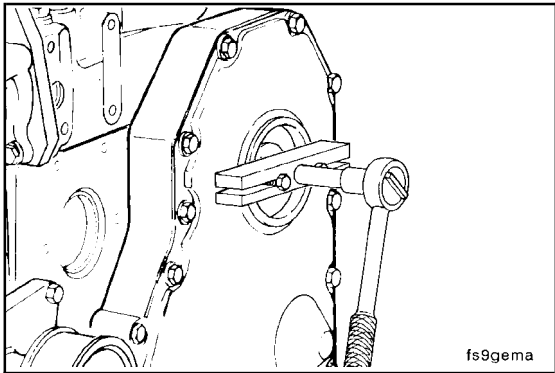

75 mm T-Bar

Pull the fuel injection pump drive gear loose from the pump driveshaft.

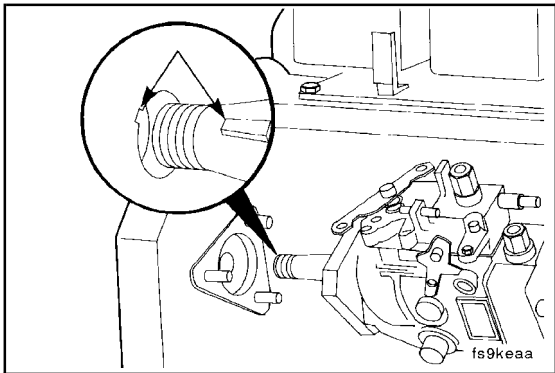

**CAUTION**

Do not drop drive gear key when removing the pump. Failure to do so can result in severe engine damage.



13 mm

Remove the three mounting nuts, and take off the fuel injection pump.

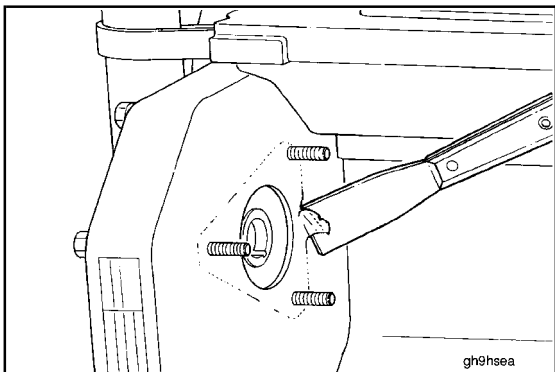

Remove the gasket, and clean the surface.





**Install (005-014-026)**

Verify cylinder No. 1 is at TDC by barring engine slowly while pushing in on TDC pin.

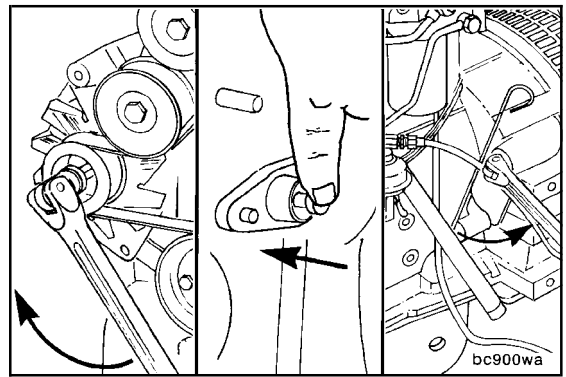

Install a new gasket.

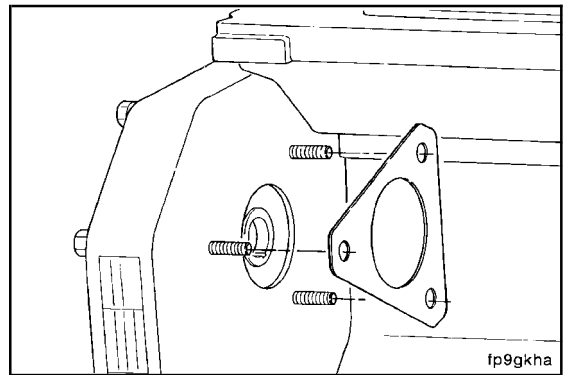

**⚠ CAUTION ⚠**

The driveshaft must be clean and free of all oil before installation. Failure to make certain the driveshaft is free of oil can result in the drive gear slipping on the shaft.

**NOTE:** The shaft of a new or reconditioned pump is locked so the key aligns with the drive gear keyway when cylinder No. 1 is at TDC on the compression stroke.

Install the pump. Make sure the key does **not** fall into the gear housing.

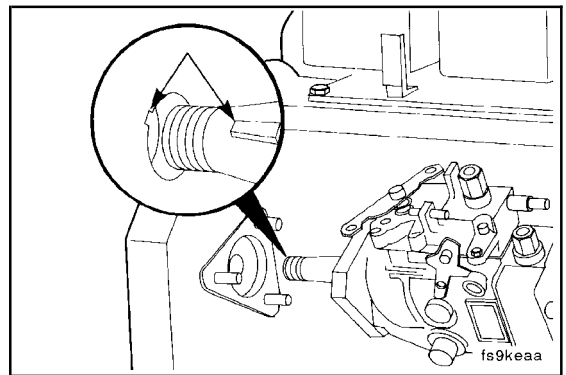

Use your hands to tighten the three mounting nuts. The pump **must** be free to move in the slots.

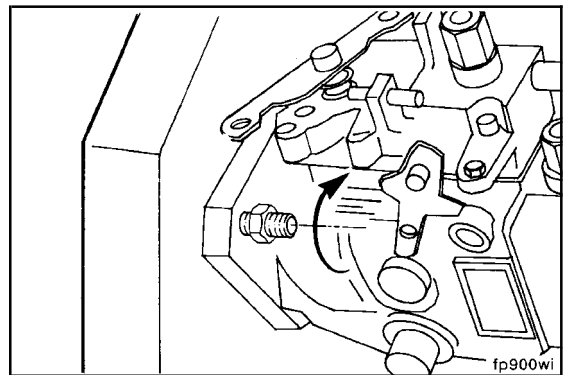

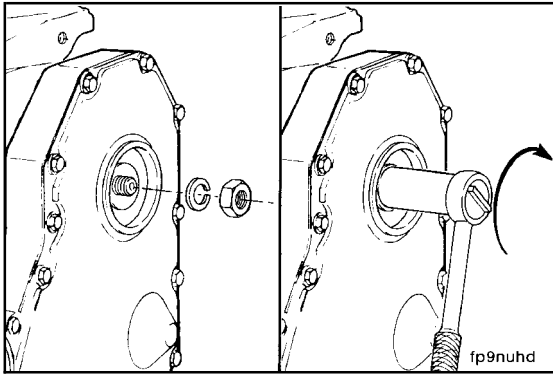

**CAUTION**

Be sure the timing pin is disengaged before the final torque step to avoid damage to the timing pin.



22 mm



Install the pump driveshaft nut and spring washer. The pump will rotate slightly because of gear helix and clearance. This is acceptable provided the pump is free to move on the flange slots and the crankshaft does **not** move.

**Torque Value:** 15 to 20 N•m [133 to 177 in-lb]

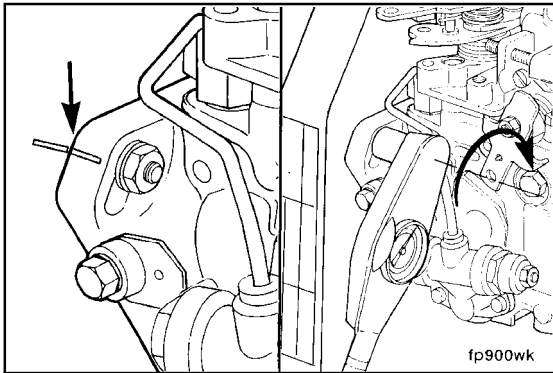

13 mm

If installing the original pump, rotate the pump to align the scribe marks.



**Torque Value:** 24 N•m [18 ft-lb]

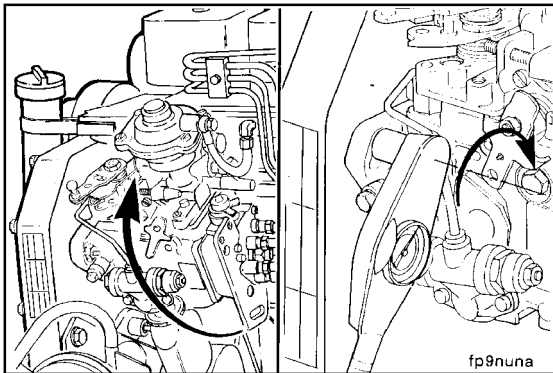

If installing a new or rebuilt pump without scribe marks, take up gear lash by rotating the pump against the direction of drive rotation. Tighten the flange mounting nuts.



**Torque Value:** 24 N•m [18 ft-lb]

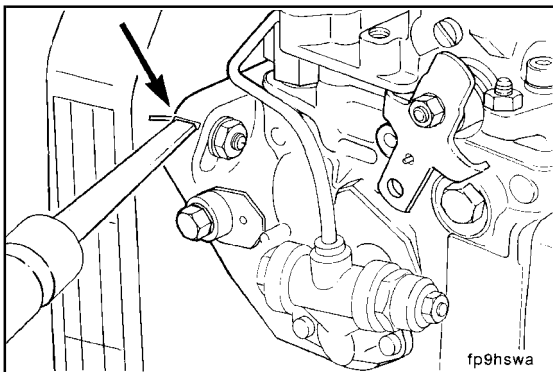

Permanently mark the injection pump flange to match the mark on the gear housing.

**B3.9 and B5.9 Series Engines  
Section 5 - Fuel System - Group 05**

**9/16 Inch**

Loosen the CAV pump lockscrew and position the special washer behind the lockscrew head.

**Torque Value:** 20 N•m [15 ft-lb]

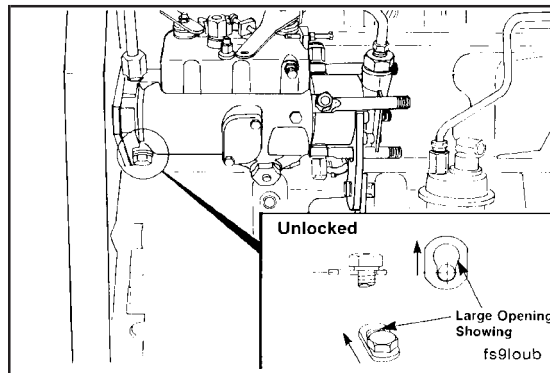

**3/8 Inch**

Loosen the Stanadyne DB4 fuel injection pump lock screw, and position the special washer behind the lock screw head.

Tighten the lock screw.

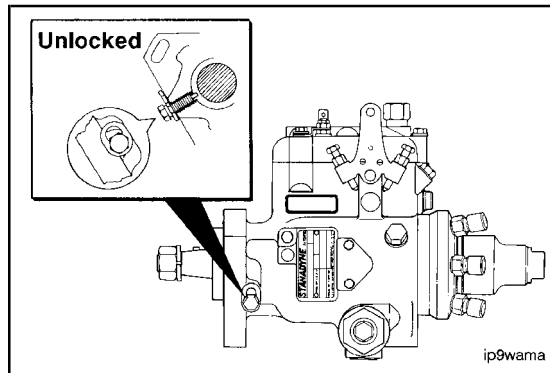

**8-mm Allen or 10-mm Hex**

On the Bosch® pump, the special washer is wired to the pump and **must** be installed under the lockscrew.

**Torque Value:** 13 N•m [115 in-lb]

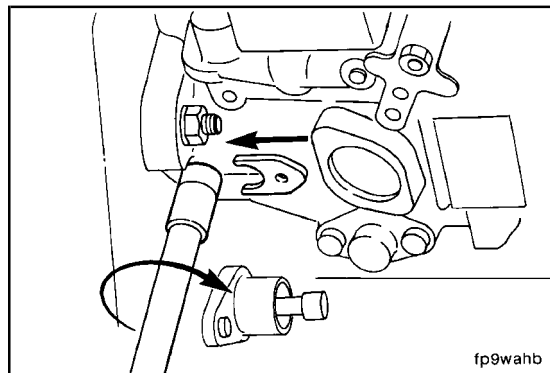

Disengage the timing pin before rotating the crankshaft.

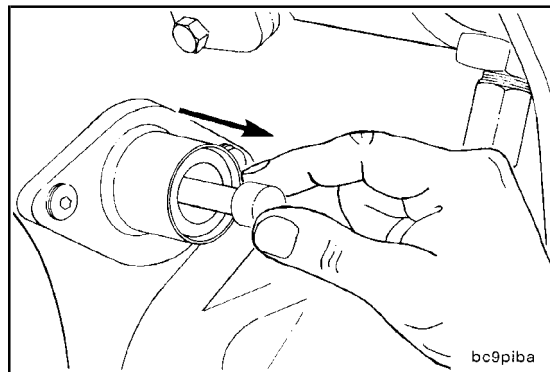

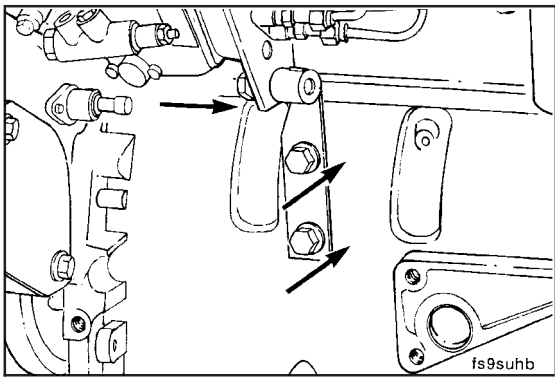

10 mm

Install the injection pump support bracket. Finger-tighten all capscrews before final tightening.



**NOTE:** Tighten the bracket to block mounting capscrew before tightening the bracket to injection pump capscrews.

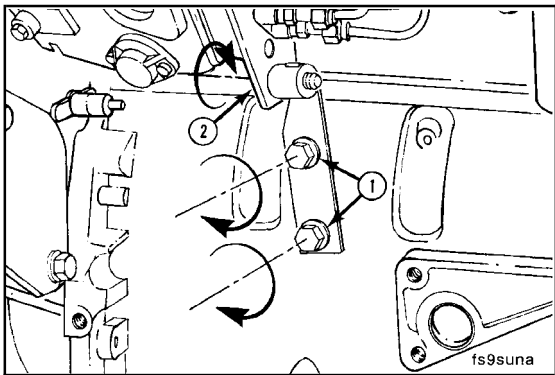

Tighten the bracket capscrews to the cylinder block (1). Tighten the tail support bracket capscrew to the fuel pump (2).

**Torque Value:** 24 N•m [18 ft-lb]

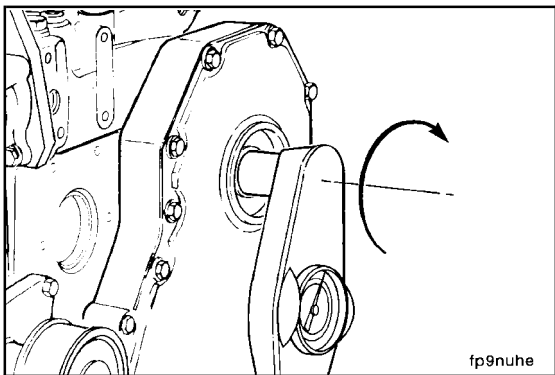

22 mm

Tighten the pump retaining nut.



**Torque Value:**

Bosch® VE (M14-1.5 nut)	98 N•m	[72 ft-lb]
Bosch® VE (M12 nut)	65 N•m	[48 ft-lb]
Lucas CAV/ DPA	81 N•m	[60 ft-lb]
Stanadyne	196 N•m	[145 ft-lb]

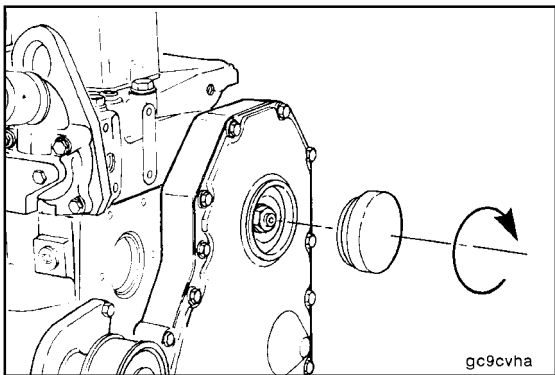

Install the access cap.

**B3.9 and B5.9 Series Engines**  
**Section 5 - Fuel System - Group 05**

**8 mm**

Install all high-pressure fuel lines and the electrical wire to the fuel shutoff valve.

Refer to Procedure 006-051 and 005-043.

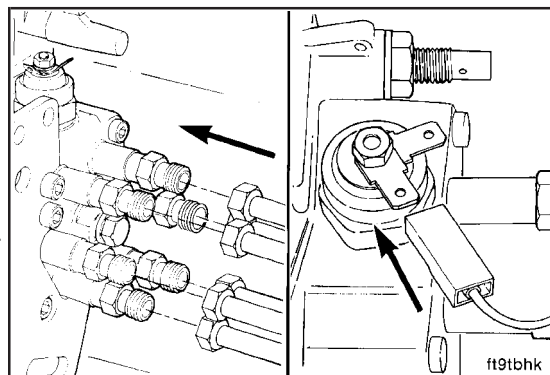

**12 mm and 1/2 Inch**

If required, install the air-fuel control tube.

Refer to Procedure 006-001.

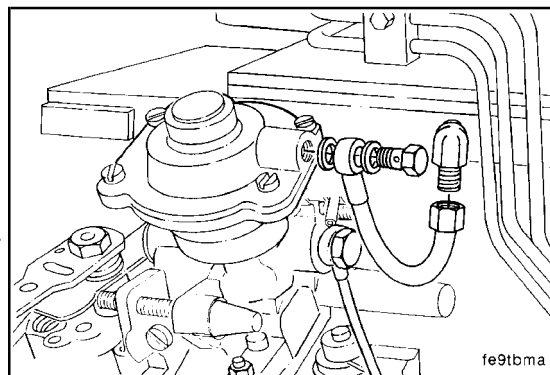

When connecting the cable and rod to the control lever, adjust the length so the lever has stop-to-stop movement.

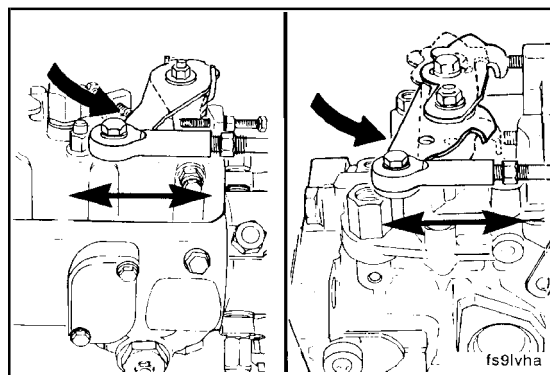

Adjust the length of the cable or rod to the mechanical shutdown lever so there is stop-to-stop movement.

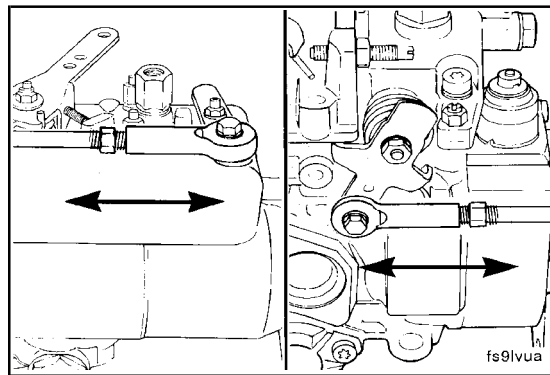

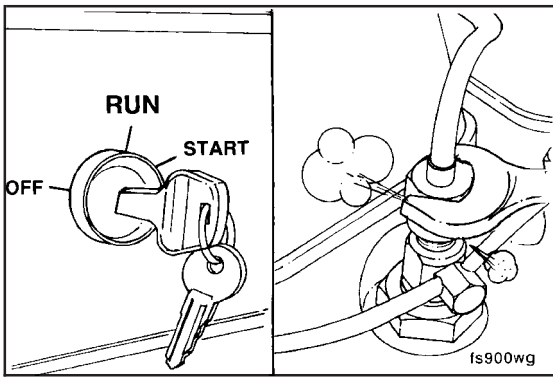

Bleed all air from the fuel system. Refer to Procedure 006-003.

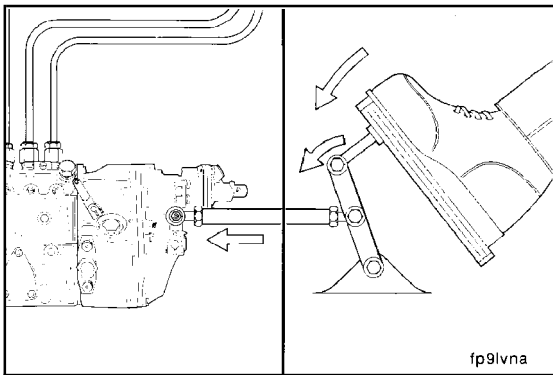

### Fuel Pump Control Lever and Spring (005-018)

#### Adjust (005-018-029)

The amount of fuel injected, and subsequently the speed and power from the engine, is controlled by the fuel control lever. Restricted travel of the lever can cause low power. **Always** check for full travel of the lever when diagnosing a low-power complaint.

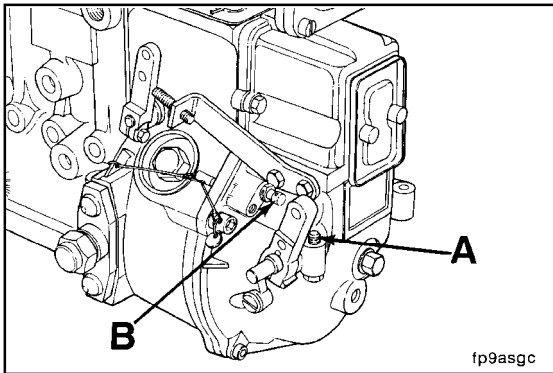

### Fuel Pump High Idle Speed (005-028)

#### General Information

##### Fuel Injection Pump Idle Adjustment Screws

The idle adjustment screw provides a stop for the lever at low speed. The adjustment screw can be used to increase idle speed for accessory loading or, if required, to lower the idle speed.

The high-speed screw is set at the factory and can **only** be adjusted at a certified fuel pump shop.

A - Idle Screw

B - High-Idle Screw.

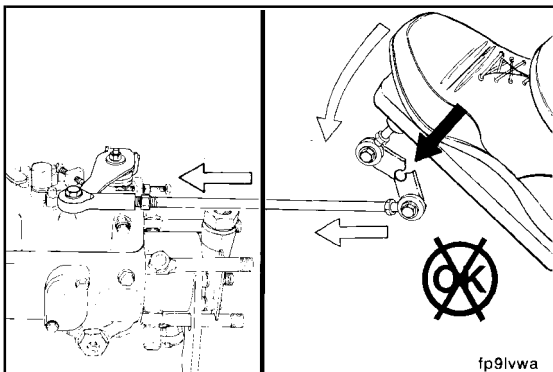

### Fuel Pump Idle Speed (005-029)

#### Adjust (005-029-029)

##### Fuel Control Lever Travel and Adjustment

The amount of fuel injected, and subsequently the speed and power from the engine, is controlled by the fuel control lever. Restricted travel of the lever can cause low power. **Always** check for full travel of the lever when diagnosing a low-power complaint.

**Stanadyne DB4 Fuel Injection Pump Adjustment Screw**

The low-idle adjustment screw on the DB4 fuel injection pump is mounted on the control lever assembly. The adjustment screw can be used to increase the idle speed to compensate for accessory loading. The low-idle adjustment screw **must** be adjusted by an authorized service dealer and resealed.

**NOTE:** Never turn the idle adjusting screw out (reduce idle speed) on the speed drop governor-equipped fuel injection pump; this can result in disengagement of the throttle lever from the guide bushing.

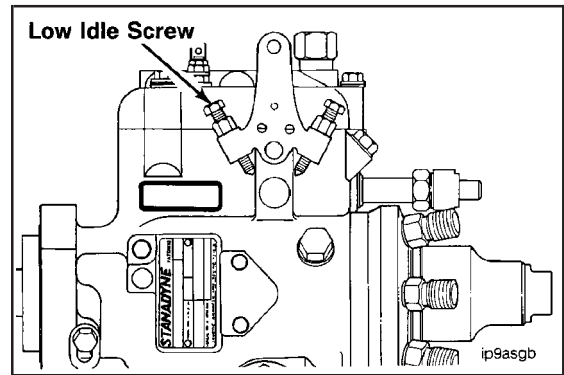

The high-idle adjustment screw (A) is sealed. The adjustment screw on the DB4 fuel injection pump is mounted on the control lever assembly. The high-idle adjustment screw **must** be adjusted by an authorized service dealer.

The speed droop adjustment screw (B) is located above the delivery head. The fuel pump governor sensitivity can be adjusted to increase or decrease governor regulation.

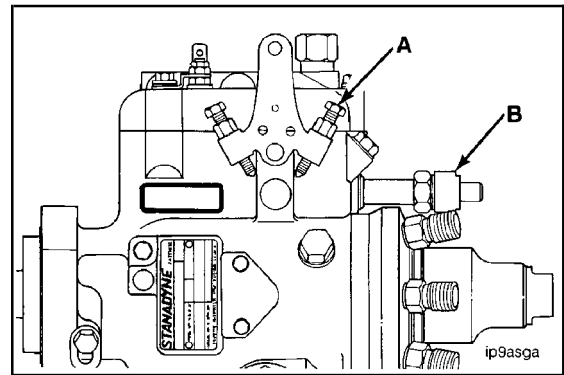

**Lucas CAV DPA/DPS Fuel Injection Pump Adjustment Screws**

The idle adjustment screw provides a stop for the lever at low speed. The adjustment screw can be used to increase idle speed for accessory loading, or, if required, to lower the idle speed. The high-idle screw is sealed and **must** be adjusted by an authorized repair shop, and then resealed.

- A - Idle screw
- B - High-idle screw

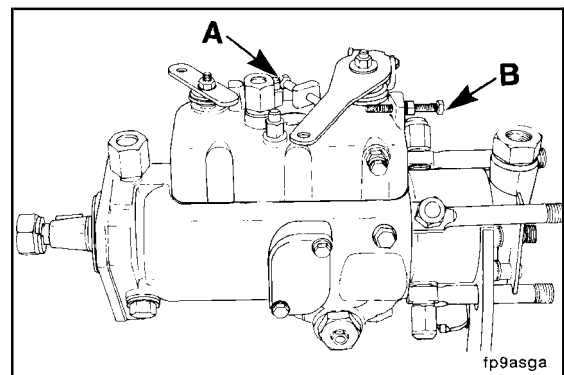

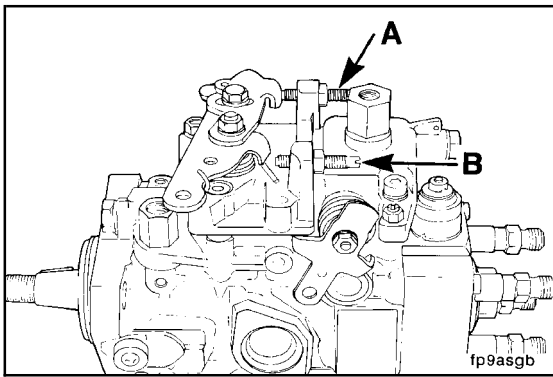

**⚠ CAUTION ⚠**

The fuel control lever on the Bosch® VE fuel injection pump is indexed to the shaft during pump calibration. If the lever has been removed and reinstalled incorrectly, engine speed and power will be affected.

**Bosch® VE Fuel Injection Pump Adjustment Screws**

A - Idle Screw

B - High-Idle Screw

The high-speed adjustment screw on both fuel injection pumps provides the stop for full speed. The high-speed adjusting screws are sealed. Adjustment of this screw **must** be performed **only** by an authorized fuel injection pump service center, and then resealed.

The high-speed adjusting screw can be used to derate engines.

**Bosch® RSV Governor**

Idle speed adjustment for industrial engines requires the setting of both the low-idle speed screw (1) and the bumper spring screw (2).

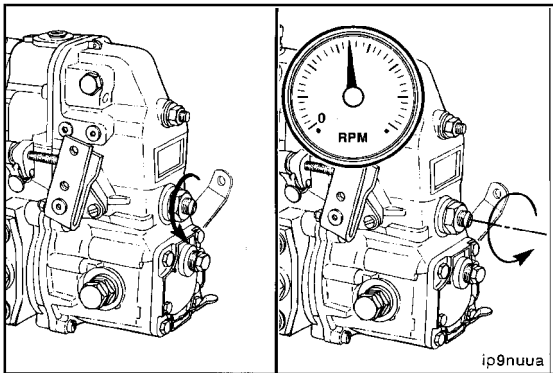
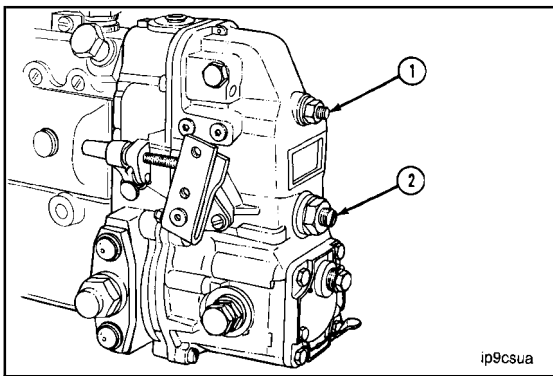

**19 mm, Screwdriver and Tachometer**

First, loosen the locknut; then, back out the bumper spring screw until there is no change in engine speed.



**13 mm, Screwdriver and Tachometer**

Loosen the locknut, and adjust the idle speed screw to 40 to 50 rpm less than the desired speed. Turn the idle speed screw **counterclockwise** to decrease rpm and **clockwise** to increase rpm.

Tighten the locknut.

**Torque Value:** 8 N•m [71 in-lb]

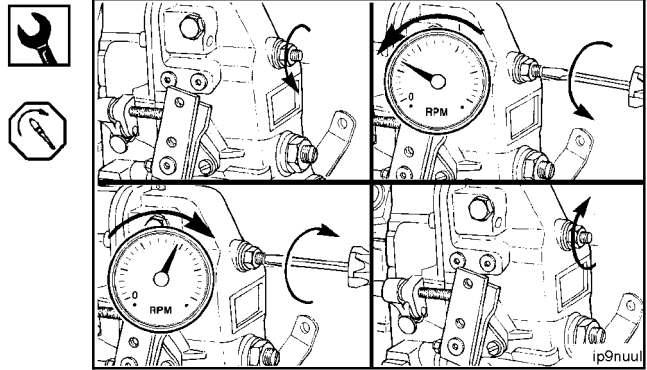

**19 mm, Screwdriver and Tachometer**

Turn the bumper spring screw **clockwise** until the desired idle speed is obtained.

Tighten the locknut.

**Torque Value:** 8 N•m [71 in-lb]

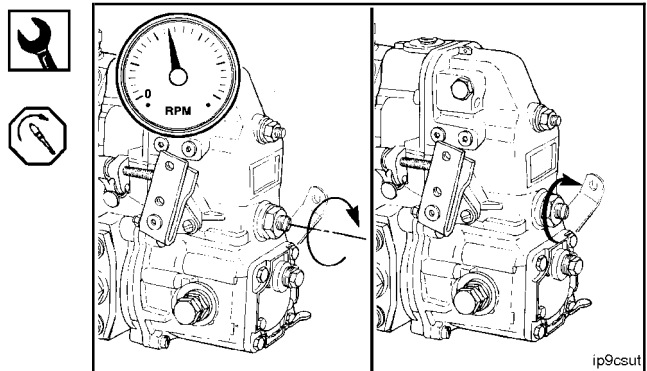

**Bosch® RQV and RQV-K Governor**

**8 and 10 mm, Screwdriver and Tachometer**

Idle speed adjustment on automotive fuel injection pumps requires setting of the stop screw.

Loosen the locknut, and turn the idle speed screw **counterclockwise** to increase the rpm and **clockwise** to decrease the rpm speed.

Tighten the locknut.

**Torque Value:** 8 N•m [71 in-lb]

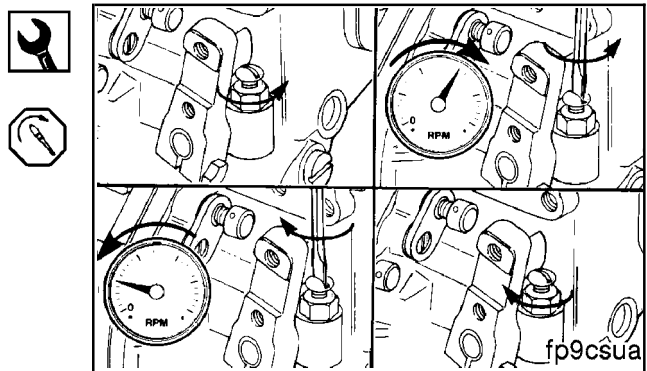

**⚠ CAUTION ⚠**

Do not reduce idle speed from factory setting on the Stanadyne DB4 fuel injection pump. Internal damage can result.

**Distributor Pumps**

**10 mm**

Loosen the adjusting screw locknut, and adjust the idle as required.

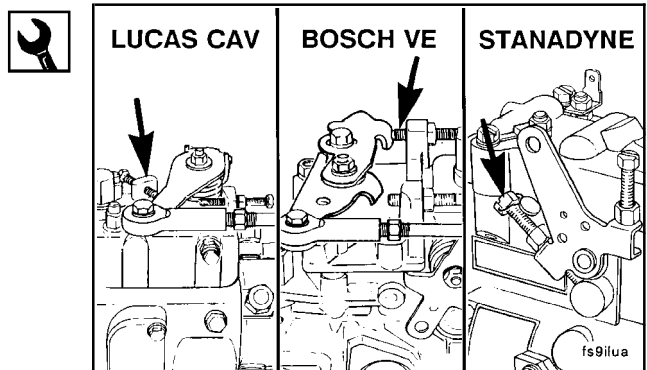

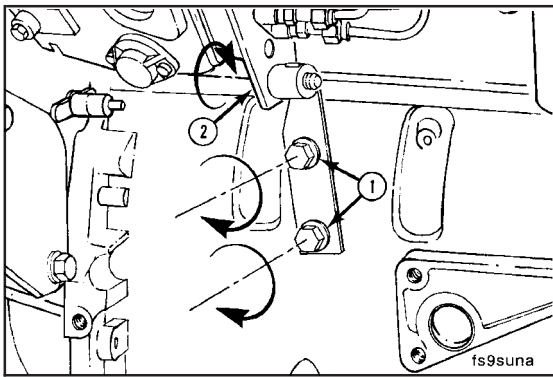

**Fuel Pump Support Bracket (005-033)**  
**Remove (005-033-002)**



**Rotary Pump**  
**10 mm**

Remove the cap screw that is connected to the pump and the tail support bracket (2) first; then remove the cap screws from the bracket (1) and block.

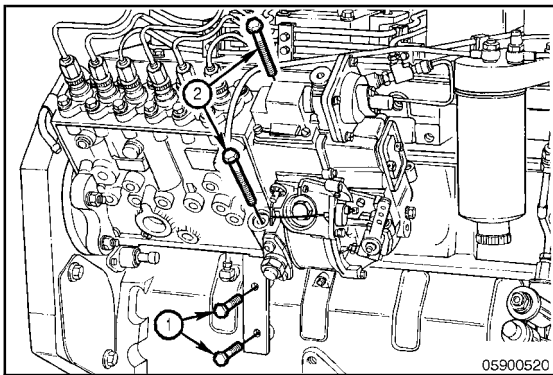

**In-Line Pump**  
**10 mm**



Remove the cap screw that is connected to the pump and the tail support bracket (2) first; then remove the cap screws from the bracket (1) and block.

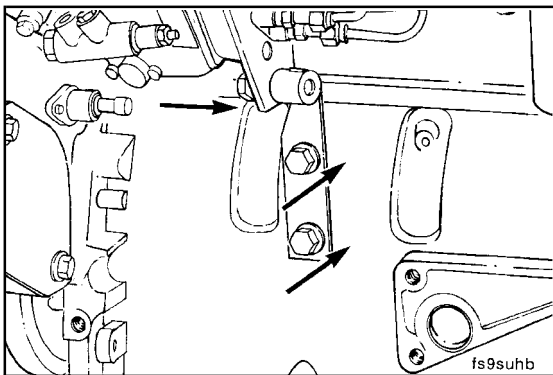

**Install (005-033-026)**  
**Rotary Pump**

Install the tail support bracket finger-tight before final tightening.

**NOTE:** Tighten bracket to block before tightening the bracket to the pump.

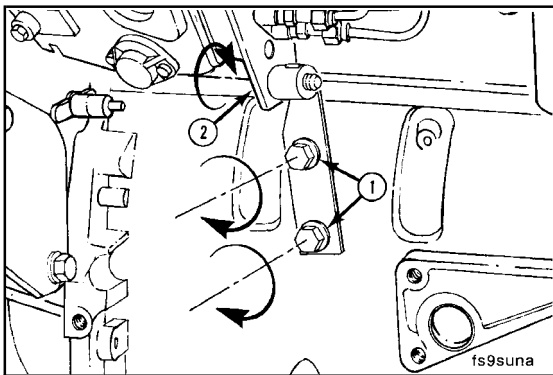

**10 mm**

Tighten cap screw and bracket to the injection pump (2) first; then the cap screws to the bracket and block (1).



**Torque Value:** 24 N•m [18 ft-lb]

**In-Line Pump**

Install the tail support bracket finger-tight before final tightening.

**NOTE:** Tighten bracket to block before tightening the bracket to the pump.

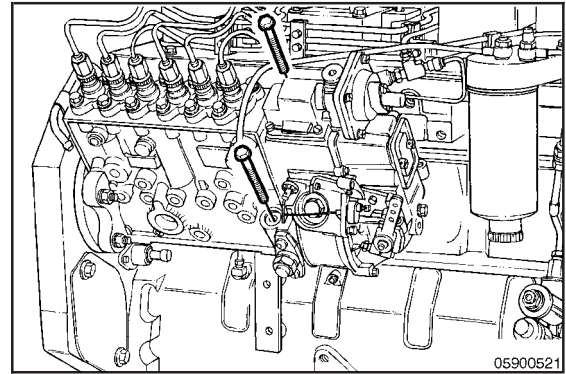

**10 mm**

Tighten bracket to the block (1) first; then to the injection pump (2).

**Torque Value:** 24 N•m [18 ft-lb]

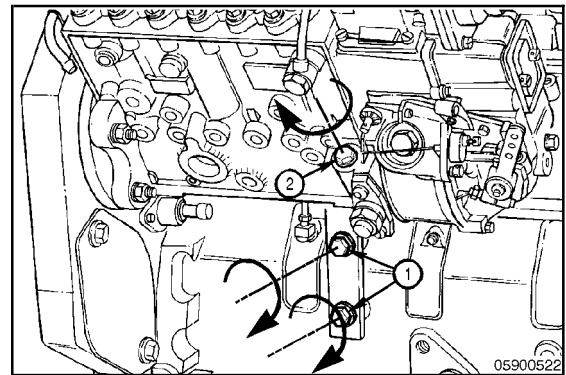

**Fuel Pump Timing (005-037)**

**General Information**

Pump-to-engine timing is extremely critical. Pump timing that is off by **only** a few crankshaft degrees will cause:

1. Poor performance - starting and power.
2. Excessive smoke and emissions.
3. Poor fuel economy.

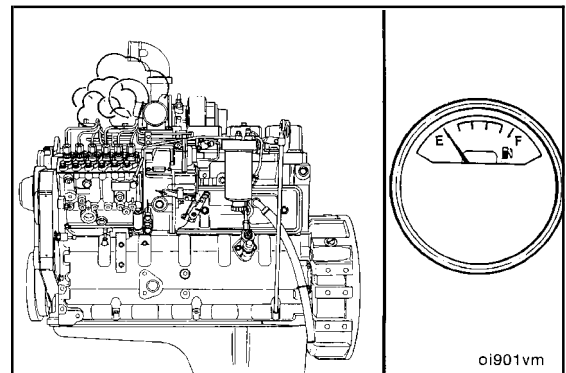

**Time (005-037-051)**

Engine pump timing begins with the timing of the fuel injection pump drive gear to the camshaft gear.

The first step is the location of TDC of the compression stroke for cylinder No. 1.

Then, depending on the engine configuration, a letter on the gear will, possibly, need to be aligned with the mark on the camshaft gear.

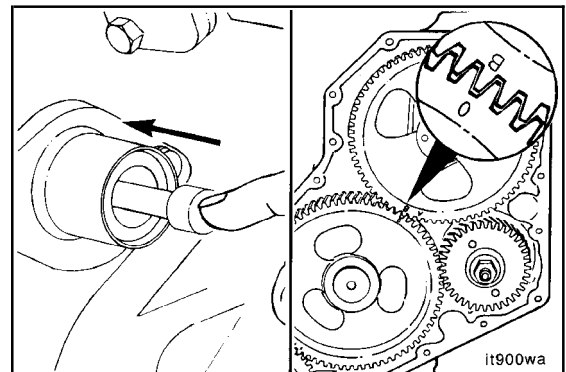

This table **must** be used to maintain proper fuel injection pump-to-engine timing. The critical parts list (CPL) number from the engine dataplate and the Control Parts List Manual, Bulletin No. 3379133-20, **must** be used to determine whether the engine is certified, and if so, what year and regulating agency (EPA or CARB).

Given this information, use the following table to determine which letter on the fuel injection pump drive gear is aligned with the camshaft gear.

**NOTE:** Timing mark alignment is **not** required for the Nippondenso EP-9 or Bosch® in-line drive gear.

Letter on Pump Gear	Engine Model	Injection Pump	Certification
A	4B3.9, 4BT3.9	Stanadyne pump	Noncertified
A	4B3.9, 4BT3.9, 4BTA3.9	Lucas CAV DPA pump	All noncertified
B	4B3.9, 4BTA3.9	Bosch® VE	1986, 1987 EPA, All pre-1986, All noncertified
C	6BT5.9, 6BTA5.9	Bosch® VE	1986, 1987 EPA, All pre-1986, All noncertified, CPL 600
D	6B5.9, 6BT5.9	Stanadyne	Noncertified
D	6B5.9, 6BT5.9, 6BTA5.9	Lucas CAV DPA	All noncertified
E	6BT5.9, 6BTA5.9	Bosch® VE	1986, 1987, 1988, 1989, 1990, 1991, 1992 CARB
F	4BT3.9, 4BTA3.9	Bosch® VE	1986, 1987, 1988, 1989, 1990, 1991, 1992 CARB, 1988, 1989, 1990, 1991, 1992 EPA
G	6BTA5.9	Lucas CAV DPA	All Fire Pumps
H	Not used at this time	N/A	N/A

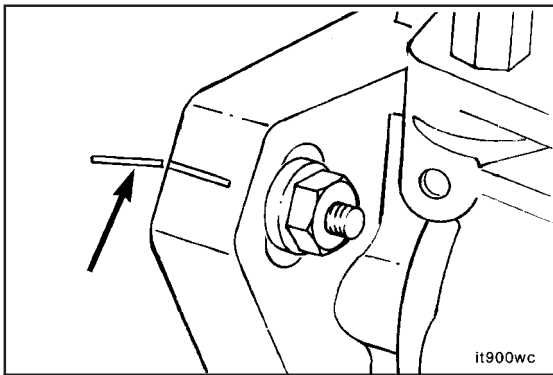

To verify that the fuel injection pump is timed correctly, first check the alignment marks on the pump flange and gear housing.

**NOTE:** One mm of rotation past the timing mark will advance or retard (depending on direction of rotation) the pump timing by 1 degree.

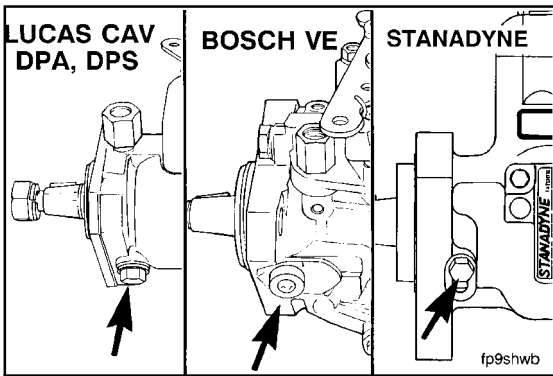

The Lucas CAV DPA, DPS, Stanadyne DB4, and the Bosch® VE fuel injection pumps all have a provision for locking the pump shaft at a position corresponding to top dead center for cylinder No. 1. New and reconditioned fuel injection pumps should be received with the shafts located in this position.

At the point of injection, the keyway of the shaft will align with the delivery valve receiving the injection and the illustrated hash mark on the seal housing.

**NOTE:** The illustrated mark is for reference **only** and should **not** be used for setting the fuel injection pump timing.

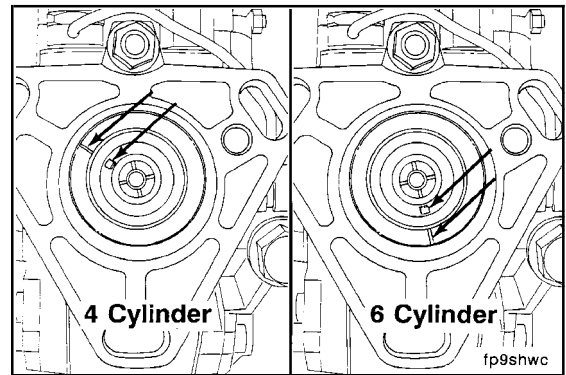

The No. 1 cylinder delivery valve is marked as illustrated.

Four cylinder = A

Six cylinder = D

Firing Order	
Four Cylinder	Six Cylinder
A = 1	D = 1
B = 3	E = 5
C = 4	F = 3
D = 2	A = 6
	B = 2
	C = 4

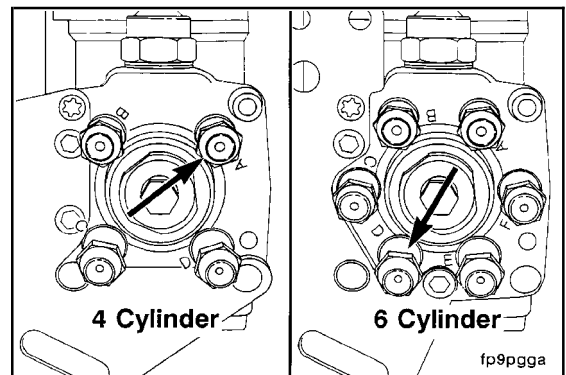

The engine is equipped with an engine timing pin to locate top dead center (TDC) for cylinder No. 1.

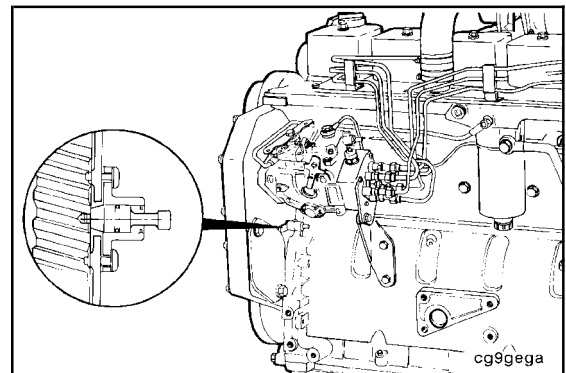

**⚠ CAUTION ⚠**

**If the timing pin is incorrectly located on the gear housing, the pump will not be timed correctly.**

After precisely locating TDC for cylinder No. 1, the factory positions the timing pin assembly to the gear housing using the timing pin and the hole in the camshaft gear. If the gear housing or timing pin assembly are removed, the same precision is required to relocate it.

If the timing pin assembly is incorrectly located, reposition the timing pin.

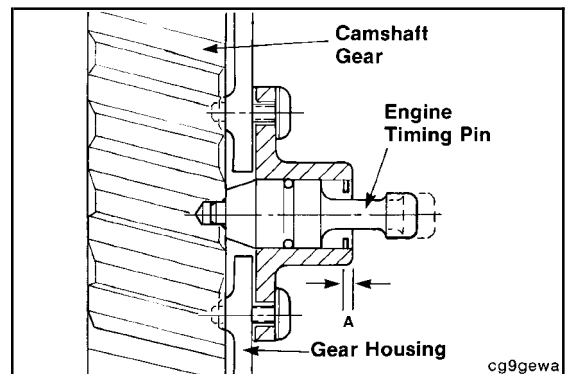

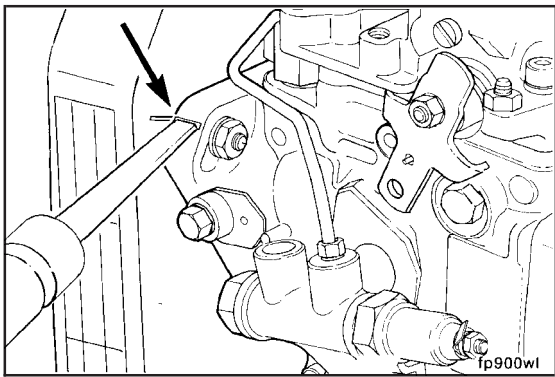

The flange of a replacement pump **must** be marked to align with the mark on the gear housing after installation.

During production, after the locked pump is fitted to the engine with cylinder No. 1 at top dead center (TDC), a mark is stamped on the gear housing and the pump flange. Thereafter, when these marks are aligned the pump is correctly timed to the engine.

**NOTE:** The marks on the gear housing and the pump flange are unique to each engine.

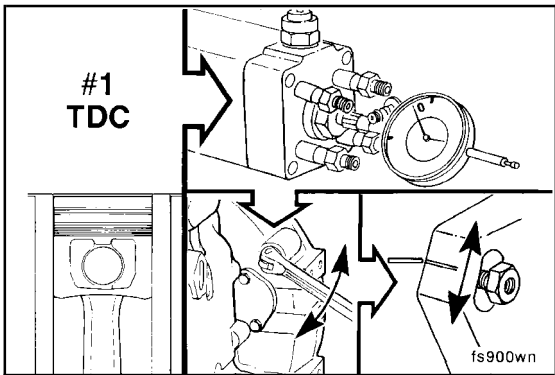

**Bosch® Timing Tool (VE pump), Part No. 3377259**

A special indicator can be used to measure the position of the Bosch® VE fuel injection pump plunger to check pump timing.

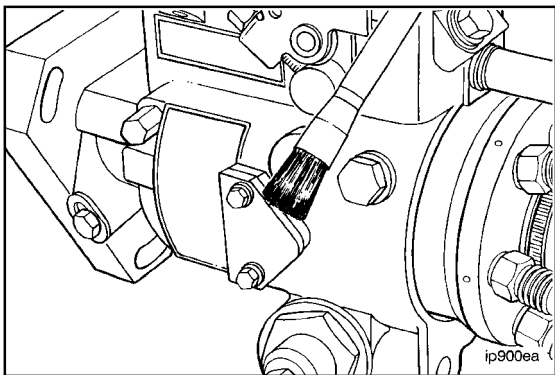

**Stanadyne DB4 Fuel Injection Pump Timing**

Clean all debris from around the fuel injection pump timing window cover.

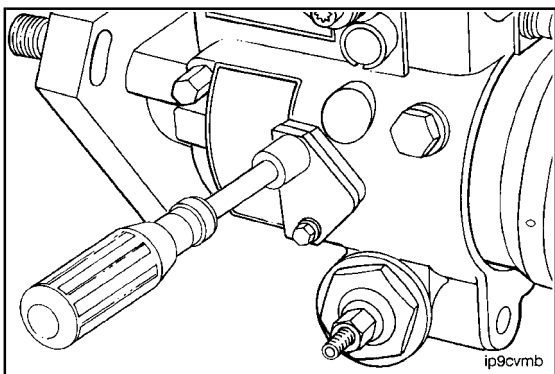

Remove the fuel injection pump timing cover.

**B3.9 and B5.9 Series Engines  
Section 5 - Fuel System - Group 05**

Rotate the fuel injection pump driveshaft in the direction of pump rotation to align the timing line on the weight retainer hub with the line on the cam ring.

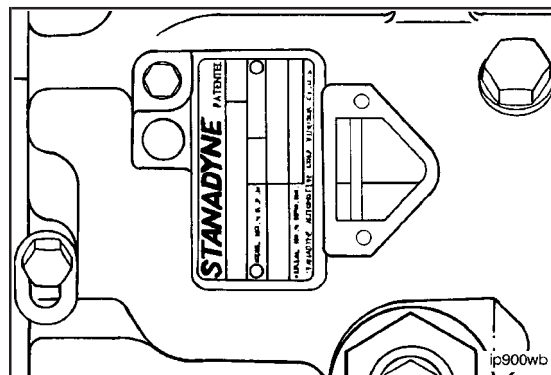

Position the fuel injection driveshaft locking key plate in the locked position. Turn the locking screw in until contact is made with the driveshaft.



**Torque Value:** 11.9 N•m [105 in-lb]

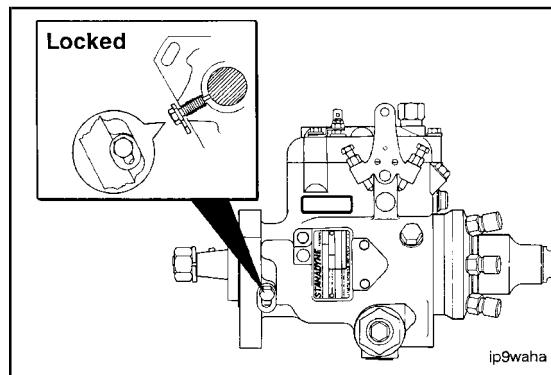

Verify the timing marks are aligned after lock timed.

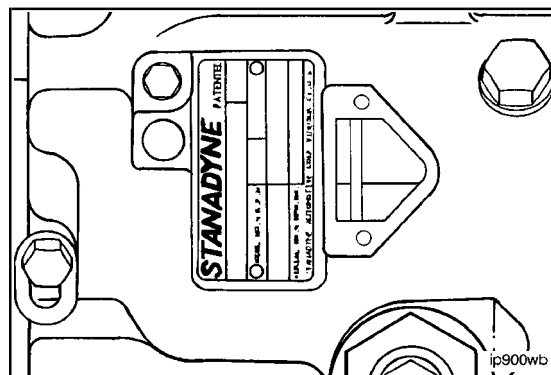

Install the fuel injection pump timing cover.

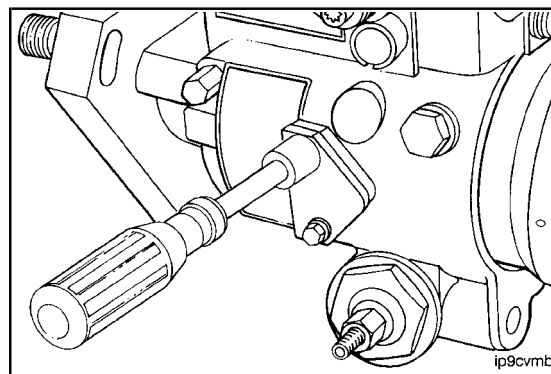

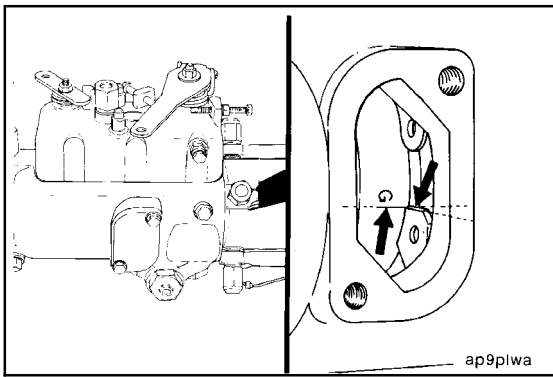

ap9plwa



**CAV DPA/DPS Fuel Injection Pump Timing**

Correct timing of the Lucas CAV DPA/DPS fuel injection pump can be verified by removing the inspection plate.

**NOTE:** Special equipment in an authorized shop is required to time the Lucas CAV DPA fuel injection pump precisely. However, for troubleshooting and in an emergency, visual alignment of the timing mark is close enough for the engine to run.

Both of these checks are described in the fuel injection pump replacement. Refer to Procedure 005-012 or 005-014. Refer to Procedure 005-013 for installation of the timing pin.

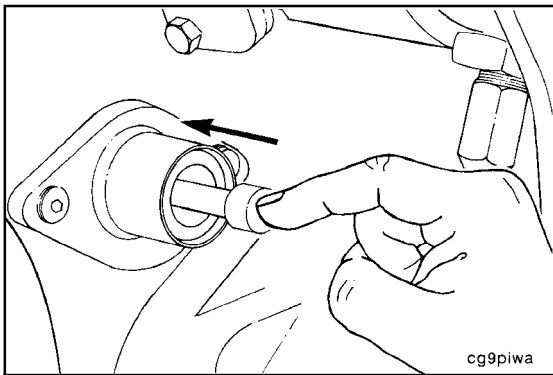

cg9piwa

**Timing Check - (Bosch® VE Pump)**

Rotate the crankshaft to top dead center (TDC).

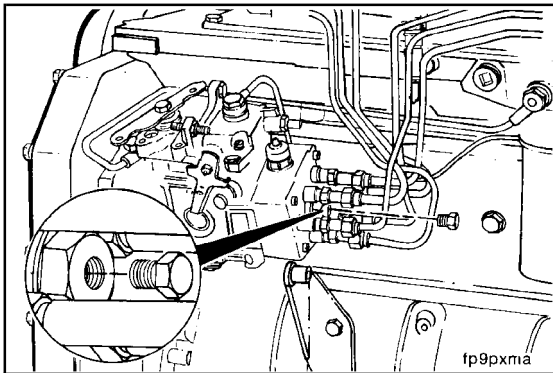

fp9pxma



**12 mm**

Remove the plug from the end of the pump.

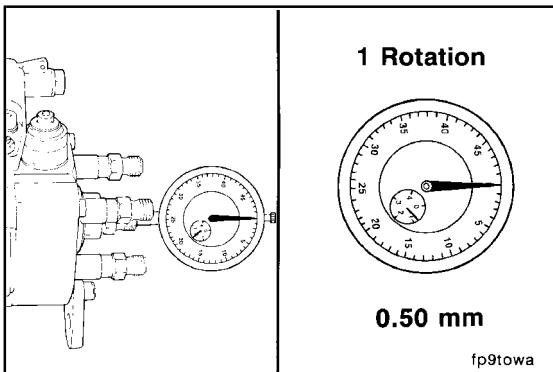

fp9towa



**CAUTION**

Do not bend the fuel lines. Doing so can result in fuel system failure.



**Bosch® Timing Tool (VE pump), Part No. 3377259**

Install the timing indicator. Be sure to allow adequate travel for the indicator.



In order to install the timing indicator, it is often necessary to disconnect one or more of the fuel lines from the fuel pump.

**NOTE:** The indicator is marked in increments of 0.01 mm. One revolution of the indicator needle is equal to 0.50 mm.



**B3.9 and B5.9 Series Engines**  
**Section 5 - Fuel System - Group 05**

**Fuel Pump Timing (005-037)**  
**Page 5-67**

Bar the crankshaft in the direction opposite engine rotation until the indicator needle stops moving. Adjust the indicator face to read zero.

Rotate the crankshaft back to top dead center (TDC), and count the number of revolutions of the indicator needle. The reading shown when the engine timing pin engages is the amount of plunger lift the pump has at that point.

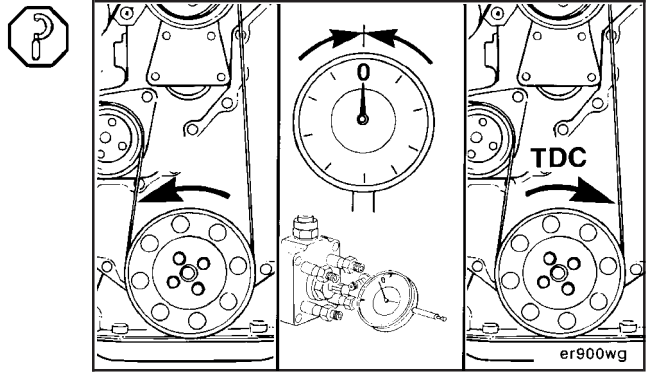

**13 mm**

Rotate the pump on the mounting studs until the indicator reads the correct value for plunger lift. This illustration gives an example of the indicator readings for the various plunger lift values.

Tighten the flange-mounting nuts.

**Torque Value:** 24 N•m [18 ft-lb]

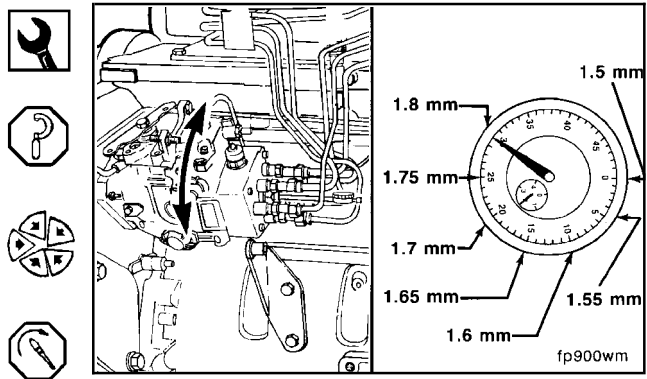

**12 mm**

Remove the timing indicator. Install the plug.

**Torque Value:** 10 N•m [89 in-lb]

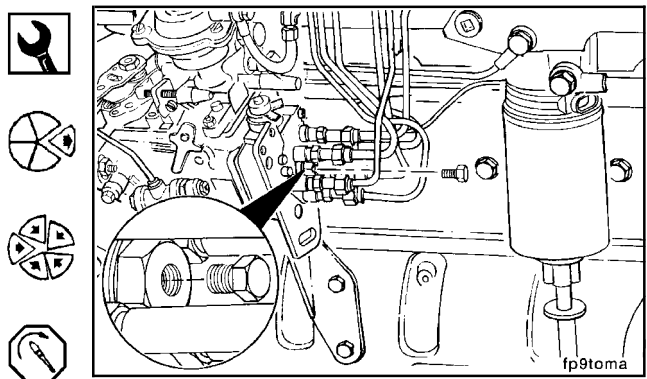

**Pump Timing - Lucas CAV DPA, Stanadyne DB4, Nippondenso EP-9, and Bosch® P7100**

Rotate the engine to top dead center (TDC).

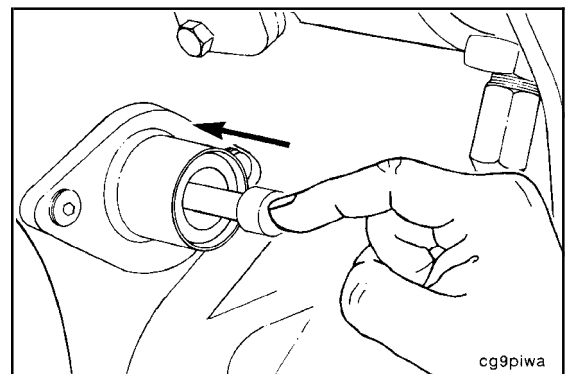

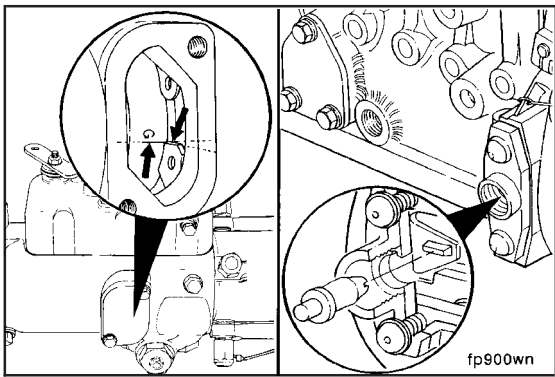

Correct timing of the Lucas CAV DPA and Stanadyne DB4 fuel injection pump can be verified by removing the timing window cover plate.

The Nippondenso EP-9 and Bosch® P-7100 fuel injection pumps are checked by removing the timing pin access plug and verifying the slot in the pin will fit over the timing tooth in the fuel injection pump.

**NOTE:** Special equipment in an authorized shop is required to time the Lucas CAV DPA fuel injection pump precisely. However, for troubleshooting and in an emergency, visual alignment of the timing mark is close enough for the engine to run.

To correct the timing on the Bosch® P-7100 and Nippondenso EP-9, refer to the replacement procedure for the respective pump.

Two injection pump timing marks are used on the Stanadyne DB4 for timing injection of fuel into the No. 1 cylinder. One mark is located on the governor weight retainer hub. The other is located on the internal cam ring. These two marks **must** be aligned at No. 1 cylinder top dead center (TDC).

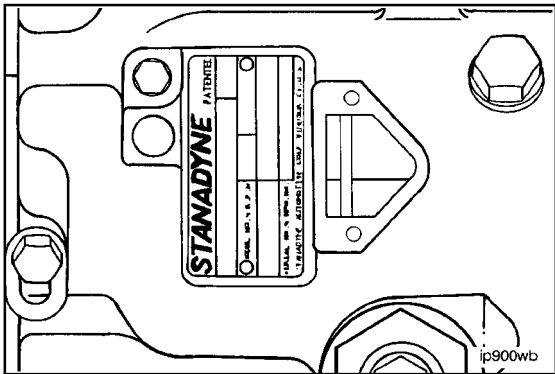

Manufactured in U.S.A. for: Cummins Engine Company, Inc. Box 3805 Columbus, Indiana 47202-3005	Cyl. ID: 3.9 Cyl. Sp. L: 3.9 Series: B 0591	Engine Serial No.: 44005065 Injector P/N: 3903383 Cust. Spec.:
	Timing-TDC: Letter G Valve lash code: 0.010 In. 0.020 In.	Fitting Order: 1-3-4-2 Low Idle RPM: 750 E.C.S.:
Warning: Injury May Result and Warranty is Voided if Fuel Rate RPM or Attributes Exceed Published Maximum Values for This Model and Application. Date of Mfg: 4/27/83		

On the Lucas CAV DPA, the correct timing letter can be located on the engine dataplate as shown.

The letter G indicated refers to the correct timing letter alignment as shown in the previous frame.

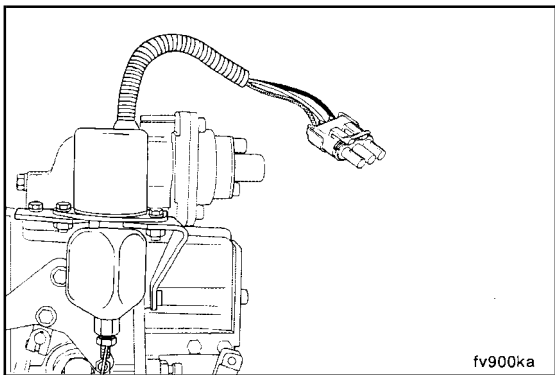

## Fuel Shutoff Valve (005-043)

### General Information

#### Shutdown Solenoid (In-Line-Type Injection Pump)-Troubleshooting

Engines using the in-line type of injection pumps are equipped with the synchro-start fuel shutoff solenoid to actuate the shutoff lever. Both 12-VDC and 24-VDC external fuel shutoff solenoids are available.

**B3.9 and B5.9 Series Engines  
Section 5 - Fuel System - Group 05**

**Fuel Shutoff Valve (005-043)  
Page 5-69**

The synchro-start has a Weather-Pack connector with three wires in it.

Color	Description	Weather-Pack Port
Black	Ground	C
White	Pull In	B
Red	Hold In	A

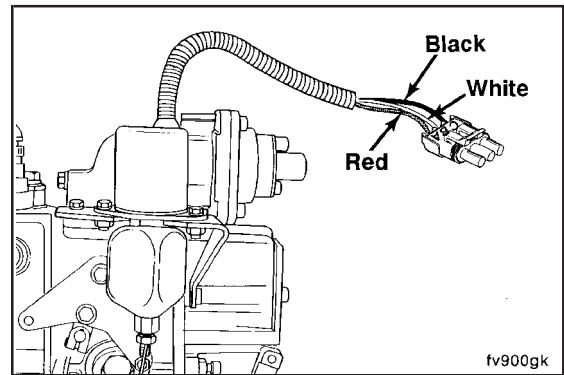

**Wiring Guidelines:**

Refer to the chart below to find the correct gauge size and length of continuous wire for the white (pull-in) wire, which connects to the solenoid wiring.

This is the total wire length from the battery to the solenoid and back to the battery. Both white and black wire length **must** be added.

Gauge	Length of Wire		
	Maximum Length in Feet	12 VDC	24 VDC
14	0 to 137	5	9
12	0 to 213	9	14
10	0 to 335	14	23

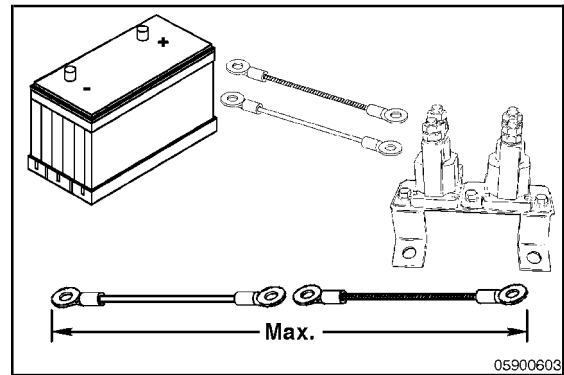

**NOTE:** Fourteen-gauge wire is required for the red (hold-in) wire, which connects to the "Run" terminal on the ignition switch.

**NOTE:** The black (ground) wire **must** be the same size as the white (pull-in) wire.

**Preparatory (005-043-000)**

8 mm

**Bosch® VE**

Remove the electrical wire, and complete the following steps.

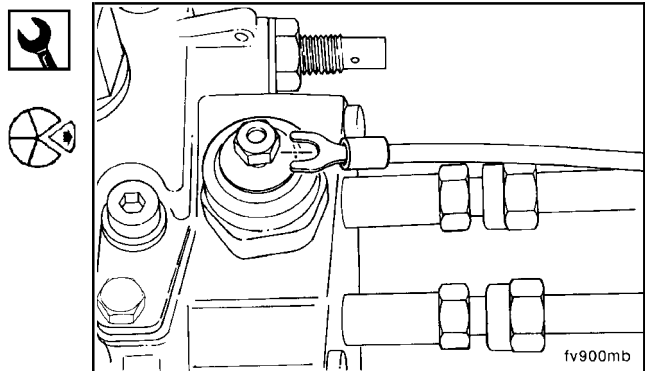

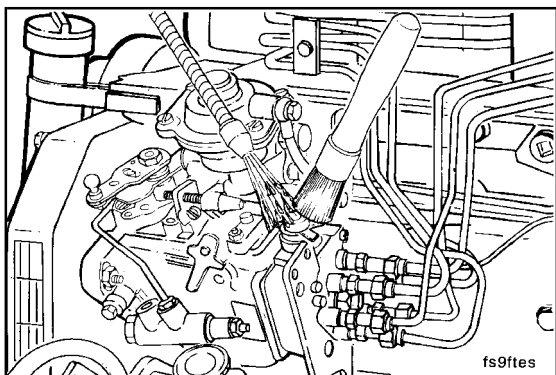

**Bosch® In-Line-Type Fuel Pump**

Clean around the valve.



Label and disconnect the wiring.

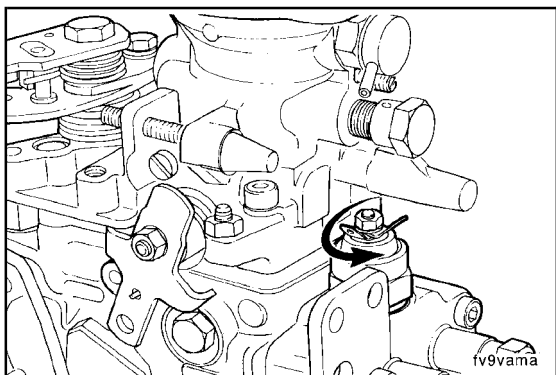

**Remove (005-043-002)**

24 mm



**Bosch® VE**

Remove the valve.

**NOTE:** The Bosch® VE valve is shown. The valve for Lucas CAV is located at the bottom of the pump.

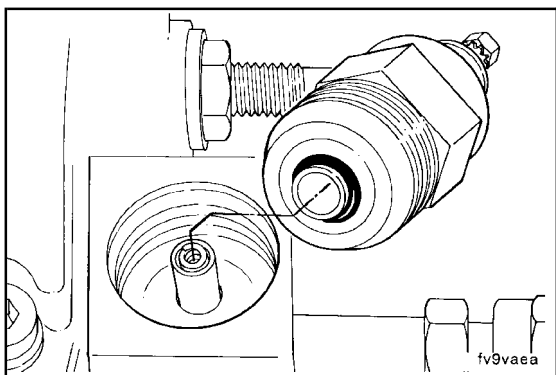

**⚠ CAUTION ⚠**

When removing the valve, be careful not to drop the plunger and spring. Doing so can result in fuel pump damage.

Stanadyne DB4

Tamper-Resistant Screw Removal Tool, Part No. 3399870

- Remove the electrical wiring.
- Remove the fuel drain line. Refer to Procedure 006-021.
- Remove the throttle and shutoff linkage. Refer to the OEM service manual.
- Remove tamper-resistant screws using service tool kit (Cummins Part No. 3399870). Refer to Procedures 005-012 or 005-014.
- Remove the fuel injection pump top cover. Refer to the Master Repair Manual, Injector Pumps and Injectors, Bulletin No. 3666037.
- Disassemble the fuel injection pump top cover. Refer to the Master Repair Manual, Injector Pumps and Injectors, Bulletin No. 3666037.

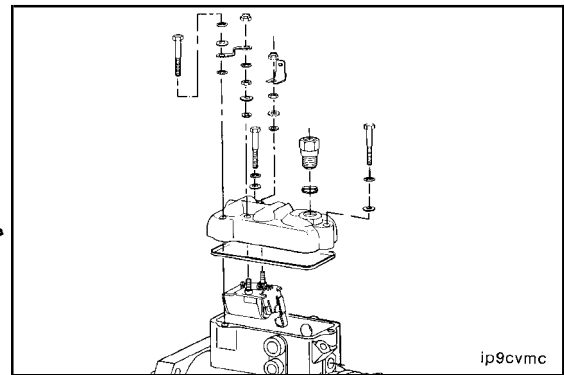

ip9cvmc

Test (005-043-012)



**Wear protective clothing to avoid personal injury. Solenoid surface temperature can exceed 175°C [347°F], which can cause serious burns to the skin in the event of contact.**

Solenoid Resistance Check

**NOTE:** Values are taken at 20°C [68°F] and rated voltage. Minimum values are for 25-mm [1.00-in] maximum plunger travel. As the temperature of the solenoid increases, the voltage and resistance requirements increase, while the amperage requirements decrease.

The solenoid resistance can be checked using a multimeter. Disconnect the wiring harness, and check the solenoid resistance.

Synchro start solenoids with a 44.45-mm [1.75-in] diameter coil canister.

Solenoid Voltage	Acceptable Resistance Range in Ohms	
	Pull-in	Hold-in
12	(0.198 to 0.242)	(10.00 to 12.21)
24	(0.738 to 0.902)	(37.17 to 45.43)

Synchro-start solenoids with a 50.8-mm [2.00-in] diameter coil canister.

Solenoid Voltage	Acceptable Resistance Range in Ohms	
	Pull-in	Hold-in
12	(0.175 to 0.213)	(12.75 to 15.56)
24	(0.554 to 0.678)	(46.76 to 57.15)

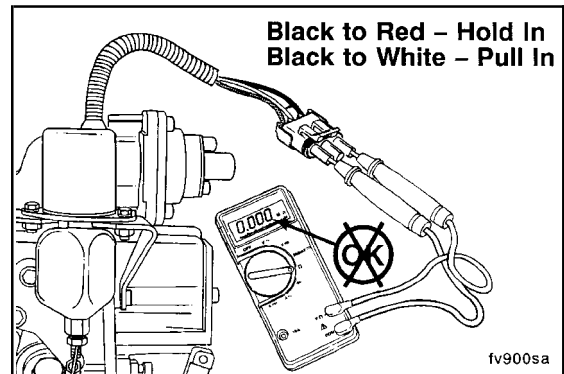

fv900sa

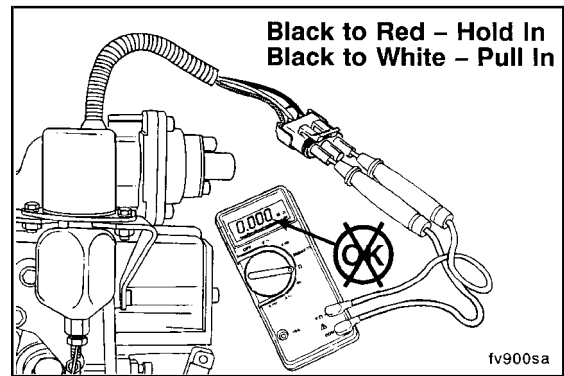

fv900sa

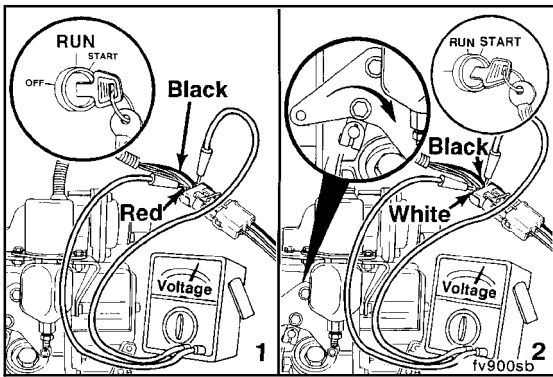

**Voltage Check**

To perform the solenoid voltage check, connect the wiring harness, and apply voltage to the solenoid with the ignition key as follows:

1. With the key in the RUN position, check the hold-in voltage.
2. With the shutdown lever held in the shutdown position, move the key to the START position, and check the pull-in voltage.

Refer to the table for synchro start voltage specification with solenoid at 20°C [68°F]. Voltage requirements will be higher as engine temperature rises; therefore, these values are **only** valid with the solenoid at normal ambient temperatures.

Solenoid Voltage	Minimum Voltage	
	Pull-in	Hold-in
12	8.5	5.2
24	17.0	9.4

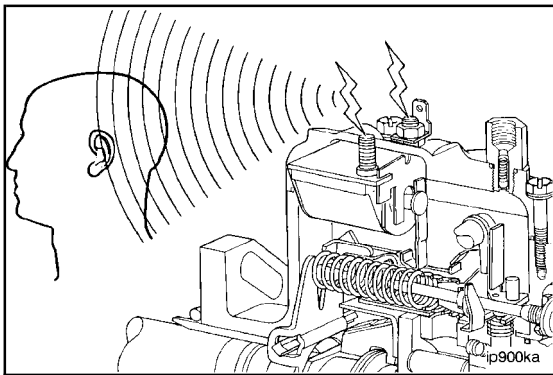

**CAUTION**

**Do not check energize-to-run solenoid operation with governor cover removed from the fuel injection pump.**

Test the shutdown solenoid on the Stanadyne DB4 fuel injection pump by applying an electrical current to the terminals and listening for a "click." If a solid "click" is heard, the solenoid is operating freely.

Use the following values to check energize-to-run solenoids with an ohmmeter:

VDC	Stanadyne DB4 Solenoid	
	VDC	VDC to Energize (Minimum)
12		8.8
24		17.6

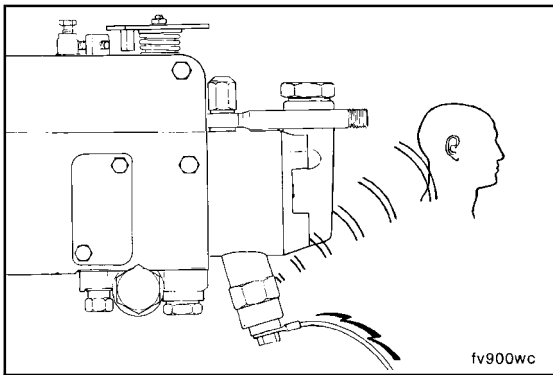

When the valve on the Lucas CAV DPA/DPS pump opens, a "click" can be heard.

Use the following values to check the solenoid with an ohmmeter.

VDC	CAV Solenoid Values	
	Resistance Ohms	VDC to Energize (Minimum)
12	9 @ 22°C [71.6°F]	9
24	36 @ 22°C [71.6°F]	18

The Bosch® valve does **not** make a very loud sound when actuated, but it can be checked with an ohmmeter for the following values:

Bosch® Shutdown Values	Resistance Ohms	Peak Amperes
12 VDC	7.4 + 0.5	2
24 VDC	29.5 + 2.5	1

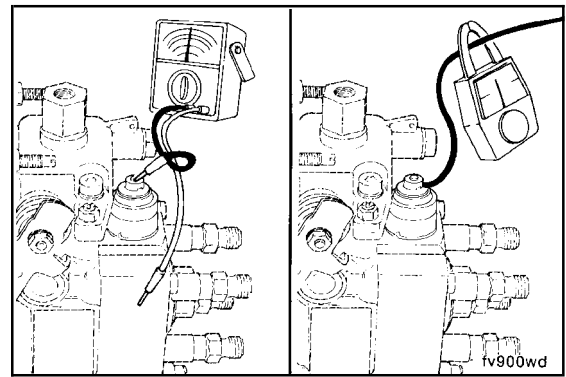

**⚠ CAUTION ⚠**

Do not connect the electrical wire to the solenoid when the plunger has been removed. Without the plunger, the valve can be damaged.

Malfunctioning valves and electrical wiring to the valve can be diagnosed by removing the plunger and spring, and then reinstalling the solenoid.

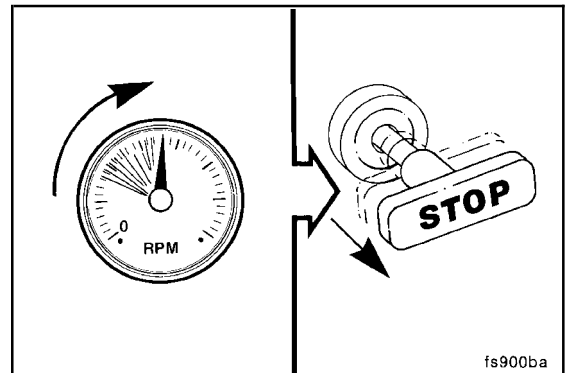

If the engine will start without the valve, the valve or the wiring to the valve is malfunctioning.

This method of removing the plunger to start the engine can be used, if necessary, to move the equipment to a service location.

**NOTE:** Use the mechanical shutdown lever to stop the engine.

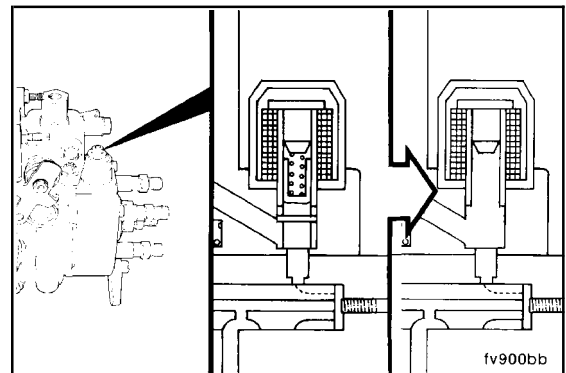

**Delivery Valves (Back Leakage Valves on Lucas CAV Pumps)**

There is a valve for each discharge tube. The purpose of the valve is to control the residual pressure in the high pressure line. A malfunctioning valve will cause an imbalance of the residual pressure resulting in rough engine operation or surging.

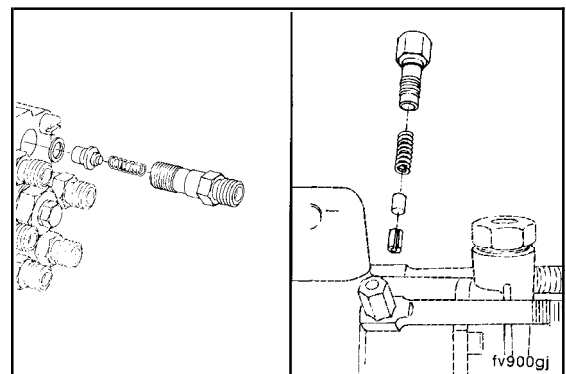

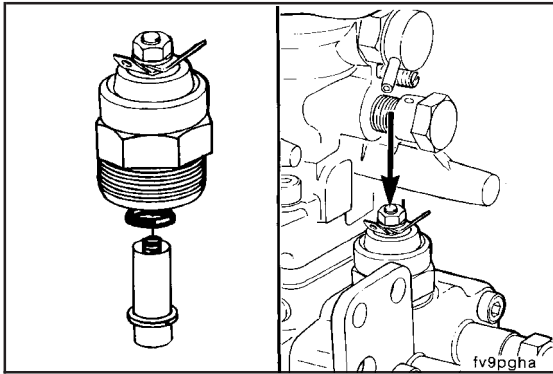

**Install (005-043-026)**

**Bosch® VE**

“Package” the solenoid, o-ring, spring, and plunger.

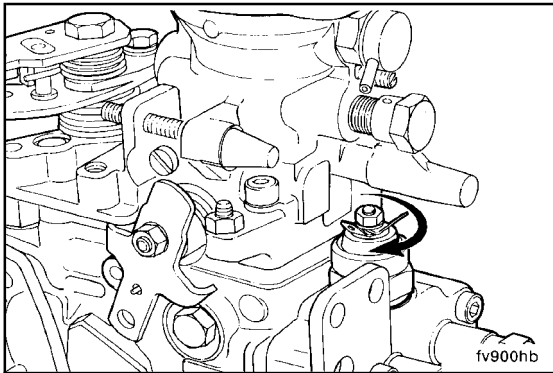

**24 mm**

Tighten the solenoid securely.

Connect the electric wire.



**Torque Value: 43 N•m [32 ft-lb]**

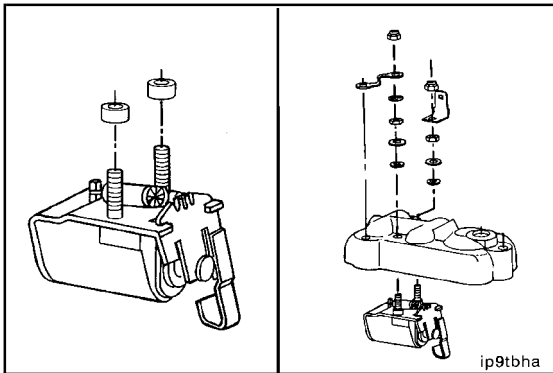

**5/16 Inch**

**Stanadyne DB4**

Install new insulating tubes onto the terminals on the terminal studs of the new solenoid.

Install the valve into the cover.

**Torque Value: 14 N•m [124 in-lb]**

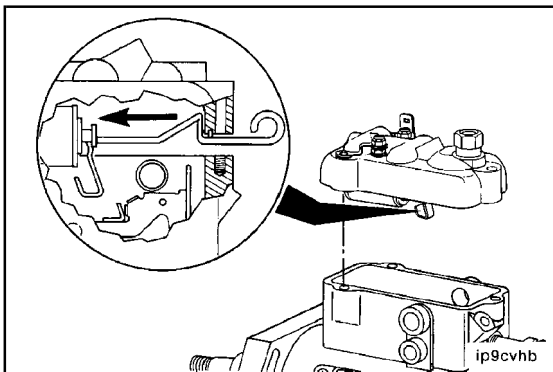

**5/16 Inch**

Install the cover and gasket onto the fuel injection pump.

With the tool installed as shown, place the cover in position on the pump housing. Twist the tool to release it, and slide it out from between the cover and the housing.

**NOTE:** Extreme care **must** be taken in assembling the cover to a fuel injection pump to make sure the shutoff arm is in proper contact with the linkage hook tab.





**B3.9 and B5.9 Series Engines**  
**Section 5 - Fuel System - Group 05**

In the event that the service tool is **not** available, the governor cover should be installed as follows:

Move the shutoff lever to the stop position.

Install the cover to pump at a downward angle from the drive shaft end of the fuel injection pump; then slide the cover horizontally into position.

**Torque Value:** 4.6 N•m [41 in-lb]

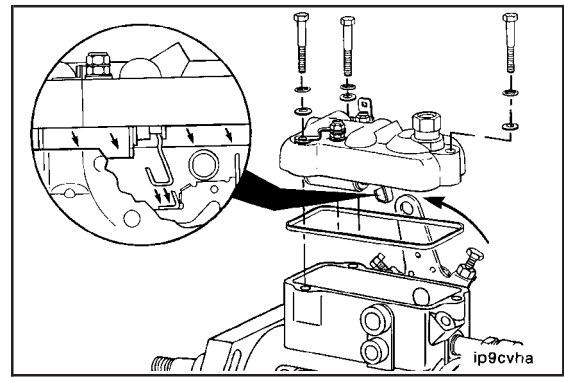

**Fuel Lift Pump (005-045)**

**Preparatory (005-045-000)**

- Clean debris from the fuel line fittings and the fuel transfer pump.
- Disconnect the low-pressure fuel lines. Refer to Procedure 006-024.

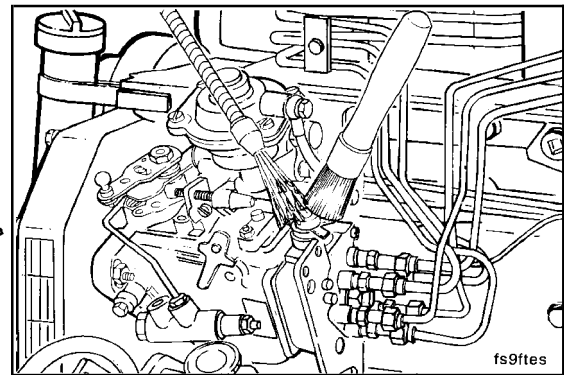

**Remove (005-045-002)**

10 mm

**Diaphragm Style**

Remove the fuel transfer pump, and complete the following steps.

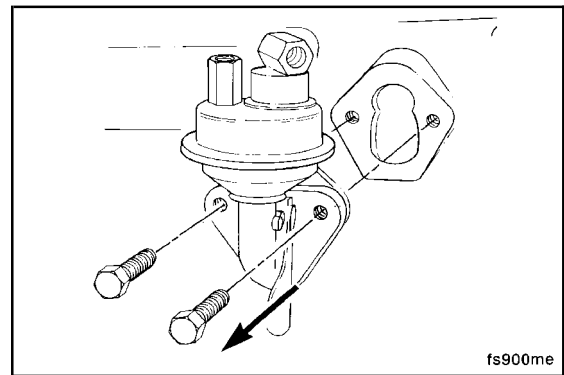

14 mm, 17 mm, 20 mm

**Fuel Transfer Pump (Piston Style)**

Disconnect the fuel line from the fuel transfer pump and fuel filter head.

Use two wrenches to disconnect the fuel line from the fuel transfer pump.

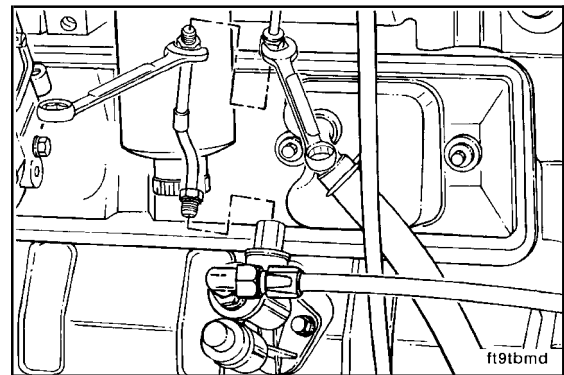

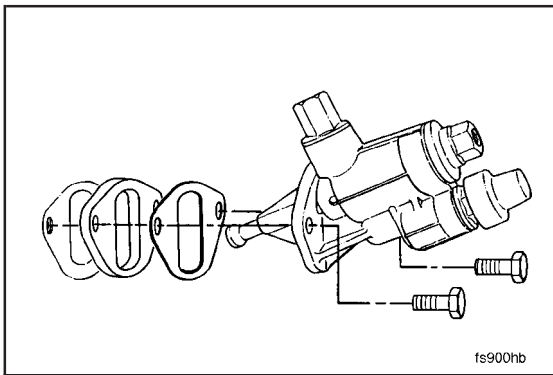

10 mm

Remove the fuel transfer pump.

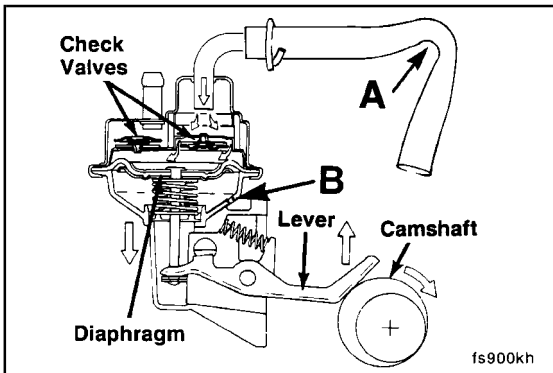

**Test (005-045-012)**

**Fuel Transfer Pump (Diaphragm Style)**

A malfunctioning fuel transfer pump can cause low power from the engine. The diaphragm-style pump can **not** be cleaned and rebuilt.

The transfer pump is mechanically driven by a lobe on the camshaft. Wear on the lever or a damaged lobe can reduce the pumping action.

**(A)**-Do **not** operate the fuel system with a suction restriction of more than 100 mm Hg [4 in Hg].

If the diaphragm ruptures, fuel will drain from the weep hole **(B)** in the housing.

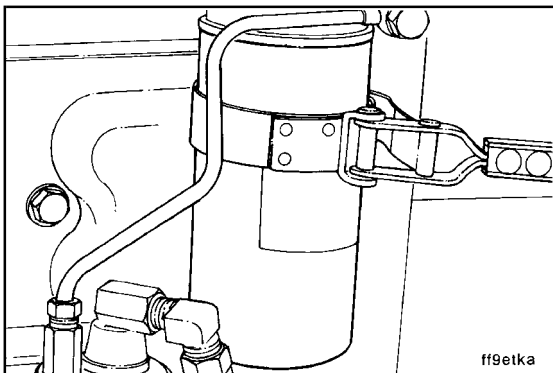

Normal pressure drop across the filter is 21 kPa [3 psi], maximum.

The pressure drop will increase as the filter removes contamination from the fuel. Therefore, a worn transfer pump will have reduced capacity to force fuel through a dirty filter. This can cause low engine power.

**NOTE:** Frequent filter replacement to get full power from the engine can indicate a worn transfer pump.

**Fuel Transfer Pump (Piston Style)**

The B Series engine uses three different piston-style fuel transfer pumps. All three deliver different flow volumes.

**B3.9 and B5.9 Series Engines**  
**Section 5 - Fuel System - Group 05**

Piston-style fuel transfer pump, Part No. 3918076, is offered as an option on B Series engines equipped with distributor-type fuel injection pumps.

**NOTE:** Part No. 3918076 and 3918000 are identical in appearance. The pumping spring free length can be measured to identify the fuel transfer pump.

Fuel transfer pump, Part No. 3918000, spring free length is 53.5 mm [2-7/64 in].

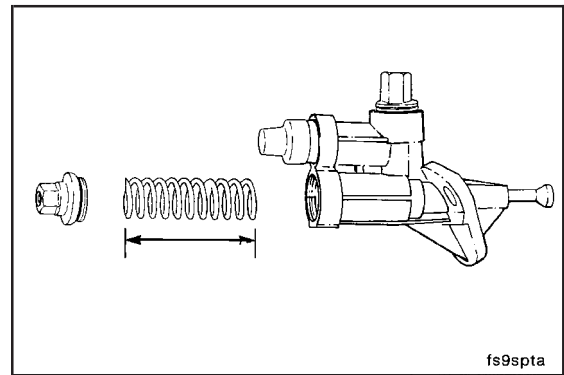

Piston-style fuel transfer pump, Part No. 39108000, comes standard on the 300-hp marine B Series engine.

**NOTE:** Part No. 3918076 and 3918000 are identical in appearance. The pumping spring free length can be measured to identify the fuel transfer pump.

Fuel transfer pump, Part No. 3918000, spring free length is 58 mm [2-9/32 in].

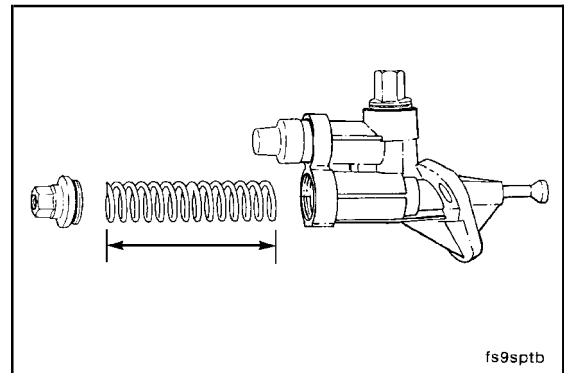

Piston-style fuel transfer pump, Part No. 3921550, comes standard on the '91B Series engines equipped with the Bosch® P7100 in-line fuel injection pumps.

Piston-style fuel transfer pump, Part No. 3925709, comes standard on the '94B Series engines equipped with the Bosch® P7100 in-line fuel injection pumps.

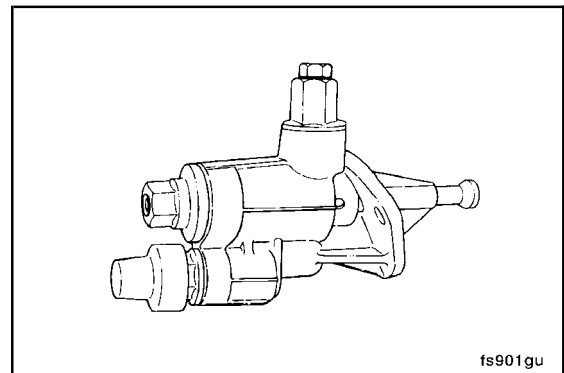

The piston-style fuel transfer pump is mechanically driven by a plunger running against a special lobe on the camshaft. The fuel transfer pump contains a pumping piston and check valves to control the flow of fuel, and bleed back during engine shutdown.

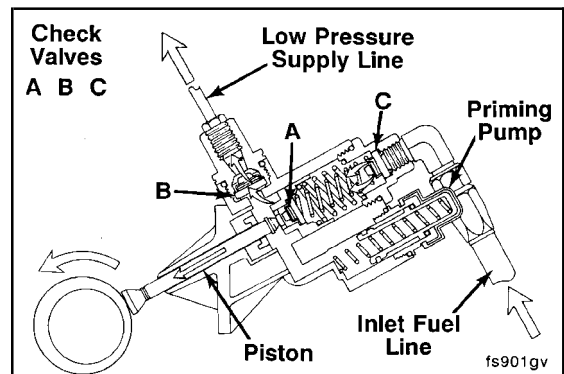

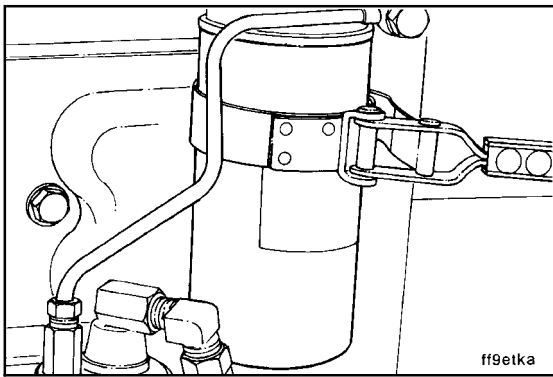

Normal pressure drop across the fuel filter is 35 kPa [5 psi], maximum.

The pressure drop will increase as the fuel filter removes contamination from the fuel. Therefore, a worn fuel transfer pump will have reduced capacity to force fuel through a dirty fuel filter. This can cause low engine power.

**NOTE:** Frequent fuel filter replacement to get full power from the engine can indicate a worn transfer pump.

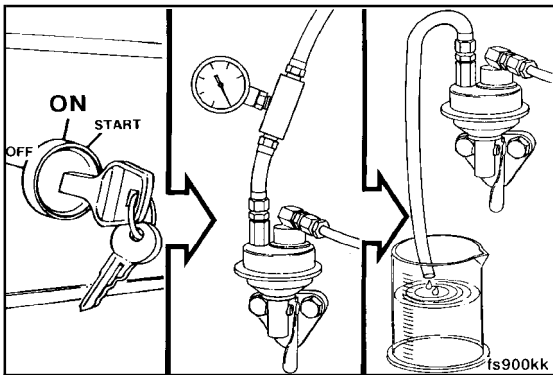

The output of the fuel transfer pump can be checked two ways:

Test 1: Measure the output pressure using an in-line pressure gauge installed between the filter head and the fuel injection pump.

Test 2: Measure the flow volume.

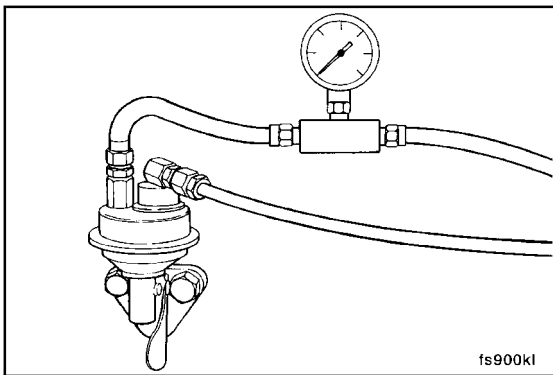

**Test 1: Output Pressure Test (Diaphragm Style)**

Start the engine, and measure the output pressure of the fuel transfer pump using an in-line pressure gauge.

Minimum pressure at rated speed is 21 kPa [3 psi].

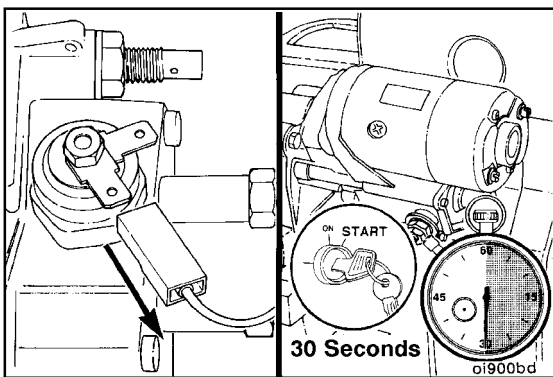

**Test 2: Flow Volume Test (Diaphragm Style)**



To prevent the engine from starting, disconnect the fuel shutdown wiring. Residual fuel in the injection pump can cause the engine to start.



Do not crank the starter for more than 30 seconds at a time. Doing so can result in starter damage.

**Tachometer, Part No. 3377462**

Disconnect the fuel shutdown solenoid wire, and measure the engine cranking speed with a handheld tachometer Cummins Part No. 3377462.

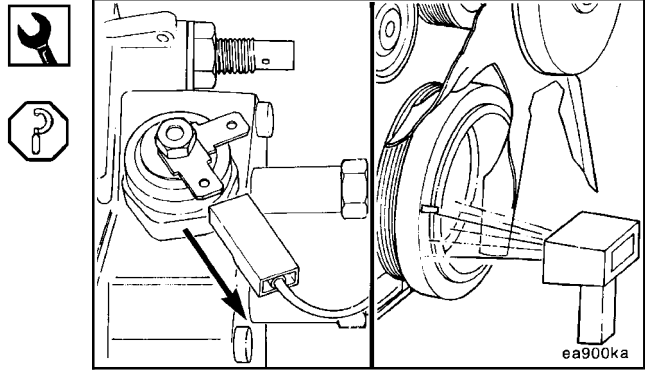

**⚠ CAUTION ⚠**

Leave the shutdown solenoid disconnected for the following check.

Disconnect the output pressure line from the fuel transfer pump, and run it into a container.

Measure the fuel transfer pump flow volume while cranking the engine with the starter for 30 seconds.

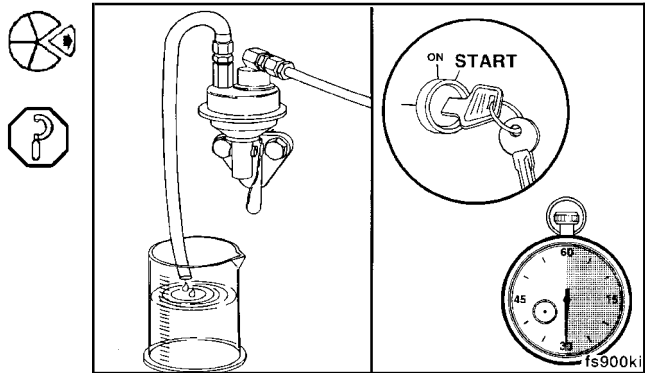

Use the chart in the illustration to find the correct flow volume specification for the diaphragm fuel transfer pump.

- Draw a straight vertical line above the measured cranking rpm
- Draw a straight horizontal line from the measured flow volume to the engine cranking rpm vertical line to find the intersection point
- Any intersection point above the required flow line indicates an acceptable flow
- Any intersection point below the required flow line indicates unacceptable flow and a defective pump or too much line restriction.

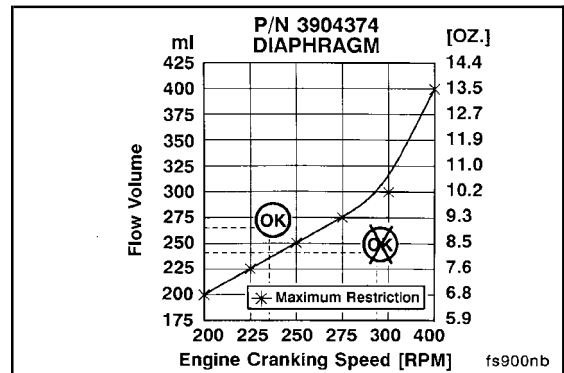

For example, if cranking speed of the engine is 230 rpm at a flow volume of 260 ml [8.8 oz], this would indicate a good pump.

For example, if cranking speed of the engine is 290 rpm at a flow volume of 240 ml [8.1 oz], this would indicate a bad pump.

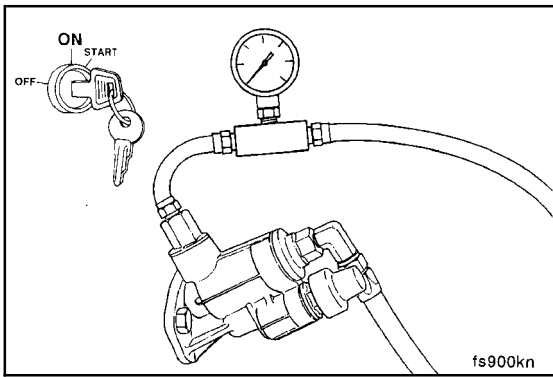

**Test 1: Output Pressure Test (Piston Style)**

Operate the engine, and measure the output pressure of the fuel transfer pump using an in-line pressure gauge at the inlet to the injection pump.

Minimum pressure at rated speed is 172 kPa [25 psi].

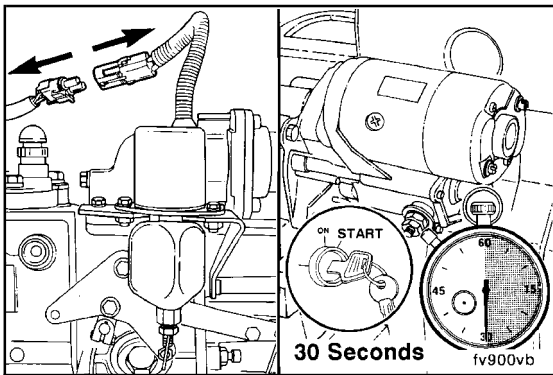

**Test 2: Flow Volume Test (Piston Style)**



To prevent the engine from starting, disconnect the fuel shutdown wiring. Residual fuel in the injection pump can cause the engine to start.



Do not crank the starter for more than 30 seconds at a time. Doing so can result in starter damage. Also, high voltage during cranking can damage the shutdown solenoid.

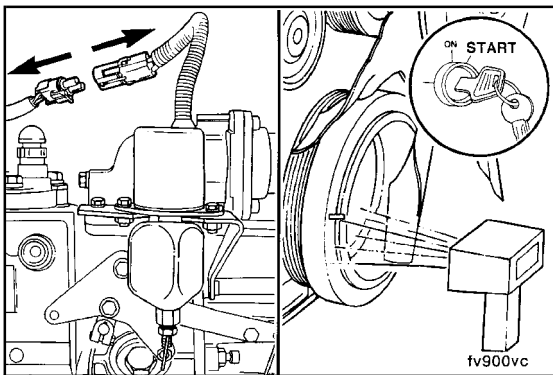

**Tachometer, Part No. 3377462**

Disconnect the fuel shutdown solenoid wire.



Measure the engine cranking speed with a handheld tachometer (Cummins Part No. 3377462).

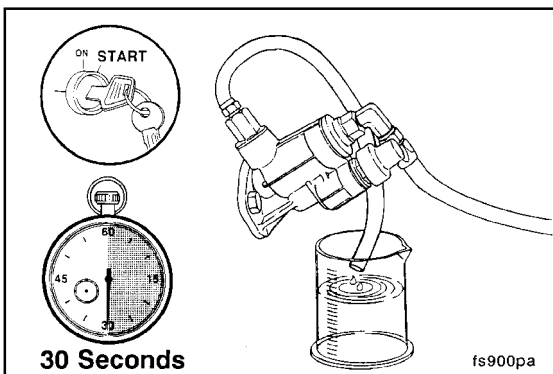

Leave the shutdown solenoid disconnected for the following check:



Disconnect the output pressure line from the transfer pump, and run it into a container.



Crank the engine for 30 seconds, and measure the fuel transfer pump flow volume.

Refer to following chart(s).

AC Rochester

Fuel Transfer Pump Flow Volume

Use the chart in the illustration to find the correct flow volume specification for Cummins Part No. 3918076, fuel transfer pump.

- Draw a straight vertical line above the measured cranking rpm
- Draw a straight horizontal line from the measured flow volume to the engine cranking rpm vertical line to find the intersection point
- Any intersection point above the required flow line indicates an acceptable flow
- Any intersection point below the required flow line indicates unacceptable flow and a defective pump or too much line restriction.

For example, if cranking speed of the engine is 240 rpm at a flow volume of 280 ml [9.5 oz], this would indicate a good pump.

For example, if cranking speed of the engine is 280 rpm at a flow volume of 260 ml [8.8 oz], this would indicate a bad pump.

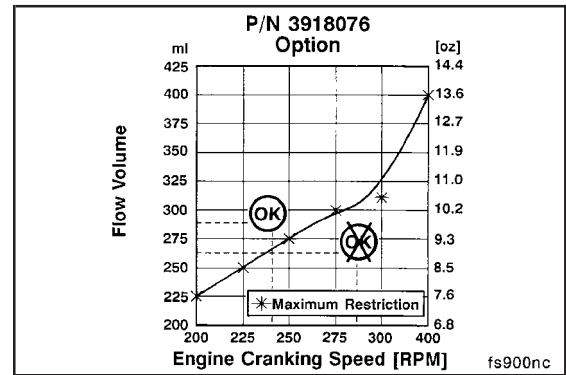

Use the chart in the illustration to find the correct flow volume specification for Cummins Part No. 3918000, fuel transfer pump, used on the 300-hp B Series marine engine.

- Draw a straight vertical line above the measured cranking rpm
- Draw a straight horizontal line from the measured flow volume to the engine cranking rpm vertical line to find the intersection point
- Any intersection point above the required flow line indicates an acceptable flow
- Any intersection point below the required flow line indicates unacceptable flow and a defective pump or too much line restriction.

For example, if cranking speed of the engine is 240 rpm at a flow volume of 260 ml [8.8 oz], this would indicate a good pump.

For example, if cranking speed of the engine is 280 rpm at a flow volume of 235 ml [7.9 oz], this would indicate a bad pump.

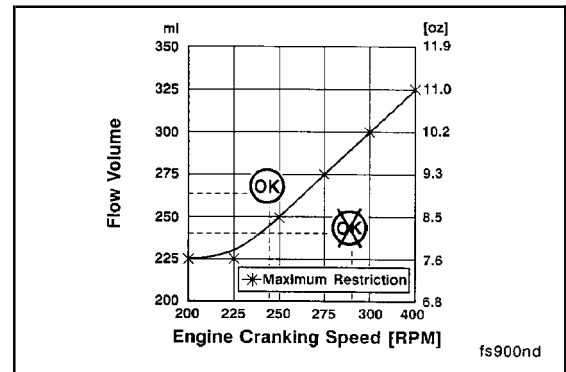

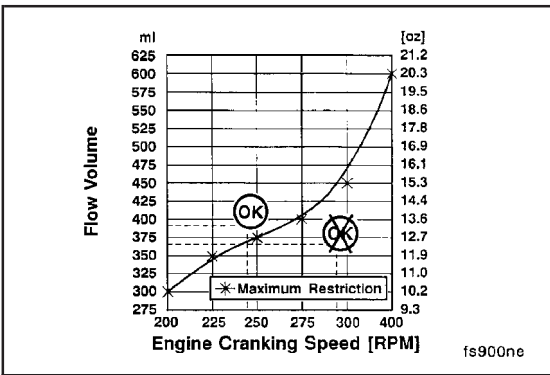

Use the chart in the illustration to find the correct flow volume specification for Cummins Part No. 3917334, fuel transfer pump, used with the Bosch® P7100 in-line injection pump.

- Draw a straight vertical line above the measured cranking rpm
- Draw a straight horizontal line from the measured flow volume to the engine cranking rpm vertical line to find the intersection point
- Any intersection point above the required flow line indicates an acceptable flow
- Any intersection point below the required flow line indicates unacceptable flow and a defective pump or too much line restriction.

For example, if cranking speed of the engine is 240 rpm at a flow volume of 390 ml [13.2 oz], this would indicate a good pump.

For example, if cranking speed of the engine is 290 rpm at a flow volume of 360 ml [12.2 oz], this would indicate a bad pump.

**Fuel Transfer Pump Flow Volume (Federal Mogul-Carter)**

Use the chart in the illustration to find the correct flow volume specification for Cummins Part No. 3930349, 3932228, 3933256, 3936320 fuel transfer pumps, and superseding Cummins part numbers.

- Draw a straight vertical line above the measured cranking rpm
- Draw a straight horizontal line from the measured flow volume to the engine cranking rpm vertical line to find the intersection point
- Any intersection point above the required flow line indicates an acceptable flow
- Any intersection point below the required flow line indicates unacceptable flow and a defective pump or too much line restriction.
- The maximum inlet restriction to the lift pump is 100 mm Hg [4 in Hg].

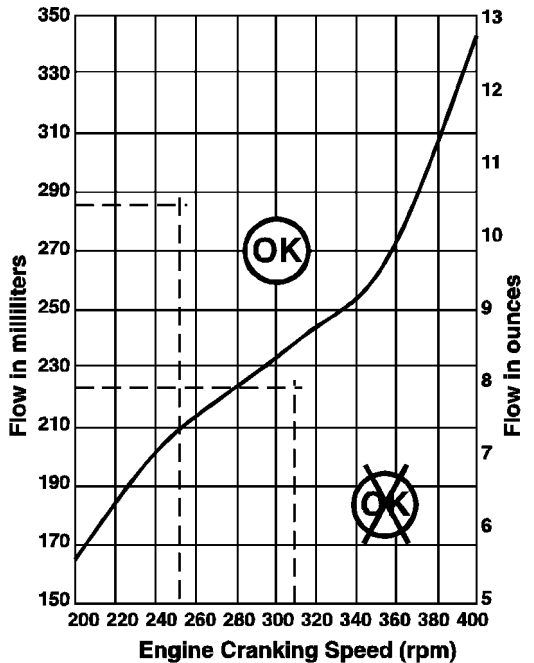



**B3.9 and B5.9 Series Engines  
Section 5 - Fuel System - Group 05**

Use the chart in the illustration to find the correct flow volume specification for Cummins Part No. 3930134, 3930135, 3932224, 3932225, 3933252, 3933253, 3936316, 3936317 fuel transfer pumps, and superseding Cummins part numbers.

- Draw a straight vertical line above the measured cranking rpm
- Draw a straight horizontal line from the measured flow volume to the engine cranking rpm vertical line to find the intersection point
- Any intersection point above the required flow line indicates an acceptable flow
- Any intersection point below the required flow line indicates unacceptable flow and a defective pump or too much line restriction.
- The maximum inlet restriction to the lift pump is 100 mm Hg [4 in Hg].

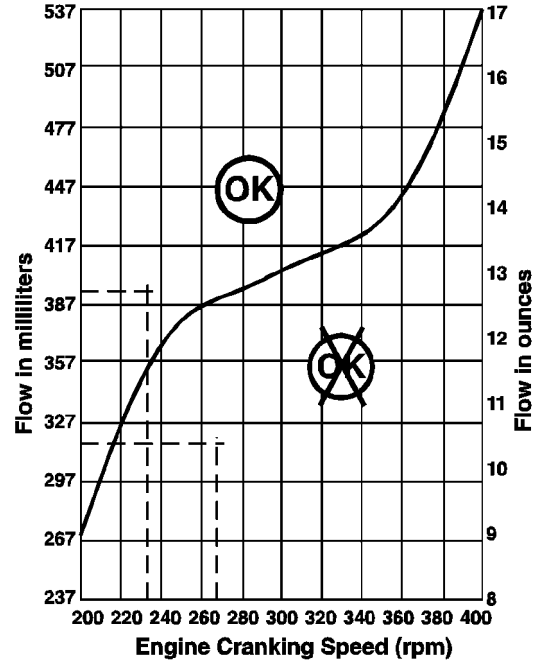

06900035

Use the chart in the illustration to find the correct flow volume specification for Cummins Part No. 3930201, 3930202, 3932226, 3932227, 3933254, 3933255, 3936318, 3936319 fuel transfer pumps, and superseding Cummins part numbers.

- Draw a straight vertical line above the measured cranking rpm
- Draw a straight horizontal line from the measured flow volume to the engine cranking rpm vertical line to find the intersection point
- Any intersection point above the required flow line indicates an acceptable flow
- Any intersection point below the required flow line indicates unacceptable flow and a defective pump or too much line restriction.
- The maximum inlet restriction to the lift pump is 100 mm Hg [4 in Hg].

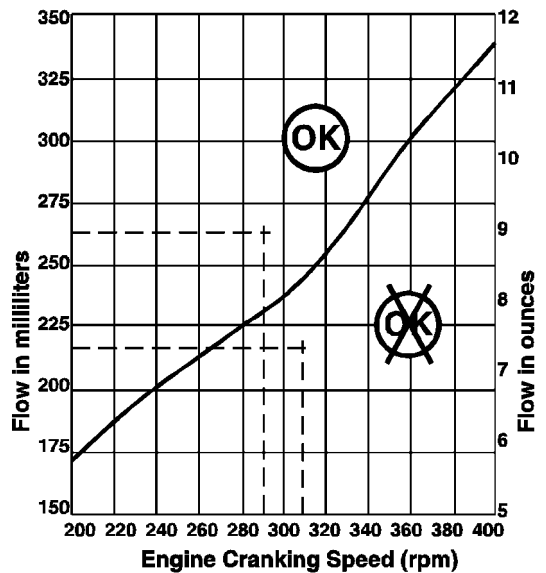

06900036

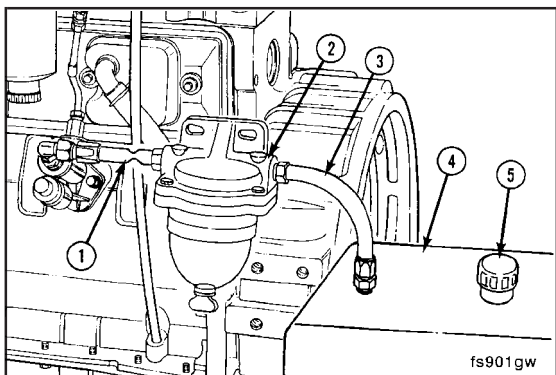

If the fuel transfer pump delivers the required volume of fuel from a temporary supply, check for restrictions or suction leaks in the fuel circuit to the fuel transfer pump:

1. Supply line
2. Prefilter
3. Supply line
4. Supply tank
5. Tank vent.

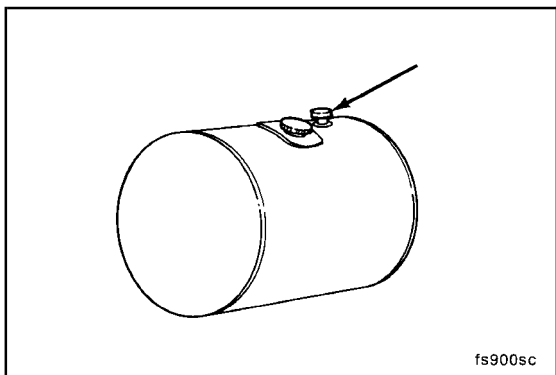

Check for a plugged supply tank vent first.

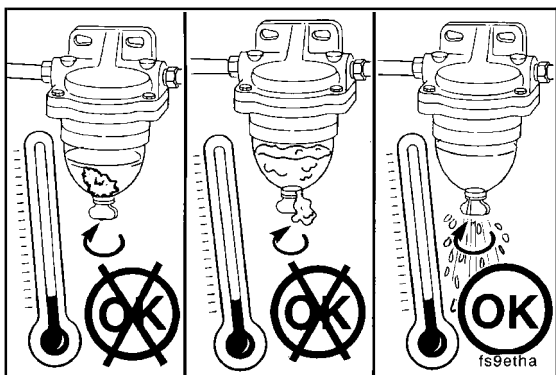

Replace or clean the prefilter.  
In cold weather check for gelled fuel blocking the prefilter.

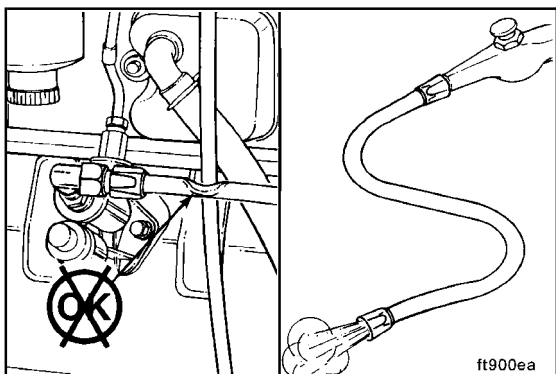

Check for kinks that can restrict the fuel supply lines.  
Remove and blow out the fuel supply lines.

**Install (005-045-026)**

**▲ CAUTION ▲**

Alternately tighten the mounting capscrews. As the capscrews are tightened, the fuel transfer pump plunger is pushed into the pump. Failure to tighten the capscrews in an even manner can result in the plunger being bent or broken, causing sticking and failure.

10 mm

**Diaphragm Style and Piston Style**

Install the pump.

**Torque Value:** 24 N•m [18 ft-lb]

The 5-mm [0.20-in] spacer (1), Cummins Part No. 3914284, **must** be installed along with a gasket, Cummins Part No. 3931348, on each side of the spacer.

**NOTE:** For some applications, a bracket used for supporting other options will replace the 5-mm spacer.

14 mm, 17 mm, 20 mm

Install the fuel line to the fuel transfer pump and fuel filter head. Use two wrenches to tighten the connection to the pump.

**Torque Value:** 24 N•m [18 ft-lb]

Vent the low-pressure fuel lines. Refer to Procedure 006-024.

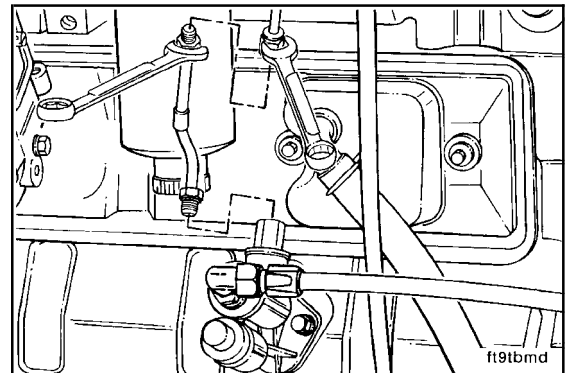
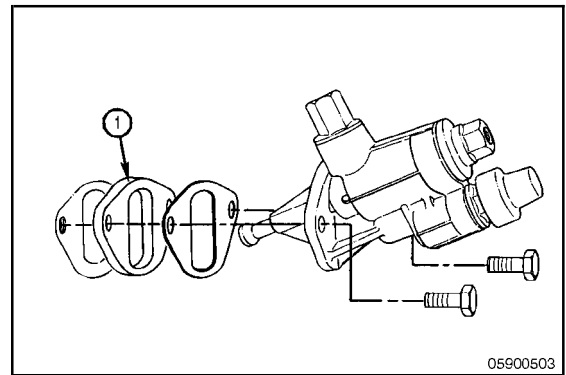

**Vent (005-045-032)**

10 mm

Open the banjo bleed screw to bleed the low-pressure fuel line.

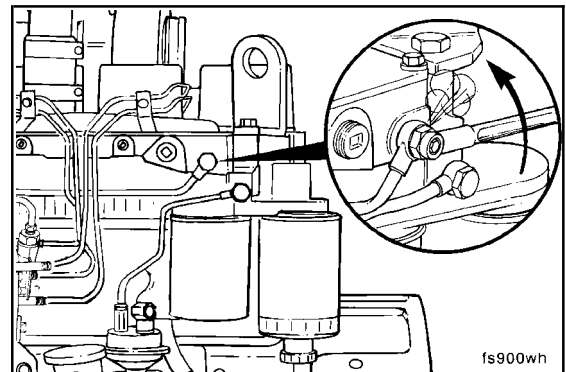

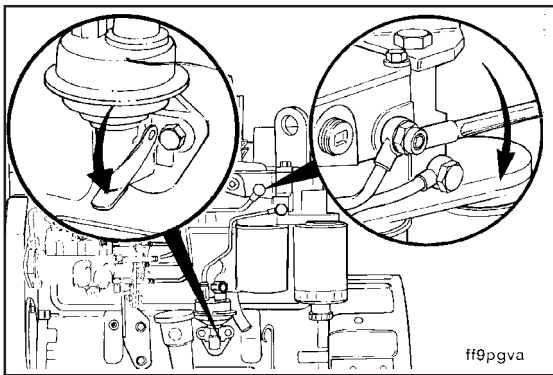

10 mm

Operate the hand lever until the fuel flowing from the fitting is free of air.



Tighten the bleed screw.

Torque Value: 9 N•m [80 in-lb]

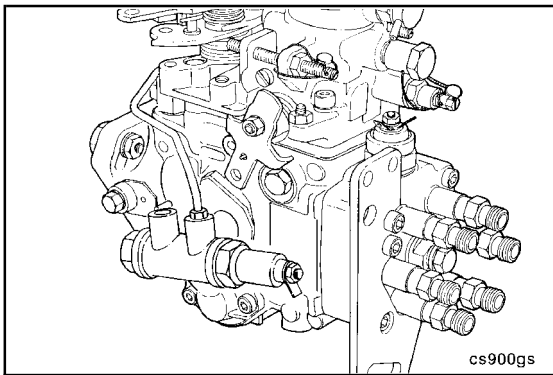

## Cold Start Timing Advance System (KSB) Remote (005-046)

### General Information

#### Cold Start Timing Advance System (KSB) - Wax Motor Style

The wax motor-style KSB is used on pre-1991 B Series automotive engine ratings using the Bosch® VE fuel pump.

**NOTE:** The electrical solenoid-style KSB is used on 1991 model and newer B Series automotive engine ratings using the Bosch® VE fuel injection pump. See Procedure 005-070, Cold Start Timing Advance System (KSB) — Electrical Solenoid Style, for additional information.

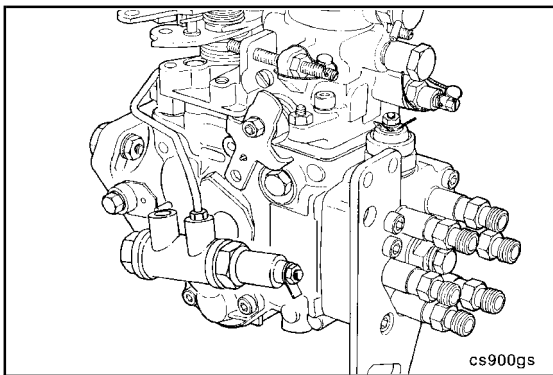

#### Wax Motor Style KSB

**NOTE:** Temperature switch is located in the coolant jacket.

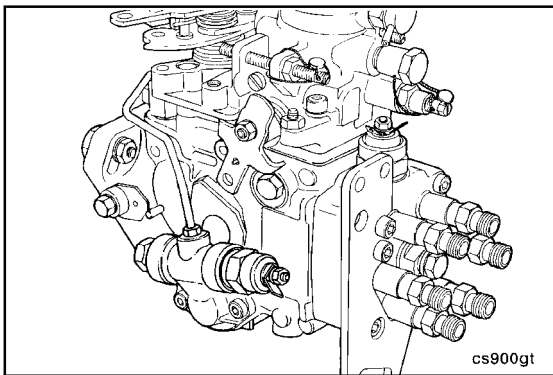

#### Electrical Solenoid-Style KSB

**NOTE:** Temperature switch is located in the intake manifold.

**KSB Hardware Definition**

There are currently two versions of pump-mounted wax motor-style KSBs released in the Cummins system and one remote-mounted version. The remote mounted option is necessary in applications where the pump-mounted KSB causes interference (i.e., with the air compressor).

**Remote Mounted KSB**

The remote-mounted KSB is used on B Series automotive engines that have an air compressor.

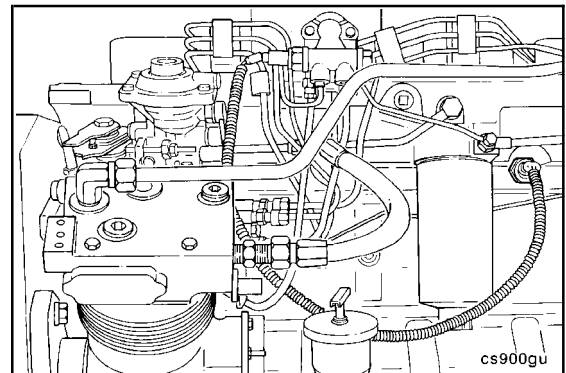

**⚠ CAUTION ⚠**

Most pumps will have a shim between the KSB and the timing piston. This shim must be reassembled between the cover plate and the timing piston. If this shim sticks to the KSB and is installed with the remote-mounting hardware, it will block the regulating valve drain path and damage the pump. This damage is usually evidenced by a fuel leak.

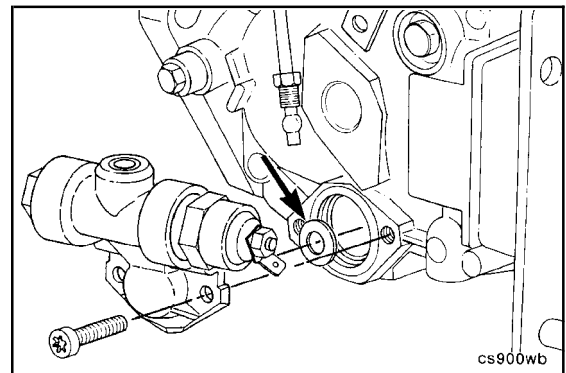

The four-cylinder engine using remote mounting requires the temperature switch to be installed in the cylinder head as illustrated.

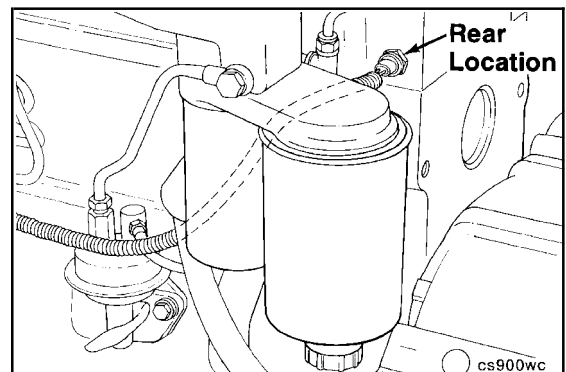

**Cold Start Timing Advance System (KSB) - Electrical Solenoid Style**

The electrical solenoid-style KSB is used on 1991 model and newer B Series automotive engine ratings using the Bosch® VE fuel pump.

**NOTE:** The wax motor-style KSB is used on pre-1991 B Series automotive engine ratings using the Bosch® VE fuel pump. See Procedure 005-046, Cold Start Timing Advance System (KSB) - Wax Motor Style, for additional information.

**Wax Motor-Style KSB**

**NOTE:** The temperature switch is located in the coolant jacket.

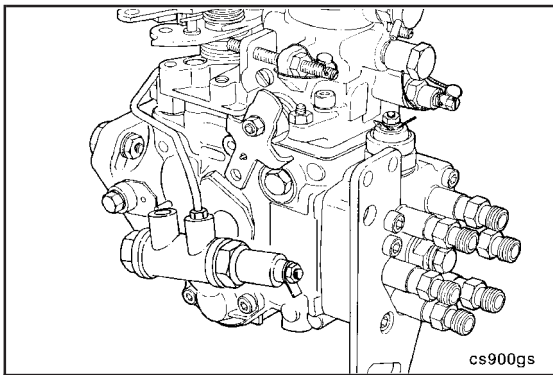

**Electrical Solenoid-Style KSB**

**NOTE:** Temperature switch is located in intake manifold.

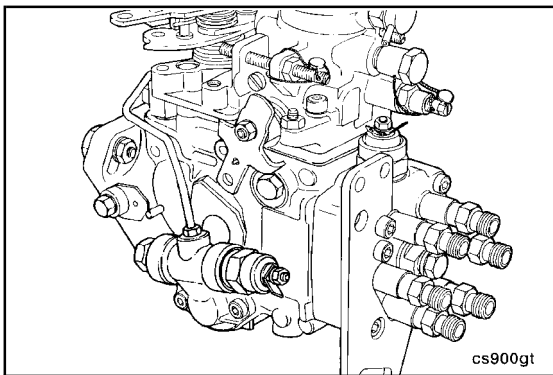

Two types of electrical solenoid-style KSB valves are available.

The first type is the pump-mounted KSB, as shown.

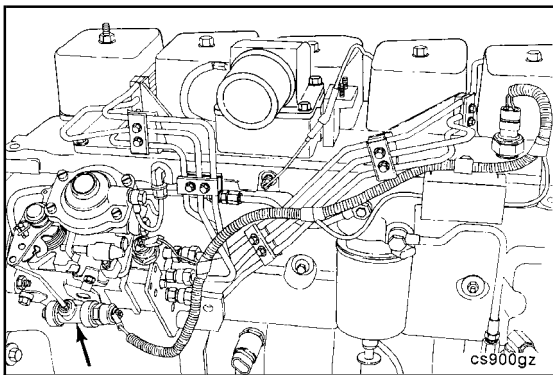

The second type is the remote-mounted KSB, as shown.  
The remote-mounted KSB is used on B Series automotive engines that have an air compressor.

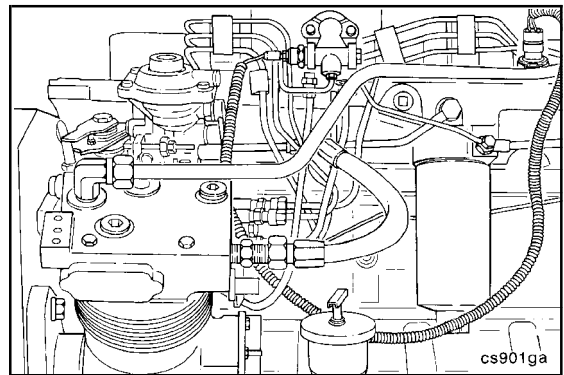

**⚠ CAUTION ⚠**

Most pumps will have a shim between the KSB and the timing piston. This shim must be reassembled between the cover plate and the timing piston. If this shim sticks to the KSB and is installed with the remote-mounting hardware, it will block the regulating valve drain path and damage the pump. This damage is usually evidenced by a fuel leak.

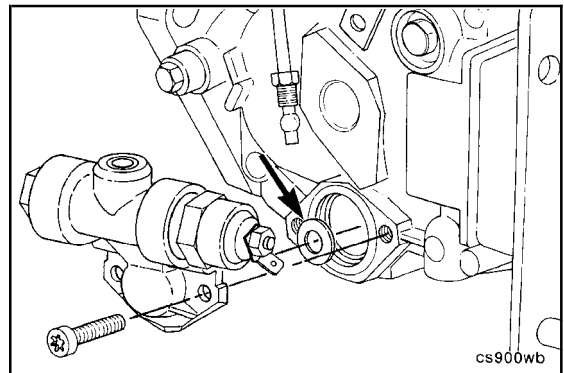

Both the four-and-six cylinder have the temperature switch mounted in the intake manifold, as shown.

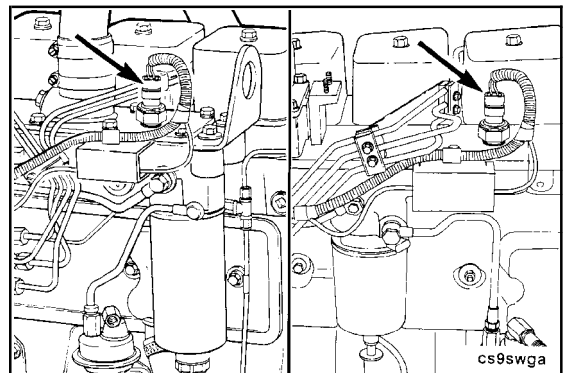

**Disassemble (005-046-003)**

22 mm

Loosen and remove the KSB electrical element from the KSB housing.

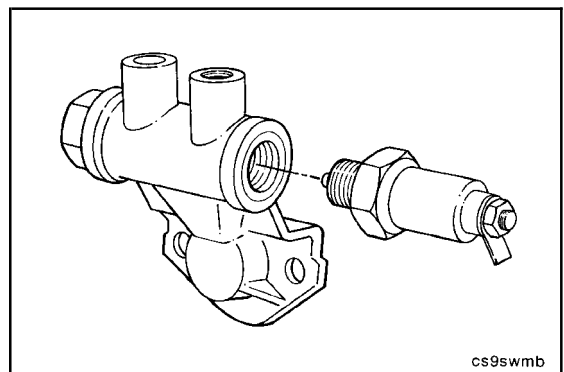

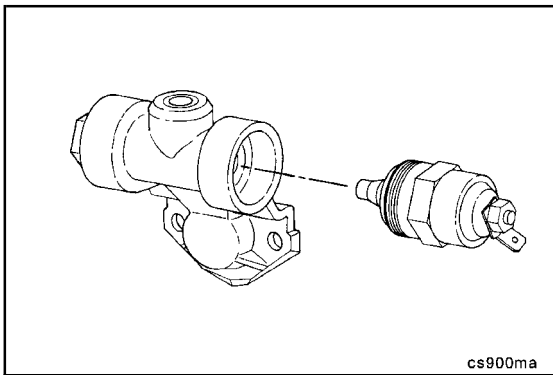

24 mm

Remove the KSB electrical solenoid from the KSB housing.

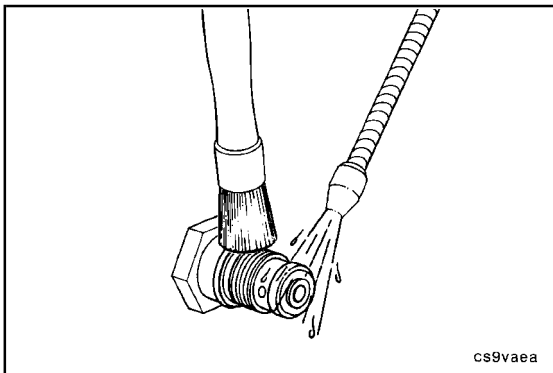

Clean (005-046-006)

**▲ WARNING ▲**

When using solvents, acids, or alkaline materials for cleaning, follow the manufacturer's recommendations for use. Wear goggles and protective clothing to avoid personal injury.

**▲ WARNING ▲**

Wear appropriate eye and face protection when using compressed air. Flying debris and dirt can cause bodily injury.

Thoroughly flush the pressure relief valve with cleaning solution.

Dry with compressed air.

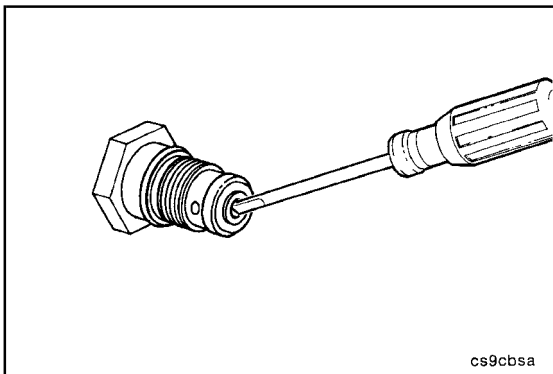

Use a very small screwdriver to be sure the check ball is **not** sticking.

**NOTE:** A sticking or malfunctioning pressure relief valve will result in either white smoke or a ruptured fuel pump housing.

Replace the pressure relief valve assembly, if necessary.

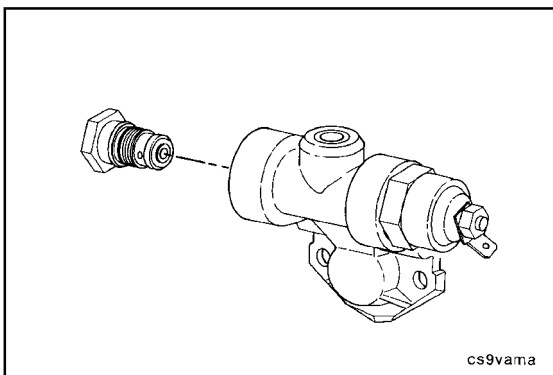

17 mm

Install the original pressure relief valve or a replacement into the KSB housing.



**Torque Value:** 13 N•m [115 in-lb]





**Test (005-046-012)**

Apply 12 VDC to the electrical terminal and a ground strap to the hexagonal portion of the element. Check for extensional movement of the plunger. If the plunger does **not** move after approximately 1 minute, check to make sure the element has been correctly connected to ground. If all connections are correct and the plunger does **not** move, the element is defective and **must** be replaced.

**NOTE:** The amount of plunger movement will vary depending upon the ambient temperature.

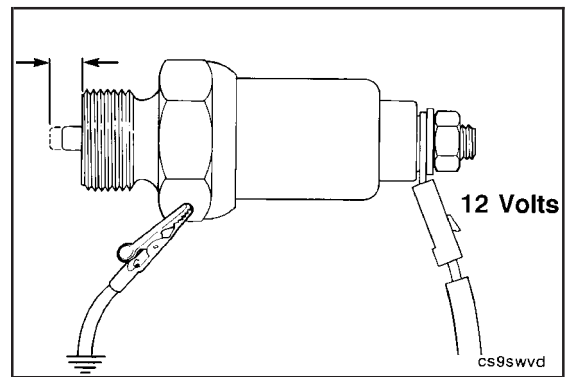

Apply 12 VDC to the electrical terminal, and ground the hexagonal portion of the element. The magnetic coil of the solenoid **must** push the plunger outward.

If the plunger does **not** push outward when voltage is applied, the solenoid is defective and **must** be replaced.

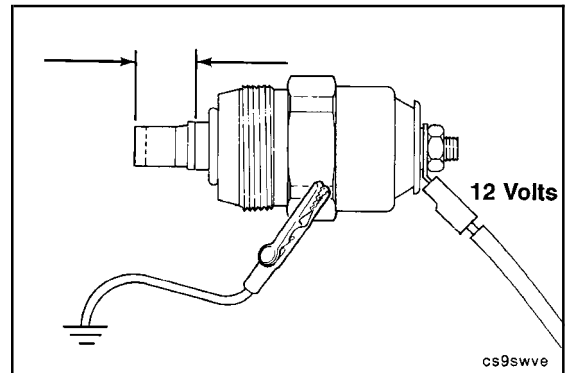

**Assemble (005-046-025)**

**22 mm**

Install the original element or a replacement into the KSB housing.

**Torque Value:** 22 N•m [16 ft-lb]

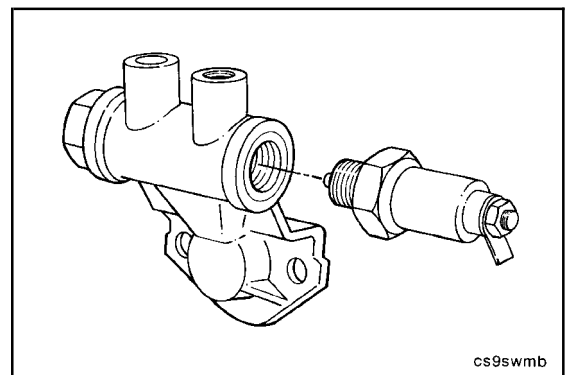

**24 mm**

Install the original solenoid or a replacement into the KSB housing.

**Torque Value:** 22 N•m [16 ft-lb]

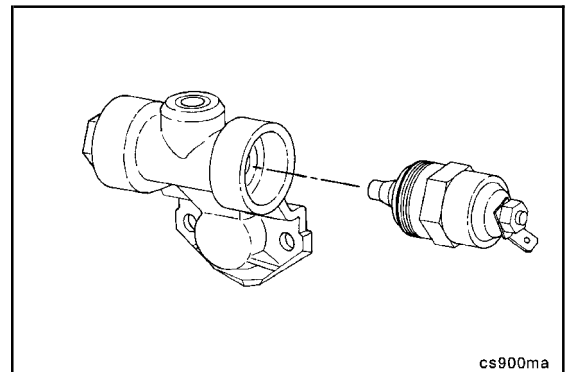

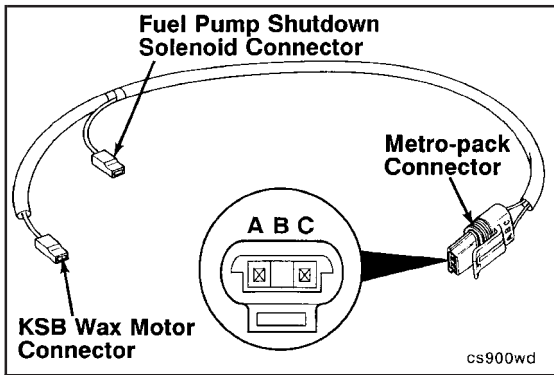

**Resistance Check (005-046-038)**

The wiring harness used on the wax motor-style KSB can be inspected using a multimeter.

**NOTE:** Pin C of the metro-pack connector is blank on the wax motor style KSB wiring harness.

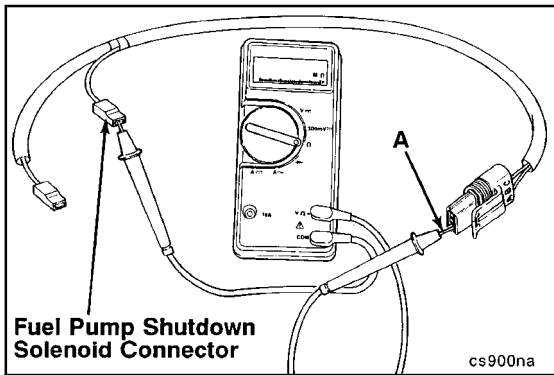

Use a multimeter to perform a continuity check between port A of the metro-pack connector and the female spade connector at the fuel pump shutdown solenoid connector.

Repair the wire if there is an open circuit.

Ohms Resistance - Less than 10.

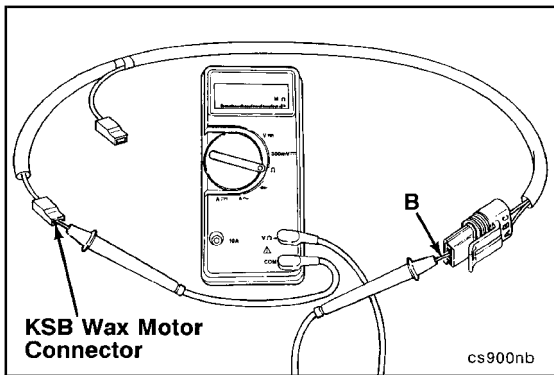

Use a multimeter to perform a continuity check between port B of the metro-pack connector and the female spade connector at the KSB wax motor connector.

Repair the wire if there is an open circuit.

Ohms Resistance - Less than 10.

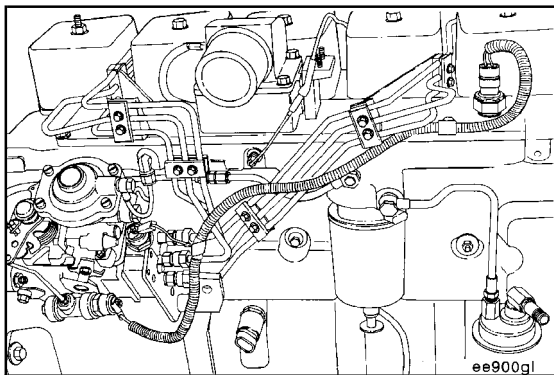

Engines with CPL 1579 do **not** have a resistor in the harness.

Engines with CPL 1351 **must** be wired with the resistor in the harness.

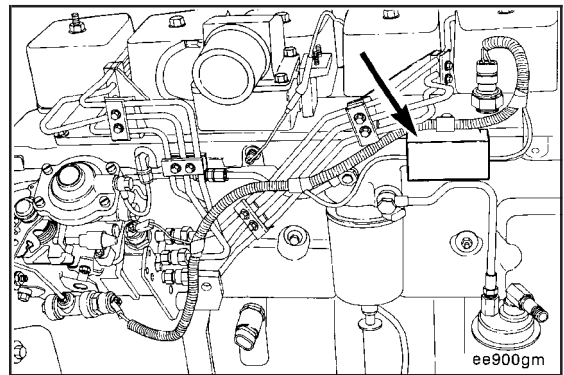

The wiring harness used on the electric solenoid-style KSB can be inspected using a multimeter.



**NOTE:** Pin B of the metro-pack connector is blank on the electric solenoid style KSB wiring harness.

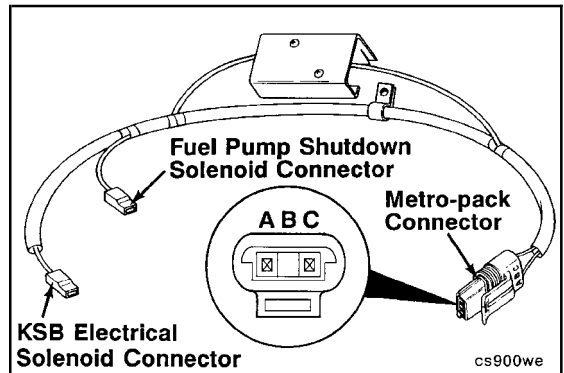

The electric solenoid-style KSB wiring harness contains a 3-ohm resistor in the wire leading from port C of the metro-pack connector to the KSB electrical solenoid connector.

The 3-ohm resistor is mounted to a bracket that is utilized as a heat sink to absorb heat that is generated by the resistor.

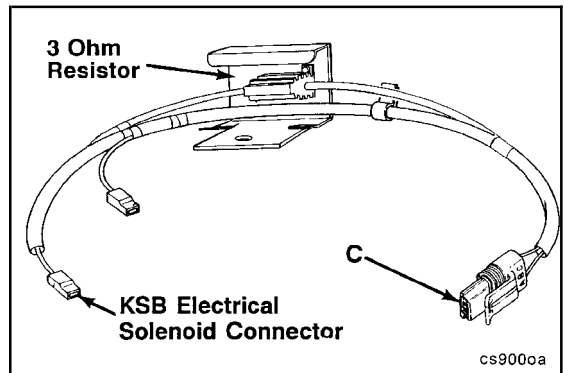

Use a multimeter to perform a continuity check between port C of the metro-pack connector and the KSB electrical solenoid connector.



Repair the wire if there is an open circuit.

(Spec = Less than 10 ohms).

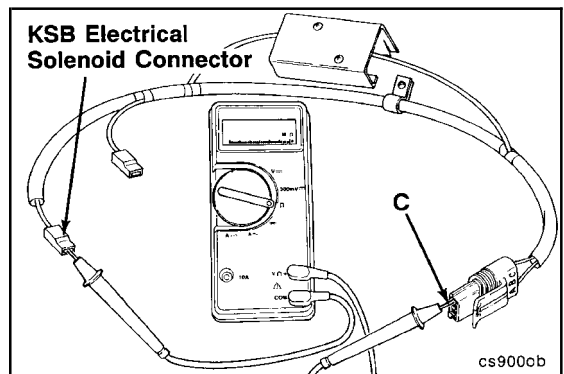

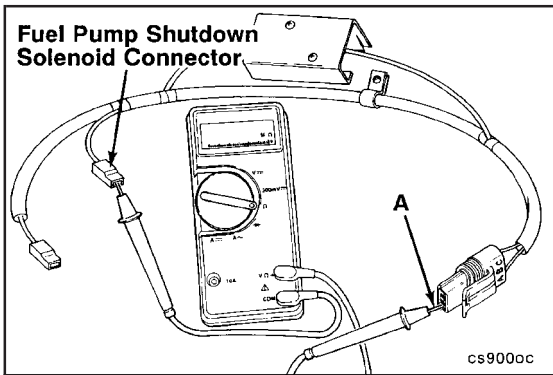

Use a multimeter to perform a continuity check between port A of the metro-pack connector and the fuel pump shutdown solenoid connector.

Repair the wire if there is an open circuit.

(Spec = Less than 10 ohms).

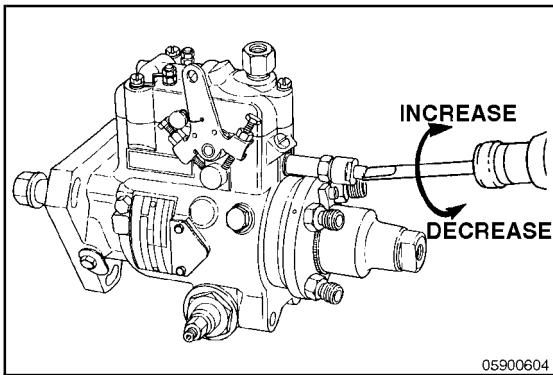

## Speed Droop Governor (005-058)

### Adjust (005-058-029)

#### Stanadyne DB4 (Generator Application) Speed Droop Governor

Governor regulation of 3 percent to 5 percent can be attained with the speed droop governor. Precise control of governor regulation is done by decreasing or increasing the effective length of the governor control spring; this also decreases or increases the spring control spring rate. The governor control spring is threaded into an adjusting cap assembly and is referred to as the control rod assembly. By turning the adjusting cap in the **clockwise** direction, as viewed from the fuel transfer pump end, the control rod spring shortens and becomes less sensitive, thereby increasing governor regulation. Turning the adjusting cap in the **counterclockwise** direction increases the control rod spring length and sensitivity, which will decrease governor regulation.

The external speed droop adjustment screw, located at the rear of the fuel injection pump housing, controls the governor sensitivity. The droop screw adjustment varies the governor regulation by changing the effective spring rate. This adjustment will affect both full-load and no-load frequency settings and can require the high-speed stop screw be reset.

Speed droop adjustments **must** be made while the engine is operating. After each adjustment of the droop screw, the engine **must** be shutdown briefly in order to allow the governor spring to unload and the adjusting mechanism to seek its final position in the spring. Turning the screw in shortens the control spring, making it less sensitive and increasing speed droop. Turning the adjusting screw out has the opposite effect. Speed droop is the fuel injection pump's ability to respond to changing engine loads.

**Speed Droop Adjustment**

**NOTE:** If serious surging occurs during the warm-up period, turn the speed droop adjusting screw **clockwise** until the surging stops.

**NOTE:** When the speed droop adjustments are made, it is necessary to adjust the throttle position.

Adjust the governor as follows:

1. Operate the engine until normal operating temperature is obtained 91°C [195°F].
2. When the engine reaches operating temperature, position the throttle to attain rated speed, and apply 100-percent load. Adjust the throttle position as necessary to obtain 100 percent performance.
3. Remove the load, and check for the specified no-load or, in the case of a generator set, note the frequency. If the no-load speed is incorrect, loosen the locking cap, and adjust the speed droop adjusting cap (**clockwise** for increased droop, **counterclockwise** for less droop). If surging occurs when the load is removed, turn the adjusting cap **clockwise** to eliminate the surge. Tighten the locking cap to secure the adjusting screw.
4. Check the 100-percent load and no-load performance again, and make adjustments as necessary.

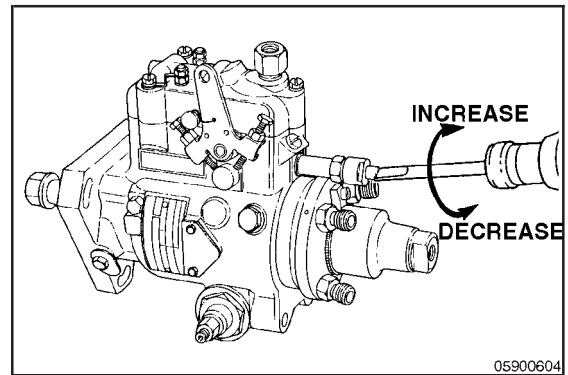

**Fuel Pump Back Leakage Valve (005-059)**

**Preparatory (005-059-000)**

17 mm

Disconnect the high-pressure line. Refer to Procedure 006-051.

**NOTE:** Because the valves are installed 90 degrees to the pump axis, the pump will possibly need to be removed to change the valves close to the cylinder block.

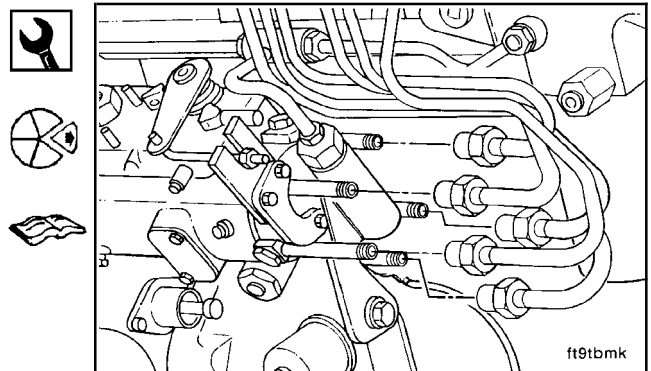

**Remove (005-059-002)**

CAV

16 mm

Remove the valve.

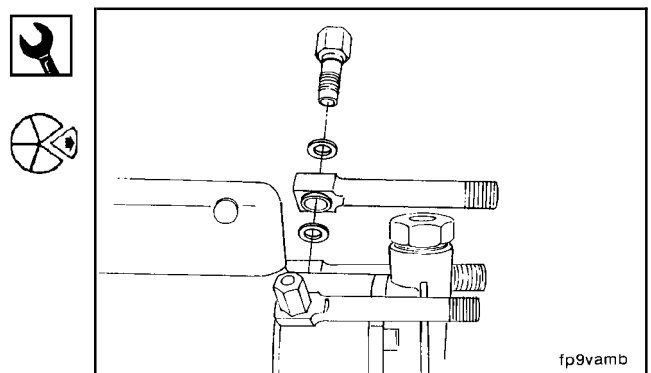

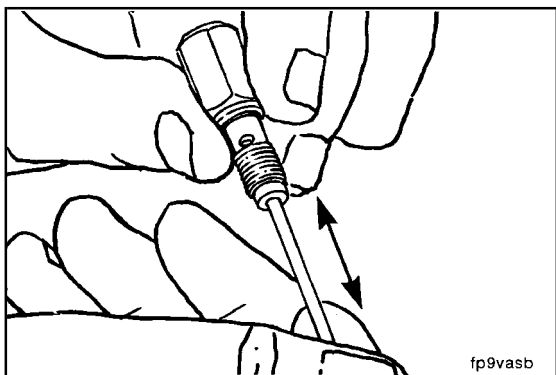

**Inspect for Reuse (005-059-007)**

Inspect the valve to be sure it is **not** stuck.

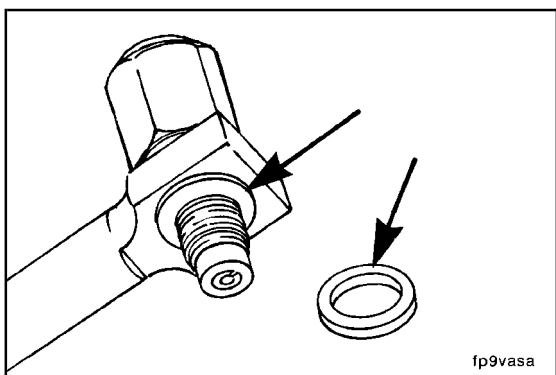

Inspect the sealing surfaces for possible leak paths.

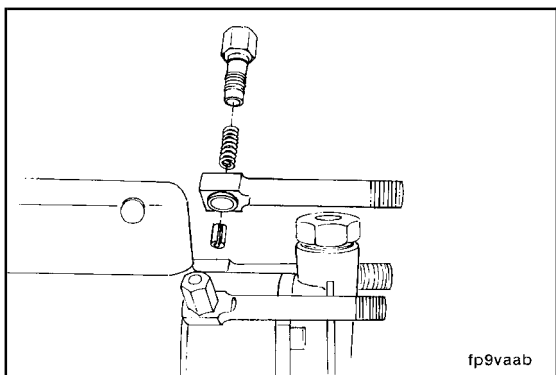

**Install (005-059-026)**

CAV

16 mm



**CAUTION**

The installation torque is very critical. Overtightening can distort the bore in the pump hydraulic head, causing the rotor to seize in the bore. Never tighten the valve with the engine running.



Assemble the back leakage valve and new washers.

Tighten the valve.

**Torque Value:** 30 N•m [22 ft-lb]

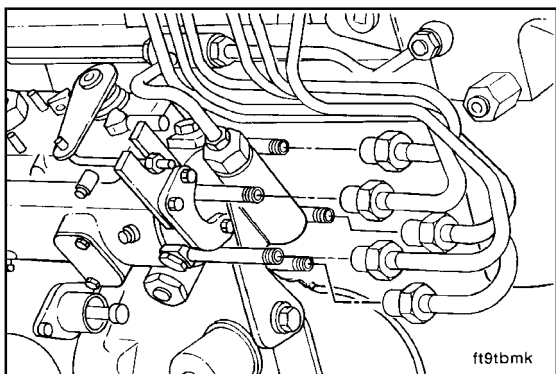

17 mm

Connect the high-pressure line. Refer to Procedure 006-051.



Start the engine, and vent one line at a time until the engine runs smoothly.

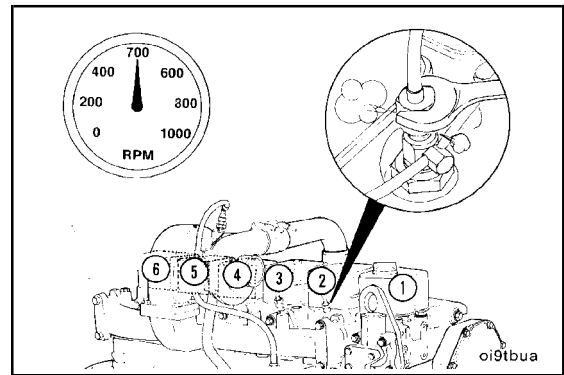

**Fuel Pump Pressure Regulator (005-060)**

**Remove (005-060-002)**

19 mm

Remove the pressure relief valve and copper sealing washer.

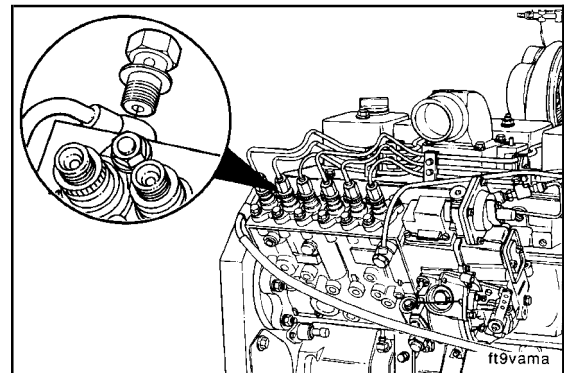

**Clean (005-060-006)**



When using solvents, acids, or alkaline materials for cleaning, follow the manufacturer's recommendations for use. Wear goggles and protective clothing to avoid personal injury.



Wear appropriate eye and face protection when using compressed air. Flying debris and dirt can cause bodily injury.

Thoroughly flush the high-pressure relief valve with a mixture of strong detergent and water or solvent.

Dry with compressed air.



**Inspect for Reuse (005-060-007)**



A sticky check ball can result in engine damage and low power.

Use a small screwdriver to check that the check ball is not sticking in the high-pressure relief valve assembly.

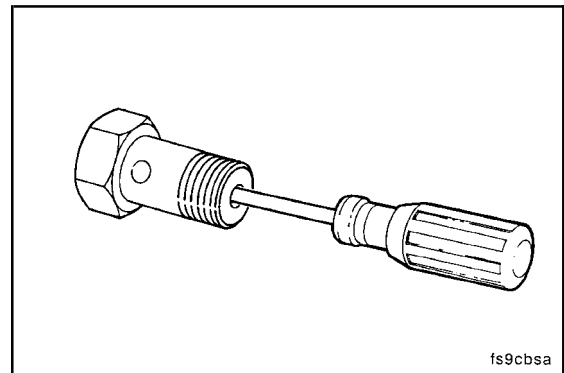

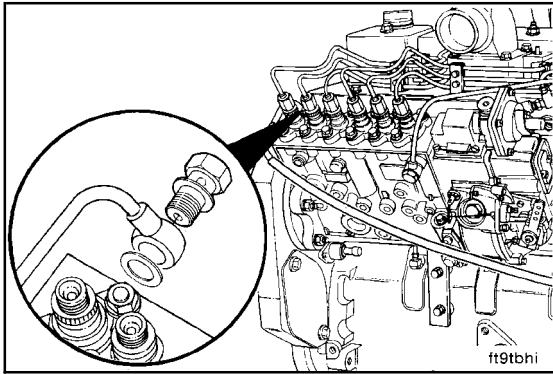

**Install (005-060-026)**

10 mm, 19mm



Install the high-pressure relief valve assembly.

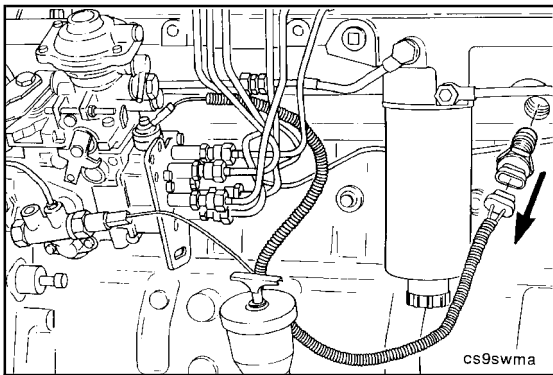

**Cold Start Timing Advance System (KSB) Temperature Switch (005-069)**

**Remove (005-069-002)**

27 mm



Remove the temperature switch.

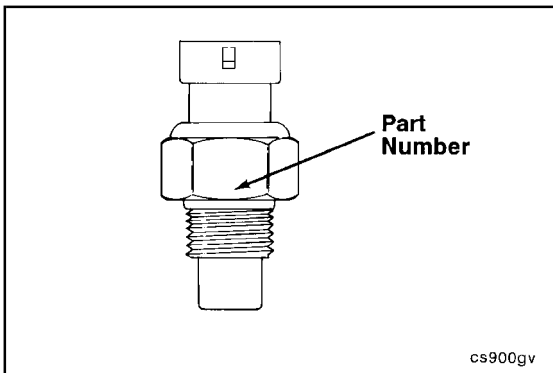

**⚠ CAUTION ⚠**

The switches are not interchangeable. White smoke will be present if the wrong temperature switch is used.

Notes:

1. The wax motor KSB (used on pre-'91 engines) uses a 71°C [160°F] normally open coolant temperature switch, Cummins Part No. 3915945.
2. The electrical solenoid-style KSB (used on '91 models and newer) uses a 32°C [90°F] normally closed intake manifold temperature switch, Cummins Part No. 3921642.

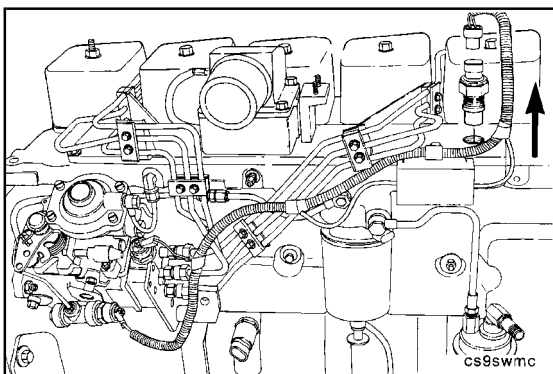

27 mm

Remove the temperature switch from the intake manifold.





**⚠ CAUTION ⚠**

The switches are not interchangeable. White smoke will be present if the wrong temperature switch is used.

Check the part number to be sure the correct temperature switch is used.

**NOTE:** The electrical solenoid-style KSB (used on '91 models and newer) uses a 32°C [90°F] normally closed intake manifold temperature switch, Part No. 3921642.

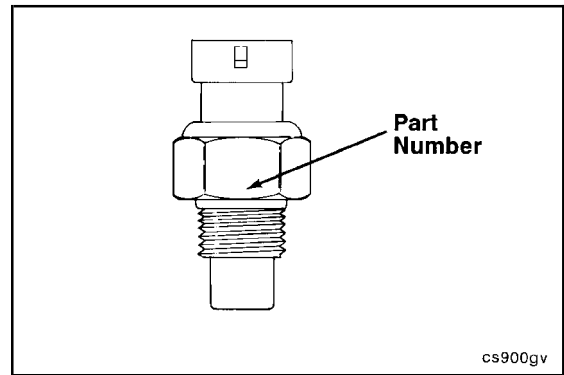

**Test (005-069-012)**

**Wax-Motor Style**

The operation of the temperature switch for the wax motor style KSB can be checked by connecting a multimeter to the switch, placing the switch in water, and then heating the water to 71°C [160°F].

Connect the multimeter to the two pins on the left when viewed with the plastic tang on top.

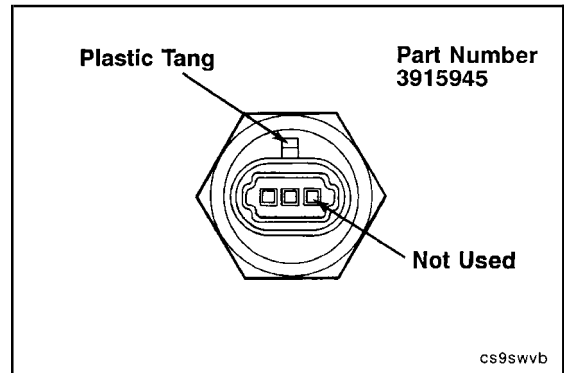

Check the water temperature with a thermometer.

The multimeter should indicate an open circuit below 71°C [160°F] and a closed circuit above 71°C [160°F].

Replace the switch, if necessary.

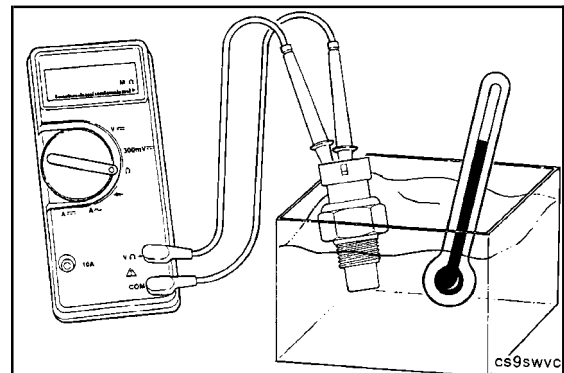

**Electrical Solenoid Style**

Although the electrical solenoid-style KSB uses an intake manifold temperature switch, the operation of the switch can be checked by connecting a multimeter to the switch, placing the switch in ice water, and then heating the water to 32°C [90°F].

Connect the multimeter to the two outside pins of the temperature switch.

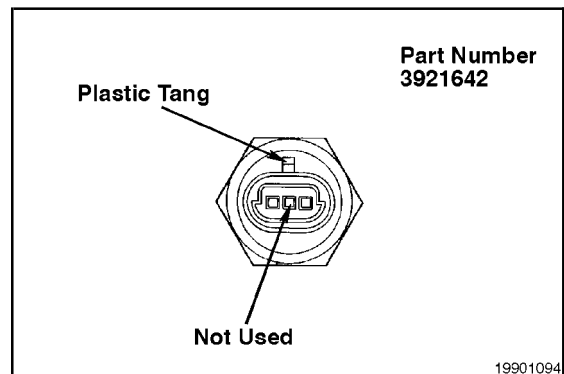

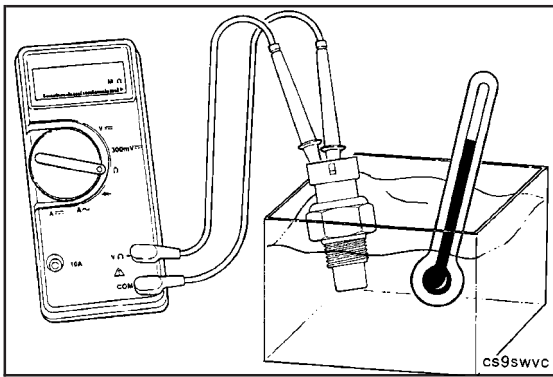

Check the water temperature with a thermometer.

The multimeter should indicate a closed circuit below 32°C [90°F] and an open circuit above 32°C [90°F].



Replace the switch, if necessary.

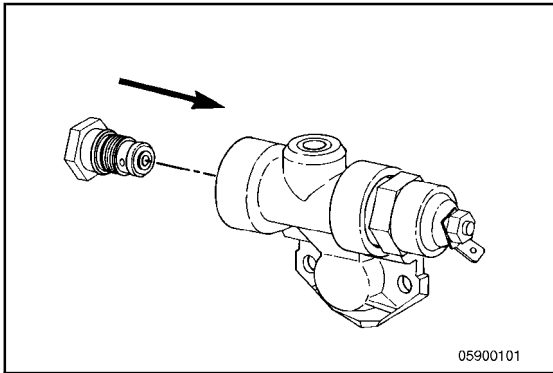

**Install (005-069-026)**

Install the original pressure relief valve or a replacement into the KSB housing.



**Torque Value:** 13 N•m [115 in-lb]

**Cold Start Timing Advance System (KSB) Pump Mounted (005-070)**

**General Information**

**Need For KSB on 1988 VE Pumps**

Emission requirements for 1988 prompted the need for a cold start timing advance system (KSB) to minimize white smoke.

After the engine starts, the wax motor-style KSB fully advances the ignition timing at low idle until the engine warms up. The KSB is **not** functional after the engine reaches 71°C [160°F] coolant temperature.

**KSB Hardware Definition**

There are currently two versions of pump-mounted wax motor-style KSBs released in the Cummins system and one remote-mounted version. The remote-mounted option is necessary in applications where the pump-mounted KSB causes interference with the air compressor.

**Pump-Mounted KSB**

The early pump-mounted KSB is a different design using two control lines. The two-line version was superseded in mid-1988 with a one-control-line version, which is the design used for both production and service at the moment.

There is no remote-mounted hardware available for the two-control-line KSB, so they can **not** be remote mounted.

The illustration shows a two-control-line KSB

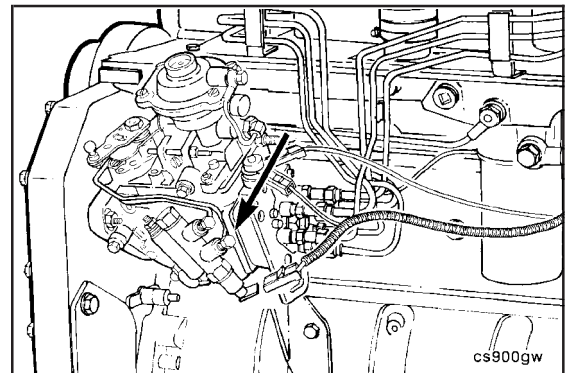

The illustration shows a one-control-line KSB

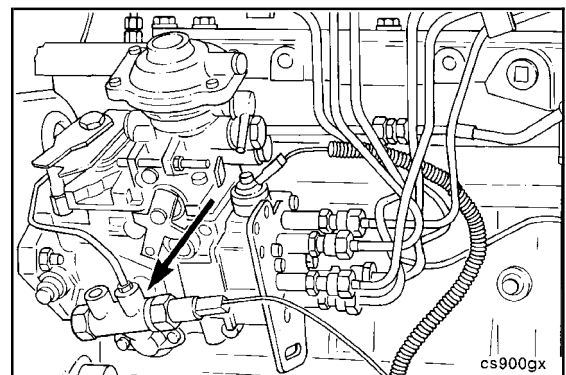

**Cold Start Timing Advance System (KSB)**



**Wax Motor-Style**

The wax motor-style KSB is used on pre-1991 B Series automotive engine ratings using the Bosch® VE fuel pump.

**NOTE:** The electrical solenoid-style KSB is used on 1991 model and newer B Series automotive engine ratings using the Bosch® VE fuel injection pump. Refer to Procedure 005-046, Cold Start Timing Advance System (KSB) - Electrical Solenoid Style, for additional information.

**Cold Start Timing Advance System (KSB)**

**Electrical Solenoid Style**

The electrical solenoid-style KSB is used on 1991 model and newer B Series automotive engine ratings using the Bosch® VE fuel pump.

**NOTE:** The wax motor-style KSB is used on pre-1991 B series automotive engine ratings using the Bosch® VE fuel pump. Refer to Procedure 005-070, Cold Start Timing Advance System (KSB) - Wax Motor Style, for additional information.

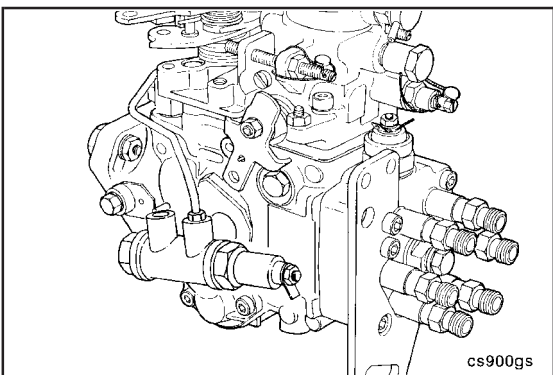

**Wax Motor-Style KSB**

**NOTE:** The temperature switch is located in the coolant jacket.

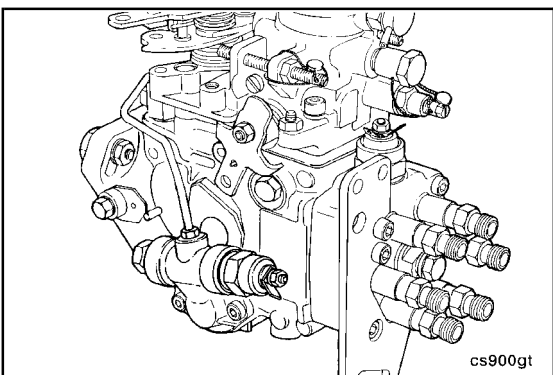

**Electrical Solenoid-Style KSB**

**NOTE:** The temperature switch is located in the intake manifold.

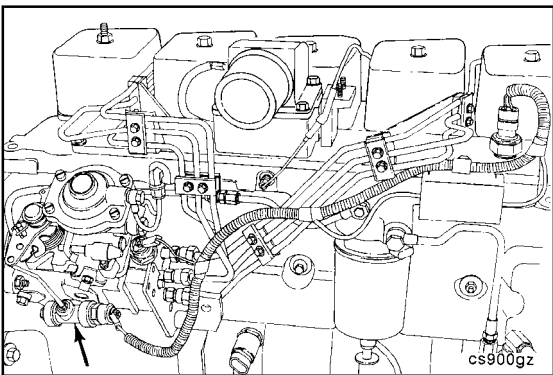

Two types of electrical solenoid-style KSB valves are available.

The first type is the pump-mounted KSB, as shown.

The second type is a remote-mounted KSB, as shown.  
 The remote-mounted KSB is used on the B Series automotive engines that have an air compressor.

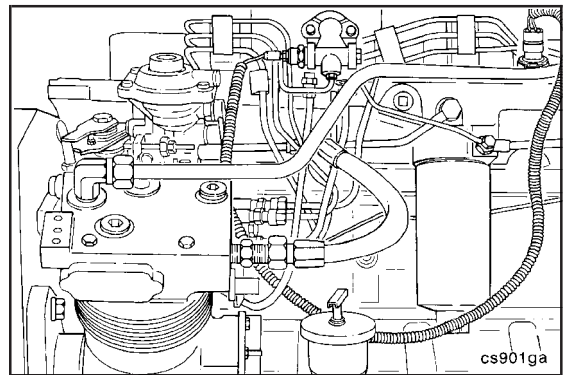

Both the four- and six-cylinder have the temperature switch mounted in the intake manifold as shown.

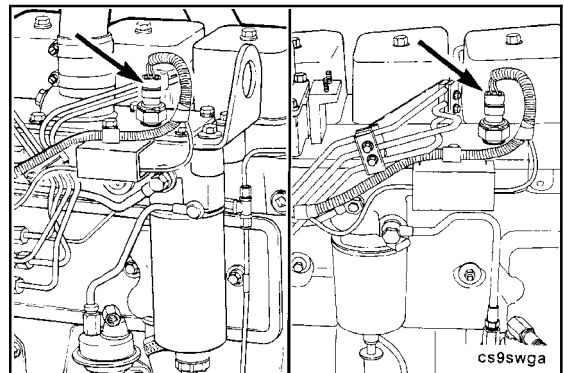

**Pump-Mounted Wax Motor-Style KSB**

1. KSB (one control line).
2. Wiring Harness  
 Cummins Part No. 3918364 (4B)  
 Cummins Part No. 3918431 (6B).
3. 71°C [160°F] Temperature Switch, Cummins Part No. 3915945

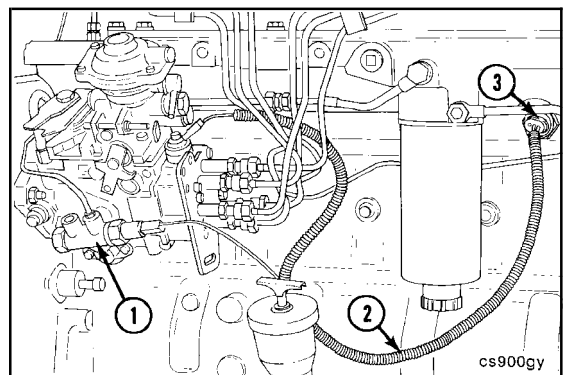

**Resistance Check (005-070-038)**

**Wax-Motor Style**

The wiring harness used on the wax motor-style KSB can be inspected using a multimeter.

**NOTE:** Pin C of the metro-pack connector is blank on the wax motor-style KSB wiring harness.

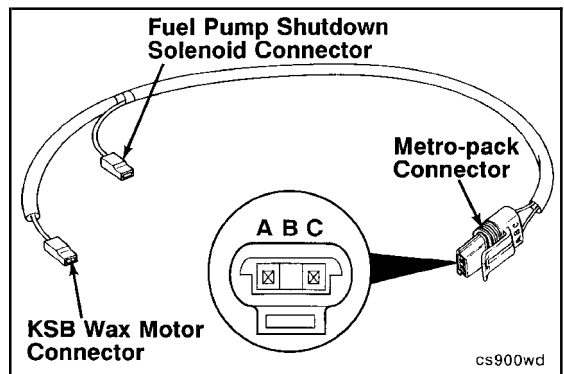

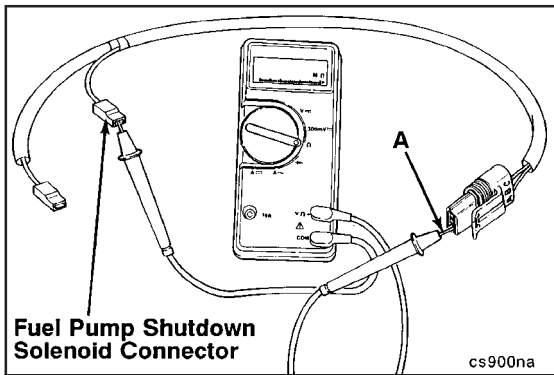

Use a multimeter to perform a continuity check between port A of the metro-pack connector and the female spade connector at the fuel pump shutdown solenoid connector.

Repair the wire if there is an open circuit.

Ohms Resistance - Less than 10.

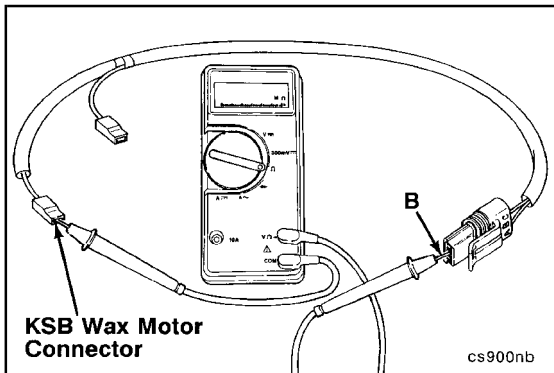

Use a multimeter to perform a continuity check between port B of the metro-pack connector and the female spade connector at the KSB wax motor connector.

Repair the wire if there is an open circuit.

Ohms Resistance - Less than 10.

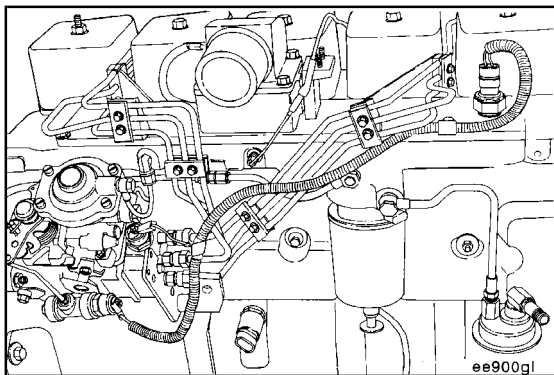

**Electrical Solenoid Style**

Engines with CPL 1579 do **not** have a resistor in the harness.

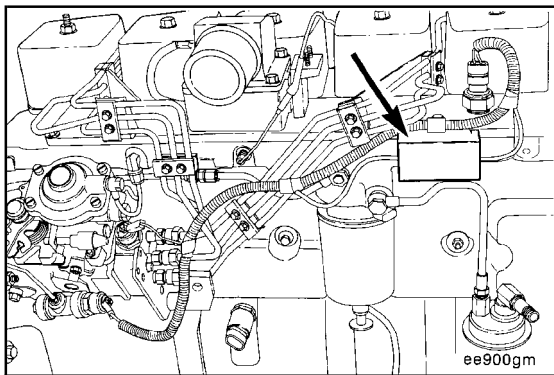

Engines with CPL 1351 **must** be wired with the resistor in the harness.

The wiring harness used on the electric solenoid-style KSB can be inspected using a multimeter.



**NOTE:** Pin B of the metro-pack connector is blank on the electric solenoid-style KSB wiring harness.

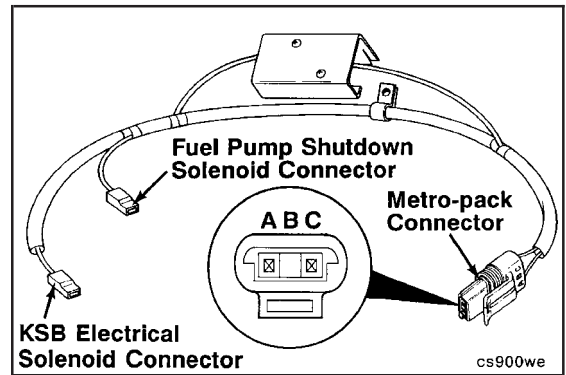

The electric solenoid-style KSB wiring harness contains a 3-ohm resistor in the wire leading from port C of the metro-pack connector to the KSB electrical solenoid connector.

The 3-ohm resistor is mounted to a bracket that is used as a heat sink to absorb heat that is generated by the resistor.

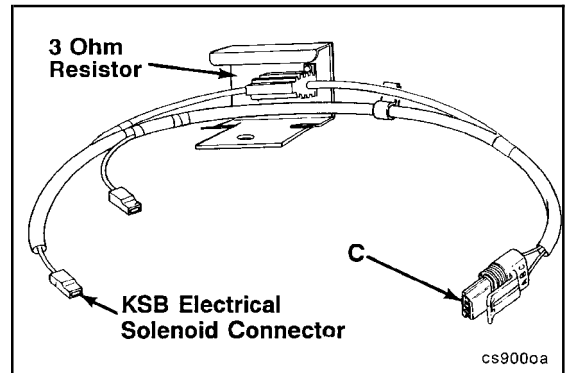

Use a multimeter to perform a continuity check between port C of the metro-pack connector and the KSB electrical solenoid connector.



Repair the wire if there is an open circuit.

(Spec = Less than 10 ohms).

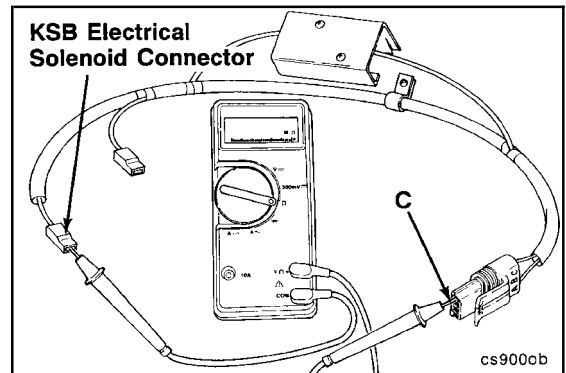

Use a multimeter to perform a continuity check between port A of the metro-pack connector and the fuel pump shutdown solenoid connector.



Repair the wire if there is an open circuit.

(Spec = Less than 10 ohms).

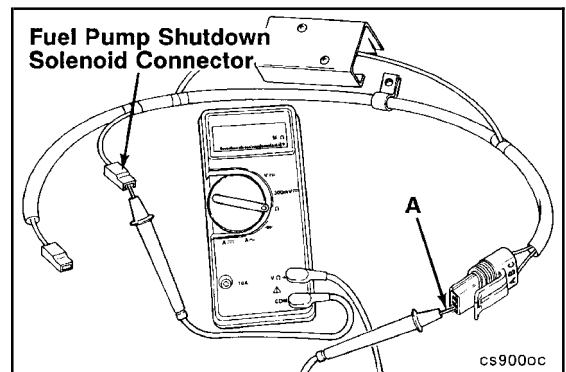

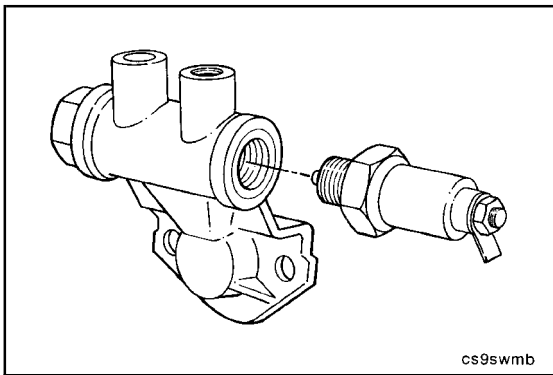

**Disassemble (005-070-003)**

22 mm



Loosen and remove the KSB electrical element from the KSB housing if equipped with a wax motor-style KSB.

**NOTE:** If equipped with an electrical solenoid-style KSB, proceed to the next step.

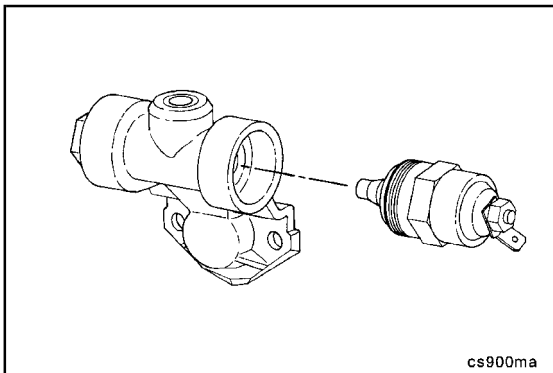

24 mm

Remove the KSB electrical solenoid from the KSB housing.

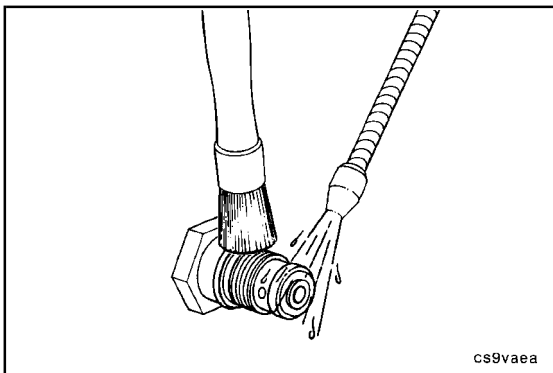

**Clean (005-070-006)**

**▲ WARNING ▲**

When using solvents, acids, or alkaline materials for cleaning, follow the manufacturer's recommendations for use. Wear goggles and protective clothing to avoid personal injury.

**▲ WARNING ▲**

Wear appropriate eye and face protection when using compressed air. Flying debris and dirt can cause bodily injury.

Thoroughly flush the pressure relief valve with cleaning solution.

Dry with compressed air.

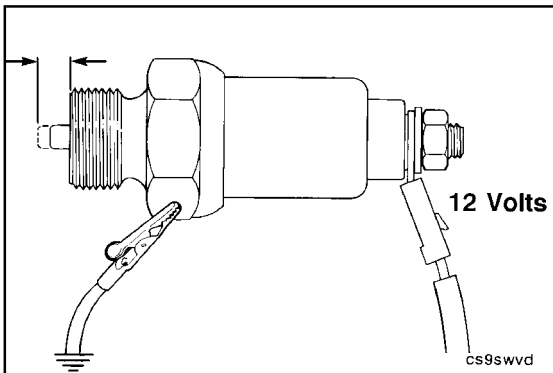

**Test (005-070-012)**

**KSB Electric Element**

Apply 12 VDC to the electrical terminal and a ground strap to the hexagonal portion of the element. Look for extensional movement of the plunger. If the plunger does **not** move after approximately 1 minute, check to make sure the element has been correctly connected to ground. If all connections are correct and the plunger does **not** move, the element is defective and **must** be replaced.

**NOTE:** The amount of plunger movement will vary depending upon the ambient temperature.



**KSB Electric Solenoid**

Apply 12 VDC to the electrical terminal, and ground the hexagonal portion of the element. The magnetic coil of the solenoid **must** push the plunger outward.

If the plunger does **not** push outward when voltage is applied, the solenoid is defective and **must** be replaced.

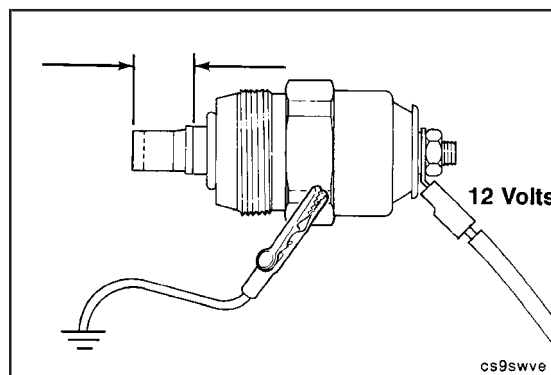

**Assemble (005-070-025)**

22 mm

Install the original element or a replacement into the KSB housing.

**Torque Value:** 22 N•m [16 ft-lb]

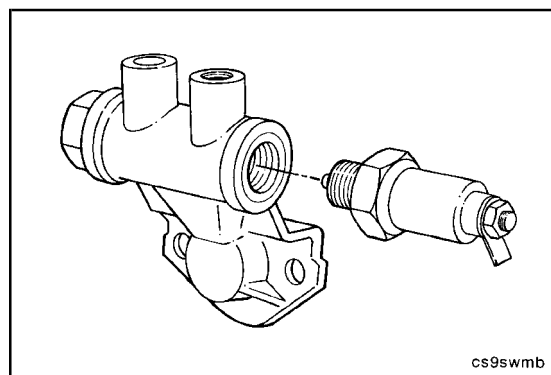

24 mm

Install the original solenoid or a replacement into the KSB housing.

**Torque Value:** 22 N•m [16 ft-lb]

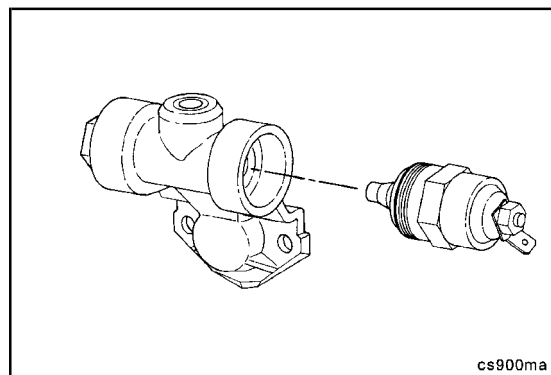



## Section 6 - Injectors and Fuel Lines - Group 06



### Section Contents

	Page
<b>AFC Air Tube</b> .....	6-2
Inspect for Reuse.....	6-2
Install.....	6-2
Remove.....	6-2
<b>Air in Fuel</b> .....	6-3
General Information.....	6-3
Measure.....	6-4
Test.....	6-5
<b>Fuel Drain Line Restriction</b> .....	6-5
Measure.....	6-5
<b>Fuel Filter (Spin-On Type)</b> .....	6-8
Install.....	6-9
Remove.....	6-8
<b>Fuel Inlet Restriction</b> .....	6-9
Initial Check.....	6-9
<b>Fuel Manifold (Drain)</b> .....	6-10
Clean.....	6-12
General Information.....	6-10
Inspect for Reuse.....	6-12
Install.....	6-13
Preparatory.....	6-11
Remove.....	6-11
<b>Fuel Return Overflow Valve</b> .....	6-33
Clean.....	6-34
Initial Check.....	6-33
Install.....	6-34
Remove.....	6-34
<b>Fuel Supply Lines</b> .....	6-14
Install.....	6-16
Remove.....	6-14
Vent.....	6-18
<b>Fuel-Water Separator</b> .....	6-32
General Information.....	6-32
<b>Injector</b> .....	6-20
Assemble.....	6-29
Clean.....	6-24
Disassemble.....	6-22
General Information.....	6-20
Inspect for Reuse.....	6-26
Install.....	6-30
Measure.....	6-26
Preparatory.....	6-21
Remove.....	6-21
Test.....	6-27
<b>Injector Supply Lines (High Pressure)</b> .....	6-34
Clean.....	6-38
General Information.....	6-34
Initial Check.....	6-36
Inspect for Reuse.....	6-38
Install.....	6-39
Remove.....	6-36
<b>Service Tools</b> .....	6-1
Injectors and Fuel Lines.....	6-1

**THIS PAGE LEFT INTENTIONALLY BLANK**

## Service Tools Injectors and Fuel Lines

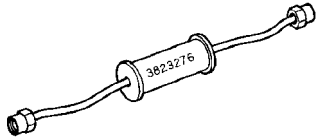
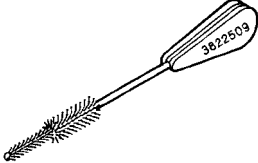
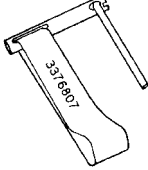
The following special tools are recommended to perform procedures in this section. The use of these tools is shown in the appropriate procedure. These tools can be purchased from your local Cummins Authorized Repair Location.

Tool No.	Tool Description	Tool Illustration
3823276	<b>Injector Puller</b> Used to pull the injector.	
3822509	<b>Injector Bore Brush</b> Used to clean the injector bore.	
3376807	<b>Filter Wrench</b> Used to remove spin-on filters.	
3824879	<b>Anti-seize Lubricant</b> Used to speed assembly and disassembly of studs, bolts, and so forth.	

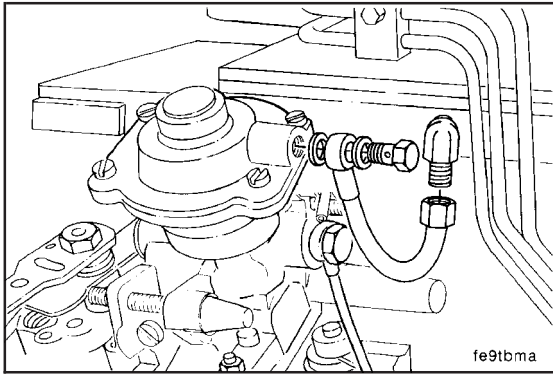

**AFC Air Tube (006-001)**

**Remove (006-001-002)**



**12 mm, 1/2 Inch**

**Distributor-Type Fuel Injection Pumps**

Remove the fuel tube from the manifold fitting and the pump.

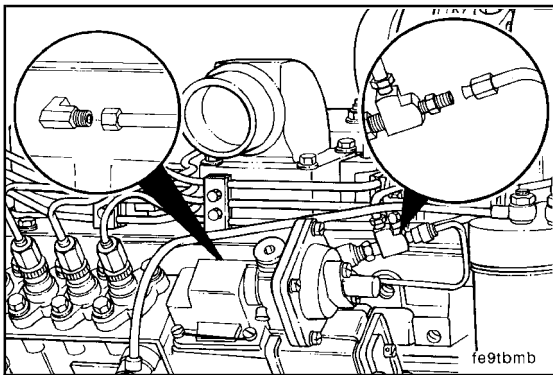

**In-Line Pumps**

**13 mm**

Remove the AFC tube.

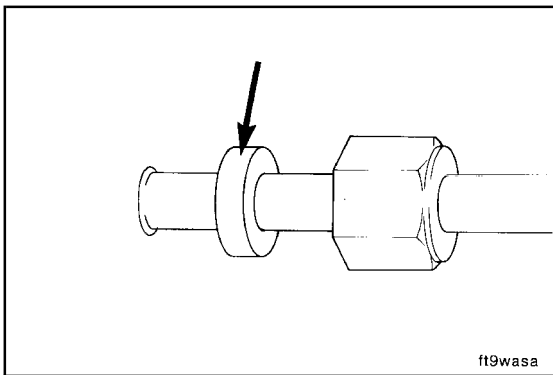

**Inspect for Reuse (006-001-007)**

**In-Line Pump**

Inspect the rubber sealing washers, and replace as necessary.

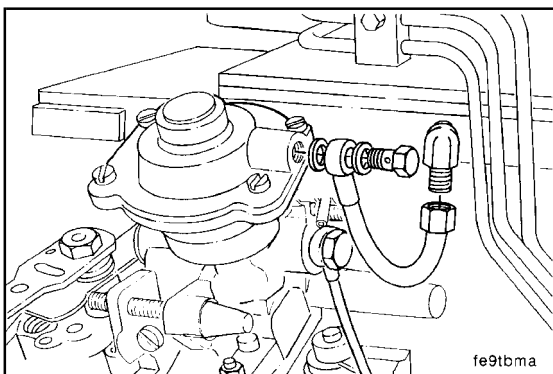

**Install (006-001-026)**

**Distributor-Type Pump**

**NOTE:** Use new sealing washers when installing the tube.

Assemble in the reverse order of removal.

**Torque Value:** 9 N•m [80 in-lb]



**In-Line Pump**

Install the AFC tube in the reverse order of removal.

**Torque Value:** 24 N•m [18 ft-lb]

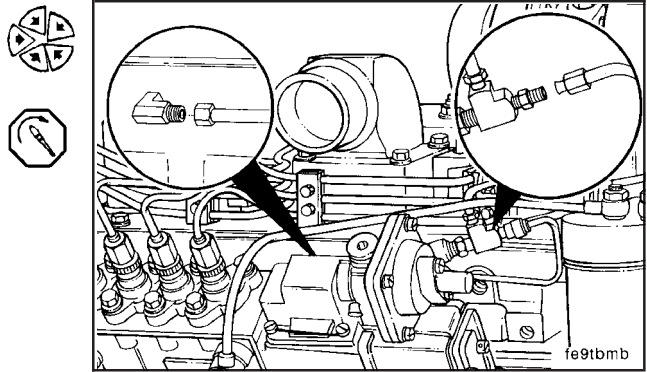

**Air in Fuel (006-003)**

**General Information**

Replacing the fuel supply lines, fuel filters, fuel injection pump, high-pressure fuel lines, and injectors will let air enter into the fuel system. Follow the specified procedure to bleed the air from the system.

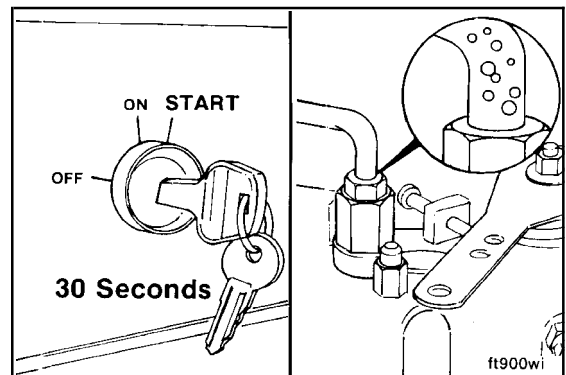

Since the fuel transfer pump provides positive pressure through the fuel filter and supply line to the fuel injection pump, loose connections or defective seals show as a fuel leak and **not** as an air leak.

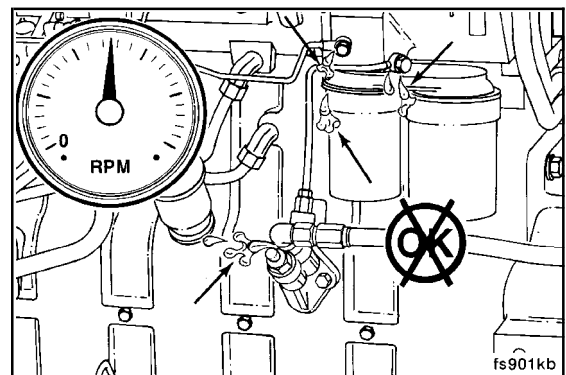

Air in the fuel system will cause the following engine problems:

- Hard to start
- Run rough
- Misfire
- Fuel knock.

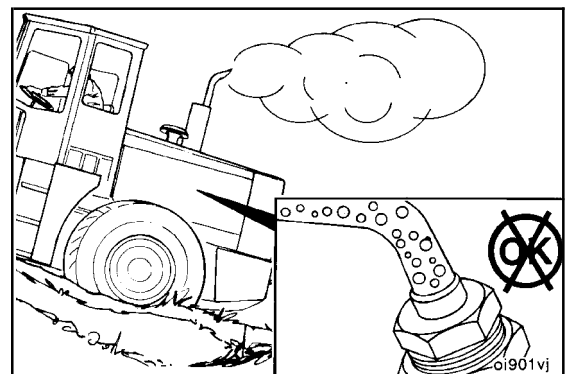

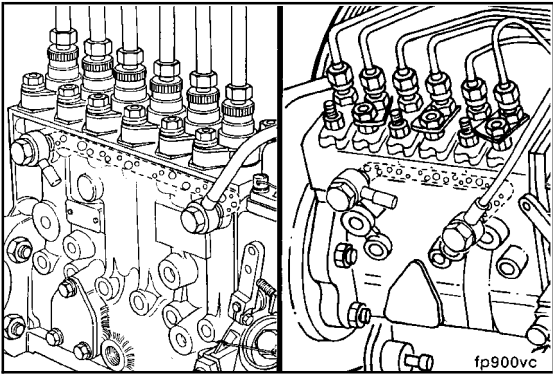

The MW, A, and P fuel injection pumps equipped with the engine-side fuel drain arrangement create a self-bleeding system for air introduced during replacement of the supply-side components.

For faster air purge, small amounts of air can be bled from the pump by operating the hand primer on the fuel transfer pump or by cranking the engine.

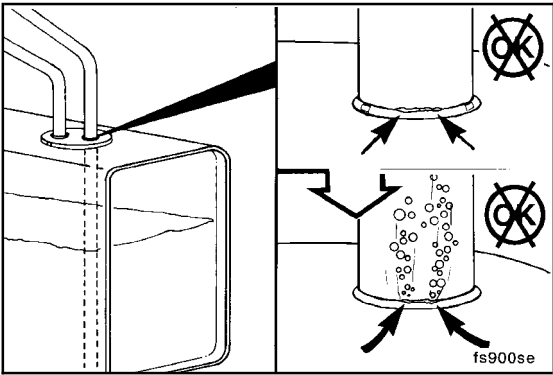

A source that is often overlooked for air to enter the fuel system is between the inlet of the prefilter and the suction tube in the tank. Fuel tanks that have the outlet fitting at the top have a suction tube that extends to the bottom of the tank. Cracks or pin holes in the weld that join the tube to the fitting can let air enter the fuel system.

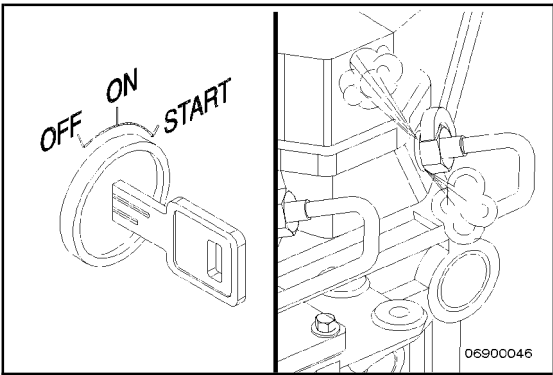

**Measure (006-003-010)**

19 mm



**⚠ WARNING ⚠**

**Keep hands and body parts away from the high-pressure fuel lines. Fuel coming from the high-pressure fuel lines are under extreme pressure and can cause serious injury by penetrating the skin.**

Check for air in the high-pressure lines by loosening the fittings at the head. Crank the engine to allow entrapped air to bleed from the line. Tighten the fittings.

**Torque Value:** 38 N•m [28 ft-lb]

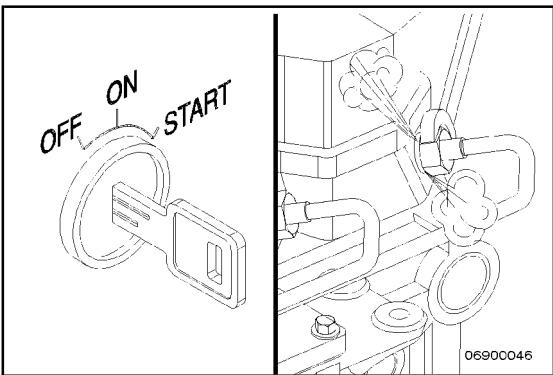

**⚠ CAUTION ⚠**

**Do not bleed the fuel system on a hot engine; this can cause fuel to spill onto a hot exhaust manifold, which can cause a fire.**

Operate the engine, and vent one line at a time until the engine runs smoothly.



**Test (006-003-012)**

A replacement of fuel supply lines, fuel filters, fuel injection pump, high-pressure fuel lines, and injectors will let air enter the fuel system. Air in the system will make the engine hard to start, run rough, misfire, produce low power, and can cause excessive smoke and a fuel knock.

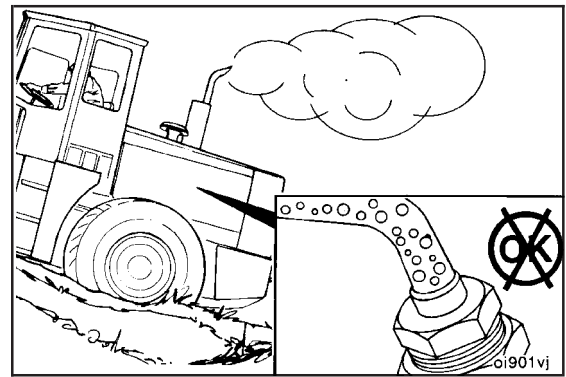

**NOTE:** If an excessive amount of air has entered into the system, the system will need to be bled.

Loosen the return banjo fitting on the fuel lift pump. Run the fuel lift pump until all the air has been bled. When all the air has been bled, retighten the fitting.

**NOTE:** To run the fuel pump for 25 seconds, crank the engine for a split second, and leave the key in the ON position.

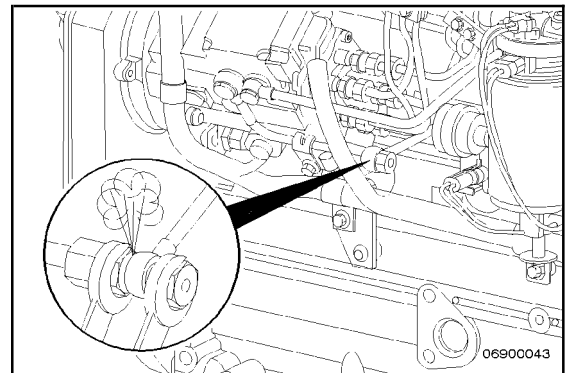

If air continues to bubble out of the system for several minutes, then an air leak is present.

An often overlooked source from which air can enter the fuel system is between the inlet of the fuel transfer pump and the suction tube in the tank. Fuel tanks that have the outlet fitting at the top will have a suction tube that extends to the bottom of the tank. Cracks or pin holes in the weld that join the tube to the fitting can let air enter the fuel system.

Also, check to make sure all the fittings from the fuel supply line on the tank to the inlet of the fuel transfer pump are tight.

Use a sight glass at the fuel lift pump inlet to check for air in the fuel supply lines.

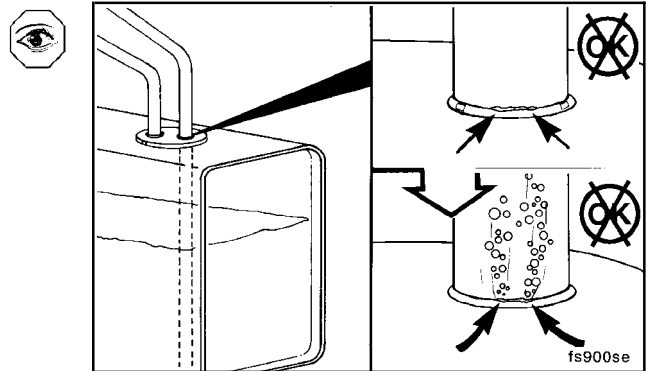

**Fuel Drain Line Restriction (006-012)**

**Measure (006-012-010)**

10 mm

Remove the capscrews from the hold-down clamps, and complete the following steps:

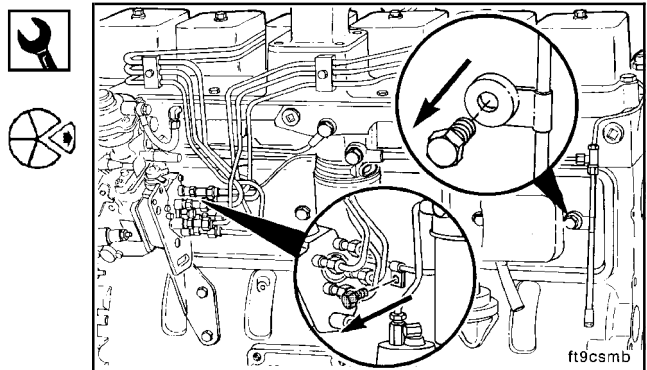

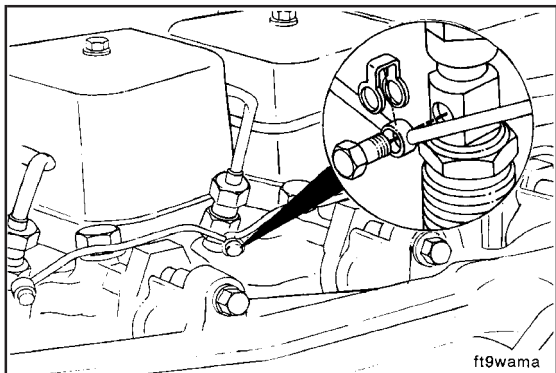

Remove the banjo fitting capscrews and washers.

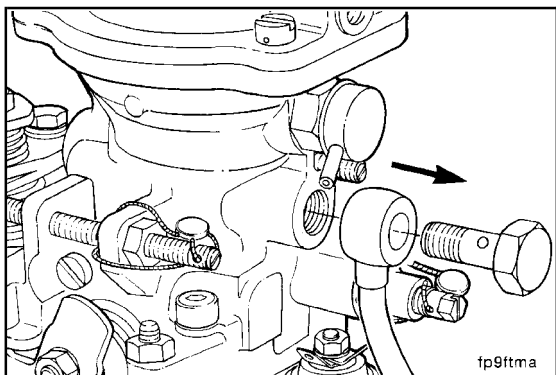

17 mm

Disconnect the fuel drain line fittings.

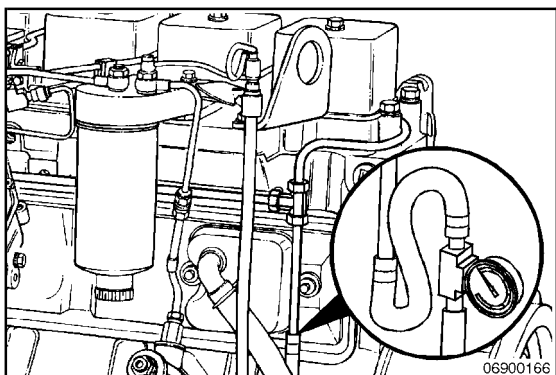

Install the 0 to 207-kPa [0 to 30-psi] pressure gauge.

**NOTE:** The disconnected return line tee (return from the pump) needs to be capped.

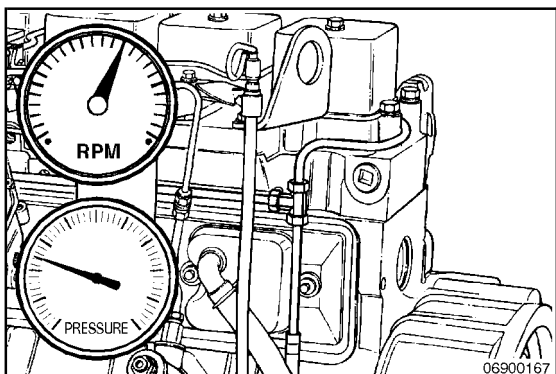

Operate the engine at rated speed and no load.

**B3.9 and B5.9 Series Engines**  
**Section 6 - Injectors and Fuel Lines - Group 06**

Observe the reading on the gauge.

Fuel Drain Line Restriction		
mm Hg		in Hg
518	MAX	20.4

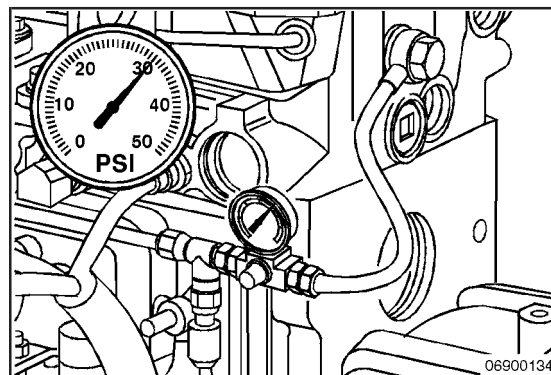

If the drain line pressure is out of specification, check for bends or kinks in the drain lines.

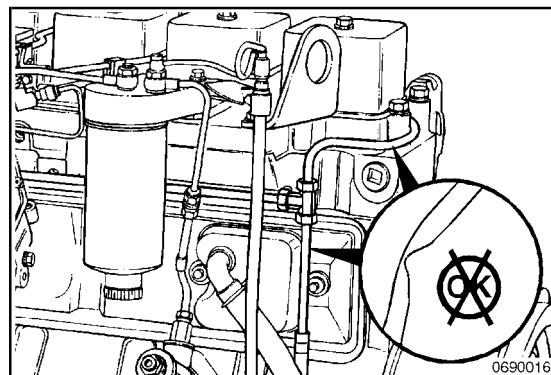

Assemble the fuel drain line and fuel drain manifold in the reverse order of disassembly.

**NOTE:** Use new seals for the drain line fittings.

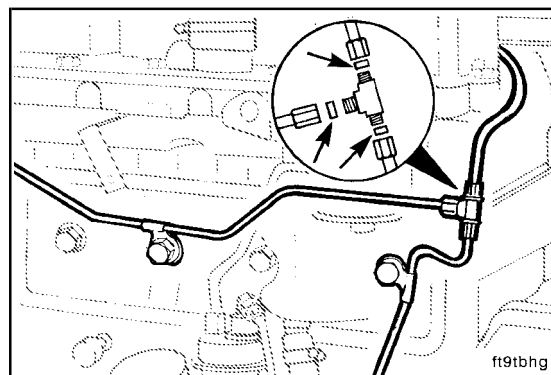

Install the banjo fitting capscrews.

**Torque Value:** 9 N•m [80 in-lb]

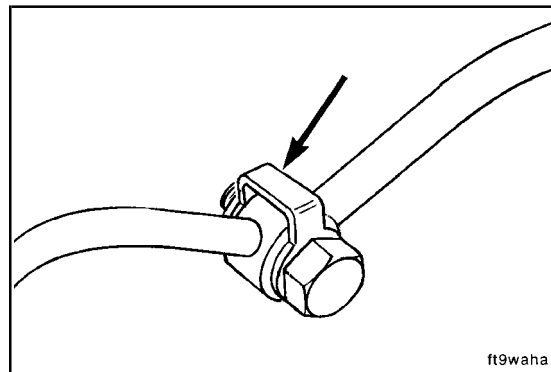

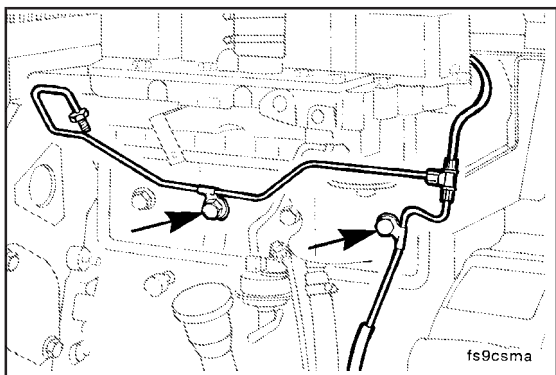

Install the clamp capscrews.

**Torque Value:** 24 N•m [18 ft-lb]

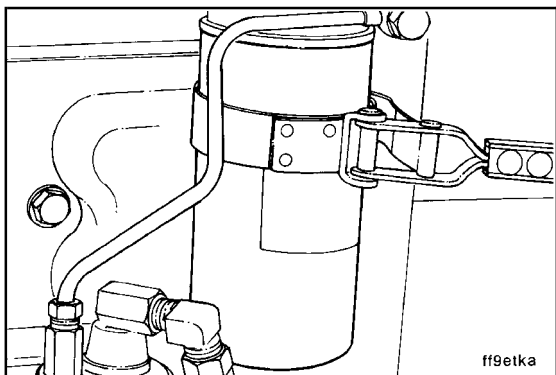

**Fuel Filter (Spin-On Type) (006-015)**

**Remove (006-015-002)**



80 to 95 mm, Filter Wrench, Part No. 3376807

Remove the combination water separator/fuel filter.

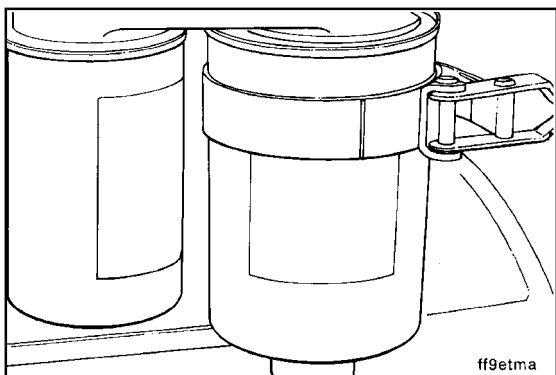

80 to 95 mm, Filter Wrench, Part No. 3376807

Remove the two filters from the dual-filter adapter (if equipped).

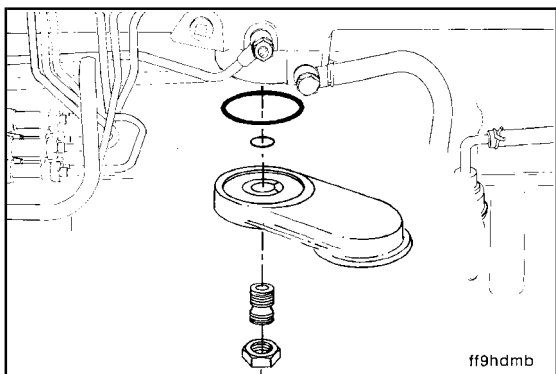

24 mm, Flat-Blade Screwdriver

If a leak is found, replace the o-rings.

**Torque Value:** 32 N•m [24 ft-lb]



Fill the new filter(s) with clean diesel fuel.

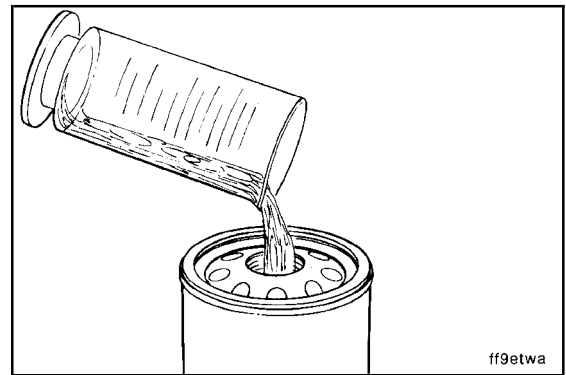

**Install (006-015-026)**

Lubricate the seal with clean lubricating engine oil.

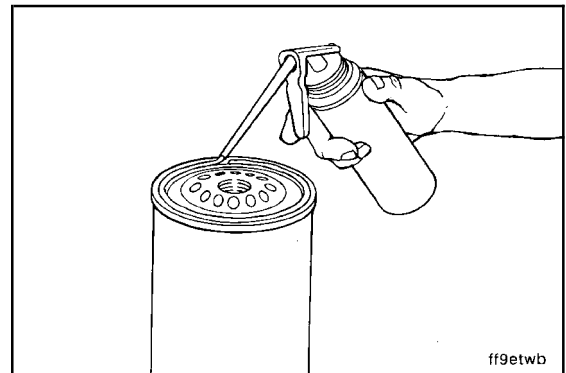

**⚠ CAUTION ⚠**

**Mechanical overtightening can distort the threads as well as damage the filter element seal or filter can.**

Install the fuel filter on the fuel filter head. Turn the filter until the gasket contacts the filter head surface.

Tighten the fuel filter an additional  $\frac{1}{2}$  to  $\frac{3}{4}$  of a turn after the gasket contacts the fuel filter head surface, or as specified by the fuel filter manufacturer.

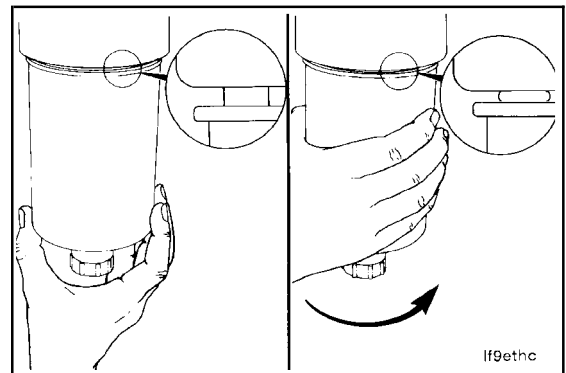

**Fuel Inlet Restriction (006-020)**

**Initial Check (006-020-001)**

Install a fitting at the inlet transfer pump.

Install a vacuum gauge that has a range of at least 0 to 508 mm Hg [0 to 20 in Hg].

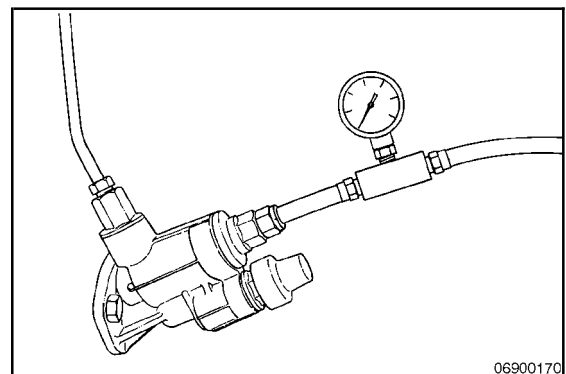

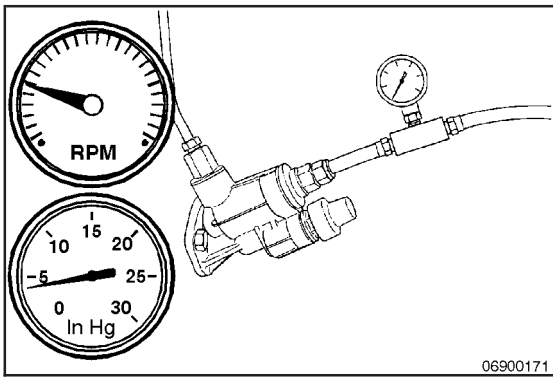

Start the engine, and run at low or high idle.

Allowable Inlet Restriction at Low/High Idle		
mm Hg		in Hg
101.6	MAX	4.0

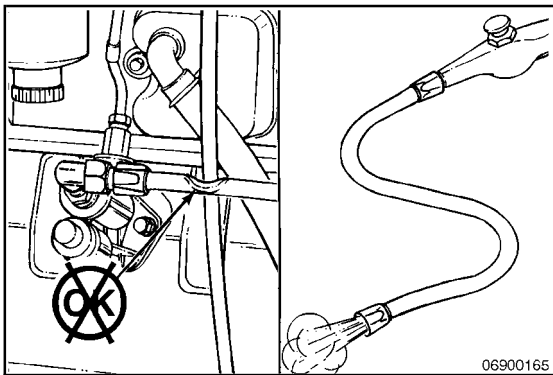

If the fuel inlet restriction is too high, check to make sure that the OEM lines from the tank are sized properly, there are no kinks or bends in the lines, and the lines are **not** clogged.

Make sure that there are no clogged fuel strainers or malfunctioning check valves.

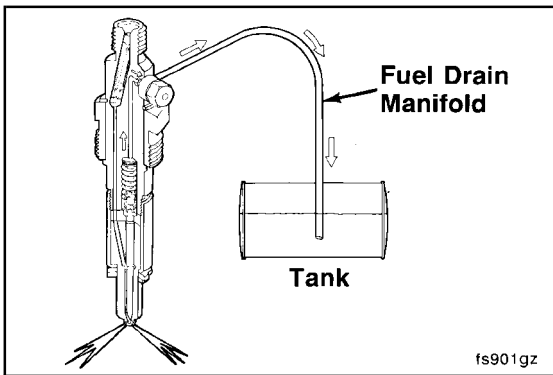

### Fuel Manifold (Drain) (006-021)

#### General Information

The fuel system is designed to use fuel to cool and lubricate the injection pump and injectors. Fuel is continually vented from the injection pump, and a small amount of fuel leaks near the injector needle valve during injection. This fuel is returned to the supply tank by the fuel drain manifold.

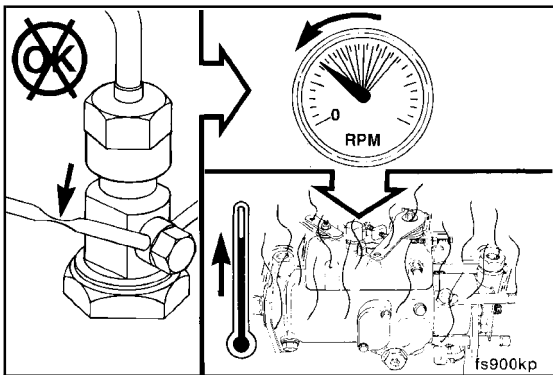

Restriction of the fuel drain manifold can affect the Lucas CAV DPA/DPS fuel injection pump metering controls and the operation of the injectors. Restricting the fuel drain manifold raises the case pressure of the fuel injection pump, which can prevent injection.

If the engine will restart after a waiting period following an unexplained shutdown, look for any restriction of the manifold drain line.

**NOTE:** Restriction can cause the fuel temperature to rise, reducing power from the engine.

**Preparatory (006-021-000)**

**▲ WARNING ▲**

When using solvents, acids, or alkaline materials for cleaning, follow the manufacturer's recommendations for use. Wear goggles and protective clothing to avoid personal injury.

- Clean any debris.

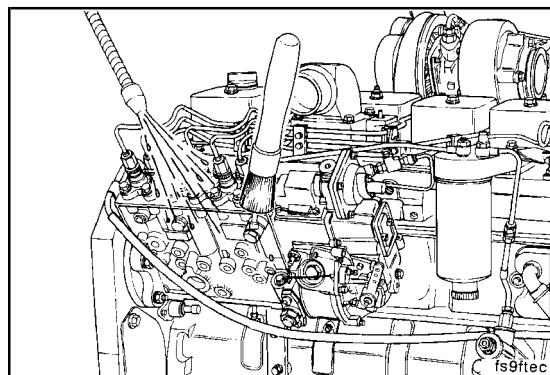

**Remove (006-021-002)**

10 mm

**Distributor-Type Pump**

Remove the capscrews from the hold-down clamps, and complete the following steps:

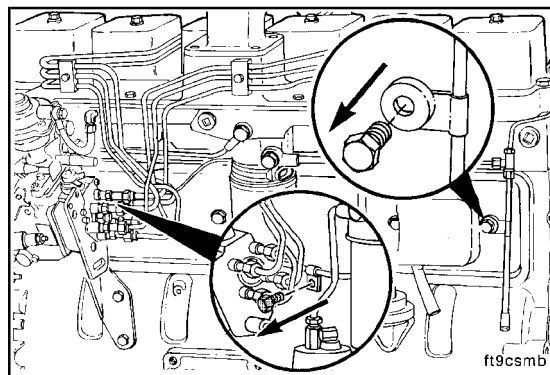

10 mm

Remove the banjo fitting capscrews and washers.

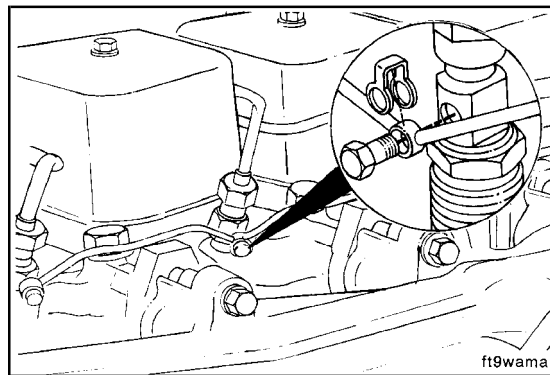

17 mm

Disconnect the fuel drain line fittings.

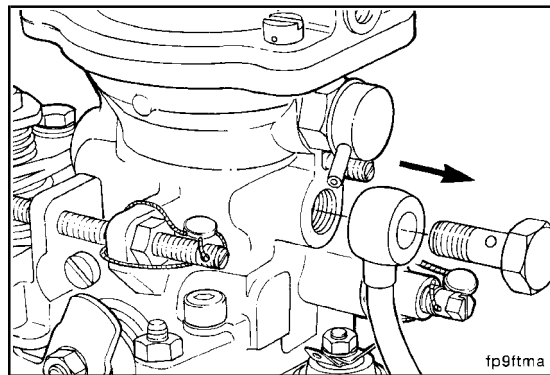

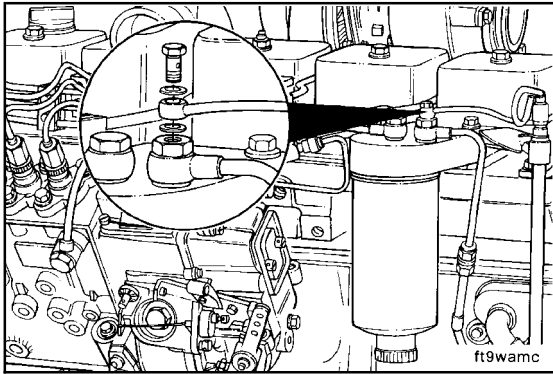

10 mm, 12 mm

**In-Line Pump**



Remove the banjo capscrews and copper sealing washers at the fuel filter head.

Remove the fuel line support bracket capscrew from the intake manifold.

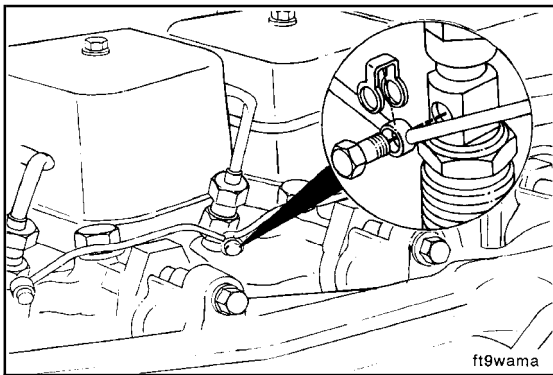

10 mm

Remove the banjo capscrews and copper sealing washers from the injectors.

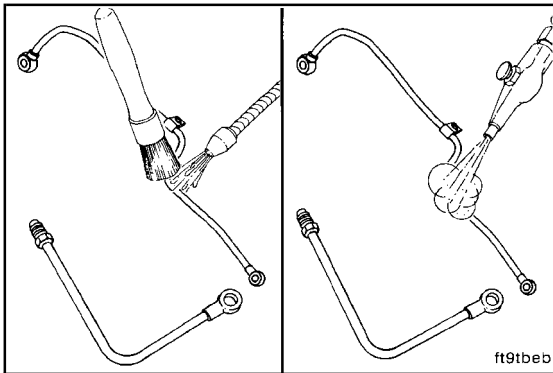

**Clean (006-021-006)**

**▲ WARNING ▲**

When using solvents, acids, or alkaline materials for cleaning, follow the manufacturer's recommendations for use. Wear goggles and protective clothing to avoid personal injury.

**▲ WARNING ▲**

Wear appropriate eye and face protection when using compressed air. Flying debris and dirt can cause bodily injury.

Wash the low-pressure fuel lines in solvent.

Dry the fuel lines with compressed air.

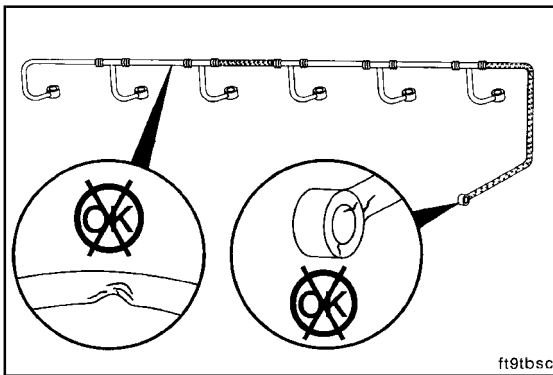

**Inspect for Reuse (006-021-007)**

Inspect the fuel drain manifold for cracks and other damage.



**B3.9 and B5.9 Series Engines**  
**Section 6 - Injectors and Fuel Lines - Group 06**

Inspect the fuel drain manifold banjo connections.

**NOTE:** The banjo connection seals **must** be discarded when removed. The seals **must not** be used again.

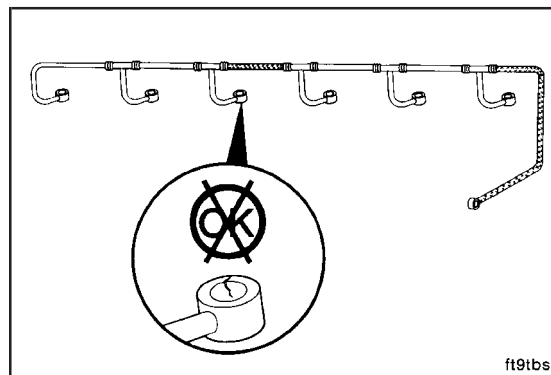

ft9tbsc

**Install (006-021-026)**

**Distributor-Type Pump**

Assemble the fuel drain line and fuel drain manifold in the reverse order of disassembly.

**NOTE:** Use new seals for the fittings.

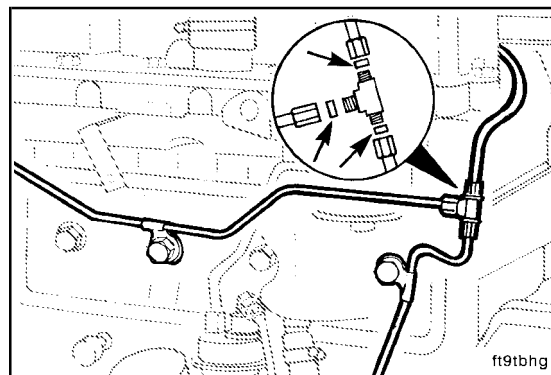

ft9tbhg

The installation torque for the banjo fitting screw is as follows:

**Torque Value:** 9 N•m [80 in-lb]

**NOTE:** Use new sealing washers for the fuel drain manifold.

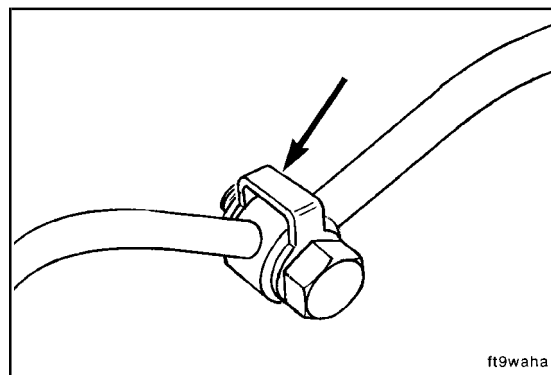

ft9waha

Install the clamp capscrews.

**Torque Value:** 24 N•m [18 ft-lb]

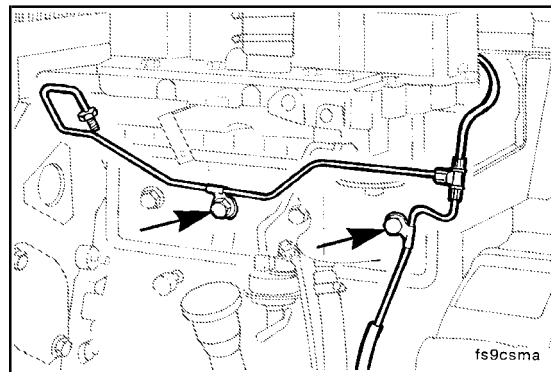

fs9csma

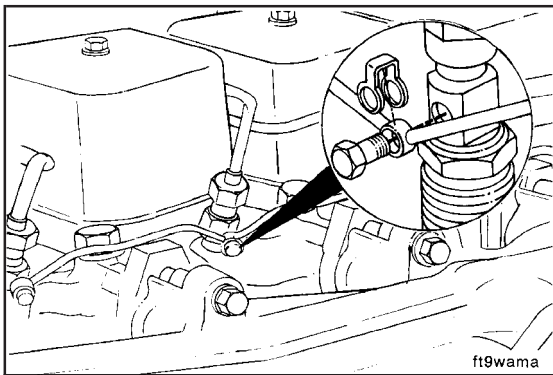

10 mm

**Bosch® In-Line pump**



Install the fuel drain manifold in the reverse order of removal.

**Torque Value:**

Injector Banjo 9 N•m [80 in-lb]

Fuel Filter

Head 13 N•m [115 in-lb]



**NOTE:** The fuel line support bracket capscrew in the intake manifold requires liquid teflon sealant.

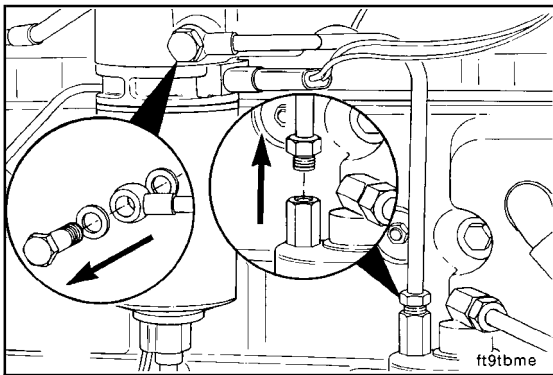

**Fuel Supply Lines (006-024)**

**Remove (006-024-002)**



14 mm and 17 mm

**Low-Pressure Fuel Line Replacement - Distributor-Type Pumps**

Remove the line from the fuel transfer pump and fuel filter head.

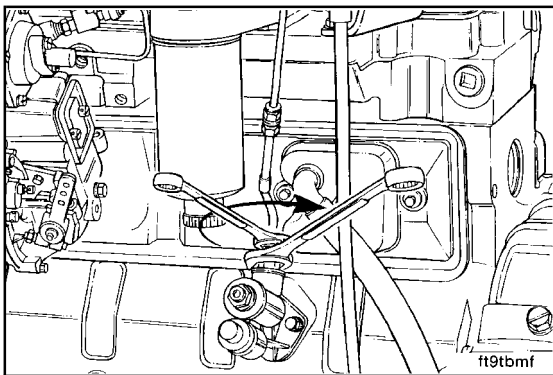

14 mm, 20 mm

**Bosch® In-Line Fuel Injection Pump Fuel Line**



Remove the fuel line from the piston-style fuel transfer pump.

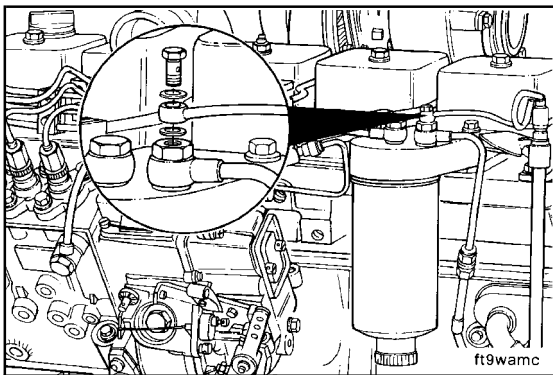

12 mm

Remove the fuel drain manifold line at the filter head.



17 mm

Remove the fuel line from the filter head.

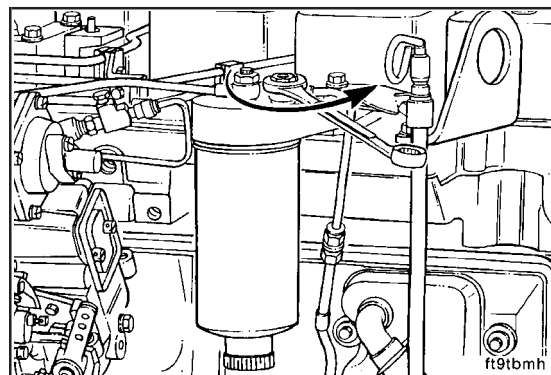

**Fuel Injection Pump Supply Line - Distributor-Type Pumps**

17 mm

Remove the bleed screw banjo fitting, and complete the following steps:

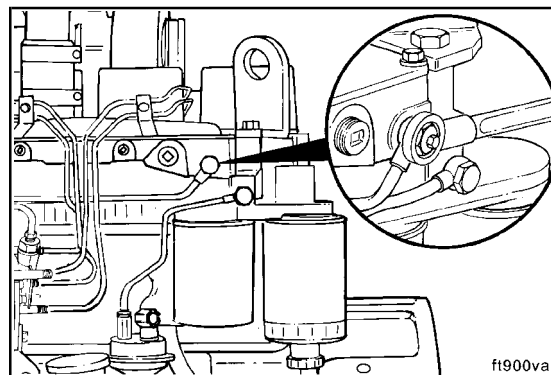

14 mm and 17 mm

Remove the fuel line from the Bosch® fuel injection pump fitting.

**NOTE:** To prevent loosening the fuel injection pump inlet fitting, use two wrenches when removing the fuel supply line.

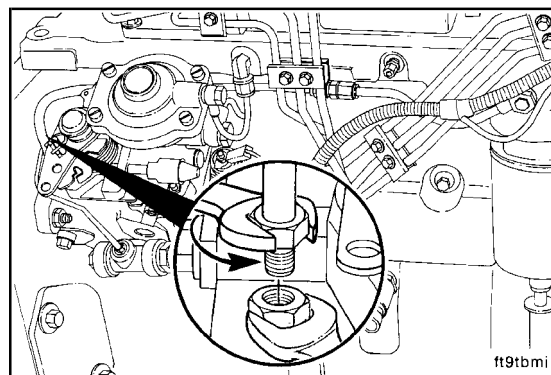

14 mm, 16 mm, 19 mm, and 24 mm

Remove the fuel supply line from the two Lucas CAV fuel injection pump fittings.

**NOTE:** Replace the seals in the fittings if the line is disassembled.

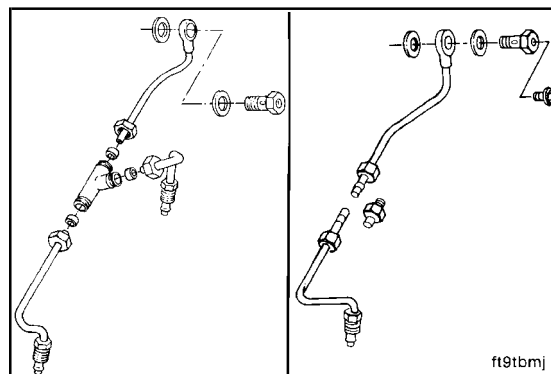

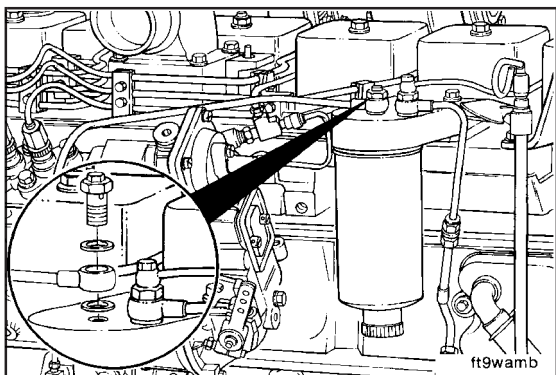

17 mm

**Pump Supply Line - Bosch® In-Line Pump**



Remove the banjo capscrew and sealing washers at the filter head.

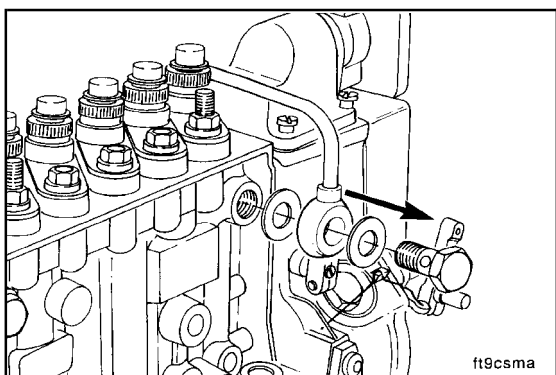

19 mm

Remove the banjo capscrew and copper sealing washer at the fuel injection pump inlet.

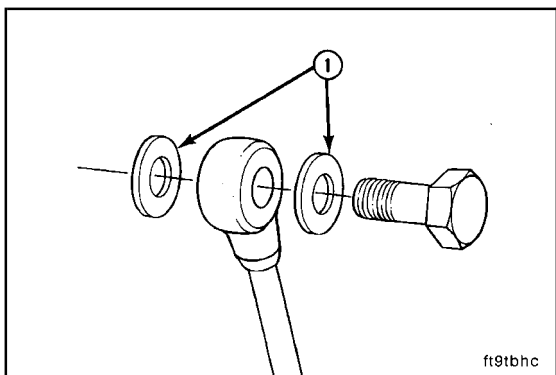

**Install (006-024-026)**

**Low-Pressure Fuel Line(s)**

**Distributor Pumps**

**NOTE:** When replacing the fuel lines, replace the banjo fitting sealing washers (1) each time they are removed.

Install the fuel line and tighten the fittings securely.

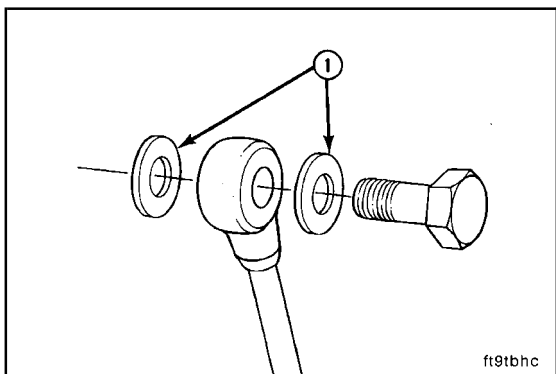

17 mm, 12 mm, 14 mm, and 20 mm

**Bosch® In-Line Pump**



**NOTE:** When replacing the fuel lines, replace the banjo sealing washers (1) each time they are removed.

Install the fuel line in the reverse order of removal.

10 mm, 17 mm

**In-Line Pumps**

Bleed the fuel line by opening the banjo bleed screw.

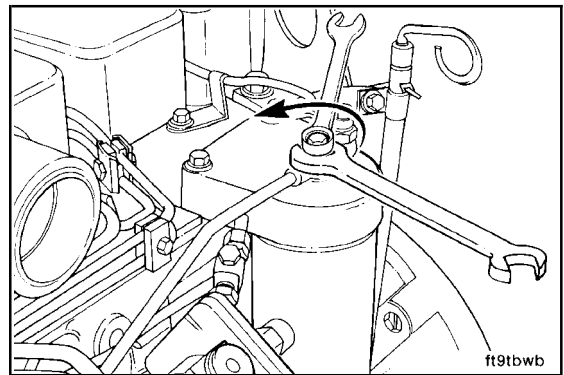

10 mm, 17 mm

Operate the priming button on the fuel transfer pump until the fuel flowing from the fitting is free of air.

Tighten the bleed screw.

**Torque Value:** 9 N•m [80 in-lb]

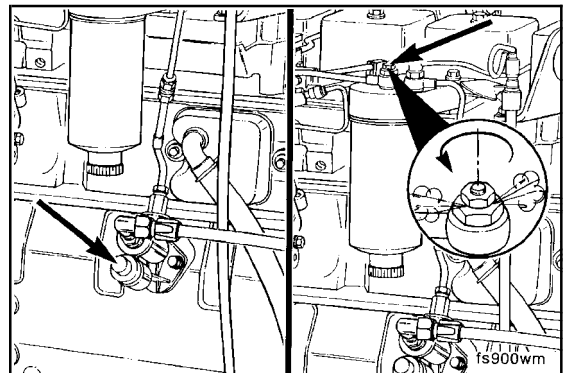

**High-Pressure Fuel Line(s)**

10 mm

**High-Pressure Fuel Line Replacement - Distributor-Type Pumps**

Assemble the fuel lines in the reverse order of removal.

**Torque Value:** 24 N•m [18 ft-lb]

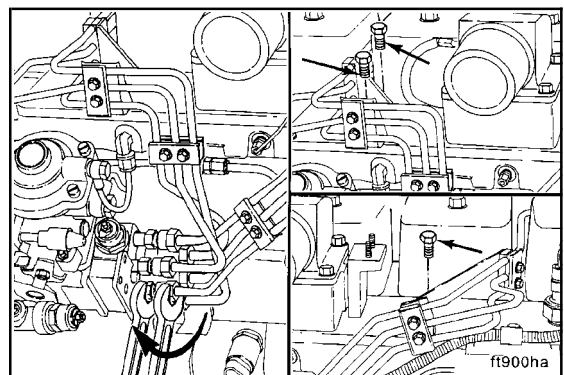

**⚠ WARNING ⚠**

**Do not bleed a hot engine as this would cause fuel to spill onto a hot exhaust manifold, creating a danger of fire.**

Operate the engine and vent one line at a time until the engine runs smoothly.

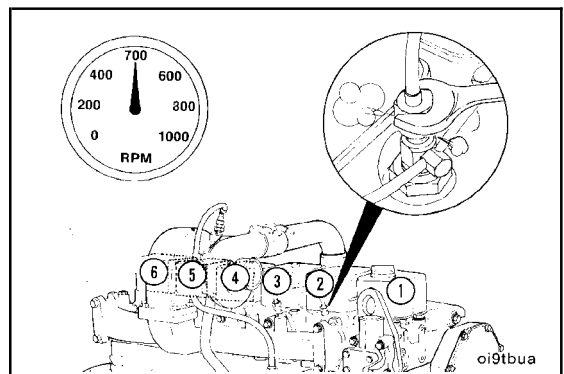

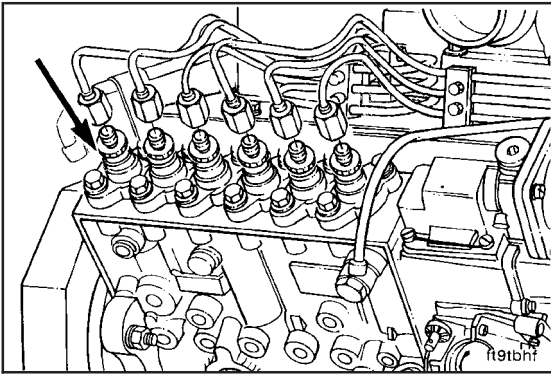

**High-Pressure Fuel Line - Bosch® In-Line Pump**

**NOTE:** If removed, reinstall the support clamp in the original position, and make sure the lines do **not** contact each other or another component.



Loosen the vibration isolator capscrews so the fuel lines can be easily moved.



**NOTE:** To prevent breakage to the fuel lines, they **must** be connected to the injector and fuel injection pump in a "free state" without forcing the connecting nuts. Since the fuel lines are properly sized for specific application, bending should **not** be necessary.



Install the fuel lines in the reverse order of removal.

**Torque Value:**

(Line Fittings)	24 N•m	[18 ft-lb]
(Support Clamp)	6 N•m	[35 in-lb]
(Support Bracket)	24 N•m	[18 ft-lb]

**NOTE:** The inside holes of the intake manifold are drilled through and require liquid teflon sealant.

**Vent (006-024-032)**

Controlled venting is provided at the injection pump through the fuel drain manifold. Small amounts of air introduced by changing the filters or injection pump supply line will be vented automatically if the fuel filter is changed in accordance with the instructions.

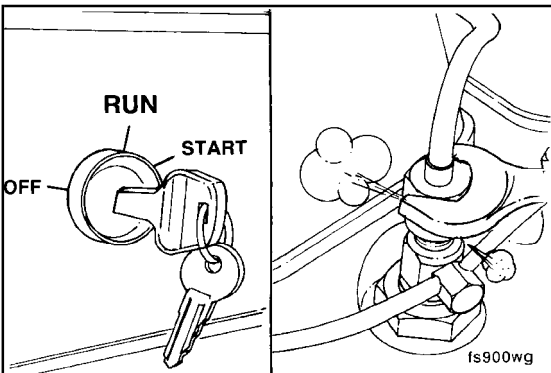
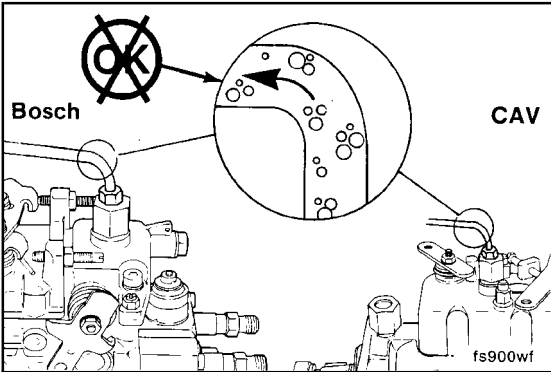

However, manual bleeding will be required if one of the following conditions exists:

- The fuel filter is **not** filled prior to installation.
- The fuel injection pump is replaced.
- The high-pressure fuel line connections are loosened, or the lines are replaced.
- It is an initial engine start-up or start-up after an extended period of no engine operation.

10 mm

Open the bleed screw.

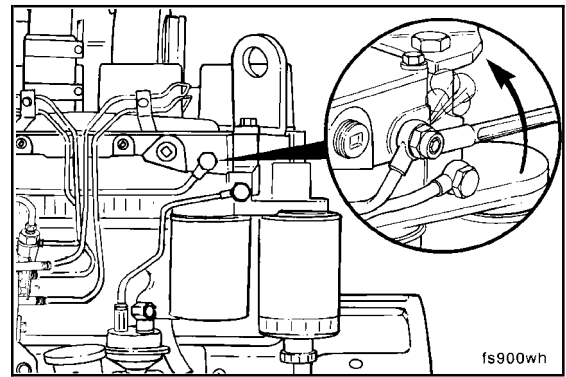

Operate the hand lever until the fuel flowing from the fitting is free of air.

Tighten the bleed screw.

**Torque Value:** 9 N•m [80 in-lb]

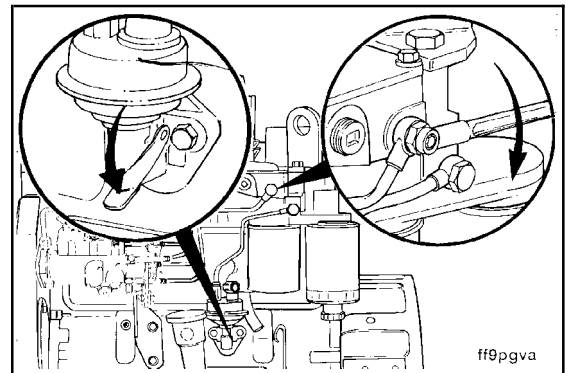

**Injection Pumps - Venting**

Air/fuel can be vented from the illustrated vent locations on the Nippondenso EP-9 and the Lucas CAV fuel injection pumps. The Lucas CAV fuel injection pump requires that the fuel solenoid valve be energized before venting.

Loosen the vent screw, and operate the priming lever on the fuel transfer pump until the fuel injection pump is primed. Tighten the vent screw.

**Torque Value:** 9 N•m [80 in-lb]

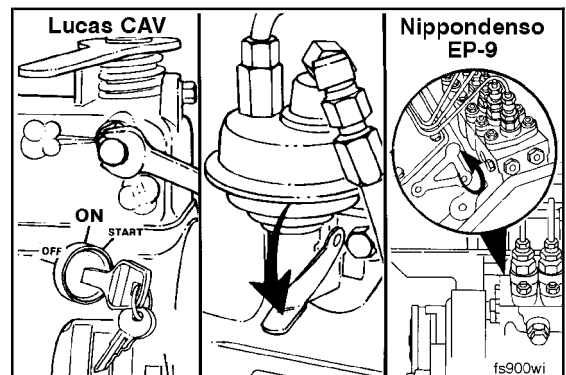

**⚠ CAUTION ⚠**

It is necessary to turn the keywitch to the ON position. Because the engine can start, be sure to follow all safety precautions. Use the normal engine starting procedure.

**⚠ CAUTION ⚠**

When using the starting motor to vent the system, do not engage it for more than 30 seconds, or starter damage will occur. Wait 2 minutes before starting the engine again.

Air can also be vented through the fuel drain manifold line by operating the starting motor.

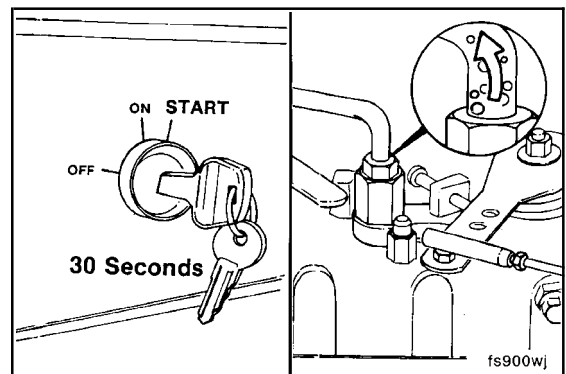

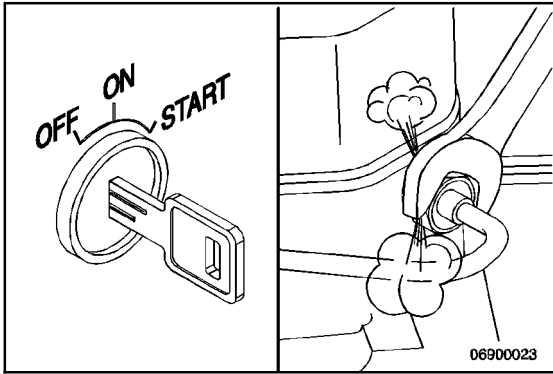

19 mm

High-Pressure Fuel Lines



**▲ WARNING ▲**

The pressure of the fuel in the line is sufficient to penetrate the skin and cause serious bodily harm.

Check for air in the high-pressure lines by loosening the fittings at the cylinder head, and crank the engine to allow entrapped air to bleed from the line. Tighten the fittings.

**Torque Value:** 40 N•m [30 ft-lb]

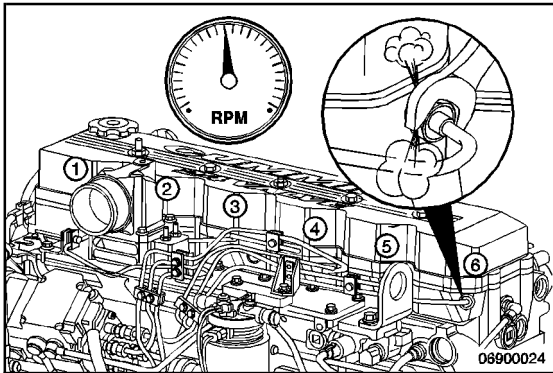

**▲ WARNING ▲**

Do not bleed a hot engine as this can cause fuel to spill onto a hot exhaust manifold, creating a danger of fire.

Operate the engine, and vent one line at a time until the engine runs smoothly.

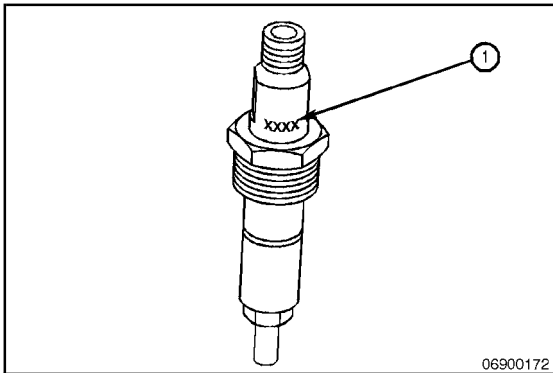

### Injector (006-026)

#### General Information

**▲ CAUTION ▲**

Use only the specified injector for the engine.

All engines use closed nozzle, hole-type injectors. However, the injectors can have different part numbers for different engine ratings. The last four digits of the Cummins part number are used to identify the injectors.

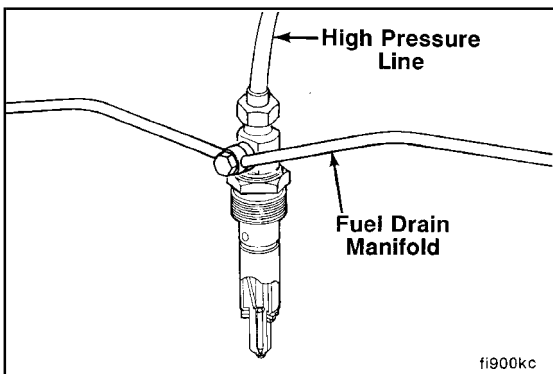

During the injection cycle, high pressure from the injection pump rises to the operating (pop) pressure, which causes the needle valve in the injector to lift. Fuel is then injected into the cylinder. A shimmed spring is used to force the needle valve closed as the injection pressure drops below the pop pressure to seal off the nozzle after injection.



**B3.9 and B5.9 Series Engines**  
**Section 6 - Injectors and Fuel Lines - Group 06**

Failure of the needle valve to lift and close at the correct time or needle valve stuck open can cause the engine to misfire and produce low power. Fuel leaking from the open nozzle can cause a fuel knock, poor performance, smoke, poor fuel economy, and rough running.

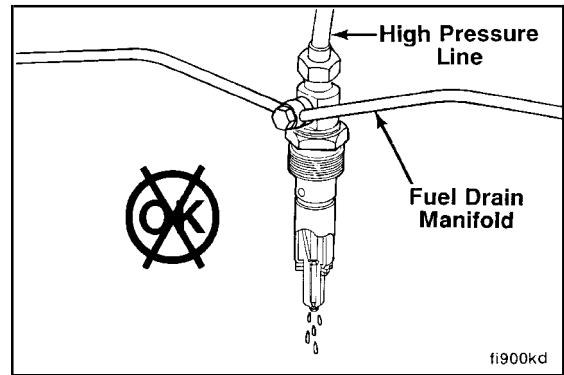

**Preparatory (006-026-000)**

- Clean around the injectors.
- Disconnect the high-pressure fuel supply lines.
- Disconnect the fuel drain manifold.

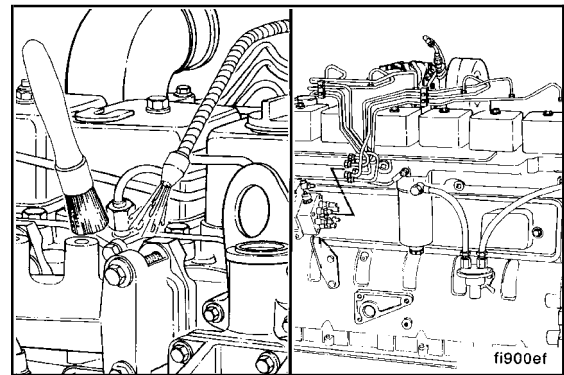

**Remove (006-026-002)**

**Rust-Penetrating Solvent**



**WARNING**

When using solvents, acids, or alkaline materials for cleaning, follow the manufacturer's recommendations for use. Wear goggles and protective clothing to avoid personal injury.



**CAUTION**

When rust has formed on the hold-down nut, the injector can turn in the bore when the nut is loosened. This can cause severe damage to the head by the injector locating ball cutting a groove in the bore.

Soak the hold-down nut with a rust-penetrating solvent for a minimum of 3 minutes.

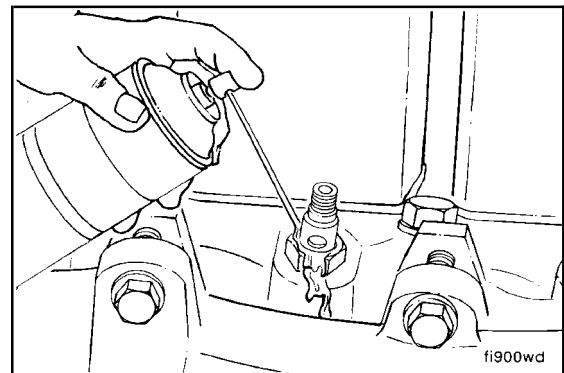

**Brass Drift Pin, Hammer**

Hit the injector body with the drift pin to loosen any rust.

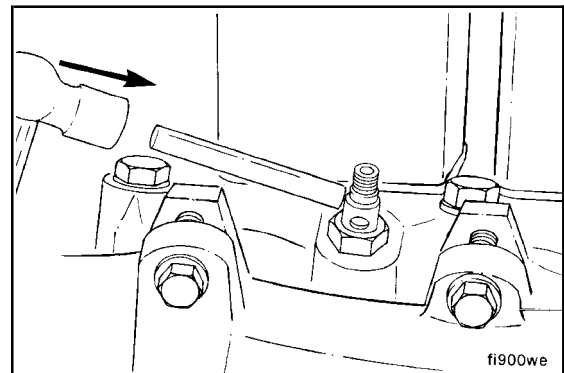

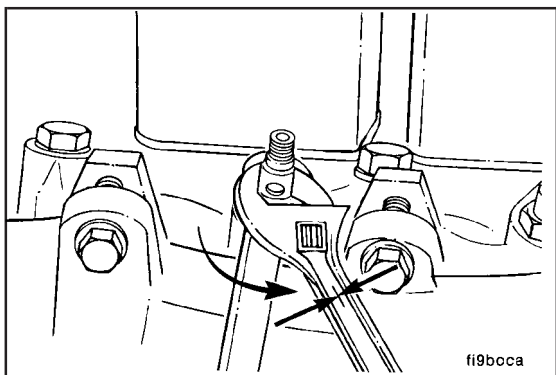

**24-mm Box Wrench, Adjustable Wrench**

Hold the injector body with an adjustable wrench while loosening the hold-down nut with a 24-mm box wrench.

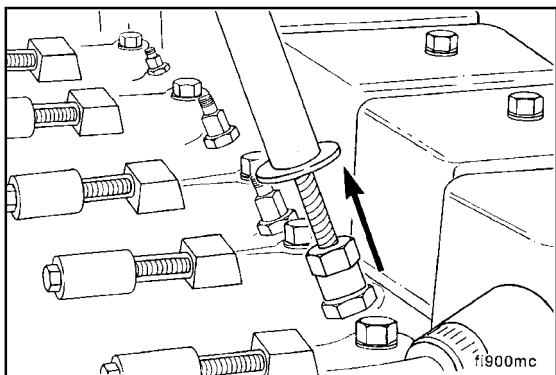

**Injector Puller, Part No. 3823276**

Remove the injectors. An injector puller is available for difficult-to-remove injectors.

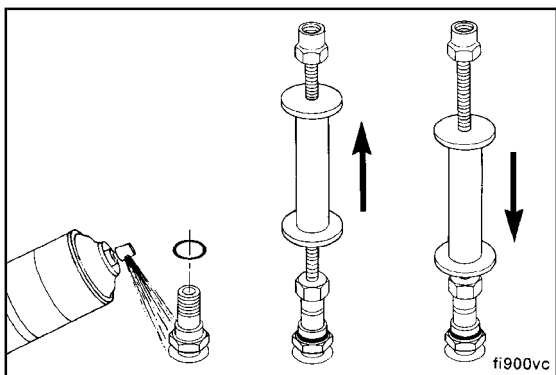

It is often necessary to tap the injector with the injector puller to work the injector up and down to remove it.

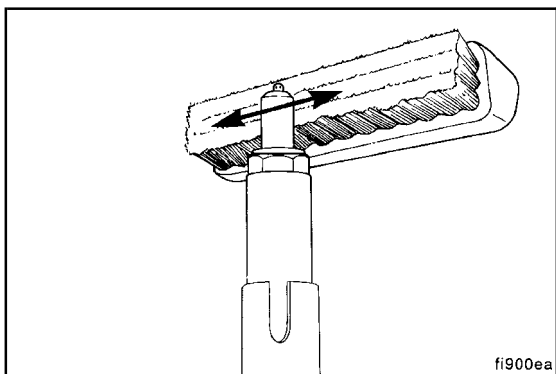

**Disassemble (006-026-003)**

Clean the carbon residue from the injector nozzle. Use a brass wire brush and a piece of hardwood dipped in test oil.

Remove the injector seal and discard.

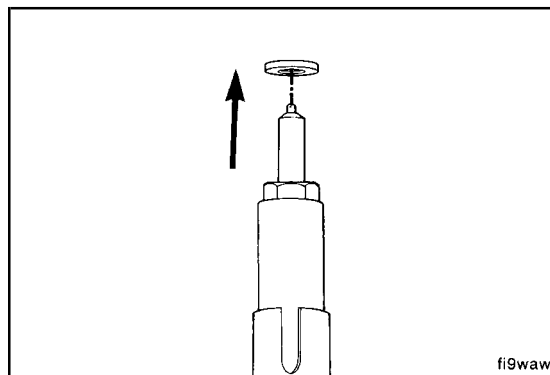

15 mm

Clamp an injector hold-down clamp in a soft-jawed vise to hold the injector.

Remove the injector nozzle retaining nut.

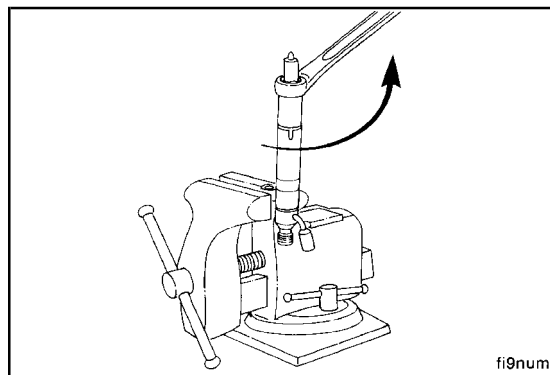

**▲ CAUTION ▲**

Place the injector nozzle and needle valve in a suitable bath of clean test oil or damage will occur.

Remove the nozzle needle valve and intermediate plate.

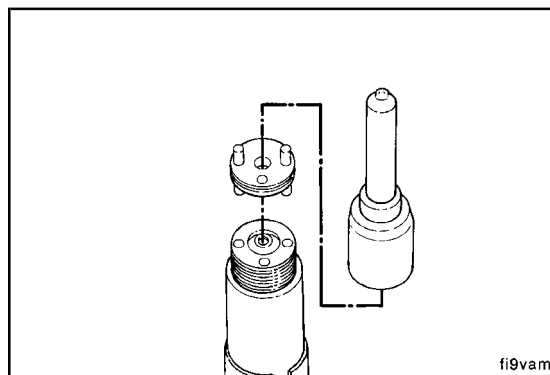

**▲ CAUTION ▲**

Hold the needle valve by the stem only. Contact from the skin will corrode the finely lapped surface.

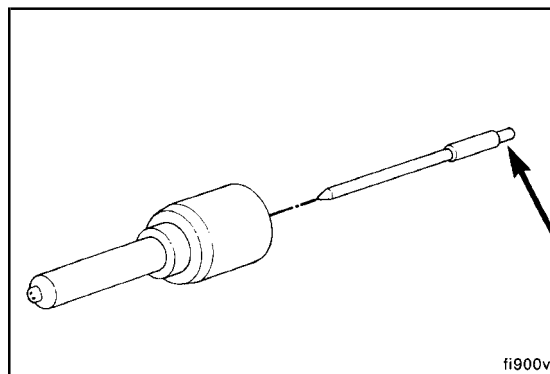

**NOTE:** The needle valve and nozzle tip are precisely matched for fit. The parts **must not** be intermixed.

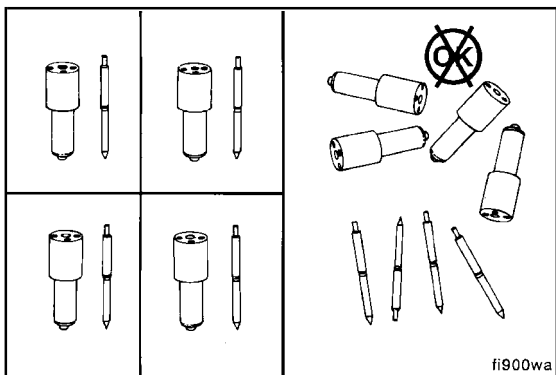

fi900wa

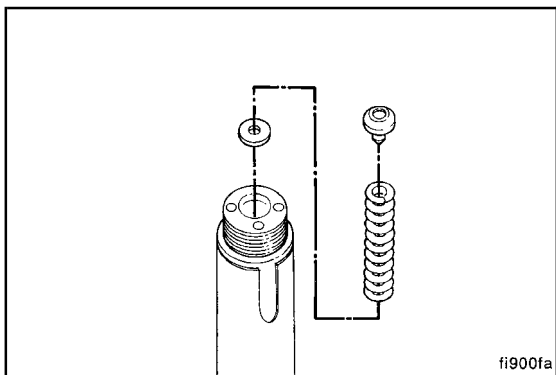

fi900fa



Remove the nozzle holder from the vise.  
Remove the pressure spindle, pressure spring, and shims.

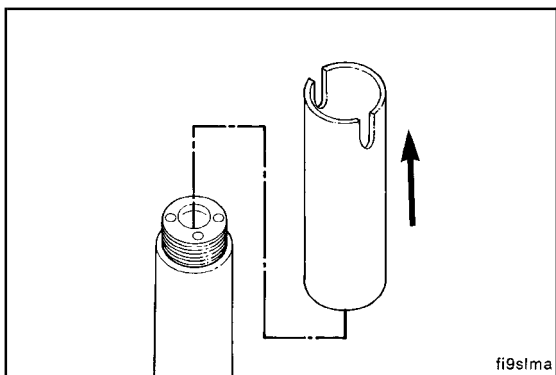

fi9slma



Remove and discard the injector sealing sleeve.

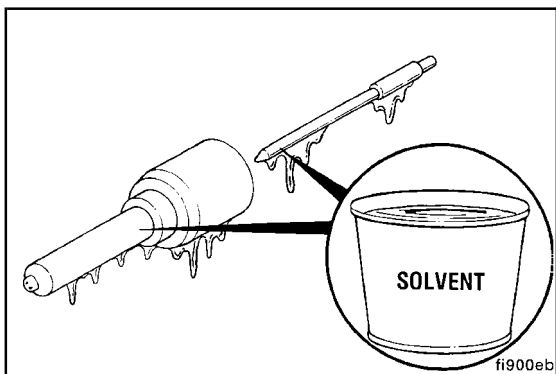

fi900eb



**Clean (006-026-006)**

**▲ WARNING ▲**

When using solvents, acids, or alkaline materials for cleaning, follow the manufacturer's recommendations for use. Wear goggles and protective clothing to avoid personal injury.

Rinse the nozzle bodies and needle valves in solvent to flush thoroughly and remove completely all varnish and carbon deposits.

**⚠ CAUTION ⚠**

Never use emery paper, a steel brush, or any other metal scraper to clean the nozzle. The parts can be damaged.

**Nozzle Cleaning Kit, Part No. 3376947**

Dip the nozzle seat in clean test oil, and use the nozzle cleaning kit, Part No. 3376947, to clean the nozzle seat. Polish the needle seat with a piece of hardwood dipped in test oil.

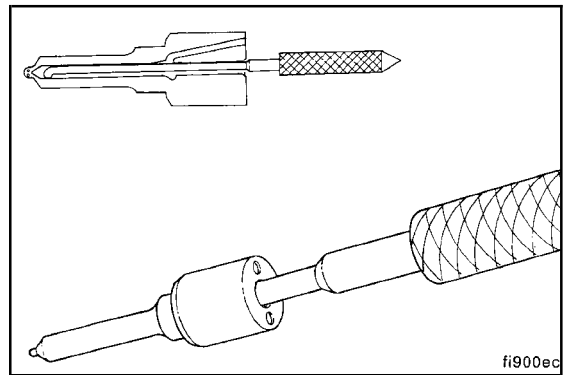

**⚠ WARNING ⚠**

When using solvents, acids, or alkaline materials for cleaning, follow the manufacturer's recommendations for use. Wear goggles and protective clothing to avoid personal injury.

**Nozzle Cleaning Kit, Part No. 3376947**

Clean the interior ring groove of the nozzle with a scraper (as shown). Rinse in solvent to remove all dirt and carbon residue, and dip in clean test oil.

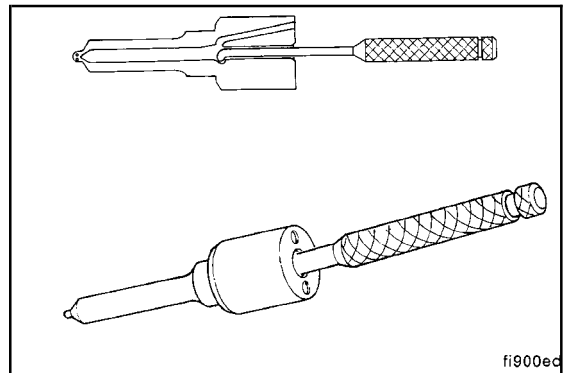

Clean the spray holes (as shown) with an appropriate-size cleaning needle.

Remove burned-on combustion deposits on all nozzles with a commercially available cleaner. Rinse all parts in clean test oil.

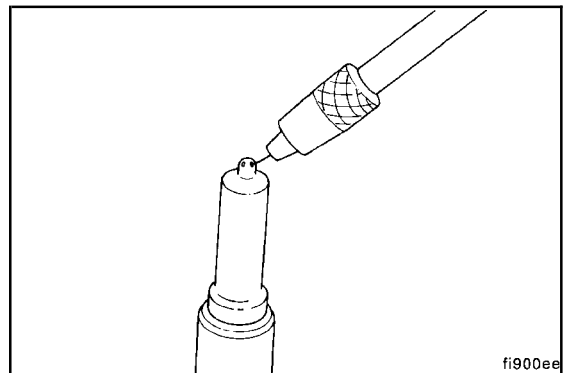

Clean the needle valve tip with a brass brush.

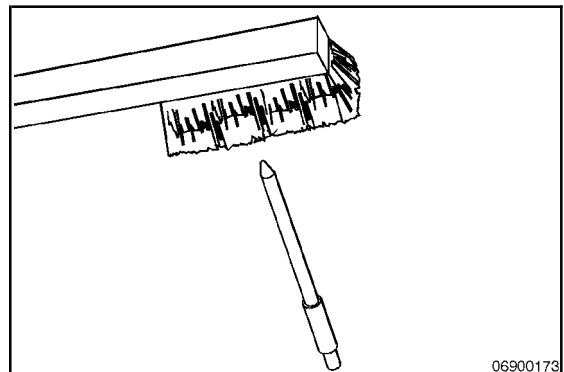

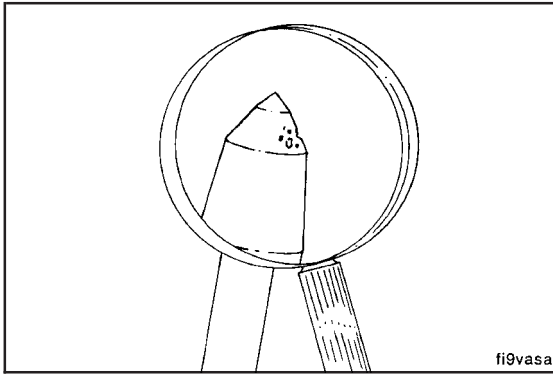

**Inspect for Reuse (006-026-007)**

Inspect the injector. Inspect the o-ring for damage. Inspect for burrs on the inlet to the injector. Check the nozzle holes for any signs of damage such as hole erosion or hole plugging. Also, check the nozzle color for signs of overheating. Overheating will cause the nozzle to turn a dark yellow and tan or blue color, depending on the temperature of the overheat.

Inspect for rough surfaces and erosion. The pressure shoulder will normally have a rough machined appearance.

Inspect the injector bore for old sealing washers.

**NOTE:** Deteriorated needle valves **must** be replaced as a matched unit with their compatible nozzle body.

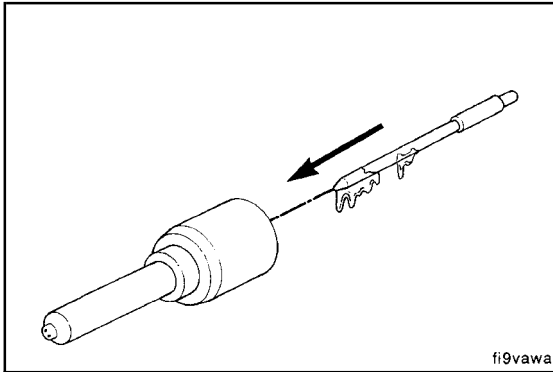

Dip the needle valve in clean test oil, and insert the needle valve all the way into the nozzle body.

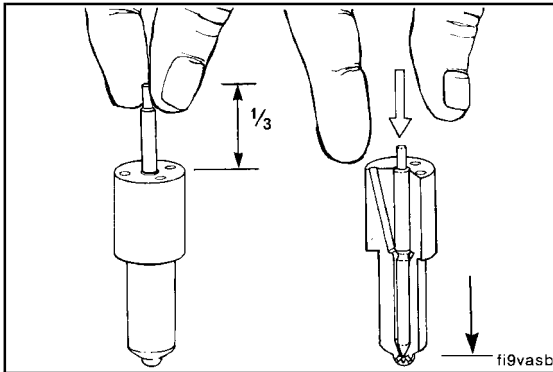

Pull the needle valve one-third of the way out of the nozzle body. With the needle valve in the vertical position, the needle valve **must** slide all the way back into the nozzle body under its own weight.

If the nozzle fails the slide test, clean and test the nozzle again.

**NOTE:** Any needle valve and nozzle body assembly that does **not** pass this test **must** be replaced.

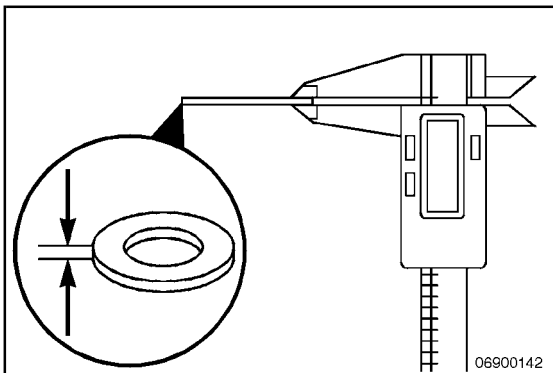

**Measure (006-026-010)**

Verify that the injector sealing washer is the correct thickness. The incorrect sealing washer can cause high-pressure fuel leaks and/or performance problems due to incorrect injector protrusion.

Shim thickness specification: 1.5 mm [0.06 in].

**Test (006-026-012)**

To find which cylinder is misfiring, operate the engine and loosen the fuel line nut at one injector, and listen for a change in engine speed.

**NOTE:** A drop in engine speed indicates the injector was delivering fuel to the cylinder.

**NOTE:** Be sure to tighten the fuel line nut before proceeding to the next injector.

Check each cylinder until the malfunctioning injector is found.

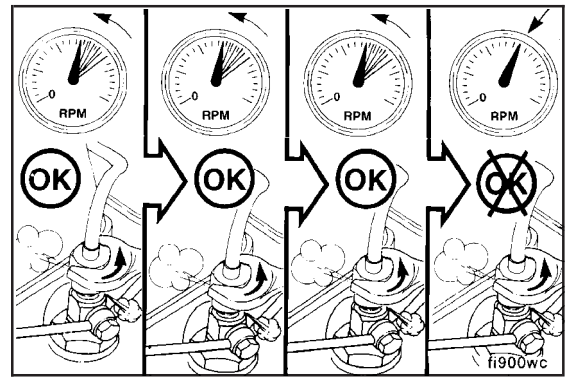

Remove the malfunctioning injector to test or replace it.

If the engine continues to misfire after replacing the injector, check for leaks in the high-pressure line. Also, check for a defective delivery valve that lets the fuel drain back into the injection pump.

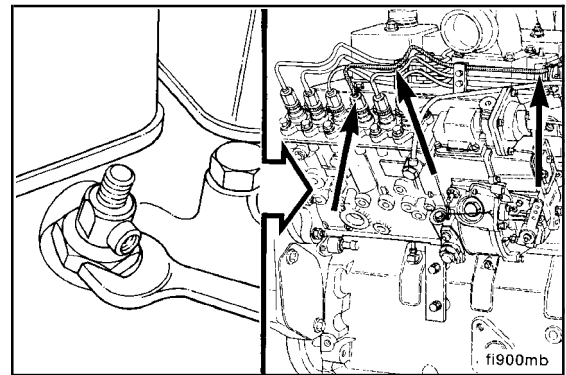

Check for an extra copper sealing washer on the injector.

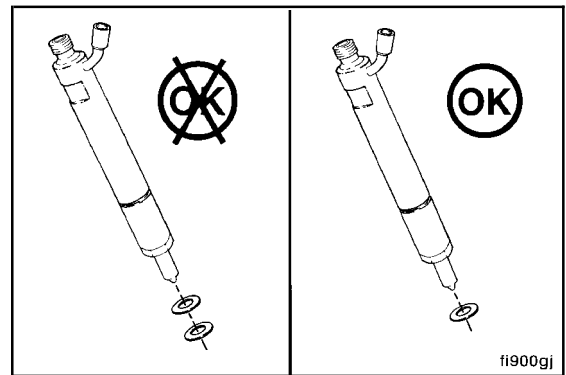

Carbon buildup in the orifices in the nozzle will also cause low power from the engine. Remove and check the spray pattern, or replace the injectors.

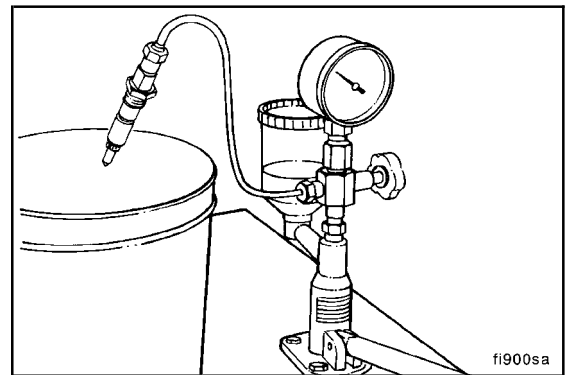

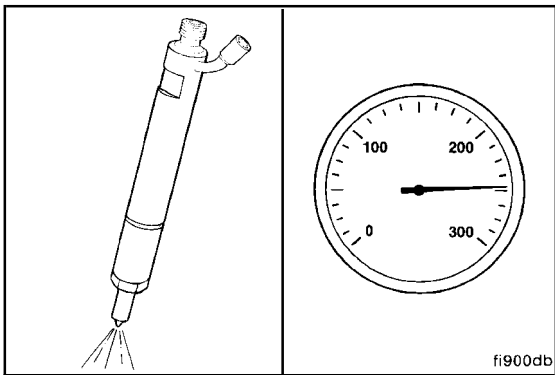

**▲ WARNING ▲**

While testing the injectors, keep hands and body parts away from the injector nozzle. Fuel coming from the injector is under extreme pressure and can cause serious injury by penetrating the skin.

Injector Nozzle Tester, Part No. 3376947

**NOTE:** All nozzles **must** be tested for opening pressure, chatter, and spray pattern.

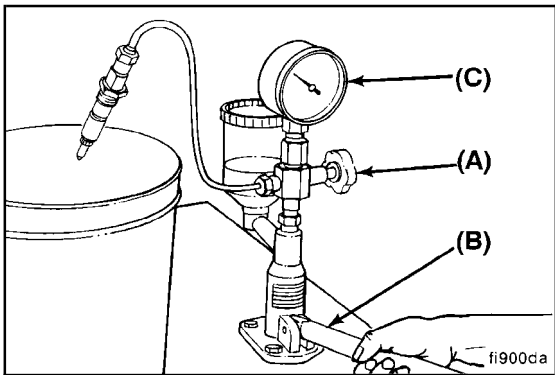

Check the injector opening pressure.



- A. Open the valve.
- B. Operate the lever at one stroke every second.
- C. Read the pressure indicated when the injector spray begins.

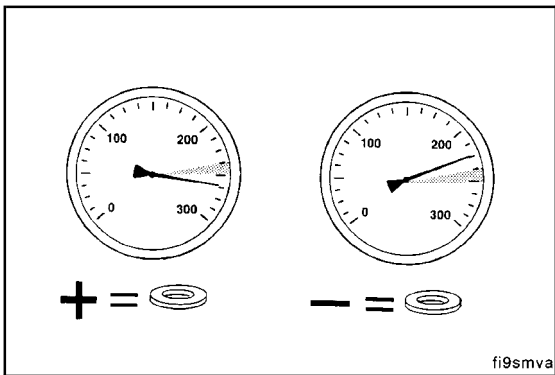

If the opening pressure does **not** meet specifications, try one of the following solutions:

1. Add shims to increase pressure.
2. Remove shims to decrease pressure.

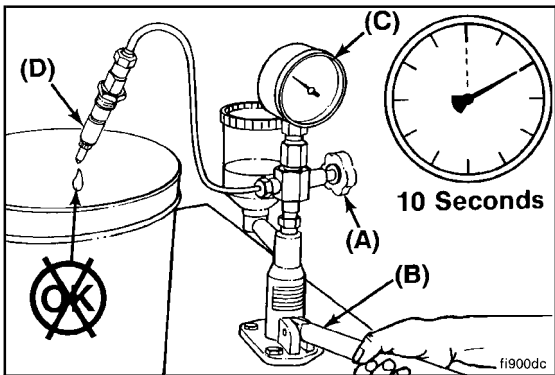

**Leakage Test**

1. Open the valve (A).
2. Operate the lever (B) to maintain a pressure of 20 bar [290 psi] below opening pressure (C).
3. No drops should fall from the tip (D) within 10 seconds.



**Chatter Test**

The chatter test indicates the ability of the needle valve to move freely and atomize the fuel correctly. An audible sound will possibly be heard as the valve rapidly opens and closes. A well-optimized spray pattern will possibly be seen.

**NOTE:** Used nozzles should **not** be evaluated for chatter at lower speeds. A used nozzle can generally be used if it passes the leakage test.

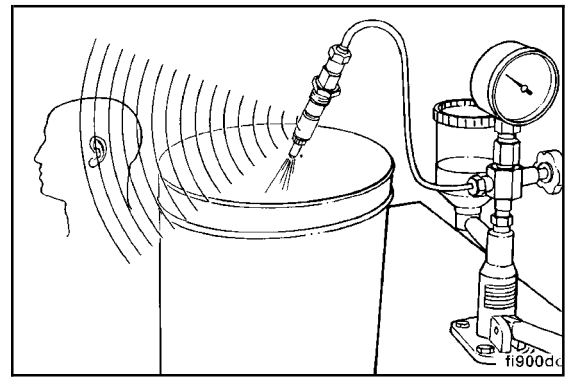

**Assemble (006-026-025)**



**When using solvents, acids, or alkaline materials for cleaning, follow the manufacturer's recommendations for use. Wear goggles and protective clothing to avoid personal injury.**

**NOTE:** Make sure that all mating surfaces and pressure faces are thoroughly cleaned and lubricated with test oil before assembly. New nozzles **must** be cleaned and lubricated before assembly.

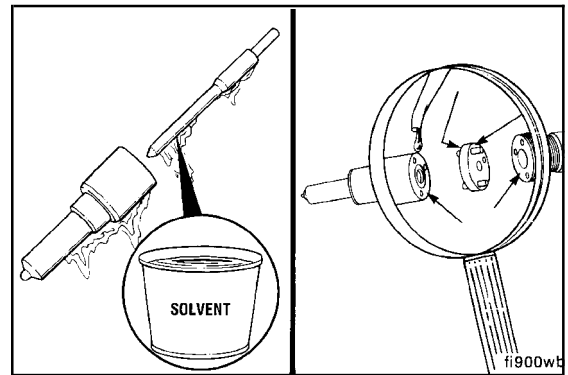

**NOTE:** Install the same thickness of shims that were removed in disassembly. Use the pressure spring to make sure that the shims are installed flat.

Install the shims and pressure spring.

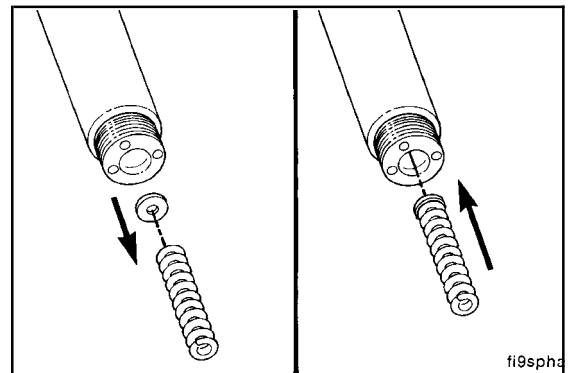

Install the spindle.

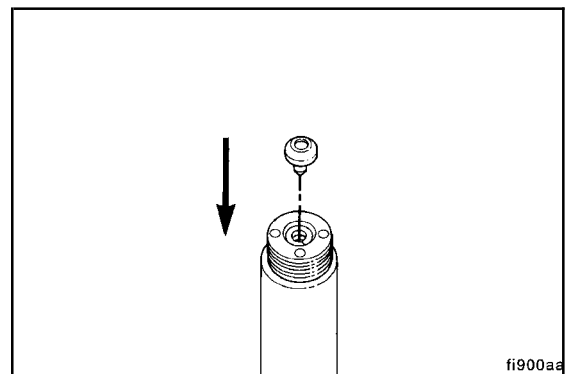

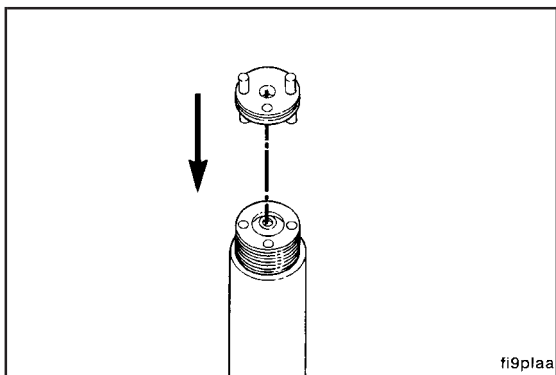

fi9plaa



Install the intermediate plate.

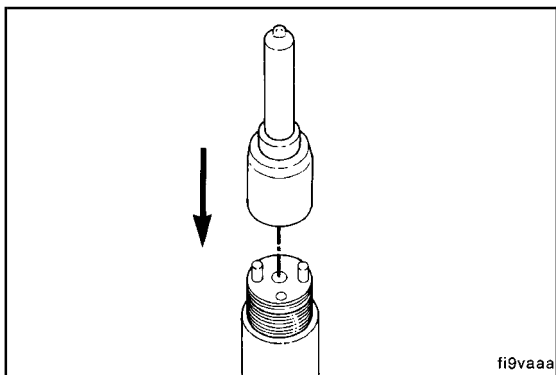

fi9vaaa



Install the needle valve and nozzle assembly.

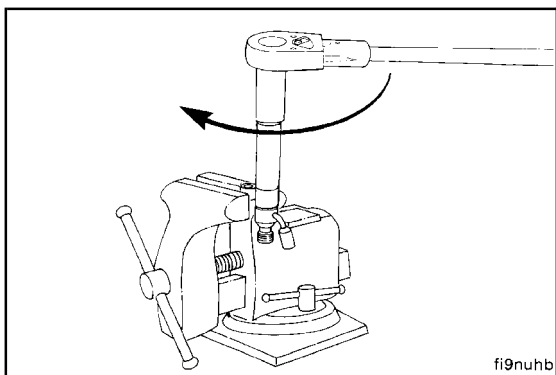

fi9nuhb



15 mm

Install the nozzle retaining nut.



**Torque Value:** 30 N•m [22 ft-lb]

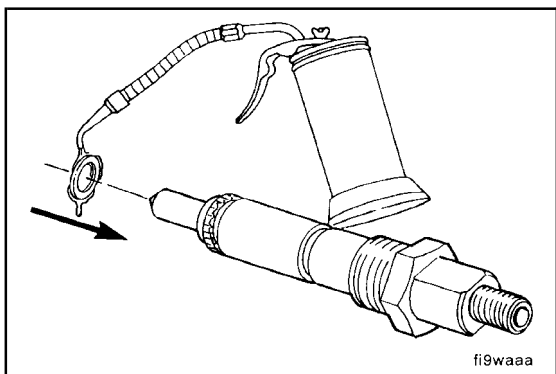

fi9waaa



**Install (006-026-026)**

Assemble the injector and new copper sealing washer.

Use **only** one copper washer.

**Service Tip:** A light coat of clean lubricating engine oil between the washer and injector can help to keep the washer from falling during installation.

**⚠ CAUTION ⚠**

Early model injectors (pre-1991) have a 9-mm injector tip that can not be used in engines built in 1991 or later as these engines use a 7-mm injector tip.

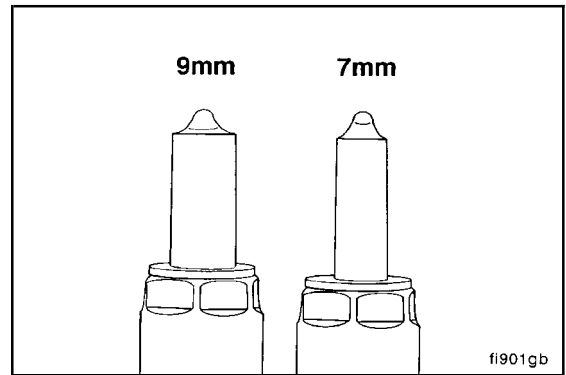

Seven mm injectors can be used in early model (9-mm) injector holes provided the special adapter sleeve is installed onto the 7-mm injector tip.

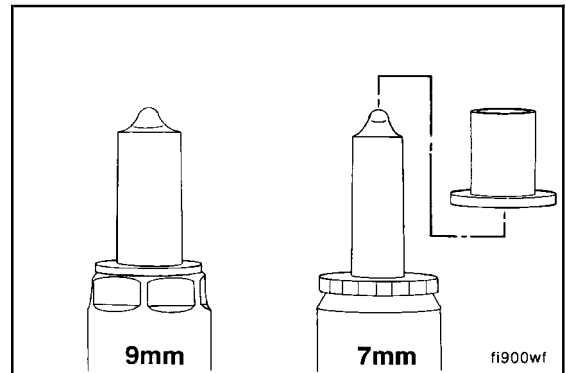

**Anti-seize Compound, Part No. 3824879**

Apply a coat of anti-seize compound, Part No. 3824879, to the threads of the injector hold-down nut and between the top of the nut and the injector body.

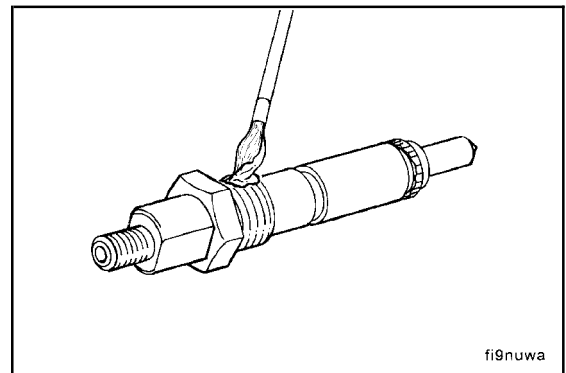

**24-mm Deep Well Socket**

**NOTE:** Align the injector's protrusion with the notch in the bore.

**NOTE:** The present Bosch® injector has an o-ring located above the hold down nut. After tightening the injector, be sure to push the o-ring into the groove.

**Torque Value:** 60 N•m [44 ft-lb]

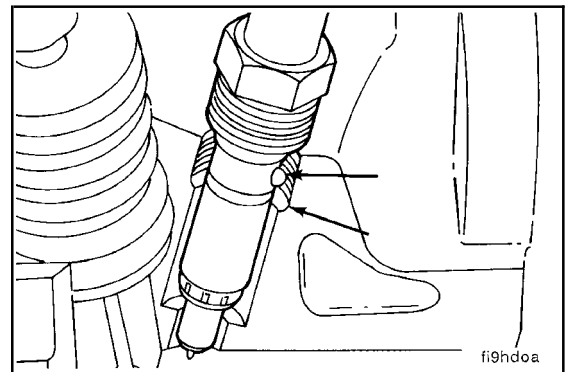

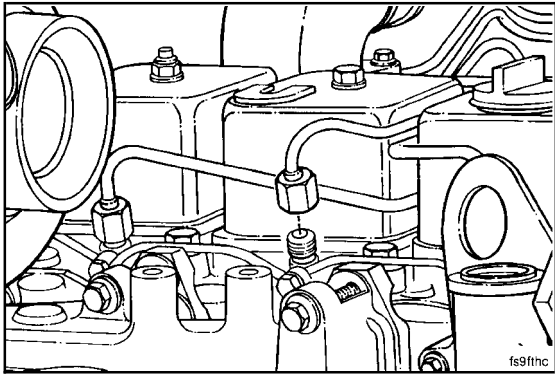

Assemble the fuel drain manifold and high-pressure lines. Leave the high-pressure fittings loose at the injectors.

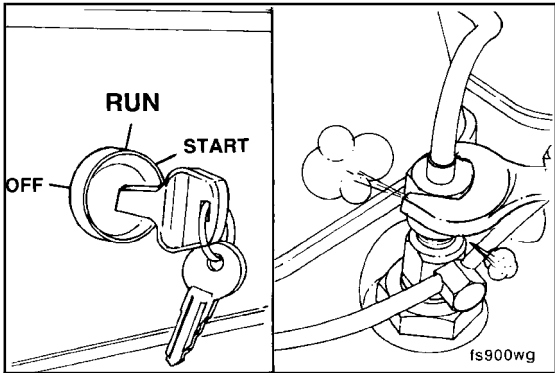

**▲ WARNING ▲**

It is necessary to turn the keyswitch to the ON position. Because the engine can start, be sure to follow all of the safety precautions. Use the normal engine starting procedure.

17 mm, 19 mm

Crank the engine to allow entrapped air to bleed from the lines.

Tighten the fittings.

**Torque Value:** 38 N•m [28 ft-lb]

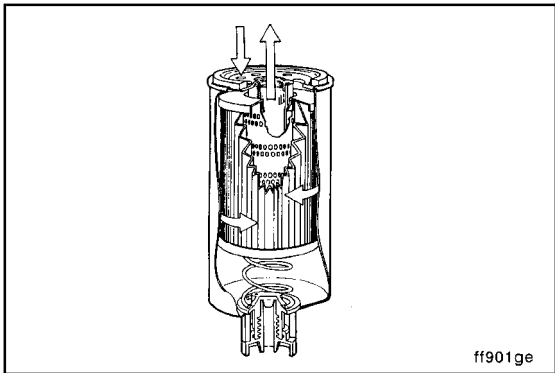

**Fuel-Water Separator (006-043)**

**General Information**

**▲ CAUTION ▲**

Some of the clearances between the fuel injection pump parts are very close. For this reason, the parts can easily be damaged by rust formation and contaminants.

**NOTE:** Be sure to use the correct element.

Filtration and separation of water from the fuel is important for trouble-free operation and long life of the fuel system.

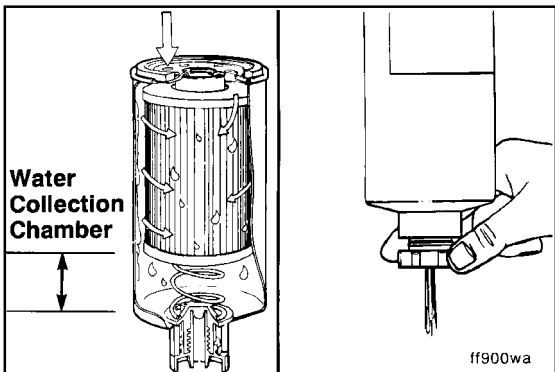

The element has a valve that can be opened regularly to drain the collected water.

**B3.9 and B5.9 Series Engines**  
**Section 6 - Injectors and Fuel Lines - Group 06**

A dual water separator/filter adapter provides additional filtering capacity. The fuel flows through the adapter to a larger combination fuel-water separator filter and back to the fuel filter for final filtering.

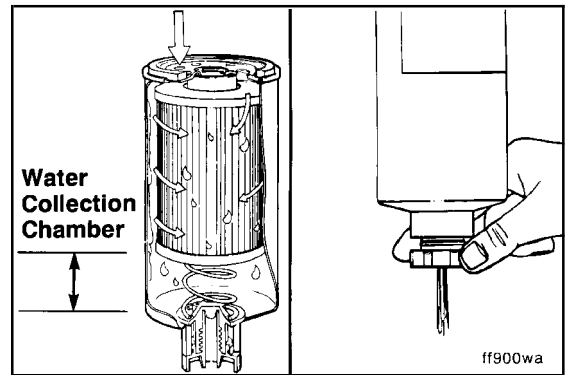

Regular maintenance, including draining moisture from the fuel-water separator/filter and supply tanks, is essential to keep water out of the fuel.

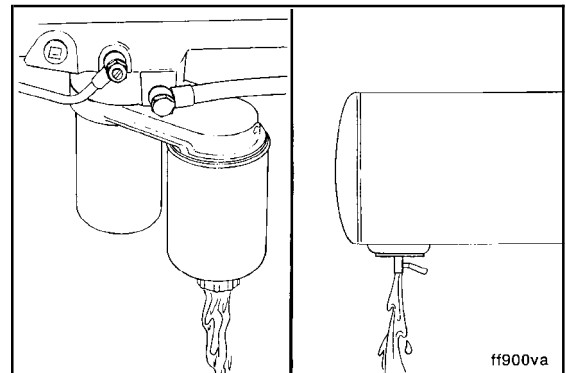

B Series engine model 1991 and newer equipped with a Bosch® P7100 in-line fuel injection pump have the fuel filter mounted at the rear of the intake manifold (as shown).

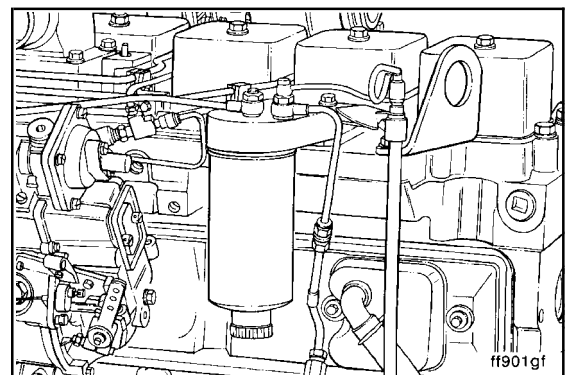

**Fuel Return Overflow Valve (006-044)**  
**Initial Check (006-044-001)**

**⚠ CAUTION ⚠**

**A sticky check ball or spring will result in engine low power.**

Use a small screwdriver to make sure that the check ball is **not** sticking in the high-pressure relief valve assembly.

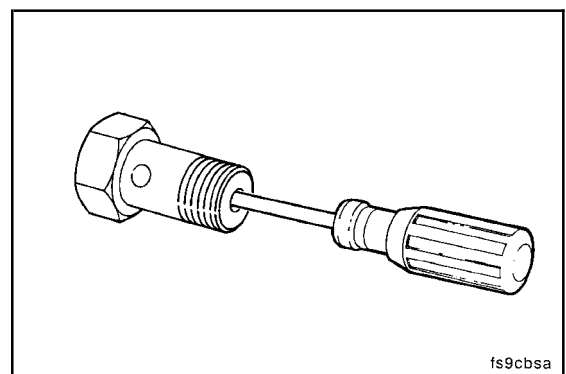

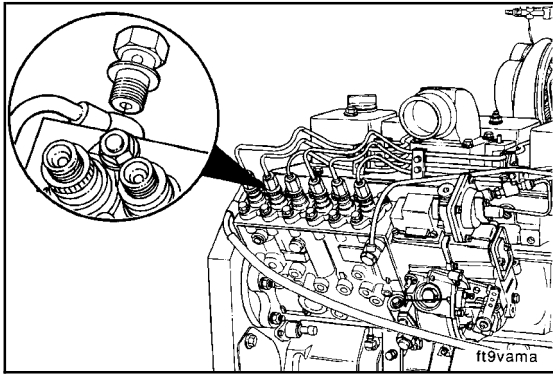

**Remove (006-044-002)**

19 mm



**Bosch® In-Line Pump**

Remove the pressure relief valve and sealing washer.

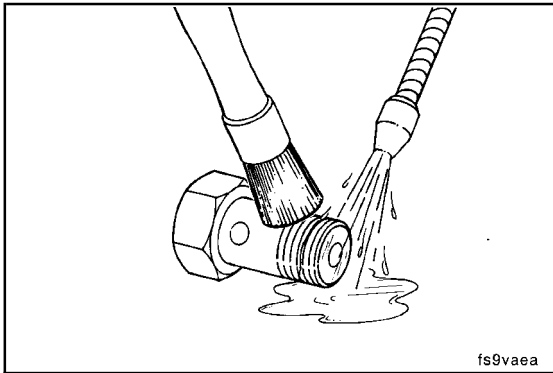

**Clean (006-044-006)**

**▲ WARNING ▲**

When using solvents, acids, or alkaline materials for cleaning, follow the manufacturer's recommendations for use. Wear goggles and protective clothing to avoid personal injury.

Thoroughly flush the high-pressure relief valve with cleaning solution.

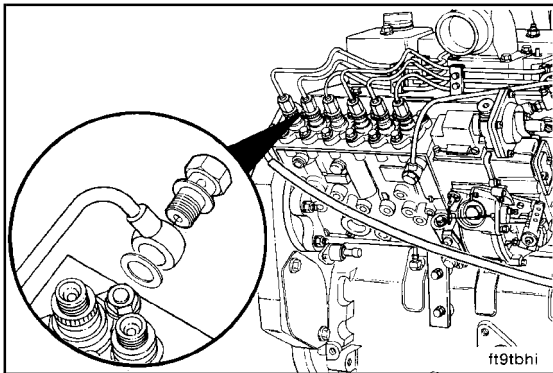

**Install (006-044-026)**

**▲ CAUTION ▲**

Do not use the center cap as a vent. This will cause damage to the overflow valve.



10 mm, 19 mm

Install the high-pressure relief valve assembly in the reverse order of removal.

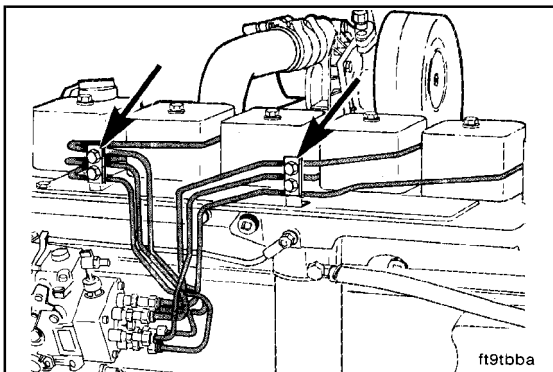

**Injector Supply Lines (High Pressure) (006-051)**

**General Information**

**▲ CAUTION ▲**

The high-pressure lines must be clamped securely and routed so they do not contact each other or any other components.

The high-pressure fuel lines are designed and manufactured to deliver fuel at injection pressure to the injectors. The high-pressure pulses will cause the lines to expand and contract during the injection cycle.

Shown here are the high-pressure fuel lines for the distributor-type injection pump.

Shown here are the high-pressure fuel lines for the Bosch® in-line injection pump.

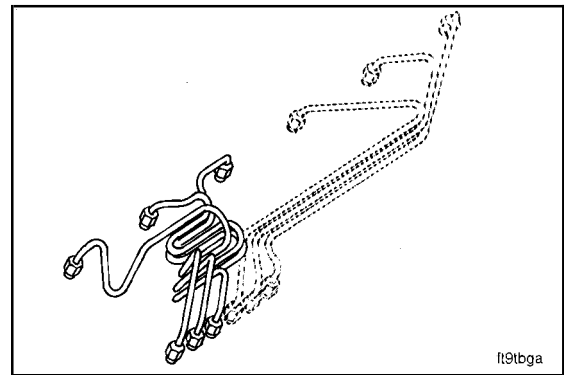

Do **not** weld or substitute lines; use **only** the specified part number for the engine.

The length, internal size, and rigidity of the lines are critical to smooth engine operation. An attached metal tag is used to identify each line with a part number.

A metal tag attached to each line identifies the line with a part number.

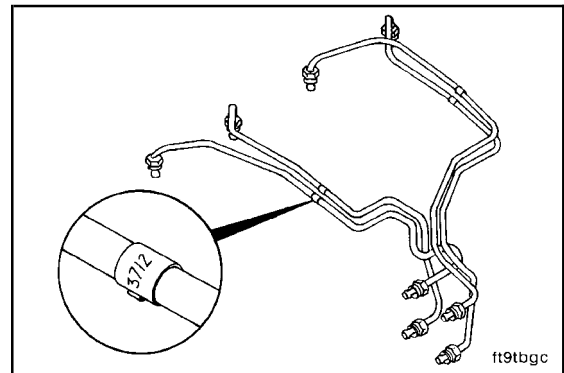

**▲ WARNING ▲**

**Keep hands and body parts away from the high-pressure fuel lines. Fuel coming from the high-pressure fuel lines is under extreme pressure and can cause serious injury by penetrating the skin.**

Use cardboard to check for cracks and leaks. With the engine running, move the cardboard over the fuel lines, and look for fuel spray on the cardboard. Fuel leaks can cause poor engine performance.

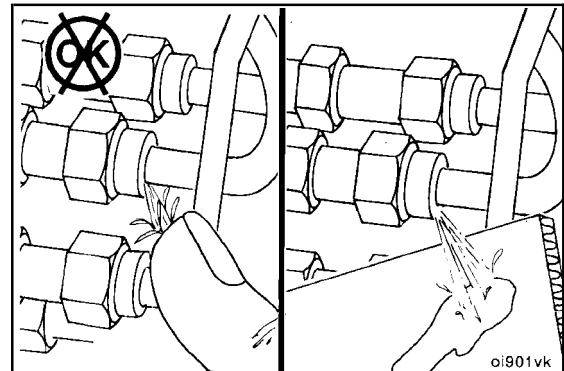

It is normal to have entrapped air in the fuel lines after replacing the pump or the lines. Air in the lines will cause the engine to run rough or produce a fuel knock.

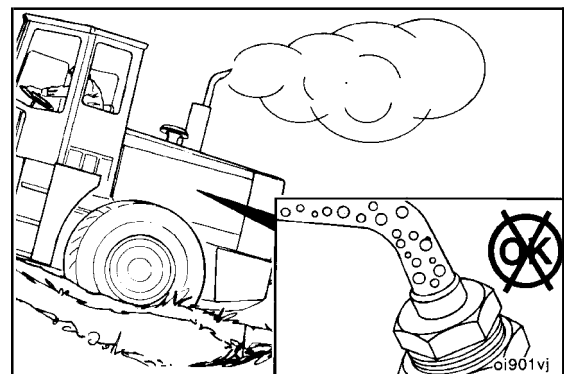

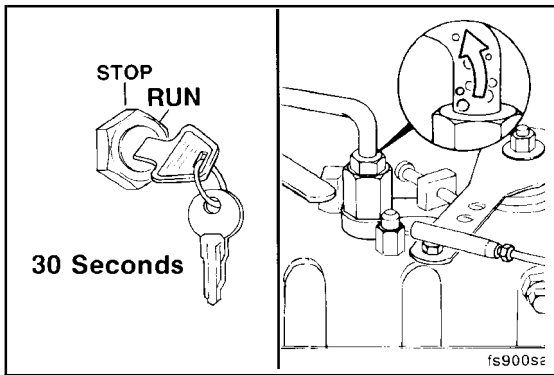

Bleed the air from the high-pressure line at the fitting that connects the injector. Bleed one line at a time until the engine runs smoothly.

If the air can **not** be removed, check the pump and supply line for suction leaks.

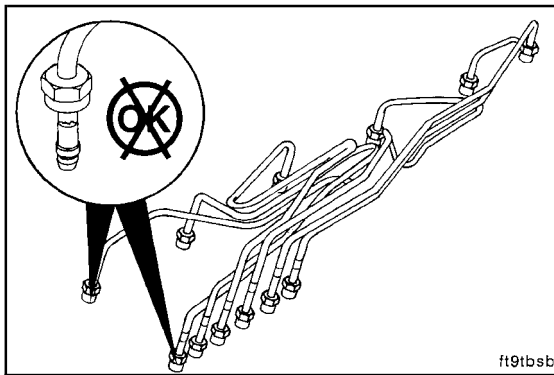

**Initial Check (006-051-001)**

17 mm, 19 mm



Inspect the lines for cracks, chafes, and leaks. Make sure that the lines are tightened to proper specification.

17 mm, Fuel Pump Connection



Torque Value: 24 N•m [18 ft-lb]

19 mm, Cylinder Head Connection

Torque Value: 38 N•m [28 ft-lb]

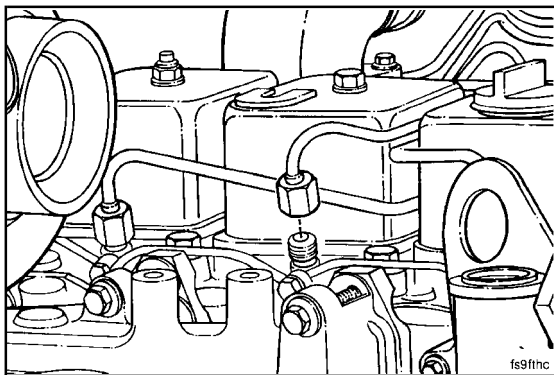

**Remove (006-051-002)**



When using solvents, acids, or alkaline materials for cleaning, follow the manufacturer's recommendations for use. Wear goggles and protective clothing to avoid personal injury.

17 mm

**Distributor-Type Pumps**

**NOTE:** Thoroughly clean the area around the fuel lines before removal.

Disconnect the high-pressure fuel lines from the injectors, and complete the following steps:

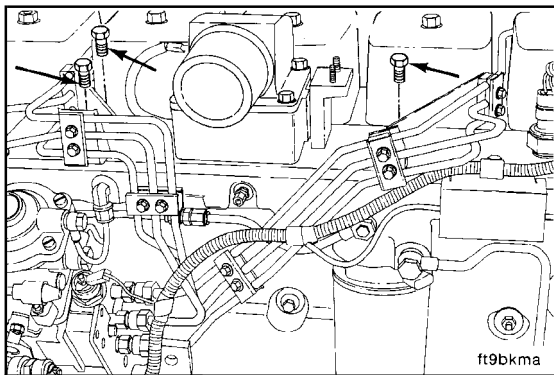

10 mm

Remove the fuel line clamp capscrews from the intake cover.





14 mm and 17 mm

Remove the fuel lines from the fuel injection pump.

**NOTE:** Use two wrenches to prevent the delivery valve holder from turning.

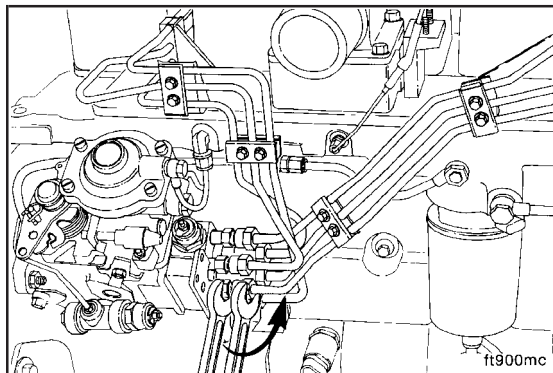

19 mm

In-Line Pump

**NOTE:** If individual fuel lines are to be replaced, remove the support clamp from the set of fuel lines containing the line to be replaced.

Disconnect the fuel line(s) from the injectors.

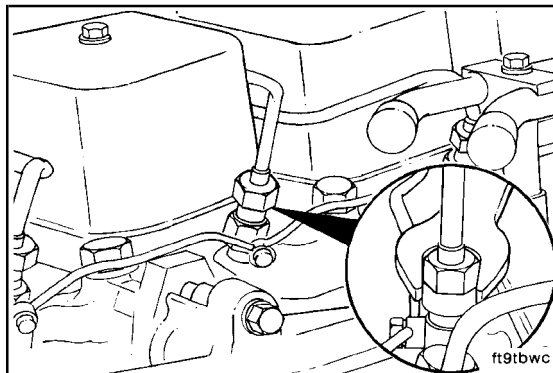

10 mm

Remove the fuel line clamp capscrews from the intake cover.

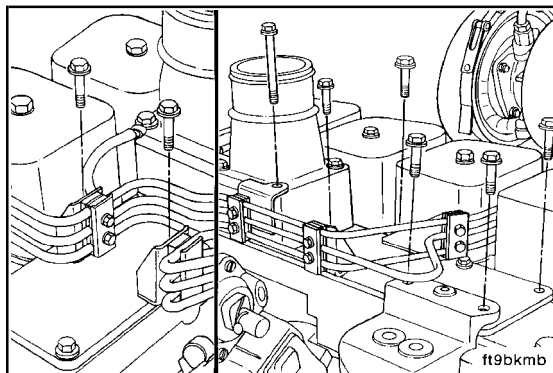

19 mm

Disconnect the fuel line(s) from the fuel injection pump.

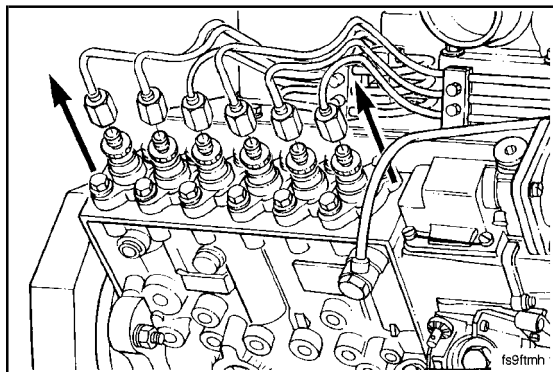

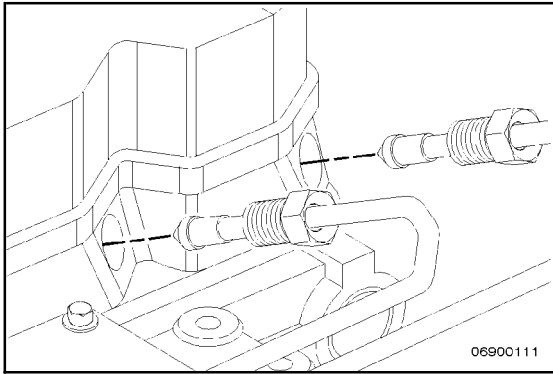

19 mm

Disconnect the high-pressure fuel lines from the cylinder head.

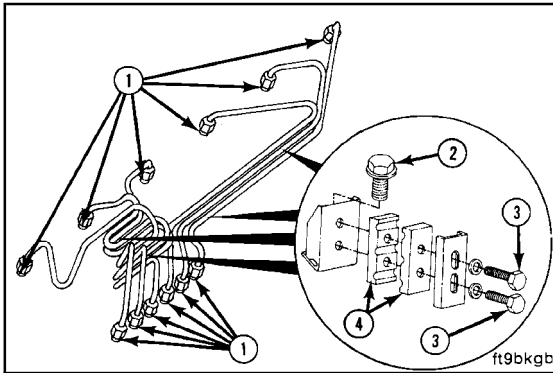

Remove fuel line fittings (1), support bracket capscrews (2), vibration capscrew isolator (3), and isolators (4).

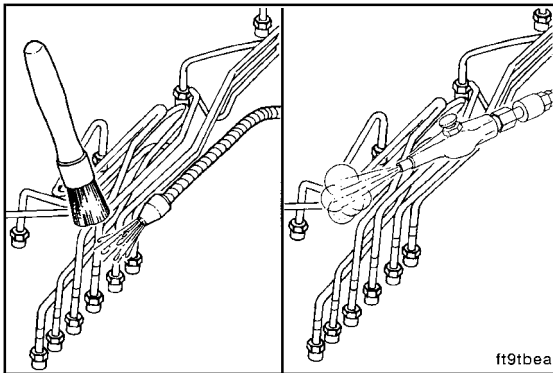

**Clean (006-051-006)**

**▲ WARNING ▲**

When using solvents, acids, or alkaline materials for cleaning, follow the manufacturer's recommendations for use. Wear goggles and protective clothing to avoid personal injury.

**▲ WARNING ▲**

Wear appropriate eye and face protection when using compressed air. Flying debris and dirt can cause bodily injury.

**NOTE:** Make sure that all paint chips are removed.

Wash the fuel lines in clean solvent.

Dry with compressed air.

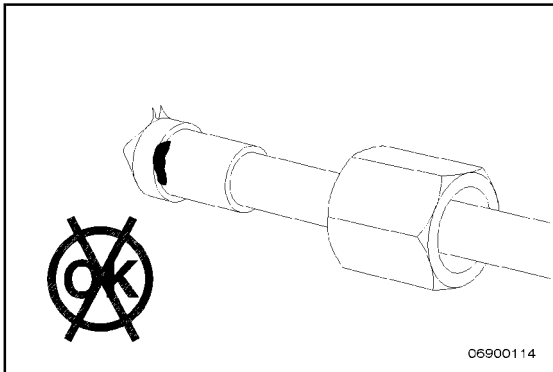

**Inspect for Reuse (006-051-007)**

Inspect the ferrules of the lines for any signs of burrs or foreign material.

**Install (006-051-026)**

17 mm, 19 mm

Install the fuel lines in reverse order of removal.

**17 mm, Fuel Pump Connection**

**Torque Value:** 24 N•m [18 ft-lb]

**19 mm, Cylinder Head Connection**

**Torque Value:** 38 N•m [28 ft-lb]

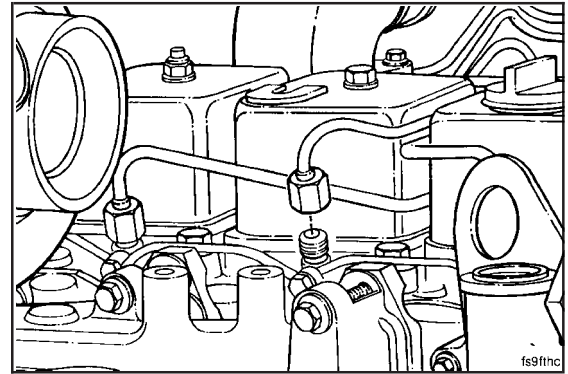



## Section 7 - Lubricating Oil System - Group 07

### Section Contents

	Page
<b>Engine Oil Heater</b> .....	7-8
Install .....	7-8
Preparatory .....	7-8
Remove.....	7-8
<b>Flow Diagram, Lubricating Oil System</b> .....	7-3
<b>Lubricating Oil Contamination</b> .....	7-31
General Information .....	7-31
<b>Lubricating Oil Cooler</b> .....	7-8
Clean.....	7-10
Install.....	7-10
Preparatory .....	7-8
Pressure Test.....	7-10
Remove.....	7-9
<b>Lubricating Oil Dipstick</b> .....	7-11
Calibrate .....	7-11
<b>Lubricating Oil Dipstick Tube</b> .....	7-12
Install .....	7-12
Remove.....	7-12
<b>Lubricating Oil Filter (Spin-On)</b> .....	7-13
Install .....	7-13
Remove.....	7-13
<b>Lubricating Oil Level</b> .....	7-30
Initial Check .....	7-30
<b>Lubricating Oil Pan</b> .....	7-14
Clean .....	7-16
Drain .....	7-15
Fill .....	7-18
General Information .....	7-14
Inspect for Reuse .....	7-17
Install .....	7-17
Remove.....	7-16
<b>Lubricating Oil Pressure Regulator (Main Rifle)</b> .....	7-19
Clean .....	7-20
Inspect for Reuse .....	7-20
Install .....	7-21
Preparatory.....	7-19
Remove.....	7-19
<b>Lubricating Oil Pressure Sensor, OEM</b> .....	7-41
Inspect for Reuse .....	7-41
Install.....	7-41
Remove .....	7-41
<b>Lubricating Oil Pump</b> .....	7-21
Inspect for Reuse .....	7-22
Install .....	7-25
Preparatory.....	7-21
Remove .....	7-21
<b>Lubricating Oil Suction Tube (Block-Mounted)</b> .....	7-28
Clean .....	7-29
Fill.....	7-30
Inspect for Reuse .....	7-29
Install .....	7-29
Preparatory.....	7-28
Remove.....	7-28
<b>Lubricating Oil System - General Information</b> .....	7-2
<b>Lubricating Oil System Diagnostics</b> .....	7-36

	<b>Page</b>
General Information .....	7-36
<b>Service Tools</b> .....	7-1
Lubricating Oil System .....	7-1
<b>Specifications</b> .....	7-6
Lubricating Oil System .....	7-6

## Service Tools

### Lubricating Oil System

The following special tools are recommended to perform procedures in this section. The use of these tools is shown in the appropriate procedure. These tools can be purchased from your local Cummins Authorized Repair Location.

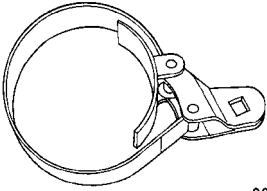
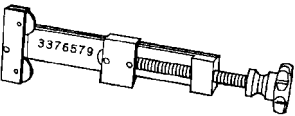
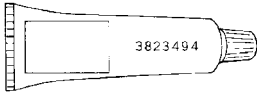
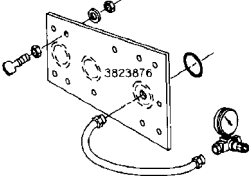
Tool No.	Tool Description	Tool Illustration
3375049	<p><b>Oil Filter Wrench</b></p> <p>Used to install and/or remove the large spin-on lubricating oil or fuel filters.</p>	 <p style="text-align: right;">3375049</p>
3376579	<p><b>Tube (Filter) Cutter</b></p> <p>Used to cut open the filter to permit inspection of the filter element.</p>	 <p style="text-align: right;">3376579</p>
3823494	<p><b>Three-Bond™ Sealant</b></p> <p>Used to seal lubricating oil pan and gasket.</p>	 <p style="text-align: right;">3823494</p>
3823876	<p><b>Lubricating Oil Cooler Pressure Test Kit</b></p> <p>Used to seal and pressurize the lubricating oil cooler to test for leaks.</p>	

## Lubricating Oil System - General Information

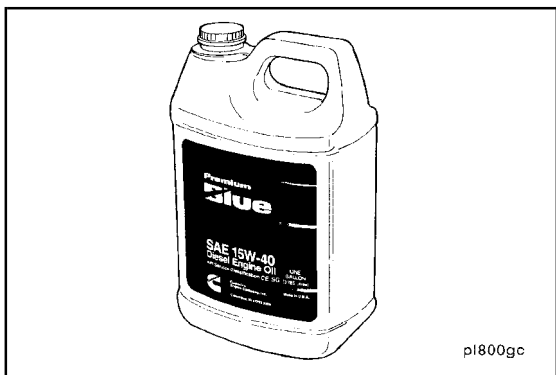

**▲ WARNING ▲**

Some state and federal agencies have determined that used engine oil can be carcinogenic and cause reproductive toxicity. Avoid inhalation of vapors, ingestion, and prolonged contact with used engine oil.

**▲ WARNING ▲**

To avoid personal injury, avoid direct contact of hot oil with your skin.

Cummins Engine Company, Inc., recommends the use of a high-quality SAE-40 heavy-duty engine oil, such as Cummins Premium Blue®, which meets the American Petroleum Institute (API) performance classification CF/SG.

**▲ CAUTION ▲**

Limited use of low-viscosity lubricating oils, such as 10W-30, can aid in starting the engine and providing sufficient lubricating oil flow at ambient temperatures below -5°C [23°F]. However, the continuous use of low-viscosity lubricating oils can decrease engine life. Refer to the accompanying chart.

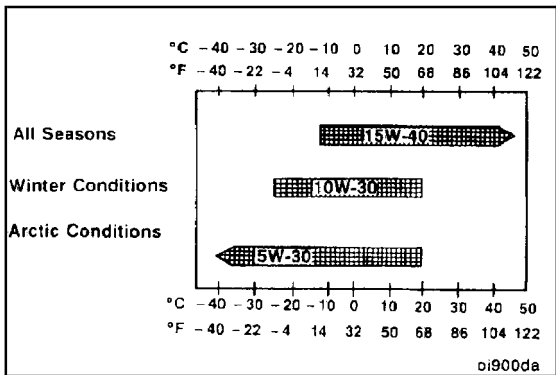



## Flow Diagram, Lubricating Oil System

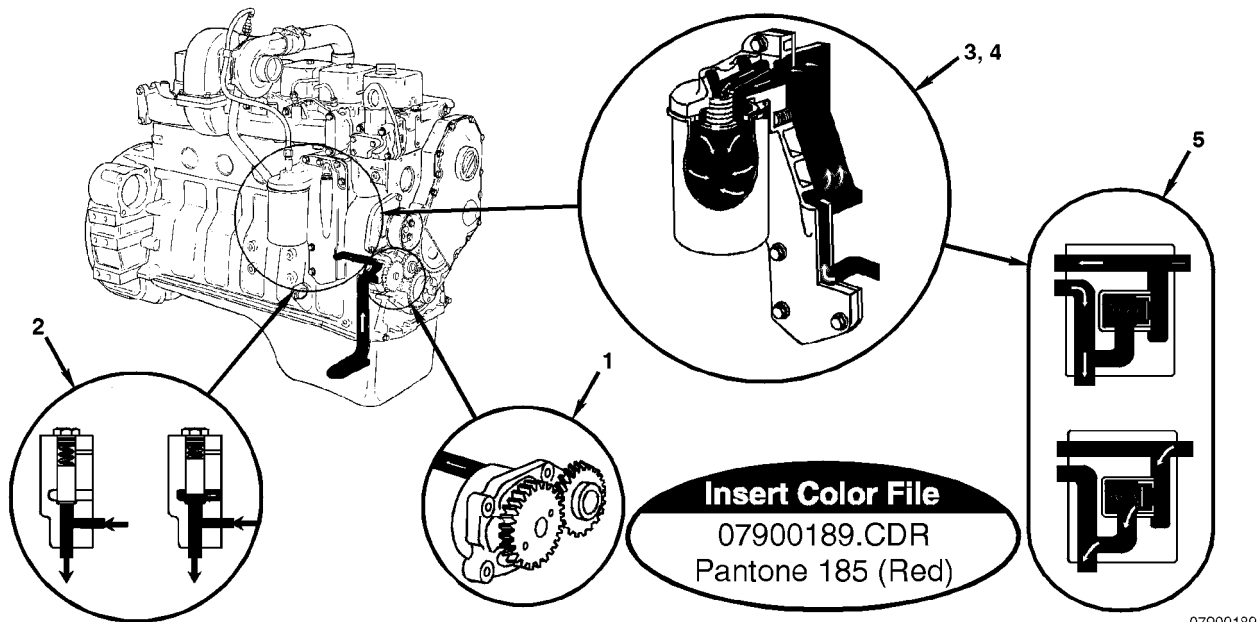

- |                                 |                         |
|---------------------------------|-------------------------|
| 1. Gerotor lubricating oil pump | 4. Full-flow filter     |
| 2. Pressure-regulating valve    | 5. Filter bypass valve. |
| 3. Lubricating oil cooler       |                         |

**Lubricating Oil Pump**

The engine uses a gerotor-type lubricating oil pump (1). The machined cavity in the block is the same for all engines. A wider gerotor is used in the six-cylinder engine to increase the lubricating pump capacity. Consequently, the four-cylinder and six-cylinder lubricating pumps are **not** interchangeable.

**Pressure-Regulating Valve**

The pressure-regulating valve (2) is designed to keep the lubricating oil pressure from exceeding 449 kPa [65 psi]. When the lubricating oil pressure from the pump is greater than 449 kPa [65 psi], the valve opens, uncovering the dump port, so part of the lubricating oil is routed to the oil pan. The minimum lubricating oil pressure limit is the same for the four-cylinder and the six-cylinder engine. Because of manufacturing tolerances of the components and the oil passages, the lubricating oil pressure can differ as much as 69 kPa [10 psi] between engines.

Lubrication for the Turbocharger

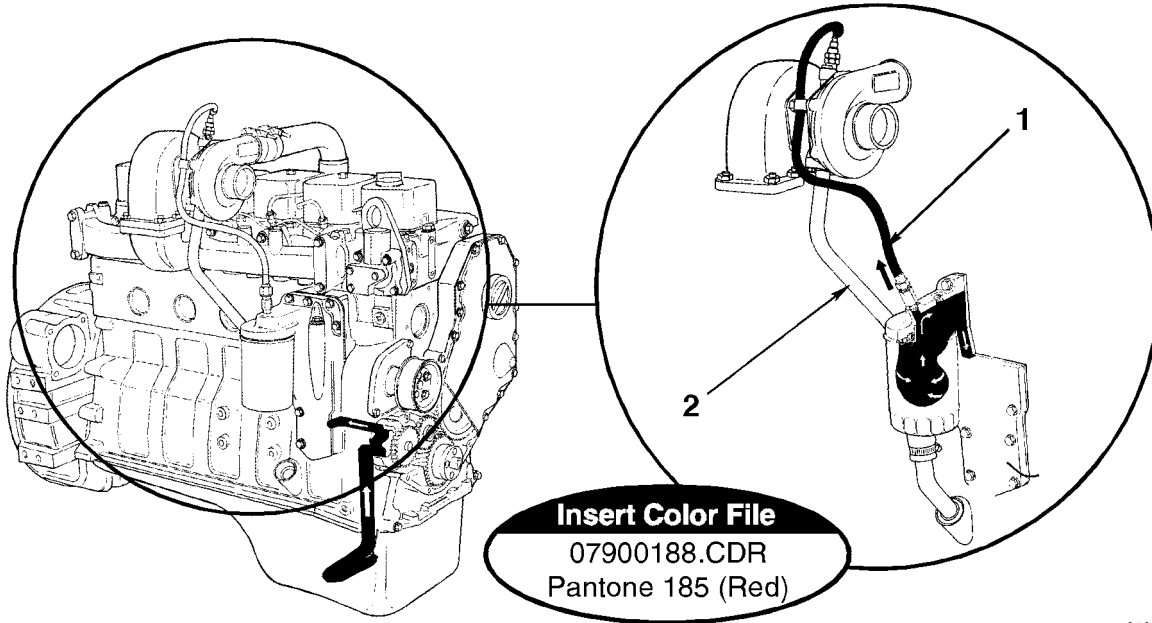

1. Oil supply
2. Oil drain.

The turbocharger receives filtered, cooled, and pressurized lubricating oil through a supply line from the filter head. A drain line connected to the bottom of the turbocharger housing returns the lubricating oil to the lubricating oil pan through a fitting in the cylinder block.

Lubrication for the Power Components

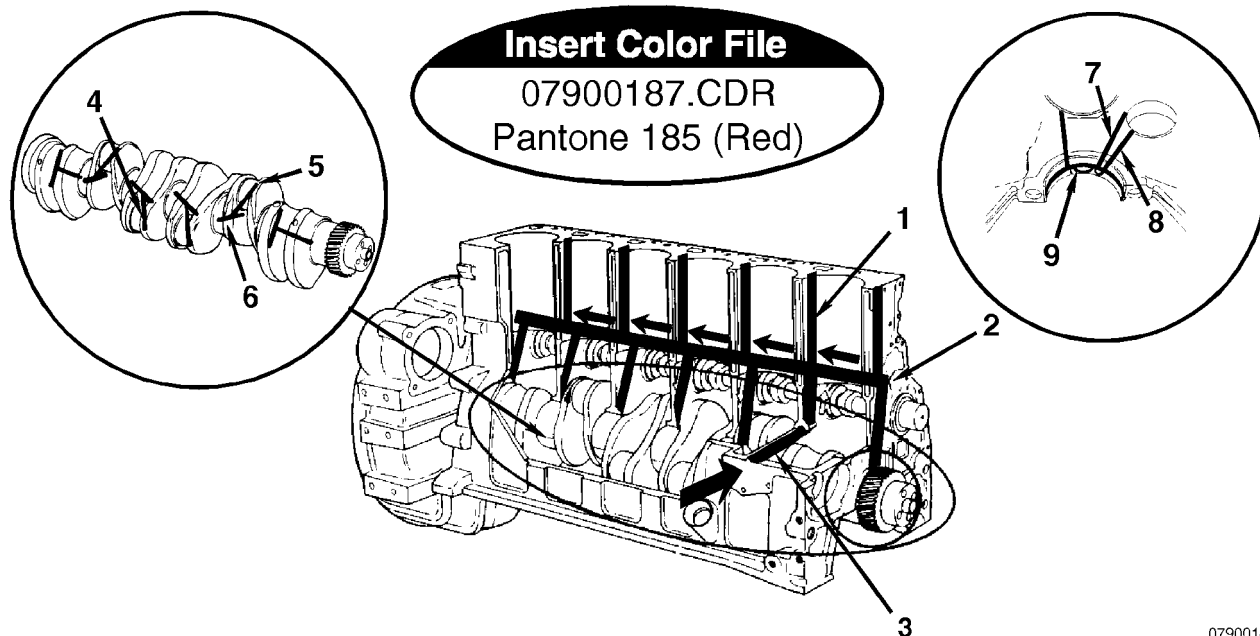

07900187

- |                    |                              |
|--------------------|------------------------------|
| 1. To valve train  | 6. Crankshaft, main journal  |
| 2. Main oil rifle  | 7. From main oil rifle       |
| 3. From oil cooler | 8. To camshaft               |
| 4. Rod journal     | 9. To piston cooling nozzle. |
| 5. To rod bearing  |                              |

The main bearings and the valve train are lubricated by pressurized oil directly from the main oil rifle. The other power components, connecting rods, pistons, and camshaft receive pressurized oil indirectly from the main oil rifle.

The drillings in the crankshaft supply oil to the connecting rod bearings. The oil is supplied to the camshaft journals through drillings in the main bearing saddle. Smaller drillings in the main bearing saddle supply oil to the piston cooling nozzles. The spray from the nozzles also provides lubrication for the piston pins.

The No. 1 main bearing saddle does **not** contain a piston cooling nozzle. Cylinder No. 1 receives the lubricating and cooling spray from the nozzle located in the No. 2 bearing saddle. Cylinder No. 2 receives the spray from the No. 3 bearing saddle, etc.

Lubrication for the valve train is supplied through separate drillings in the cylinder block. The oil flows through the drillings and across the oil transfer slot in the cylinder head gasket. From the transfer slot, the oil flows around the outside diameter at the cylinder head capscrew, across a slot in the bottom of the rocker lever support, and up a vertical drilling in the support. From these drillings, oil flows through drillings in the rocker lever shaft to lubricate the rocker levers. Oil flows through a drilling in the rocker levers to fill a channel cast into the top of the levers. The oil from the channel lubricates the valve stems, push tubes, and tappets.

## Specifications

### Lubricating Oil System

#### Lubrication System Data (automotive)

	B3.9	B5.9
Lubricating Oil Pressure at Idle - (minimum allowable)	69 kPa [10 psi]	69 kPa [10 psi]
Lubricating Oil Pressure at Rated - (minimum allowable)	207 kPa [30 psi]	207 kPa [30 psi]
Regulating Valve Opening Pressure	449 kPa [65 psi]	449 kPa [65 psi]
Lubricating Oil Capacity:		
Standard Pan <b>Only</b>	9.5 liters [10 qt]	14.2 liters [15 qt]
Total System - Liters [U.S. qt]	11 liters [11.6 qt]	16.4 liters [17.3 qt]
Low to High	0.9 liter [1 qt]	1.9 liters [2 qt]

**4B Lubrication System Data (nonautomotive)**

	<b>4B3.9</b>	<b>4BT3.9</b>	<b>4BTA3.9</b>
Lubricating Oil Pressure at Idle - (minimum allowable)	69 kPa [10 psi]	69 kPa [10 psi]	69 kPa [10 psi]
Lubricating Oil Pressure at Rated - (minimum allowable)	207 kPa [30 psi]	207 kPa [30 psi]	207 kPa [30 psi]
Regulating Valve Opening Pressure	449 kPa [65 psi]	449 kPa [65 psi]	449 kPa [65 psi]
Lubricating Oil Capacity: Standard Pan <b>Only</b>	9.5 liters [10 qt]	9.5 liters [10 qt]	9.5 liters [10 qt]
Total System	10.9 liters [11.5 qt]	11 liters [11.6 qt]	11 liters [11.6 qt]
Low to High	0.9 liter [1 qt]	0.9 liter [1 qt]	0.9 liter [1 qt]

**6B Lubrication System Data (nonautomotive)**

	<b>6B5.9</b>	<b>6BT5.9</b>	<b>6BTA5.9</b>
Lubricating Oil Pressure at Idle - (minimum allowable)	69 kPa [10 psi]	69 kPa [10 psi]	69 kPa [10 psi]
Lubricating Oil Pressure at Rated - (minimum allowable)	207 kPa [30 psi]	207 kPa [30 psi]	207 kPa [30 psi]
Regulating Valve Opening Pressure	449 kPa [65 psi]	449 kPa [65 psi]	449 kPa [65 psi]
Lubricating Oil Capacity: Standard Pan <b>Only</b>	14.2 liters [15 qt]	14.2 liters [15 qt]	14.2 liters [15 qt]
Total System	16.3 liters [17.2 qt]	16.4 liters [17.3 qt]	16.4 liters [17.3 qt]
Low to High	1.9 liters [2 qt]	1.9 liters [2 qt]	1.9 liters [2 qt]

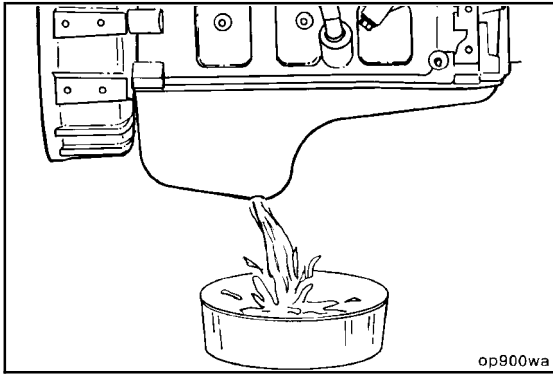

## Engine Oil Heater (007-001)

### Preparatory (007-001-000)



**WARNING**

Some state and federal agencies have determined that used engine oil can be carcinogenic and cause reproductive toxicity. Avoid inhalation of vapors, ingestion, and prolonged contact with used engine oil.



**WARNING**

To avoid personal injury, avoid direct contact of hot oil with your skin.

- Drain the lubricating oil. Refer to Procedure 007-025.

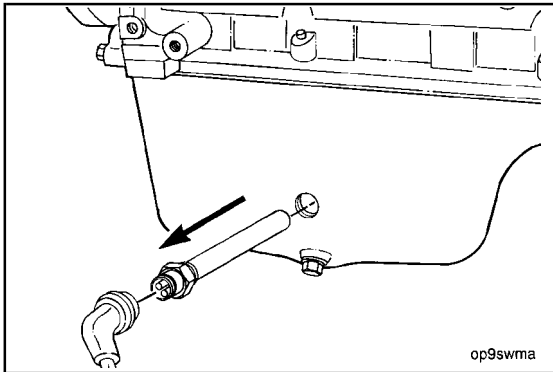

### Remove (007-001-002)

Disconnect the oil heater electrical cord.  
Remove the heater element.

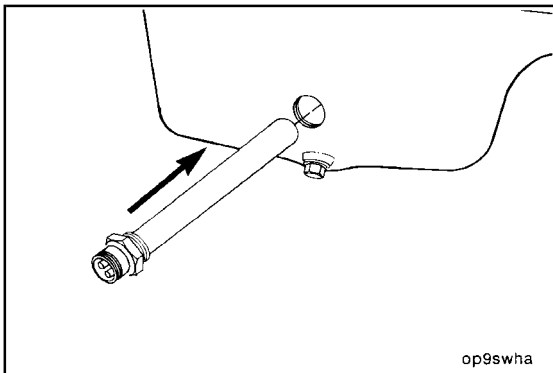

### Install (007-001-026)

**Ratchet, 1-Inch Deep Well Socket**

Replace the heater element.



Fill the engine with clean lubricating engine oil. Refer to Procedure 007-025.



Check for proper oil level.

Connect oil heater electrical cord.



**Torque Value:** 80 N•m [59 ft-lb]

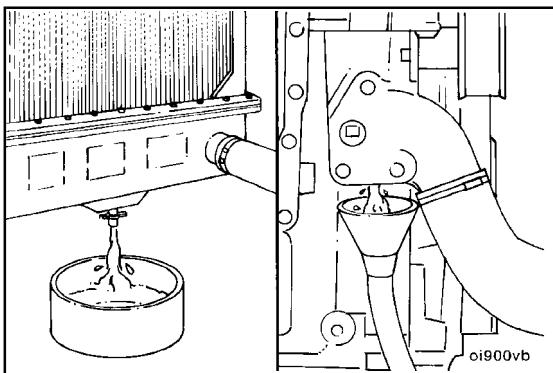

## Lubricating Oil Cooler (007-003)

### Preparatory (007-003-000)

- Drain the coolant. Refer to Procedure 008-018.

**Remove (007-003-002)**

Clean around the lubricating oil cooler cover.

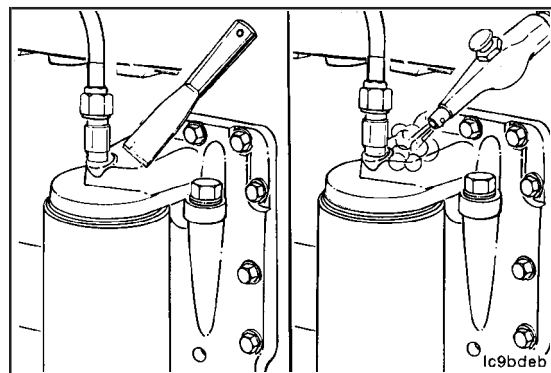

lc9bdeb

**Oil Filter Wrench, Part No. 3375049**

Remove the lubricating oil filter.

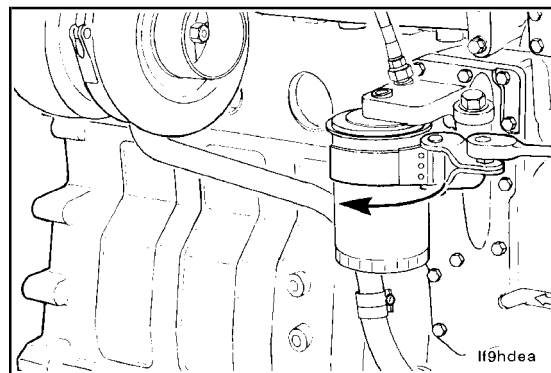

ll9hdea

**16 mm, 19 mm**

Disconnect the turbocharger supply line.

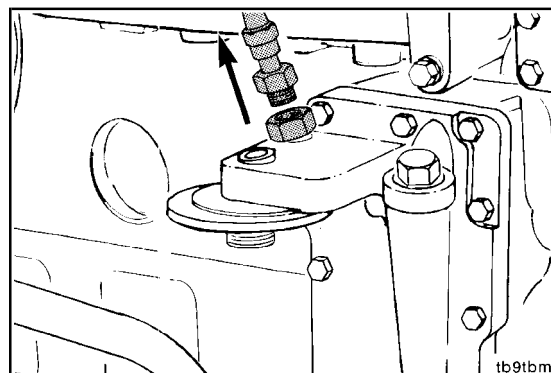

tb9tbmc

**10 mm**

Remove the lubricating oil cooler cover, gaskets, and cooler element.

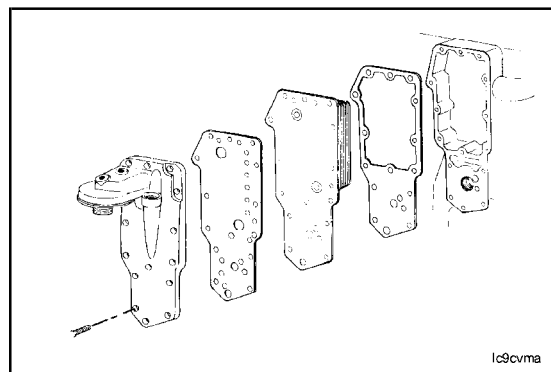

lc9cvma

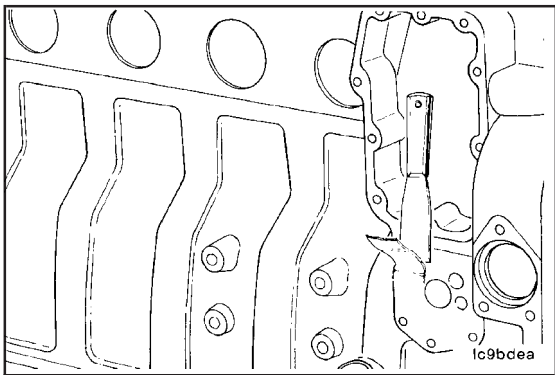

**Clean (007-003-006)**

Clean the sealing surfaces.

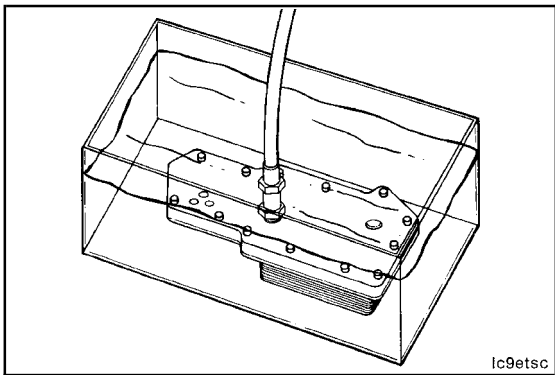

**Pressure Test (007-003-013)**

Pressure-test the element to check for leaks. If leaks are detected, replace the element.

Air Pressure Test		
kPa		psi
449	MIN	65
518	MAX	75

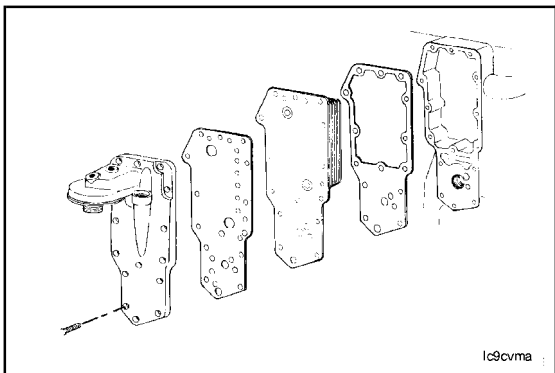

**Install (007-003-026)**

Assemble the lubricating oil cooler gaskets, element, and cover.



**Torque Value:** 24 N•m [18 ft-lb]

**NOTE:** Be sure to remove the shipping plugs from the element.

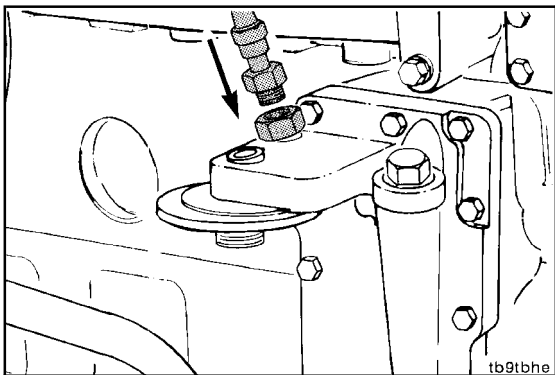

16 mm, 19 mm

Connect the turbocharger lubricating oil supply line.





**B3.9 and B5.9 Series Engines  
Section 7 - Lubricating Oil System - Group 07**

Fill the filter with clean lubricating oil, and apply a light coat of oil to the sealing gasket. Refer to the Operation and Maintenance Manual, B Series Engines, Bulletin No. 3810205, for lubricating oil recommendation.

Install the lubricating oil filter.

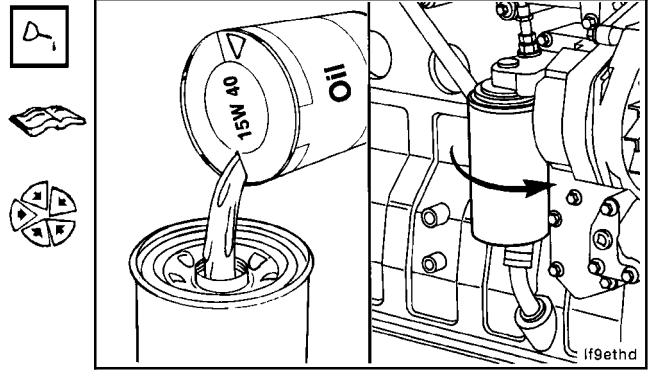

Fill the coolant system, and operate the engine to check for leaks.

Stop the engine, and check the coolant and lubricating oil level.

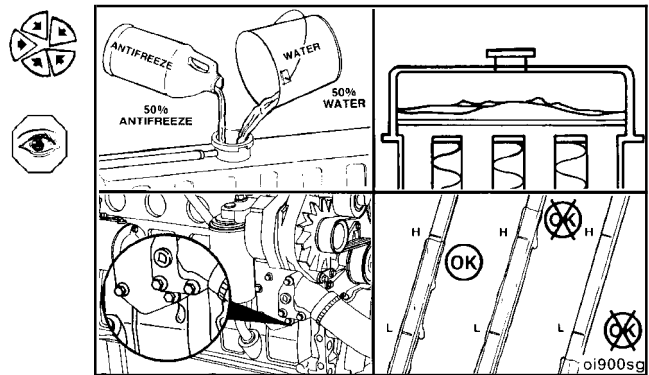

**Lubricating Oil Dipstick (007-009)**

**Calibrate (007-009-030)**

**NOTE:** This procedure **must** begin with the oil pan drained. Refer to Procedure 007-025.

Install the dipstick in the dipstick tube housing.

Use clean lubricating engine oil to fill the oil pan to the specified "low" oil level. Refer to Lubricating Oil System - Specifications in this section for the correct engine oil capacity.

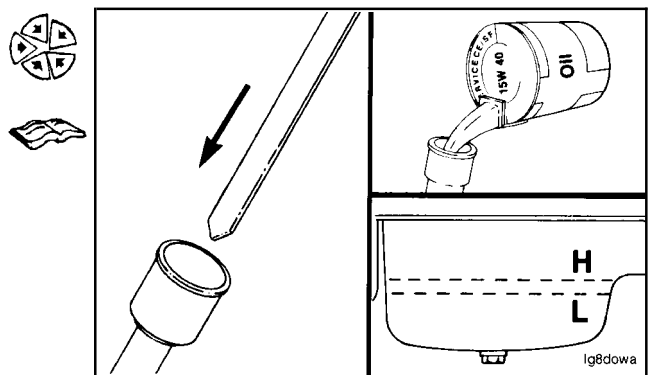

**⚠ CAUTION ⚠**

**Use care when marking the dipstick, or the dipstick will break if the scribe mark is too deep.**

Remove the dipstick and scribe a mark across the stick at the oil level. Label the mark with an "L" to indicate the "low" oil level.

**NOTE:** If a new blank dipstick is being used, cut the dipstick off approximately 38 mm [1.5 in] below the "low" oil level mark.

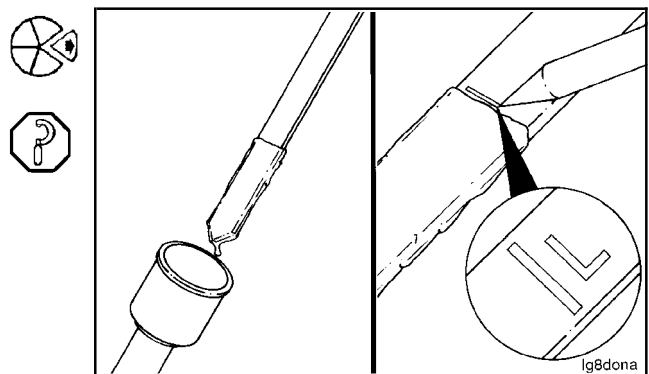

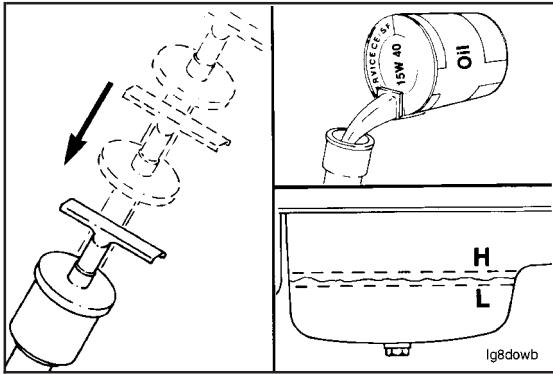

Wipe off the dipstick, and install it in the dipstick tube housing.



Fill the oil pan to the specified "high" oil level. Refer to Lubricating Oil System Specifications in this section for engine oil capacity.

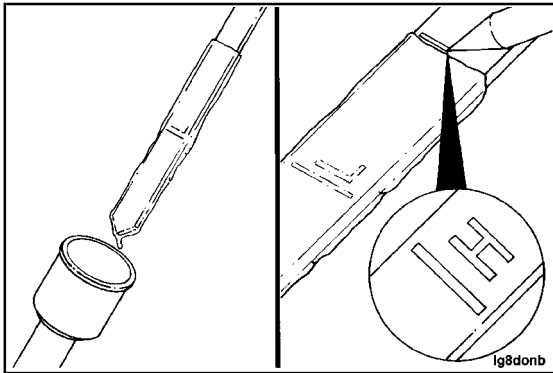

Remove the dipstick, and scribe a mark across the stick at the oil level. Label the mark with an "H" to indicate the "high" oil level.

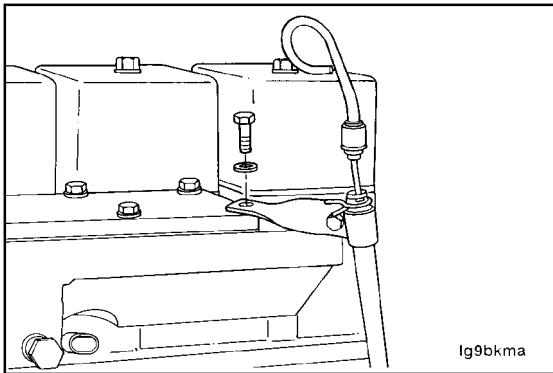

**Lubricating Oil Dipstick Tube (007-011)**

**Remove (007-011-002)**

Remove dipstick from the dipstick tube.

Remove dipstick tube from the cylinder block.

**Service Tip:** Use a dent puller and an M8 x 1.25 x 21-mm self-tapping capscrew. Thread the capscrew into the dipstick tube, and remove the tube.

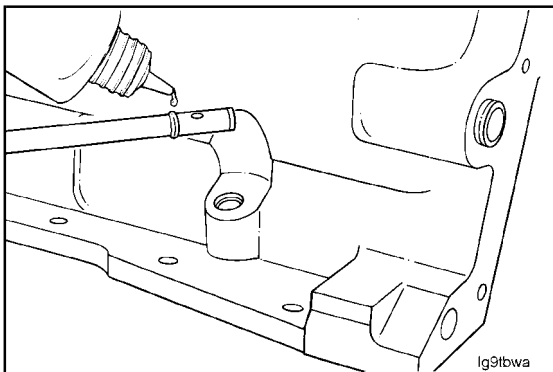

**Install (007-011-026)**

Apply a thin bead of Loctite™ 277 around the bottom of the knurled end of the tube.

**B3.9 and B5.9 Series Engines  
Section 7 - Lubricating Oil System - Group 07**

Place knurled end of tube into the dipstick tube bore in the cylinder block.

Use a flat washer and hex head capscrew to drive the tube into the cylinder block.

Lightly drive the dipstick tube until it seats against the block casting.

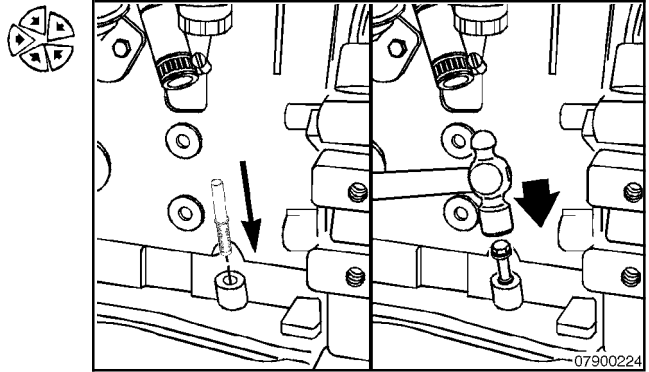

Install dipstick into the dipstick tube.

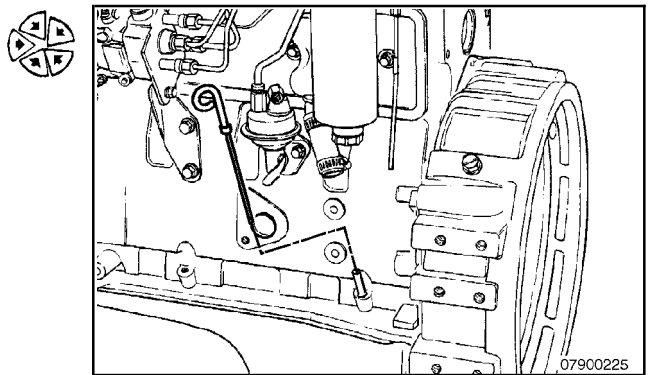

**Lubricating Oil Filter (Spin-On)  
(007-013)**

**Remove (007-013-002)**

**Oil Filter Wrench, Part No. 3375049**

Clean the area around the lubricating oil filter head.

Use the oil filter wrench, Part No. 3375049, to remove the filter.

Clean the gasket surface of the filter head.

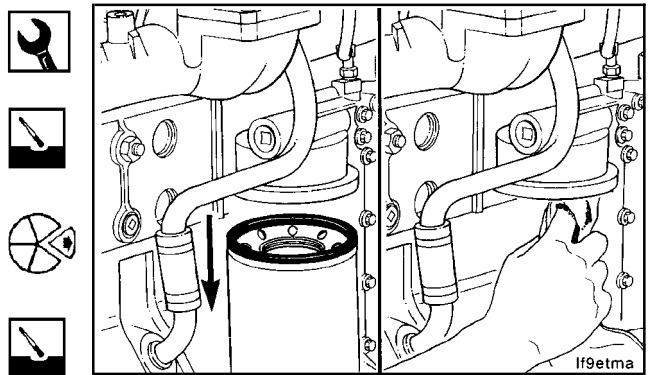

**Install (007-013-026)**

**⚠ CAUTION ⚠**

**The lack of lubrication during the delay until the filter is pumped full of oil at startup is harmful to the engine.**

Use clean lubricating engine oil to coat the gasket surface of the filter.

Fill the filter with clean lubricating engine oil.

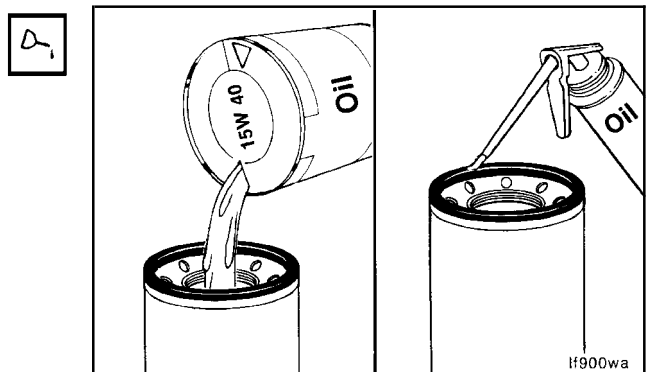

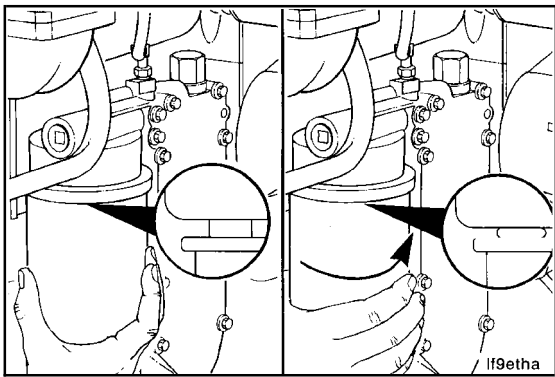

**CAUTION**

Mechanical overtightening of the filter can distort the threads or damage the filter element seal.



Oil Filter Wrench, Part No. 3375049

Install the filter on the oil filter head. Tighten the filter until the gasket contacts the filter head surface.



Use the oil filter wrench, Part No. 3375049, to tighten the filter. Refer to the instructions supplied with the filter.

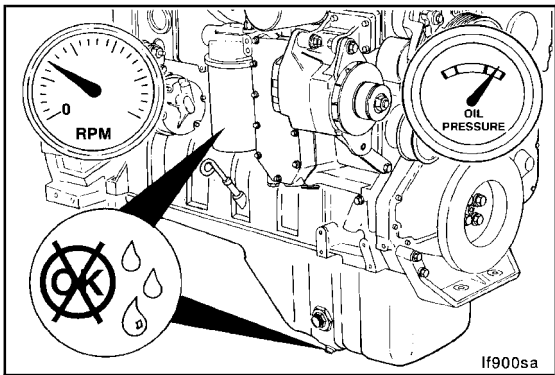

**CAUTION**

If oil pressure is not registered within 15 seconds, shut off the engine immediately to avoid engine damage.

Operate the engine, and check for leaks.

**NOTE:** Engine oil pressure **must** be indicated on the gauge within 15 seconds after starting. Confirm the correct oil level in the oil pan.

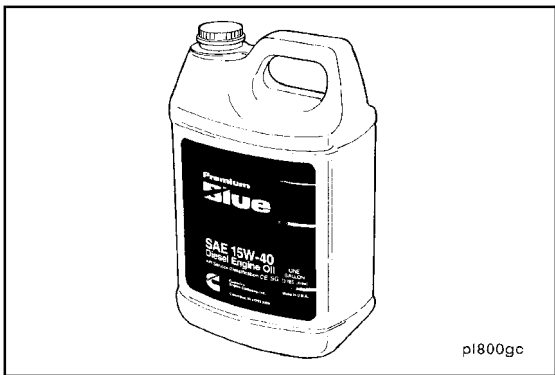

**Lubricating Oil Pan (007-025)**

**General Information**

Cummins Engine Company, Inc. recommends the use of a high-quality SAE 15W-40 heavy-duty engine oil (such as Cummins Premium Blue®) which meets the American Petroleum Institute (API) performance classification CE/SG.

**NOTE:** CC/CD or CD/SF engine oils can be used in areas where CE oil is **not** yet available, but the lubricating oil change interval **must** be reduced to one-half the interval given in the maintenance schedule.

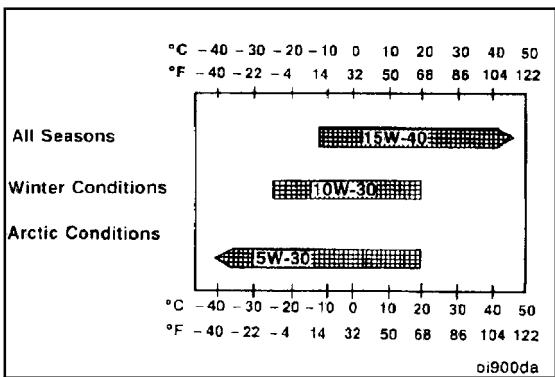

**CAUTION**

Limited use of lubricating oils, such as 10W-30, can aid in starting the engine and providing sufficient lubricating oil flow at ambient temperatures below -5°C [23°F]. However, the continuous use of low-viscosity lubricating oils can decrease engine life. Refer to the accompanying chart.

**Lubricating Oil Pan**

A front sump (1), rear sump (2), or center sump (3) lubricating oil pan option can be used depending on the application. The mounting of the lubricating oil pick up tube will vary with the lubricating oil pan used.

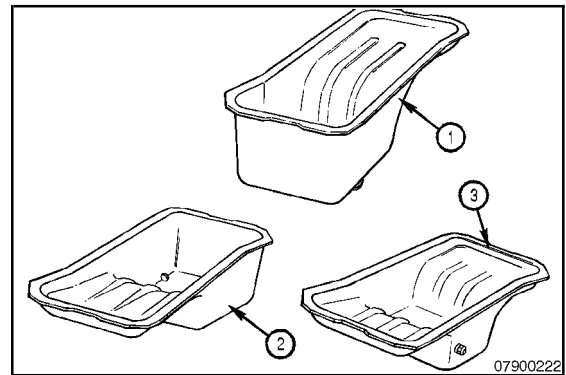

**High-Lubricating Oil Pressure**

High oil pressure usually occurs after the engine is first started in cold weather. Cold start oil pressure typically will be approximately 552 to 689 kPa [80 to 100 psi]. If the pressure regulator plunger is operating properly, the oil pressure should drop back to approximately of 449 kPa [65 psi] when normal operating temperature is reached.

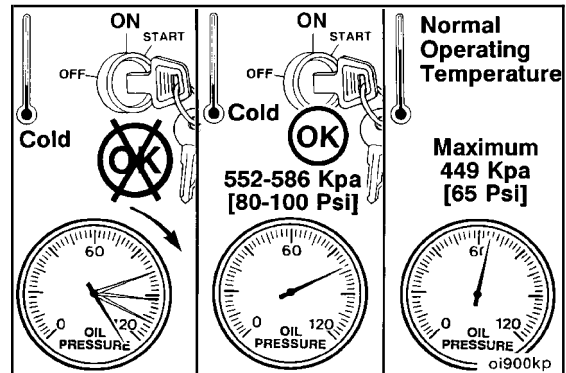

**Drain (007-025-005)**



Some state and federal agencies have determined that used engine oil can be carcinogenic and cause reproductive toxicity. Avoid inhalation of vapor, ingestion, and prolonged contact with used engine oil.



To avoid personal injury, avoid direct contact of hot oil with your skin.

**NOTE:** Use a container that can hold at least 20 liters [21 qt] of lubricating oil.

17 mm

Drain the lubricating oil.

Operate the engine until the coolant temperature reaches 60°C [140°F]. Shut off the engine. Remove the oil drain plug. Drain the oil immediately to make sure all the oil and suspended contaminants are removed from the engine.

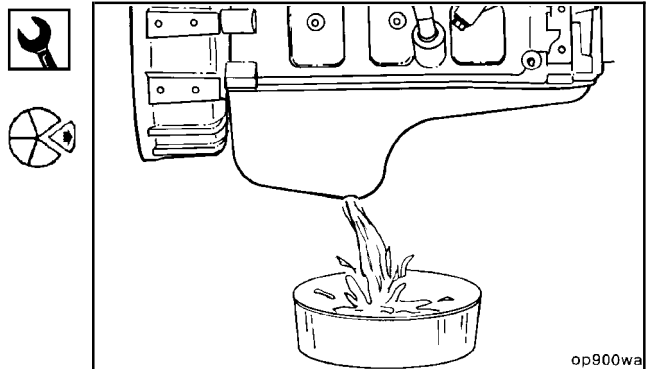

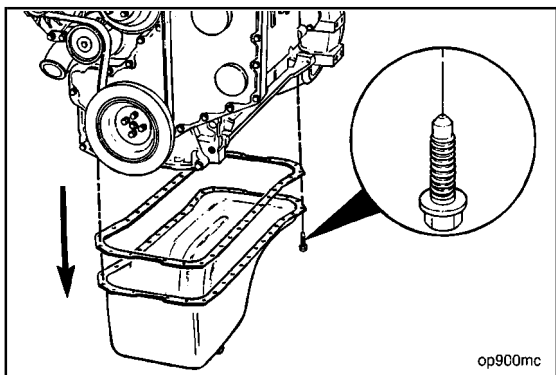

op900mc



**Remove (007-025-002)**

10 mm



Remove the lubricating oil pan and gasket.

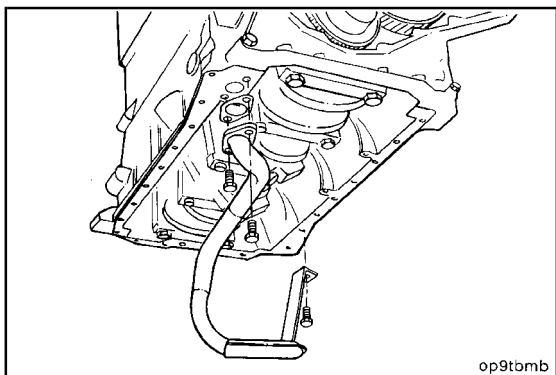

op9tbmb



Remove lubricating oil suction tube. Refer to Procedure 007-035.

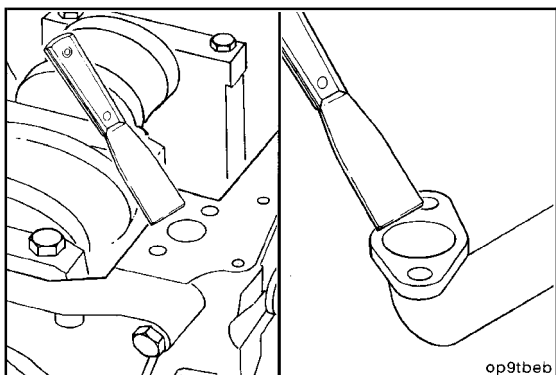

op9tbeb



**Clean (007-025-006)**

**▲ WARNING ▲**

When using solvents, acids, or alkaline materials for cleaning, follow the manufacturer's recommendations for use. Wear goggles and protective clothing to avoid personal injury.

**▲ WARNING ▲**

Wear appropriate eye and face protection when using compressed air. Flying debris and dirt can cause bodily injury.

Clean the gasket surfaces.

Remove all gasket material from the cylinder block and oil pan surface.

Steam-clean the oil pan, and dry with compressed air.

**Inspect for Reuse (007-025-007)**

Inspect the oil pan, suction tube, and tube braces for damage.

**NOTE:** If cracks are found, replace the damaged part. Do not attempt to repair the oil pan by welding.

If the suction tube **must** be replaced, refer to Procedure 007-035.

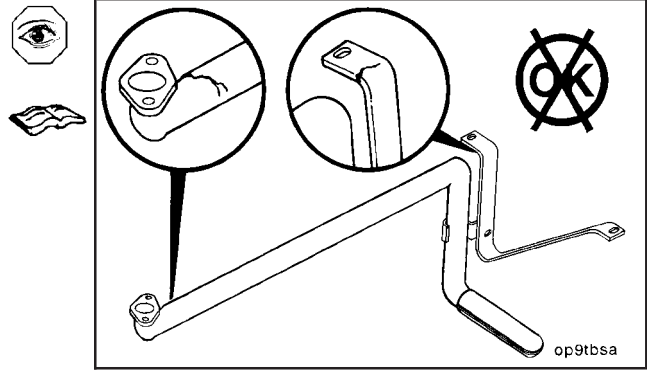

**Install (007-025-026)**

**Three-Bond™ Sealant, Part No. 3823494**

Use Three-Bond™ sealant to fill the joints between the lubricating oil pan rail, gear housing, and rear seal housing.

If the suction tube has been removed, refer to Procedure 007-035 for installation instructions.

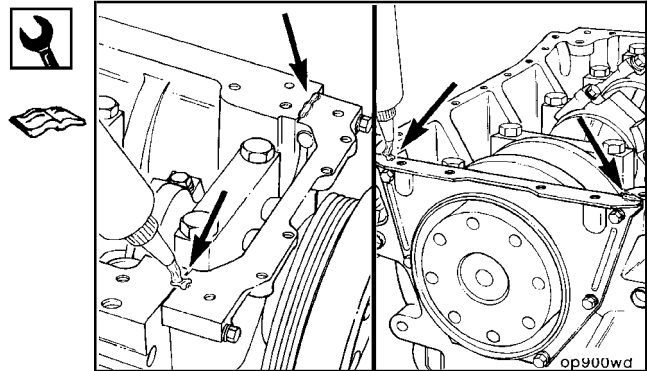

10 mm

**Three-Bond™ Sealant, Part No. 3823494**

Apply a 2-mm [1/16-in] bead of Three-Bond™ sealant, Part No. 3823494, to both sides of the new lubricating pan gasket.

Install the gasket and lubricating oil pan.

**Torque Value:** 24 N•m [18 ft-lb]

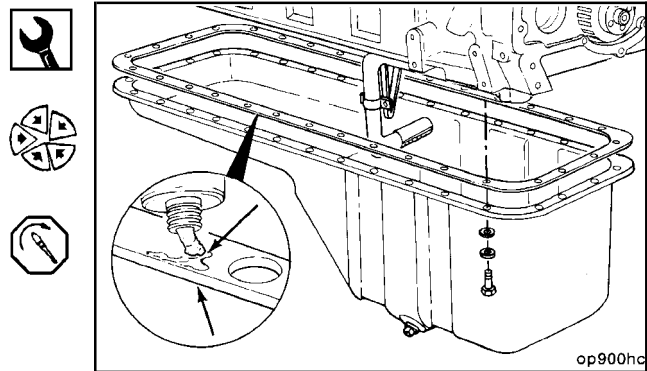

10 mm

Assemble the washers and capscrews to secure the lubricating oil pan as illustrated.

Tighten all capscrews in the sequence shown in the accompanying chart.

**Torque Value:** 24 N•m [18 ft-lb]

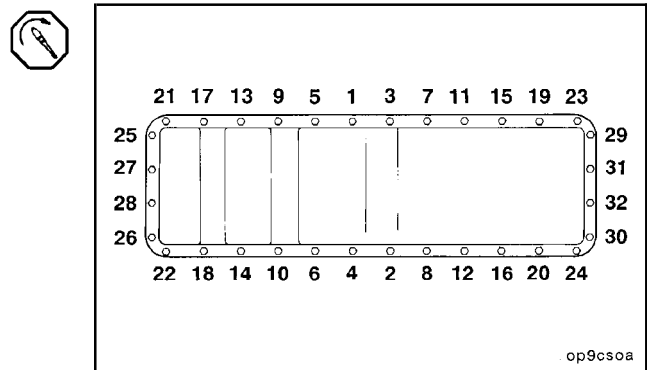

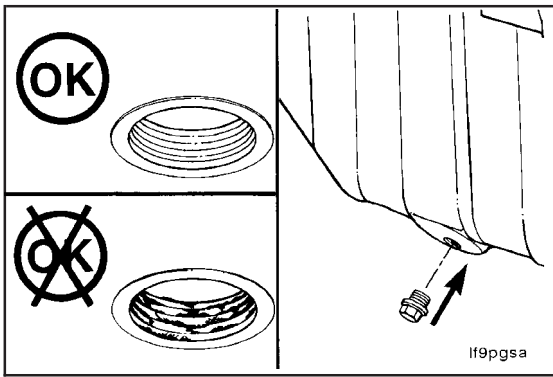

17 mm

Clean and check the lubricating oil drain plug threads and sealing surface.



Install the lubricating oil pan drain plug.

**Torque Value:** 60 N•m [44 ft-lb]

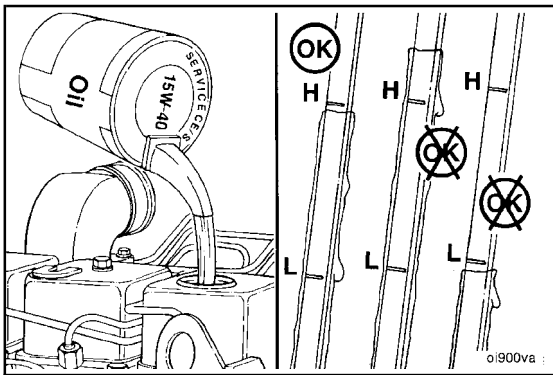

**Fill (007-025-028)**

Fill the engine with clean lubricating oil to the proper level.

Refer to Procedure 007-043 for proper oil level.



**NOTE:** Use a high-quality 15W-40 multiviscosity oil, such as Cummins Premium Blue®, or its equivalent in Cummins engines. Choose the correct oil for your operating climate as outlined in the Operation and Maintenance Manual, B Series Engine, Bulletin No. 3810205.

- Turbocharged engines: CF/SG
- Naturally aspirated engines: CD/CE/SG.

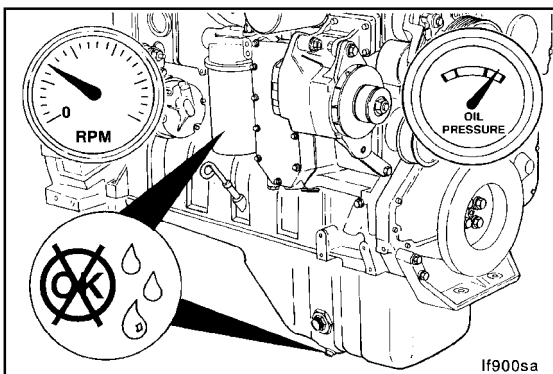

Idle the engine to inspect for leaks at the drain plug.

**NOTE:** Engine oil pressure **must** be indicated on the gauge within 15 seconds after starting. If oil pressure is **not** registered within 15 seconds, shut off the engine immediately to avoid engine damage. Confirm the correct oil level in the oil pan.



Shut off the engine. Wait approximately 5 minutes to let the oil drain from the upper parts of the engine. Check the level again.

Add oil as necessary to bring the oil level to the "H" (high) mark on the dipstick.

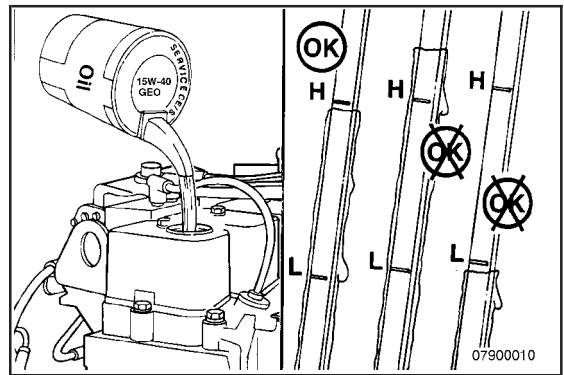

### Lubricating Oil Pressure Regulator (Main Rifle) (007-029)

#### Preparatory (007-029-000)

Thoroughly clean the area around the pressure regulator plug to prevent debris from falling into the plunger bore when the plug is removed.

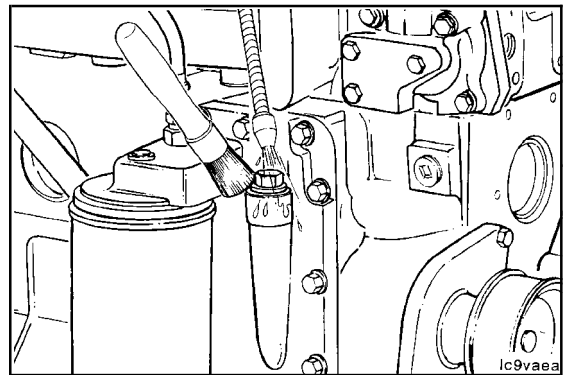

#### Remove (007-029-002)

19 mm

Remove the threaded plug, spring, and plunger.

**Service Tip:** The plunger normally can be removed by inserting one finger into the plunger bore until snug and pulling up. If the plunger can **not** be removed in this manner, the plunger is probably stuck and will require removal of the housing for plunger removal and cleaning.

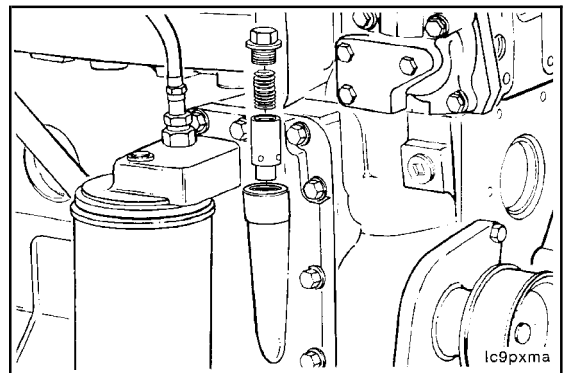

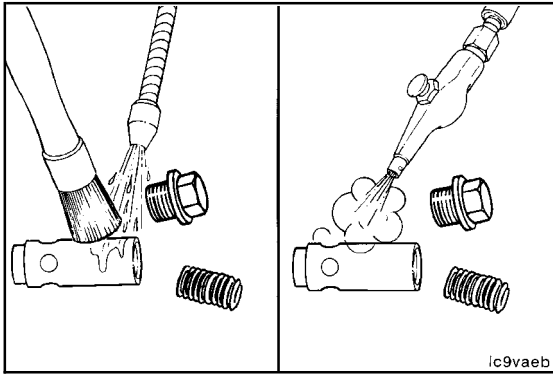

**Clean (007-029-006)**

**▲ WARNING ▲**

When using solvents, acids, or alkaline materials for cleaning, follow the manufacturer's recommendations for use. Wear goggles and protective clothing to avoid personal injury.

**▲ WARNING ▲**

Wear appropriate eye and face protection when using compressed air. Flying debris and dirt can cause bodily injury.

**▲ CAUTION ▲**

Compressed air used for cleaning should not exceed 207 kPa [30 psi]. Failure to do so can cause engine component damage.

Thoroughly clean all components with clean solvent.

Dry with compressed air.

**NOTE:** If the plunger bore requires cleaning, remove the housing so as **not** to flush debris into the engine.

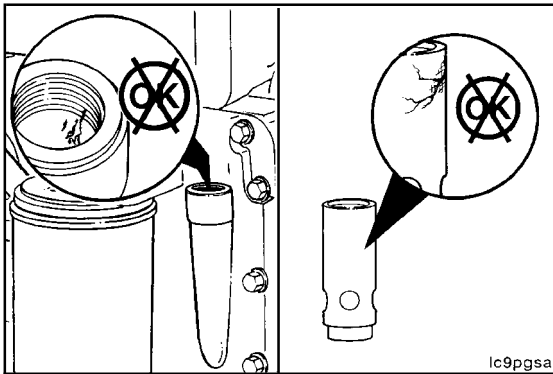

**Inspect for Reuse (007-029-007)**

Inspect the plunger and plunger bore. Polished areas on the plunger and bore are acceptable.

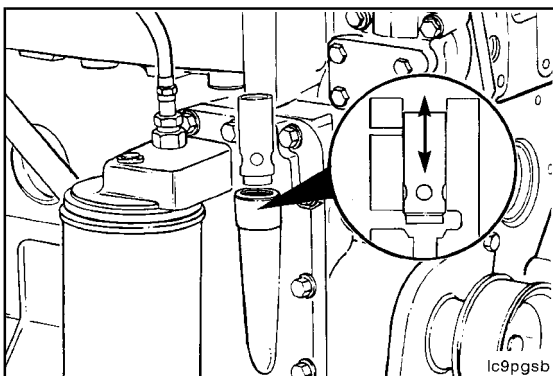

Verify the plunger moves freely in the bore.

**Install (007-029-026)**

19 mm

Install a new sealing o-ring on the threaded plug and lubricate with clean lubricating engine oil. Install the pressure regulator assembly.

**Torque Value:** 80 N•m [59 ft-lb]

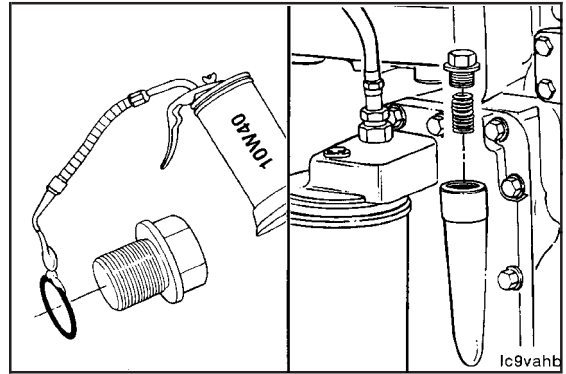

**Lubricating Oil Pump (007-031)**

**Preparatory (007-031-000)**

- Remove the drive belt. Refer to Procedure 008-002.

**NOTE:** Removal is easier if the vibration damper is loosened before removing the belt. Refer to Procedure 001-052.

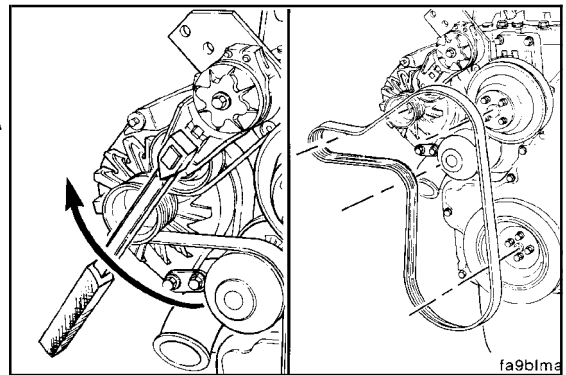

**Remove (007-031-002)**

15 mm

Remove the vibration damper. Refer to Procedure 001-052.

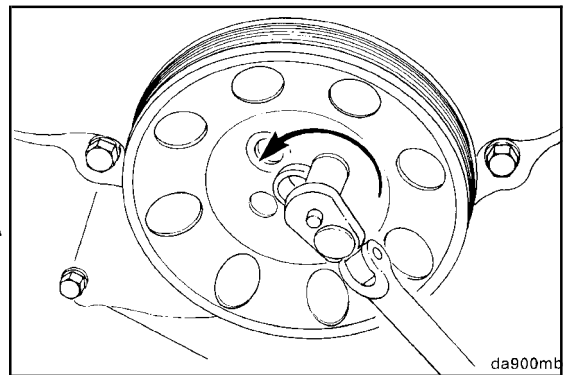

10 mm

Remove the front cover. Refer to Procedure 001-031.

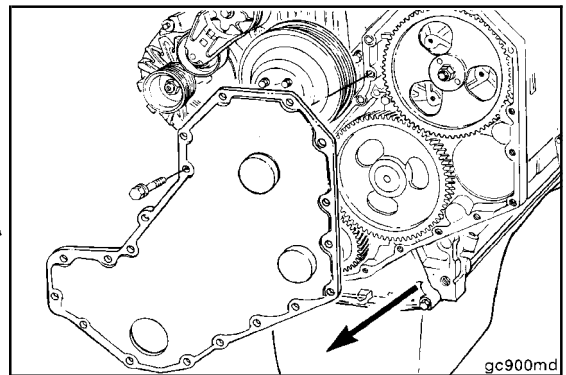

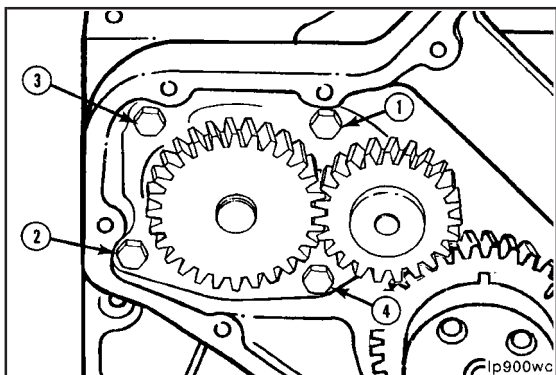

13 mm

Remove the four mounting capscrews.



Remove the pump from the bore in the cylinder block.

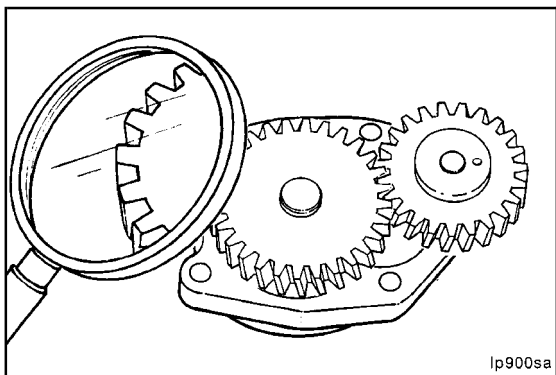

**Inspect for Reuse (007-031-007)**

If the lubricating oil pump is to be inspected for reuse, follow these steps.

Inspect the lubricating oil pump gears for chips, cracks, or excessive wear.

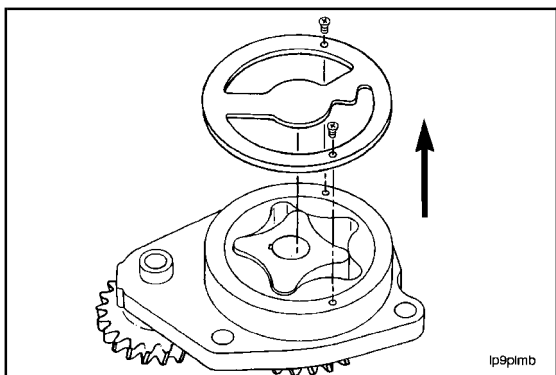

Remove the back plate.

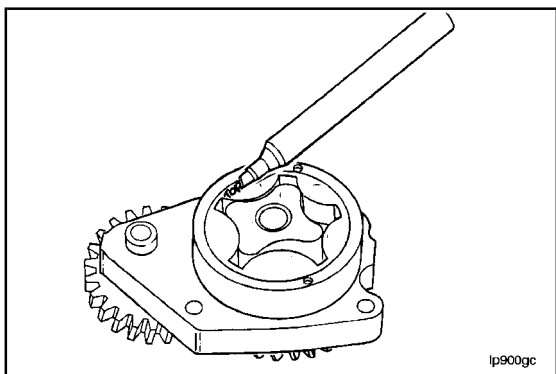

Mark "TOP" on the gerotor planetary.

**B3.9 and B5.9 Series Engines  
Section 7 - Lubricating Oil System - Group 07**

Remove the gerotor planetary.  
Inspect for excessive wear or damage.

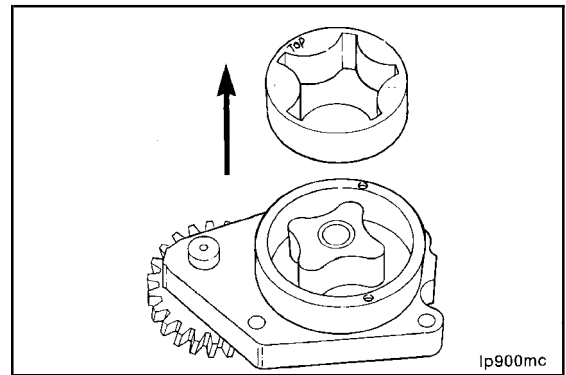
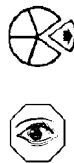

**⚠ WARNING ⚠**

When using solvents, acids, or alkaline materials for cleaning, follow the manufacturer's recommendation for use. Wear goggles and protective clothing to avoid personal injury.

**⚠ WARNING ⚠**

Wear appropriate eye and face protection when using compressed air. Flying debris and dirt can cause bodily injury.

Clean all parts in solvent, and dry with compressed air.

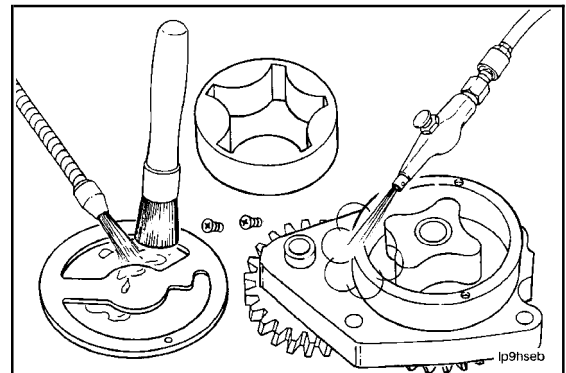

Inspect the lubricating oil pump housing and gerotor drive for damage and excessive wear.

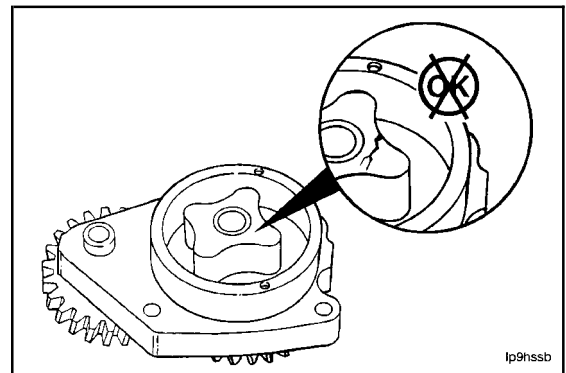

**⚠ CAUTION ⚠**

Be sure the gerotor planetary is installed in the original position. Failure to do so can cause engine damage.

Install the gerotor planetary.

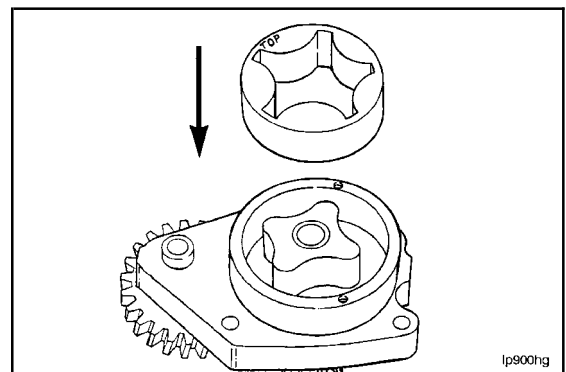

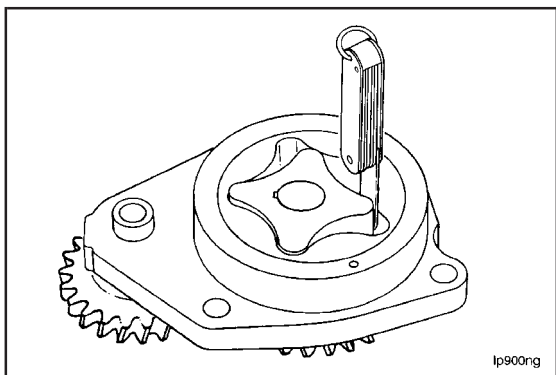

Measure the tip clearance.

Limit		
mm		in
0.1778	MAX	0.007

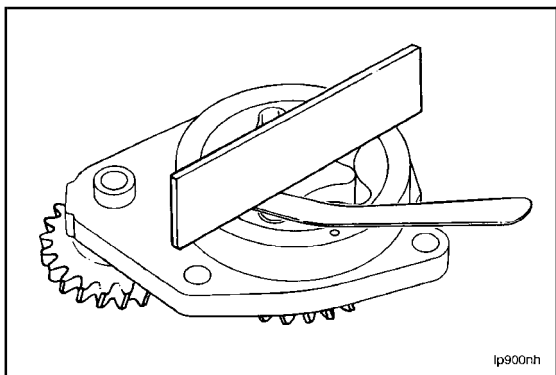

Measure the clearance of the gerotor drive/gerotor planetary to port plate.

Limit		
mm		in
0.127	MAX	0.005

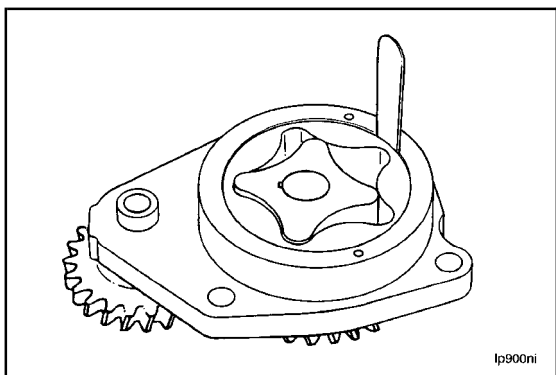

Measure the clearance of the gerotor planetary to the body bore.

Limit		
mm		in
0.381	MAX	0.015

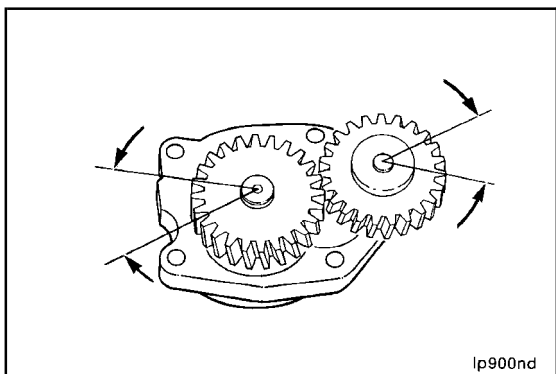

Measure the gears backlash.

Limits (Used Pump)		
mm		in
0.076	MIN	0.003
0.330	MAX	0.013

**Install (007-031-026)**

Install the back plate.

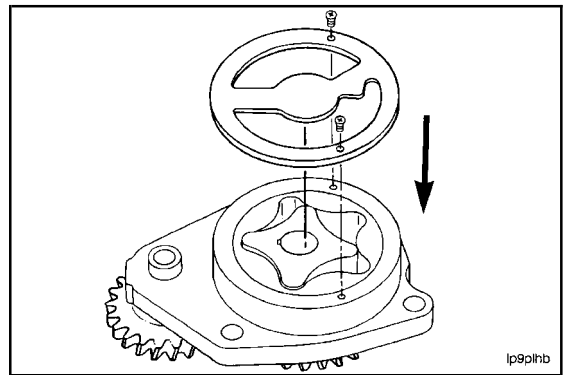

**⚠ CAUTION ⚠**

Failure to fill the pump with oil during installation can result in a slow prime at initial engine start-up, resulting in severe engine damage.

Lubricate the lubricating oil pump with clean lubricating engine oil.

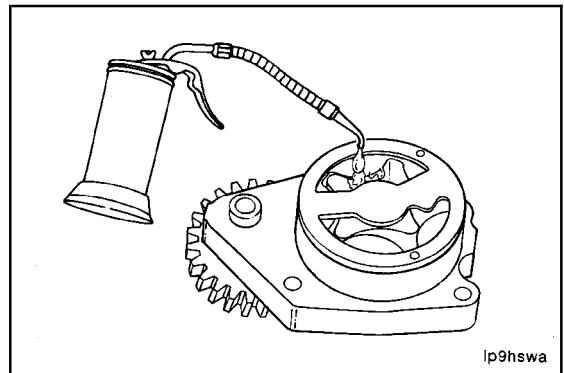

**⚠ CAUTION ⚠**

Make sure the idler gear pin is installed in the locating bore in the cylinder block. Failure to do so can cause engine damage.

Install the lubricating oil pump.

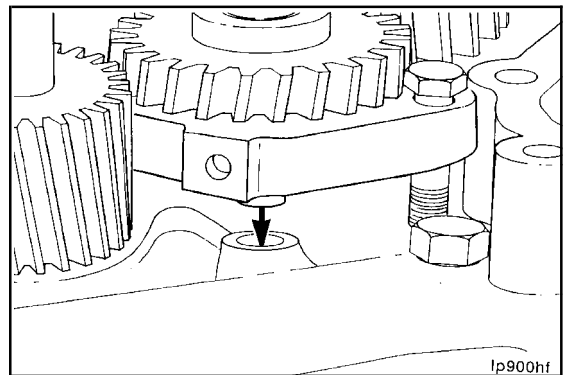

**13 mm**

Tighten in the sequence shown.

**Torque Value:** 24 N•m [18 ft-lb]

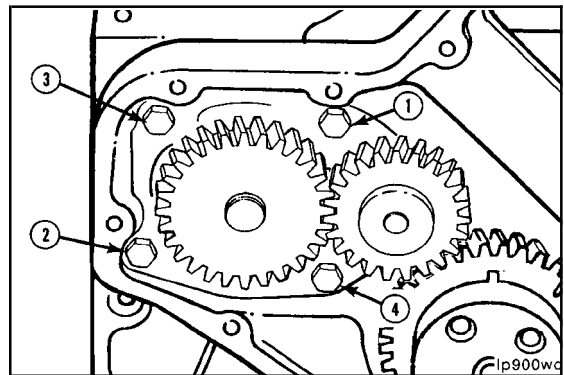

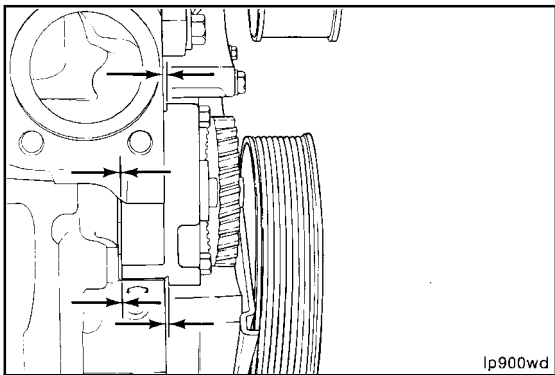

**NOTE:** The back plate on the pump seats against the bottom of the bore in the cylinder block. When the lubricating oil pump is correctly installed, the flange on the lubricating oil pump will **not** touch the cylinder block.

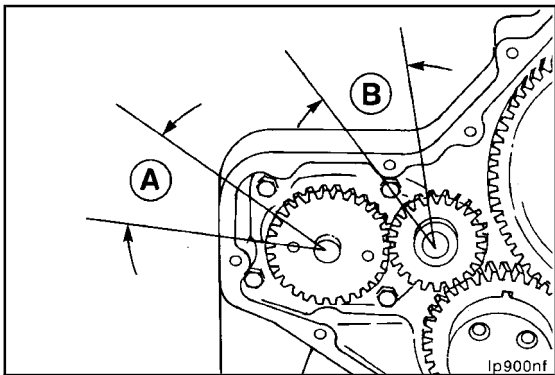

**NOTE:** Be sure the gear backlash is correct if installing a new lubricating oil pump.

Measure the gear backlash.

Backlash Limits			
	mm		in
A	0.076	MIN	0.003
	0.330	MAX	0.013
B	0.076	MIN	0.003
	0.330	MAX	0.013

**NOTE:** If the adjoining gear moves when you measure the backlash, the reading will be incorrect.

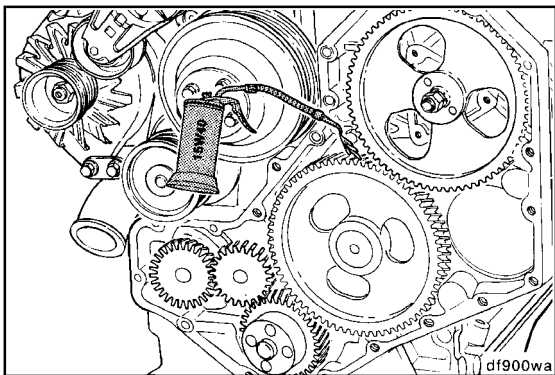

**Gear Cover - Installation**

Lubricate the front gear train with clean lubricating engine oil.

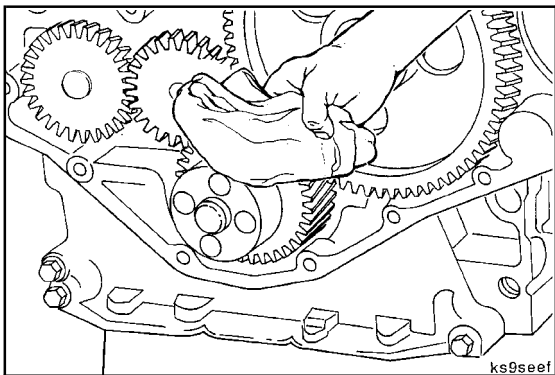

**CAUTION**

The seal lip and the sealing surface on the crankshaft must be free from all oil residue to prevent seal leaks.

Thoroughly clean the front seal area of the crankshaft.

**NOTE:** Always replace the front seal when removing and installing the gear cover.



**B3.9 and B5.9 Series Engines**  
**Section 7 - Lubricating Oil System - Group 07**

10 mm

**Three-Bond™ Sealant, Part No. 3823494**

Apply a thin bead of Three-Bond™ sealant, Part No. 3823494, or equivalent, to the front cover side of the gasket **only**.

**NOTE:** Do **not** remove the plastic seal pilot tool from the lubricating oil seal at this time. Use the plastic seal pilot tool to guide the seal on the crankshaft.

Install the gasket and front cover on the engine.

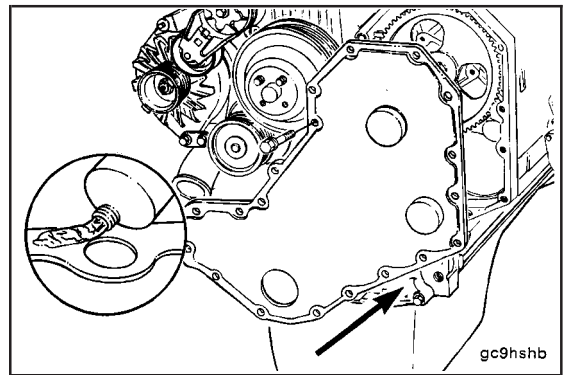

Tighten the front cover mounting capscrews.

Remove the plastic pilot tool from the crankshaft.

**Torque Value:** 24 N•m [18 ft-lb]

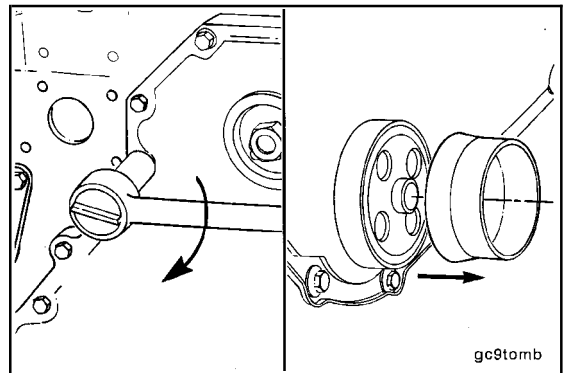

Install the front cover access cap and seal.

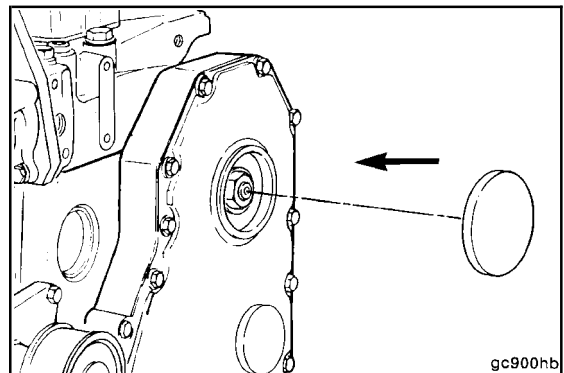

15 mm

Install the crankshaft pulley or vibration damper. Do **not** tighten the capscrews to the correct torque value at this time.

Refer to Procedure 001-052.

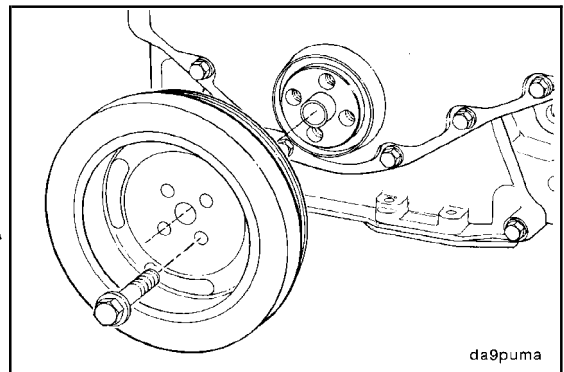



**1/2-Inch Square Drive**

Raise the belt tensioner to install the belt.

Refer to Procedure 008-087.

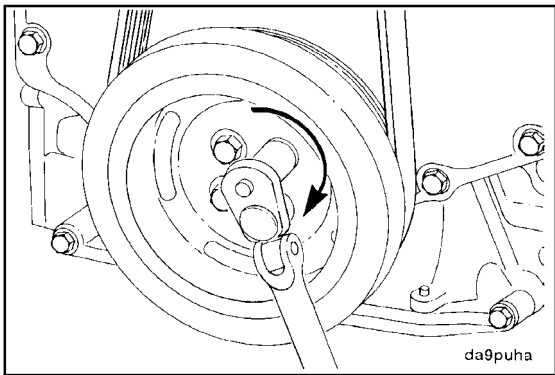

**15 mm**

Tighten the vibration damper.

Refer to Procedure 001-052.

**Torque Value:** 125 N•m [92 ft-lb]

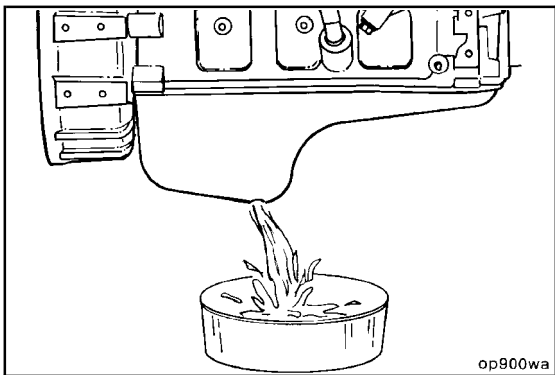

**Lubricating Oil Suction Tube (Block-Mounted) (007-035)**

**Preparatory (007-035-000)**

**NOTE:** Use a container that can hold at least 20 liters [15 qts] of lubricating oil.

- Drain the lubricating oil. Refer to Procedure 007-025.
- Remove the lubricating oil pan and gasket. Refer to Procedure 007-025.

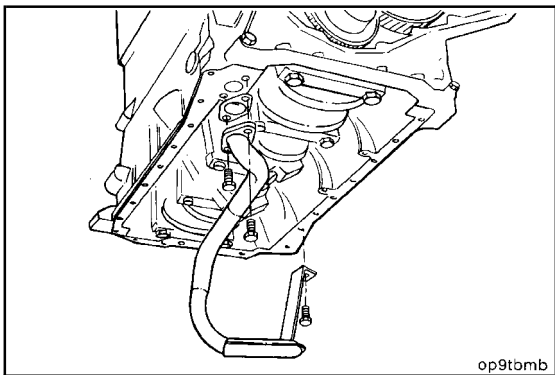

**Remove (007-035-002)**

**10 mm**

Remove the lubricating oil suction tube.



**Clean (007-035-006)**

Clean the gasket surfaces.

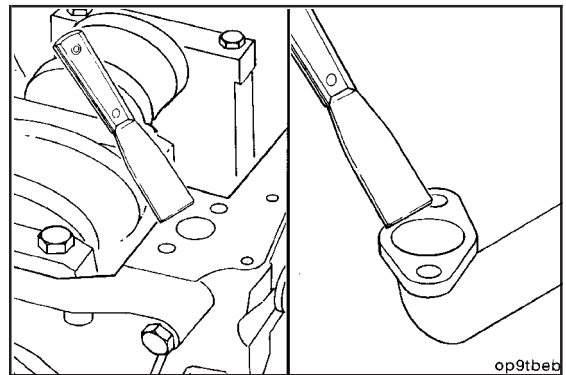

op9tbeb

**Inspect for Reuse (007-035-007)**

Inspect the suction tube for cracks.

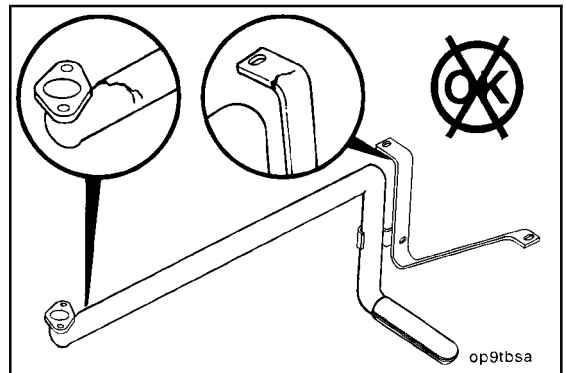

op9tbsa

**Install (007-035-026)**

10 mm

Install the lubricating oil suction tube and new gasket.

**Torque Value:** 24 N•m [18 ft-lb]

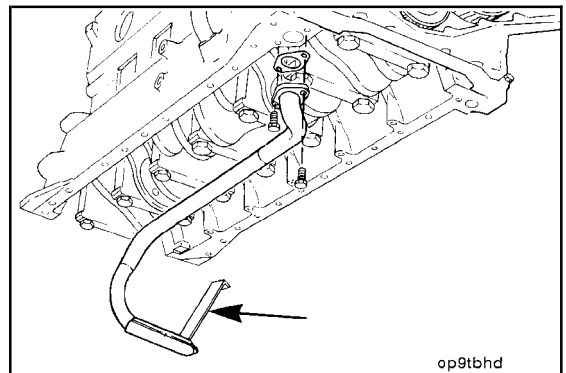

op9tbhd

**Three-Bond™ Sealant, Part No. 3823494**

Use Three-Bond™ 1207-C sealant, Part No. 3823494, or equivalent, to fill the joints between the lubricating oil pan rail, gear housing, and rear seal housing.

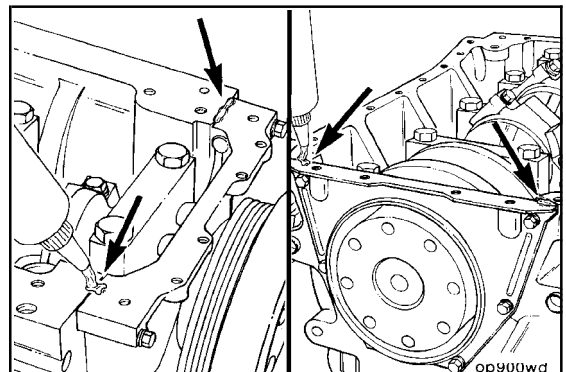

op900wd

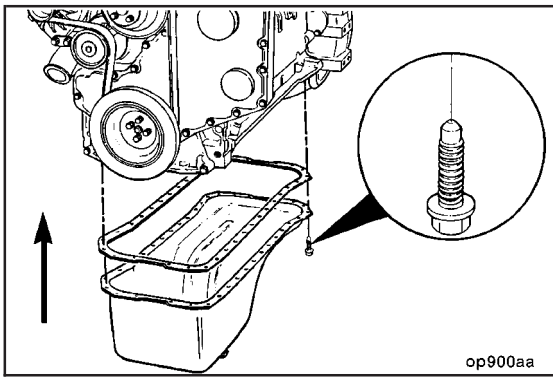

10 mm

Install the lubricating oil pan and gasket. Refer to Procedure 007-025.



**Torque Value:** 24 N•m [18 ft-lb]

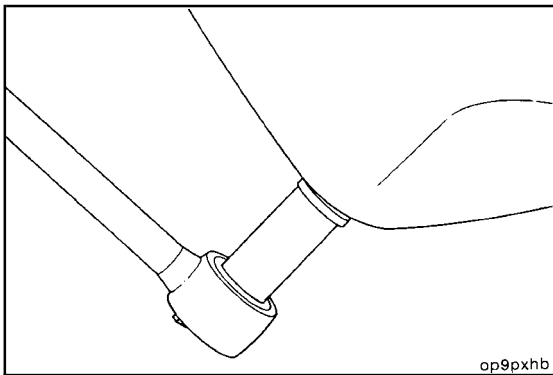

17 mm

Install the lubricating oil pan drain plug.



**Torque Value:** 80 N•m [59 ft-lb]

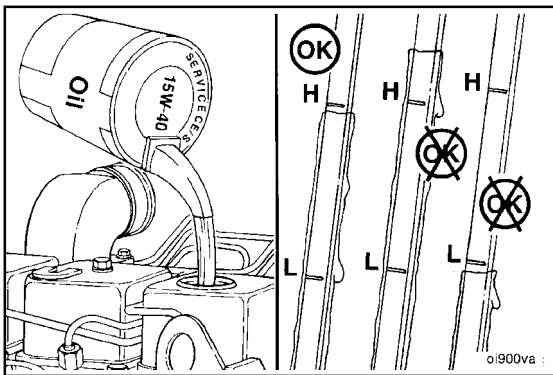

**Fill (007-035-028)**

Fill the engine with lubricating oil. Refer to the Operation and Maintenance Manual, B Series Engines, Bulletin No. 3810205, for lubricating oil specification.



Operate the engine and check for leaks.

Stop the engine and check the lubricating oil level with the dipstick. Refer to Procedure 007-043.

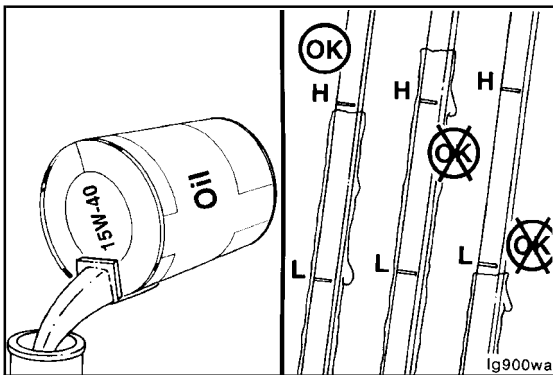

**Lubricating Oil Level (007-043)**

**Initial Check (007-043-001)**

**NOTE:** When filling the oil pan, use the fill tube on the side of the engine rather than on top of the rocker lever cover.

Fill the engine with clean lubricating oil to the proper level.

Idle the engine to inspect for leaks at the drain plug.

**B3.9 and B5.9 Series Engines  
Section 7 - Lubricating Oil System - Group 07**

Shut off the engine. Wait approximately 5 minutes to let the oil drain from the upper parts of the engine.

Check the oil level again.

Add oil as necessary to bring the oil level to the "H" (high) mark on the dipstick.

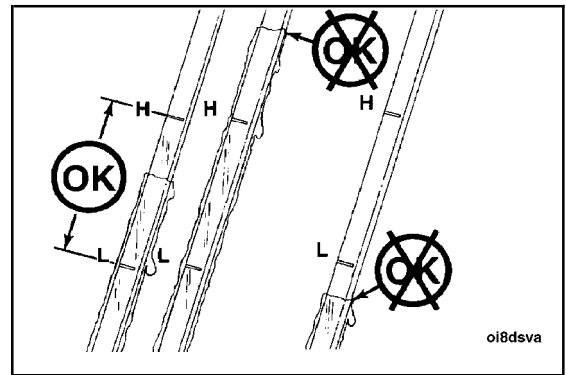

**Lubricating Oil Contamination (007-044)**

**General Information**

**Lubricating Oil Dilution**



**Diluted oil can cause severe engine damage.**

Check the condition of the lubricating oil.

- Thin, black lubricating oil is an indication of fuel in the oil.
- Milky discoloration is an indication of coolant in the lubricating oil.

Coolant in the oil can be caused by:

- Expansion plugs leaking
- Lubricating oil cooler element leaking
- Damaged cylinder head or gasket
- Cracked engine block
- Casting porosity.

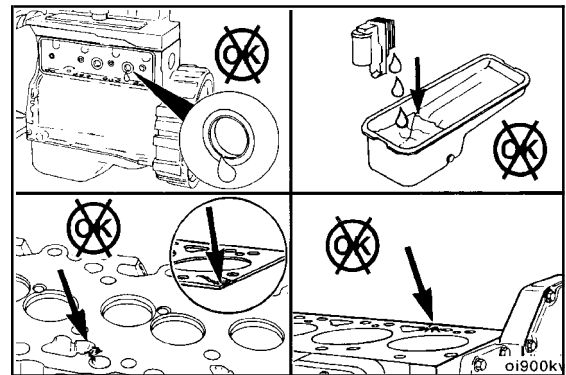
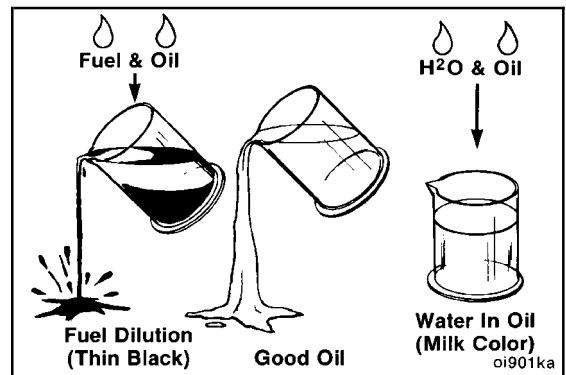

**Coolant-Diluted Lubricating Oil**

Since the lubricating oil cooler design does **not** require gaskets or seals to maintain the separation of oil and coolant, the element itself **must** leak to allow mixing of the fluids. Refer to Procedure 007-003.

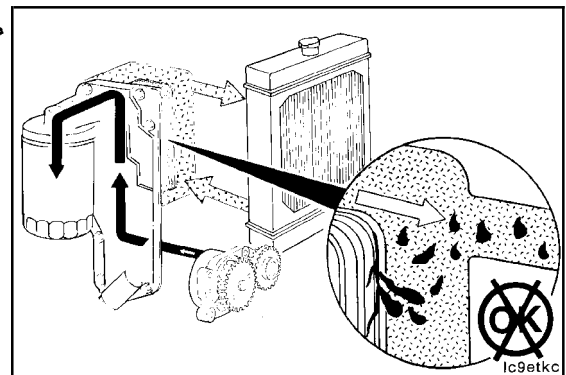

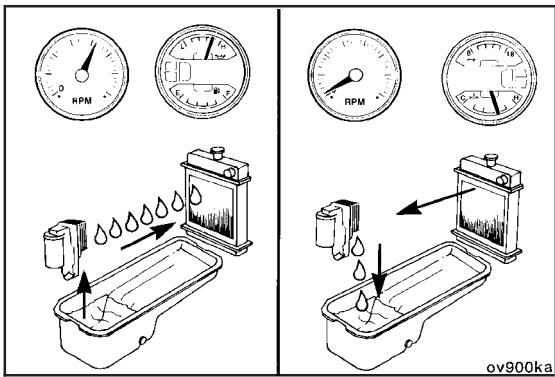

During operation, the lubricating oil pressure will be higher than coolant pressure. A leak in the lubricating oil cooler will show as lubricating oil in the coolant.

However, following an engine shutdown, the residual pressure in the coolant system can cause coolant to seep through the leak path into the lubricating oil.

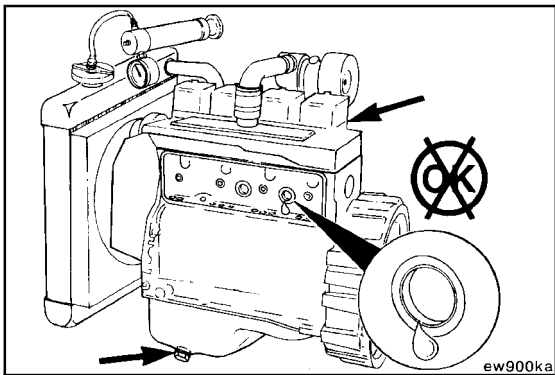

To check for leaks, pressurize the cooling system to 140 kPa [20 psi]. With the system pressurized, remove the following components, and inspect for leaks.

- Valve covers (leaks indicate cracked head)
- Lubricating oil drain plug (leaks indicate defective lubricating oil cooler, head gasket, cracked head or block)
- Tappet cover (expansion plug leak).

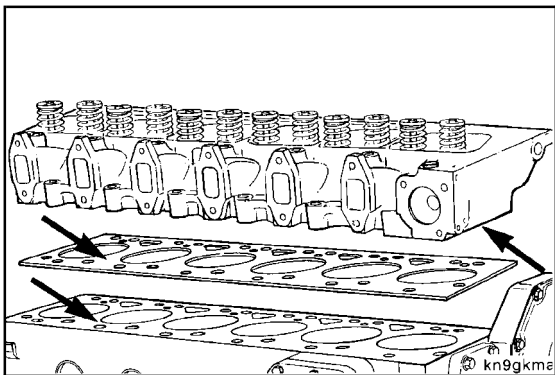

Coolant in the lubricating oil can be caused by a damaged cylinder head gasket or cracked cylinder head or block.

Remove the cylinder head and gasket, and inspect for cracks or damage.

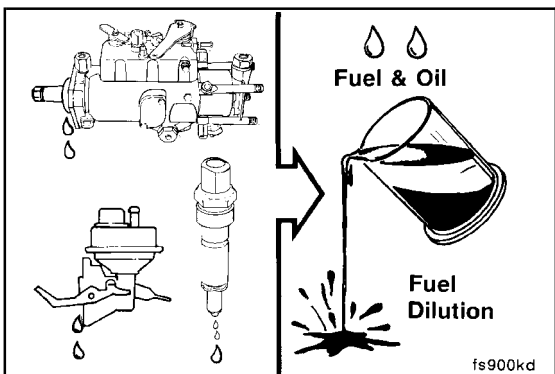

**Fuel-Diluted Lubricating Oil**

Fuel dilution is limited to five sources:

1. Injection pump shaft seal
2. Fuel leaking by the rings
3. Fuel transfer pump
4. A crack in the cylinder head from the fuel filter location to the air intake
5. Injector leakage.

Use the following logic to determine the source of the oil dilution with fuel:

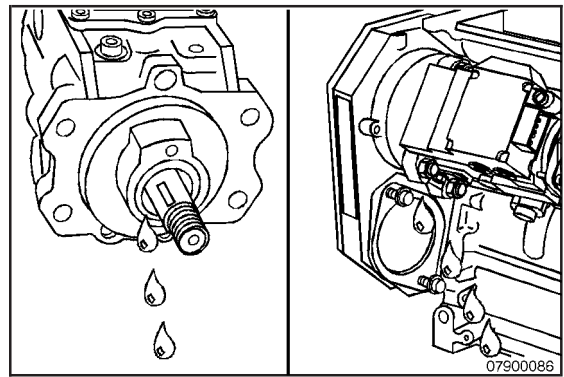

A worn or damaged fuel injection pump shaft seal will allow fuel to leak into the gear housing and then into the lubricating oil pan.

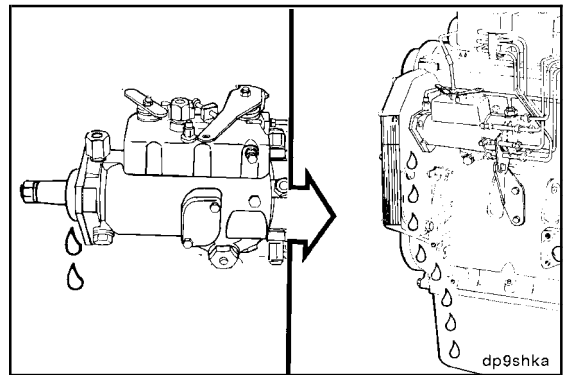

The seal is designed to provide increased sealing as the pump case pressure increases. Pressure forces the lip (1) tighter around the shaft.

A worn seal could leak during start-up and shutdown when case pressure is low. A worn seal can **not** easily be detected by pressurizing the pump.

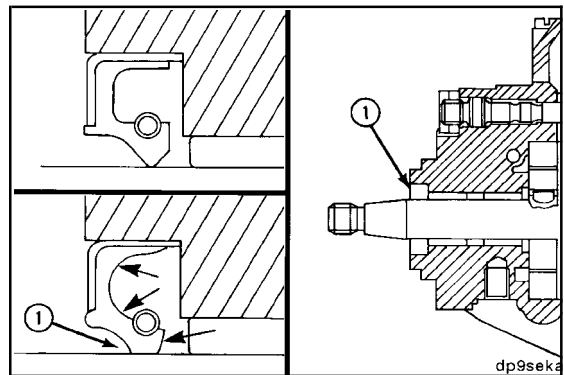

The bushing (2) in the **Bosch® VE** fuel injection pump can cause a seal leak. If the bushing is loose in the housing, it will move toward the seal raising the lip (1) and providing a leak path for fuel.

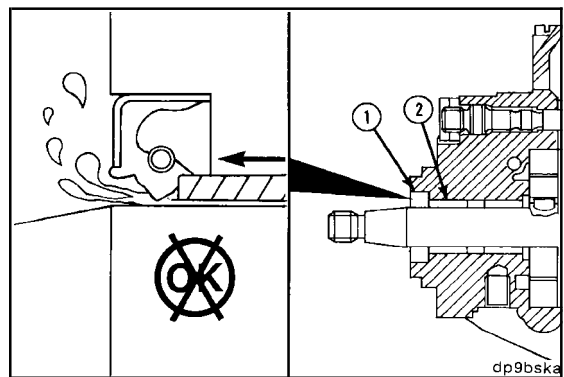

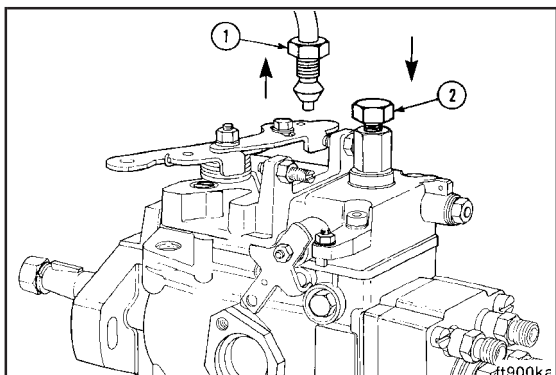

To check for such a leak, or a damaged seal (**Bosch® VE only**), remove the fuel drain manifold connection (1) at the pump, and install a plug (2).

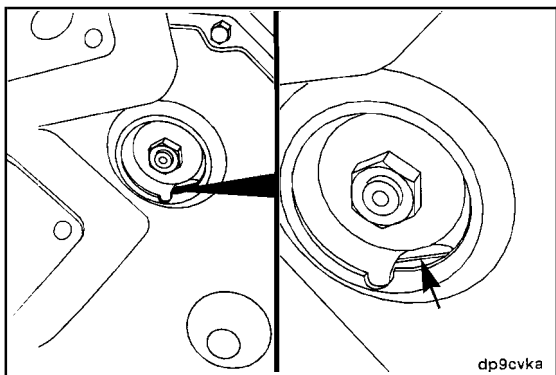

Remove the access cover, and rotate the engine so one of the holes in the fuel injection pump gear exposes the back gear housing.

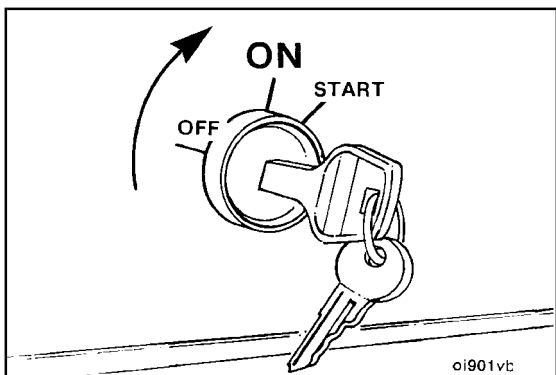

Activate the fuel shutdown valve by turning the switch to the ON position.

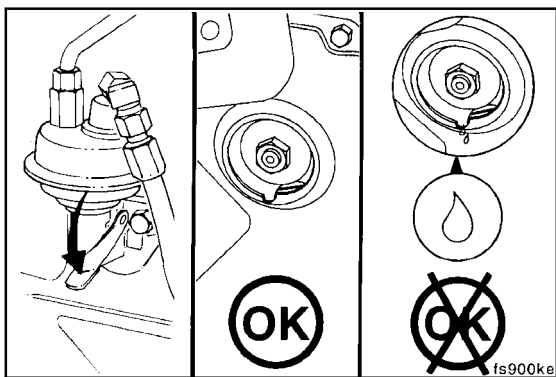

Use a small mirror to check for leaks while pumping the priming lever on the lift pump. If a leak is found, replace the injection pump. The seal can be replaced by a Cummins Authorized Service Center.



**B3.9 and B5.9 Series Engines**  
**Section 7 - Lubricating Oil System - Group 07**

Incomplete combustion in the cylinders can result in unburned fuel draining into the oil pan.

This condition can be caused by a leaking injector or reduced compression caused by inadequate piston ring sealing.

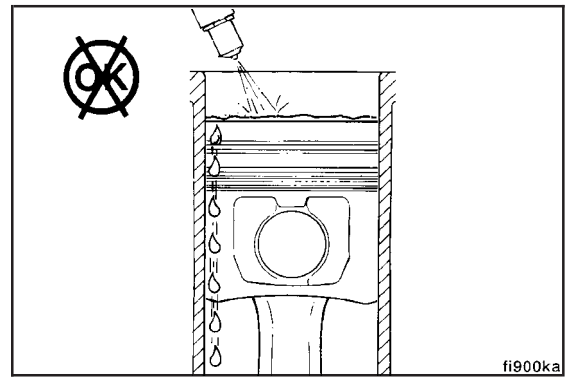

An **increase** in white exhaust smoke during the first start of the day is a symptom that an injector is leaking.

An injector leak will also cause the engine to run rough and have low power.

Remove and repair or replace leaking injectors. Refer to Procedure 006-026.

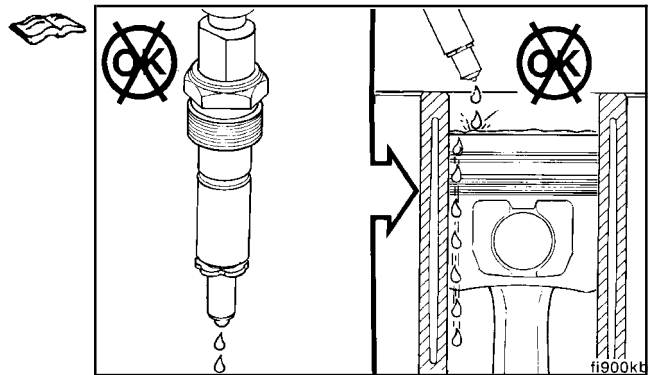

Perform a compression check to verify piston ring sealing. Refer to Procedure 014-008.

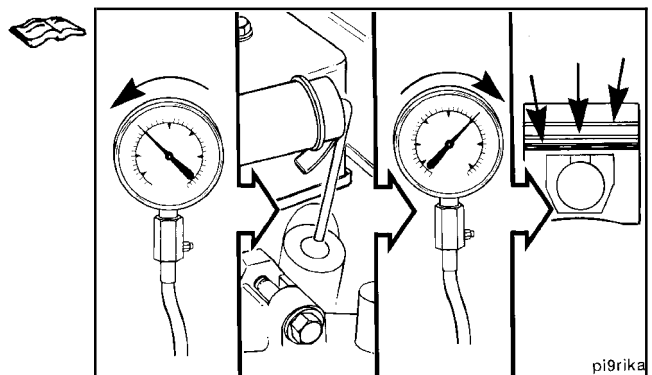

There is a remote possibility for fuel to drain into the oil from the diaphragm-type fuel transfer pump.

For this to happen, the diaphragm in the pump would have to break and the drain hole would have to be plugged.

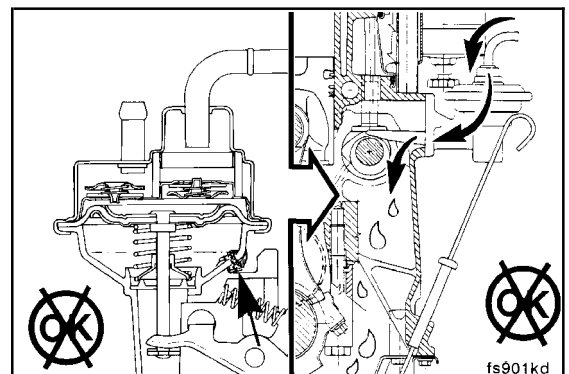

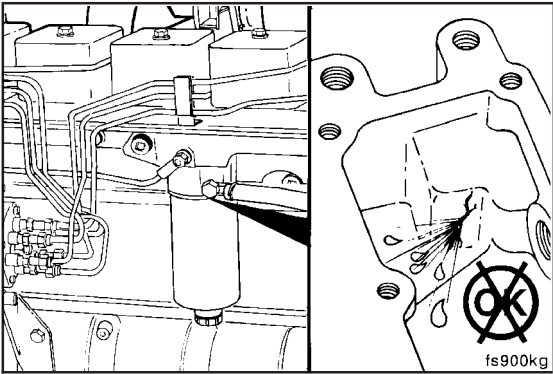

Another remote possibility, is that a crack or porosity in the head casting could allow fuel to leak to the air intake and onto the cylinders.

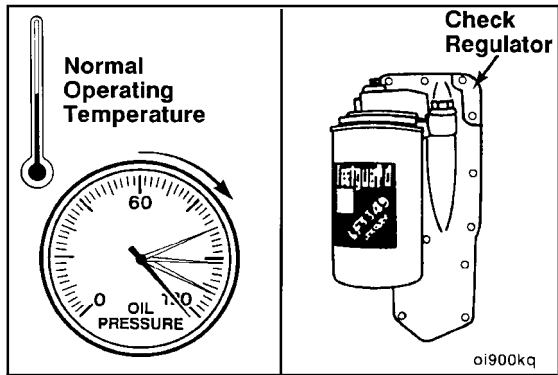

## Lubricating Oil System Diagnostics (007-048)



### General Information

#### Lubricating Oil Pressure Regulating Valve

The engine will have high oil pressure at normal operating temperature if the regulator sticks in the closed position. Check the regulator for freedom of movement.

Refer to Procedure 007-029.

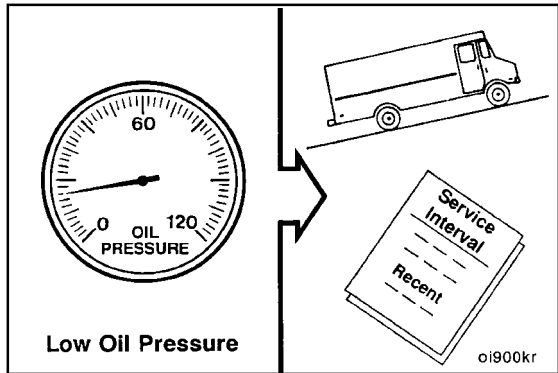

#### Low-Lubricating Oil Pressure

Low-lubricating oil pressure (or no oil pressure) can be caused by several lubrication system related malfunctions. To begin the investigation, determine the engine operating conditions when the low-pressure was first observed; i.e., following a service interval, at idle **only**, and while operating on a steep grade.

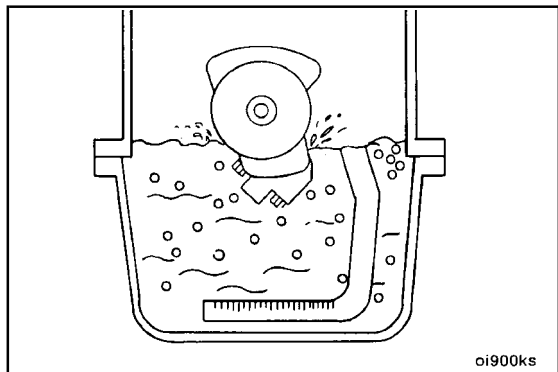

#### Lubricating Oil Level

High oil level can cause low oil pressure. If the oil level is high enough for the connecting rods to dip into during operation, the oil can become aerated, resulting in low oil pressure.

Low-lubricating oil level will **not** normally appear as low oil pressure. Typically, it will appear as an intermittent loss of oil pressure when rounding a corner or operating on a steep grade. This condition exists when the oil level is extremely low and the suction tube can **not** pick up oil during all modes of operation.

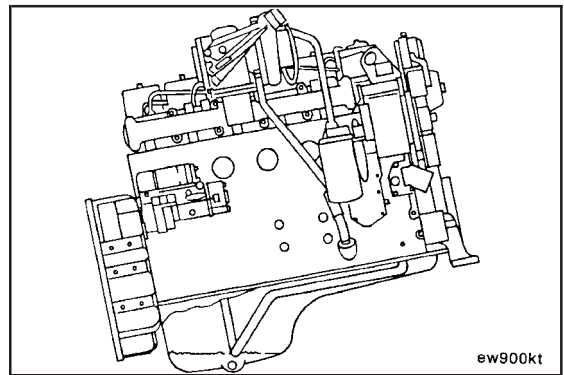

**Lubricating Oil Coolers**

The engines use full-flow, plate-type oil coolers. The oil flows through a cast passage in the cooler cover and through the element where it is cooled by engine coolant flowing past the plates of the element. The four-cylinder engine uses an element with five plates (A); the six cylinder uses an element with seven plates (B). Because of the differences in plate restriction and oil pump capacities, the oil cooler components are **not** interchangeable between the four-cylinder and six-cylinder engines. The use of incorrect components can cause high or low oil temperature, varnish, and sludge buildup.

**NOTE:** Prior to October 10, 1986, six-cylinder engines were assembled with nine-plate oil cooler elements.

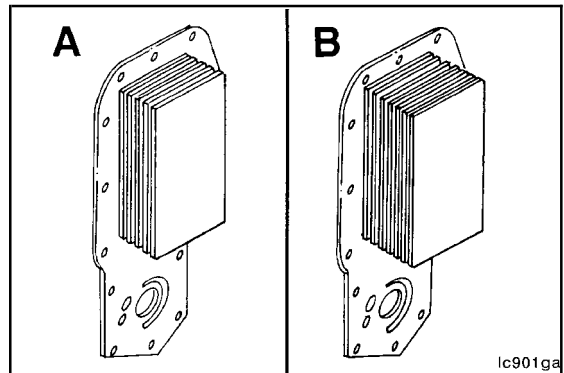

**Lubricating Oil Filter Bypass Valve**



The lubricating oil cooler cover contains a bypass valve that will let the lubricating oil flow bypass a plugged filter. The valve is designed to open when the pressure drop across the filter is more than 138 kPa [20 psi], as with a plugged filter, and lets the lubricating oil continue on through the engine. When a filter becomes plugged, an oil pressure decrease of 60 kPa [9 psi] or less from the normal operating pressure can be observed on the vehicle lubricating oil pressure gauge. This allows unfiltered oil into the engine. This condition should be avoided by changing the filter at each oil drain interval as described in the Operation and Maintenance Manual, B Series Engines, Bulletin No. 3810205.

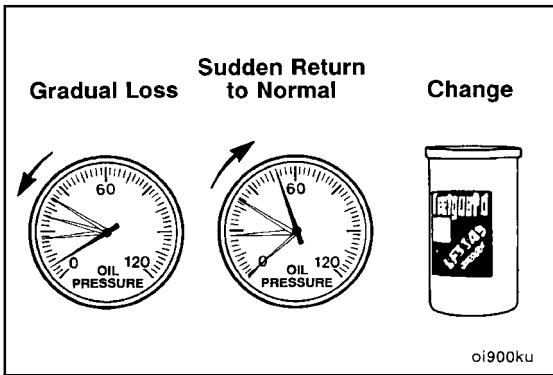

**CAUTION**

Using a filter for a six-cylinder engine on a four-cylinder engine does not allow extended change interval. Never use a filter for a four-cylinder engine on a six-cylinder engine because of the reduced material holding capability and increased chance of plugging. Failure to do so can cause engine damage.

**Lubricating Oil Filter**

After the oil is cooled, it flows through the full-flow oil filter. The filter for the six-cylinder engine is longer than the filter for the four-cylinder engine.

A plugged filter will cause a gradual loss of oil pressure by approximately 69 kPa [10 psi]. The pressure will return to normal when the filter bypass valve opens. If **not** corrected, this will result in severe engine wear, as the engine is running on unfiltered oil when the bypass valve is open.

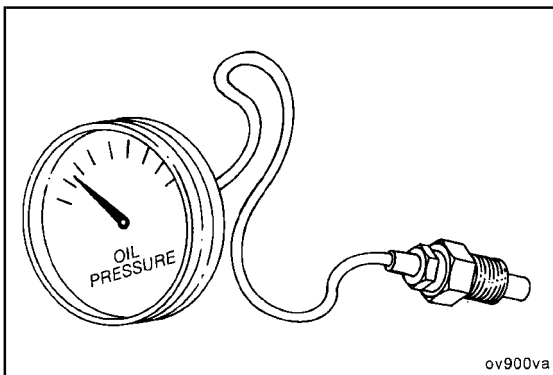

**Lubricating Oil Gauge**

Check the lubricating oil gauge and sending unit to make sure they are operating correctly by verifying the pressure with a manual gauge connected to the main oil rifle.

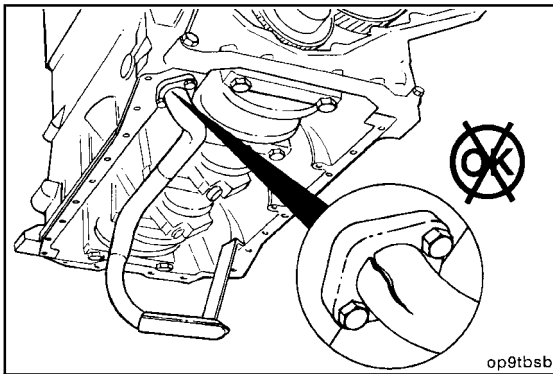

**Lubricating Oil Suction Tube**

A loose suction tube, damaged gasket, or crack in the suction tube can cause a temporary loss of prime for the oil pump. The engine will have low pressure or no oil pressure at starting, followed by normal oil pressure.

**Bearings and Lubricating Oil Pump**

A steady decrease in oil pressure over a long period can be an indication of worn bearings or excessive oil pump wear.

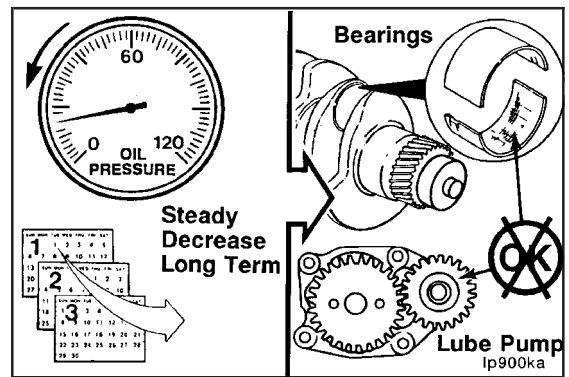

**Incorrect Lubricating Oil Pump**

The capacity of the six-cylinder oil pump is greater than the four-cylinder. If low or high pressure occurs after changing the pump, verify that the correct pump was used. Refer to Procedure 007-031.

**A - Four Cylinder**

- 12.947 mm [0.510 in]

**B - Six Cylinder**

- 17.947 mm [0.707 in]

**NOTE:** Earlier model B Series engines used lower capacity pumps. Check to be sure the correct model pump is used.

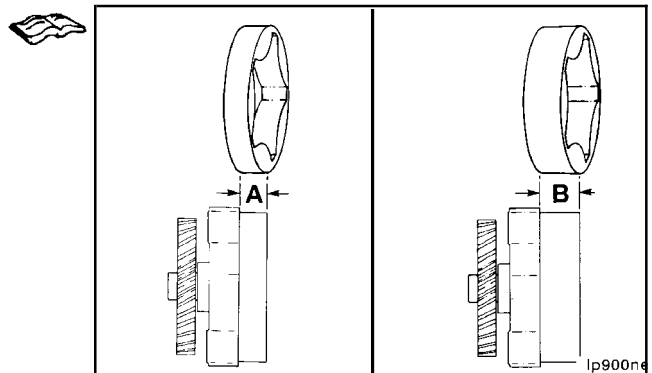

**Lubricating Oil Leaks**

Various gaskets, seals, and plugs are used to contain the lubricating oil. Most leaks can be identified during routine inspection of the engine and vehicle.

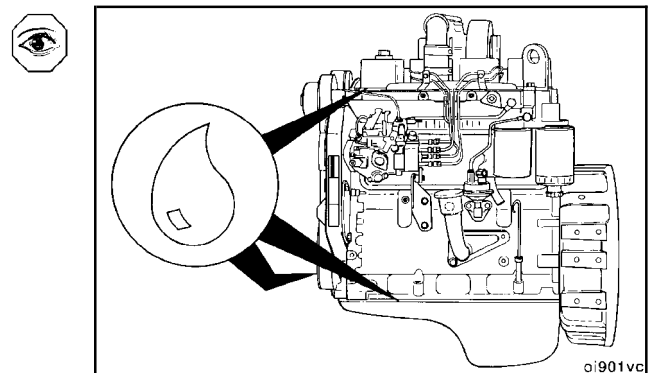

A blown expansion plug can allow a relatively large quantity of lubricating oil to escape, resulting in a sudden drop in the lubricating oil pressure.

When checking for such a leak, be sure to check the expansion plug behind the tappet cover as well as those that can be obscured by chassis parts.

Lubricating oil blowing out the breather is a good sign of a blown expansion plug. This is usually more obvious on a four-cylinder engine.

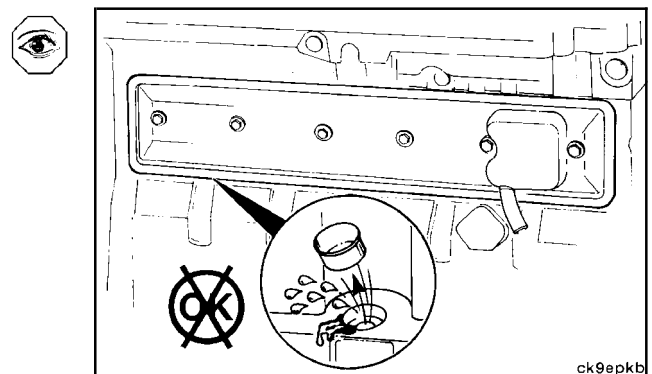

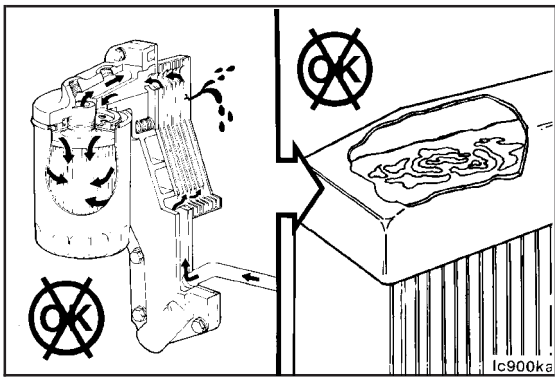

If the lubricating oil cooler element ruptures, the lubricating oil pressure will force lubricating oil into the coolant system. Lubricating oil in the coolant should be visible when the radiator cap is removed.



Refer to Procedure 007-003.

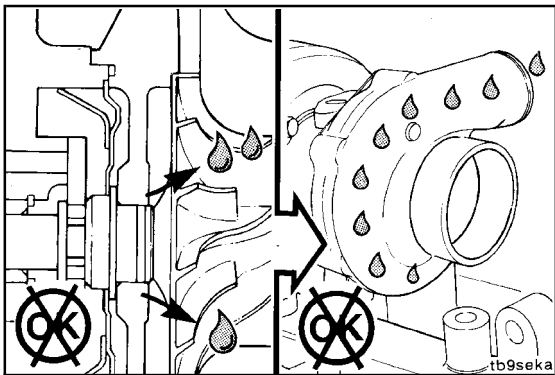

Worn or damaged seals in the turbocharger can also allow lubricating oil to leak into the air crossover pipe and be burned in the engine.

The condition can be verified by removing the air crossover tube or charge air cooler tubing and looking for oil.

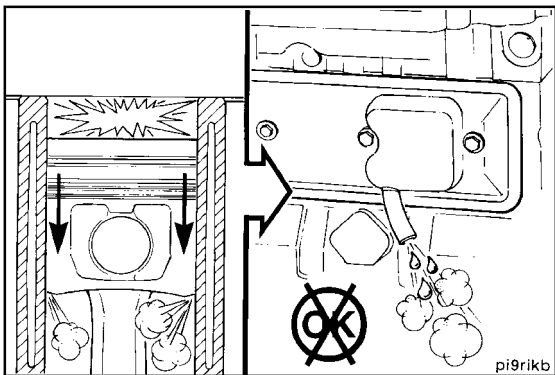

Inadequate sealing of the piston rings will result in lubricating oil being blown out the breather tube and/or consumed by the engine. Refer to Procedure 001-047 or 003-018.

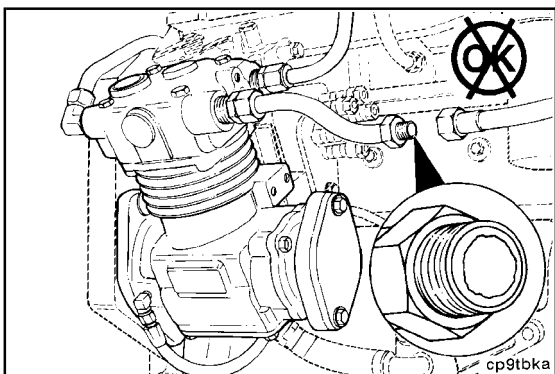

Lubricating oil can also be lost through a worn or malfunctioning air compressor. Look for carbon buildup in the air line from the compressor to the air tank. Also, a failed air compressor head or head gasket can allow oil to leak into the coolant or coolant to leak into the oil during hot shutdown. Refer to Procedure 012-003.



### Lubricating Oil Pressure Sensor, OEM (007-052)

#### Remove (007-052-002)

Disconnect the wire from the sending unit.

**NOTE:** The sending units illustrated can be different from those installed by the equipment manufacturer.

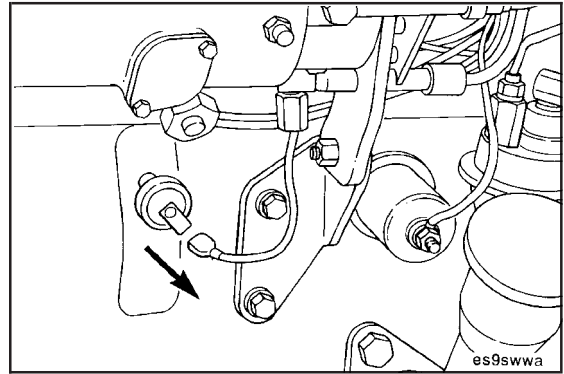

#### Inspect for Reuse (007-052-007)

Remove the lubricating oil pressure switch, install a gauge, start the engine, and measure the lubricating oil pressure. Minimum lubricating oil pressure:

Low Idle (675 to 725 rpm) 69 kPa [10 psi]

High Idle 207 kPa [30 psi]

**NOTE:** The Pressure switch is set to actuate when oil pressure drops to 55 kPa [8 psi].

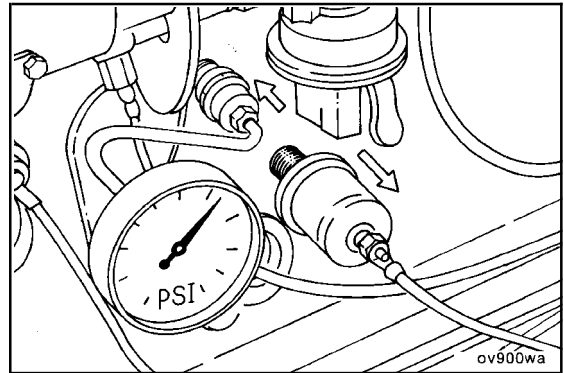

#### Install (007-052-026)

Install the sending unit.

Connect the wire to the sending unit.

#### Torque Value:

(Installed into Cast Iron)	16 N•m	[142 in-lb]
(Installed into Aluminum)	10 N•m	[89 in-lb]

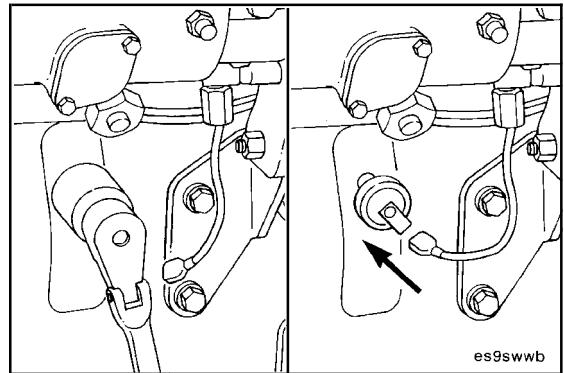





## Section 8 - Cooling System - Group 08

### Section Contents

	Page
<b>Coolant Heater</b> .....	8-6
Clean .....	8-7
General Information .....	8-6
Install .....	8-8
Maintenance Check.....	8-7
Preparatory .....	8-7
Remove.....	8-7
<b>Coolant Temperature Sensor, OEM</b> .....	8-57
Inspect for Reuse .....	8-57
Install .....	8-58
Preparatory.....	8-57
Remove.....	8-57
<b>Coolant Thermostat</b> .....	8-9
Clean .....	8-12
General Information .....	8-9
Inspect for Reuse .....	8-12
Install .....	8-13
Preparatory .....	8-11
Remove .....	8-11
Test .....	8-12
<b>Coolant Thermostat Housing</b> .....	8-14
General Information .....	8-14
<b>Cooling System</b> .....	8-14
Clean .....	8-16
Drain .....	8-15
Fill.....	8-18
Initial Check .....	8-14
Pressure Test .....	8-17
<b>Cooling System - Air or Combustion Gas Test</b> .....	8-19
Combustion Gas Leak .....	8-21
Overflow Method .....	8-19
<b>Cooling System - General Information</b> .....	8-2
<b>Cooling System Diagnostics</b> .....	8-25
General Information .....	8-25
<b>Drive Belt, Cooling Fan</b> .....	8-6
Inspect for Reuse .....	8-6
Install .....	8-6
Remove.....	8-6
<b>Fan Belt Tensioner</b> .....	8-58
Install .....	8-59
Preparatory.....	8-58
Remove.....	8-58
<b>Fan Clutch, Electric</b> .....	8-32
General Information .....	8-32
Install .....	8-34
Remove .....	8-33
<b>Fan, Cooling</b> .....	8-38
General Information .....	8-38
Inspect for Reuse .....	8-39
Install .....	8-39
Remove.....	8-38
<b>Fan Hub, Belt Driven</b> .....	8-35
Install .....	8-36
Preparatory.....	8-35
Remove.....	8-36
<b>Fan Shroud Assembly</b> .....	8-36

	Page
Initial Check .....	8-36
<b>Fan Spacer and Pulley</b> .....	8-37
Install .....	8-37
Preparatory.....	8-37
Remove.....	8-37
<b>Flow Diagram, Cooling System</b> .....	8-3
<b>Radiator</b> .....	8-40
General Information .....	8-40
Initial Check .....	8-40
<b>Radiator Hoses</b> .....	8-41
Inspect for Reuse .....	8-41
<b>Radiator Pressure Cap</b> .....	8-41
General Information .....	8-41
Inspect for Reuse .....	8-42
Pressure Test .....	8-43
<b>Radiator Shutter Assembly</b> .....	8-43
General Information .....	8-43
<b>Sea Water Heat Exchanger</b> .....	8-44
Flush.....	8-44
<b>Sea Water Pump</b> .....	8-50
Assemble .....	8-53
Clean .....	8-52
Disassemble.....	8-52
General Information .....	8-50
Inspect .....	8-51
<b>Service Tools</b> .....	8-1
Cooling System .....	8-1
<b>Specifications</b> .....	8-4
Cooling System .....	8-4
<b>Water Pump</b> .....	8-53
Clean .....	8-54
Inspect for Reuse .....	8-55
Install .....	8-55
Preparatory.....	8-53
Remove.....	8-54

## Service Tools Cooling System

The following special tools are recommended to perform procedures in this section. The use of these tools is shown in the appropriate procedure. These tools can be purchased from your local Cummins Authorized Repair Location.

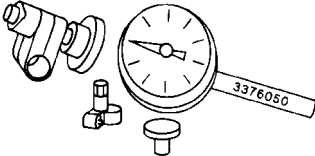
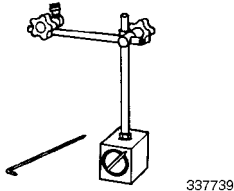
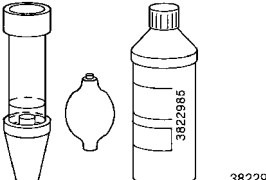
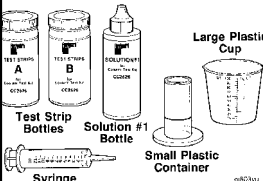
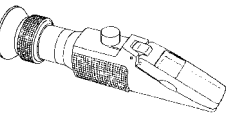
Tool No.	Tool Description	Tool Illustration
3376050	<p><b>Dial Indicator and Sleeve Assembly</b> Use with magnetic base, Part No. 3377399, to measure the fan hub and clearance.</p>	
3377399	<p><b>Magnetic Base Dial Indicator Holder</b> Used with Part No. 3376050, dial indicator and sleeve assembly.</p>	
3822985	<p><b>Combustion Gas Leak Test Kit</b> Includes Part No. 3822986, test fluid; Part No. 3822987, adapter; and Part No. 3877612, instructions.</p>	
CC-2626	<p><b>Cooling System Test Kit</b> The Fleetguard® coolant test kit is used to inspect the concentration of coolant additives in the cooling system.</p>	
CC-2800	<p><b>Refractometer</b> The Fleetguard® refractometer is used to measure the freezing point protection and antifreeze concentration.</p>	

### Cooling System - General Information

The function of the coolant system is to maintain a specified operating temperature for the engine. Some of the heat generated by the engine is absorbed by the coolant flowing through the passages in the cylinder block and head. Heat is then removed from the coolant as it flows through the radiator.

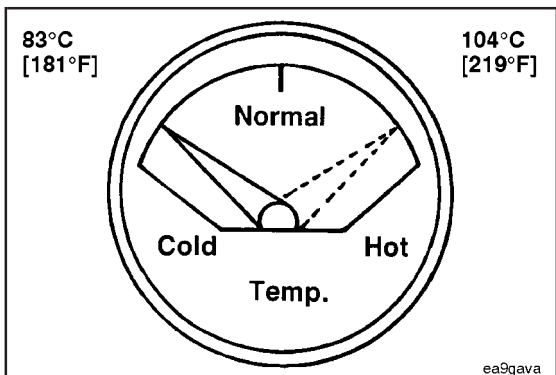

### Flow Diagram, Cooling System

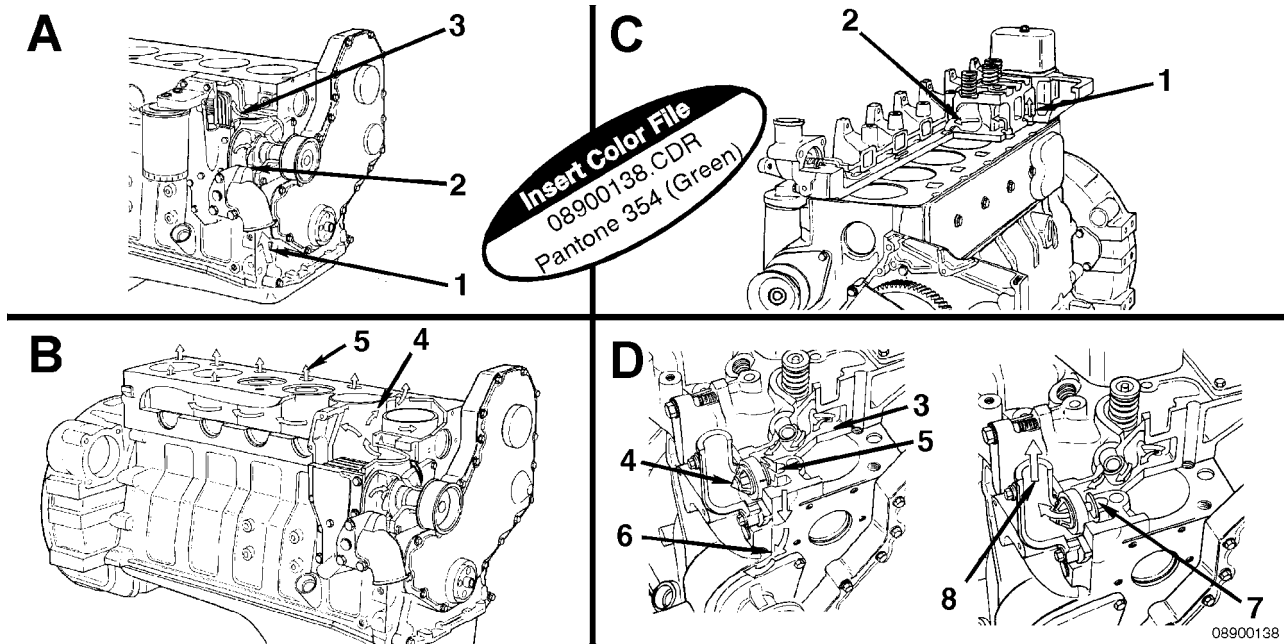

**▲ CAUTION ▲**

**Never operate the engine without a thermostat. Without a thermostat, the coolant will not flow to the radiator and the engine will overheat.**

The illustration identifies the significant features of the coolant system.

**Sections A and B.**

Coolant is drawn from the radiator by the integrally mounted water pump. The output from the water pump empties into the oil cooler cavity of the cylinder block.

The coolant then circulates around each cylinder and crosses the block to the fuel pump side of the engine.

- 1. Coolant Inlet
- 2. Pump Impeller
- 3. Coolant Flow Past Oil Cooler
- 4. Coolant Flow Past Cylinder Head
- 5. Coolant to Cylinder Head

**Sections C and D.**

Coolant then flows up into the cylinder head, crosses over the valve bridges, and down the exhaust manifold side of the engine to the integral thermostat housing.

As the coolant flows across the head toward the thermostat housing, it provides cooling for the injector. When the engine is below operating temperature, the thermostat is closed, and the coolant flow bypasses the radiator and goes to the water pump inlet through internal drillings in the block and cylinder head.

- 1. Coolant Flow from the Cylinder Head
- 2. Coolant to the Thermostat Housing
- 3. Coolant Flow Past Injector
- 4. Thermostat
- 5. Coolant Bypass Passage
- 6. Coolant Flow to Pump Inlet
- 7. Bypass Closed
- 8. Coolant Flow Back to Radiator

When operating temperature is reached, the thermostat opens, blocking the bypass passage to the water pump and opening the outlet to the radiator.

## Specifications

### Cooling System

#### Cooling System Data (automotive)

	B3.9	B5.9
Coolant Capacity (engine <b>only</b> )	7 liters [7.4 qt]	10.5 liters [11.1 qt]
Standard Modulating Thermostat Range	Start 83°C [181°F]	Fully Open 95°C [203°F]
Pressure Cap:		
104°C [220°F] Systems	103 kPa [15 psi]	103 kPa [15 psi]
99°C [210°F] Systems	48 kPa [7 psi]	48 kPa [7 psi]

**4B Cooling System Data (nonautomotive)**

	<b>4B3.9</b>	<b>4BT3.9</b>	<b>4BTA3.9</b>
Coolant Capacity (engine <b>only</b> )	7 liters [7.4 qt]	7 liters [7.4 qt]	9.7 liters [10.2 qt]
Standard Modulating Thermostat Range	Start 83°C [181°F]; Fully Open 95°C [203°F]	Start 83°C [181°F]; Fully Open 95°C [203°F]	Start 83°C [181°F]; Fully Open 95°C [203°F]
Pressure Cap:			
104°C [220°F] Systems	103 kPa [15 psi]	103 kPa [15 psi]	103 kPa [15 psi]
99°C [210°F] Systems	48 kPa [7 psi]	48 kPa [7 psi]	48 kPa [7 psi]

**6B Cooling System Data (nonautomotive)**

	<b>6B5.9</b>	<b>6BT5.9</b>	<b>6BTA5.9</b>
Coolant Capacity (engine <b>only</b> )	10.5 liters [11.1 qt]	10.5 liters [11.1 qt]	14.5 liters [15.3 qt]
Standard Modulating Thermostat Range	Start 83°C [181°F]; Fully Open 95°C [203°F]	Start 83°C [181°F]; Fully Open 95°C [203°F]	Start 83°C [181°F]; Fully Open 95°C [203°F]
Pressure Cap:			
104°C [220°F] Systems	103 kPa [15 psi]	103 kPa [15 psi]	103 kPa [15 psi]
99°C [210°F] Systems	48 kPa [7 psi]	48 kPa [7 psi]	48 kPa [7 psi]



### Drive Belt, Cooling Fan (008-002)

#### Remove (008-002-002)



#### 3/8-Inch Square Drive

Lift the tensioner to remove the drive belt.

**NOTE:** The belt tensioner is spring-loaded and **must** be pivoted away from the drive belt. Pivoting in the wrong direction can result in damage to the belt tensioner.

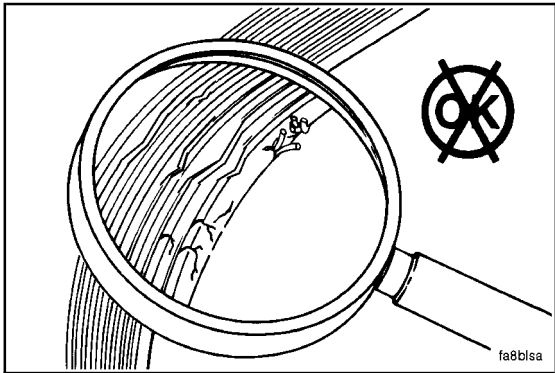

#### Inspect for Reuse (008-002-007)

Inspect the belt for:

- Cracks
- Glazing
- Tears or cuts
- Excessive wear.

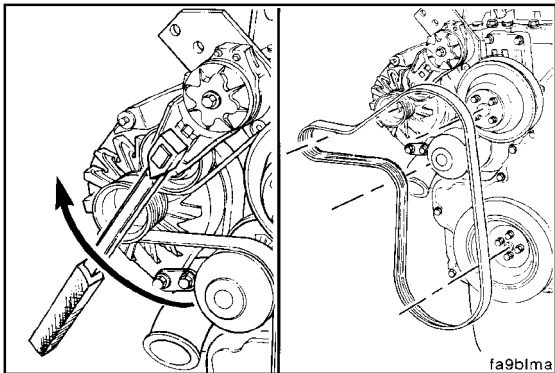

#### Install (008-002-026)

#### 3/8-Inch Square Drive

Lift and hold the belt tensioner. Install the drive belt, and release the tensioner.

**NOTE:** The belt tensioner is spring-loaded and **must** be pivoted away from the drive belt. Pivoting in the wrong direction can result in damage to the belt tensioner.

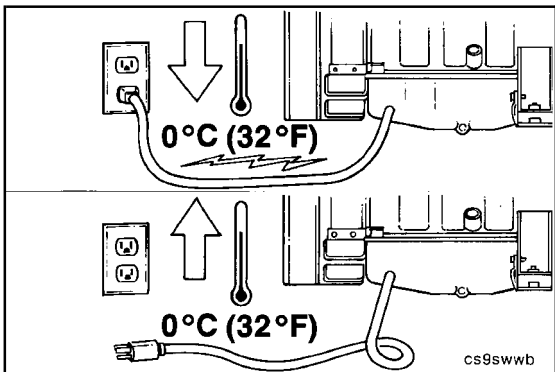

### Coolant Heater (008-011)

#### General Information

Some heaters will operate continuously when plugged into the correct voltage electrical socket. Operate them **only** when the ambient temperature is below 0°C [32°F].



**Maintenance Check (008-011-008)**

When operating, the engine block or oil pan heater should make a sound and the adjacent parts should be warm to the touch.

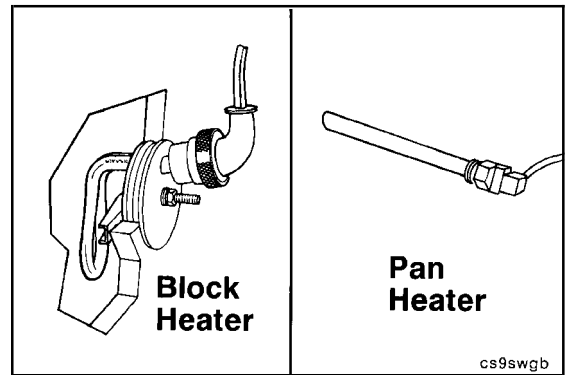

**Preparatory (008-011-000)**



Coolant is toxic. If not reused, dispose of in accordance with local environmental regulations.

**Cylinder Block Water Heater**

- Drain at least 19 liters [5 gal] of coolant. Refer to Procedure 008-018.

Disconnect the block heater electrical cord.

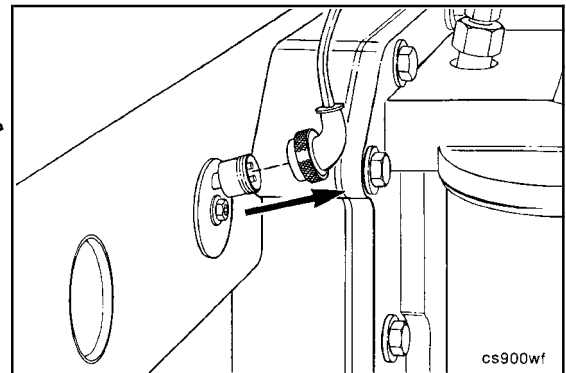

**Remove (008-011-002)**

10 mm

Loosen the block heater retaining nut.

Remove the block heater from the block.

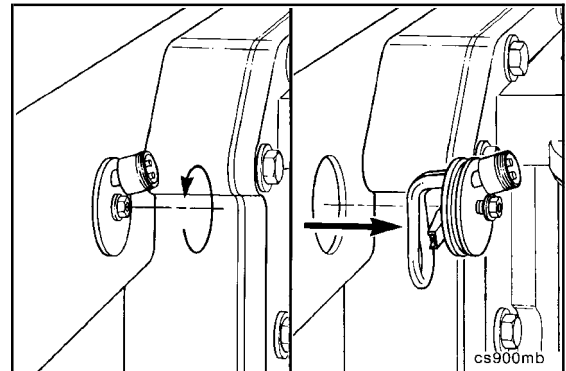

**Clean (008-011-006)**

Clean the core plug hole thoroughly. Make sure there are no burrs or sharp edges that can cut the o-ring.

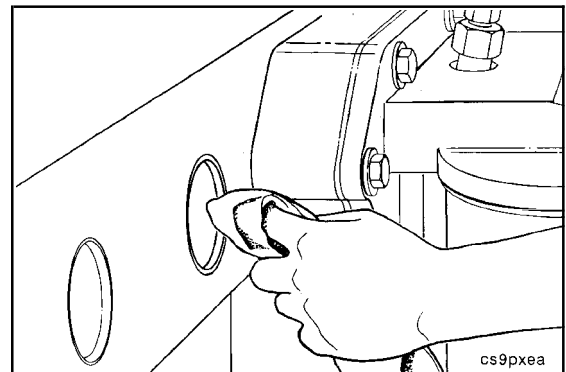

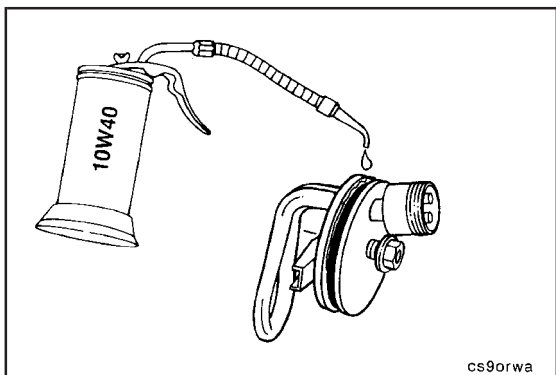

**Install (008-011-026)**

Lubricate the new heater o-ring with clean lubricating engine oil.

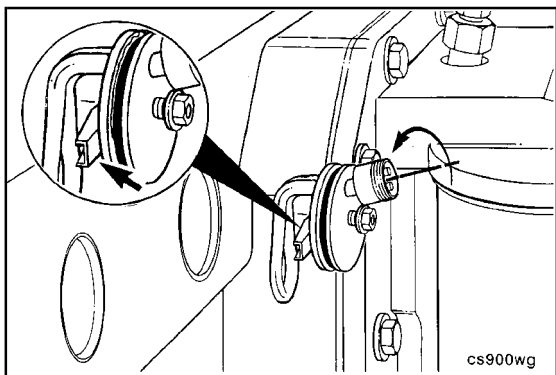

The locking channel (T-bar) should be threaded out to the end of the bolt. If so equipped, do **not** remove the retaining wire used to position the channel (T-bar).

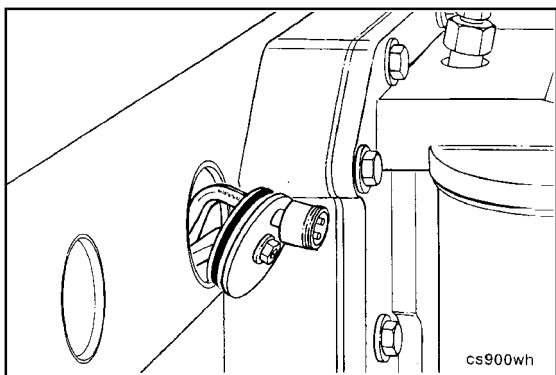

Hook the element and one leg of the channel (T-bar) into the hole as illustrated.

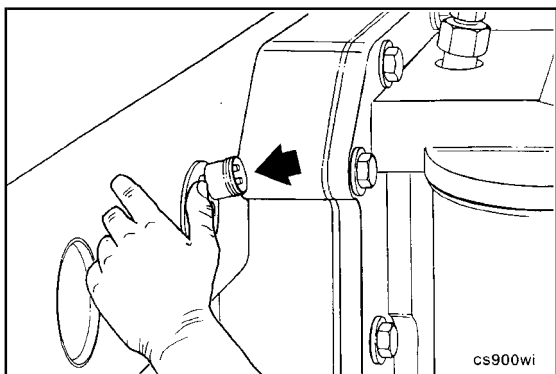

Hook the other leg of the channel in the hole, and push the heater into the hole as far as possible by hand.

**⚠ CAUTION ⚠**

Do not pull the heater into location with the locking bolt as the channel (T-Bar) can bend or cause the threads to strip.

**Plastic Hammer**

If necessary, use a plastic hammer to tap the heater in until the shoulder contacts the block.

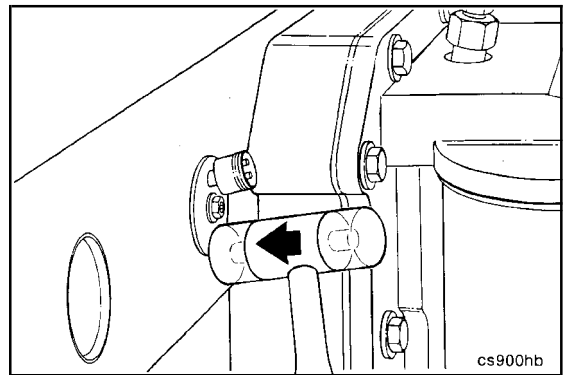

**10 mm Socket, Inch lb. Torque Wrench**

**Torque Value:**

Minimum:	1.3 N•m	[12 in-lb]
Maximum:	2.8 N•m	[25 in-lb]

**NOTE:** Do not overtighten.

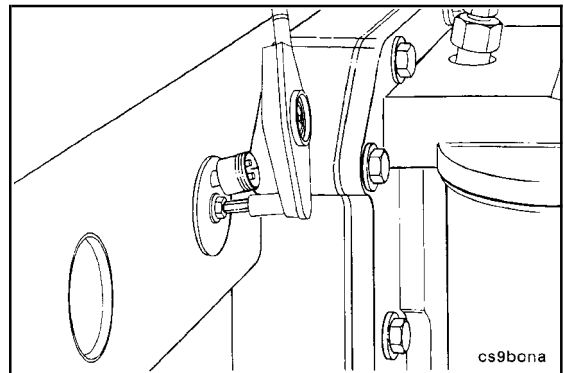

Insert the power cord into the socket being careful to align the pins with the sockets of the power cord. Tighten the retaining nut by hand.

Do not apply power until the cooling system is filled, and has run long enough for the thermostat to open and allow the air to escape.

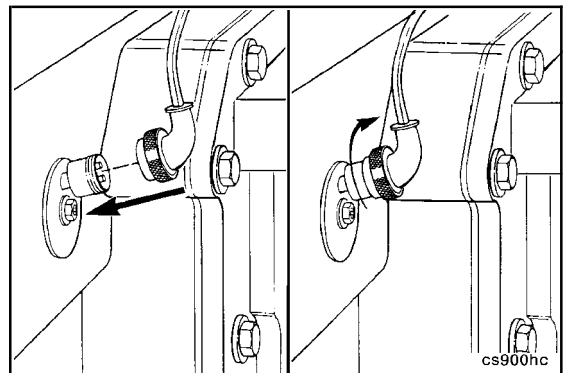

**Coolant Thermostat (008-013)**

**General Information**

The thermostat controls the coolant temperature. When the coolant temperature is below the operating range, coolant is bypassed back to the inlet of the water pump. When the coolant temperature reaches the operating range, the thermostat opens, sealing off the bypass, forcing coolant to flow to the radiator.

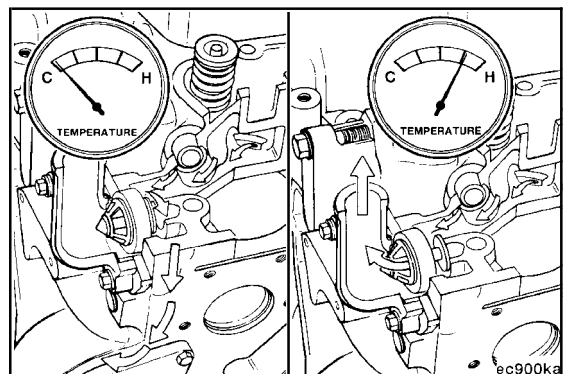

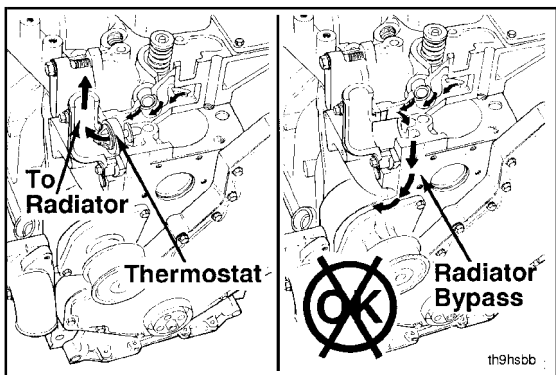

**⚠ CAUTION ⚠**

Always use the correct thermostat, and never operate the engine without a thermostat installed. The engine can overheat if operated without a thermostat because the path of least resistance for the coolant is through the bypass to the pump inlet.

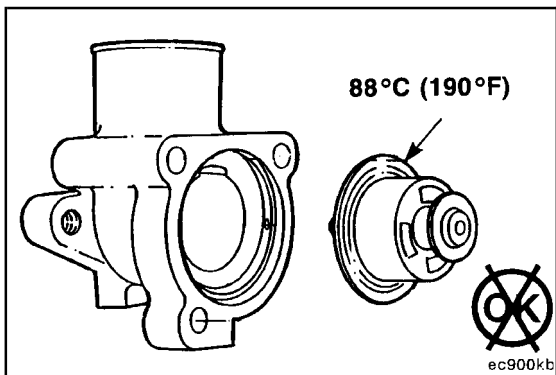

An incorrect or malfunctioning thermostat can cause the engine to overheat or run too cold.

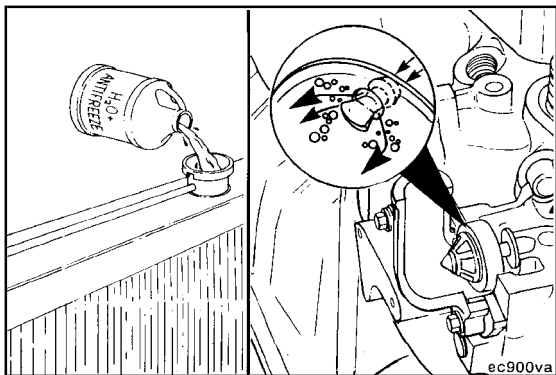

As described in the coolant discussion, jiggle pins vent air during filling of the coolant system.

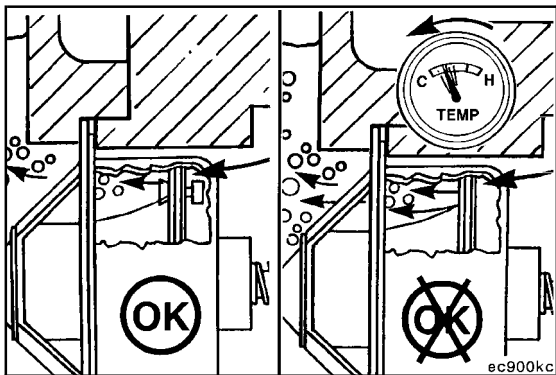

After the engine is vented and filled, the jiggle pins act as check valves to block the flow of coolant through the opening during engine operation.

With the jiggle pins sealing the openings, the flow to the radiator is controlled by the thermostat opening in response to the engine coolant temperature.

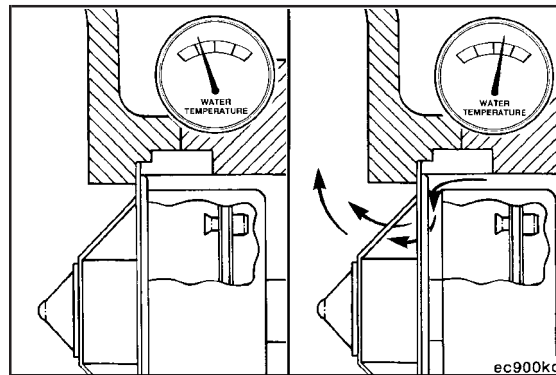

**Preparatory (008-013-000)**

- Drain the coolant. Refer to Procedure 008-018.
- Disconnect the upper radiator hose. Refer to Procedure 008-045.

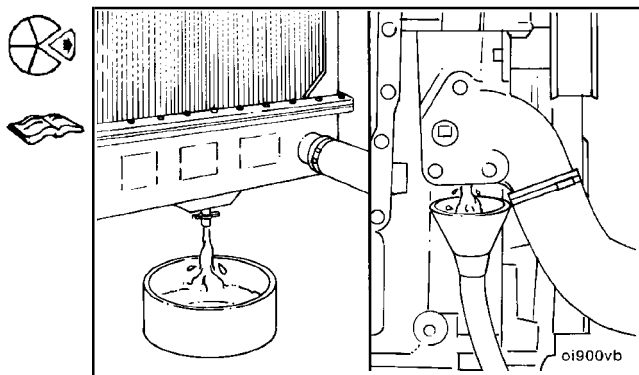

**Remove (008-013-002)**

**13 mm, 16 mm**

Remove the alternator mounting capscrew, loosen the alternator link capscrew, and lower the alternator.

Refer to Procedure 013-001.

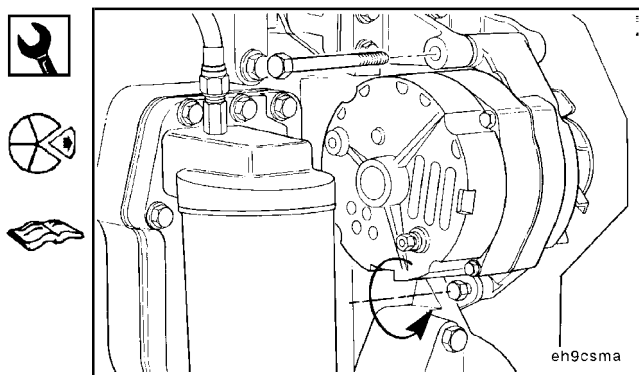

**10 mm**

Remove three capscrews, the thermostat housing, lifting bracket, thermostat, and thermostat seal.

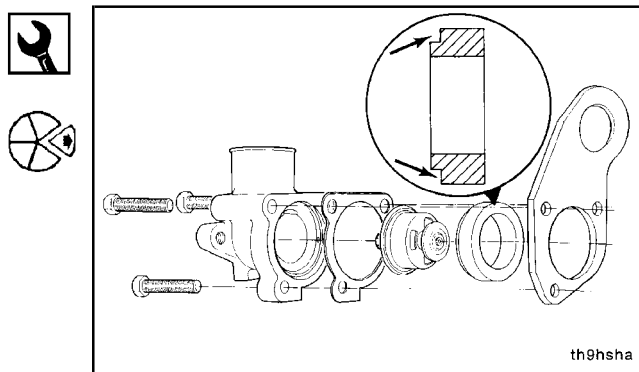

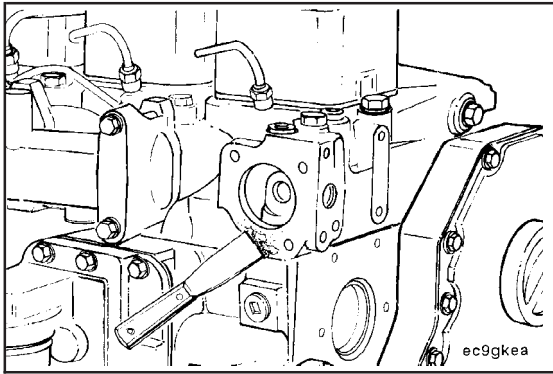

**Clean (008-013-006)**

Clean the mating surfaces.

**NOTE:** Do **not** let any debris fall into the thermostat cavity when cleaning the gasket surfaces.

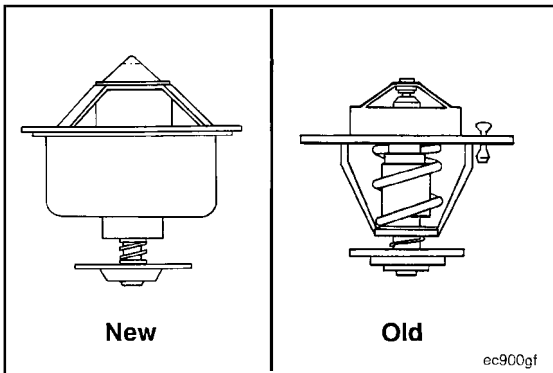

**Inspect for Reuse (008-013-007)**

Inspect the thermostat for obvious damage such as obstructions caused by debris, broken springs, or stuck or missing vent pins.



Make sure the thermostat is clean and free from corrosion.

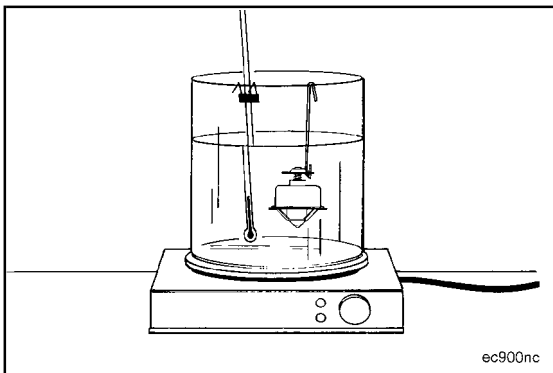

**Test (008-013-012)**

Suspend the thermostat and a 100°C [212°F] thermometer in a container of well-mixed water.

**NOTE:** Do **not** allow the thermostat or thermometer to touch the side of the container.

Heat the water slowly so the wax element in the thermostat has sufficient time to react to the rising water temperature.

Check the thermostat as follows:

**Requirements**

Starts to open within 1°C [34°F] of 83°C [181°F].

Fully open within 1°C [34°F] of 95°C [203°F].

A full-open clearance between the thermostat flow valve and flange.

Flow Valve and Flange Clearance		
mm		in
6.6	MIN	0.26

Install (008-013-026)

**⚠ CAUTION ⚠**

Always use the correct thermostat, and never operate the engine without a thermostat installed. The engine can overheat if operated without a thermostat because the path of least resistance for the coolant is through the bypass to the pump inlet. An incorrect thermostat can cause the engine to overheat or run too cold.

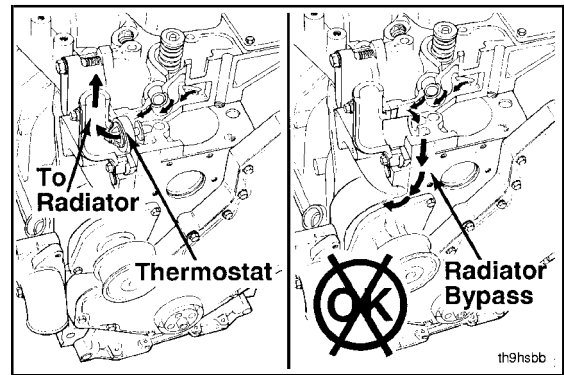

Position the thermostat as shown in the illustration.

“Package” the lifting bracket and thermostat gasket to the thermostat and thermostat housing.

Make sure the gasket is aligned with the capscrew holes. Install the capscrews and finger tighten.

The notched end of the rubber thermostat seal points away from the cylinder head.

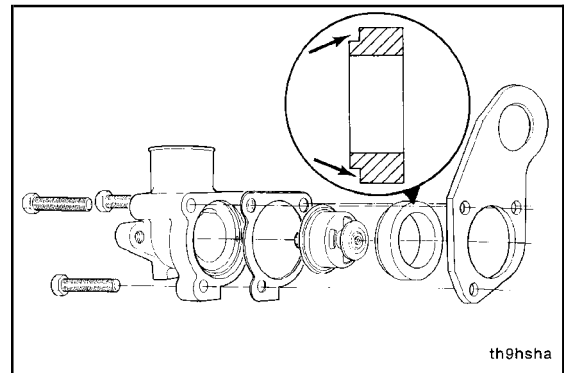

**10 mm**

Install the removed parts in the reverse order of removal.

Install the removed parts in the reverse order of removal.

Install the thermostat, thermostat seal, thermostat housing, gasket, lifting bracket, and three capscrews.

**Torque Value:** 24 N•m [18 ft-lb]

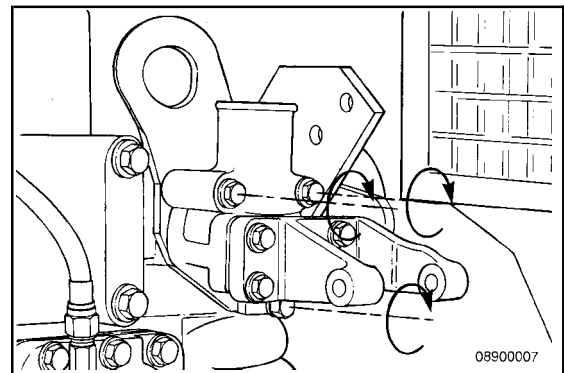

**13 mm, 16 mm**

Install the alternator. Refer to Procedure 013-001.

**Torque Value:**

(A)	24 N•m	[18 ft-lb]
(B)	43 N•m	[32 ft-lb]

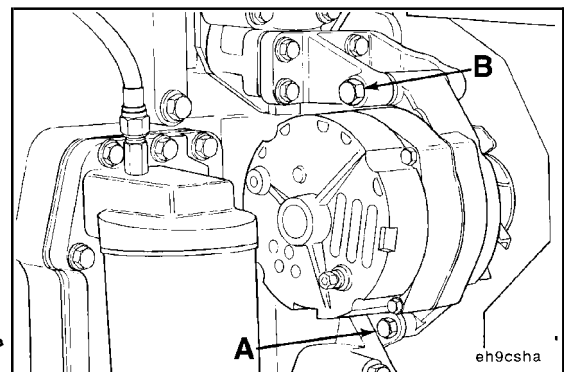



13 mm

Install the drive belt. Refer to Procedure 008-002.



**NOTE:** After the belt tensioner has been raised to remove/install the belt, check the torque of the tensioner capscrew.

**Torque Value:** 43 N•m [32 ft-lb]

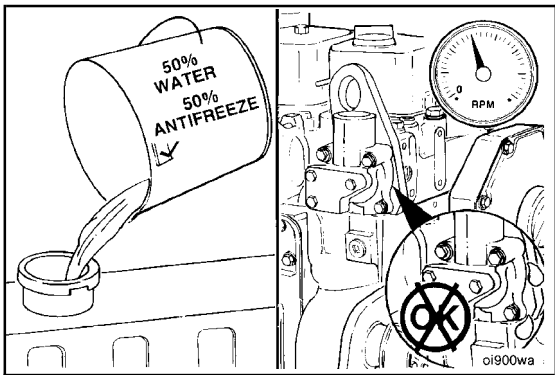

**CAUTION**

Always vent the engine and aftercooler during filling to remove air from the coolant system, or overheating will result.

Fill the cooling system. Operate the engine, and check for leaks.



### Coolant Thermostat Housing (008-014)

#### General Information

Refer to Procedure 008-013 for coolant thermostat and coolant housing.

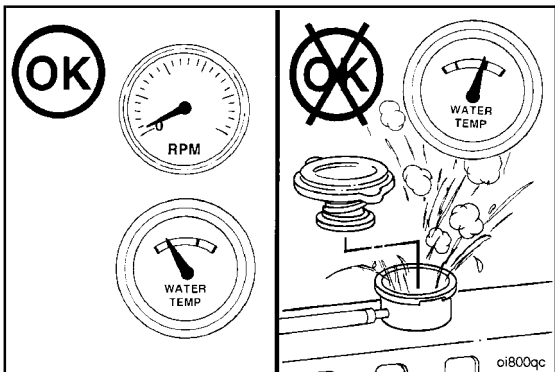

### Cooling System (008-018)

#### Initial Check (008-018-001)

**WARNING**

Do not remove the pressure cap from a hot engine. Wait until the coolant temperature is below 50°C [122°F] before removing the pressure cap. Heated coolant spray or steam can cause personal injury.

**NOTE:** Never use a sealing additive to stop leaks in the coolant system. This can result in coolant system plugging and inadequate coolant flow, causing the engine to over-heat.

The coolant level **must** be checked daily.



**⚠ CAUTION ⚠**

Do not add cold coolant to a hot engine. Engine castings can be damaged. Allow the engine to cool to below 50°C [122°F] before adding coolant.

**NOTE:** On applications that use a coolant recovery system, check to make sure the coolant is at the appropriate level on the coolant recovery tank, depending on engine temperature.

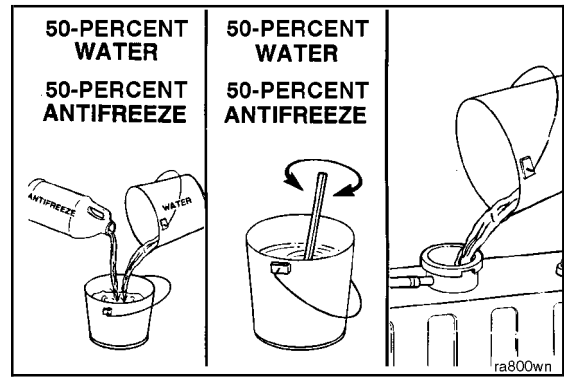

Fill the cooling system with coolant to the bottom of the fill neck in the radiator fill or expansion tank.

**NOTE:** Some radiators have two fill necks, both of which must be filled when the cooling system is drained.

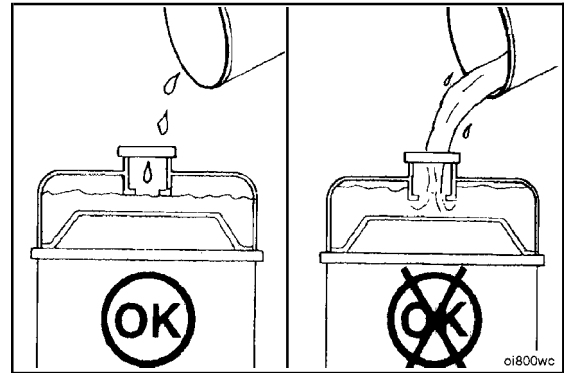

**Drain (008-018-005)**

**⚠ WARNING ⚠**

Avoid prolonged and repeated skin contact with used antifreeze. Such prolonged, repeated contact can cause skin disorders or other bodily injury. Keep out of reach of children.

**⚠ CAUTION ⚠**

Protect the environment: Handling and disposing of used antifreeze is subject to federal, state, and local regulations. Use authorized waste disposal facilities, including civic amenity sites and garages providing authorized facilities for the receipt of used antifreeze. If in doubt, contact your local authorities of the EPA for guidance as to proper handling of used antifreeze.

**⚠ WARNING ⚠**

Do not remove the pressure cap from a hot engine. Wait until the coolant temperature is below 50°C [122°F] before removing the pressure cap. Heated coolant spray or steam can cause personal injury.

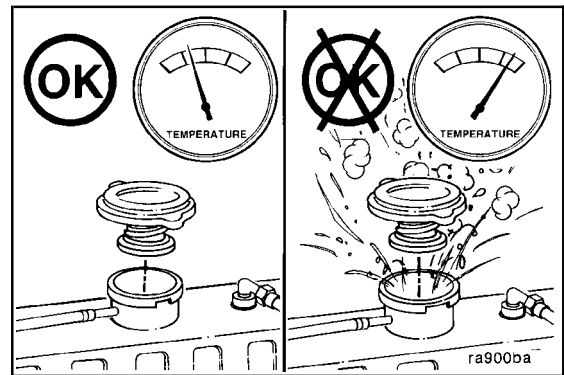

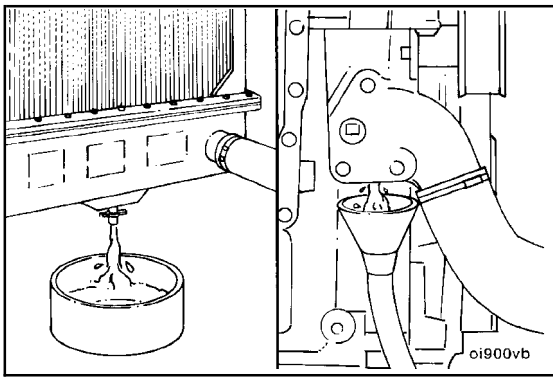

**▲ WARNING ▲**

Coolant is toxic. Keep away from children and pets. If not reused, dispose of in accordance with local environmental regulations.

Drain the cooling system by opening the drain valve on the radiator and removing the plug in the bottom of the water inlet. A drain pan with a capacity of 19 liters [5 gal] will be adequate in most applications.

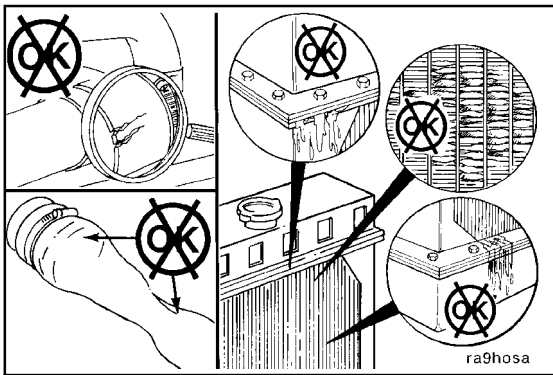

Check for damaged hoses and loose or damaged hose clamps. Replace as required. Check the radiator for leaks, damage, and buildup of dirt. Clean and replace as required.

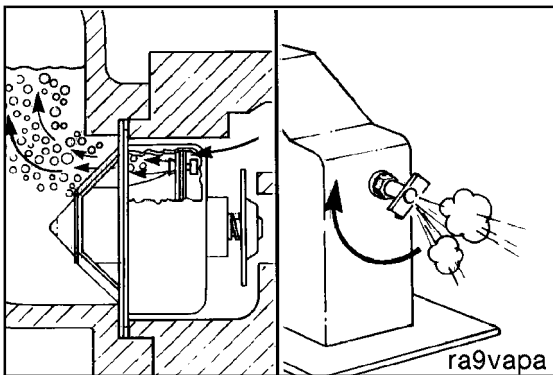

**Clean (008-018-006)**

**▲ CAUTION ▲**

During filling, air must be vented from the engine coolant passages. The air vents through the jiggle pin openings to the top radiator hose and out the fill opening. Additional venting is provided for engines equipped with an aftercooler. Open the petcock during filling.

**NOTE:** Adequate venting is provided for a fill rate of 19 liters per minute [5 U.S. gallons per minute].

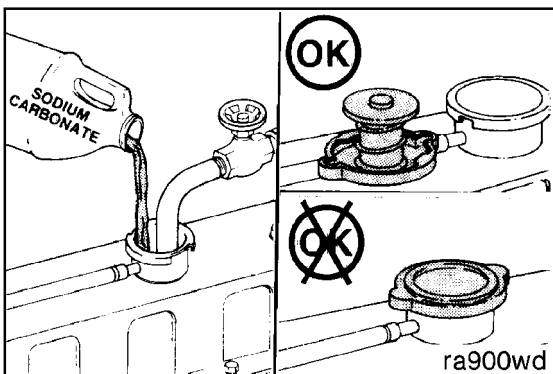

**▲ CAUTION ▲**

Do not install the radiator cap. The engine is to be operated without the cap for this process.

Fill the system with a mixture of sodium carbonate and water (or a commercially available equivalent).

**NOTE:** Adequate venting is provided for a fill rate of 19 liters per minute [5 U.S. gallons per minute].

**B3.9 and B5.9 Series Engines  
Section 8 - Cooling System - Group 08**

Operate the engine for 5 minutes with the coolant temperature above 80°C [176°F].

Shut the engine off, and drain the cooling system.

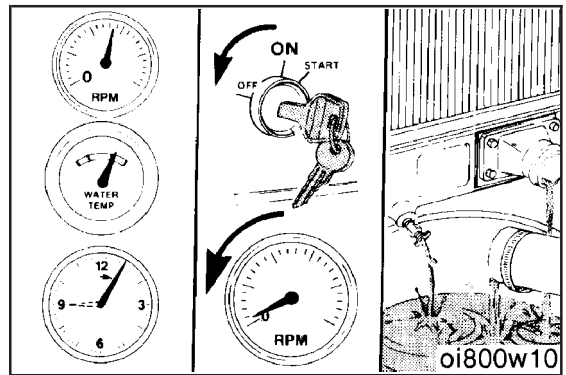

Fill the cooling system with clean water.

**NOTE:** Be sure to vent the engine and aftercooler for complete filling.

**NOTE:** Do **not** install the radiator cap or the new coolant filter.

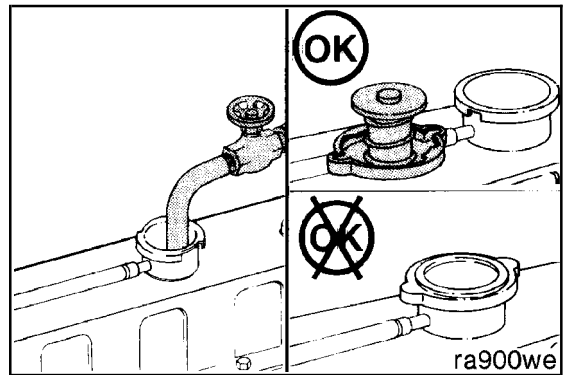

Operate the engine for 5 minutes with the coolant temperature above 80°C [176°F].

Shut the engine off, and drain the cooling system.

**NOTE:** If the water being drained is still dirty, the system **must** be flushed again until the water is clean.

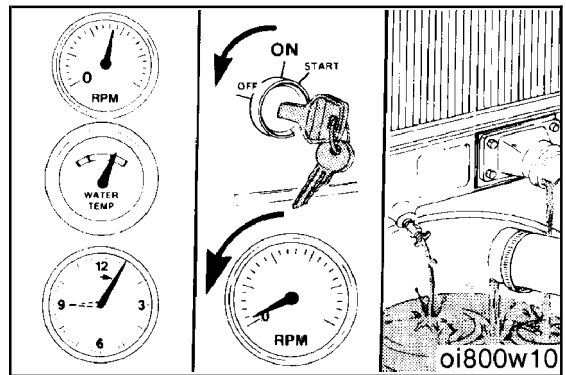

**Pressure Test (008-018-013)**

The system is designed to use a pressure cap to prevent boiling of the coolant.

Different caps are specified for the two recommended systems:

	Radiator Cap Pressure Test	
	System	Cap
A-Normal-Duty	104°C [219°F]	103 kPa [15 psi]
B-Light-Duty	99°C [210°F]	48 kPa [7 psi]

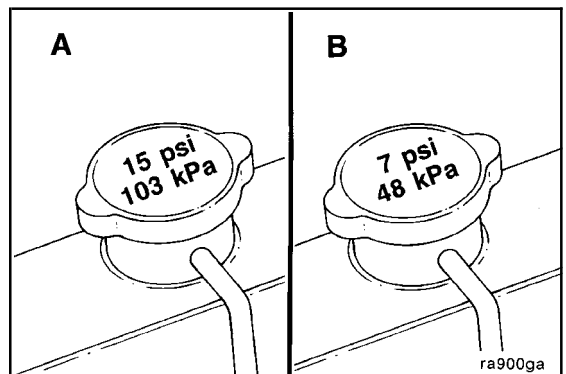

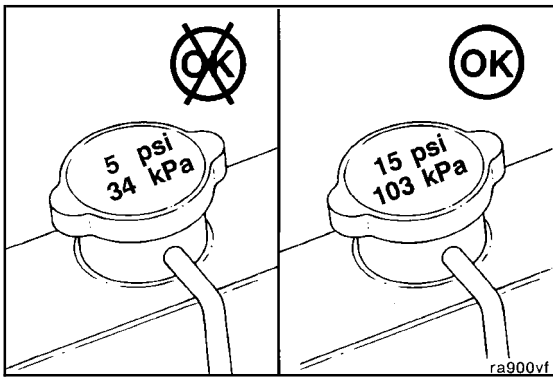

An incorrect or malfunctioning cap can result in the loss of coolant and the engine running hot.

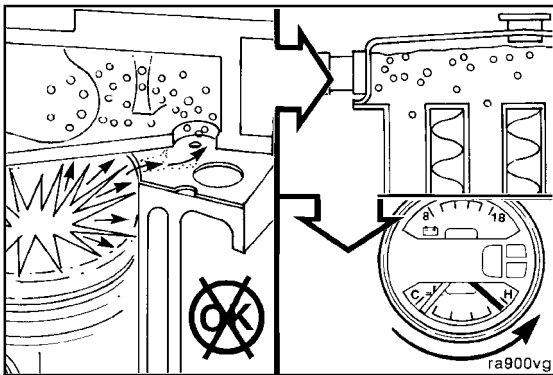

Air in the coolant can result in loss of coolant from the overflow when the aerated coolant is hot. The heated air expands, increasing the pressure in the system, causing the cap to open.

Similarly, coolant can be displaced through the overflow if the head gasket leaks compression gases to the coolant system.

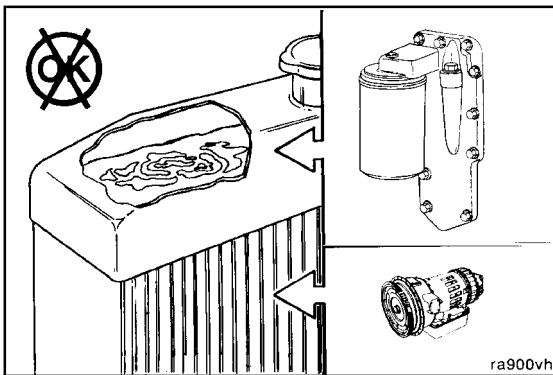

The operating pressure of the coolant system and the lubricating system can result in the mixing of the fluids if there is a leak between the systems: head gasket, oil cooler, etc. (Refer to Section 7-Lubricating Oil System.)



**NOTE:** Transmission fluid can also leak into the coolant through radiator bottom tank transmission oil coolers. Refer to the OEM service manual.

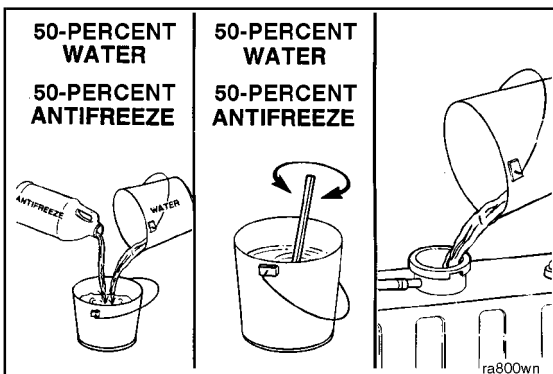

**Fill (008-018-028)**

**CAUTION**

**Never use water alone for coolant. Damage from corrosion can be the result of using water alone for coolant.**

**NOTE:** A 50-percent mixture of antifreeze and water **must** be premixed before filling the system. The ability of antifreeze to remove heat from the engine is **not** as good as water, so pouring antifreeze into the engine first could contribute to an overheated condition before the liquids are completely mixed.

**⚠ CAUTION ⚠**

The system must be filled slowly to prevent air locks. During filling, air must be vented from the engine coolant passage. The system has a fill rate of 14 liters per minute [3.7 gallons per minute]. Do not exceed this fill rate. Wait 2 to 3 minutes to allow air to be vented; then add coolant to bring the level to the top.

Close all drain valves and fill the system. Use a mixture of 50-percent water and 50-percent ethylene glycol antifreeze to provide freeze protection to -36°C [-33°F].

**Coolant Capacity (engine only)**

	liters		U.S.gal
4B3.9, 4BT3.9	7	MAX	1.85
4BTA3.9	7.9	MAX	2.1
6B5.9, 6BT5.9	9	MAX	2.38
6BTA5.9	9.9	MAX	2.61

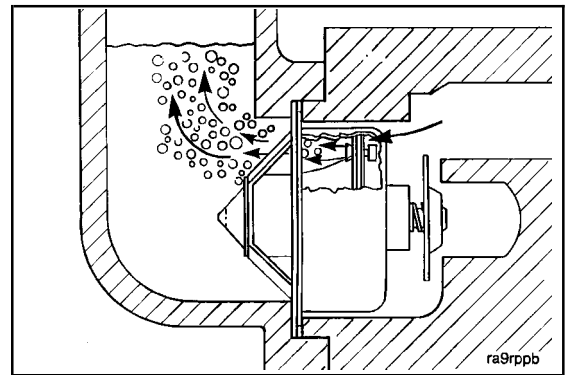

**⚠ WARNING ⚠**

Do not remove the pressure cap from a hot engine. Wait until the coolant temperature is below 50°C [122°F] before removing the pressure cap. Heated coolant spray or steam can cause personal injury.

Install the pressure cap. Operate the engine until it reaches a temperature of 80°C [176°F], and check for coolant leaks.

Check the coolant level again to make sure the system is full of coolant or that the coolant level has risen to the hot level in the recovery bottle on the system, if so equipped.

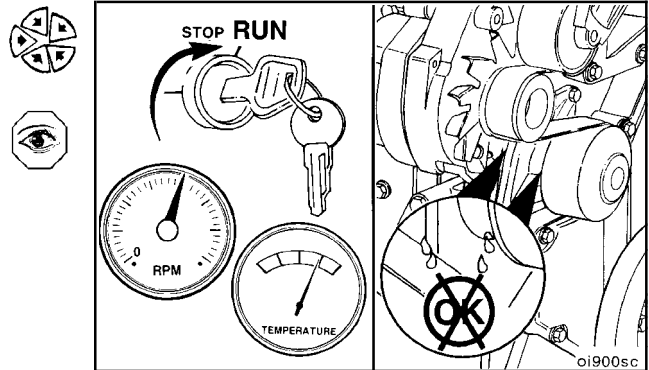

**Cooling System - Air or Combustion Gas Test (008-019)**

**Overflow Method**

**⚠ WARNING ⚠**

Do not remove the pressure cap from a hot engine. Wait until the coolant temperature is below 50°C [122°F] before removing the pressure cap. Heated coolant spray or steam can cause personal injury.

**Air in Cooling System**

Allow the engine to cool, and remove the radiator cap.

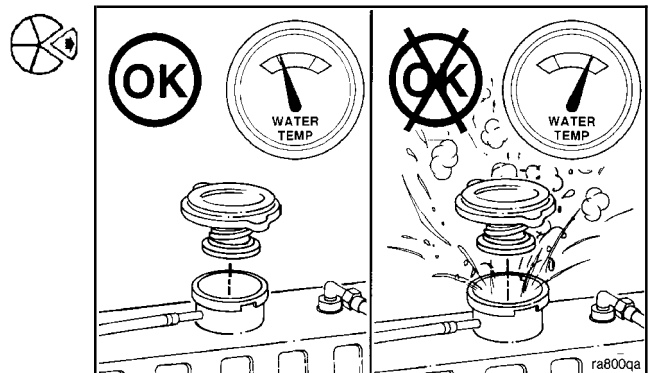

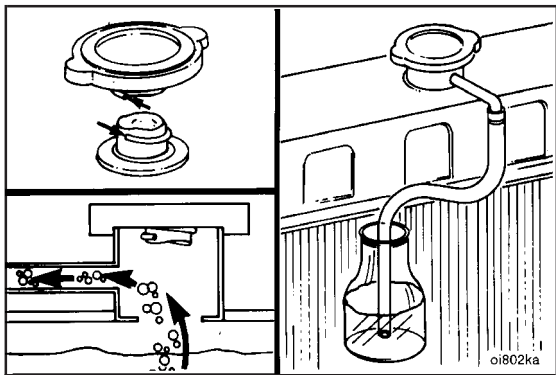

**NOTE:** The pressure cap **must** make a tight seal.  
Install a radiator pressure cap that has had the spring and pressure relief valve removed.  
Attach a rubber hose to the radiator overflow connection.  
Place the free end of the hose in a container of water.

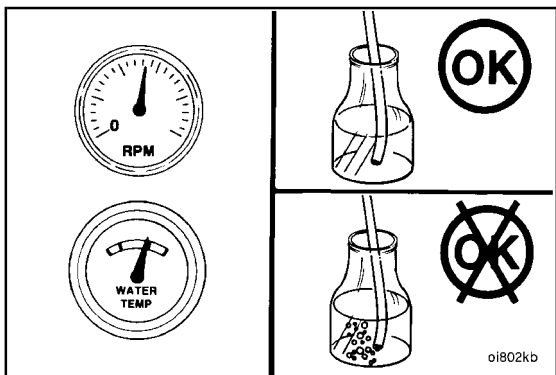

Operate the engine at rated rpm until it reaches a temperature of 80°C [176°F] with the thermostat open.  
Check for a continuous flow of air bubbles from the hose in the water container.

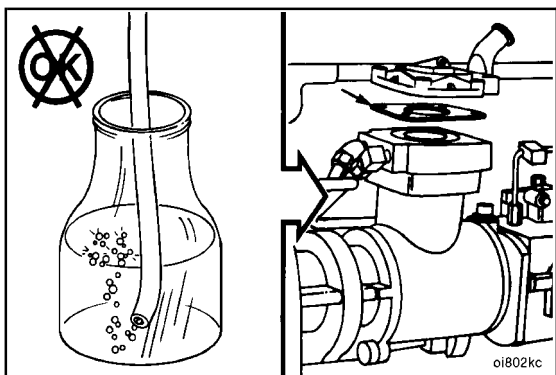

A continuous flow of air bubbles can be caused by one of the following:

- Fan, shutter, or heater air control thermostat valve leaking air.
- An air compressor cylinder head leak. Refer to Procedure 012-019 for air compressor leak test.

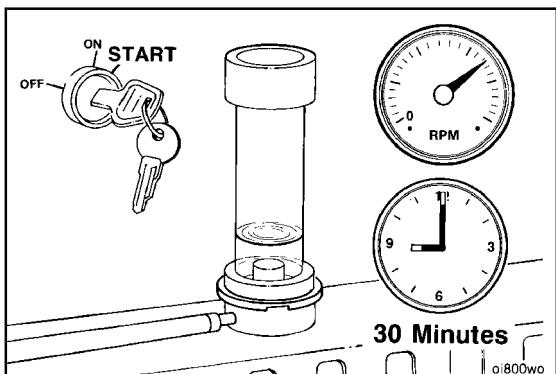

If one of the air control valves or the air compressor was **not** the source of air entering the cooling system, perform the Combustion Gas Leak test.

If no air is found in the cooling system, do the following:

- Remove the test equipment.
- Check the coolant level, and fill if necessary.
- Install the radiator pressure cap.
- Operate the engine until it reaches a temperature of 80°C [176°F], and check for coolant leaks.

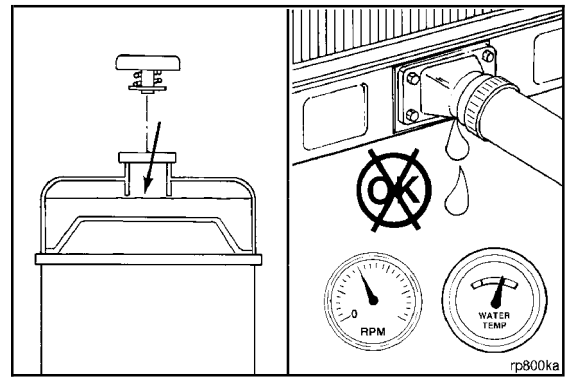

**Combustion Gas Leak**

**Fan, Shutter, or Heater Air Control Valve**

**⚠ CAUTION ⚠**

The engine can overheat with the fan control or the shutter air control valve disconnected. Monitor the engine coolant temperature while performing this test. The coolant temperature must not exceed 100°C [212°F].

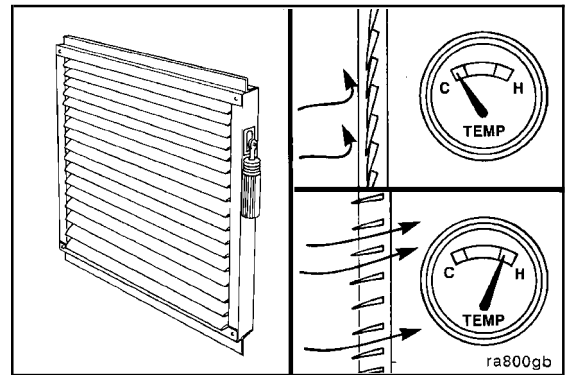

Repeat the test for air in the cooling system as previously described in Procedure 008-019. If no air is found in the cooling system with the air control valve(s) isolated, install a new control valve.

**NOTE:** Start the engine, and run for 5 minutes before testing for air in the coolant. This will allow any trapped air to purge from the system.

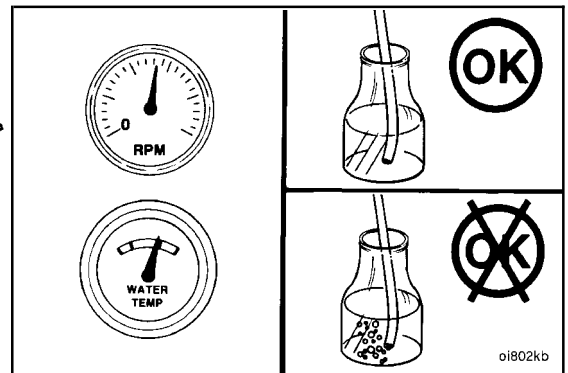

**Air Compressor**

**⚠ CAUTION ⚠**

The air compressor discharge line must be disconnected at the compressor to allow the compressor to discharge air to the atmosphere to prevent the compressor from overheating during this next test. Do not run the engine over 5 minutes with components isolated from the cooling system. Component damage can occur.

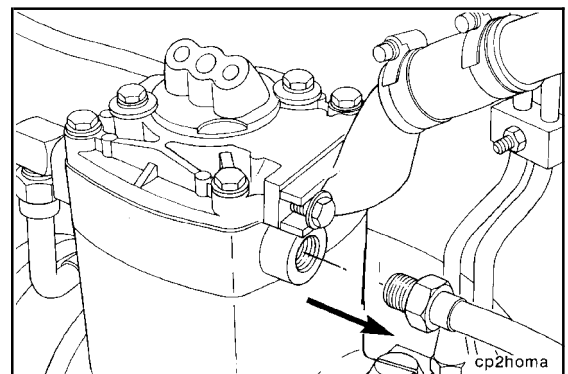

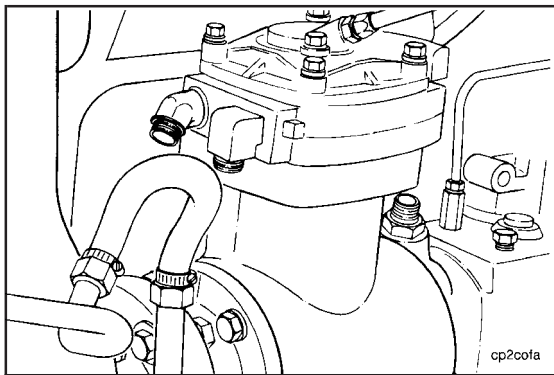

Disconnect the coolant supply and the return tubes from the air compressor. Use a short piece of hose to connect the tubes together to prevent coolant loss during engine operation.

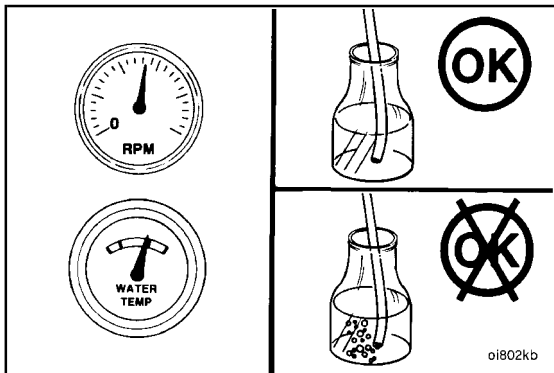

Repeat the test for air in the cooling system as previously described in Procedure 008-019. If no air is found in the cooling system with the air compressor isolated, repair or replace the air compressor. Refer to Procedure 012-014.

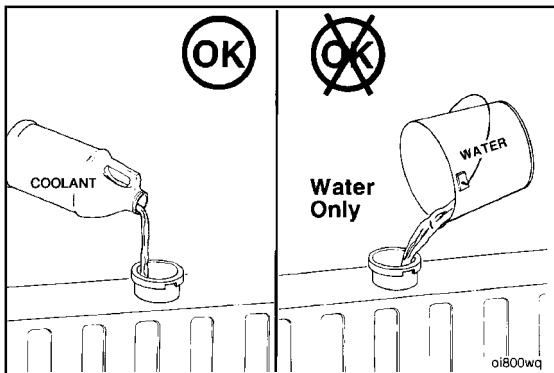

**Combustion Gas Leak Test Kit, Part No. 3822985**

Use combustion gas leak test kit, Part No. 3822985, or equivalent, to test for combustion gases in the cooling system.

It is recommended that the cooling system contain a mixture of 50-percent antifreeze and 50-percent water during the combustion gas leak test. The use of water **only** can result in a color change in the test fluid from blue to turquoise or light green during the test. This is **not** an indication of a combustion gas leak.

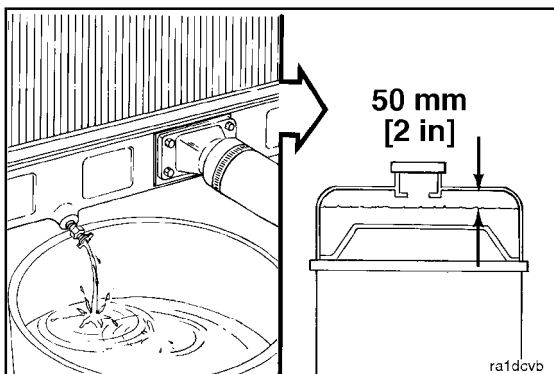

Drain the coolant level down approximately 50 mm [2 in] below the radiator cap seal ledge in the radiator fill neck.



Pour the test fluid into the combustion gas leak test instrument until it is up to the yellow fill line on the instrument.

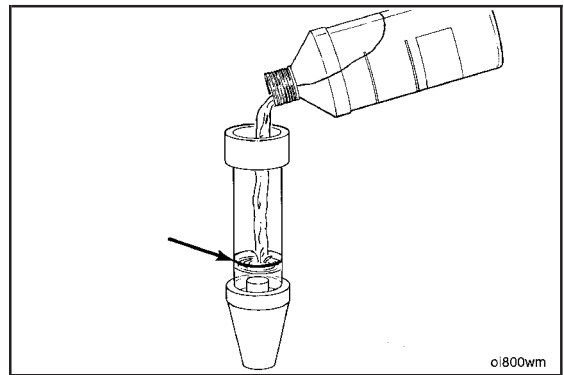

o1800wm

Insert the rubber tip of the combustion gas leak test instrument in the radiator fill neck. Hold the instrument down firmly while turning back and forth to make sure that an air tight seal is formed between the tester and radiator fill neck.

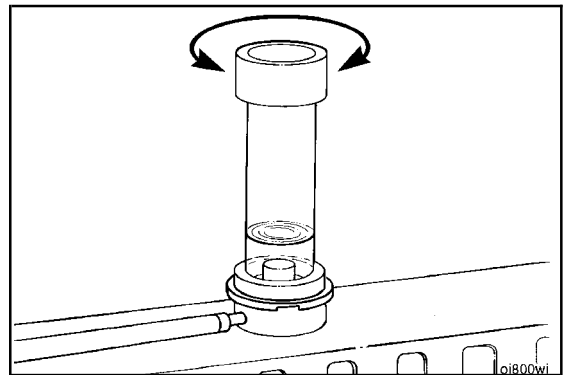

o1800wi

Start the engine, and run at high idle for approximately 30 minutes. Monitor the engine temperature and color of the test fluid during engine operation. Do **not** allow the engine temperature to exceed 100°C [212°F] during the test.

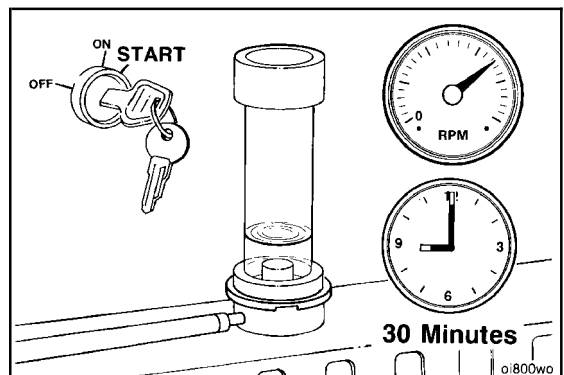

o1800wo

If the color of the test fluid changes from blue to yellow anytime during the test, combustion gases are leaking into the cooling system. Discontinue the test if the color of test fluid changes from blue to yellow.

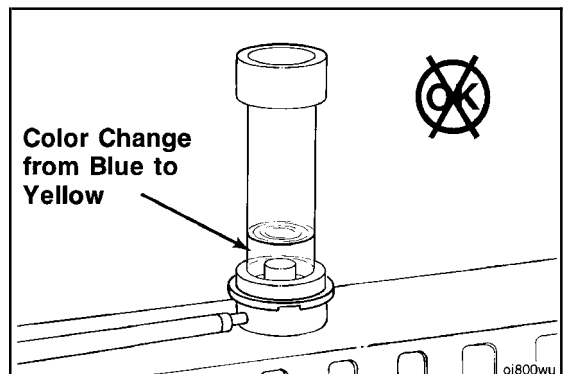

o1800wu

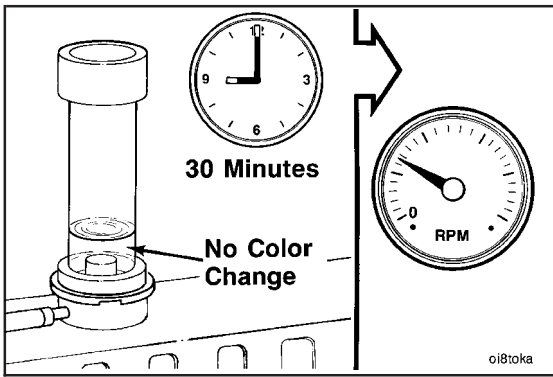

If the color of the test fluid does **not** change from blue to yellow during the 30-minute test period, return the engine to low idle.

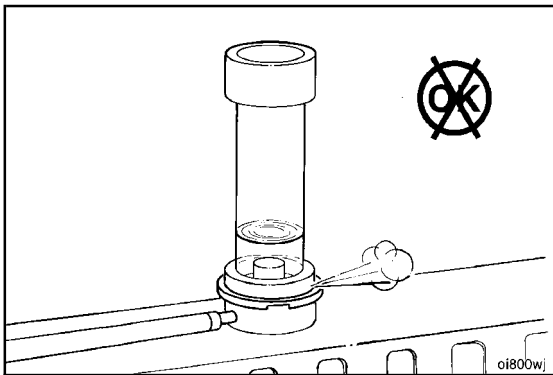

Check the test instrument to make sure that it is firmly sealed in the radiator fill neck.

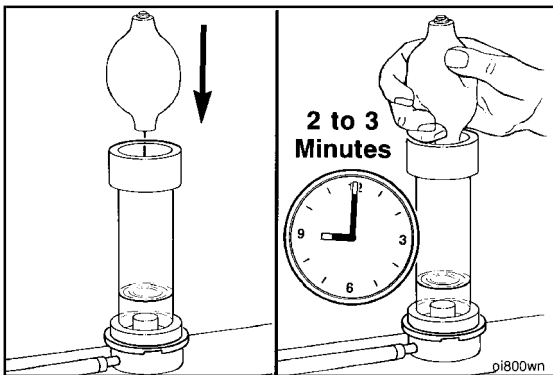

Insert the tip of the rubber ball into the hole in the top of the test instrument. Squeeze the rubber ball 2 to 3 minutes to draw air from the radiator through the test fluid.



If the color of the test fluid remains blue, combustion gases are **not** entering the cooling system. If the color of the test fluid changes from blue to yellow, combustion gases are entering the cooling system. Further investigation is required to determine the source of the combustion leak.

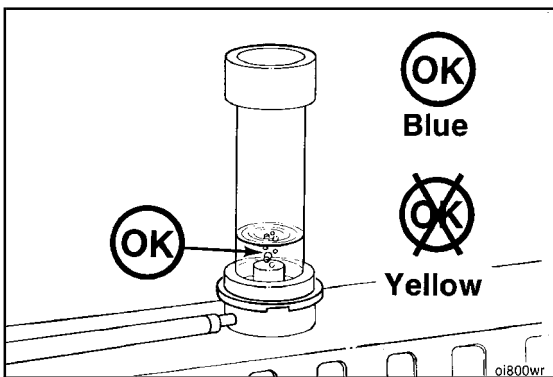

As the cooling system warms up to operating temperature, air will be expelled through the combustion gas tester in the form of bubbles in the test fluid. This is due to normal expansion of the coolant. Do **not** mistake the presence of air bubbles in the tester as combustion gases, or air leaks into the cooling system. A change in the color of the test fluid from blue to yellow is the **only** indication of combustion gas in the cooling system.

A positive result from the combustion gas leak tester indicates the following:

- Cylinder liner protrusion incorrect. Refer to the B Series Shop Manual, Bulletin No. 3666017
- Cylinder head gasket or cylinder head casting leakage. Refer to Procedure 002-004
- Injector sleeve leakage. Refer to Procedure 002-004

**NOTE:** Discard the test fluid if it has indicated positive.

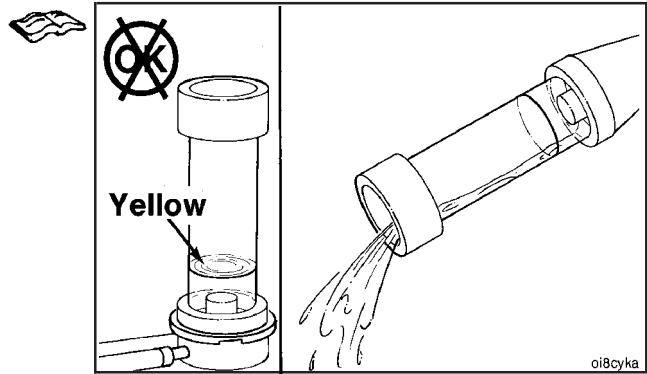

A negative result from the combustion gas leak tester, coupled with continuous flow of air bubbles from the previous test, indicates the following:

- Defective fan, shutter, or heater air control valve
- Air compressor head or head gasket leakage
- Air entrained due to a bad radiator check valve or incorrect fill.

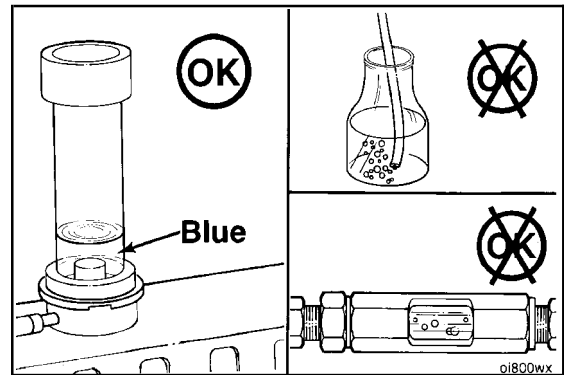

## Cooling System Diagnostics (008-020)

### General Information

When you troubleshoot overheating, remember that too much oil in the oil pan can cause additional heat from friction when the rod journals are submerged in oil.

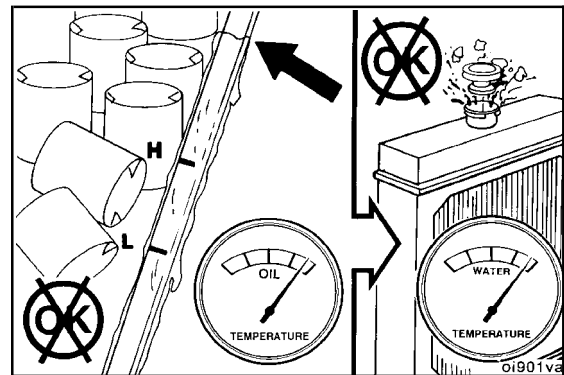

Overfilling with oil raises the oil temperature that is transferred to the coolant system at the oil cooler.

The system is designed to use a specific quantity of coolant. If the coolant level is low, the engine will run hot.

**NOTE:** The engine or system has a leak if frequent addition of coolant is necessary. Find and repair the leak.

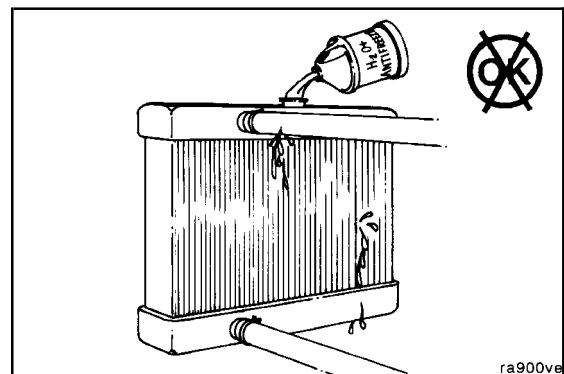

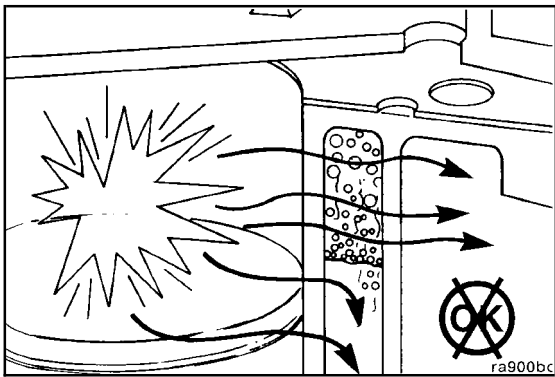

**⚠ CAUTION ⚠**

The engine coolant passages must be completely filled with coolant.

During operation, entrapped air mixes with the coolant, which results in cavitation corrosion and poor heat transfer. Highly aerated coolant can cause localized overheating of the cylinder head and block, which can result in a cracked head, scored cylinder, or blown head gasket.

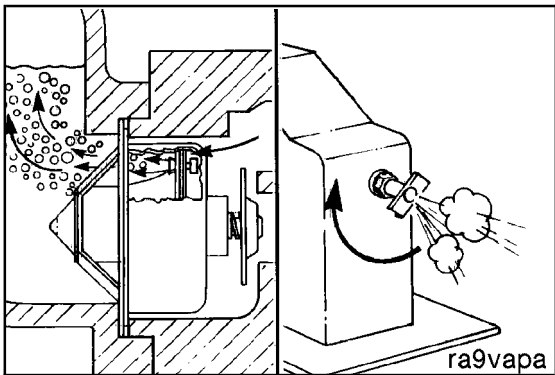

During filling, air **must** be vented from the engine coolant passages. The air vents through the "jiggle pin" openings to the top radiator hose and out the fill opening. Additional venting is provided for engines equipped with an after-cooler. Open the petcock during filling.

**NOTE:** Adequate venting is provided for a fill rate of 14 liters per minute [3.7 gallons per minute].

**NOTE:** Excess air in the cooling system can lead to overheating and low coolant levels.

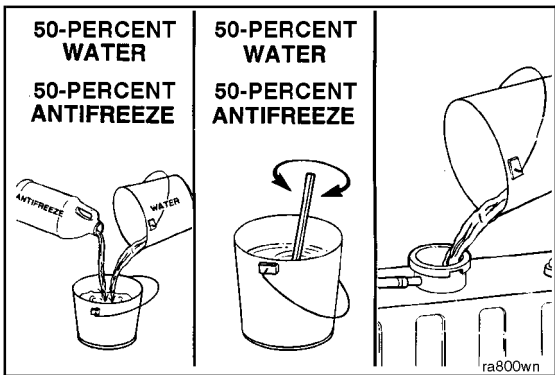

**NOTE:** A 50-percent mixture of antifreeze and water **must** be premixed before filling the system. The ability of antifreeze to remove heat from the engine is **not** as good as water, so pouring antifreeze into the engine first could contribute to an overheated condition before the liquids are completely mixed.

A mixture of 50-percent ethylene-glycol base antifreeze is required for operation of the engine in temperature environments above -37°C [-35°F]. A mixture of 40-percent water and 60-percent antifreeze is recommended for temperatures below -37°C [-35°F]. **Never** use more than 60-percent antifreeze.

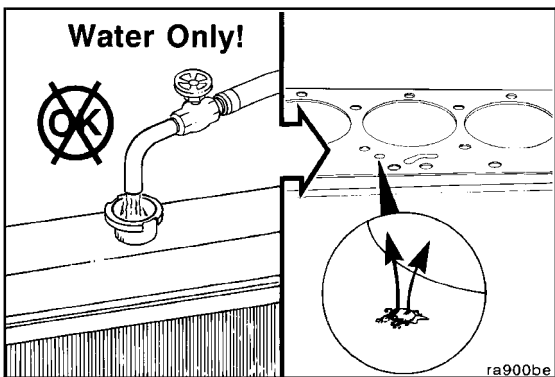

**⚠ CAUTION ⚠**

Never use water alone for coolant. Damage from corrosion can be the result of using water alone for coolant. The small holes in the head gasket are especially susceptible to plugging. These holes are orifices and their size is critical. Do not enlarge the size of the orifices. To do so will disturb the coolant flow and will not solve an overheating problem.

Water will cause rust formation, reducing the flow in the smaller coolant passages.

**B3.9 and B5.9 Series Engines**  
**Section 8 - Cooling System - Group 08**

Also, water used as a coolant for even a relatively short period can result in the cup plugs rusting through, allowing the coolant to leak.

**NOTE:** A sudden loss of coolant from a heavily loaded engine can result in severe damage to the pistons and cylinder bore.

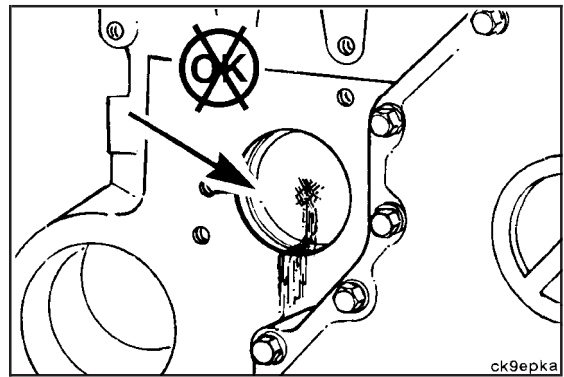

An incorrect or malfunctioning cap can result in the loss of coolant and the engine running hot. Refer to Procedure 008-047.

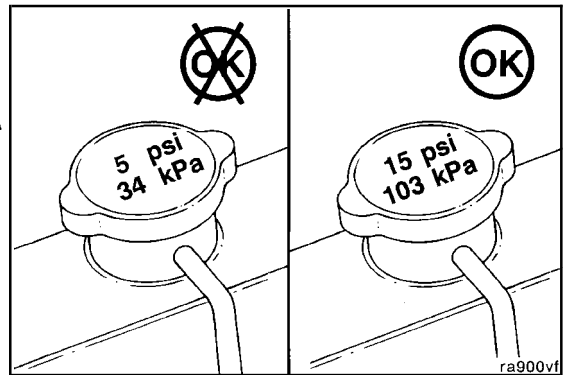

Air in the coolant can result in loss of coolant from the overflow when the aerated coolant is hot. The heated air expands, increasing the pressure in the system, causing the cap to open.

Similarly, coolant can be displaced through the overflow if the head gasket leaks compression gases to the coolant system.

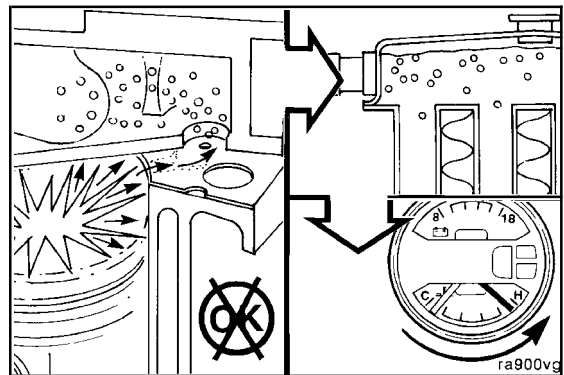

The operating pressure of the coolant system and the lubricating system can result in the mixing of the fluids if there is a leak between the systems: head gasket, oil cooler, etc. (refer to the Lubricating Oil System - Section 7).

**NOTE:** Transmission fluid can also leak into the coolant through radiator bottom tank transmission oil coolers. Refer to the OEM service manual.

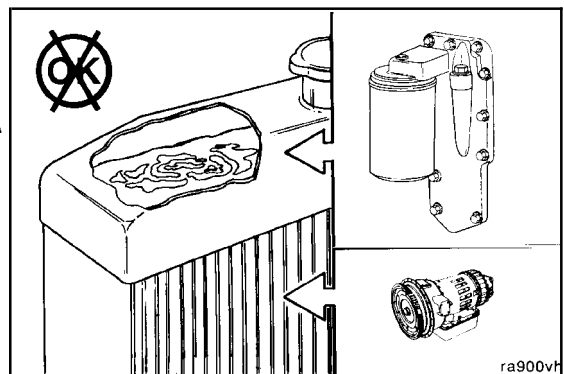

**Water Pump**

The water pump pulls coolant from the bottom of the radiator and pumps it through the engine back to the top of the radiator for cooling. Reduced or interrupted flow will result in the engine running hot.

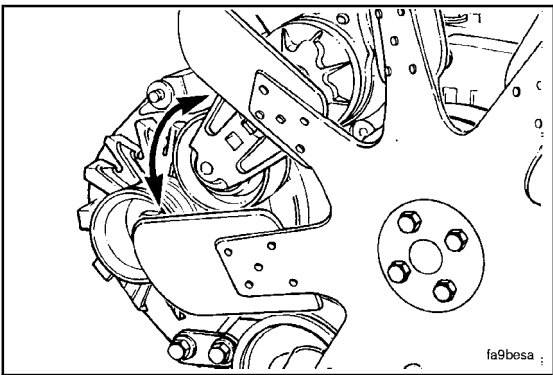
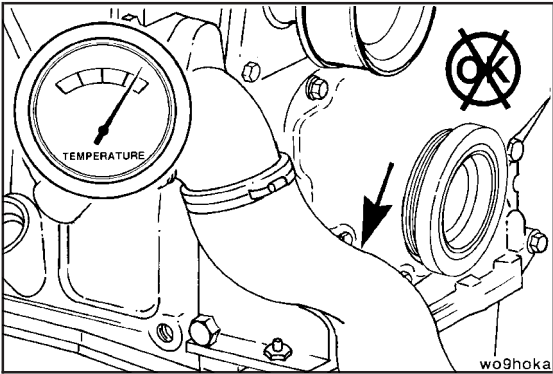

The pump is belt-driven from the crankshaft pulley. An automatic belt tensioner is used to prevent the belt from slipping on the pump pulley. A malfunction of the tensioner will cause the water pump impeller to rotate at a slower speed, reducing the amount of coolant flow.

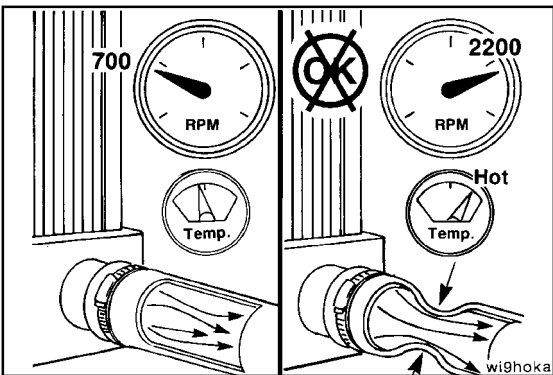

The coolant flow can also be reduced if the inlet hose to the water pump collapses. A hose will usually **not** collapse while the engine is running at low speed. Check the hose while the engine is running at rated speed.

**NOTE:** Be sure the engine is warm, a minimum of 95°C [203°F], so the thermostat is open.

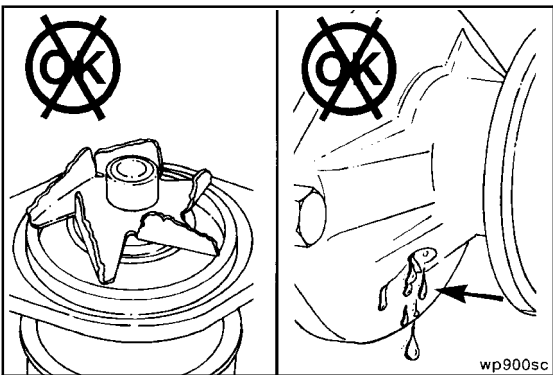

A worn or malfunctioning water pump will **not** produce the flow required to prevent the engine from running hot. However, be sure to check the other possibilities indicated in the Troubleshooting Logic before checking the flow or replacing the pump. Refer to Procedure 008-062.

As stated in the coolant discussion, an obstruction in the passages can interrupt flow.

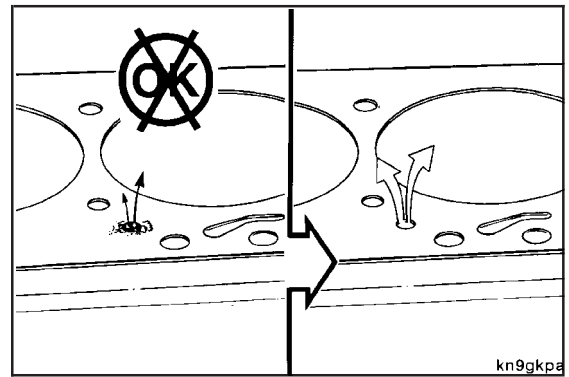

**Radiator, Fans, and Shutters**

Air forced through the fins of the radiator by a fan cools the coolant pumped through the radiator. Environmental debris (paper, straw, lint, dust, etc.) can obstruct the fins and stop the flow of air, which will reduce the cooling effect of the radiator.

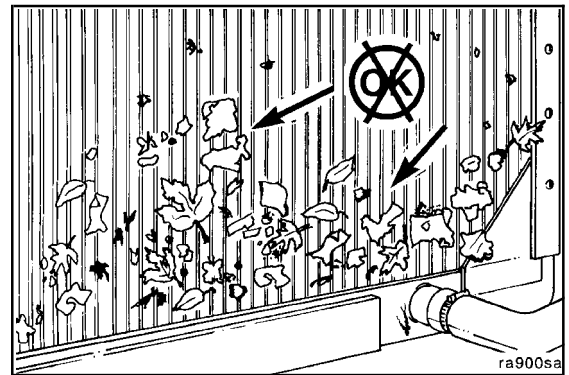

If the fan is belt-driven, a slipping belt will result in slower fan speed and reduced cooling. A malfunctioning automatic belt tensioner can be the problem.

**NOTE:** Check the bearings in the fan hub and other pulleys to make sure they are **not** causing excessive belt vibration and slippage.

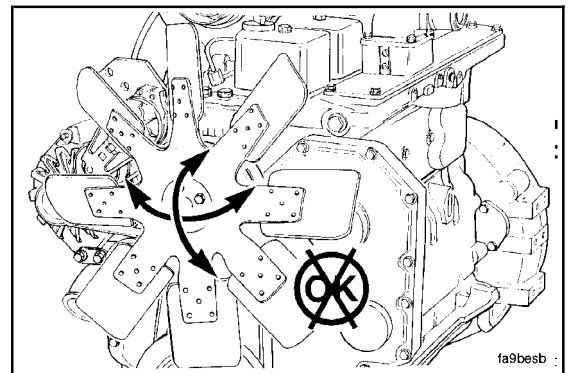

Interruption of the circuit to an electrically driven fan can result in insufficient airflow and cause the engine to run hot.

**NOTE:** Make sure the temperature sensor is functioning correctly.

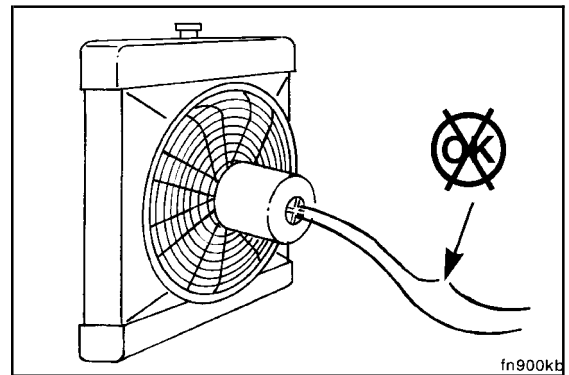

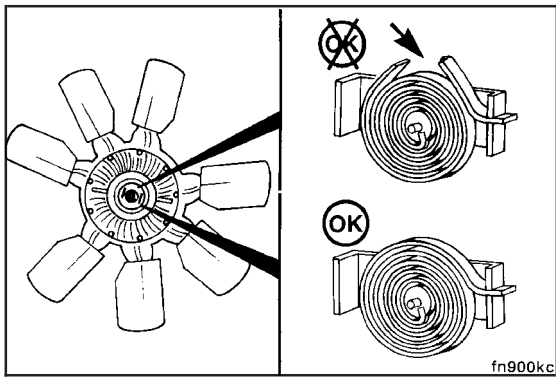

Some applications use thermatic fans. These fans operate **only** as needed to keep the coolant at the correct temperature. If the fan does **not** operate when the coolant temperature increases, the engine will run hot. If the fan does **not** shut off when coolant temperature decreases, the engine will run cold.

**NOTE:** Make sure the coolant temperature sensor is functioning correctly.

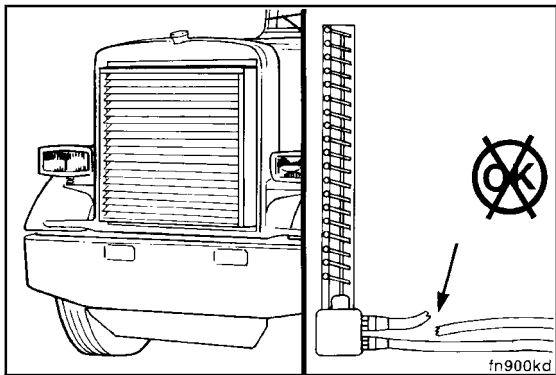

Shutters are designed to control airflow across the radiator. If the shutters fail to open when needed, the engine can run hot. Failure of the shutters to close can result in too much airflow and the engine running cold.

**NOTE:** Make sure that the air temperature sensor is functioning correctly. Check the air-operated shutter controls. Check for air leaks.

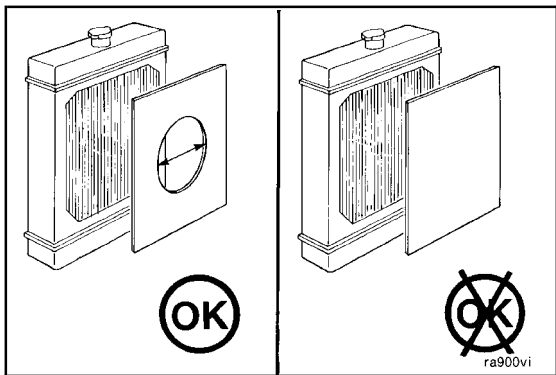

Winterfronts can be used on a charge air cooled engine, but **must** be designed to cover the frontal area of the cooling system partially. A minimum of 120 square inches of charge air cooled frontal area **must** be left open to airflow.

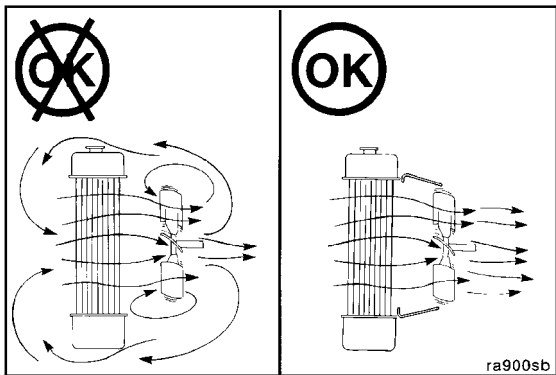

An incorrect fan shroud or obstructions can reduce airflow and cause the engine to run hot.

**NOTE:** Check to be sure air is **not** recirculating. Check for missing baffles.



**Gauges, Overfueling, and Loading**

Gauges and sensors are used in the system to measure the coolant temperature. These can malfunction and provide an incorrect temperature indication.

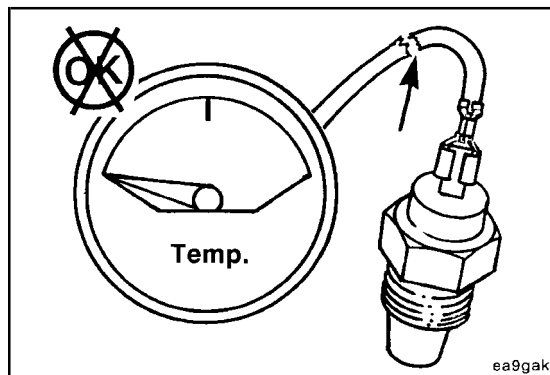

**⚠ CAUTION ⚠**

Overfueling can cause the engine to overheat. Make sure that the fuel pump is calibrated correctly.

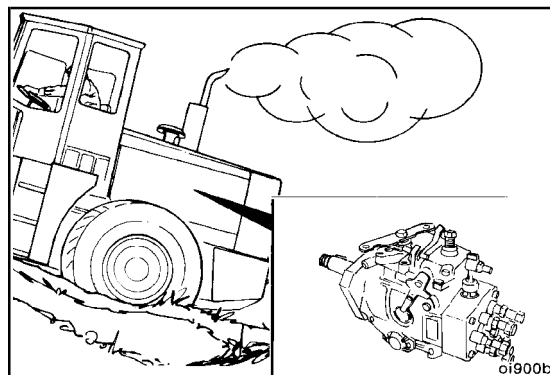

**⚠ CAUTION ⚠**

Constant overloading (lugging) can cause the engine to run hot.

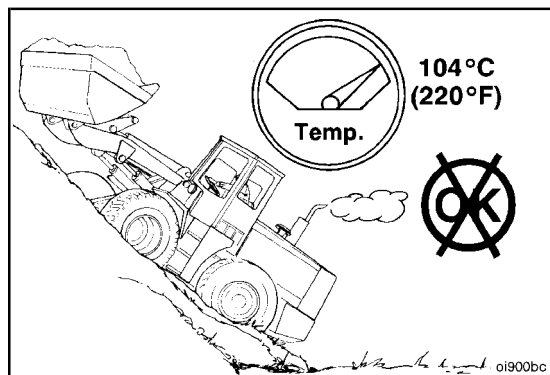

## Fan Clutch, Electric (008-026)

### General Information



**The cooling fan will engage when the engine is started. To avoid personal injury, do not put your hands in the path of a rotating fan.**

The Cummins-developed electromagnetic fan clutch product is an integrated package with the clutch, bracket, shaft, bearings, pulley, and fan spacer designed as a unit. An engine coolant sensor and/or a refrigerant pressure sensor (if equipped with air conditioning) will engage and disengage the clutch. The fan clutch engages when the coolant temperature sensor or the refrigerant switch is closed. It disengages when either of these sensors return to the open position. The most common temperature switch is set to close at 91°C [195°F]. Contact the OEM for recommended temperature switches. The temperature **must** be set above the opening point of the thermostat. When cooling is needed, a powerful electromagnet engages the fan. The fan is either fully engaged or fully disengaged. The OEM could have a manual override switch to engage the clutch manually at the operator's command. The electromagnetic fan clutch is driven by a poly-vee drive belt and is available with an accessory drive for vee-drive belts.

Clutch wires **must** be oriented at 2 o'clock instead of 12 o'clock. The following table lists the component parts of the electric fan clutch.

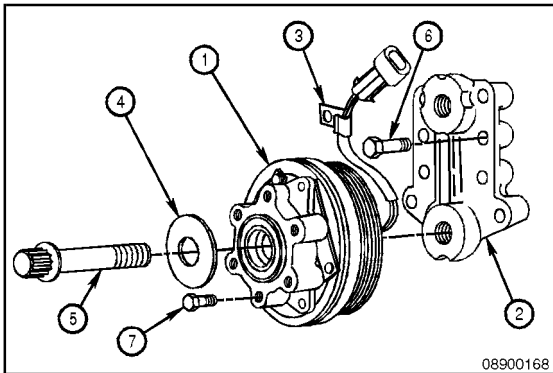
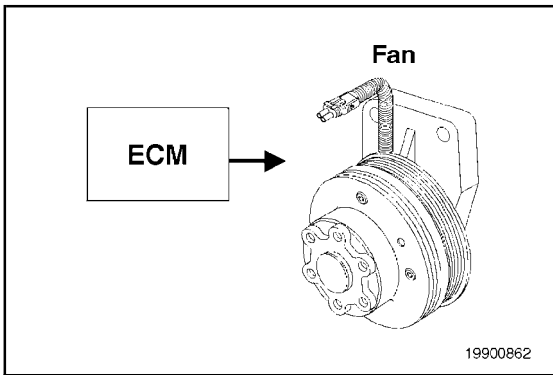

TABLE 1-PARTS BREAKDOWN

The following parts have been released for B Series production and service:

	Part No.	Part Name	Description	Comments
1	3922954	Clutch	B Series with Accessory Drive	1.25:1 Ratio
1	3922773	Clutch	B Series without Accessory Drive	1.25:1 Ratio
2	3922869	Bracket	Fan Center 343 or 393.5 mm [13.5 or 15.5 in]	1 per Assembly
3	3920348	P-Clip		1 per Assembly
4	3922952	Washer		1 per Assembly
5	3922953	Capscrew 12 Point		1 per Assembly
N/A	3862596	Warning Label *		Per Installation
6	3900678	Capscrew		4 per Assembly
7	3903464	Fan Bolts	40-mm [1.6-in] length	6 per Assembly
7	3900634	Fan Bolts	50-mm [1.9-in] length	6 per Assembly
7	3904446	Fan Bolts	70-mm [2.8-in] length	6 per Assembly
7	3900067	Fan Bolts	80-mm [3.15-in] length	6 per Assembly
7	3916069	Fan Bolts	90-mm [3.54-in] length	6 per Assembly

**NOTE:** \* Each 3862496 warning label kit contains two labels. One label **must** be installed on both sides of the fan shroud.

**Remove**

Disconnect the electrical connections, negative (-) cable first, from the batteries.

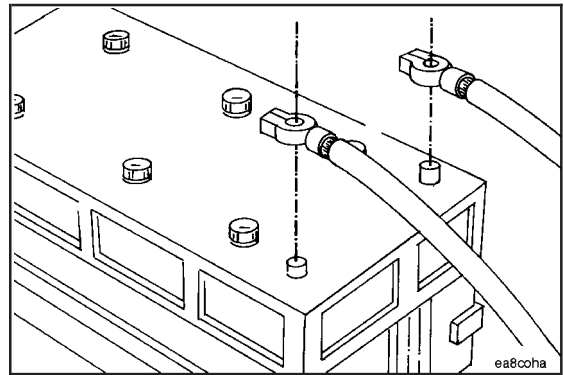

Disconnect the fan clutch connector on the base harness from the fan clutch.

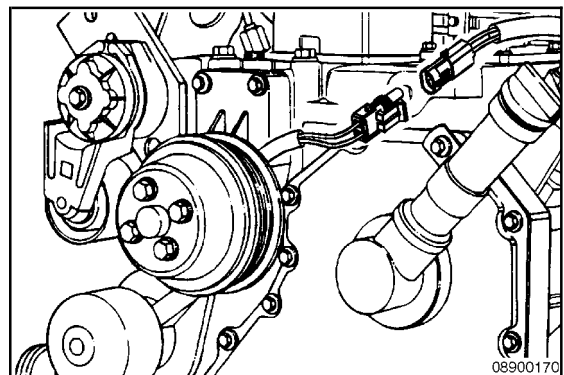

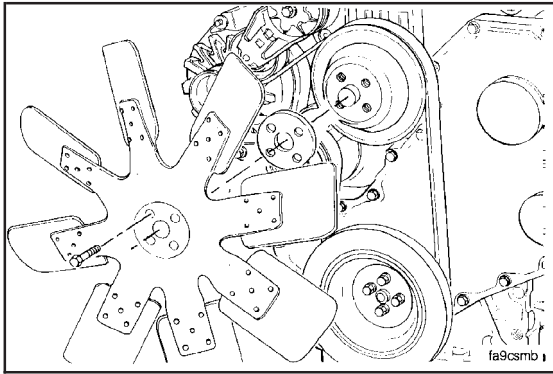

Remove the fan and spacer from the engine.  
Refer to Procedure 008-040.

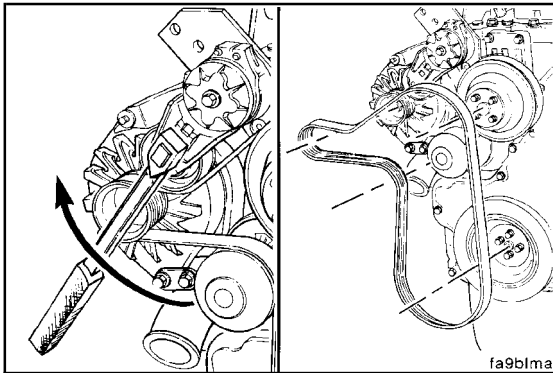

Lift the tensioner, and remove the belt.  
Refer to Procedure 008-002.

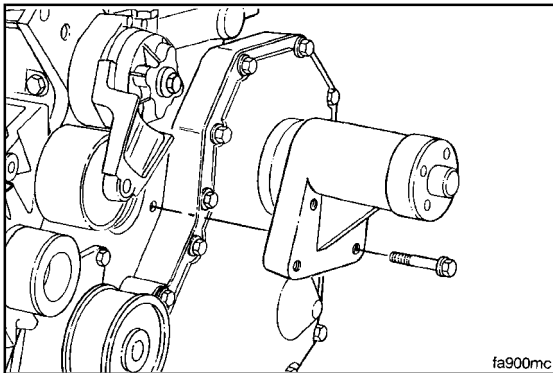

Remove the fan hub, clutch, and capscrews from the engine.  
Refer to Procedure 008-036.

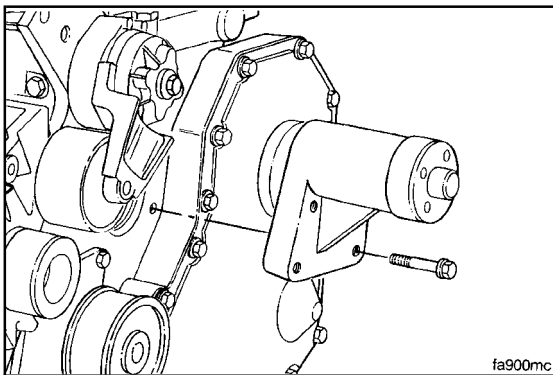

**Install (008-026-026)**

Install the fan hub mounting capscrew, Cummins Part No. 3922953, through the fan clutch; and start threading the capscrew into the fan hub support bracket at the desired fan center location.



Prior to tightening the capscrew, rotate the fan clutch so that the wires coming out of the back of the fan clutch are oriented at the 2-o'clock position (looking at the gear cover).

Tighten the fan clutch mounting capscrew.

**Torque Value:** 203 N•m [150 ft-lb]

Lift the tensioner, and install the belt.  
 Refer to Procedure 008-002.

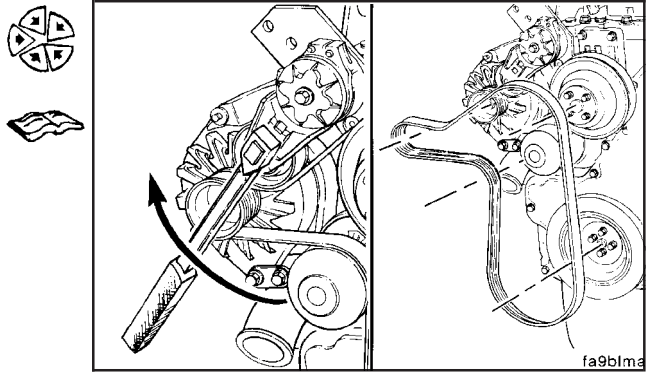

Install the fan, spacers, and capscrews. Tighten the capscrews to the fan manufacturer's specifications.  
 Refer to Procedure 008-040.

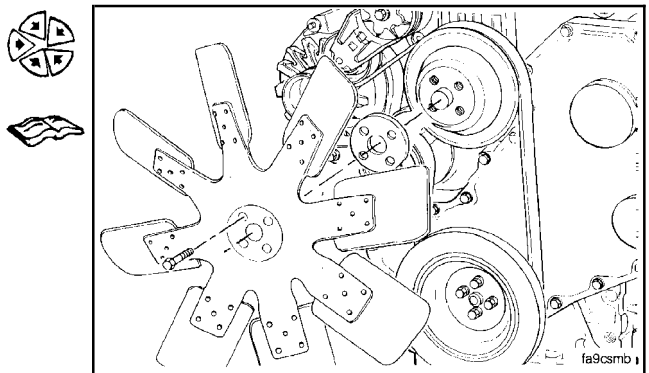

Remove the top right-hand fan hub support bracket mounting capscrew.

Install the p-clip, Cummins Part No. 3920348, to support the fan clutch wires.

Tighten the fan hub mounting capscrew.

**Torque Value:** 45 N•m [33 ft-lb]

Insert the wires into the p-clip, Cummins Part No. 3920348. Make sure that wires are **not** being pulled at fan clutch.

Bend p-clip until hand-tight.

Connect the fan clutch connector on the base harness to the fan clutch.

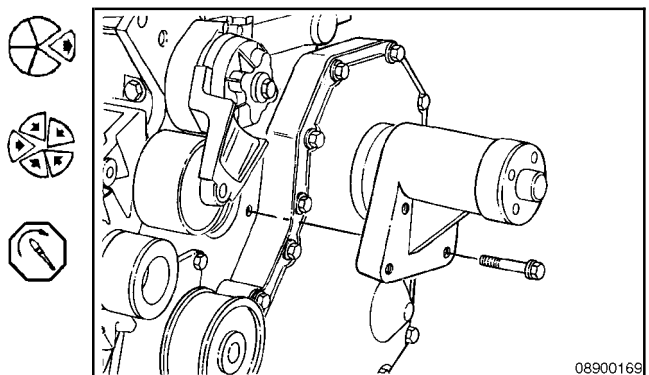

**Fan Hub, Belt Driven (008-036)**

**Preparatory (008-036-000)**

- Remove the drive belt. Refer to Procedure 008-002.
- Remove the fan pulley. Refer to Procedure 008-039.

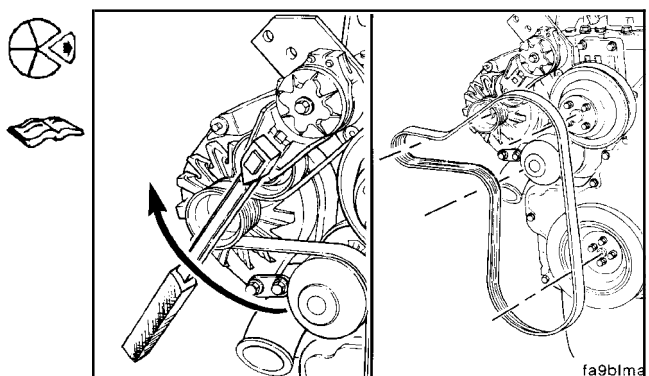

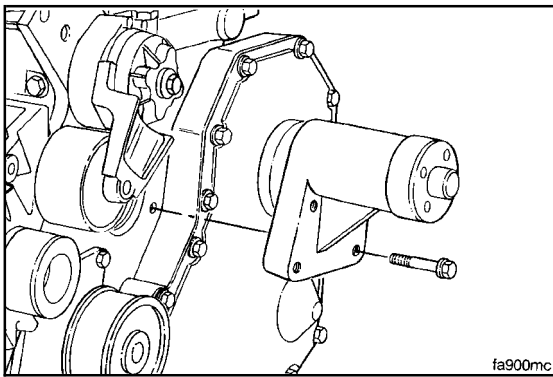

**Remove (008-036-002)**

10 mm



Remove the four capscrews and fan hub.

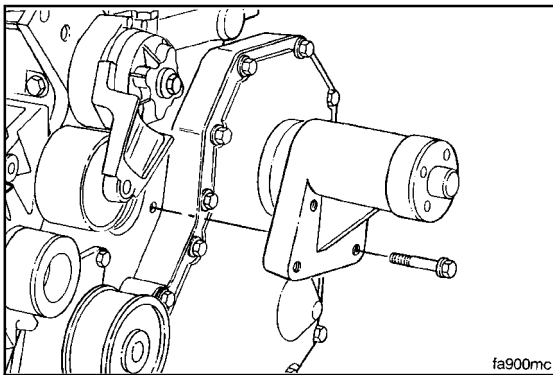

**Install (008-036-026)**

10 mm



Install the fan hub and four capscrews.

**Torque Value:** 24 N•m [18 ft-lb]

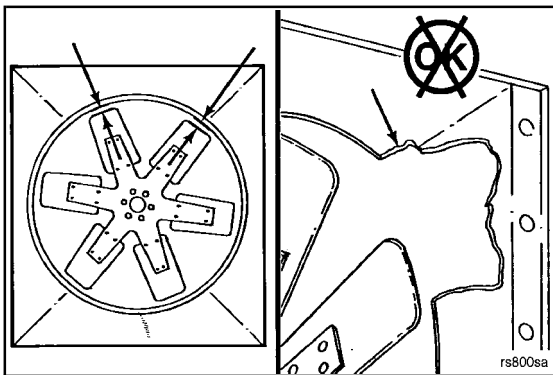

**Fan Shroud Assembly (008-038)**

**Initial Check (008-038-001)**



**▲ CAUTION ▲**

The fan shroud must be installed correctly, be in good condition, and the shroud-to-fan clearance must be within the manufacturer's specifications for proper airflow through the radiator to provide adequate engine cooling.

Inspect the fan shroud for proper fan clearance, cracks, air leaks, or damage. Replace, if necessary. Refer to the equipment manufacturer's service manual for instructions.

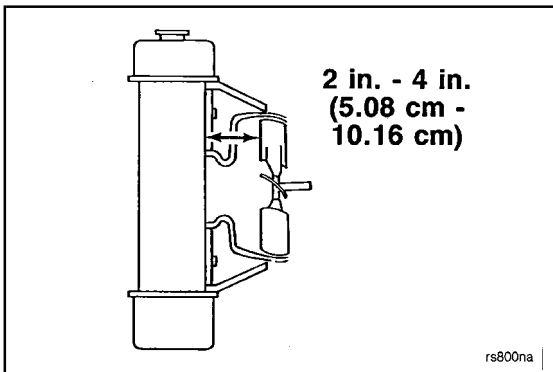

Cummins recommends fan clearance be 5.08 to 10.16 cm [2 to 4 in] from the radiator core. Refer to the equipment manufacturer's service manual for alternative positions.



## Fan Spacer and Pulley (008-039)

### Preparatory (008-039-000)



**Coolant is toxic. If not reused, dispose of in accordance with local environmental regulations.**

- Drain the coolant. Refer to Procedure 008-018.
- Remove the drive belt. Refer to Procedure 008-002.

**NOTE:** Loosen the capscrews before removing the belt, and tighten the capscrews after the belt is installed.

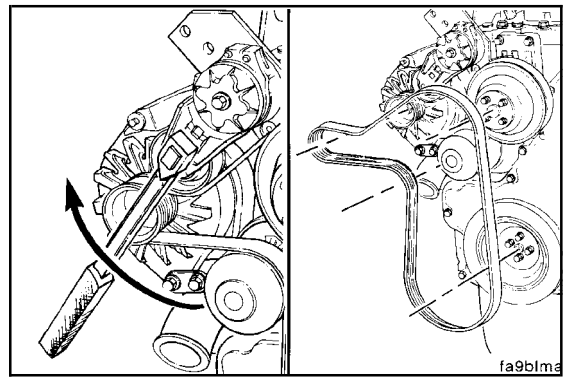

### Remove (008-039-002)

13 mm

Remove the four capscrews, fan, and spacer.

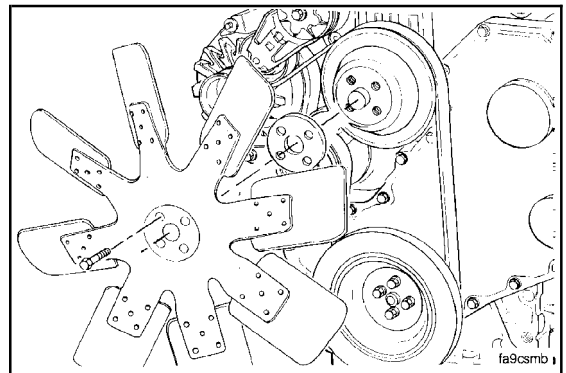

### Install (008-039-026)

3/8-Inch Square Drive

Lift the tensioner, and install the belt.

**Service Tip:** If difficulty is experienced installing the drive belt (the belt seems too short), position the belt over the grooved pulleys first; then, while holding the tensioner up, slide the belt over the water pump pulley.

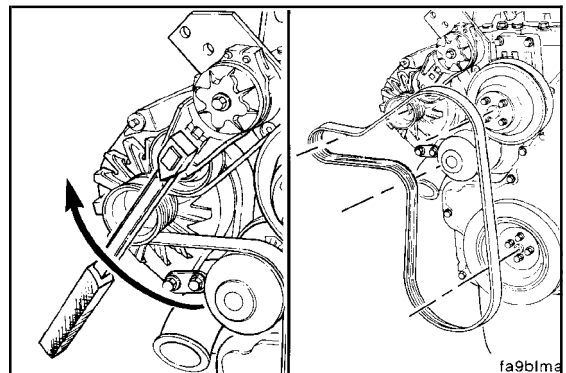

10-mm, 13 mm

Install the four capscrews, fan, and spacer.

10-mm Wrench

Torque Value: 24 N•m [18 ft-lb]

13- mm Wrench

Torque Value: 43 N•m [32 ft-lb]



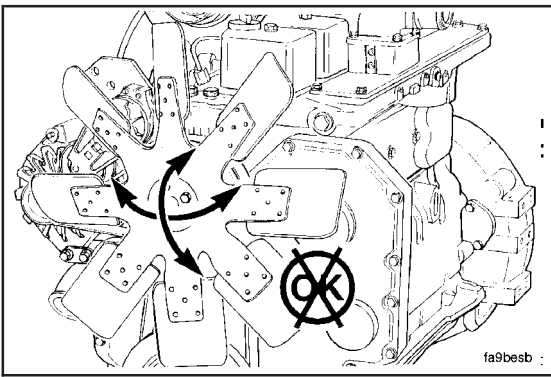

## Fan, Cooling (008-040)

### General Information

If the fan is belt-driven, a slipping belt will result in a slower fan speed and reduced cooling. A malfunctioning automatic belt tensioner can be the problem.

**NOTE:** Check the bearings in the fan hub and other pulleys to make sure they are **not** causing excessive belt vibration and slippage.

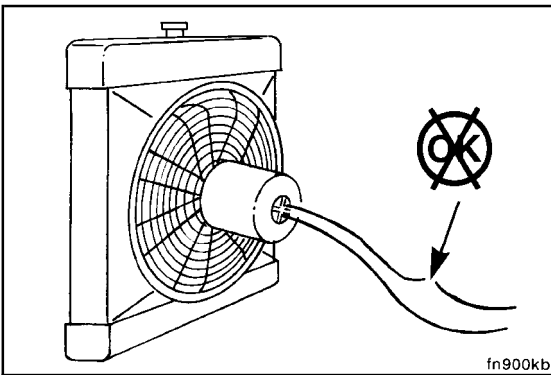

Interruption of the circuit to an electrically driven fan can result in insufficient airflow and can cause the engine to run hot.

**NOTE:** Make sure that the temperature sensor is functioning correctly.

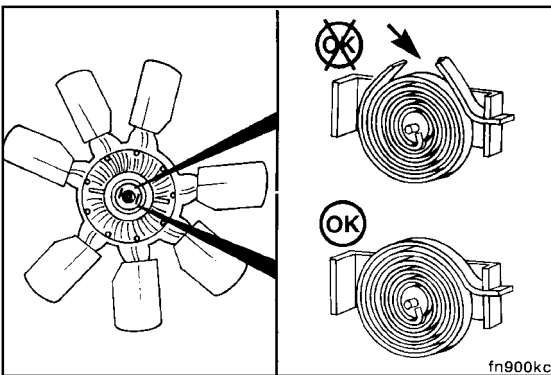

Some applications use thermatic fans. These fans operate **only** as needed to keep the coolant at the correct temperature. If the fan does **not** operate when the coolant temperature increases, the engine will run hot. If the fan does **not** shut off when coolant temperature decreases, the engine will run cold.

**NOTE:** Make sure the temperature sensor is functioning correctly.

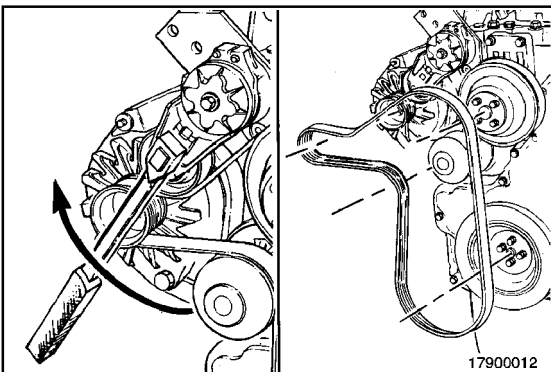

### Remove (008-040-002)

#### 3/8-Inch Square Drive

Lift the tensioner to relieve tension in the belt.

Remove the belt. Refer to Procedure 008-002.



**NOTE:** The belt tensioner is spring-loaded and **must** be pivoted away from the drive belt. Pivoting in the wrong direction can result in damage to the belt tensioner.





**Inspect for Reuse (008-040-007)**

**▲ WARNING ▲**

Do not straighten a bent fan blade or continue to use a damaged fan. A bent or damaged fan blade can fail during operation and cause personal injury or property damage.

Inspection of the cooling fan is required daily. Check for cracks, loose rivets, and bent or loose blades. Check the fan to make sure it is securely mounted. Tighten the capscrews, if necessary.

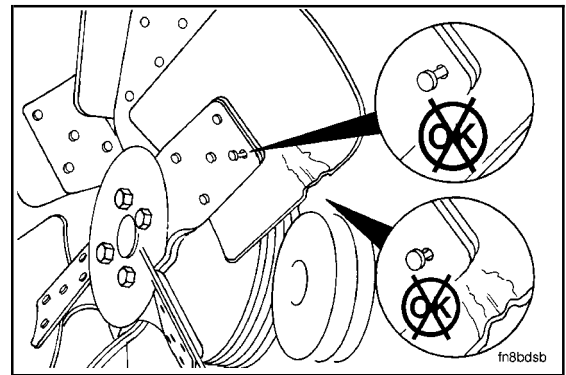

**▲ WARNING ▲**

Do not straighten a bent fan blade or continue to use a damaged fan. A bent or damaged fan blade can fail during operation and cause personal injury or property damage.

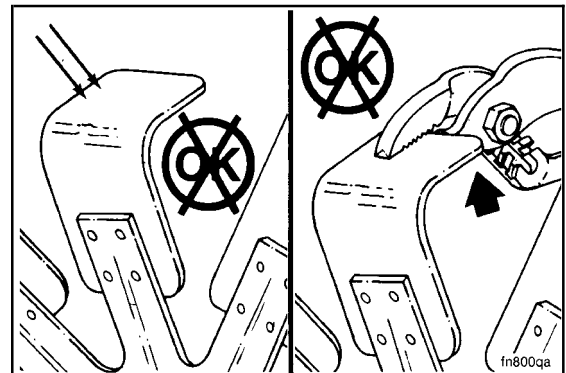

Replace original equipment fan that is damaged with a fan of the identical part number. Cummins Engine Company **must** approve any other fan changes to be covered under warranty.

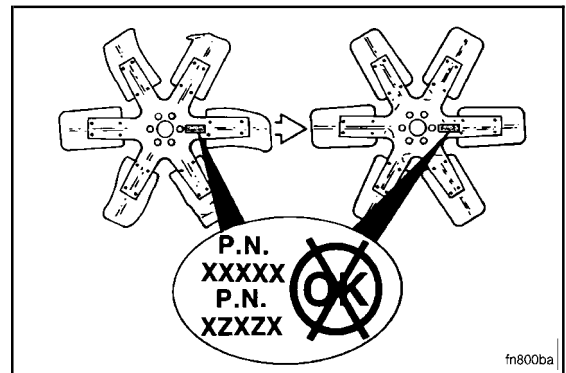

**Install (008-040-026)**

8 mm, 10 mm

Install the spacer, fan, and fan capscrews.

8 mm

**Torque Value:** 24 N•m [18 ft-lb]

10 mm

**Torque Value:** 43 N•m [32 ft-lb]

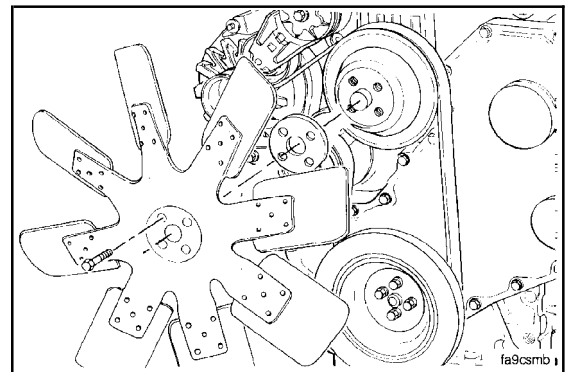

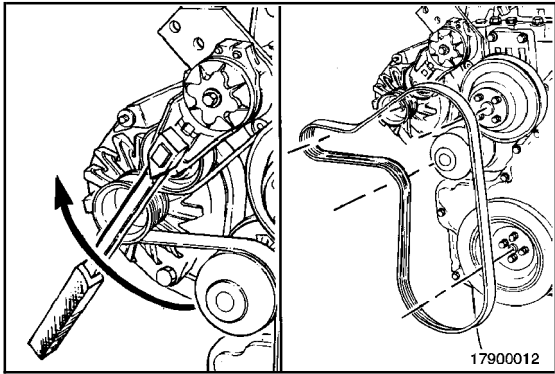

**3/8-Inch Square Drive**

Lift and hold the belt tensioner.



Install the drive belt, and release the tensioner. Refer to Procedure 008-002.

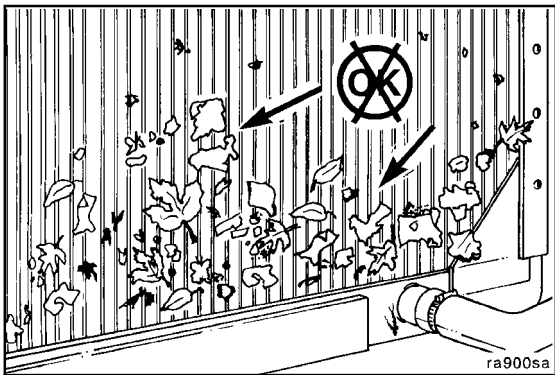

**Radiator (008-042)**

**General Information**

Air forced through the fins of the radiator by a fan cools the coolant pumped through the radiator. Environmental debris (such as paper, straw, lint, and dust) can obstruct the fins and stop the flow of air, which will reduce the cooling effect of the radiator.

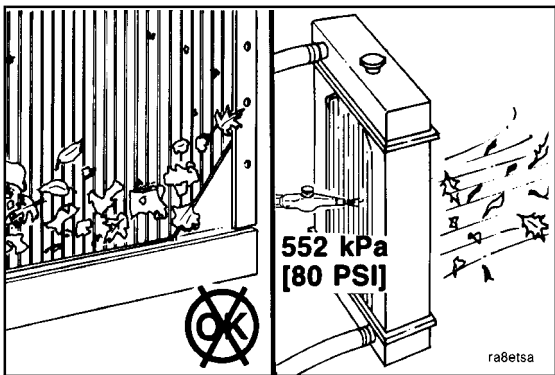

**Initial Check (008-042-001)**



**Wear appropriate eye and face protection when using compressed air. Flying debris and dirt can cause bodily injury.**



Inspect for plugged radiator fins.

Use compressed air to blow out the dirt and debris.

**Air Pressure:** 552 kPa [80 psi]

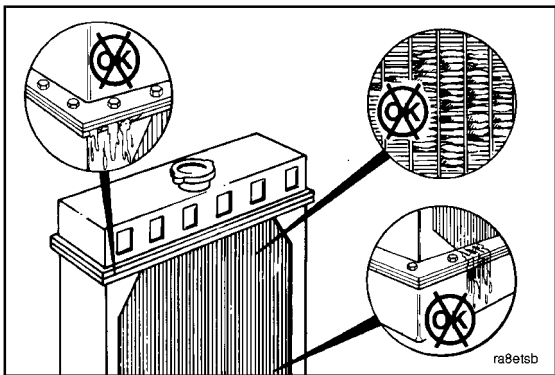

Inspect for bent or broken fins.

Inspect for radiator core and gasket leaks.



If the radiator **must** be replaced, refer to the equipment manufacturer's replacement procedures.

**▲ WARNING ▲**

If a liquid refrigerant system must be removed before removing the radiator, wear eye and face protection. Wrap cloth around the fittings before removal. Liquid refrigerant can cause serious eye and skin injury.

For environmental protection, federal regulations require that freon be recycled and **not** vented into the atmosphere.

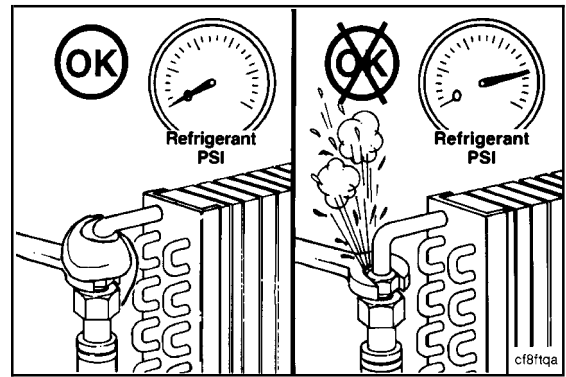

**Radiator Hoses (008-045)**

**Inspect for Reuse (008-045-007)**

Inspect all hoses for cracks, cuts, or collapsing.

**NOTE:** The silicone engine coolant hose will exhibit swelling due to the elasticity of the hose.

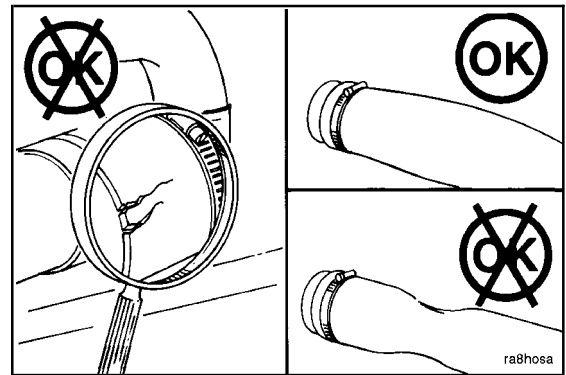

**Radiator Pressure Cap (008-047)**

**General Information**

**Pressure Caps**

The system is designed to use a pressure cap to prevent boiling of the coolant.

Different caps are specified for the two recommended systems:

Radiator Cap Pressure Test		
System		Cap
A (Normal-Duty)	104°C [219°F]	103 KPa [15 psi]
B (Light-Duty)	99°C [210°F]	48 KPa [7 psi]

**NOTE:** An incorrect or malfunctioning cap can result in the loss of coolant and the engine running hot.

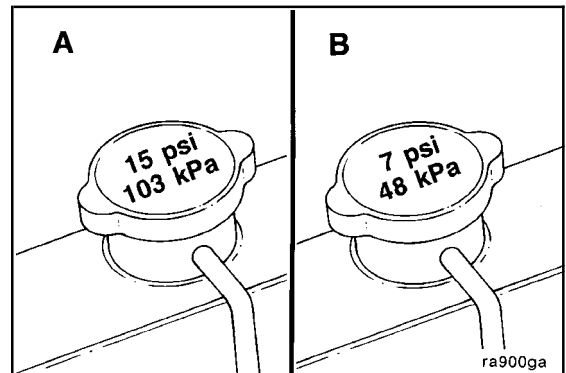

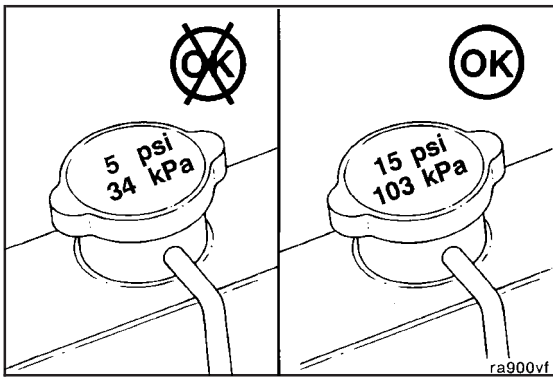

An incorrect or malfunctioning cap can result in loss of coolant and the engine running hot.

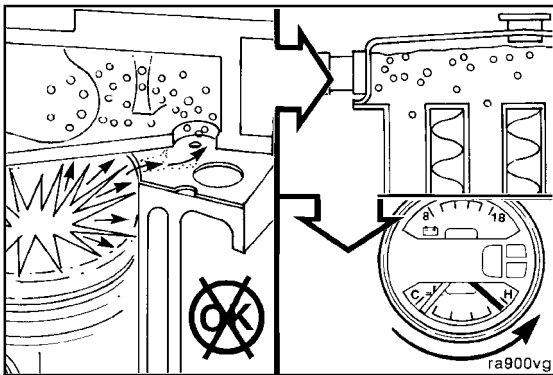

Air in the coolant can result in loss of coolant from the overflow when the aerated coolant is hot. The heated air expands, increasing the pressure in the system, causing the cap to open.

Similarly, coolant can be displaced through the overflow if the head gasket leaks compression gases to the coolant system.

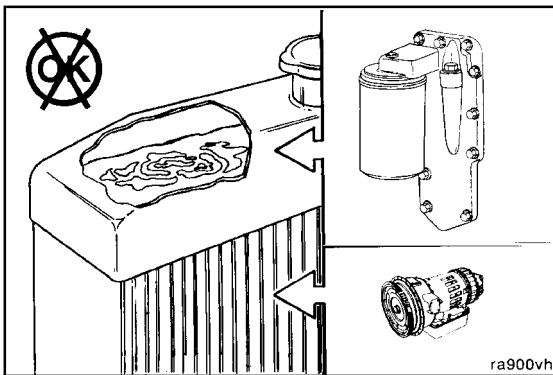

The operating pressure of the coolant system and the lubricating system can result in the mixing of the fluids if there is a leak between the systems, such as the head gasket or oil cooler (refer to Section 7, Lubricating Oil System).



**NOTE:** Transmission fluid can also leak into the coolant through radiator bottom tank transmission oil coolers. Refer to the OEM service manual.

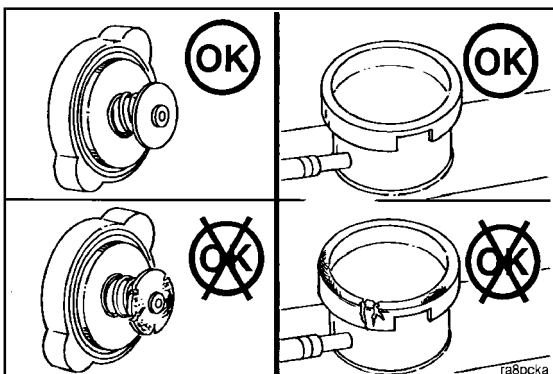

**Inspect for Reuse (008-047-007)**

Be sure the correct radiator cap is being used. Refer to Cooling System - Specifications.



Inspect the rubber seal of the pressure cap for damage.

Inspect the radiator fill neck for cracks or other damage.

Refer to the radiator manufacturer for instructions if the fill neck is damaged.

**Pressure Test (008-047-013)**

The system is designed to use the pressure cap to prevent boiling of the coolant.

Different caps are specified for the two recommended systems:

System	Cap
A-Normal-Duty 104°C [219°F]	103 kPa [15 psi]
B-Light-Duty 99°C [210°F]	48 kPa [7 psi]

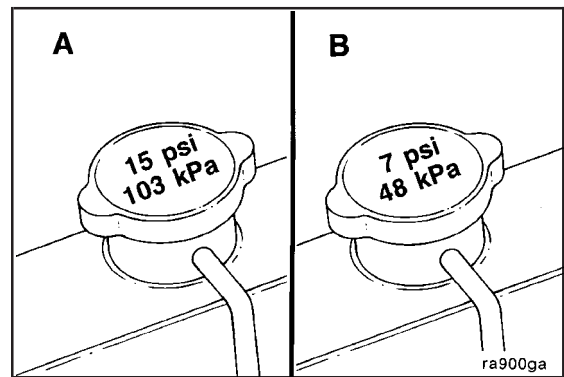

Pressure-test the radiator cap.

The pressure cap **must** seal within the value stated on the cap, or it **must** be replaced.

**NOTE:** An incorrect or malfunctioning cap can result in loss of coolant and the engine running hot.

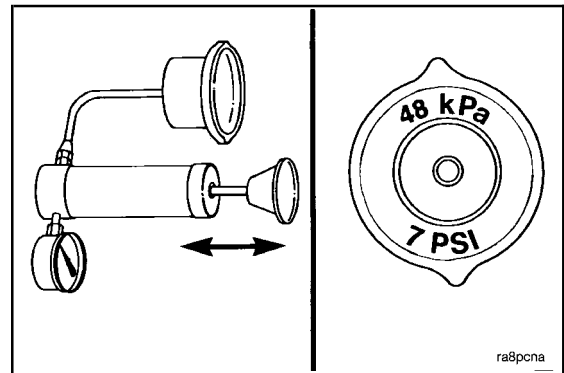

**Radiator Shutter Assembly (008-049)**

**General Information**

Shutters are designed to control airflow across the radiator. If the shutters fail to open when needed, the engine can run hot. Failure of the shutters to close can result in too much airflow and the engine running cold.

**NOTE:** Make sure the air temperature sensor is functioning correctly. Check the air-operated shutter controls. Check for air leaks. Refer to the equipment manufacturer's service manual.

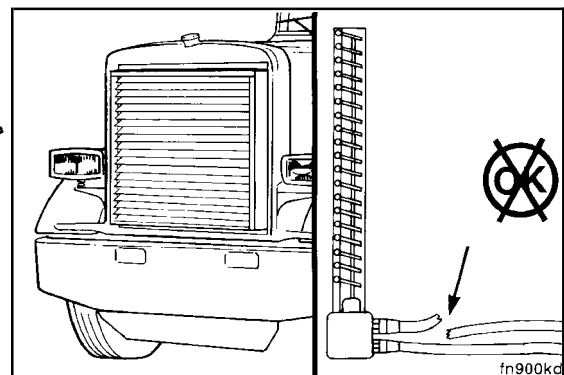

Winterfronts can be used on a charge air cooled engine, but **must** be designed to cover the frontal area of the cooling system partially. A minimum of charge air cooled frontal area **must** be left open to air flow.

**Winterfronts:** 302<sup>2</sup> mm [60<sup>2</sup> in]

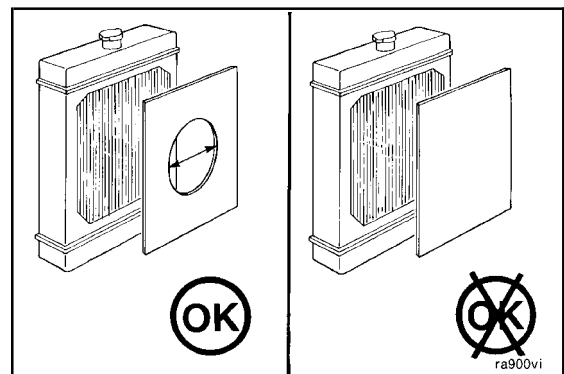

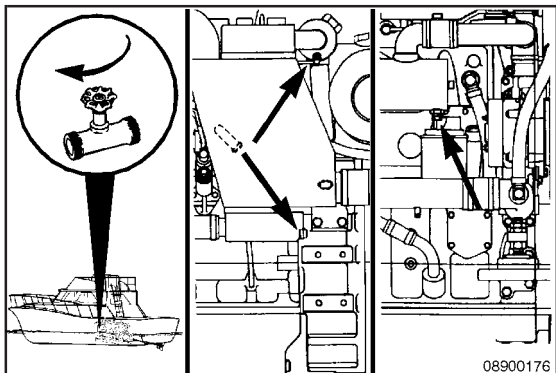

**Sea Water Heat Exchanger (008-053)  
Flush (008-053-009)**



7/16 Inch

Shut off the sea water valve on the vessel hull.

Remove the marine gear oil cooler drain plug and the zinc plugs from the aftercooler, if so equipped.

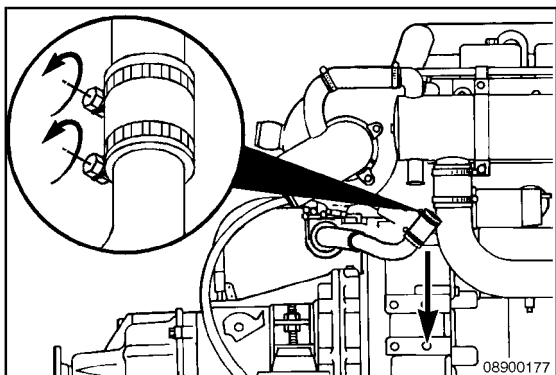

5/1-Inch Nutdriver or Screwdriver

Disconnect the raw water inlet connection.

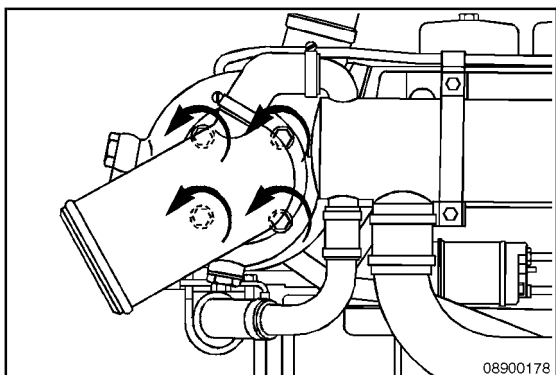

10 mm, 5/16-Inch Nutdriver or Screwdriver

Remove the turbocharger exhaust elbow.

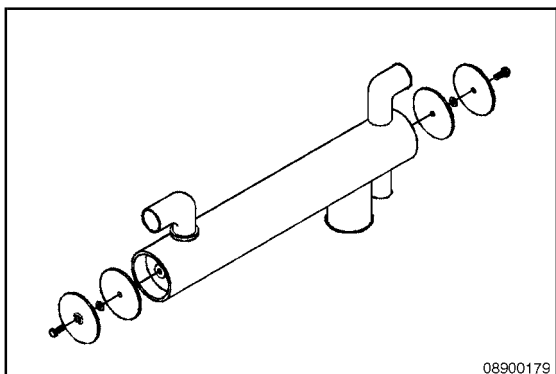

9/16 Inch

Remove the heat exchanger end caps.



**B3.9 and B5.9 Series Engines  
Section 8 - Cooling System - Group 08**

Use a 4.76-mm [3/16-in] diameter brass rod to clean out any buildup in the heat exchanger tubes.

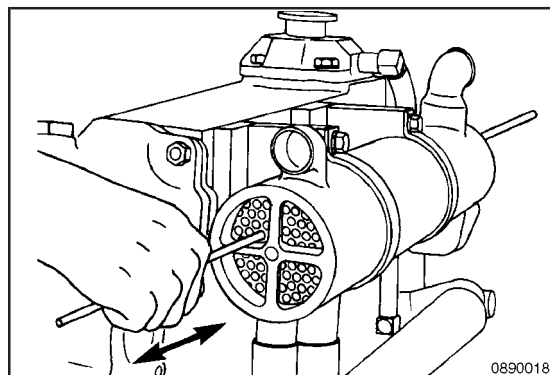

08900180

Use clean water to flush the heat exchanger tubes from the rear. Make sure the end cavities are cleared of all debris.

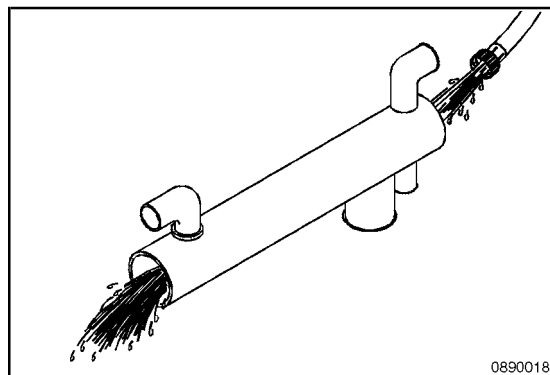

08900181

**9/16 Inch**

Use new sealing washers (2) and gaskets (4) when installing the end caps (3).

Tighten the retaining screws (1).

**Torque Value:** 2.7 N•m [24 in-lb]

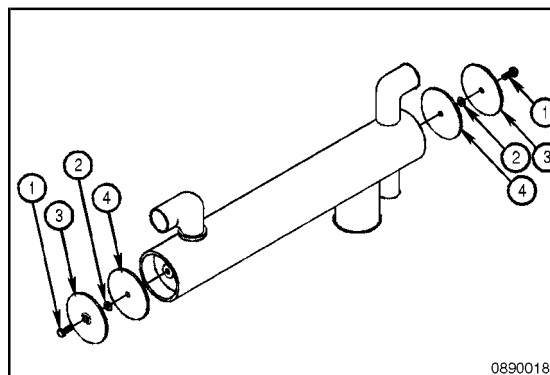

08900182

**11/16 and 7/8 Inch**

Install the zinc plug.

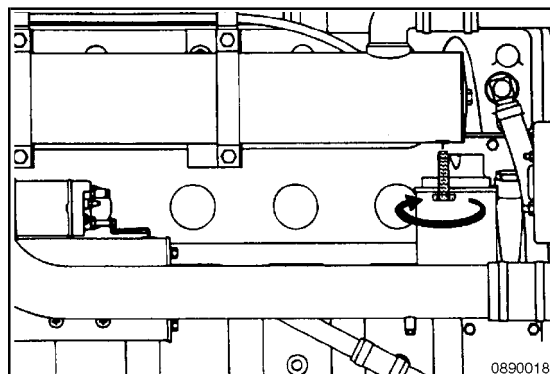

08900183

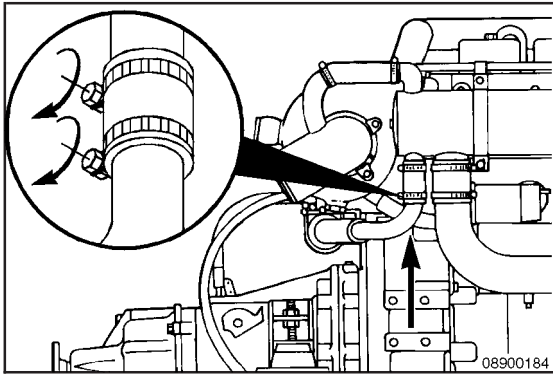

**5/16-Inch Nutdriver or Screwdriver**  
Install the raw water inlet connection.



**Torque Value:** 5 N•m [44 in-lb]

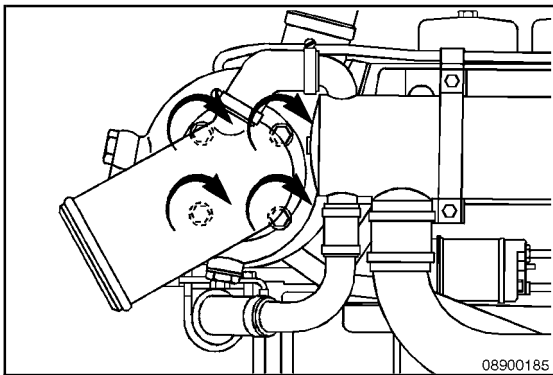

**10-mm, 5/16-Inch Nutdriver or Screwdriver**  
Install the turbocharger exhaust connection.



Tighten the mounting screws.

**Torque Value:** 24 N•m [18 ft-lb]

Tighten the elbow hose clamp.



**Torque Value:** 5 N•m [44 in-lb]

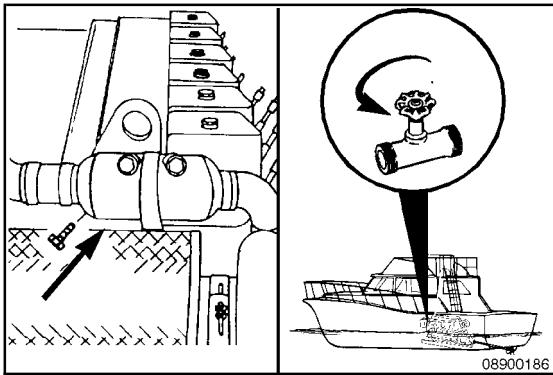

**7/16 Inch**

Install the marine gear oil cooler drain plug.



Open the raw water valve on the vessel hull.

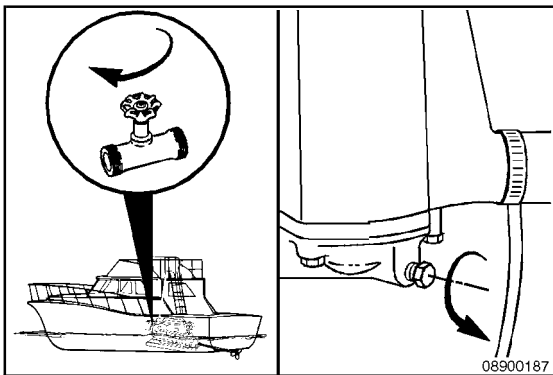

**Raw Water Aftercooler - Cleaning/Flushing**

**7/8 Inch**

Shut off the raw water supply valve on the vessel hull.



Remove the zinc plug from the aftercooler lower water header to drain the aftercooler.



**5/16-Inch Nutdriver**

Remove the raw water transfer tubes from the aftercooler.

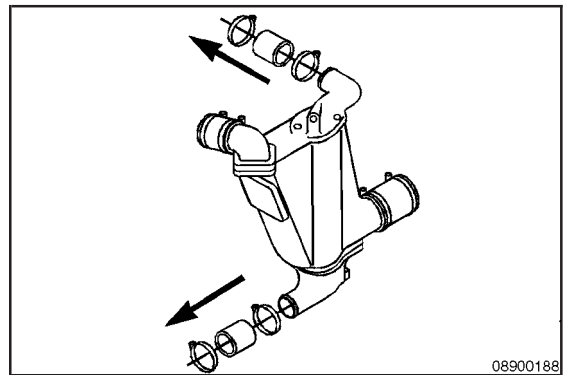

08900188

**7/16 Inch**

Loosen the T-bolt clamps on the aftercooler air inlet and air outlet hose couplings. Remove the hose couplings from the aftercooler. Engines equipped with the air heater will require removal of the heater element wiring; some engines have the throttle cable attached to the aftercooler that will require removal.

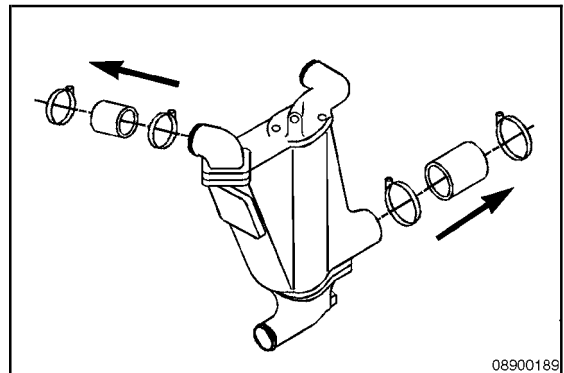

08900189

**13 mm**

Remove the two hex-head flange capscrews that hold the cast aftercooler to the flywheel housing bracket and the two that hold the aftercooler to the intake manifold bracket.

Remove the aftercooler.

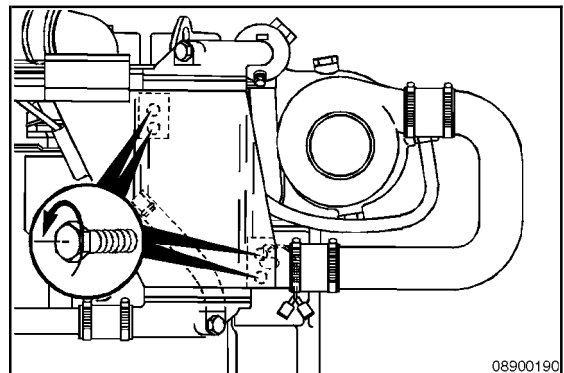

08900190

To cool the intake air properly, the core **must** be positioned with the flat sides to the front and rear. When the core is correctly positioned, the tube rows will be at 90 degrees to the engine centerline as shown in the illustration. Be sure the o-rings on each end of the core are in position to fit into the housing chamfers when the core is installed.

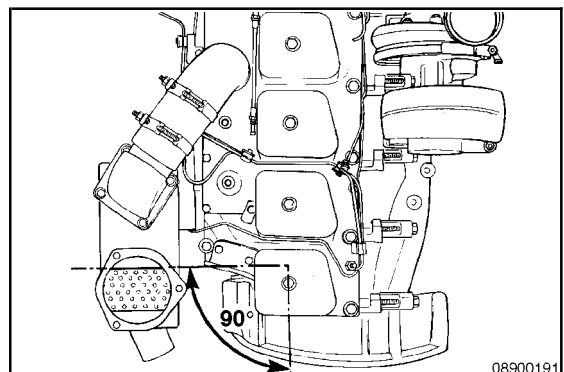

08900191

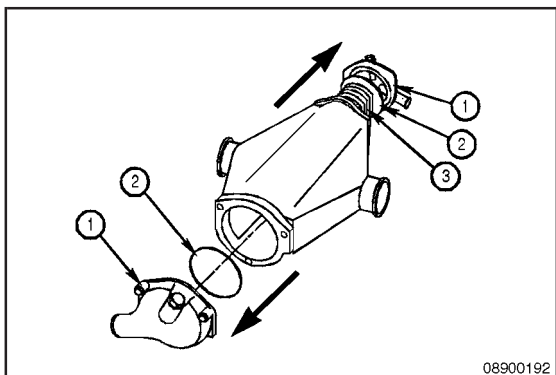

17 mm

Remove the top and bottom end caps (1) from the housing and the o-rings (2) from the core (3).

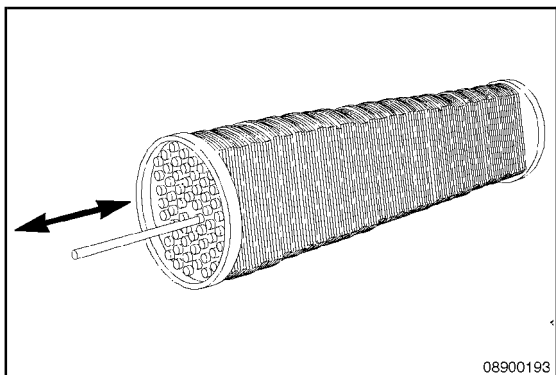

Use a 4.76-mm [3/16-in] diameter brass rod to clean out any buildup of scale in the aftercooler tubes.

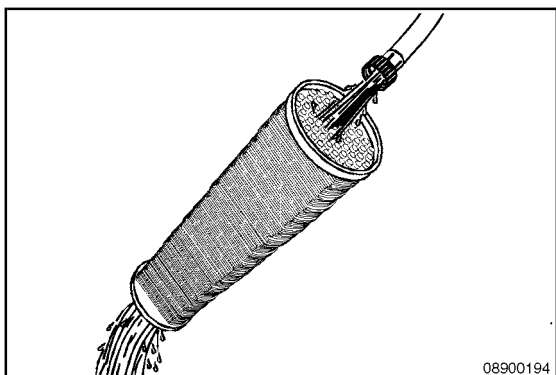

Use clean water to flush the tubes of any loose debris.

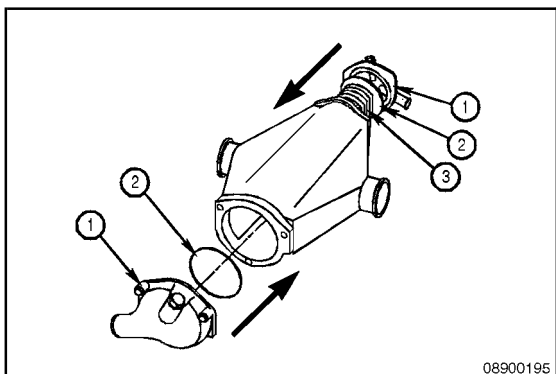

17 mm

Install the core (3) into the housing. Install the o-rings (2) onto the ends of the core and then install the top and bottom end caps (1).



**Torque Value:** 30 N•m [22 ft-lb]



**13 mm**

Install the two capscrews that hold the cast aftercooler to the intake manifold bracket.

Install the two capscrews that hold the cast aftercooler to the flywheel housing bracket.

**Torque Value:** 30 N•m [22 ft-lb]

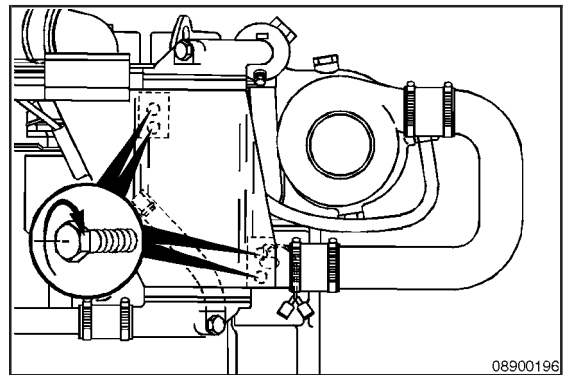

**7/16 Inch**

Install the air inlet and air outlet hose couplings on the aftercooler. Tighten the T-bolt clamps.

**Torque Value:**

T-Bolt Type	8 N•m	[71 in-lb]
Worm Type	5 N•m	[44 in-lb]

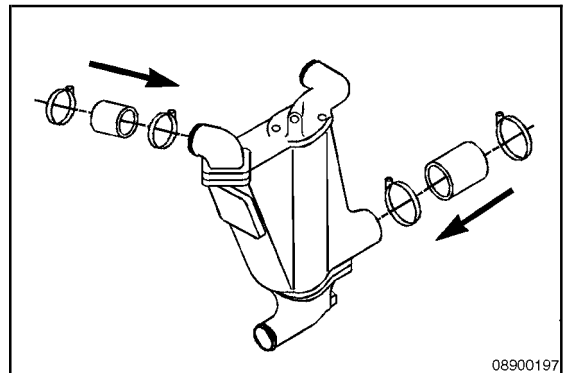

**5/16-Inch Wrench or Flat Screwdriver**

Install the raw water transfer tube couplings on the aftercooler.

**Torque Value:** 5 N•m [44 in-lb]

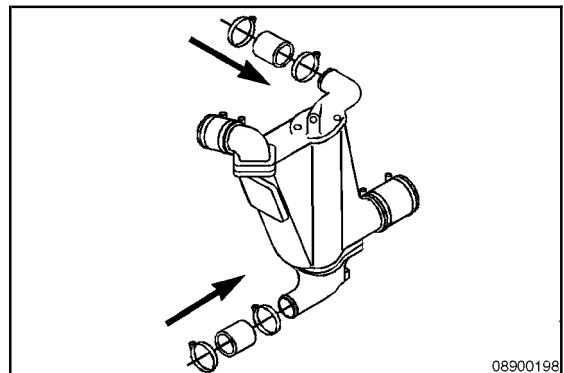

**7/8 Inch**

Install the zinc plug in the aftercooler lower water header.  
 Open the raw water inlet valve.

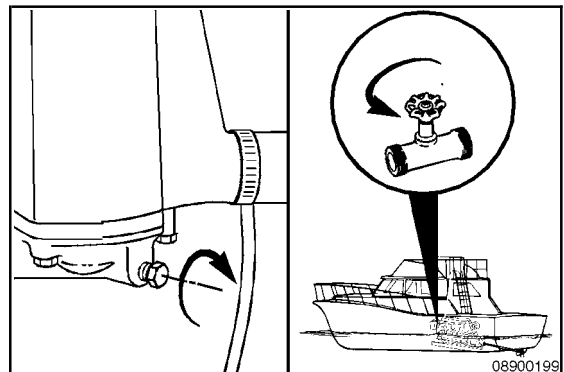

## Sea Water Pump (008-057)

### General Information

**NOTE:** Most sea water systems for heat exchanger-cooled engines use a sea water strainer. The strainer removes debris from the sea water before it enters the sea water pump.

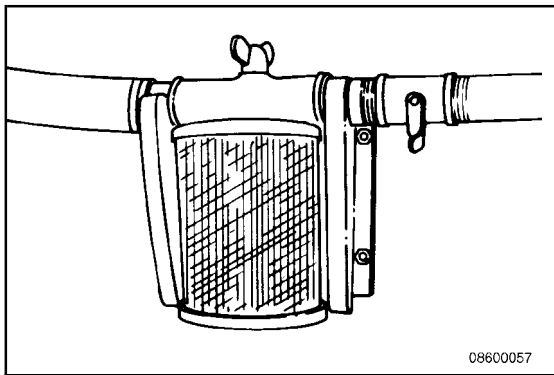

08600057

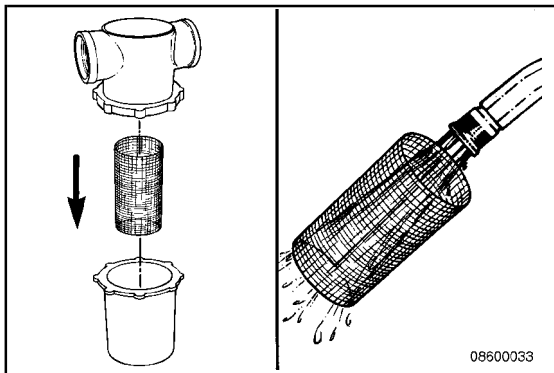

08600033



Typical sea water strainer arrangement.

Inspect the sea water strainer daily for any foreign objects that can restrict water flow.

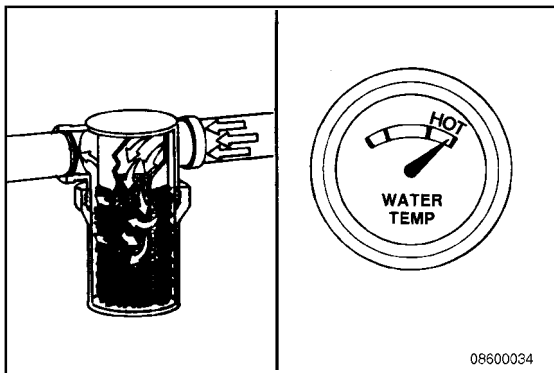

08600034



### CAUTION

A restricted or clogged sea water strainer can result in hotter than normal, or overheated, engine coolant and marine gear oil temperatures.

For more detailed information, refer to Sea Water Strainer Cleaning in this section.

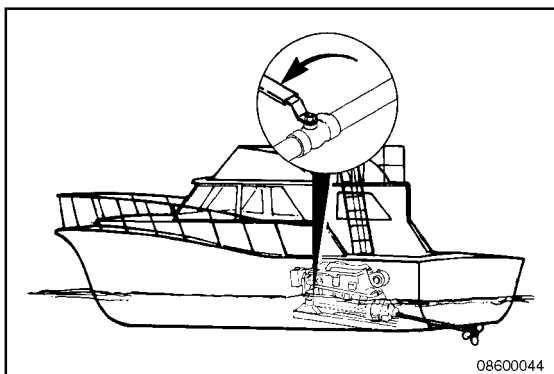

08600044

**NOTE:** If the sea water strainer is below water level, close the sea water inlet valves before servicing the sea water strainer.

**Inspect (008-057-062)**

1/2 Inch

Shut off the raw water inlet valve on the vessel hull.  
Remove the pump cover plate.

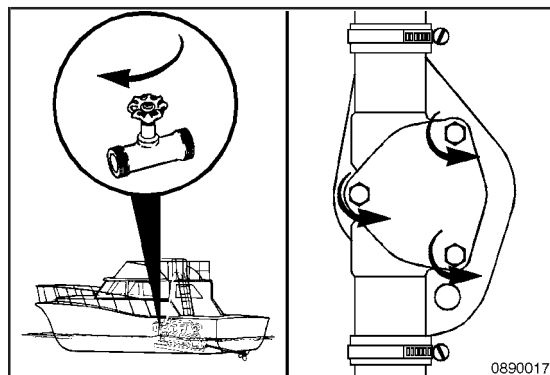

08900171

**NOTE:** It can be necessary to remove the impeller to examine for chunking or torn vanes.

If the impeller appears **not** to be damaged, clean and install the cover plate.

If damaged vanes are evident, refer to the OEM service manual.

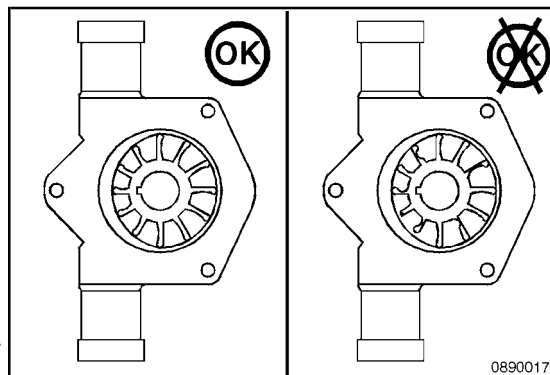

08900172

Use a 4.76 mm [3/16 in] diameter brass rod to clean out any buildup in the cooler tubes.

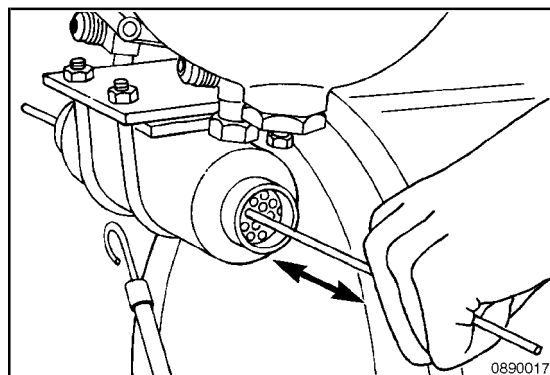

08900173

Use clean water to flush all debris from the cooler.

Be sure that the debris flushed from the cooler does **not** enter the water supply pipe.

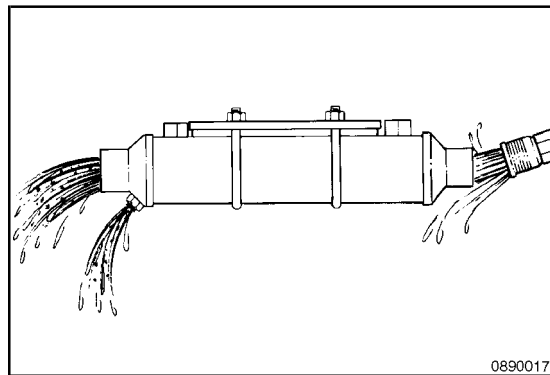

08900174

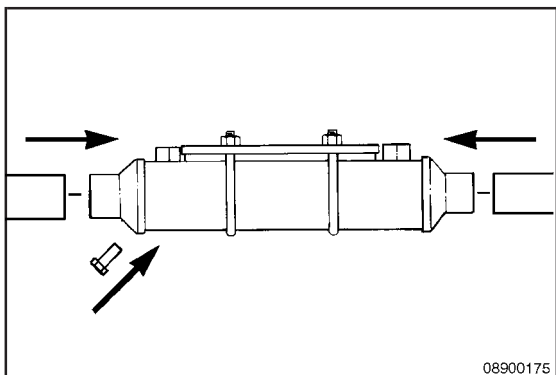

**7/16-Inch and 5/16-Inch Nutdriver**

Install the drain plug and water connections.



Open the sea water valve on the vessel hull, if closed.

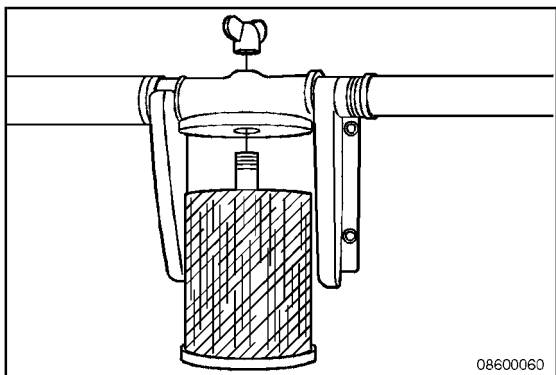

**Disassemble (008-057-003)**

Loosen and remove the sea water strainer wing nut(s) as required.

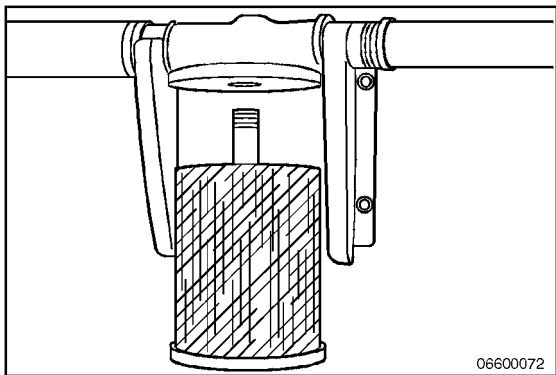

Remove the sea water strainer assembly. Be careful **not** to damage the o-ring. Retain and inspect for damage.

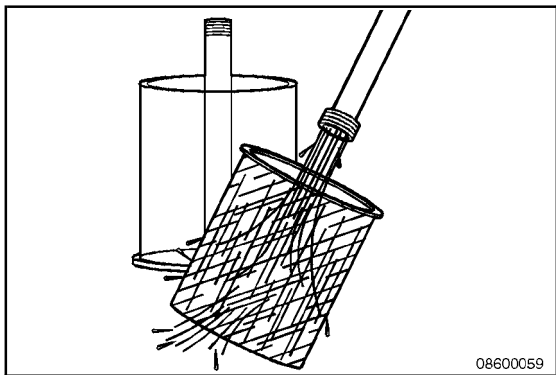

**Clean (008-057-006)**

Empty all debris from the sea water strainer basket.  
Clean the sea water strainer.

**Assemble (008-057-025)**

Install the sea water strainer.

Inspect the o-ring seal for tears or damage. Replace if necessary. Be sure the o-ring is seated properly.

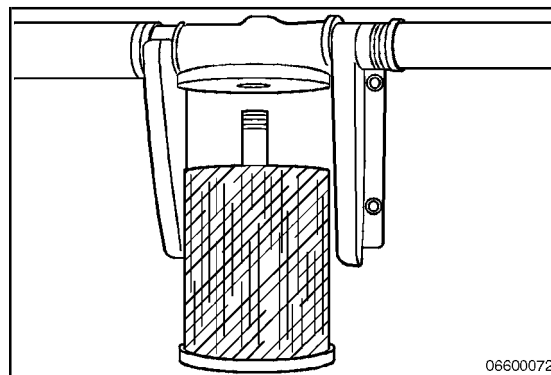

06600072

Install and tighten the wing nut(s).

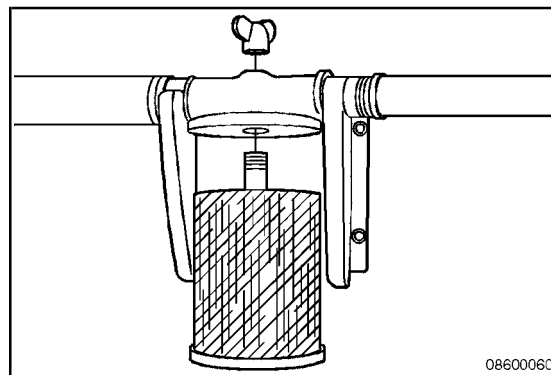

08600060

Open the sea water inlet valves.

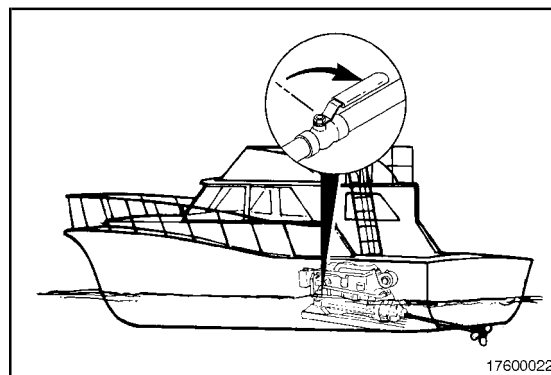

17600022

**Water Pump (008-062)**

**Preparatory (008-062-000)**



**WARNING**

Coolant is toxic. If not reused, dispose of in accordance with local environmental regulations.

- Drain the coolant. Refer to Procedure 008-018.

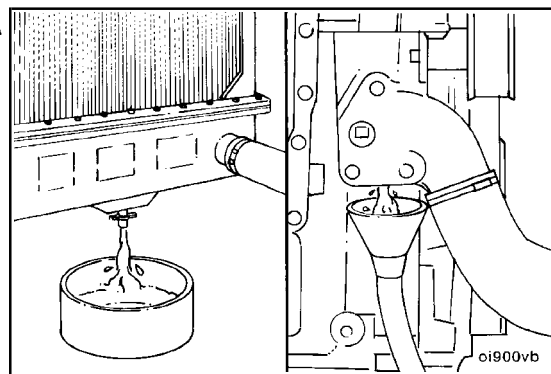

0i900vb

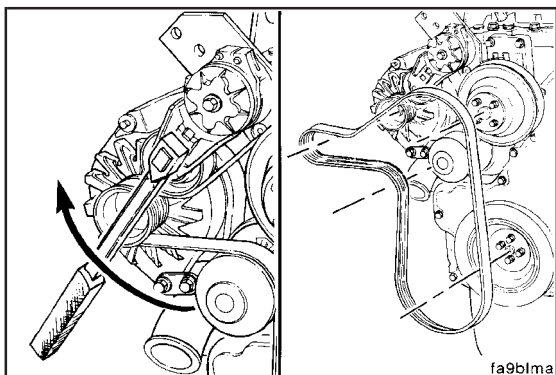

**Remove (008-062-002)**

Remove the drive belt. Refer to Procedure 008-002.

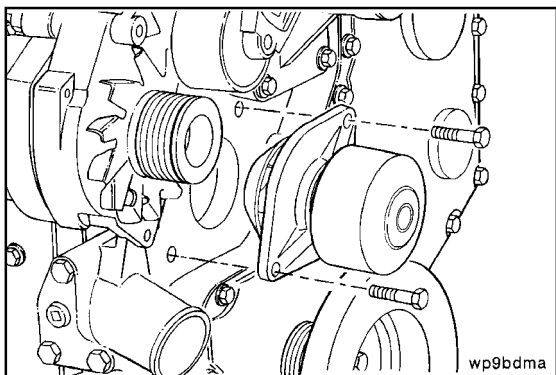

**13 mm**

Remove the two capscrews and water pump.

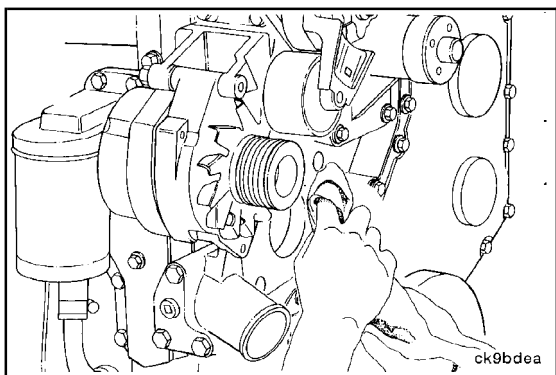

**Clean (008-062-006)**

Clean the sealing surface on the cylinder block.

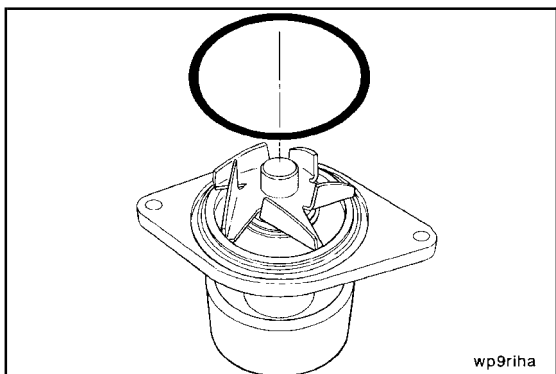

Clean o-ring sealing surface on the water pump housing.

Install the o-ring onto the water pump housing





**Inspect for Reuse (008-062-007)**

Inspect the water pump body for indications of water leakage at the weep hole.

A streak or chemical buildup at the weep hole is **not** justification for water pump replacement. If a recurring drip of coolant is observed, replace the water pump with a new unit.

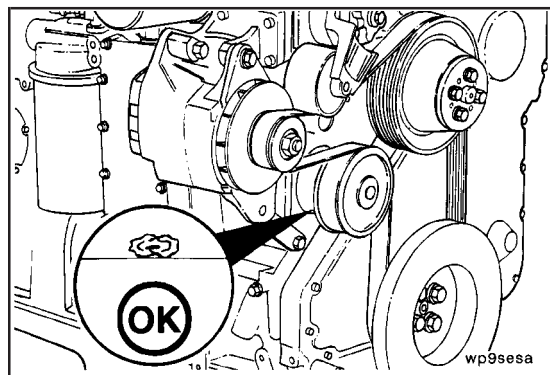

Inspect the weep hole to make sure it is open. A plugged weep hole can cause the water pump to fail.

A small screwdriver or a small tool can be used to remove any debris.

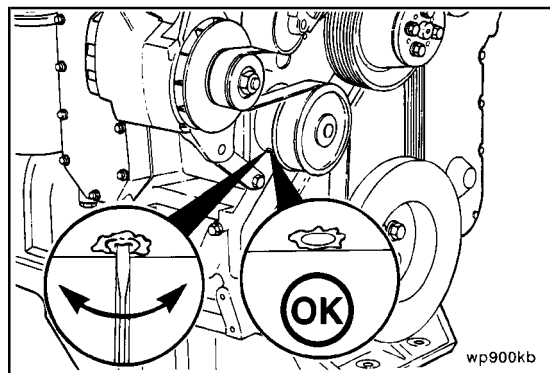

Inspect the o-ring sealing surface of housing.

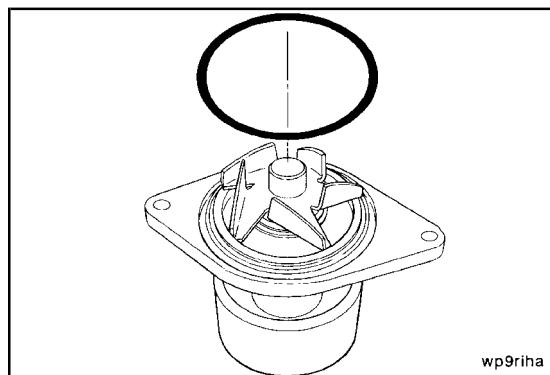

**Install (008-062-026)**

Install the new sealing ring into the pump groove.

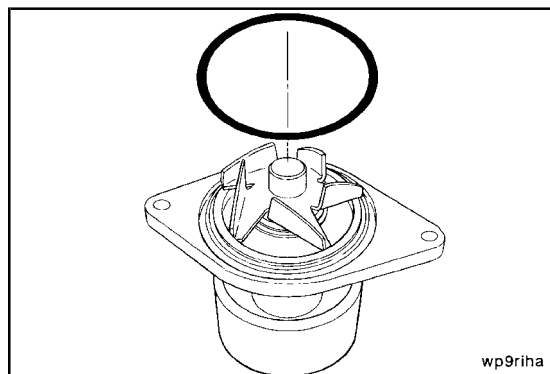

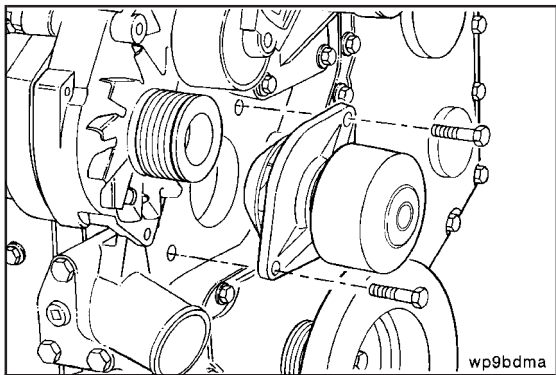

13 mm

Install the water pump.



**Torque Value:** 24 N•m [18 ft-lb]

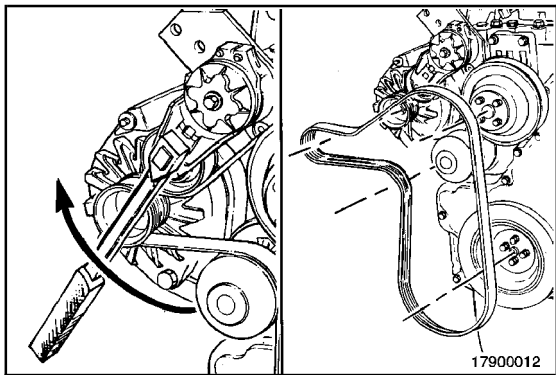

**3/8-Inch Square Drive**

Lift the tensioner and install the belt. Refer to Procedure 008-002.



**Service Tip:** If difficulty is experienced installing the drive belt, such as the belt seems too short, position the belt over the grooved pulleys first; then, while holding the tensioner up, slide the belt over the water pump pulley.

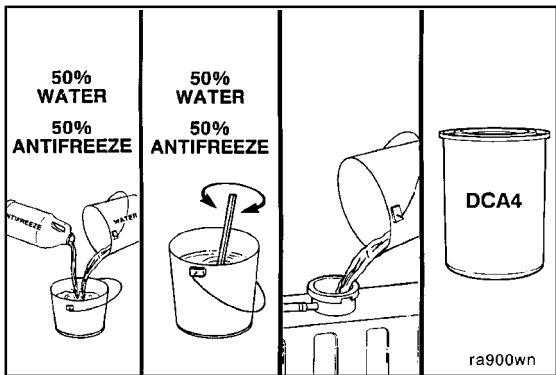

Fill the cooling system. Refer to Procedure 008-018.

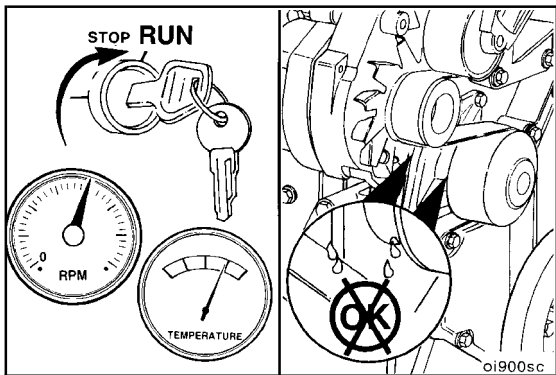

Install the pressure cap. Operate the engine and check for coolant leaks.

**Engine Temperature:** 80 °C [180 °F]



### Coolant Temperature Sensor, OEM (008-070)

#### Preparatory (008-070-000)



**WARNING**

Coolant is toxic. Keep away from pets and children. If not reused, dispose of in accordance with local environmental regulations.



**WARNING**

Do not remove the pressure cap from a hot engine. Wait until the temperature is below 50°C [122°F] before removing the pressure cap. Heated coolant spray or steam can cause personal injury.

- Drain the coolant. Refer to Procedure 008-018.

#### Remove (008-070-002)

10 mm or Screwdriver

Disconnect the temperature sensor wiring.

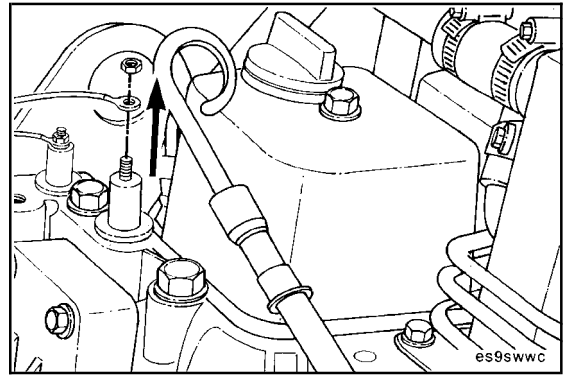
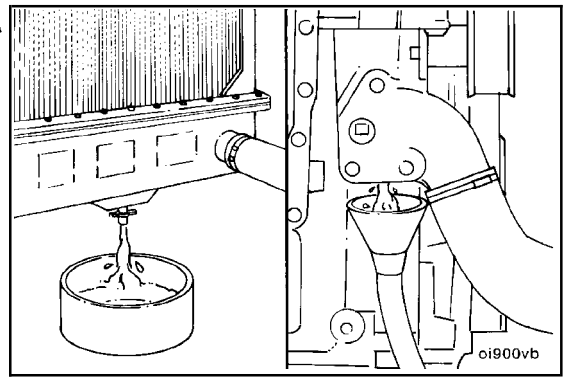

22 mm

Remove the temperature sensor.

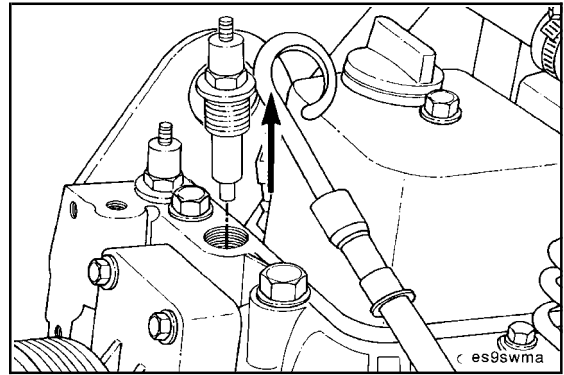

#### Inspect for Reuse (008-070-007)

Check for continuity. The sensor will have continuity **only** when coolant temperature is reached.

Sensor: 107 °C [225 °F]

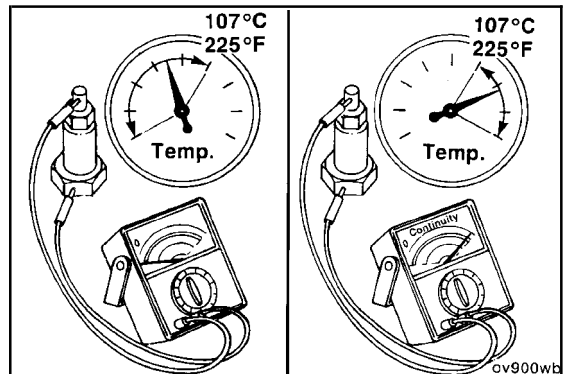

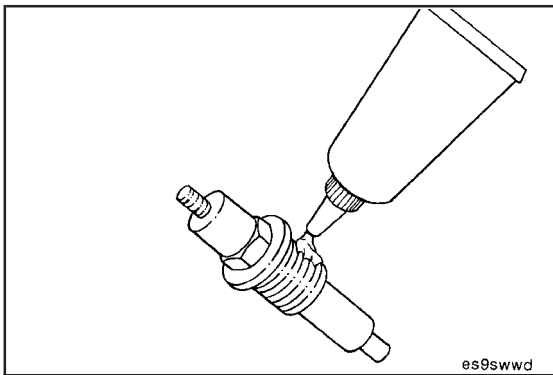

**Install (008-070-026)**

22 mm



Apply liquid teflon sealant to the threads when installing the temperature sensor.

Reconnect the wiring.



**Torque Value:**

(Installed into Cast Iron)	50 N•m	[37 ft-lb]
(Installed into Aluminum)	30 N•m	[22 ft-lb]



Fill coolant to proper level. Refer to Procedure 008-018.

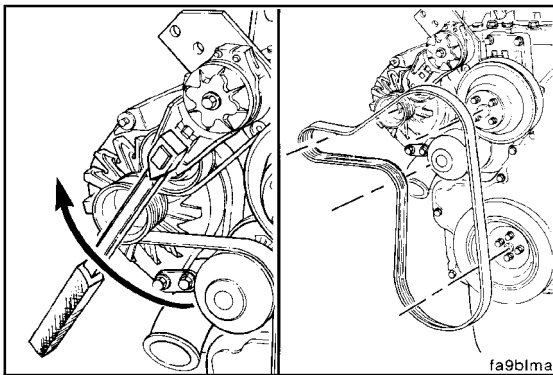

**Fan Belt Tensioner (008-087)**

**Preparatory (008-087-000)**



- Remove the drive belt. Refer to Procedure 008-002.

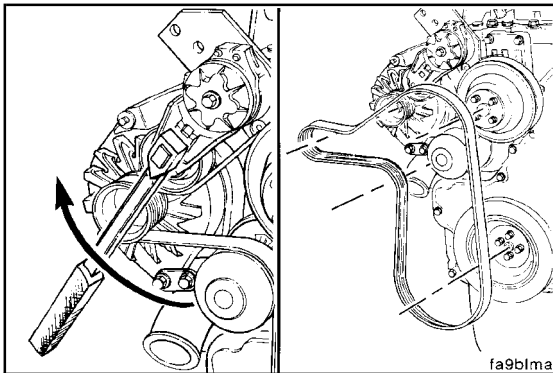

**Remove (008-087-002)**

3/8-Inch Square Drive



Lift belt tensioner to relieve tension in the belt, and remove the belt.

**NOTE:** The belt tensioner is spring loaded and **must** be pivoted away from the drive belt. Pivoting in the wrong direction can result in damage to the belt tensioner.

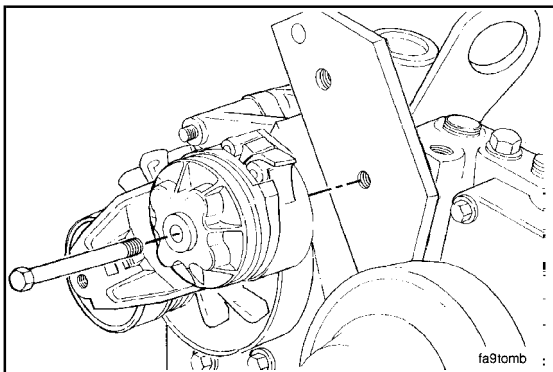

15 mm

Remove the capscrew and belt tensioner from the bracket.



**Install (008-087-026)**

15 mm

Install the tensioner and capscrews.

**Torque Value:** 43 N•m [32 ft-lb]

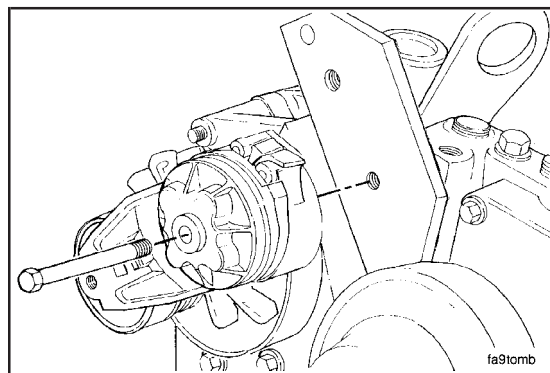

**3/8-Inch Square Drive**

Lift and hold the tensioner. Install the drive belt and release the tensioner. Refer to Procedure 008-002 for drive belt procedure.

**Service Tip:** If difficulty is experienced installing the drive belt; for example, the belt seems too short; position the belt over the grooved pulleys first; then, while holding the tensioner up, slide the belt over the water pump pulley.

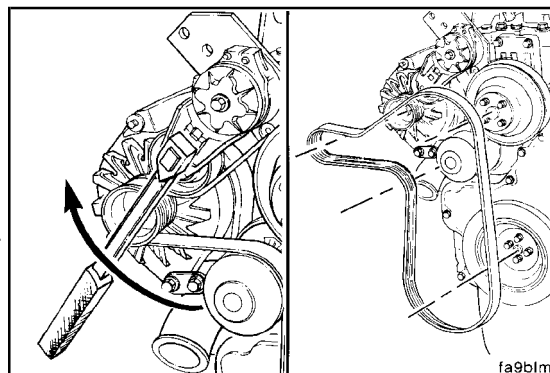



# Section 9 - Drive Units - Group 09

## Section Contents

	<b>Page</b>
<b>Hydraulic Pump Drive</b> .....	9-1
Clean .....	9-1
Inspect for Reuse .....	9-2
Install .....	9-2
Remove .....	9-1
<b>Hydraulic Pump Drive Gear and Shaft</b> .....	9-3
Inspect for Reuse .....	9-3

**THIS PAGE LEFT INTENTIONALLY BLANK**



### Hydraulic Pump Drive (009-016)

#### Remove (009-016-002)

Disconnect all hydraulic lines from the pump.

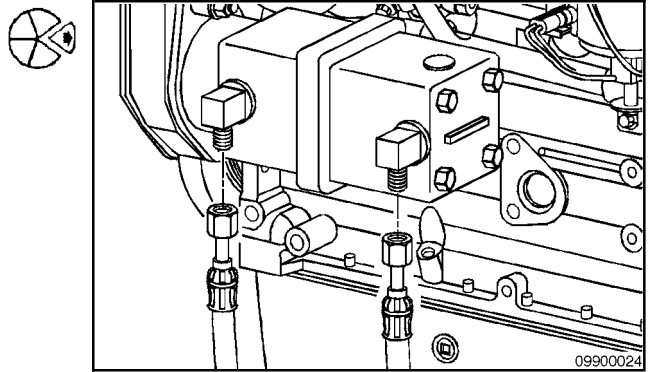

**NOTE:** Refer to the OEM service manual for removal procedures.

Remove the hydraulic pump and gear assembly.

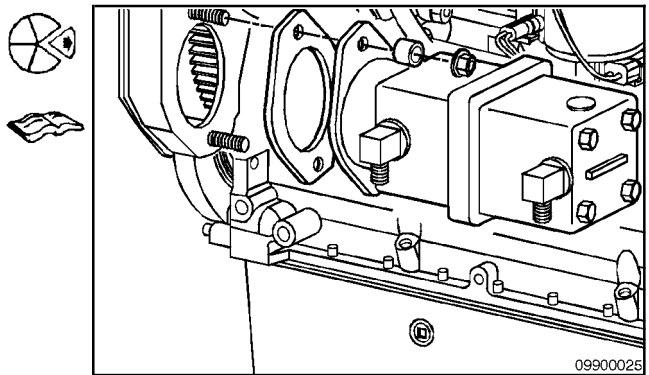

#### Clean (009-016-006)

Clean the gasket material from the hydraulic pump with a putty knife and a clean cloth.

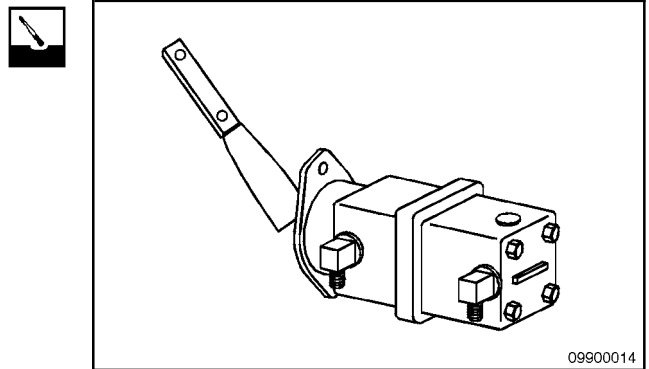

**▲ WARNING ▲**

When using solvents, acids, or alkaline materials for cleaning, follow the manufacturer's recommendations for use. Wear goggles and protective clothing to avoid personal injury.

**▲ WARNING ▲**

Compressed air used for cleaning should not exceed 207 kPa [30 psi]. Use only with protective equipment (goggles/shield, gloves, and so forth) to avoid personal injury.

Clean the hydraulic pump gear with solvent.

Dry with compressed air.

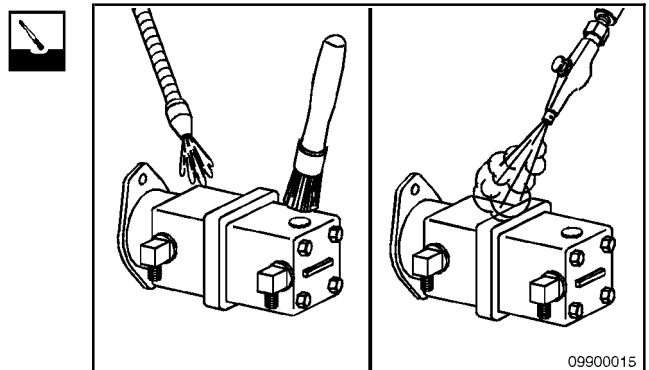

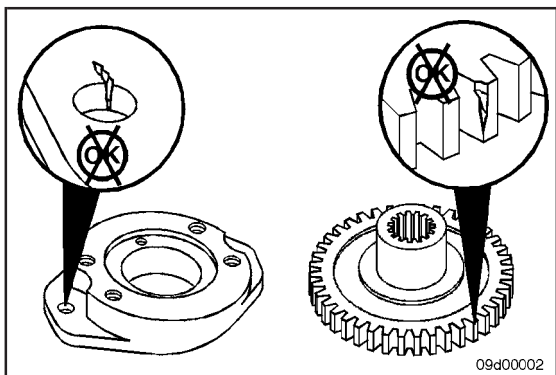

**Inspect for Reuse (009-016-007)**

Inspect the hydraulic pump drive gear for damage.

Refer to Procedure 009-019.

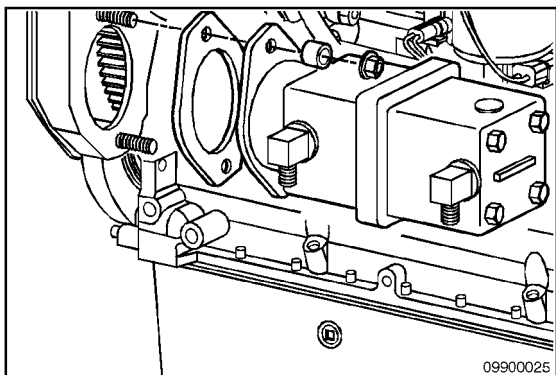

**Install (009-016-026)**

Use a new gasket and install the hydraulic pump.

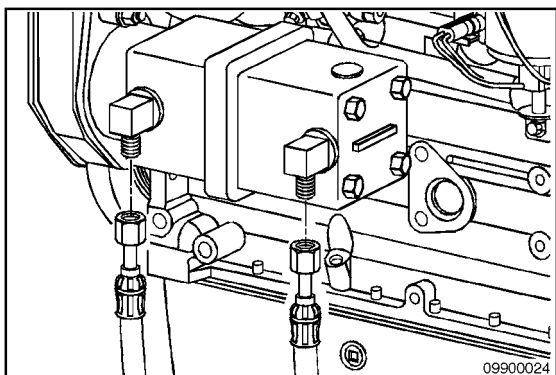

Connect all hydraulic lines to the pump.

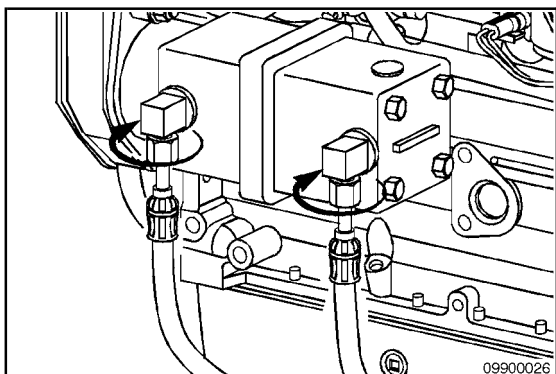

Tighten mounting bolts.

**Torque Value:** 77 N•m [57 ft-lb]

### Hydraulic Pump Drive Gear and Shaft (009-019)

#### Inspect for Reuse (009-019-007)

Inspect for damage such as cracks, broken teeth, and damaged threads.

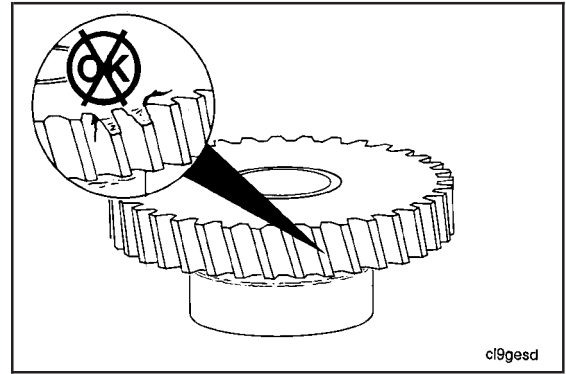

ci9gesd

Rotate the gear, and inspect for rough spots in the bearing bore and excessive wear.

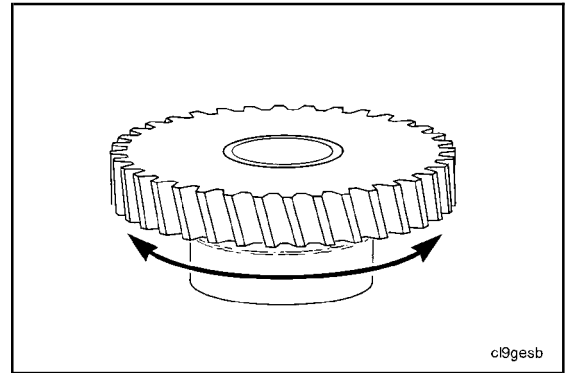

ci9gesb



## Section 10 - Air Intake System - Group 10

### Section Contents

	Page
<b>Aftercooler</b> .....	10-15
Clean.....	10-15
Fill .....	10-16
Install.....	10-16
Preparatory.....	10-15
Remove .....	10-15
<b>Air Crossover</b> .....	10-16
Inspect for Reuse .....	10-17
Install.....	10-17
Remove .....	10-16
<b>Air Intake Manifold</b> .....	10-17
Clean.....	10-18
Inspect for Reuse .....	10-18
Install.....	10-18
Preparatory.....	10-17
Remove .....	10-18
<b>Air Intake Manifold Heater</b> .....	10-52
General Information .....	10-52
Install.....	10-64
Maintenance Check .....	10-61
Remove .....	10-63
<b>Air Intake Restriction</b> .....	10-26
General Information .....	10-26
Measure .....	10-27
<b>Air Intake System - General Information</b> .....	10-14
<b>Air Leaks, Air Intake and Exhaust Systems</b> .....	10-19
Initial Check.....	10-19
<b>Charge-Air Cooler (CAC)</b> .....	10-22
Clean.....	10-22
General Information .....	10-22
Inspect for Reuse .....	10-23
Leak Test .....	10-24
Pressure Test.....	10-24
Temperature Differential Test.....	10-25
<b>Flow Diagram, Air Intake System</b> .....	10-3
<b>Service Tools</b> .....	10-1
Air Intake System.....	10-1
<b>Specifications</b> .....	10-7
Air Intake System .....	10-7
<b>Turbocharger</b> .....	10-29
Clean.....	10-33
General Information .....	10-29
Inspect for Reuse .....	10-33
Install.....	10-35
Measure .....	10-34
Remove .....	10-31
<b>Turbocharger Axial Clearance</b> .....	10-37
Measure .....	10-37
<b>Turbocharger Blade Damage</b> .....	10-38
Inspect for Reuse .....	10-38
<b>Turbocharger Compressor Seal Leaks</b> .....	10-39
Leak Test.....	10-39
<b>Turbocharger Oil Drain Line</b> .....	10-40
Clean.....	10-40

	Page
Initial Check.....	10-40
Inspect for Reuse .....	10-40
Install.....	10-41
Remove .....	10-40
<b>Turbocharger Oil Supply Line .....</b>	<b>10-41</b>
Initial Check.....	10-41
Inspect for Reuse.....	10-41
Install.....	10-42
Remove .....	10-41
<b>Turbocharger Radial Bearing Clearance .....</b>	<b>10-42</b>
Measure .....	10-42
<b>Turbocharger Turbine Seal Leaks.....</b>	<b>10-43</b>
Leak Test .....	10-43
<b>Turbocharger Wastegate Actuator .....</b>	<b>10-45</b>
Calibrate.....	10-49
Initial Check.....	10-45
Inspect for Reuse .....	10-47
Install.....	10-48
Remove .....	10-46
Test.....	10-48
<b>Turbocharger Wastegate Valve Body .....</b>	<b>10-50</b>
Inspect for Reuse .....	10-50

## Service Tools

### Air Intake System

The following special tools are recommended to perform procedures in this section. The use of these tools is shown in the appropriate procedure. These tools can be purchased from your local Cummins Authorized Repair Location.

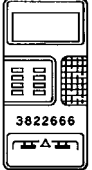
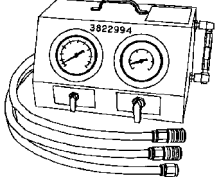
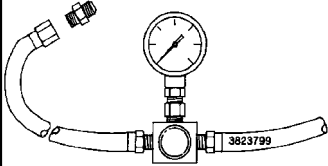
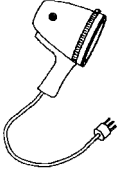
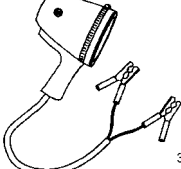
Tool No.	Tool Description	Tool Illustration
3376891	<p><b>Flourescent Tracer</b> Used with black light to find oil leaks. Mixed with engine oil.</p>	 <p style="text-align: right;">3376891</p>
3822666	<p><b>Fluke Digital Thermometer</b> Used to measure ambient air temperature.</p>	 <p style="text-align: right;">3822666</p>
3822988	<p><b>Thermocouple Wide Kit</b> Used with the fluke digital thermometer, Part No. 3822666.</p>	 <p style="text-align: right;">3822988</p>
3823799	<p><b>Turbocharger Wastegate Pressure Setting Kit</b> Used to set wastegate pressure.</p>	 <p style="text-align: right;">3823799</p>
3824524	<p><b>Black Light (AC)</b> Used to inspect for oil or fuel leak.</p>	 <p style="text-align: right;">3377253</p>
3824754	<p><b>Black Light (DC)</b> Used to inspect for oil or fuel leak.</p>	 <p style="text-align: right;">3377394</p>

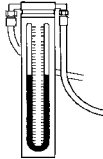
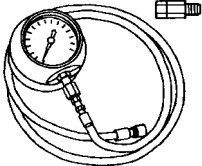
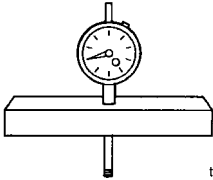
Tool No.	Tool Description	Tool Illustration
ST1111-3	<p><b>Manometer</b> Used to measure pressure, restriction (0 to 10 in H<sub>2</sub>O) pressure differential with more accuracy.</p>	 <p style="text-align: right; font-size: small;">eg100a</p>
ST1273	<p><b>Pressure Gauge [0 to 75 in Hg]</b> Used to measure the intake manifold pressure and exhaust back pressure.</p>	 <p style="text-align: right; font-size: small;">eg8togi</p>
ST537	<p><b>Dial Depth Gauge</b> Used to measure turbocharger axial motion.</p>	 <p style="text-align: right; font-size: small;">tb8togf</p>



### Flow Diagram, Air Intake System

**Insert Color File**  
10900254.CDR  
Pantone 299 (Blue)

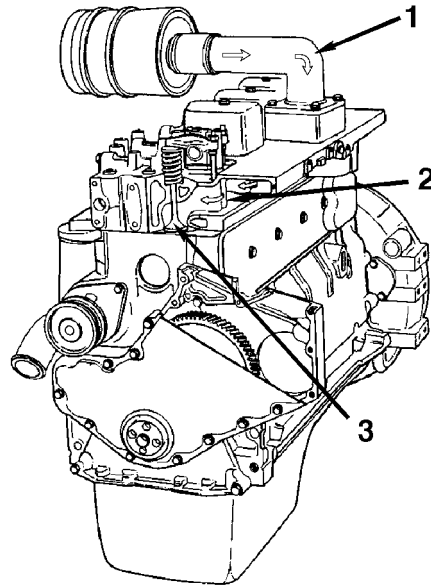

10900254

**Naturally Aspirated Engine**

- 1. Intake Air Inlet
- 2. Intake Manifold
- 3. Intake Valve.

**Insert Color File**  
10900255.CDR  
Pantone 299 (Blue)

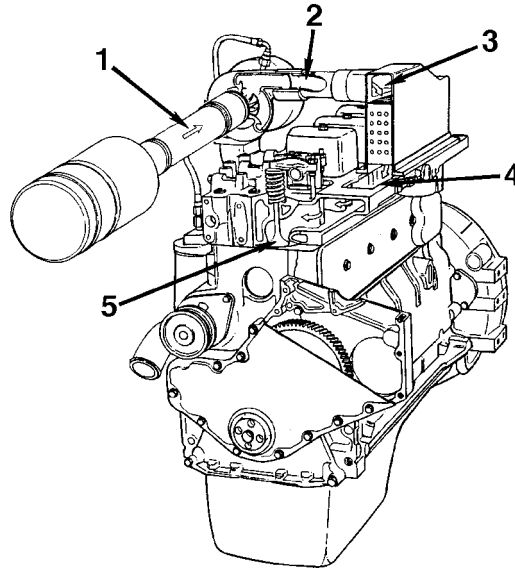

10900255

**Turbocharged-Aftercooled (Water Jacket) Engine**

- |                                     |                    |
|-------------------------------------|--------------------|
| 1. Intake Air Inlet to Turbocharger | 4. Intake Manifold |
| 2. Turbocharger Air to Aftercooler  | 5. Intake Valve.   |
| 3. Aftercooler                      |                    |

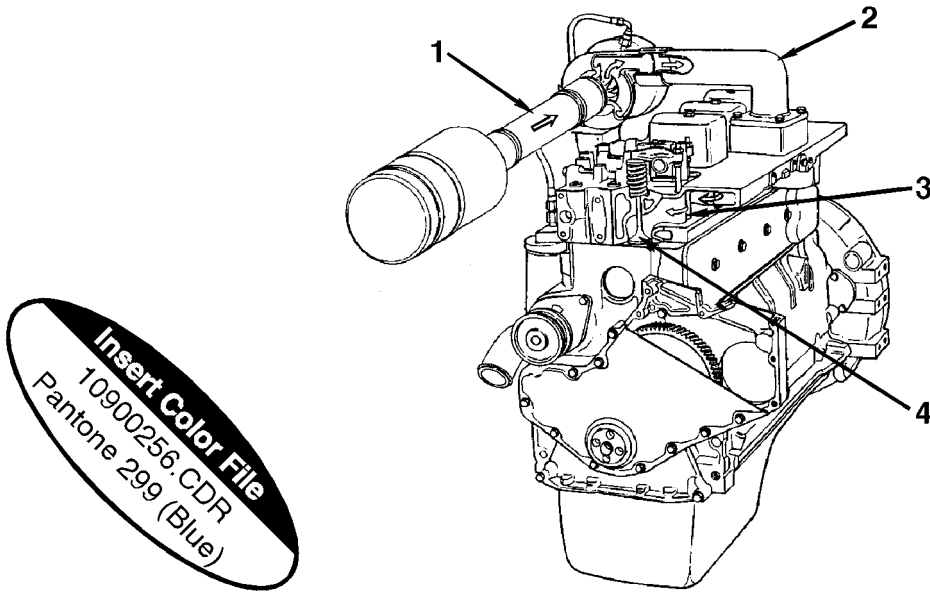

10900256

**Turbocharged Engine**

1. Intake Air Inlet to Turbocharger
2. Air to Intake Manifold
3. Intake Manifold
4. Intake Valve.

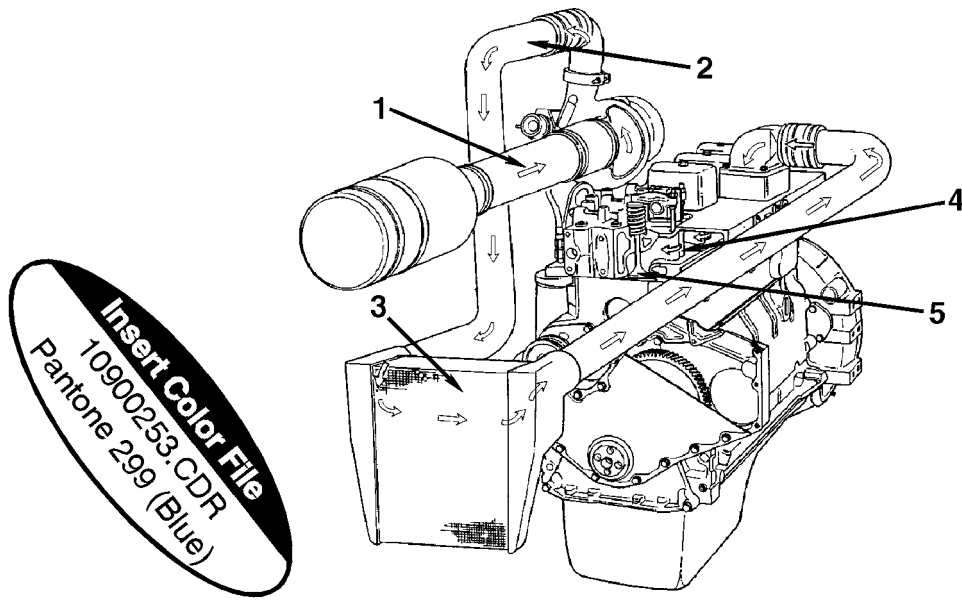

10900253

**Turbocharged-Charge-Air-Cooled**

- |  |                    |
|--|--------------------|
| 1. Intake Air Inlet to Turbocharger      | 4. Intake Manifold |
| 2. Turbocharger Air to Charge Air Cooler | 5. Intake Valve.   |
| 3. Charge Air Cooler                     |                    |

## Specifications

### Air Intake System

#### Air Intake System Data (automotive)

	B3.9	B5.9
Maximum Allowable Intake Restriction at Rated Speed and Loaded with Dirty Air Filter Element	635 mm H <sub>2</sub> O [25 in H <sub>2</sub> O]	635 mm H <sub>2</sub> O [25 in H <sub>2</sub> O]

**4B Air Intake System (nonautomotive)**

	<b>4B3.9</b>	<b>4BT3.9</b>	<b>4BTA3.9</b>
Maximum Allowable Intake Restriction at Rated Speed and Loaded with Dirty Air Filter Element	508 mm H <sub>2</sub> O [20 in H <sub>2</sub> O]	635 mm H <sub>2</sub> O [25 in H <sub>2</sub> O]	635 mm H <sub>2</sub> O [25 in H <sub>2</sub> O]

**6B Air Intake System (nonautomotive)**

	<b>6B5.9</b>	<b>6BT5.9</b>	<b>6BTA5.9</b>
Maximum Allowable Intake Restriction at Rated Speed and Loaded with Dirty Air Filter Element	508 mm H <sub>2</sub> O [20 in H <sub>2</sub> O]	635 mm H <sub>2</sub> O [25 in H <sub>2</sub> O]	635 mm H <sub>2</sub> O [25 in H <sub>2</sub> O]

Refer to the following table for the control parts list (CPL), engine model, engine horsepower rating, and corresponding rated turbocharger boost pressure.

**NOTE:** Measurement of boost pressure is **not** a shortcut to logical troubleshooting. Low power can be caused by the fuel used, filter maintenance, and several engine components. Follow the logic charts for Engine Power Output Low, and measure boost pressure as indicated. Refer to this section, General Information, for measurement instructions.

These pressures are valid **only** at rated conditions (rated speed and power). Any attempt to use the values at engine speeds and loads other than those specified will result in an incorrect diagnosis.

**B Series Engines' Turbocharger Boost Pressure Specifications**

CPL	MODEL EN-GINE	hp @ rpm RATING	PEAK TORQUE ft-lb @ rpm	RATED BOOST (in Hg)			PEAK TORQUE BOOST (in Hg)		
				min	nom	max	min	nom	max
591	4B3.9	64 @ 2200	N/A	N/A	N/A	N/A	N/A	N/A	N/A
591	4B3.9	64 @ 2200	N/A	N/A	N/A	N/A	N/A	N/A	N/A
592	4BTA3.9	70 @ 2100	N/A	11	14	17	N/A	N/A	N/A
592	4BTA3.9	71 @ 2200	N/A	12	15	18	N/A	N/A	N/A
592	4BTA3.9	80 @ 2200	N/A	14	17	20	N/A	N/A	N/A
592	4BTA3.9	92 @ 2100	N/A	16	19	22	N/A	N/A	N/A
592	4BTA3.9	93 @ 2200	N/A	18	21	24	N/A	N/A	N/A
592	4BTA3.9	94 @ 2200	N/A	18	21	24	N/A	N/A	N/A
592	4BTA3.9	96 @ 2300	N/A	19	22	25	N/A	N/A	N/A
592	4BTA3.9	100 @ 2500	N/A	22	25	28	N/A	N/A	N/A
594	4BTA3.9	95 @ 2200	N/A	15	18	21	N/A	N/A	N/A
594	4BTA3.9	112 @ 2300	N/A	21	24	27	N/A	N/A	N/A
594	4BTA3.9	125 @ 2200	N/A	25	28	31	N/A	N/A	N/A
646	4BT3.9	71 @ 1500	N/A	9	12	15	N/A	N/A	N/A
646	4BT3.9	82 @ 1800	N/A	11	14	17	N/A	N/A	N/A
710	4BT3.9	75 @ 2200	N/A	13	16	19	N/A	N/A	N/A
710	4BT3.9	100 @ 2500	N/A	22	25	28	N/A	N/A	N/A
711	4BT3.9	71 @ 1500	N/A	9	12	15	N/A	N/A	N/A
711	4BT3.9	82 @ 1800	N/A	11	14	17	N/A	N/A	N/A
721	4B3.9	80 @ 2800	N/A	N/A	N/A	N/A	N/A	N/A	N/A
730	4BT3.9	85 @ 2500	235 @ 1200	17	20	23	9	10	11
730	4BT3.9	91 @ 2200	259 @ 1400	17	20	23	11	12	13
741	4BT3.9	130 @ 2500	N/A	18	21	24	N/A	N/A	N/A
741	4BT3.9	150 @ 2800	N/A	25	28	31	N/A	N/A	N/A
741	4BT3.9	150 @ 2800	N/A	25	28	31	N/A	N/A	N/A
762	4BT3.9	105 @ 2500	N/A	28	32	36	N/A	N/A	N/A
762	4BT3.9	105 @ 2800	N/A	31	35	39	N/A	N/A	N/A
763	4BT3.9	67 @ 2200	N/A	10	14	16	N/A	N/A	N/A
763	4BT3.9	71 @ 2200	N/A	10	14	16	N/A	N/A	N/A
767	4BT3.9	105 @ 2500	N/A	24	28	31	N/A	N/A	N/A
767	4BT3.9	105 @ 2800	N/A	27	30	33	N/A	N/A	N/A
826	4BT3.9	87 @ 1500	N/A	15	18	21	N/A	N/A	N/A
857	4BT3.9	120 @ 2500	N/A	40	44	48	N/A	N/A	N/A
858	4BT3.9	105 @ 2500	N/A	35	39	43	N/A	N/A	N/A
937	4BT3.9	74 @ 1500	N/A	10	13	16	N/A	N/A	N/A
971	4BT3.9	96 @ 2200	N/A	19	22	25	N/A	N/A	N/A
971	4BT3.9	100 @ 2500	N/A	22	25	28	N/A	N/A	N/A
986	4BTA3.9	120 @ 2500	N/A	28	31.0	34	17	19.4	21
1201	4BT3.9	80 @ 2500	N/A	19	22	25	N/A	N/A	N/A
1202	4BT3.9	74 @ 2500	N/A	18	21	24	N/A	N/A	N/A
1260	4BTA3.9	105 @ 2500	N/A	22	24.5	27	14	15.6	17
1268	4BT3.9	105 @ 2500	N/A	28	32	36	N/A	N/A	N/A
1520	4BTG2	104 @ 1800	N/A	19	21	23	N/A	N/A	N/A
1521	4BT3.9	74 @ 1500	N/A	3.4	6.4	9.4	N/A	N/A	N/A

(Continued)

CPL	MODEL EN-GINE	hp @ rpm RATING	PEAK TORQUE ft-lb @ rpm	RATED BOOST (in Hg)			PEAK TORQUE BOOST (in Hg)		
				min	nom	max	min	nom	max
1521	4BT3.9	86 @ 1800	N/A	5.8	8.8	12.0	N/A	N/A	N/A
1521	4BT3.9	88 @ 1800	N/A	19	21	23	N/A	N/A	N/A
1525	4BT3.9	72 @ 1500	N/A	N/A	N/A	N/A	N/A	N/A	N/A
1525	4BTG2	87 @ 1500	N/A	12	13	14	N/A	N/A	N/A
1963	4BTA3.9	116 @ 2500	295 @ 1500	36	39.3	42	23	25.6	29
1963	4BTA3.9	116 @ 2500	299 @ 1500	37	39.9	43	23	26	29
1963	4BTA3.9	125 @ 2200	350 @ 1500	37	40	43	29	32	35
1963	4BTA3.9	130 @ 2500	344 @ 1500	36	39	42	27	30	33
1965	4BT3.9	80 @ 2200	229 @ 1500	39	42	45	17	20	23
1965	4BT3.9	85 @ 2200	242 @ 1500	43	46	49	19	22	25
1965	4BTA3.9	85 @ 2200	254 @ 1500	43	46	49	19	22	25
1965	4BT3.9	90 @ 2200	269 @ 1500	45	49	53	22	26	30
1965	4BT3.9	92 @ 2100	293 @ 1500	46	49.3	52	28	31	34
1965	4BT3.9	92 @ 2100	295 @ 2100	45	49	53	25	29	33
1966	4BT3.9	92 @ 2000	302 @ 1300	31	33.7	37	20	22.7	26
1967	4BT3.9	85 @ 2500	239 @ 1500	38	41.5	45	16	20	24
1967	4BT3.9	90 @ 2500	254 @ 1500	38	42	45	20	24	28
1967	4BT3.9	95 @ 2200	285 @ 1500	38	42.2	45	24	27.9	32
1967	4BT3.9	100 @ 2200	298 @ 1500	41	44	47	27	30	33
1967	4BT3.9	105 @ 2100	293 @ 1500	39	42.3	45	26	29.2	32
1967	4BT3.9	105 @ 2400	280 @ 1500	41	44.3	47	23	26.6	31
1967	4BT3.9	110 @ 2500	293 @ 1500	42	44.8	48	25	29	33
2021	4BT3.9	93 @ 2200	353 @ 1550	N/A	N/A	N/A	N/A	N/A	N/A
2109	4BTA3.9	107 @ 2100	327 @ 1500	40	42.7	46	30	32.5	36
2109	4BTA3.9	107 @ 2100	334 @ 1500	39	42	45	30	33	36
2109	4BTA3.9	107 @ 2100	328 @ 1600	40	42.7	46	30	32.5	36
2109	4BTA3.9	110 @ 2200	328 @ 1500	39	42	45	30	33	36
2109	4BTA3.9	110 @ 2200	328 @ 1500	39	42.0	45	30	33	36
2109	4BTA3.9	110 @ 2200	333 @ 1500	39	41.7	45	30	33.3	36
2109	4BTA3.9	116 @ 2500	300 @ 1500	39	42	45	29	32	35
2109	4BTA3.9	116 @ 2500	312 @ 1500	40	43	46	29	32	35
2264	4BTA3.9	125 @ 2200	355 @ 1500	36	39	42	29	32	35
2302	4BT3.9	110 @ 2500	278 @ 1500	41	43.7	47	24	26.6	30
2302	4BT3.9	110 @ 2500	278 @ 1500	40	43	46	23	26	29
2302	4BT3.9	110 @ 2500	293 @ 1500	41	43.7	47	26	28.6	32
2351	4BTA3.9	110 @ 2200	328 @ 1500	37	39.9	43	27	29.5	33
2359	4BT3.9	85 @ 2500	239 @ 1500	39	41.5	45	17	20	23
2361	4B3.9	74 @ 2500	201 @ 1200	N/A	N/A	N/A	N/A	N/A	N/A
2361	4B3.9	80 @ 2500	201 @ 1200	N/A	N/A	N/A	N/A	N/A	N/A
2361	4B3.9	80 @ 2500	201 @ 1200	N/A	N/A	N/A	N/A	N/A	N/A
2374	4B3.9	75 @ 2200	201 @ 1200	N/A	N/A	N/A	N/A	N/A	N/A
2478	4BT3.9	80 @ 2200	229 @ 1500	39	41.8	45	17	20	23
2486	4B3.9	75 @ 2200	201 @ 1200	N/A	N/A	N/A	N/A	N/A	N/A
2488	4B3.9	54 @ 2000	179 @ 1200	N/A	N/A	N/A	N/A	N/A	N/A
2489	4B3.9	60 @ 2200	179 @ 1200	N/A	N/A	N/A	N/A	N/A	N/A
2490	4B3.9	67 @ 2200	192 @ 1200	N/A	N/A	N/A	N/A	N/A	N/A
2599	4B3.9	75 @ 2200	193 @ 1200	N/A	N/A	N/A	N/A	N/A	N/A
2599	4B3.9	80 @ 2500	193 @ 1200	N/A	N/A	N/A	N/A	N/A	N/A
2601	4B3.9	60 @ 2000	180 @ 1200	N/A	N/A	N/A	N/A	N/A	N/A
2601	4 B3.9	60 @ 2000	190 @ 1200	N/A	N/A	N/A	N/A	N/A	N/A
2808	4BT3.9	110 @ 2500	293 @ 1500	41	43.7	47	24	26.6	30
596	6B5.9	93 @ 2200	262 @ 1100	N/A	N/A	N/A	N/A	N/A	N/A
598	6BT5.9	160 @ 2500	N/A	28	32	36	N/A	N/A	N/A
598	6BT5.9	160 @ 2800	N/A	31	35	39	N/A	N/A	N/A
600	6BTA5.9	180 @ 2500	N/A	39	43	47	N/A	N/A	N/A

(Continued)



CPL	MODEL EN-GINE	hp @ rpm RATING	PEAK TORQUE ft-lb @ rpm	RATED BOOST (in Hg)			PEAK TORQUE BOOST (in Hg)		
				min	nom	max	min	nom	max
692	6BT5.9	160 @ 2500	N/A	30	34	38	N/A	N/A	N/A
692	6BT5.9	160 @ 2600	N/A	31	35	39	N/A	N/A	N/A
697	6BT5.9	113 @ 1500	N/A	15	19	21	N/A	N/A	N/A
697	6BT5.9	134 @ 1800	N/A	21	24	27	N/A	N/A	N/A
713	6BT5.9	113 @ 1500	N/A	12	18	21	N/A	N/A	N/A
713	6BT5.9	134 @ 1800	N/A	21	24	27	N/A	N/A	N/A
715	6BTA5.9	143 @ 2100	N/A	26	29	32	N/A	N/A	N/A
716	6BT5.9	156 @ 2500	N/A	45	49	53	N/A	N/A	N/A
728	6BT5.9	128 @ 2800	N/A	19	22	25	N/A	N/A	N/A
728	6BT5.9	130 @ 2650	N/A	19	22	25	N/A	N/A	N/A
729	6BT5.9	134 @ 2200	N/A	23	26	29	N/A	N/A	N/A
742	6BT5.9	152 @ 2500	N/A	30	33	36	N/A	N/A	N/A
742	6BT5.9	180 @ 2500	N/A	39	43	47	N/A	N/A	N/A
742	6BT5.9	210 @ 2600	N/A	47	51	55	N/A	N/A	N/A
766	6BT5.9	160 @ 2500	N/A	28	32	36	N/A	N/A	N/A
766	6BT5.9	160 @ 2800	N/A	31	35	39	N/A	N/A	N/A
791	6B5.9	120 @ 2800	N/A	N/A	N/A	N/A	N/A	N/A	N/A
791	6B5.9	120 @ 2800	N/A	N/A	N/A	N/A	N/A	N/A	N/A
804	6BT5.9	145 @ 2600	N/A	39	43	47	N/A	N/A	N/A
804	6BT5.9	160 @ 2500	N/A	38	41	44	N/A	N/A	N/A
807	6BT5.9	99 @ 2200	N/A	13	16	19	N/A	N/A	N/A
834	6BTA5.9	180 @ 2500	N/A	32	36	40	N/A	N/A	N/A
856	6BTA5.9	180 @ 2500	N/A	46	50	54	N/A	N/A	N/A
912	6BTA5.9	190 @ 2600	N/A	34	38	42	N/A	N/A	N/A
938	6BT5.9	135 @ 2200	442 @ 1400	23	25	28	19	21	23
938	6BT5.9	137 @ 2200	393 @ 1600	18	21	24	16	18	20
938	6BT5.9	140 @ 2200	426 @ 1300	24	27	30	15	17	19
938	6BT5.9	145 @ 2200	425 @ 1500	25	28	31	19	21	23
938	6BT5.9	87 @ 2200	265 @ 1200	10	13	16	5	6	7
938	6BT5.9	97 @ 2200	270 @ 1200	13	16	19	6	7	8
943	6BT5.9	120 @ 2100	N/A	18	21	24	N/A	N/A	N/A
947	6BT5.9	145 @ 2600	N/A	24	27	30	N/A	N/A	N/A
947	6BT5.9	160 @ 2500	N/A	29	33	37	N/A	N/A	N/A
947	6BT5.9	160 @ 2600	N/A	31	35	39	N/A	N/A	N/A
947	6BT5.9	130 @ 2500	N/A	20	23	26	N/A	N/A	N/A
948	6BT5.9	145 @ 2600	N/A	24	27	30	N/A	N/A	N/A
949	6BT5.9	88 @ 2000	N/A	10	13	16	N/A	N/A	N/A
949	6BT5.9	121 @ 2200	N/A	14	17	20	N/A	N/A	N/A
949	6BT5.9	124 @ 2400	N/A	21	24	27	N/A	N/A	N/A
949	6BT5.9	126 @ 2100	N/A	19	22	25	N/A	N/A	N/A
949	6BT5.9	130 @ 2500	N/A	23	26	29	N/A	N/A	N/A
949	6BT5.9	140 @ 2200	N/A	24	27	30	N/A	N/A	N/A
949	6BT5.9	142 @ 2100	N/A	24	24	30	N/A	N/A	N/A
949	6BT5.9	145 @ 2200	N/A	25	28	31	N/A	N/A	N/A
949	6BT5.9	148 @ 2300	N/A	27	30	33	N/A	N/A	N/A
949	6BT5.9	152 @ 2500	N/A	28	32	36	N/A	N/A	N/A
950	6BT5.9	120 @ 2100	N/A	18	21	24	N/A	N/A	N/A
953	6BTA5.9	220 @ 2500	N/A	23	26	29	N/A	N/A	N/A
953	6BTA5.9	250 @ 2600	N/A	44	48	52	N/A	N/A	N/A
961	6BT5.9	115 @ 1500	N/A	16	19	22	N/A	N/A	N/A
961	6BT5.9	135 @ 1800	N/A	22	25	28	N/A	N/A	N/A
970	6BTA-M2	250 @ 2600	N/A	32	36	40	N/A	N/A	N/A
970	6BTA-M2	300 @ 2800	N/A	46	50	54	N/A	N/A	N/A
970	6BTSWA	300 @ 2800	N/A	40	44	48	N/A	N/A	N/A
983	6BTA5.9	157 @ 2500	N/A	35	39	43	N/A	N/A	N/A
983	6BTA5.9	177 @ 2500	N/A	38	42	46	N/A	N/A	N/A

(Continued)

CPL	MODEL EN-GINE	hp @ rpm RATING	PEAK TORQUE ft-lb @ rpm	RATED BOOST (in Hg)			PEAK TORQUE BOOST (in Hg)		
				min	nom	max	min	nom	max
998	6BTA5.9	200 @ 2500	N/A	45	49	53	N/A	N/A	N/A
1160	6BT5.9	160 @ 2500	N/A	29	33	37	N/A	N/A	N/A
1165	6BTA5.9	227 @ 1760	N/A	37	41	45	N/A	N/A	N/A
1165	6BTA5.9	255 @ 2100	N/A	46	50	54	N/A	N/A	N/A
1168	6BT5.9	148 @ 2300	N/A	25	28	31	N/A	N/A	N/A
1168	6BT5.9	152 @ 2500	N/A	27	31	35	N/A	N/A	N/A
1209	6BTA5.9	176 @ 2300	N/A	30	33	36	N/A	N/A	N/A
1266	6BT5.9	142 @ 2500	N/A	27	31	35	N/A	N/A	N/A
1279	6BT5.9	125 @ 2200	412 @ 1400	18	20	22	14	16	18
1322	6BTA-M1	220 @ 2500	N/A	32	36	40	N/A	N/A	N/A
1322	6BTA5.9	250 @ 2600	N/A	34	38	42	N/A	N/A	N/A
1322	6BTA-M1	250 @ 2600	N/A	42	46	50	N/A	N/A	N/A
1419	6BT5.9	250 @ 2500	N/A	38	42	46	N/A	N/A	N/A
1518	6BT5.9	169 @ 1800	N/A	32	35	39	N/A	N/A	N/A
1549	6BTA5.9	160 @ 2500	400 @ 1600	30	34	38	23	25	28
1552	6BTA5.9	210 @ 2500	485 @ 1600	44	47.7	52	29	31.9	35
1570	6BTJWA	250 @ 2600	N/A	35	39	43	N/A	N/A	N/A
1579	6BTA5.9	160 @ 2500	400 @ 1600	31	35.4	39	14	17.2	20
1613	6BT5.9	250 @ 2600	N/A	36	40	44	N/A	N/A	N/A
1640	6BTA5.9	185 @ 2200	531 @ 1500	41	45	50	27	30	33
1863	6BTAA	180 @ 2500	42 @ 1500	36	39	42	22	25	28
1889	6BTA5.9	185 @ 2400	550 @ 1500	43	46	49	30	33	36
1889	6BTA5.9	200 @ 2500	550 @ 1500	48	51	54	30	33	36
1914	6BTA5.9	190 @ 2300	475 @ 1600	44	48	52	22	26	30
1945	6BT5.9	200 @ 2200	583 @ 1500	41	46	51	31	34	37
1945	6BTA5.9	200 @ 2500	581 @ 1500	41	46	51	30	33	36
1948	6BT5.9	148 @ 2200	440 @ 1600	38	41	44	25	28	31
1948	6BT5.9	148 @ 2200	440 @ 1600	37	40	43	43	24	37
1948	6BT5.9	152 @ 2500	414 @ 1600	40	43	46	24	27	30
1948	6BT5.9	155 @ 2100	449 @ 1600	39	41.8	45	24	27	30
1959	6BTA5.9	160 @ 2500	400 @ 1600	30	34	38	18	21	24
1962	6BTA5.9	147 @ 2000	428 @ 1500	33	36	39	21	24	27
1962	6BTA5.9	150 @ 2200	466 @ 1500	35	38	41	23	26	29
1962	6BTA5.9	150 @ 2200	466 @ 1500	35	38	41	23	26	29
1962	6BTA5.9	150 @ 2200	483 @ 1500	35	38.4	41	26	28.6	32
1962	6BTA5.9	160 @ 2000	462 @ 1500	38	41	44	23	26	29
1962	6BTA5.9	166 @ 2075	474 @ 1500	42	44.6	48	25	28.1	31
1962	6BTA5.9	167 @ 2000	480 @ 1500	36	39	42	24	27	30
1962	6BTA5.9	150 @ 2200	483 @ 1500	35	38	41	26	29	32
1962	6BTA5.9	153 @ 2200	485 @ 1500	37	40	43	24	27	30
1962	6BTA5.9	165 @ 2200	512 @ 1500	42	45	48	28	31	34
1962	6BTA5.9	165 @ 2200	532 @ 1500	42	44.6	48	29	31.6	35
1962	6BTA5.9	168 @ 2200	541 @ 1500	37	40	43	24	27	30
1962	6BTA5.9	167 @ 2000	479 @ 1500	40	43	46	25	28	31
1962	6BTA5.9	170 @ 2300	475 @ 1500	42	45	48	23	26	29
1962	6BTA5.9	169 @ 2100	480 @ 1500	41	44	47	25	28	31
1962	6BTA5.9	169 @ 2100	480 @ 1500	41	44	47	25	28	31
1968	6BTAA	160 @ 2500	400 @ 1600	30	34	38	19	22	25
1975	6BTA5.9	330 @ 2800	687 @ 2000	52	57	62	37	41	45
1989	6BTA5.9	185 @ 2500	553 @ 1500	47	51	55	33	37	41
2016	6BTAA5.9	129 @ 2500	347 @ 1500	25	29.2	33	11	13.9	17
2017	6BTA5.9	178 @ 2500	474 @ 1500	34	36.6	40	19	21.6	25
2023	6BTAA	21 @ 2600	440 @ 1600	48	51	54	23	26	29
2035	6BTA5.9	195 @ 2800	420 @ 1600	32	35	38	25	28.5	31
2063	6BTA5.9	185 @ 2300	580 @ 1500	40	43	46	33	36	39
2063	6BTA5.9	185 @ 2400	558 @ 1500	46	48.7	52	30	33.1	36

(Continued)

CPL	MODEL EN-GINE	hp @ rpm RATING	PEAK TORQUE ft-lb @ rpm	RATED BOOST (in Hg)			PEAK TORQUE BOOST (in Hg)		
				min	nom	max	min	nom	max
2063	6BTA5.9	185 @ 2200	566 @ 1500	40	43	46	33	36	39
2063	6BTA5.9	174 @ 2200	590 @ 1500	45	48	51	36	39	42
2071	6BT5.9	97 @ 2200	267 @ 1700	21	24	27	13	16	19
2071	6BT5.9	97 @ 2200	270 @ 1700	20	24	28	12	16	20
2071	6BT5.9	101 @ 2200	313 @ 1500	23	26	29	11	14	17
2071	6BT5.9	118 @ 2400	327 @ 1600	35	38	41	16	19	22
2071	6BT5.9	110 @ 1900	341 @ 1600	27	30	33	17	20	23
2071	6BT5.9	110 @ 2200	341 @ 1600	28	31	34	18	21	24
2071	6BT5.9	120 @ 2200	372 @ 1500	32	35	38	22	25	28
2071	6BT5.9	126 @ 2100	380 @ 1600	29	32	35	19	22	25
2071	6BT5.9	130 @ 2200	388 @ 1600	33	36	39	20	23	26
2071	6BT5.9	130 @ 2500	368 @ 1600	42	44.9	48	18	21	24
2071	6BT5.9	135 @ 2100	404 @ 1600	30	33	36	19	22	25
2071	6BT5.9	135 @ 2200	419 @ 1500	32	35	38	19	22	25
2071	6BT5.9	135 @ 2200	419 @ 1600	35	38	41	23	26	29
2071	6BT5.9	135 @ 2400	379 @ 1600	42	45	48	21	24	27
2071	6BT5.9	135 @ 2200	419 @ 1600	37	40	43	25	28	31
2071	6BT5.9	135 @ 2100	419 @ 1500	30	33	36	19	22	25
2071	6BT5.9	140 @ 2000	416 @ 1600	32	35	38	23	26	29
2071	6BT5.9	145 @ 2100	438 @ 1500	38.4	41.4	44.4	40	42.1	44
2071	6BT5.9	137 @ 2000	440 @ 1600	32	35.1	38	28	31	34
2072	6BTA5.9	174 @ 2500	458 @ 1500	43	46.1	49	24	27.2	30
2072	6BTA5.9	174 @ 2500	470 @ 1500	42	45	48	24	27	30
2174	6BTAA5.9	180 @ 2500	420 @ 1500	36	39	42	22	25	28
2175	6BTAA5.9	215 @ 2600	440 @ 1600	48	51	54	23	26	29
2122	6BTA5.9	177 @ 2500	480 @ 1500	N/A	N/A	N/A	N/A	N/A	N/A
2208	6BTA	370 @ 3000	726 @ 2200	56	59	62	40	43	46
2249	6BTAA5.9	232 @ 2500	590 @ 1500	50	52.6	56	30	32.5	36
2292	6BTA5.9	147 @ 2000	438 @ 1500	35	38	41	23	26	29
2292	6BTA5.9	160 @ 1900	479 @ 1500	38	41	44	23	26	29
2292	6BTA5.9	169 @ 2100	480 @ 1500	41	44	47	25	28	31
2292	6BTA5.9	169 @ 2100	485 @ 1500	41	44	47	23	26	29
2292	6BTA5.9	169 @ 2100	485 @ 1500	45	47.5	51	29	31.6	35
2292	6BTA5.9	167 @ 2000	480 @ 1500	37	39.6	43	25	27.5	31
2308	6BTAA5.9	180 @ 2500	420 @ 1500	36	39	42	22	25	28
2479	6BTA5.9	174 @ 2200	590 @ 1500	46	48.4	51	37	39.9	43
2530	6BT5.9	135 @ 1800	N/A	30	32.5	35	N/A	N/A	N/A
2530	6BT5.9	143 @ 1800	N/A	29	31.9	35	N/A	N/A	N/A
2530	6BT5.9	170 @ 1800	N/A	20	21.8	23	N/A	N/A	N/A

## Air Intake System - General Information

The engine was designed as a turbocharged engine, but a naturally aspirated version of the B engine is available for industrial applications.

Air is pulled into the engine from an air filter. Clean air is very important to the life of the engine. Ingested dust and dirt can very quickly damage the cylinders.

**Make sure that an excellent-quality air cleaner is used and that it is periodically replaced according to the manufacturer's recommendations.**

Intake air for the naturally aspirated engine flows from the air cleaner to the intake manifold. From the intake manifold, the air is pulled into the cylinders and used for combustion. After combustion it is forced out of the cylinders and through the exhaust manifold.

On the turbocharged engines the intake air is drawn through the air cleaner, into the compressor side of the turbocharger, and then through the crossover tube and into the intake manifold. From the intake manifold, the air is forced into the cylinders and used for combustion. Energy from the exhaust gases is utilized by flowing the exhaust through the exhaust side of the turbocharger to drive the turbine wheel. The turbine wheel and shaft drive the compressor wheel, which forces more air into the cylinders for combustion. The additional air provided by the turbocharger allows more fuel to be injected to increase the power output from the engine.

On turbocharged—aftercooled engines, intake air from the turbocharger flows through the cooling fins of the aftercooler before entering the intake manifold. The cooled air becomes more dense and contains more oxygen, which allows more fuel to be injected, further increasing the power output from the engine.

The 1991 to 1994 automotive engines use a chassis-mounted charge air cooler instead of an engine-mounted aftercooler to provide cooler charge air to the engine to improve engine performance and reduce emissions. This system also uses large-diameter piping to transfer the air from the engine turbocharger to the charge air cooler; then returns the air from the charge air cooler to the engine intake manifold.

**NOTE:** The long-term integrity of the charge air cooling system is the responsibility of the vehicle and component manufacturers.

Some turbocharged engines use a wastegated turbocharger to limit the maximum boost pressure that the turbocharger can develop. Wastegate operation is controlled by an actuator that senses compressor pressure and balances it against a preset spring-load. The wastegate valve is located in the turbine inlet passage. When open, it diverts a portion of the exhaust gas away from the turbine wheel, thereby controlling the shaft speed and boost. This also allows for better boost at lower speeds.

### **▲ CAUTION ▲**

**Do not tamper with the turbocharger because it is a performance part. The wastegate bracket is an integral part of the turbocharger. Tampering with the wastegate components can reduce durability by increasing cylinder pressure and thermal loading due to incorrect inlet and exhaust manifold pressure. Poor fuel economy and failure to meet regulatory emission laws can result. Increasing the turbocharger boost will not increase engine power.**

The turbine and compressor wheels and shaft are supported by two rotating bearings in the bearing housing. Passages within the bearing housing direct filtered, pressurized engine oil to the shaft bearings and thrust bearing. The oil is used to lubricate and cool the rotating components to provide for smooth operation. The oil then drains from the bearing housing to the engine sump through the oil drain line. A restricted or damaged oil drain line can cause the turbocharger bearing housing to be pressurized, causing oil to leak past the seals.

**NOTE:** An adequate supply of good, filtered oil is very important to the life of the turbocharger. Make sure that an excellent-quality oil is used and that it and the oil filter are changed according to the maintenance recommendations.

### **▲ CAUTION ▲**

**A catalyst is installed on all EPA- and CARB-approved automotive applications. Lubricating oil blending is not permitted. It will plug up and eventually damage the catalyst. High-sulfur fuels must not be used with the catalyst. No welding or modifications of the catalyst are permitted without permission of the catalyst manufacturer.**

### Aftercooler (010-001)

#### Preparatory (010-001-000)



**WARNING**

Coolant is toxic. If not reused, dispose of in accordance with local environmental regulations

- Disconnect the cold starting aid ( if equipped). Refer to Procedure 010-029.
- Remove the air crossover tube. Refer to Procedure 010-019.
- Drain 2 liters [2.1 qt] of coolant. Refer to Procedure 008-018.

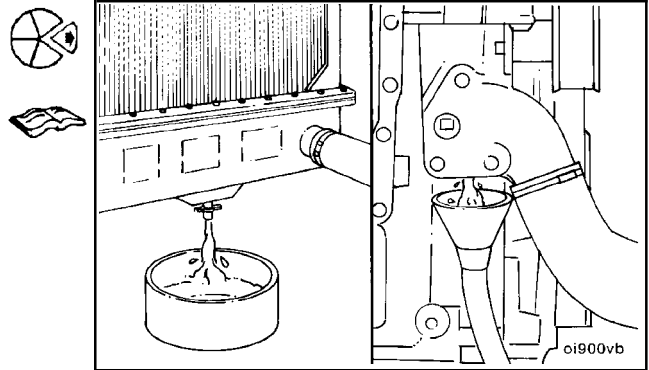

#### Remove (010-001-002)

8 mm

Remove the coolant supply tube (1) and the coolant return tube (2).

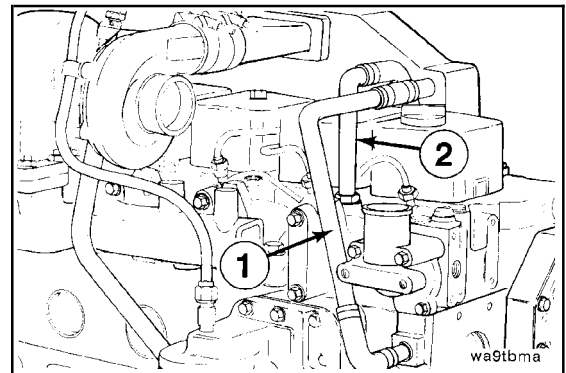

10 mm

Remove the aftercooler housing and gasket.

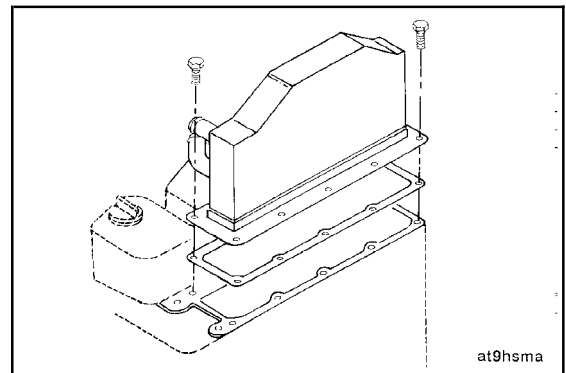

#### Clean (010-001-006)

Clean the sealing surface.

**NOTE:** Keep the gasket material and any other material out of the air intake.

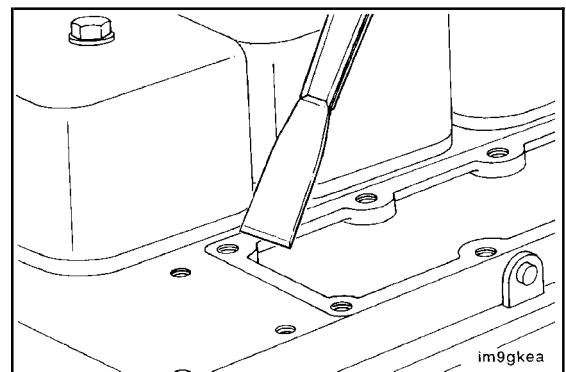

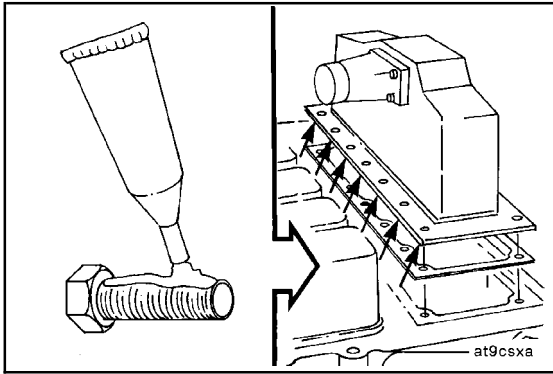

**Install (010-001-026)**

10 mm



**NOTE:** The holes shown in the illustration are drilled through. Apply liquid teflon sealant to the capscrews.

Install the aftercooler housing and a new gasket.



**Torque Value:** 24 N•m [18 ft-lb]

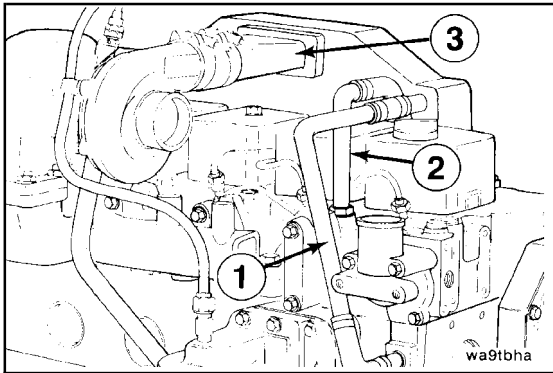

8 mm

Install the coolant supply tube (1) and coolant return tube (2). Install the air crossover tube (3).



**Torque Value:** 8 N•m [71 in-lb]

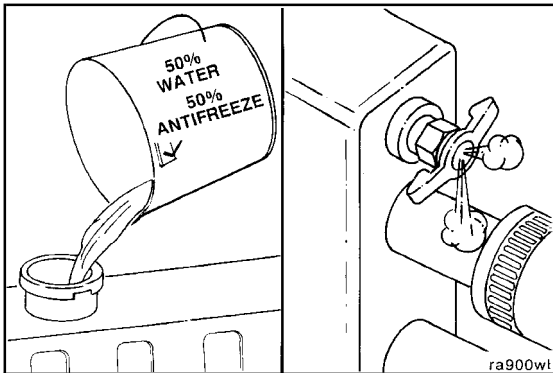

**Fill (010-001-028)**



**During filling, air must be vented from the engine cooling passages. Open the engine vent petcock. Make sure to open the petcock on the aftercooler, for aftercooled engines. The system must be filled slowly to prevent air locks. Wait 2 to 3 minutes to allow air to be vented, then add coolant to bring the level to the bottom of the radiator filler neck. Failure to do so will cause entrapment of air in cooling system and will cause engine to overheat.**

Fill the coolant system with a premixture of 50-percent water and 50-percent ethylene-glycol-type antifreeze.

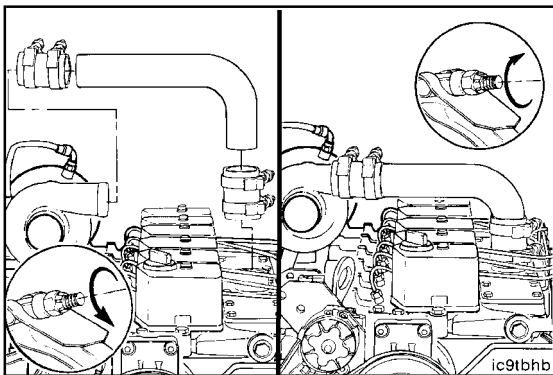

**Air Crossover (010-019)**

**Remove (010-019-002)**

8 mm or Screwdriver



Loosen the hose clamps, and position the hose so the crossover tube can be removed.

**Inspect for Reuse (010-019-007)**

Check the crossover tube for cracks, holes, and worn sections.

Replace with a new hose and clamps, if necessary.

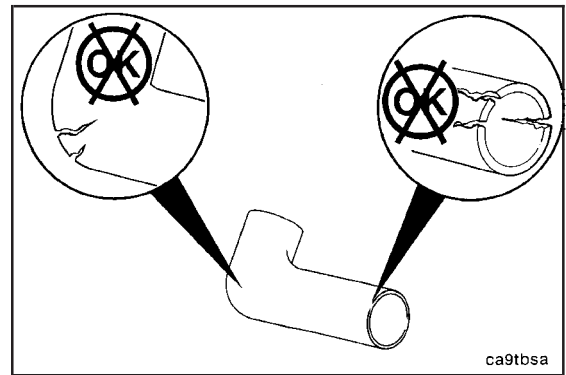

Operate engine, and check for leaks.

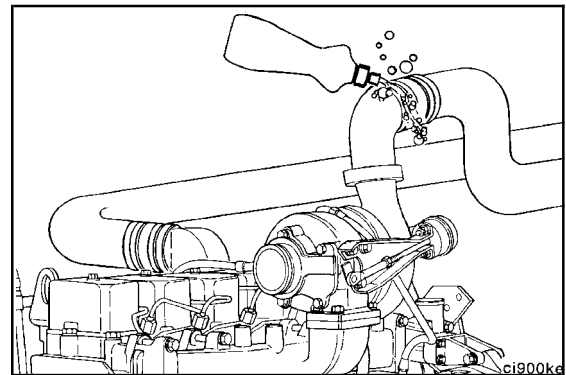

**Install (010-019-026)**

**8 mm or Screwdriver**

Install the crossover tube and clamps in the reverse order of removal.

Tighten the clamps.

**Torque Value:** 8 N•m [71 in-lb]

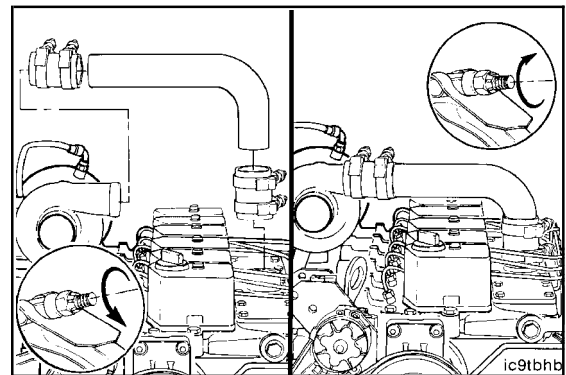

**Air Intake Manifold (010-023)**

**Preparatory (010-023-000)**

- Disconnect the cold starting aid (if equipped). Refer to Procedure 010-072.
- Remove the air crossover tube (if equipped). Refer to Procedure 010-019.
- Disconnect the charged air cooler hose (if equipped). Refer to Procedure 010-027.
- Remove the high-pressure fuel lines. Refer to Procedure 006-051.
- Remove air intake piping. Refer to Procedure 010-022.

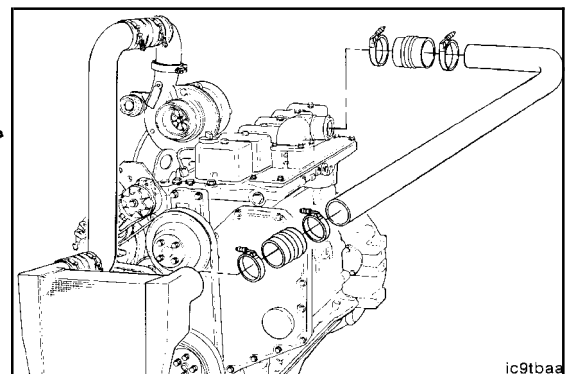

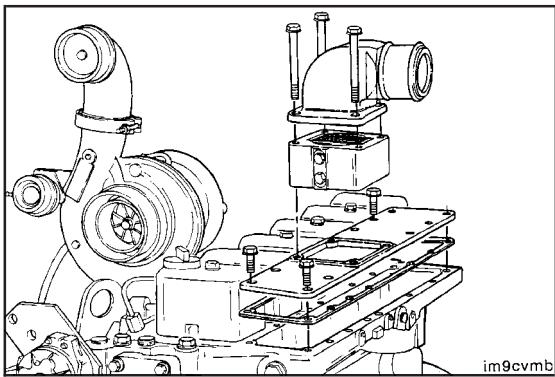

**Remove (010-023-002)**

10 mm



Remove the manifold cover, gasket, and grid heater (if equipped).

Remove the manifold cover and gasket.

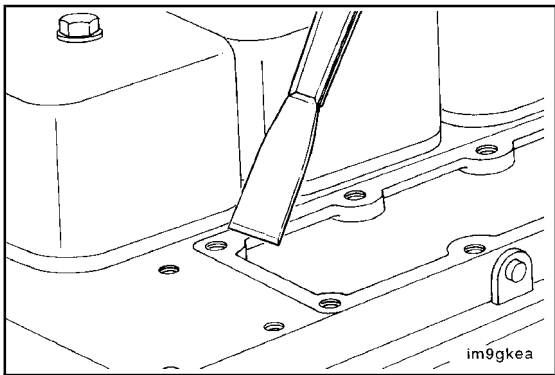

**Clean (010-023-006)**

Clean the sealing surface.

**NOTE:** Keep the gasket material and any other material out of the air intake.

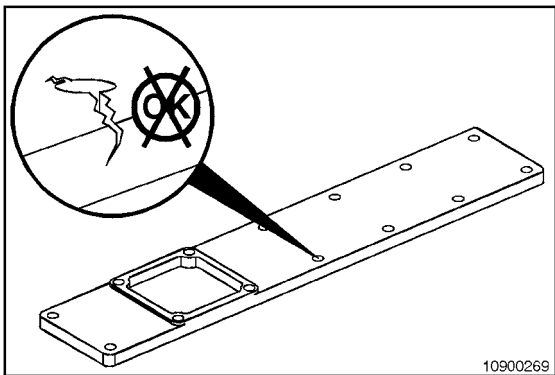

**Inspect for Reuse (010-023-007)**

Check the air intake manifold for cracks and holes.

Replace the air intake manifold, if necessary.

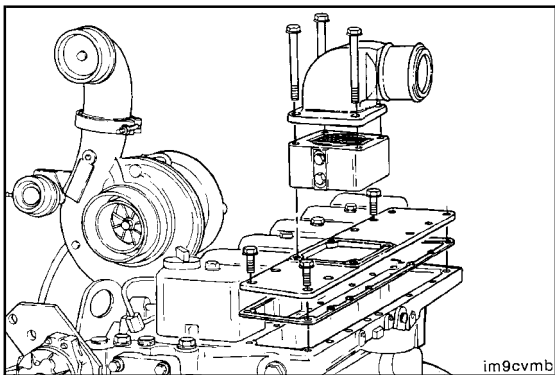

**Install (010-023-026)**

10 mm



Install the cover and a new gasket.

**Torque Value:** 24 N•m [18 ft-lb]

Connect charged air cooler hose.





Assemble the intake piping, and connect the cold starting aid (if equipped).

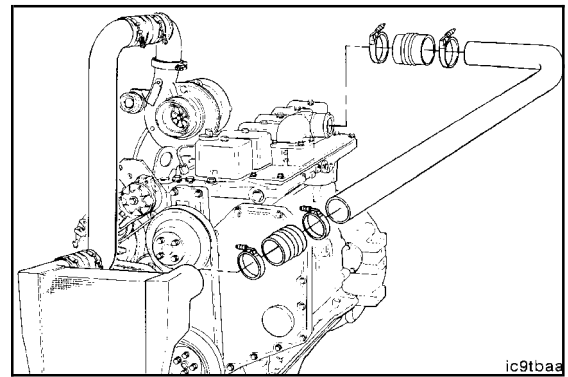

ic9tbaa

### Air Leaks, Air Intake and Exhaust Systems (010-024)

#### Initial Check (010-024-001)



Engine intake air must be filtered to prevent dirt and debris from entering the engine. If intake air piping is damaged or loose, unfiltered air will enter the engine and cause premature wear.

Inspect the intake air piping for cracked hoses, damage, or loose clamps.

Replace damaged pipes, and tighten loose clamps, as necessary, to make sure the air intake system does **not** leak.

**Torque Value:** 8 N•m [71 in-lb]

Check for corrosion of the intake system piping under the clamps and hoses. Corrosion can allow corrosive products and dirt to enter the intake system. Disassemble and clean, as required.

Operate the engine at high idle, and use a solution of soapy water to spot intake air leaks.

If an air leak exists, the soap bubbles will be drawn in with the air.

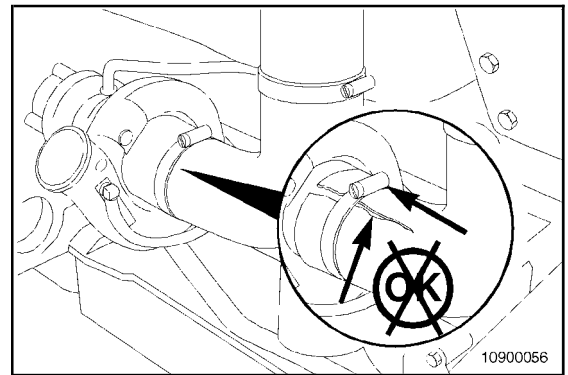

10900056

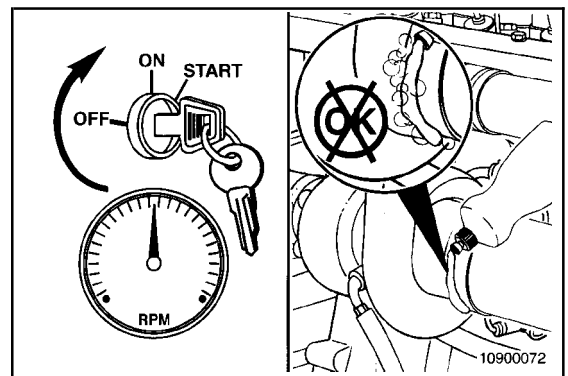

10900072

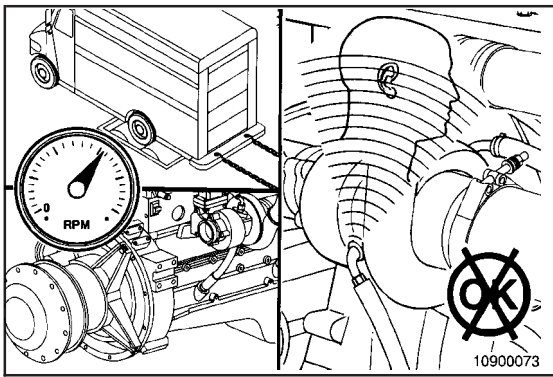

Operate the engine at full throttle and rated rpm with maximum load.

Listen for a high-pitched whistling noise from the turbocharger, nearby piping, and connections.

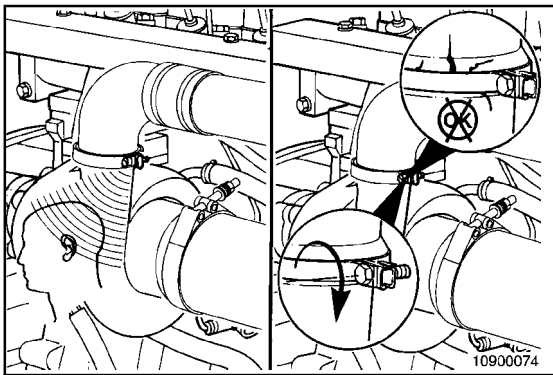

The noise can be caused by an air leak from the:

1. Turbocharger-to-discharge elbow connection.
  - Inspect for damage. Tighten loose clamps.



**Torque Value:** 8 N•m [71 in-lb]

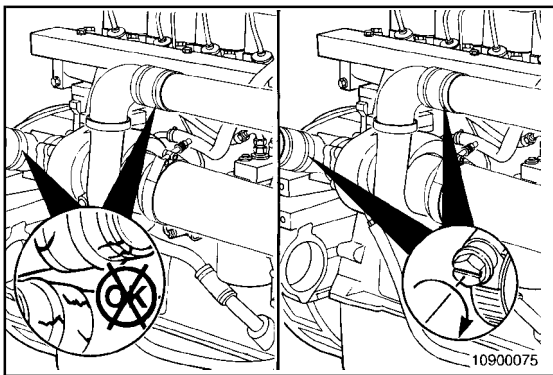

2. Any charge air cooler tubing or connecting hoses.
  - Inspect the hose and tubing for damage.
  - Tighten the hose clamps.
  - Refer to the manufacturer's specifications for the correct torque value.

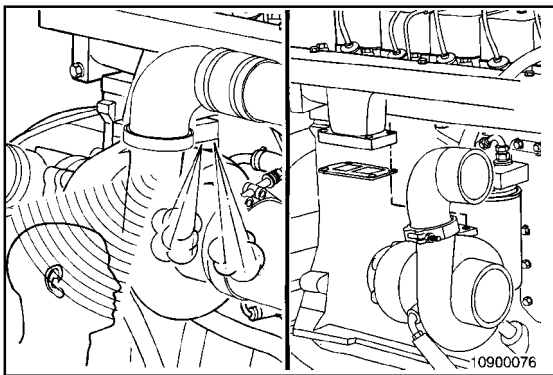

3. Turbocharger-to-exhaust-manifold mounting gasket.
  - Replace the gasket. Refer to Procedure 010-033.



Operate the engine at full throttle and rated rpm with maximum load.

Listen again for leaks.

Replace the turbocharger if the air piping is **not** damaged and the noise can still be heard. Refer to Procedure 010-033.

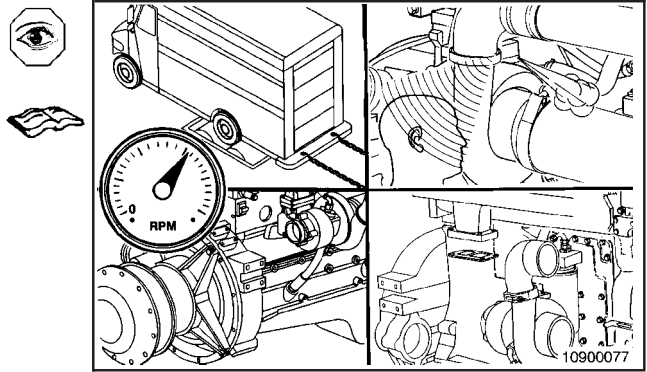

**Damage from Nonfiltered Air**

Loose connections or cracks in the suction side of the intake pipe and after the air filter can allow debris to be ingested by the engine, causing rapid wear in the cylinders.

Leaks at the intake manifold, unsealed bolt holes, or manifold cover gasket can also allow dust and dirt to be ingested into naturally aspirated engines.

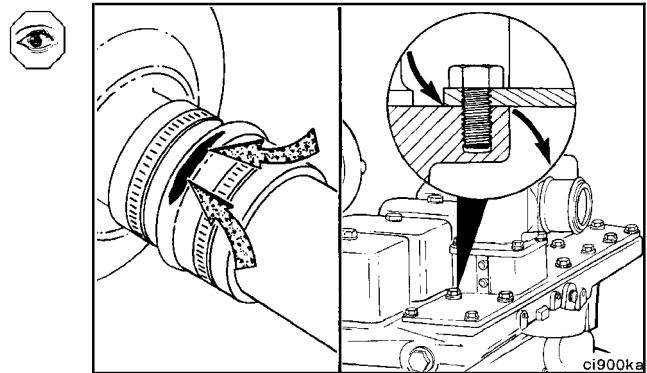

Debris drawn into the air suction side can damage the compressor blades, causing an imbalance resulting in bearing failure.

To verify a bearing failure or damaged compressor, remove the intake and exhaust piping, and check for contact. The rotor assembly **must** rotate freely and should **not** be damaged. Measurement of axial and radial clearance is described in this section.

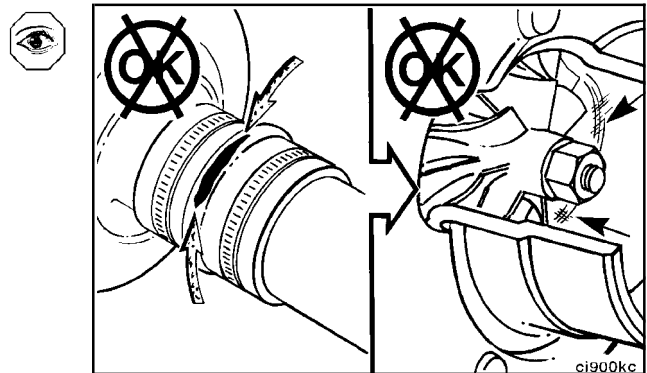

**Turbocharger Engines — Air Leaks, Pressure Side**

Excessive smoke and low power from a turbocharged engine can be caused by pressurized air leaking from loose connections or cracks in the crossover tube or intake manifold. This can also cause a noise problem.

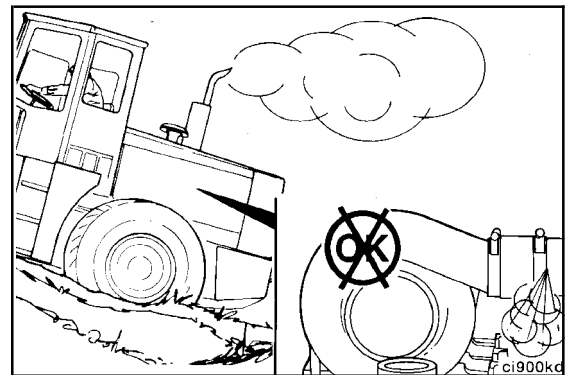

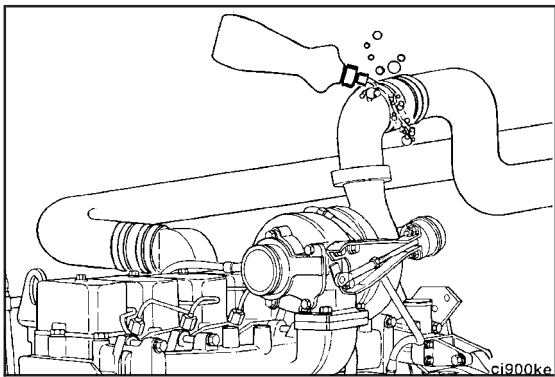

In addition to the inspection for cracks and loose fittings, liquid soap can be applied to the charge air cooler, connections, and the manifold cover sealing surfaces to find the leaks. The leaks will create bubbles that are easier to detect. Measurement of manifold pressure is described in this section.

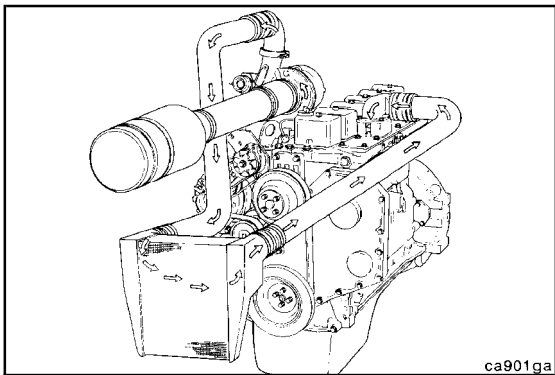

### Charge-Air Cooler (CAC) (010-027)

#### General Information

**NOTE:** The long-term integrity of the charge air cooler system is the responsibility of the vehicle and component manufacturers; however, the following can be checked by any Cummins Authorized Repair Location.

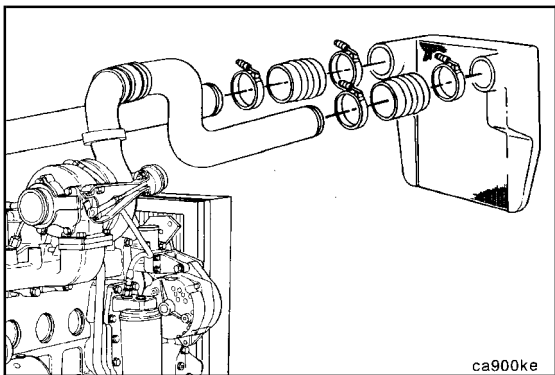

#### Clean (010-027-006)

If the engine experiences a turbocharger failure or any other occasion where oil or debris is put into the CAC, the CAC **must** be cleaned.



Remove the CAC from the vehicle. Refer to the vehicle manufacturer's instructions.

**▲ WARNING ▲**

When using solvents, acids, or alkaline materials for cleaning, follow the manufacturer's recommendations for use. Wear goggles and protective clothing to avoid personal injury.

**▲ WARNING ▲**

Wear appropriate eye and face protection when using compressed air. Flying debris and dirt can cause bodily injury.

**▲ CAUTION ▲**

If internal debris can not be removed, scrap the CAC.

**▲ CAUTION ▲**

Do not use caustic cleaners to clean the CAC. Damage to the CAC can result.

Flush the CAC internally with solvent in the opposite direction of normal airflow. Shake the CAC, and lightly tap on the end tanks with a rubber mallet to dislodge trapped debris. Continue flushing until all debris or oil is removed.

Use a flashlight and mirror to inspect the CAC for internal debris.

**▲ WARNING ▲**

Wear appropriate eye and face protection when using compressed air. Flying debris and dirt can cause bodily injury.

**▲ CAUTION ▲**

The charge air cooler (CAC) must be rinsed and dried, and free of solvent, oil, and debris or engine damage will result.

After the CAC has been thoroughly cleaned of all oil and debris with solvent, wash the CAC internally with hot, soapy water to remove the remaining solvent. Rinse thoroughly with clean water.

Blow compressed air into the CAC in the opposite direction of normal airflow until the CAC is dry internally.

**Inspect for Reuse (010-027-007)**

If the engine experiences a turbocharger failure or any other occasion where oil or debris is put into the charge air cooler, the charge air cooler **must** be cleaned.

Remove the charge air cooler from the vehicle. Refer to the vehicle manufacturer's instructions.

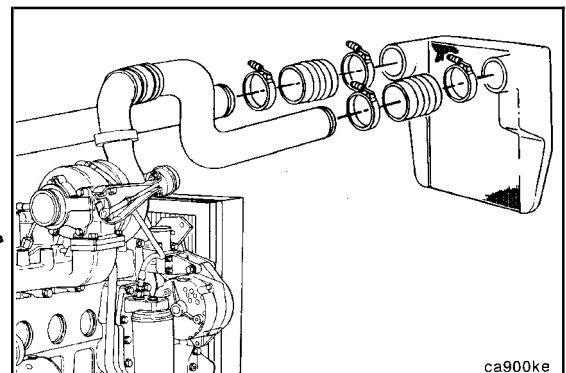
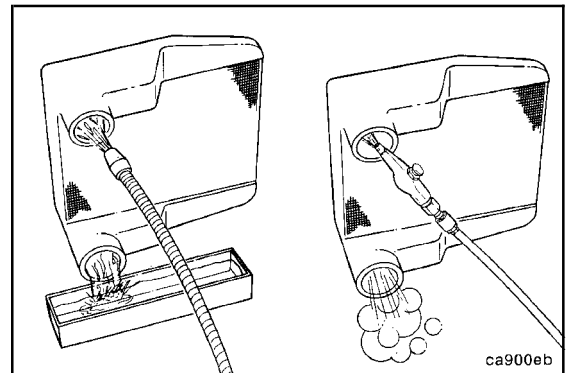
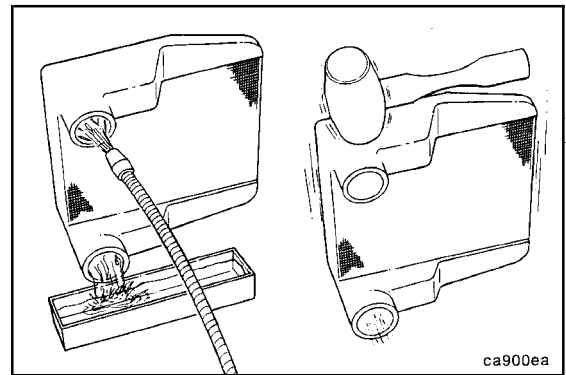

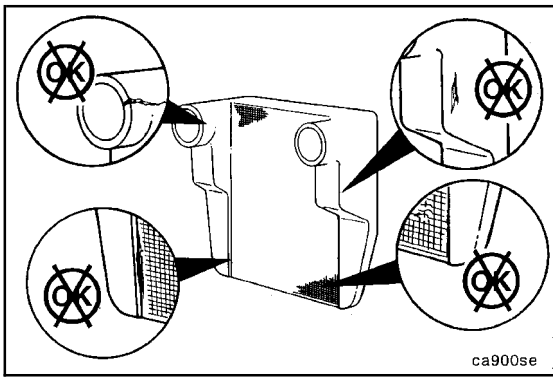

Inspect the charge air cooler for cracks, holes, or damage.

Inspect the tubes, fins, and welds for tears, breaks, or other damage.



Refer to Section A for the leak check procedure.

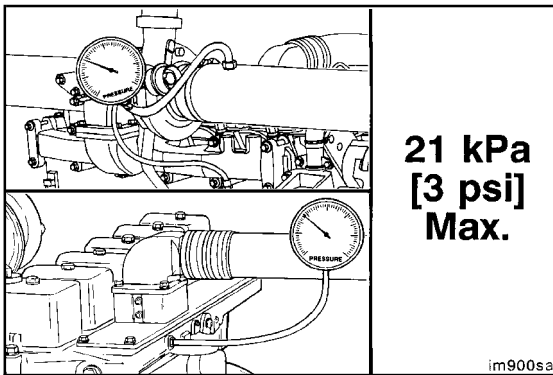

**Pressure Test (010-027-013)**

**Pressure Gauge, Part No. ST-1273**



Install pressure gauge, Part No. ST-1273, to the fitting in the turbocharger outlet.

Install another pressure gauge, Part No. ST-1273, in the intake manifold.



Operate the engine at rated rpm and load. Record the readings on the two gauges.

If the differential pressure is greater than 21 kPa [3 psi], check the charge air cooler for plugging. Clean or replace if necessary.

**Differential Pressure:** 21 kPa [3 psi]

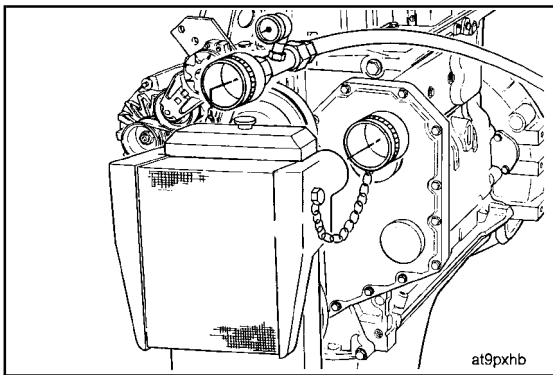

**Leak Test (010-027-014)**



**WARNING**



To avoid possible injury from either plug blowing off during the test, secure the safety chains on the test plugs to any convenient capscrew on the radiator assembly. This test must be performed with securely fastened safety chains.

**Charge-Air-Cooler (CAC) Test Kit, Part No. 3824556**

Install a cap over the outlet side of the charge air cooler (CAC). Install a pressure gauge, air supply, and air pressure regulator to the inlet side of the cooler.

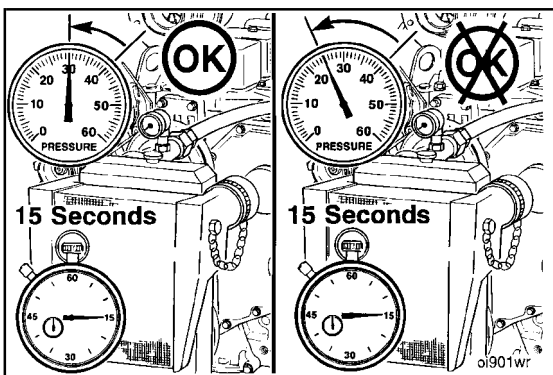

Apply 207 kPa [30 psi] of air pressure to the charge air cooler (CAC). Close the air pressure regulator.

Monitor the pressure gauge and determine the rate of pressure decay with a stopwatch.

If the pressure decay is 49 kPa [7 psi] or less in 15 seconds, the cooler is okay. If the pressure drop is greater than 49 kPa [7 psi] in 15 seconds, check all connections again.

Determine if the pressure decay is caused by a leak in the charge air cooler (CAC) or from a leaky connection. Use a spray bottle filled with soapy water applied to all hose connections, and watch for bubbles to appear at the location of the leak.

If the pressure decay is caused by a leaky connection, repair the connection and repeat the test. If the leak is within the CAC, repeat the test to verify the accuracy of the pressure decay measurement. Similar pressure decay readings **must** be obtained at least three consecutive tests before the reading can be considered accurate.

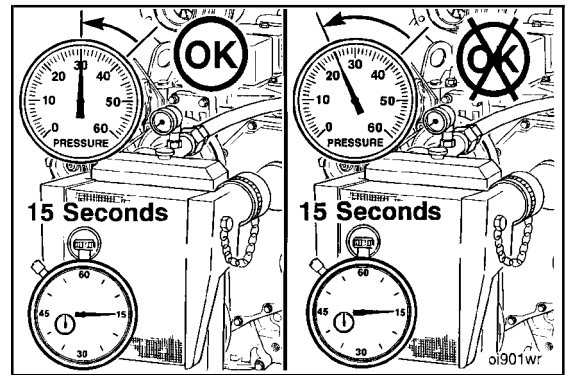

If the pressure drop is greater than 49 kPa [7 psi] in 15 seconds, the CAC **must** be replaced.

Refer to the OEM service manual for replacement instructions.

**NOTE:** Charge air coolers (CAC) are **not** designed to be 100-percent leak-free. If the pressure decay is less than 49 kPa [7 psi] in 15 seconds, then the CAC does **not** need to be replaced.

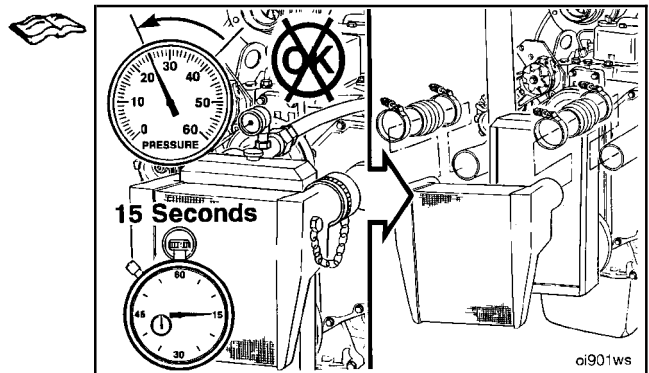

**⚠ CAUTION ⚠**

Debris trapped in the charge air cooler, if not cleaned, will cause internal engine damage.

The charge air cooler **must** be cleaned following any turbo-charger or air cleaner malfunction.

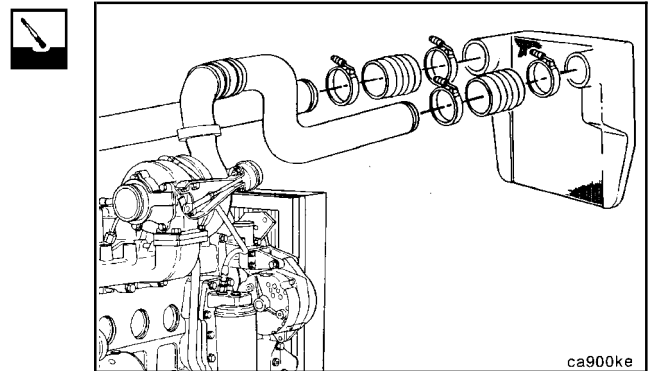

**Temperature Differential Test (010-027-049)**

Inspect the charge air cooler (CAC) fins for obstructions to airflow. Remove obstructions such as a winterfront or debris. Manually lock shutters in the open position, if equipped.

Lock the fan drive in the ON mode to prevent erratic test results. This can be done by installing a jumper wire across the temperature switch.

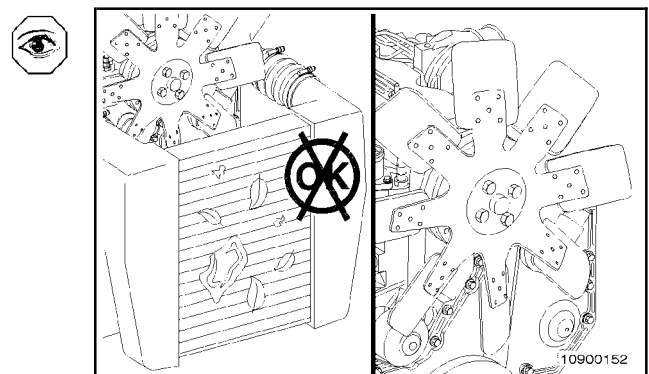

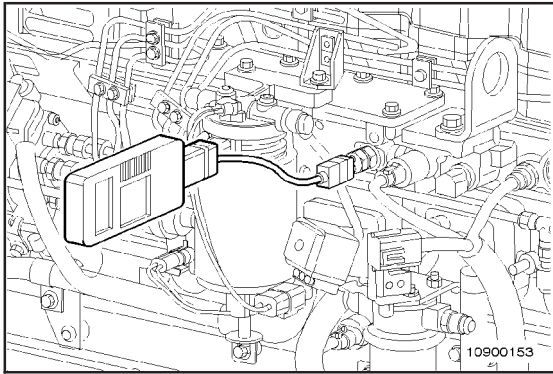

**Fluke Digital Thermometer, Part No. 3822666**

Install fluke digital thermometer, Part No. 3822666, and thermocouple wire kit, Part No. 3822988, into the intake manifold at the 1/8-inch NPT tap near the air horn connection with the intake manifold.



Another alternative would be to use the monitor mode on the INSITE™ service tool.

Install another thermocouple at the air cleaner inlet to measure ambient air temperature.

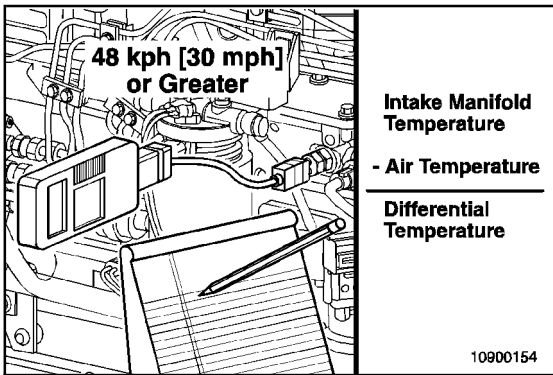

Perform a road test with the engine at peak power and a vehicle speed of 48 kph [30 mph] or greater.

Record the intake manifold temperature and the ambient air temperature.

Calculate the differential temperature:

Intake manifold temperature - ambient air temperature = differential temperature.

Maximum differential temperature = 28°C [82°F].

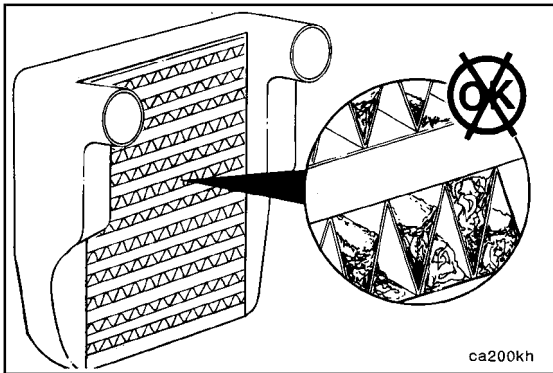

If the temperature differential is greater than the specifications, check the charge air cooler (CAC) for dirt and debris on the fins and clean as necessary. If the problem still exists, check the charge air cooler (CAC) for debris in the fins or between the charge air cooler (CAC) and radiator. Confirm full-fan engagement.

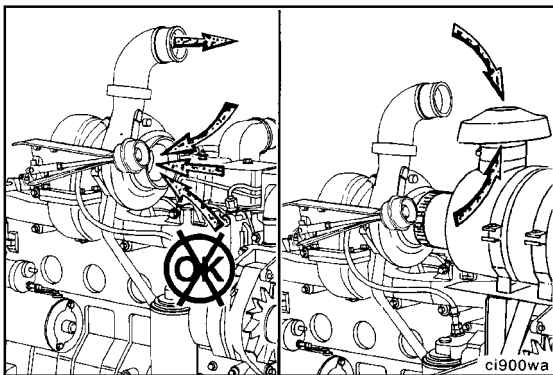

**Air Intake Restriction (010-031)**

**General Information**

**Diagnosing Air System Malfunctions**

The correct amount of clean air to the cylinders is required for good performance. As discussed earlier in Airflow System, ingested dust and dirt will damage the engine cylinders. Dust and dirt can also damage the valve stems and guides, as well as wear down the turbocharger compressor vanes affecting efficiency. Larger debris can damage the blades of the turbocharger.



**Airflow restriction results in excessive smoke and low power.**

Restriction increases as the filter removes contaminants from the intake air. Restriction airflow changes the air-to-fuel ratio, reducing power and increasing smoke from the engine. Verify that the air cleaner is being maintained correctly.

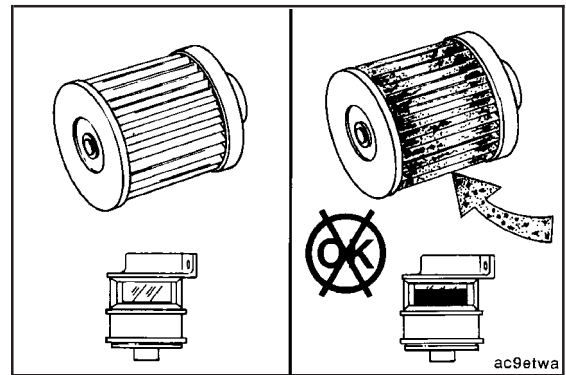

**Intake Air Restriction — Checking**

Replace the air cleaner element when the restriction reaches the maximum limit at rated engine power and speed.

Naturally Aspirated	Turbocharged
50.8 mm H <sub>2</sub> O [2 in. H <sub>2</sub> O]	63.5 mm H <sub>2</sub> O [2.5 in. H <sub>2</sub> O]

**NOTE:** The illustration shows the measurement in centimeters instead of millimeters.

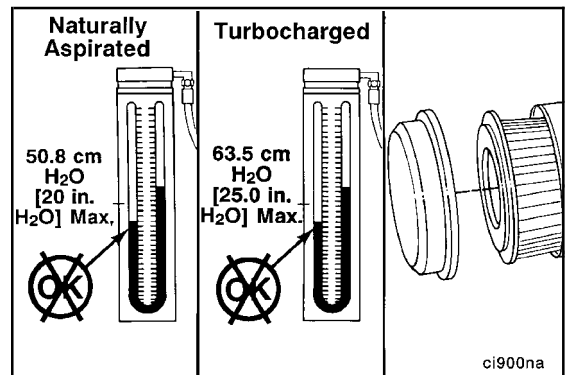

For turbocharged engines, measure the restriction just before the turbocharger. Measure just before the intake manifold for naturally aspirated engines.

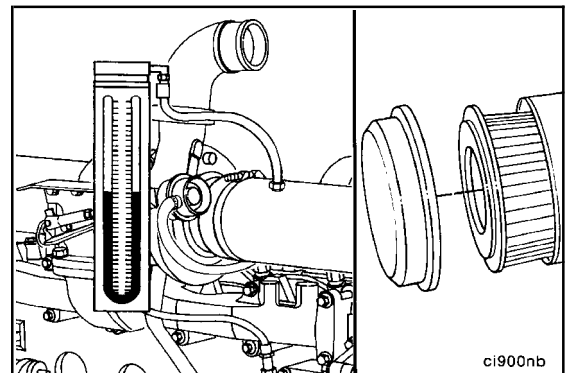

**Measure (010-031-010)**

**Manometer, Part No. ST-1111-3**

Install a vacuum gauge or water manometer, Part No. ST-1111-3, in the intake air piping.

The gauge adapter **must** be installed at a 90-degree angle to the airflow in a straight section of pipe, one pipe diameter before the turbocharger.

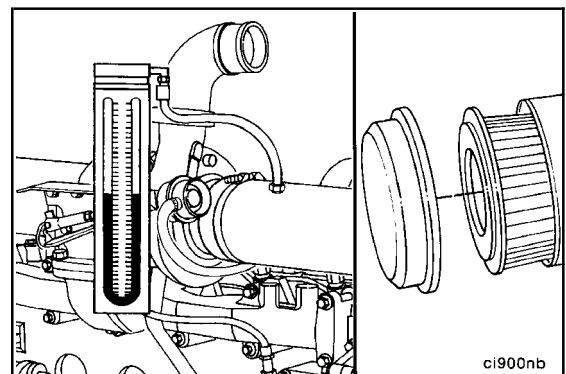

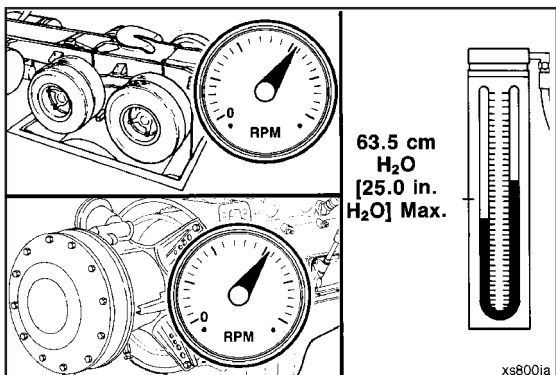

Operate the engine at full throttle and rated rpm with maximum load.

Record the data on the gauge or manometer.

	Inlet Air Restriction	
	mm H <sub>2</sub> O	in H <sub>2</sub> O
Turbocharged	63.5	MAX
Naturally Aspirated	50.8	MAX
		2

**NOTE:** The illustration shows the measurement in centimeters instead of millimeters.

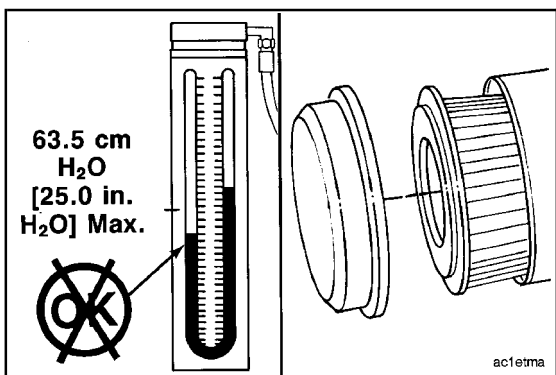

If restriction exceeds specifications:

Replace or clean the air filter element. Refer to the equipment manufacturer's instructions.

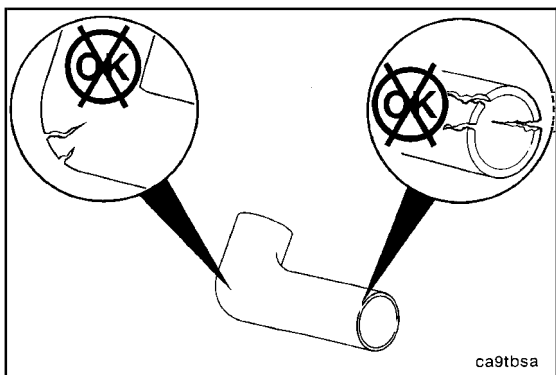

Inspect the intake piping for damage. Refer to the equipment manufacturer's repair instructions.

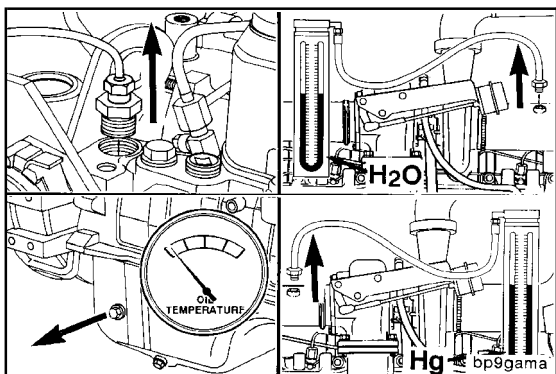

Remove the test equipment.

## Turbocharger (010-033)

### General Information

#### Turbocharged Engines — Exhaust Leaks

Inspect for exhaust leaks at the exhaust manifold, exhaust pipe, and turbocharger gasket. Check for muffler or catalyst restrictions. Leaks or restrictions will cause the turbine and impeller to operate at a lower speed and reduce the amount of air being forced into the cylinders. Again, the symptom will be excessive smoke, low-manifold pressure, and low power.

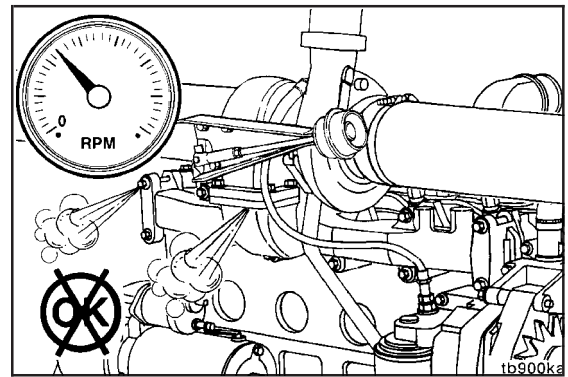

#### Lubricating Oil Consumption and Leaks

Engine lubricating oil is used to lubricate the bearings and provide some cooling for the turbocharger. The lubricating oil supplied to the turbocharger through the supply line is at engine operating pressure. A return line connected to the bottom of the turbocharger routes the lubricating oil back to the engine lubricating oil pan.

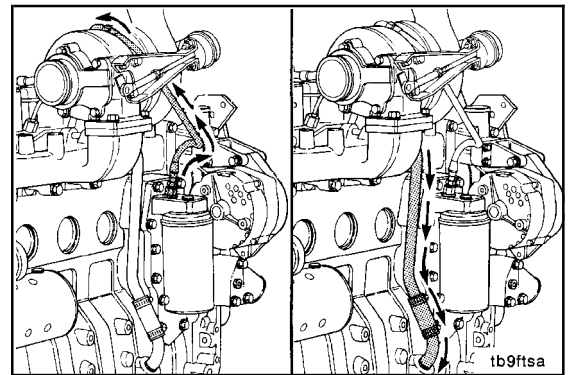

Seal rings are used on each end of the rotor assembly. The primary function of the seals is to prevent exhaust gases and compressed air from entering the turbocharger housing. Lubricating oil leakage from the seals is rare, but it can occur.

**NOTE:** Excessive crankcase pressure will **not** allow the oil to drain from the turbocharger. This will load the bearing housing and allow lubricating oil to leak past the compressor seals and into the engine.

If turbine seal leakage into the exhaust occurs on engines with a catalyst, check the exhaust restriction during the repair.

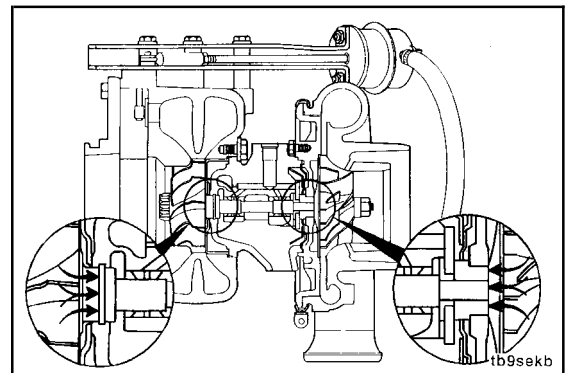

A restricted or damaged lubricating oil return line will cause the turbocharger housing to be pressurized, causing lubricating oil to migrate past the seals.

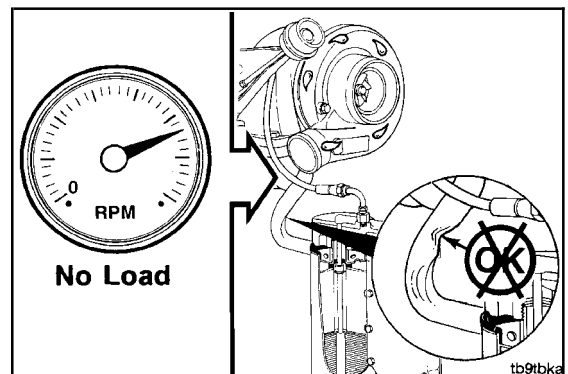

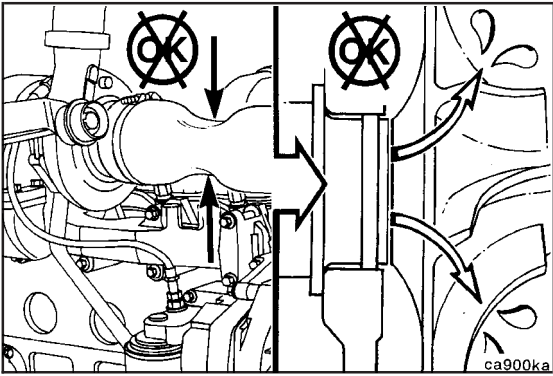

Additionally, high intake or exhaust restrictions can cause a vacuum between the compressor and the turbocharger housing, resulting in oil leaking past the seals.

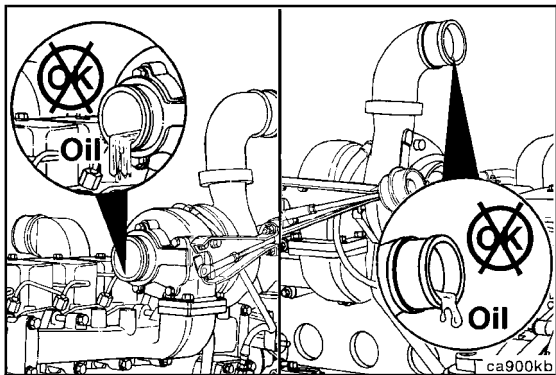

To verify lubricating oil leakage past the seals, remove the exhaust pipe and crossover tube, and check for lubricating oil in the turbine casing and the crossover tube. Locate and correct the restriction as previously discussed.

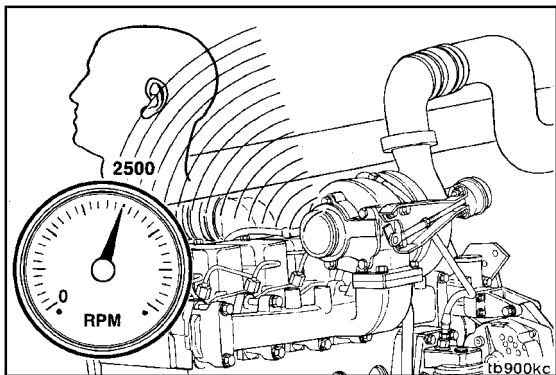

**Turbocharger Noise**

It is normal for the turbocharger to emit a “whining” sound that varies in intensity depending on engine speed and load. The sound is caused by the very high rotational speed of the rotor assembly. Consequently, the sound will become more audible at full speed.

**If possible, operate the engine at full speed to verify the noise level.**

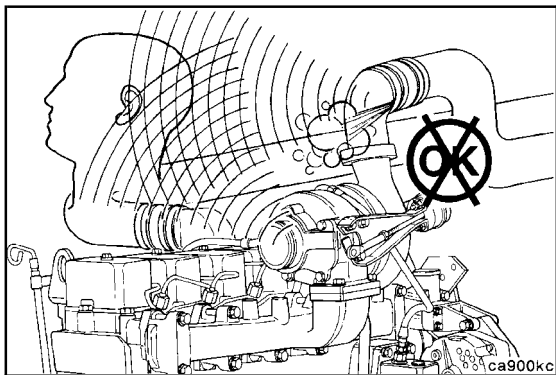

Leaks in the air system intake and/or exhaust components can produce additional noises.

Pressurize the intake system, and check for air intake and crossover tube leaks.

Before removing the turbocharger, make sure the noise complaint is not caused by leaks in the air system components.



Check for loose turbocharger mounting, exhaust manifold gasket leaks, and cracks in the exhaust manifold.

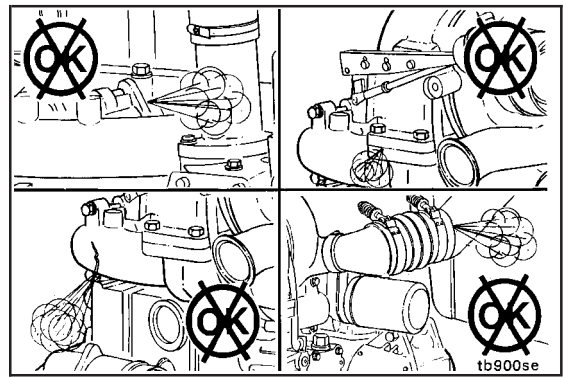

Lower pitched sounds or rattles at slower engine speeds can indicate that debris in the system or the rotor assembly is touching the housings.

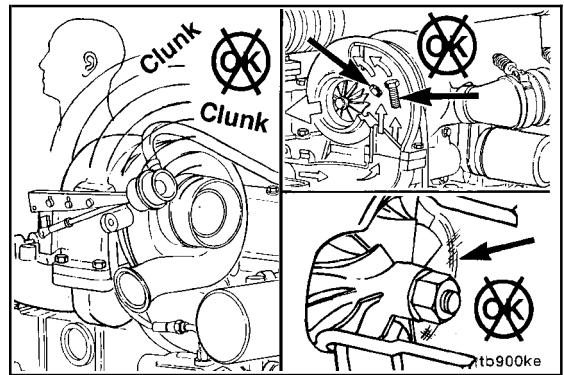

**Remove (010-033-002)**

- Remove the air crossover tube, if used.
- Disconnect the charge air cooler hose.
- Disconnect the boost capsule actuator hose.
- Disconnect and remove the exhaust and intake air piping.

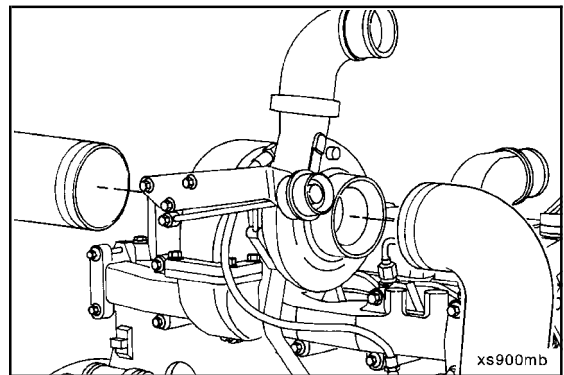

**16 mm and 19 mm**

Remove the turbocharger lubricating oil supply line from the turbocharger and oil filter head.



**NOTE:** Engines built after June 1993 can use a copper washer in both ends of the turbocharger lubricating oil supply line. The washer should be replaced whenever the line is removed.

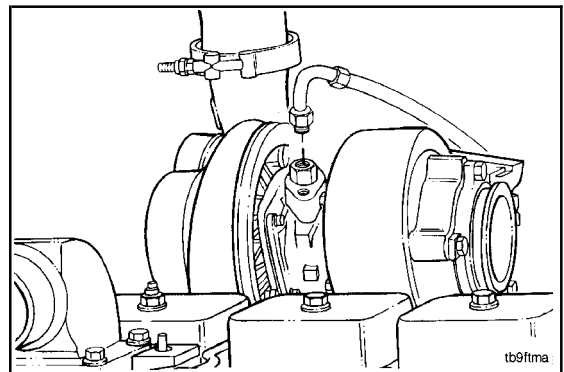

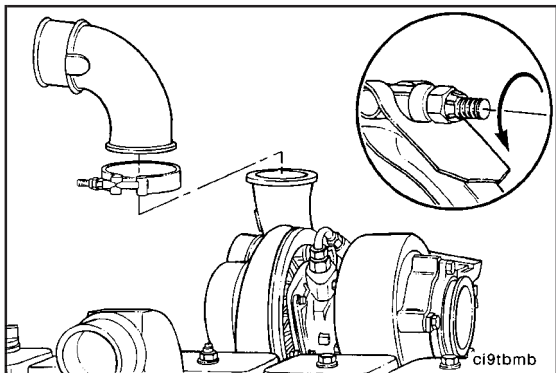

**Screwdriver or 7/16-Inch Wrench**

Remove the air crossover tube or charge air cooler piping from the turbocharger.

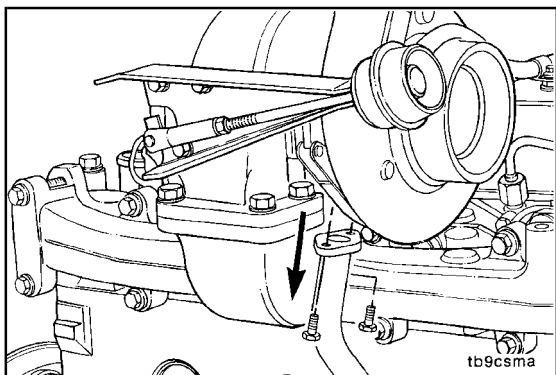

**10 mm**

Disconnect the lubricating oil drain tube from the bottom of the turbocharger.

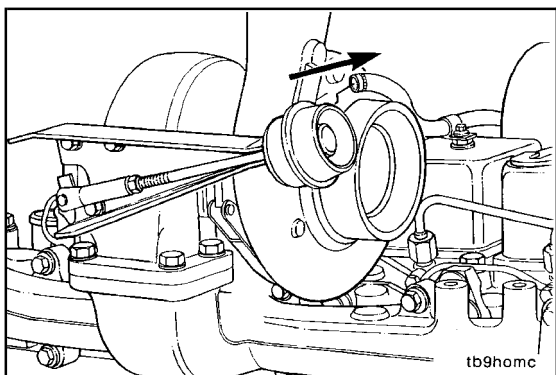

**Screwdriver**

Disconnect the hose from the turbocharger wastegate.

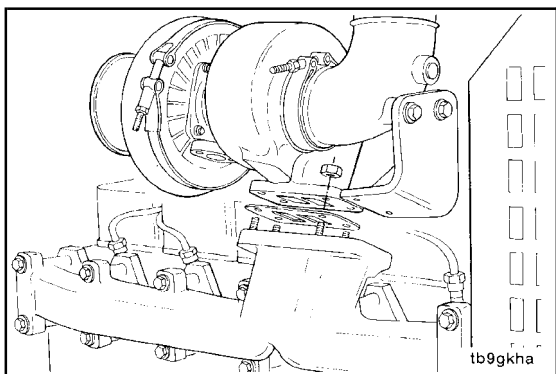

**15 mm**

Remove the exhaust clamp, turbocharger mounting nuts, turbocharger, and gasket.



**Clean (010-033-006)**

**▲ WARNING ▲**

Wear appropriate eye and face protection when using compressed air. Flying debris and dirt can cause bodily injury.

**▲ WARNING ▲**

When using a steam cleaner, wear safety glasses or a face shield, as well as protective clothing. Hot steam can cause serious personal injury.

**▲ WARNING ▲**

When using solvents, acids, or alkaline materials for cleaning, follow the manufacturer's recommendations for use. Wear goggles and protective clothing to avoid personal injury.

**▲ CAUTION ▲**

Tape or plug all openings to prevent solvent or steam from damaging the oil cavities in the turbocharger.

Remove all carbon deposits and gasket material from surfaces (1), (2), and (3).

Use solvent or steam to clean the exterior of the turbocharger. Dry with compressed air.

**NOTE:** If the turbocharger is **not** to be immediately replaced, cover the opening to prevent any material from falling into the manifold.

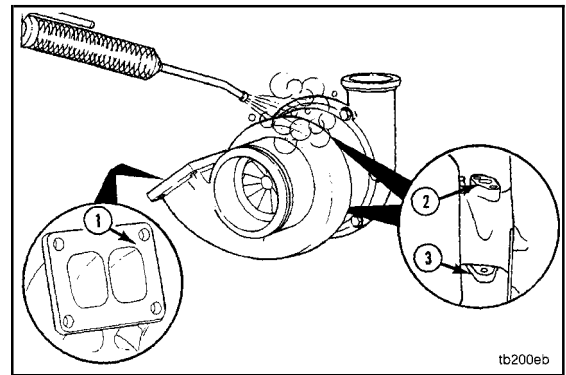

**Inspect for Reuse (010-033-007)**

Inspect the sealing surface and mounting studs for damage.

Inspect the turbocharger.

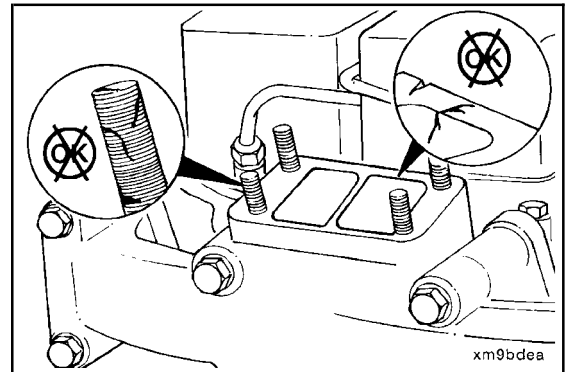

Inspect turbocharger wastegate linkage, valve shaft, module, and pressure signal line.

Inspect the turbocharger impeller blades for damage. If the impeller is damaged, inspect the intake piping and filter element for damage.

Check or calibrate wastegate. Refer to Procedure 010-050 or to the Turbocharger Shop Manual, Bulletin No. 3810321.

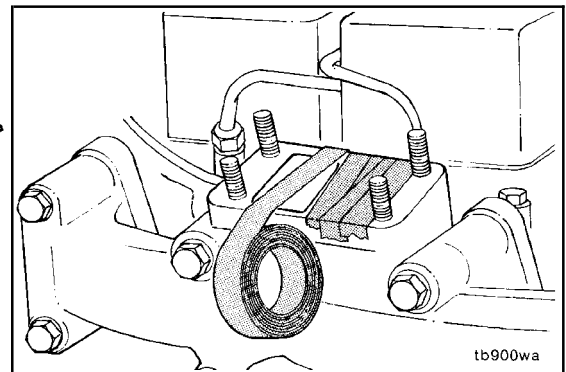

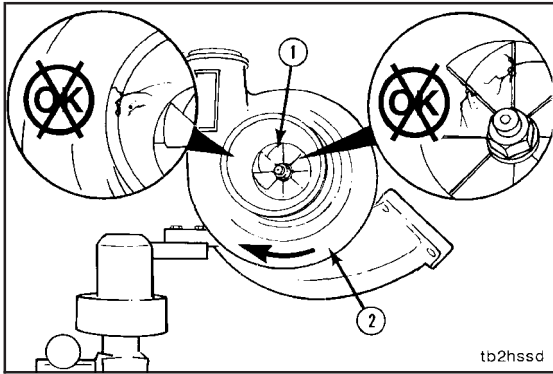

Inspect the housing for damage.

Inspect the turbine wheel and compressor impeller (1) for fretting or for cracked or broken vanes.

Turn the impeller in the direction shown with the arrow (2) to inspect the turbine shaft for freedom of rotation. The shaft **must** rotate freely.

Replace damaged parts.

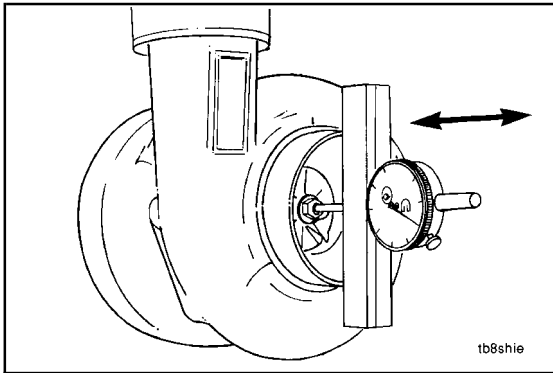

**Dial Depth Gauge, Part No. ST537**

Measure the turbocharger shaft end clearance with the dial depth gauge, Part No. ST537.



Push the rotor assembly away from the gauge.

Set the gauge on zero.

Push the rotor assembly toward the gauge and record the data.

End Play		
mm		in
0.03	MIN	0.001
0.08	MAX	0.003

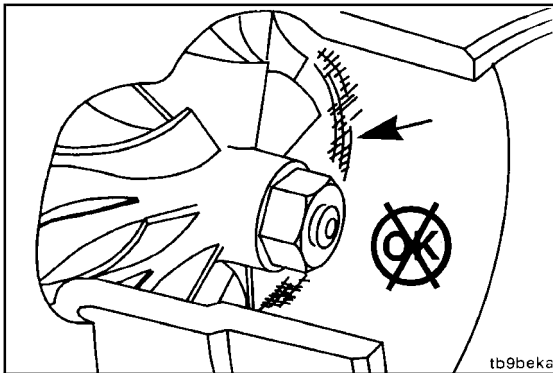

Failure of the internal components of the turbocharger can reduce its effectiveness and also cause excessive smoke and low power. A bearing failure can produce friction, which will slow the speed of the rotor assembly. Failed bearings can also allow the blades of the rotor assembly to rub the housings, thus reducing the rotor assembly speed.

Malfunctioning turbocharger wastegate failure or miscalibration of the turbocharger wastegate can result in excessively high or low boost pressures. Low boost pressures can cause excessive smoke and low power. High boost pressures can cause major engine damage.

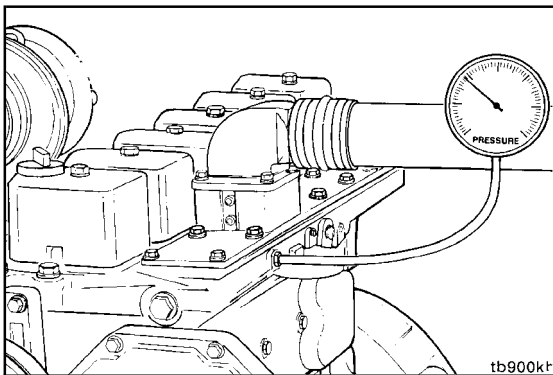

**Measure (010-033-010)**

Measure the boost pressure at the intake manifold by using one of the tapped or plugged intake access holes shown in the illustration. Refer to the specifications in this section.

**NOTE:** If the engine has charge-air-cooling, testing **must** be done to make certain that the charge-air-cooler system is **not** leaking or restricting the turbocharger boost pressure. Refer to Procedure 010-027 for charge-air-cooler testing.



**B3.9 and B5.9 Series Engines  
Section 10 - Air Intake System - Group 10**

Exhaust leaks can usually be detected audibly or visually by a discoloration caused by the escaping hot gases.

Do **not** overlook exhaust restriction as a cause of low power. If the exhaust gases can **not** flow freely, the turbocharger will **not** operate efficiently.

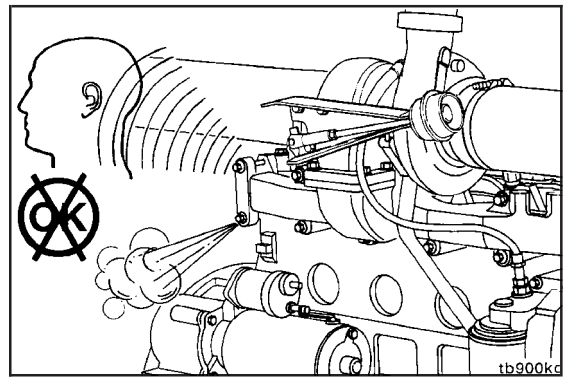

**Install (010-033-026)**

Install a new gasket, and apply anti-seize compound to the mounting studs.

**NOTE:** Use **only** lead-free anti-seize compound compatible with oxygen sensors.

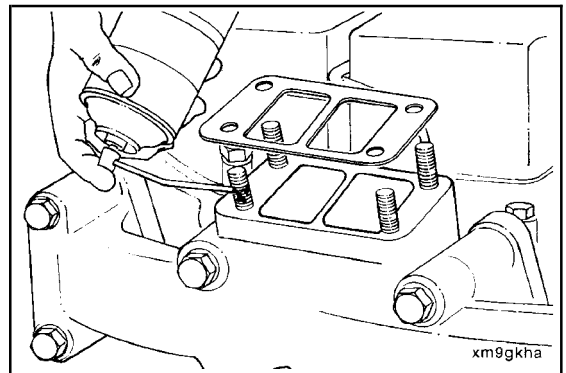

**15 mm**

Install the turbocharger.

**Torque Value:** 45 N•m [33 ft-lb]

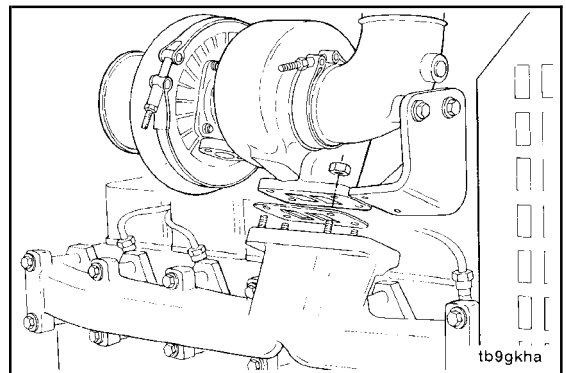

**10 mm and 7/16 Inch**

Use a new gasket and connect the oil drain tube.

**Torque Value:** 24 N•m [18 ft-lb]

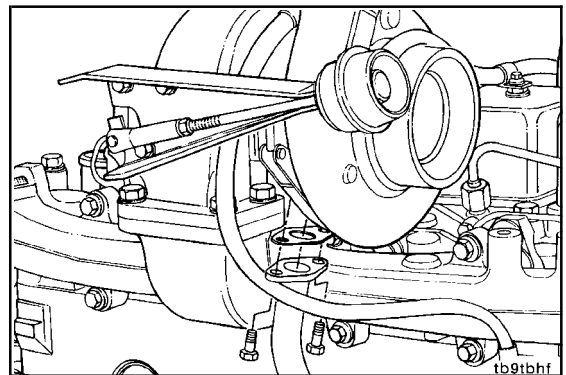

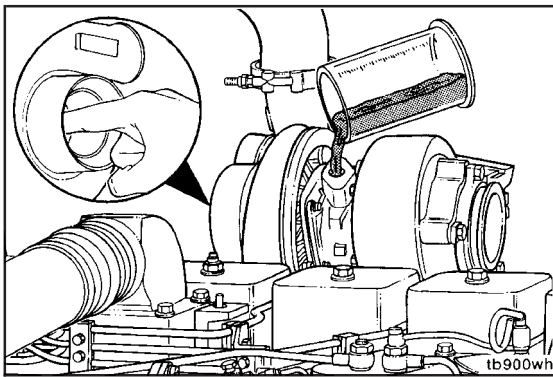

**NOTE:** New turbochargers **must** be prelubricated before start-up.

Pour 50 to 60 cc [2 to 3 oz] of clean engine oil into the oil supply fitting. Rotate the turbine wheel to allow the oil to enter the bearing housing.

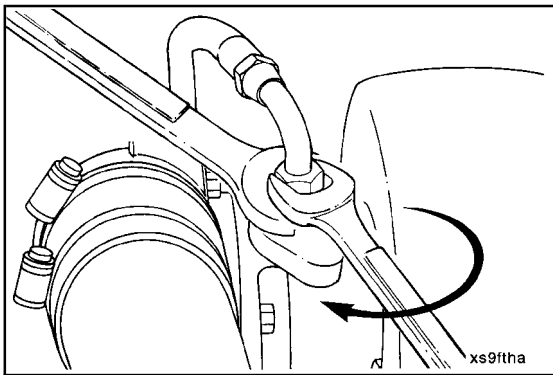

**16 mm**

Connect the oil supply line.



**Torque Value:** 35 N•m [26 ft-lb]

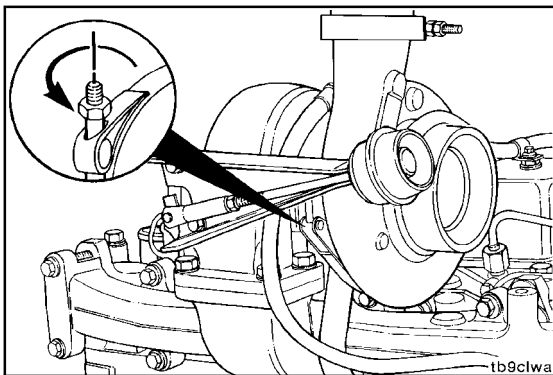

**7/16 Inch**

If required, loosen the compressor housing v-band clamp and position the housing to align with the turbocharger air outlet tube.

If required, loosen the snap ring and align the compressor housing with the turbocharger air outlet connection.

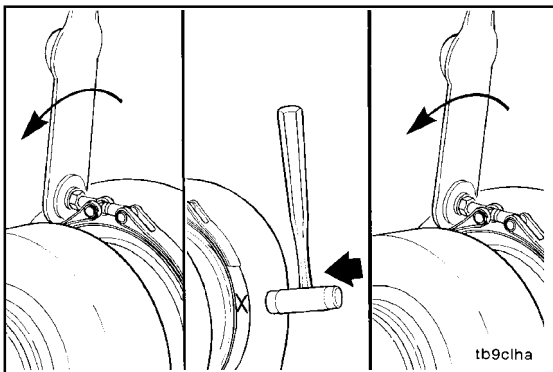

**7/16 Inch, Plastic Hammer**

Tighten the band clamp. Tap around the clamp with a plastic hammer and tighten again.



**Torque Value:** 8 N•m [71 in-lb]

**NOTE:** Effective October 1, 1990, all Holset® Turbochargers use silver-plated nuts with the v-band clamp. The silver-plated nuts require a **lower** torque than the stainless steel nut to provide the same v-band clamp load.

Install the boost control capsule actuator hose.

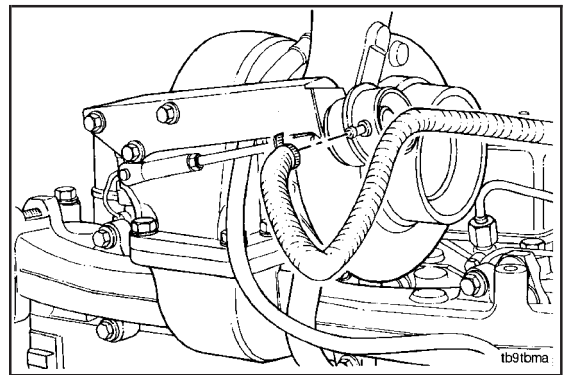

Install charged air cooler hose.

Install the air inlet and exhaust piping.

**Torque Value:** 8 N•m [71 in-lb]

Fill the cooling system. Refer to Procedure 008-018.

Operate the engine, and check for leaks.

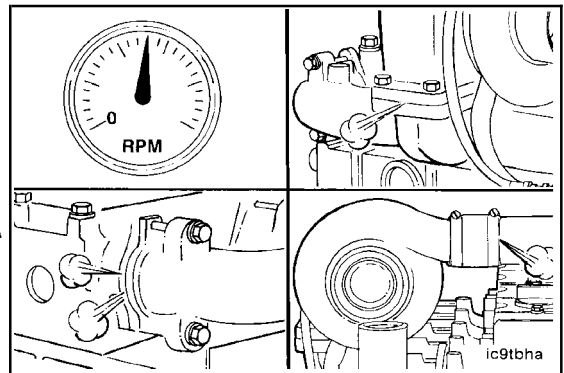

**Turbocharger Axial Clearance (010-038)**

**Measure (010-038-010)**

**Dial Depth Gauge, Part No. ST-537**

Measure the shaft end play.

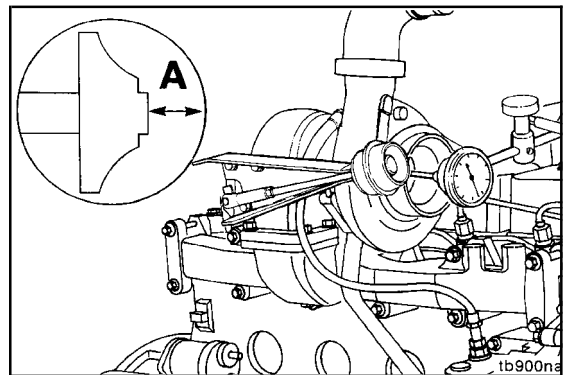

Turbocharger Shaft End Play			
	mm		in
*	0.10	MIN	0.004
	0.16	MAX	0.006
**	0.03	MIN	0.001
	0.08	MAX	0.003

\* For turbochargers with a serial number **before** 840638.

\*\* For turbochargers with a serial number 840638 and **after**.

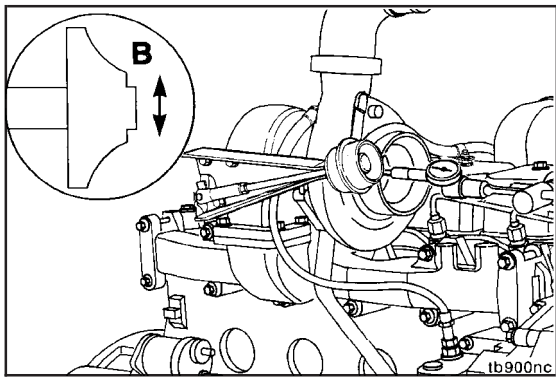

Measure radial clearance of the shaft.



Radial Bearing Clearance		
mm		in
0.30	MIN	0.012
0.46	MAX	0.018

The turbocharger **must** be removed for replacement or rebuild if the clearances are beyond these limits. Refer to the Turbocharger Master Repair Manual, Bulletin No. 3580555, for rebuild procedures.

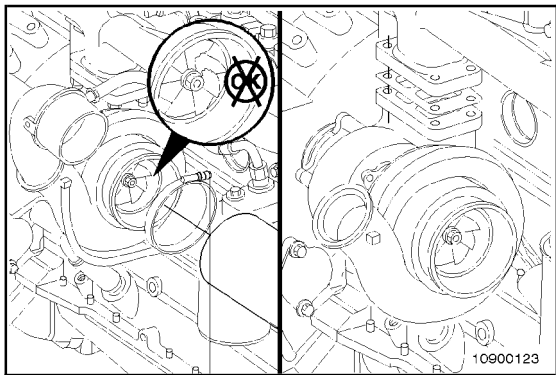

**Turbocharger Blade Damage (010-039)**  
**Inspect for Reuse (010-039-007)**



Remove the intake pipe from the turbocharger.

Inspect the turbocharger compressor impeller blades for damage.



Replace the turbocharger if damage is found. Refer to Procedure 010-033.

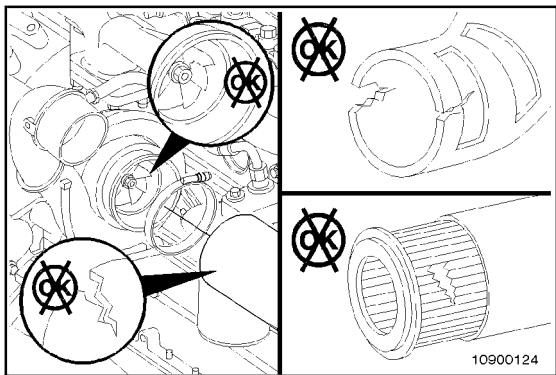

If the compressor impeller is damaged, inspect the intake piping and filter element for damage.

Repair any damage before operating the engine.

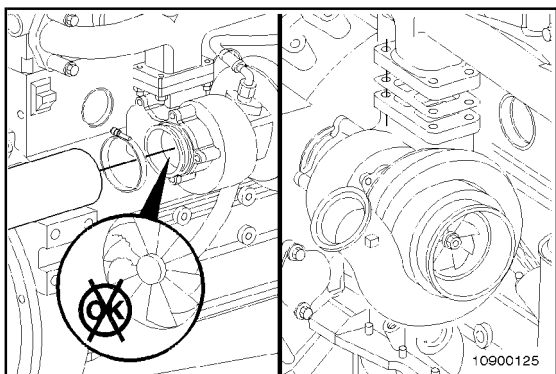

Remove the exhaust pipe from the turbocharger.

Inspect the turbine wheel for damage.



Replace the turbocharger, if damage is found. Refer to Procedure 010-033.



Install the intake pipe and tighten the clamp.  
 Install the exhaust pipe and tighten the clamp.

**Torque Value:** 8 N•m [71 in-lb]

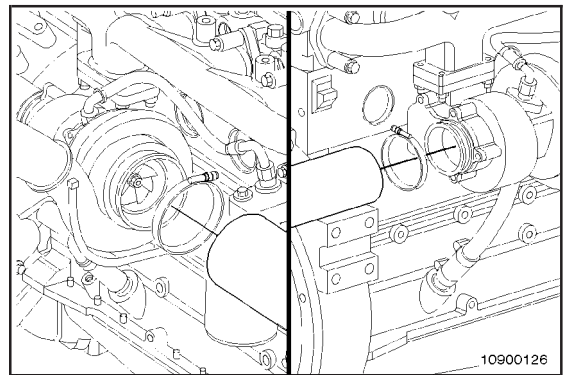

**Turbocharger Compressor Seal Leaks (010-040)**

**Leak Test (010-040-014)**

Remove the air intake and charge air cooler (CAC) piping from the turbocharger.

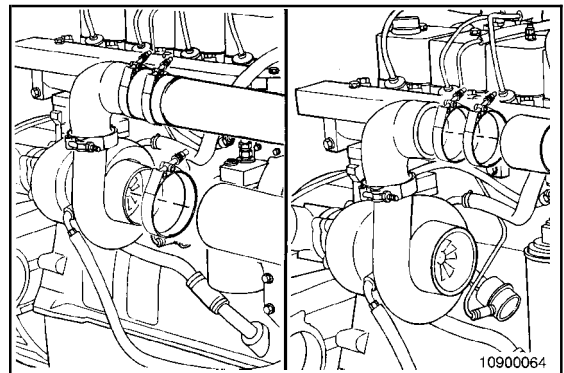

Inspect the compressor intake and discharge for oil.

If oil is present in the compressor intake, as well as in the discharge, check upstream of the turbocharger for the source of the oil.

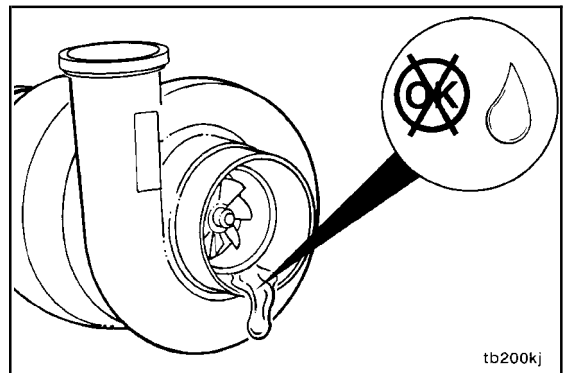

If oil is present **only** in the discharge side, install the air intake and CAC piping.

Check for intake restriction. Refer to Procedure 010-031.

If no intake restriction is found, replace the turbocharger. Refer to Procedure 010-033.

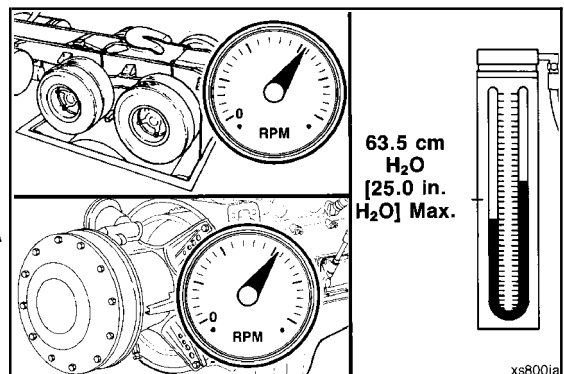

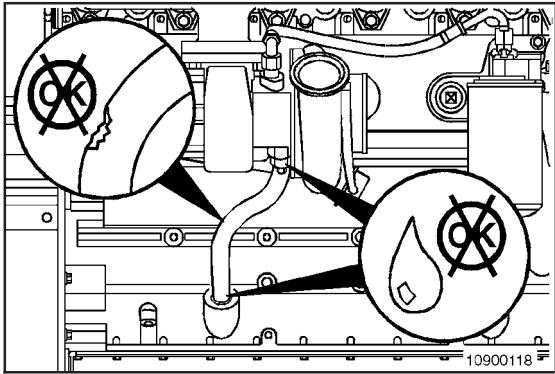

**Turbocharger Oil Drain Line (010-045)  
Initial Check (010-045-001)**

Inspect the line for oil leaks or damage.  
Repair or replace as necessary.

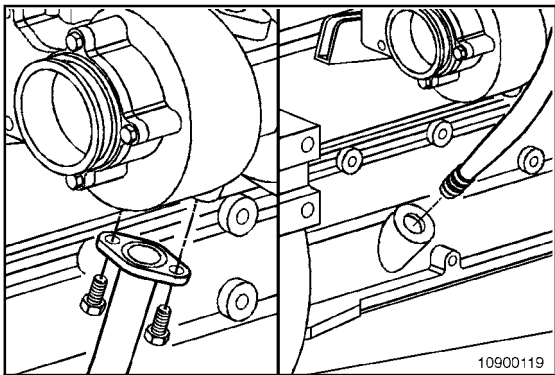

**Remove (010-045-002)**

Remove the capscrews from the turbocharger oil drain tube.  
Pull the drain line out of the drain line boss.

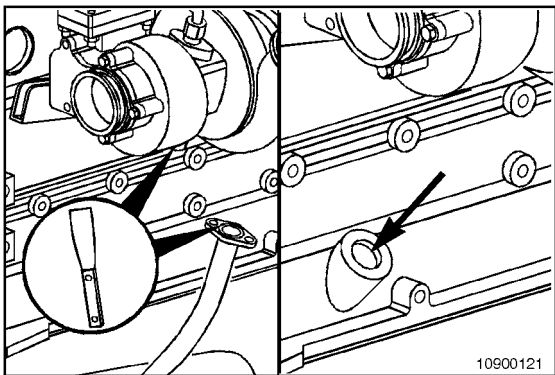

**Clean (010-045-006)**

Clean the gasket sealing surfaces (first frame).  
Clean the o-ring seating bore, and make sure it is free of dirt and debris.

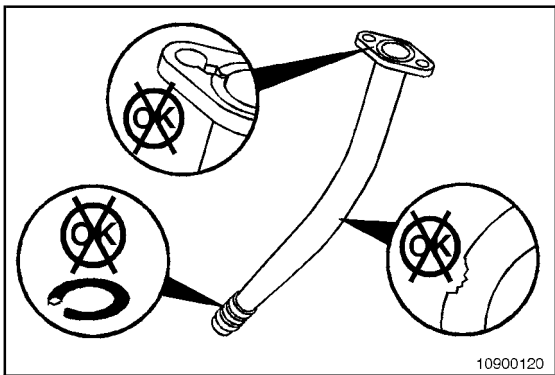

**Inspect for Reuse (010-045-007)**

Inspect line for cracks, wear, and damage.  
Inspect the o-ring for fretting and cracking, and replace as necessary.  
Check the rubber section of the drain line for deterioration.

**Install (010-045-026)**

Apply a thin film of oil to the drain line o-rings.  
 Push the drain line into the drain line boss. Be sure both o-rings are completely seated in the bore.  
 Install the drain line capscrews with a new gasket.  
**Torque Value:** 24 N•m [18 ft-lb]  
 Operate the engine, and check for leaks.

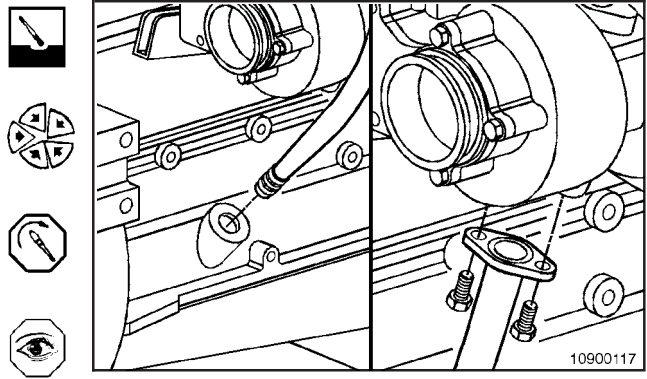

**Turbocharger Oil Supply Line (010-046)**

**Initial Check (010-046-001)**

Inspect the line for oil leaks or damage. Replace as necessary.

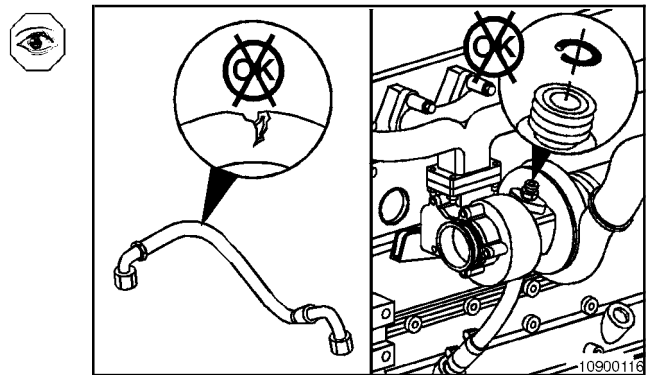

**Remove (010-046-002)**

Remove the oil supply line from the oil filter head (1).  
 Remove the oil supply line from the turbocharger bearing housing (2).

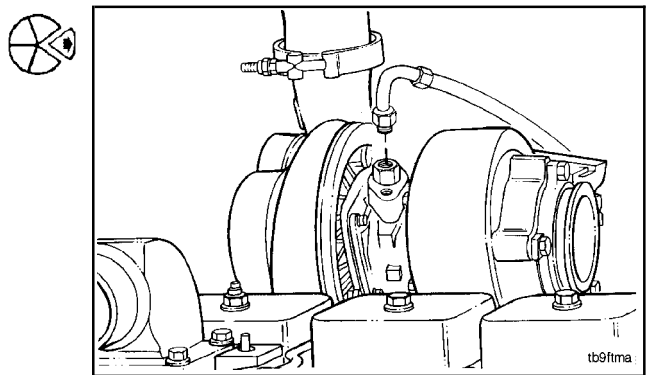

**Inspect for Reuse (010-046-007)**

Inspect the line for cracks, wear, and damage.  
 Inspect o-rings for cracking and fretting. Replace as necessary.

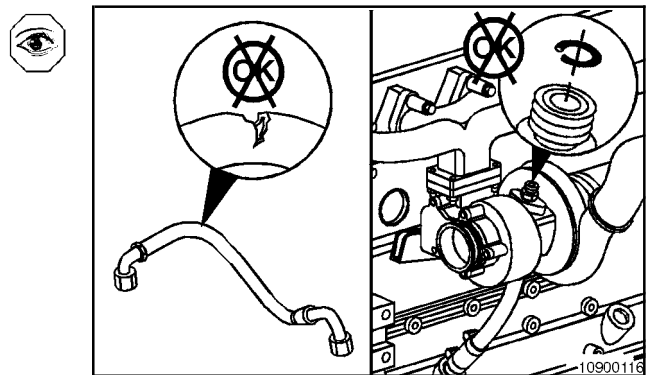

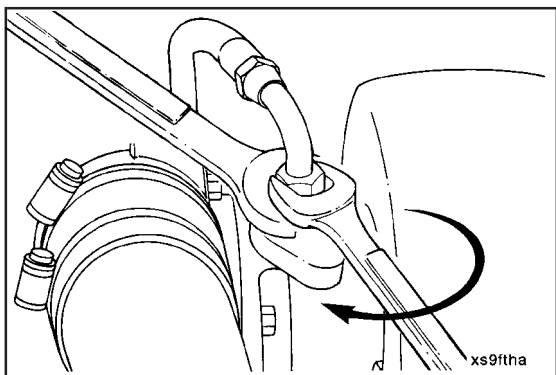

**Install (010-046-026)**

Apply a thin film of oil to the o-ring seals.



Fill the turbocharger oil inlet with clean oil.

Install the oil supply line at both the filter head and the turbocharger bearing housing.



Tighten the oil supply line to final torque.

**Torque Value:** 24 N•m [18 ft-lb]

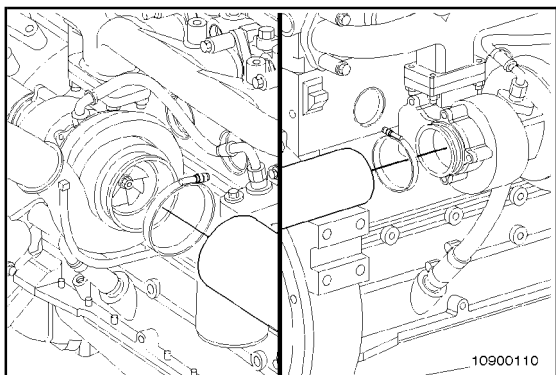

**Turbocharger Radial Bearing Clearance (010-047)**

**Measure (010-047-010)**

Remove the intake and exhaust pipes from the turbocharger.

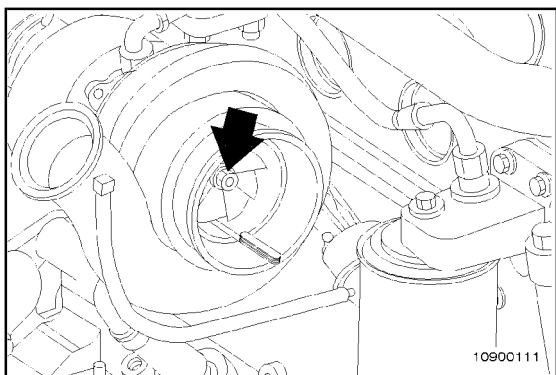

Use a narrow blade or a wire-type feeler gauge to measure the clearance between the compressor wheel and housing.

Gently push the compressor wheel toward the compressor housing and gauge.

Record this clearance.

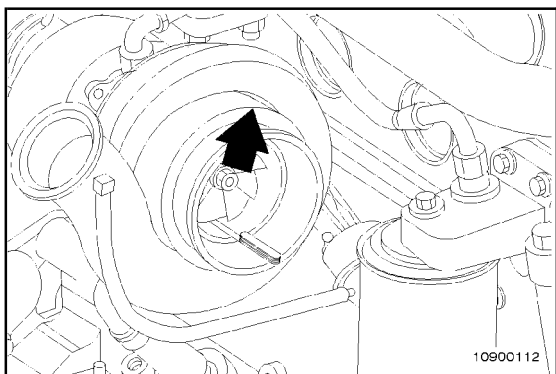

With the feeler gauge in the same location, gently push the compressor wheel away from the compressor housing, and measure the clearance between the compressor wheel and housing.

Record this clearance.



**B3.9 and B5.9 Series Engines  
Section 10 - Air Intake System - Group 10**

**Turbocharger Turbine Seal Leaks (010-049)  
Page 10-43**

Subtract the smaller clearance from the larger clearance.  
This is the radial bearing clearance.

Radial Bearing Clearance		
mm		in
0.30	MIN	0.012
0.46	MAX	0.018

Replace the turbocharger if the radial bearing clearance does **not** meet the specifications. Refer to Procedure 010-033 for the replacement procedure.

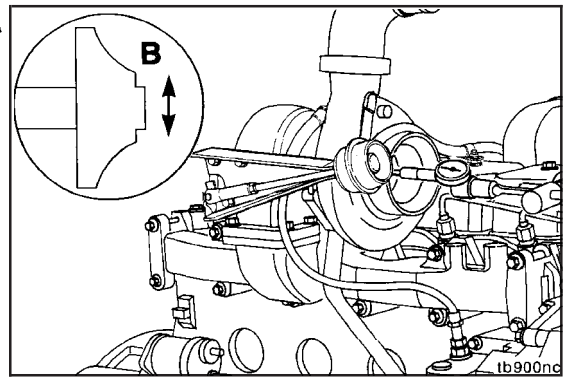

Install the intake pipe, and tighten the clamp.  
Install the exhaust pipe, and tighten the clamp.  
**Torque Value:** 8 N•m [71 in-lb]

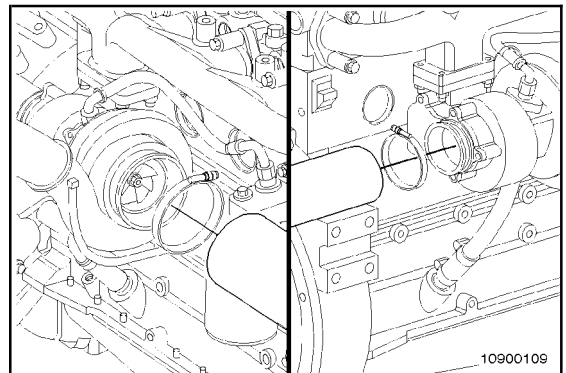

**Turbocharger Turbine Seal Leaks (010-049)**

**Leak Test (010-049-014)**

**Fluorescent Tracer, Part No. 3376891**

Add 1 unit of fluorescent tracer, Part No. 3376891, to engine lubricating oil.

**Engine Lubricating Oil:** 38 liters [10 U.S.gal]

Operate the engine at low idle for 10 minutes.

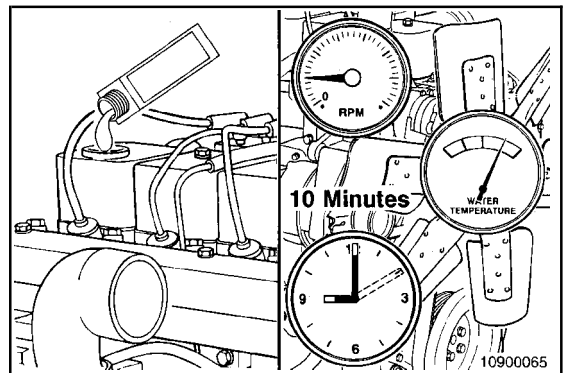

Shut off the engine.  
Allow the turbocharger to cool.  
Remove the exhaust pipe from the turbine housing.

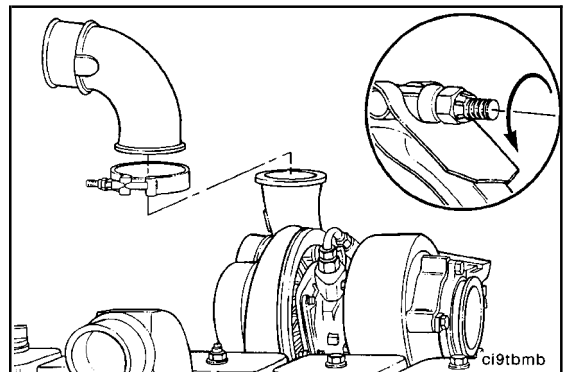

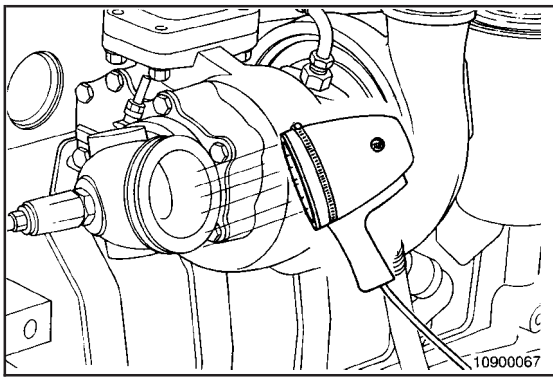

**Black Light (DC), Part No. 3824754**

Use a high-intensity black light, Part No. 3377253 or 3377394, to inspect the turbine outlet for leaks.



A dark blue glow indicates a fuel leak. Refer to Procedure 007-044. A yellow glow indicates an oil leak.

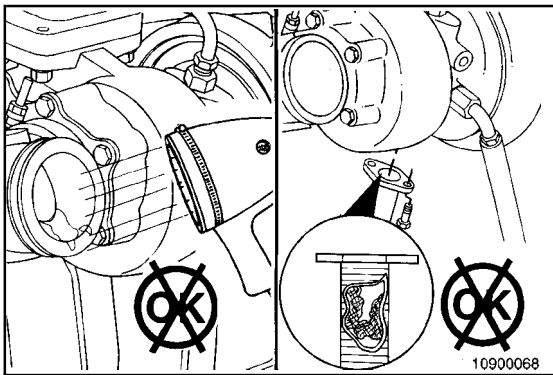

If oil is found on the turbine housing, remove the oil drain line, and check for restrictions. Clear any restrictions found, or replace damaged components as required.



If the engine is equipped with a turbocharger oil drain fitting with a screen, remove the fitting, and check to make sure the screen is clean.

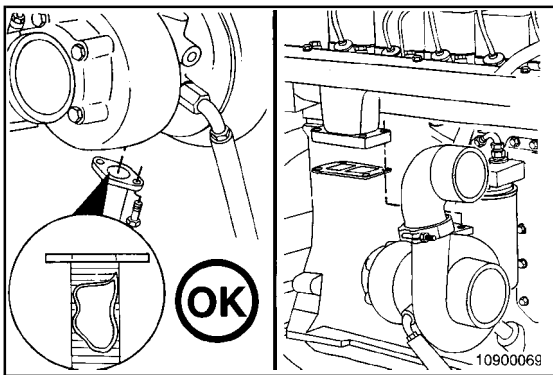

If the oil drain line is **not** restricted, remove the turbocharger. Refer to Procedure 010-033.

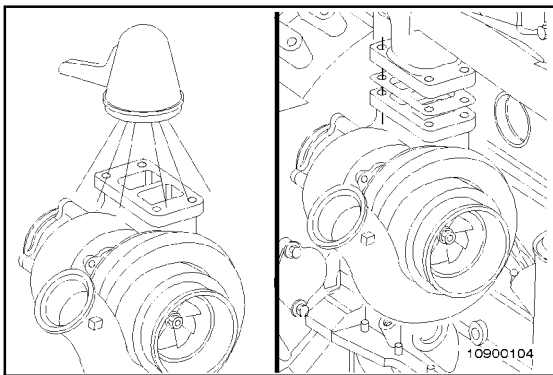

**Black Light, Part No. 3829754 or 3824524**

Use a high-intensity black light, Part No. 3829754 or 3824524, to inspect the turbine inlet for leaks.



A yellow glow indicates an oil leak from the engine.



If a yellow glow is **not** seen in the turbine inlet, replace the turbocharger. Refer to Procedure 010-033.



Install the exhaust pipe to the turbocharger and tighten the clamp.

**Torque Value:** 8 N•m [71 in-lb]

Operate the engine, and check for air leaks.

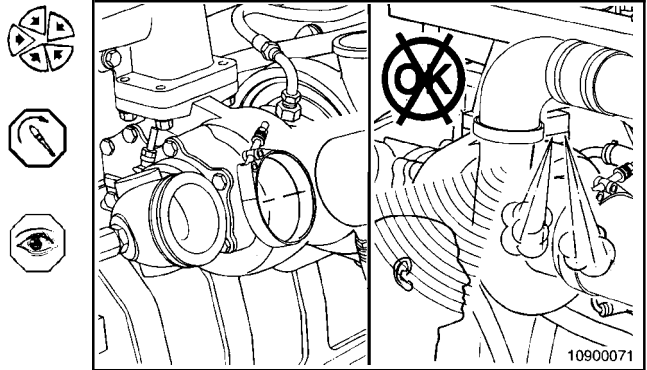

**Turbocharger Wastegate Actuator (010-050)**

**Initial Check (010-050-001)**

**NOTE:** This procedure applies to actuators that are adjustable before pre-1998 B Series engines. B Series engines after January 1998 are **not** adjustable and the actuators are tamper proof.

Some versions of B Series engines are equipped with wastegated turbochargers to limit the peak boost level and increase engine response at low rpm.

The integral wastegate line takes boost from the turbocharger compressor outlet to the wastegate capsule.

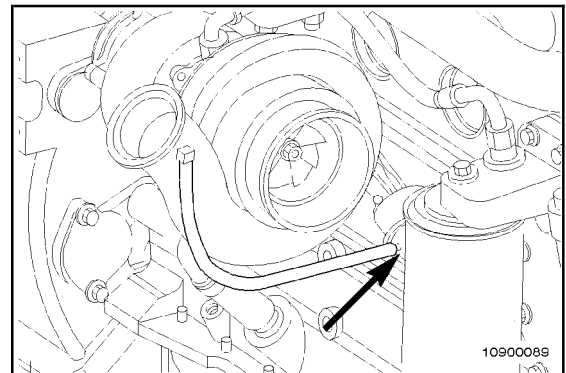

Inspect the integral wastegate actuator hose for cracks or holes.

Replace the hose if damaged.

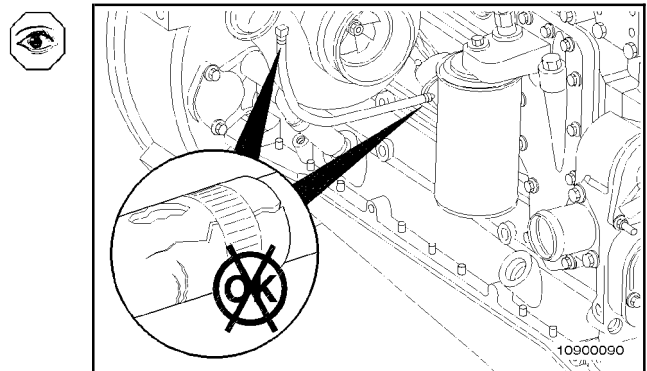

**▲ CAUTION ▲**

**A bent wastegate mounting bracket, actuator rod, or lever can cause improper operation.**

Inspect the wastegate mounting bracket, actuator rod, and lever for damage.

If the wastegate mounting bracket, actuator rod, or lever is bent, it **must** be replaced.

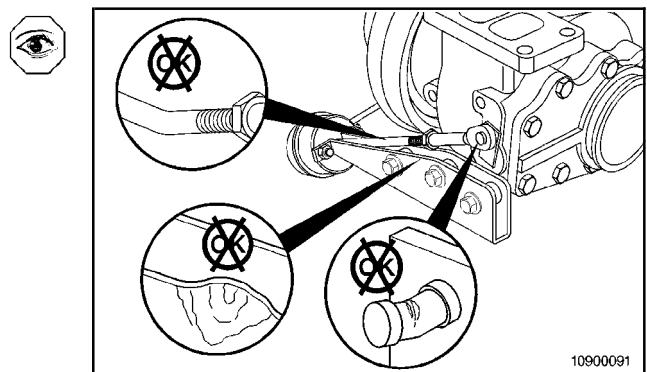

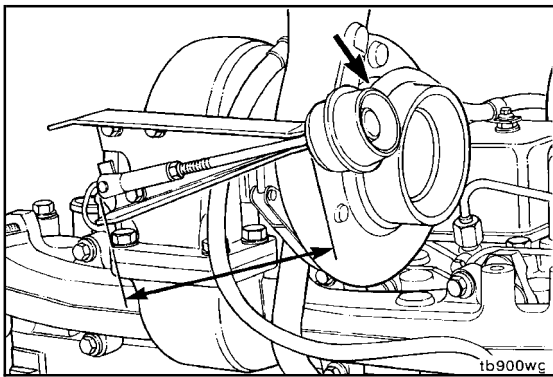

**Remove (010-050-002)**

**NOTE:** Prior to removal, note position length of the control rod from the boost capsule housing and orientation of the boost capsule hose connector in relation to the mounting bracket.

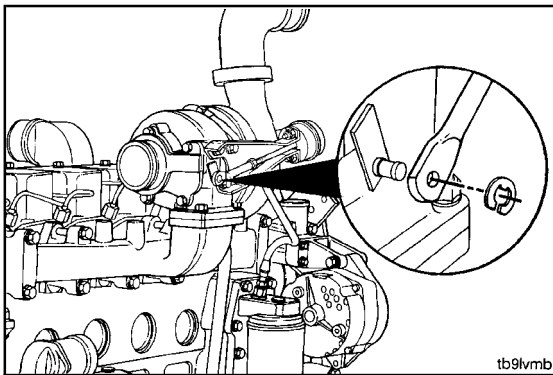

**Turbocharger Wastegate Pressure Setting Kit, Part No. 3823799**

Remove the retaining clip from the control lever.

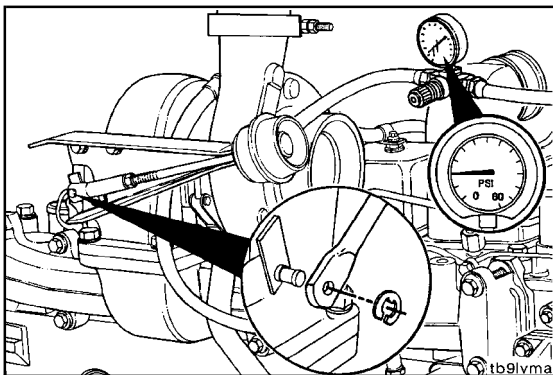

**⚠ CAUTION ⚠**

**Be careful not to bend the control lever.**

Disconnect the boost capsule actuator rod end from the turbocharger wastegate lever. This can be accomplished by applying regulated air pressure to the boost capsule in a sufficient amount to activate control rod movement.

Disconnect the control rod from the turbocharger wastegate lever pin.

**NOTE:** If the boost capsule diaphragm material is ruptured and will **not** hold air pressure other than by hand, manually pull the control rod outward in order to overcome boost capsule spring tension for removal of the control rod from the turbocharger wastegate lever pin.

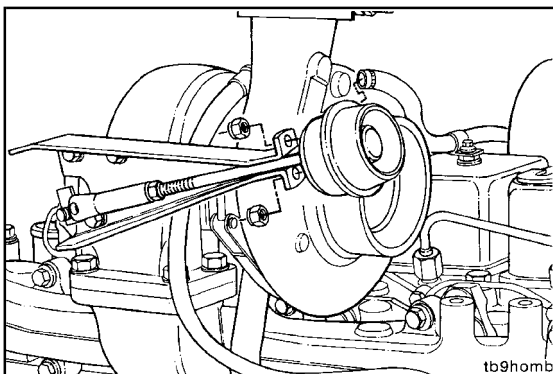

Loosen the boost capsule mounting cap screws, disconnect the air supply hose, and remove assembly from the mounting bracket.



**B3.9 and B5.9 Series Engines**  
**Section 10 - Air Intake System - Group 10**

**Turbocharger Wastegate Actuator (010-050)**  
**Page 10-47**

Note length of adjusting link prior to removal.

Loosen nut, and remove the adjusting link end from the boost capsule actuator.

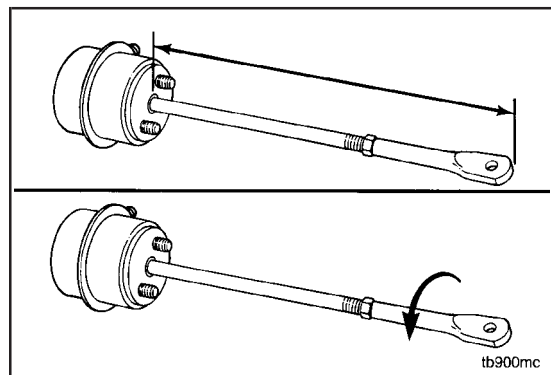

**Inspect for Reuse (010-050-007)**

Inspect the wastegate actuator hose for cracks or holes. Replace the hose if damaged.

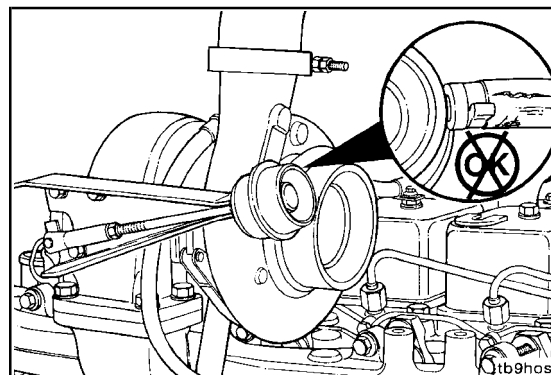

Inspect the wastegate mounting bracket, actuator rod, and lever for damage. A bent wastegate mounting bracket, actuator rod, or lever can cause improper operation.

If the wastegate mounting bracket, actuator rod, or lever is bent, it **must** be replaced.

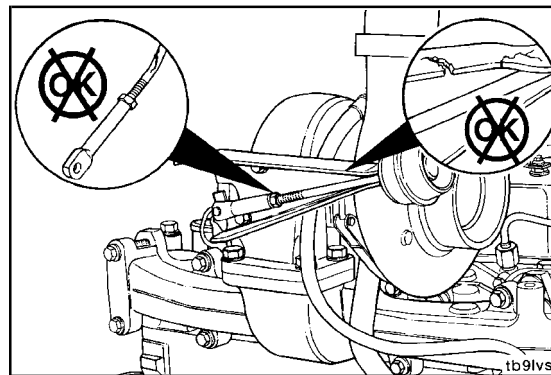

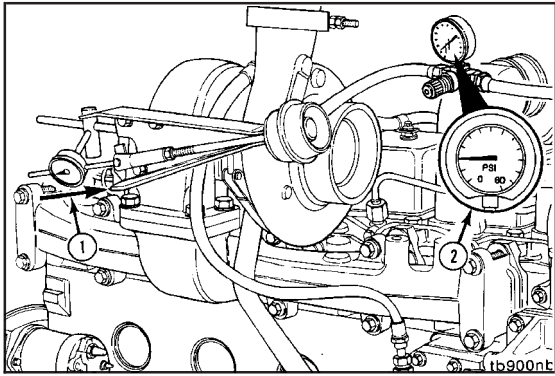

**Test (010-050-012)**

**Functional Check**

Attach a dial indicator as shown, so that its shaft is in line with the wastegate actuator rod. Set the indicator to zero, with no air pressure applied to the wastegate capsule.

Connect clean, regulated air pressure and a pressure gauge to the capsule. Apply air pressure to make sure the wastegate is functioning properly.

**Air Pressure:** 200 kPa [29 psi]

The rod should move without any sticking or air leakage.

**Rod:** 0.33 to 1.27 mm [0.013 to 0.050 in]

**NOTE:** No air should be heard leaking through a functional wastegate capsule.

**NOTE:** A small amount of travel when air pressure is first applied is normal; the tolerance is being removed from the system.

Replace the actuator if no movement of the actuator rod and lever is detected.

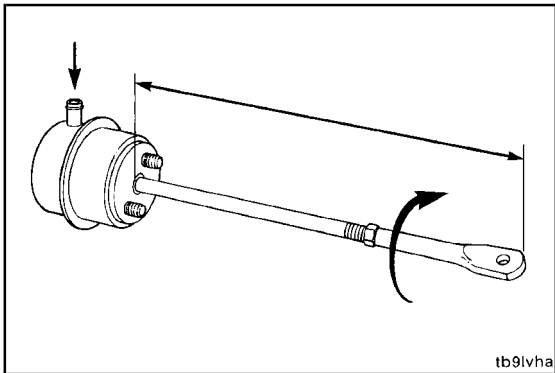
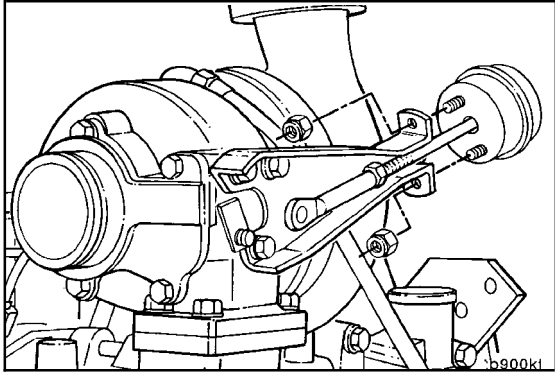

**Install (010-050-026)**

Install the adjusting link end onto the boost capsule actuator assembly. Adjust the rod to approximately the same length as when removed.

**B3.9 and B5.9 Series Engines  
Section 10 - Air Intake System - Group 10**

**Turbocharger Wastegate Actuator (010-050)  
Page 10-49**

Fit the new boost capsule actuator assembly to the actuator mounting bracket, and install the mounting capscrews.

**Torque Value:** 4.5 N•m [40 in-lb]

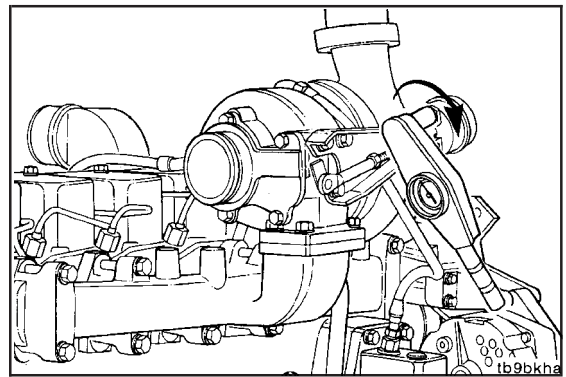

**Calibrate (010-050-030)**

**NOTE:** The wastegate is set accurately from the factory. Adjustment is **not** necessary unless the capsule is removed.

Connect clean, regulated air pressure to the boost capsule.

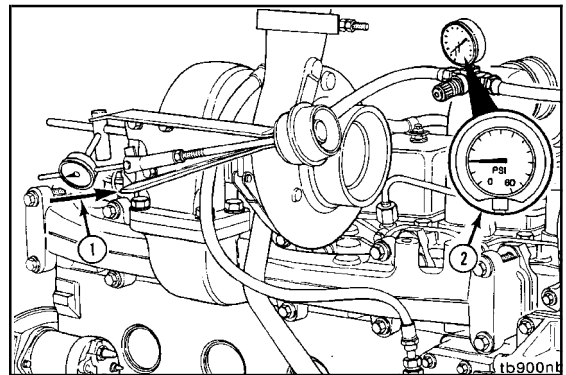

**NOTE:** Wastegate actuator adjustment is **not** a shortcut to diagnosing low boost. Use the appropriate symptom tree to diagnose the cause of the low boost before calibrating the wastegate actuator, if turbo boost is suspected.

This actuator travel specification applies to the 4B and 6B engine applications.

**NOTE:** If the measured wastegate actuator travel is within specification, do **not** make any adjustment.

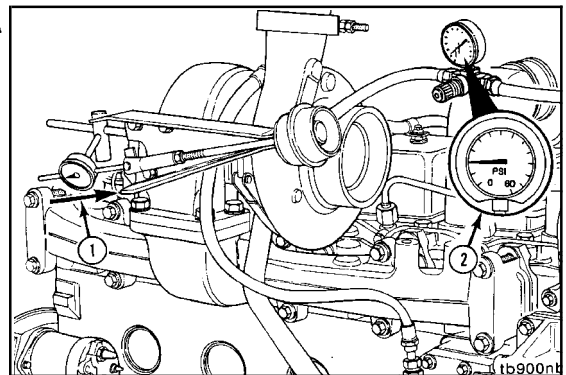

**Wastegate Actuator Travel Measurement**

mm		in
0.033	MIN	0.013
1.27	MAX	0.050

**NOTE:** Adjustment on wastegate actuators is **not** possible for engines that were built after January 1998 because tamper proof actuator links are used. The first engine serial number is 4536369. If the actuator needs to be replaced, the whole capsule has to be changed. You can **not** adjust the wastegate actuator.

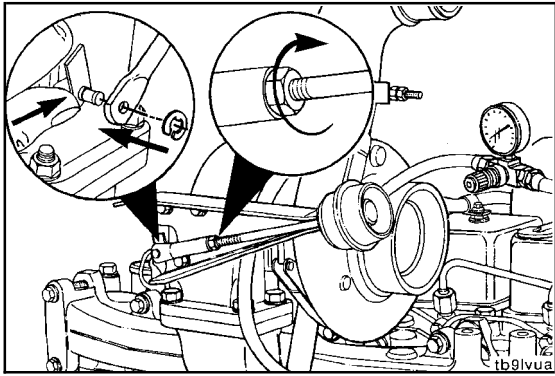

**CAUTION**

Do not pull, or push, or force alignment of the clevis pin. Failure to do so can cause component damage.



Adjust the wastegate, if necessary, to achieve specified travel.

- Pull the wastegate lever to the foremost closed position (lever toward boost capsule).
- Adjust the length of the clevis end of the control rod to where the clevis pin hole aligns to the wastegate lever.
- Install the adjusting link and retaining clip.
- After adjustment is completed, tighten actuator rod jam nuts.

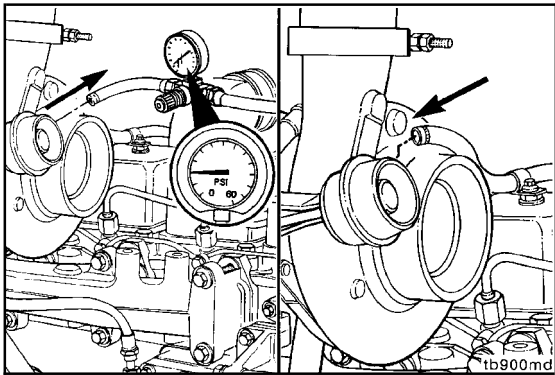

Disconnect regulated air pressure line from the boost capsule.



Connect the turbocharger boost line to the boost capsule, and secure the hose clamp.



If possible, a more accurate method of wastegate adjustment is to check the manifold pressure at rated rpm according to turbocharger boost pressure specifications.

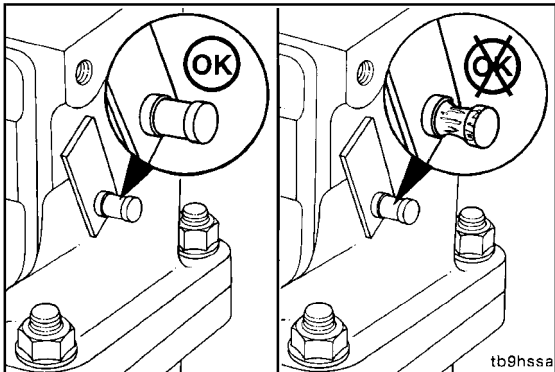

**Turbocharger Wastegate Valve Body (010-055)**



**Inspect for Reuse (010-055-007)**

Inspect the lever pin.

Replace the turbine housing assembly if worn excessively.

Refer to the Turbocharger Master Repair Manual, Bulletin No. 3580555.

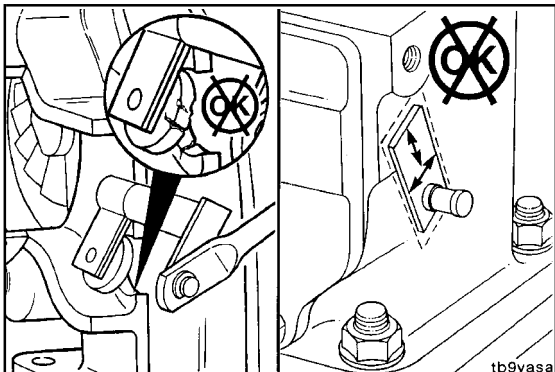

Inspect the valve and valve seat for cracks or erosion.

Replace the turbine housing assembly if worn excessively.



Refer to the Turbocharger Master Repair Manual, Bulletin No. 3580555.



**B3.9 and B5.9 Series Engines**  
**Section 10 - Air Intake System - Group 10**

Actuate the lever by hand to be sure that the shaft rotates freely and is **not** seized.

Check for excessive movement between the shaft and bushing.

Replace the turbine housing if the shaft and bushing are damaged or seized.

Refer to the Turbocharger Master Repair Manual, Bulletin No. 3580555.

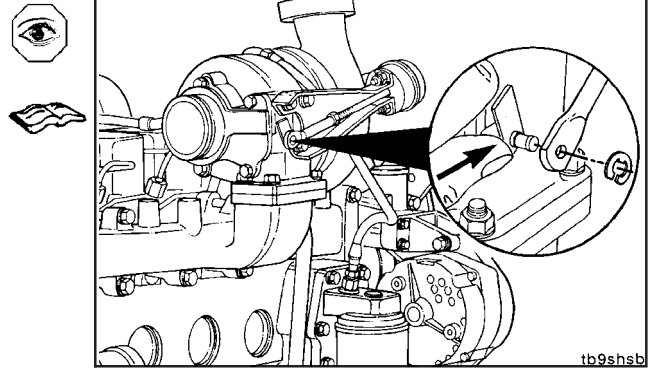

## Air Intake Manifold Heater (010-072)

### General Information

#### WARNING

To avoid personal injury and property damage, never use starting fluid with the air intake manifold heater. Starting fluid, which contains ether, can cause an explosion.

#### WARNING

Starting fluid is highly flammable and explosive. Keep flames, sparks, and arcing switches away from starting fluid. This combination can cause an explosion and bodily injury.

Warning labels, Part No. 3927335, **must** be installed in locations obvious to the operator, near the most likely point of entry of ether, and on a visible side of the heater. The sun visor and the air cleaner intake would be two examples.

The 12-VDC B Series charge air cooled, turbocharged, and naturally aspirated engines (6BTAA, 6BT, and 6B) use the air intake manifold heater as a cold weather starting aid. There is no air intake manifold heater for the water jacket aftercooled engine (6BTA) or 24-VDC electrical system at this time, and the air intake manifold heater is **not** compatible with marine applications.

Benefits from an air intake manifold heater include:

- Quicker start times
- Smoother engine running after starting
- Replaces ether as a starting aid
- Extends starter and battery life through less cranking.

The air intake manifold heater is very similar to the popular light-duty truck application grid heater in use since 1988. This heater electronically controls the two heating elements to optimize cold weather starts and improved cold engine running.

Engine mounted hardware includes:

- Air intake manifold heater
- Temperature sensor
- Controller
- Wiring harness.

**NOTE:** The kit does **not** include 6 AWG wire or ring terminals needed for the battery and other connections.

White smoke indicates unburned fuel during cold engine operation.

The intake manifold heater system is **not** directly connected to the fuel system, but it monitors the temperature of the air to the engine. The thermistor sends varying resistance values to the electronic control module, or equivalent. The ECM in turn controls the WAIT-TO-START lamp and the heater solenoids.

The intake manifold heater elements operate in both the preheat and postheat modes.

- In preheat, the ignition switch is on, but the engine has **not** been started.
- In postheat, the engine is running.

The proper operation of the intake manifold heater system and starting procedures will preclude excessive engine starter motor use and minimize white exhaust smoke when the engine is first started.

Normal Operation of the Intake Manifold Heater System

Temperature	Condition	Elements	Duration	Duty Cycle Percent ON/OFF
Below -19°C [-2°F]	Preheat	Both	30 seconds	Continuous
		Postheat	Both	15 seconds
	Postheat	One	15 seconds	Continuous
		One	40 seconds	50/50
		One	106 seconds	25/75
-19 to -8°C [-2 to 18°F]	Preheat	Both	20 seconds	Continuous
		Postheat	Both	20 seconds
	Postheat	One	20 seconds	Continuous
		One	20 seconds	Continuous
		One	40 seconds	50/50
		One	106 seconds	25/75
		One	106 seconds	25/75
-8 to 8°C [18 to 46°F]	Preheat	Both	10 seconds	Continuous
		Postheat	Both	10 seconds
	Postheat	One	10 seconds	Continuous
		One	10 seconds	Continuous
		One	40 seconds	50/50
		One	106 seconds	25/75
Below 8°C [46°F]	Preheat	None		
	Postheat	None		

Amperage Draw - 95 amps per element

To prevent excessive drain on the batteries, the electric heater controller has incorporated a battery monitoring feature. If the battery VDC were dropped too low, the heater controller would delay the postheat cycle, preventing further drain on the batteries. This battery protection feature is **only** activated on vehicles with weak or drained batteries.

\*Heater control modules/electronic control modules with serial numbers below 0080000A will **not** have a preheat cycle during this cycle.

Battery Size Requirements for B Series Engines (automotive and industrial ratings)

1991 and 1994 6BTAA and 4BTAA automotive ratings

**NOTE:** Unaided starting down to 0°C [+ 32°F] or intake heater equipment\*

4BTAA Engine		
	Cold Cranking Amps (CCA)	Reserve Minutes
Heavy accessory	900	160
Light accessory	750	169

\* Intake heater equipment option requires a 95-amp alternator or larger.

6BTAA Engine		
	Cold Cranking Amps (CCA)	Reserve Minutes
Heavy accessories	1000	160
Light accessories	850	160

\* Intake heater equipment option requires a 95-amp alternator or larger.

**NOTE:** Unaided starting down to -12°C [10°F].

4BTAA Engine		
	Cold Cranking Amps (CCA)	Reserve Minutes
Heavy accessories	1350	320
Light accessories	1125	320

6BTAA Engine		
	Cold Cranking Amps (CCA)	Reserve Minutes
Heavy accessories	1500	320
Light accessories	1250	320

1994 6BTAA and 4BTAA industrial ratings

4BTAA Engine		
	Cold Cranking Amps (CCA)	Reserve Minutes
Heavy accessories	800	160
Light accessories	625	160

6BTAA Engine		
	Cold Cranking Amps (CCA)	Reserve Minutes
Heavy accessories	950	160
Light accessories	800	160

**NOTE:** Typical "light accessories" include alternator, small steering pump, and disengaged clutch.

**NOTE:** Typical "heavy accessories" include hydraulic pump and torque convertor.

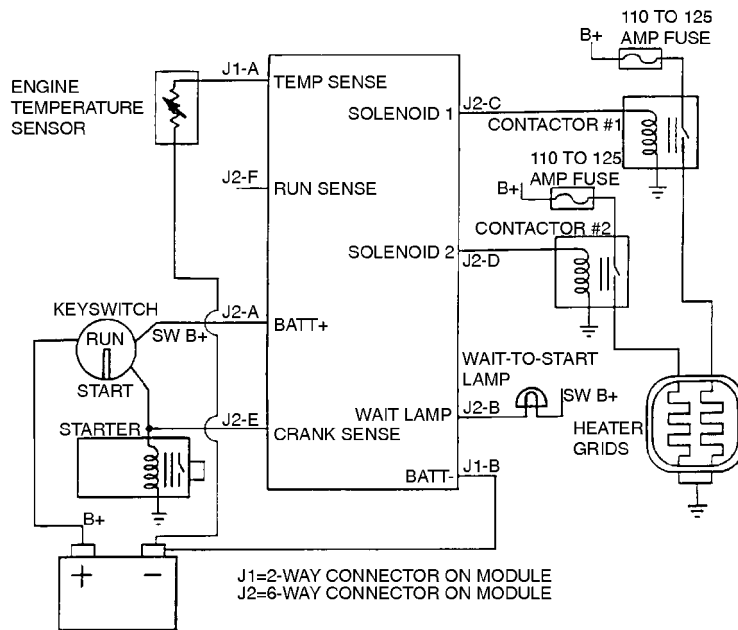

10900270

**Air Intake Heater Controller Interconnection Diagram**

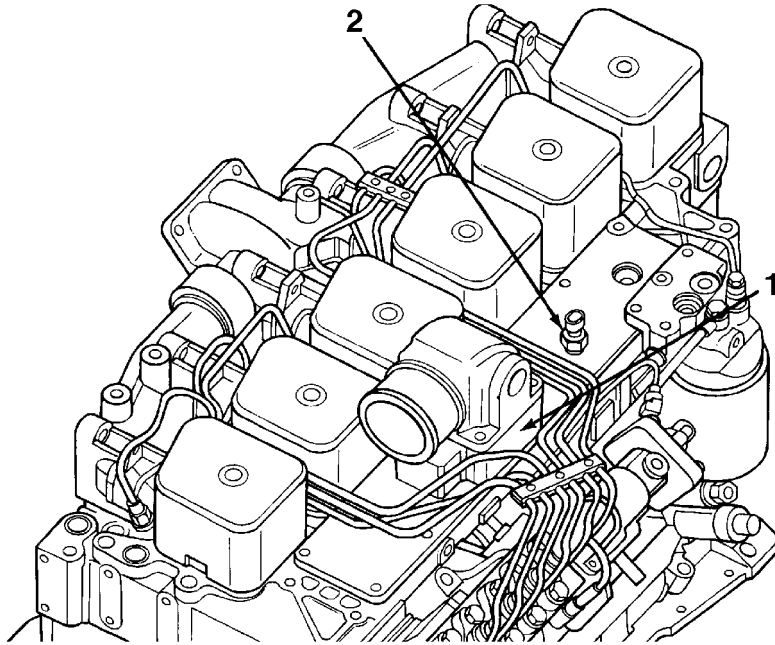

10900271

### Cold Starting System

1. Grid heater
2. Air intake temperature sensor

The following illustration shows grid heater components.

#### Grid Heater Component Connections

1. Ground connection
2. To WAIT-TO-START lamp(s) (dash mounted)
3. Ground connection
4. To fuse and battery
5. Ground connection

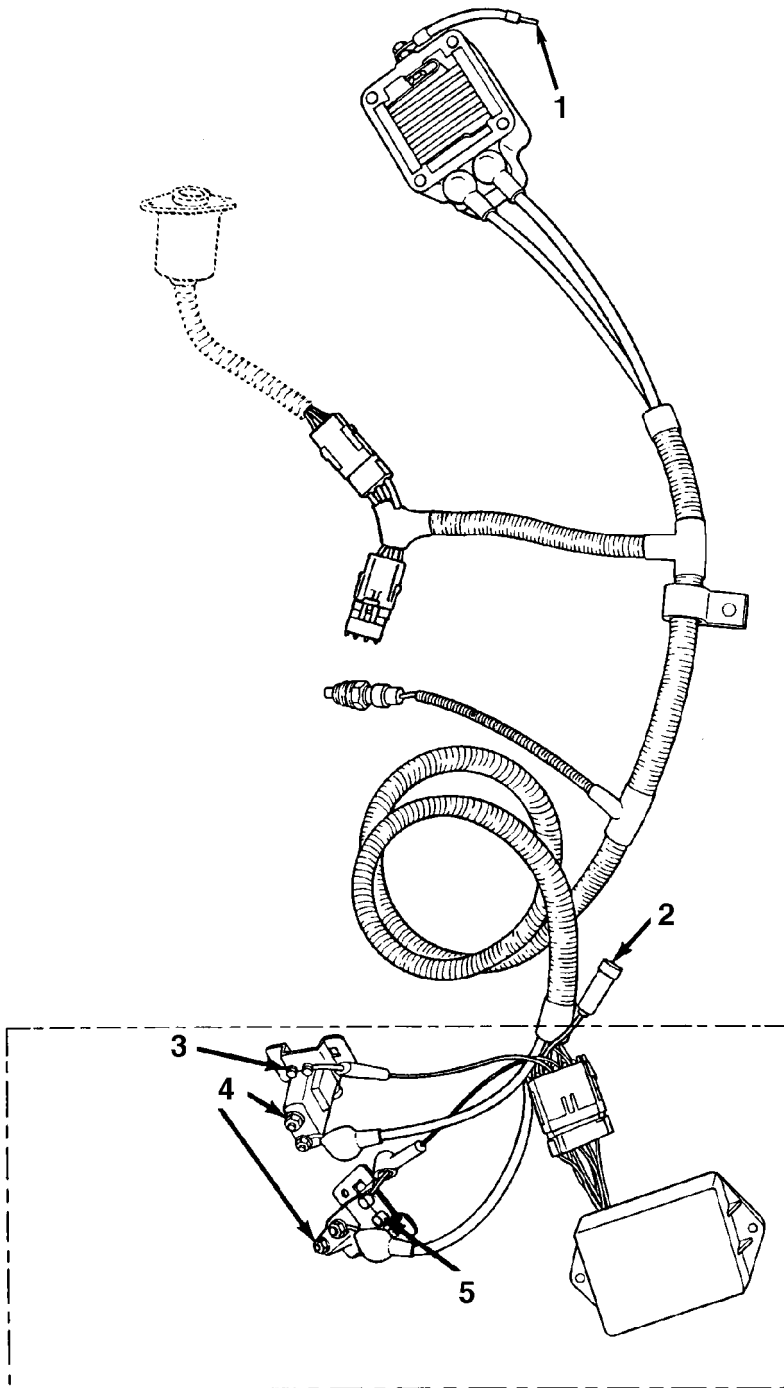

10900272

<b>Troubleshooting for Heater System</b>	
Wait-to-Start (WTS) Lamp <b>Not</b> Functioning	Check wiring, socket, bulb, ground signal from controller, and bulb power supply from the keyswitch. Correct any electrical problems with the WTS lamp. WTS lamp will flash one time a second if an open circuit is detected in the temperature sensor.
Temperature Sensor Failed	Check resistance across the temperature sensor pins J1A and J1B at room temperature and in an ice bath 0°C [32°F]. The resistance should be approximately 800 ohms at room temperature and 2000 ohms for the ice bath. Check the resistance to ground (-) for an open circuit.
	<b>NOTE:</b> Make resistance checks with the keyswitch in the ON position to make sure there are no ground (-) problems.
	Replace defective sensor.
Relay or Contactor Failure	Check relays or contactors for an audible click during operation. Check for pitting or burning in the relay by measuring resistance across the high-amperage terminals when relay is closed. Replace relay(s) if the resistance is high or an audible click is <b>not</b> heard when it is acutuated.
Insufficient Ground (-) Connections	Check pin J1B for ground to the controller. Check the ground (-) strap to the grid heater for high resistance. Repair or replace wiring.
Controller Malfunctioning	Check pin J2A for 12-VDC signal; inspect the wiring harness for shorting, chafing, or burning. The controller operates between 6.5 VDC and 16 VDC. Check the connectors for good connections. Replace the controller, if necessary.
	<b>NOTE:</b> The controller will abort postheat if it senses a voltage drop below 9.5 VDC during preheat or a 10-second delay or more between WAIT-TO-START (WTS) lamp off and cranking, or an open temperature circuit.



**6B Industrial Grid Heater**

The air intake manifold heater is preferred starting aid option in production on all 185- and 200-hp ratings and optional on all other water jacket aftercooled (WJAC) engines with Bosch® in-line injection pumps. For engines **not** equipped with the air intake manifold heater option, a spacer block will be installed instead of an intake heater.

The intake heater improves cold weather starting characteristics by heating the intake air during cranking. It can also serve to reduce white smoke if it is energized during cold ambient temperatures while the engine is at idle. The intake heaters are available for both 12-VDC and 24-VDC systems, and both draw 195 amps while energized.

New hardware has been designed to support the grid heater installation. The engine will have the same overall installation height. The grid heater also has a provision for an air compressor intake line.

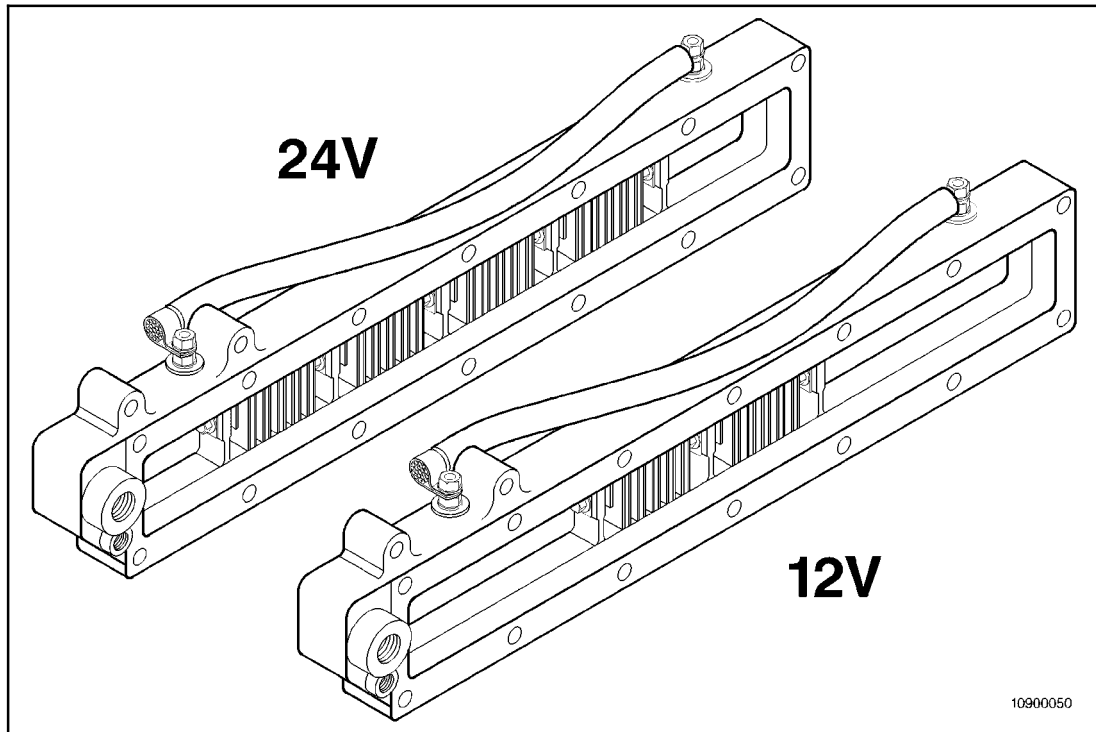

Description	Part No.	Quantity
Grid Heater (12 VDC)	3928465	1
Grid Heater (24 VDC)	3928463	1
Spacer Block	3928464	1
Ground Wire	3928702	1

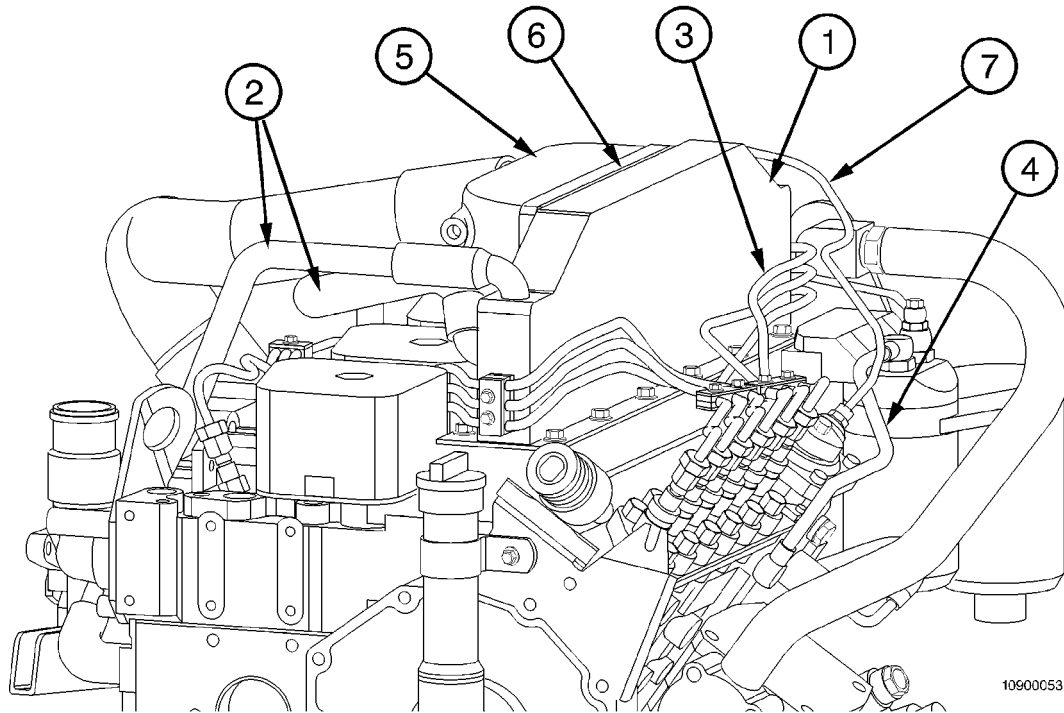

Redesigned hardware installed on the engine to grid heater include:

1. Water jacket aftercooler
2. Water jacket aftercooler plumbing
3. High-pressure fuel lines
4. Low-pressure fuel lines
5. Crossover duct
6. Crossover duct gasket
7. Air-fuel control line.

**NOTE:** This hardware will be installed on all water jacket aftercooled (WJAC) industrial engines with the Bosch® in-line pump. Part numbers will be listed in the 6B industrial engine parts catalog.

**Maintenance Check (010-072-008)**

Check the battery voltage.

Minimum: 6.5 VDC

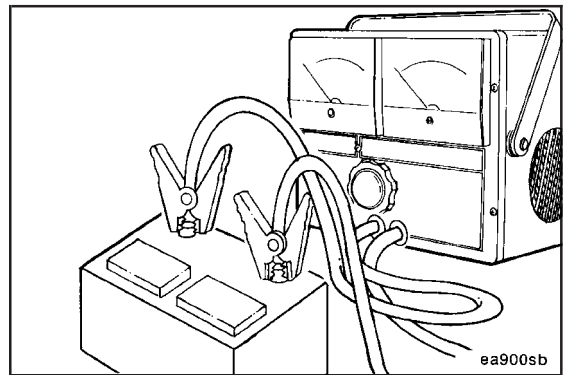

Check the thermistor.

Disconnect the thermistor.

Turn the ignition switch to the ON position.

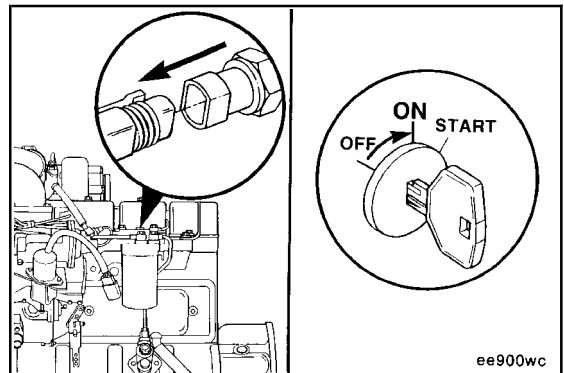

**NOTE:** The WAIT-TO-START light should come on.

The solenoids should click on.

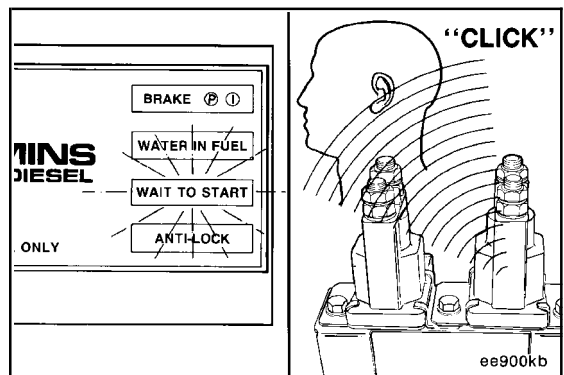

Wait 20 seconds.

The solenoids should click off.

The WAIT-TO-START light should begin flashing.

**NOTE:** The WAIT-TO-START light will flash, indicating an open circuit in the thermistor wiring. Disconnecting the thermistor simulates this condition.

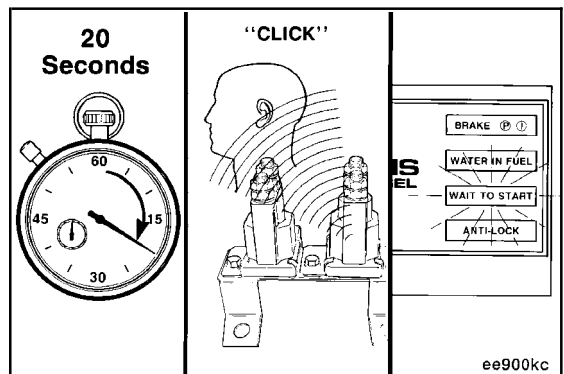

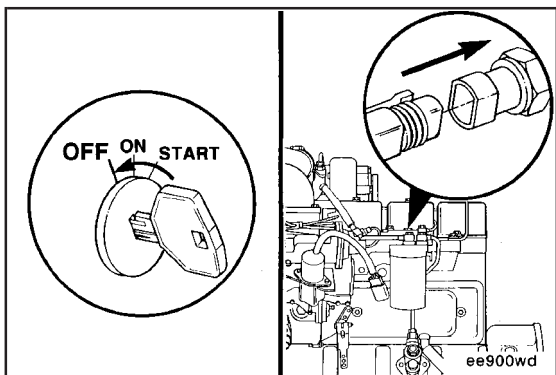

Turn the ignition switch to the OFF position.  
Connect the thermistor wire harness.

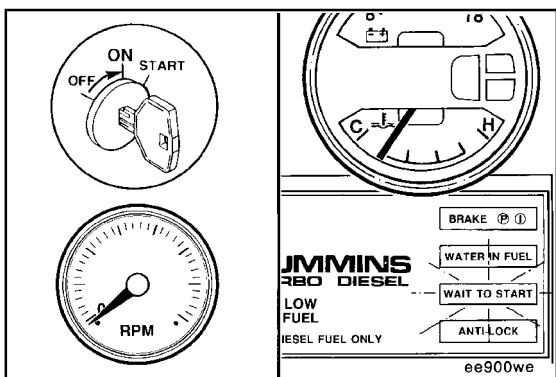

**Preheat Cycle - Check**  
Turn the ignition switch to the ON position.  
Do not start the engine.

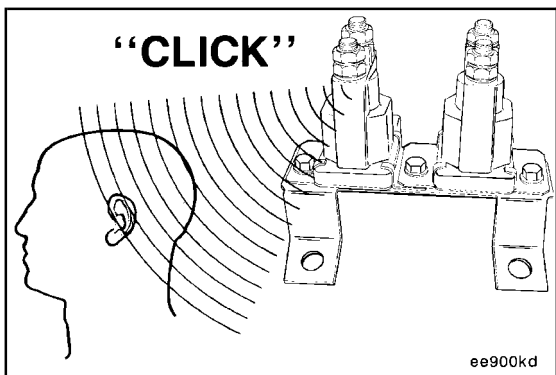

The solenoids should click on.

**NOTE:** If the engine has been running, the temperature is probably above 15°C [59°F].

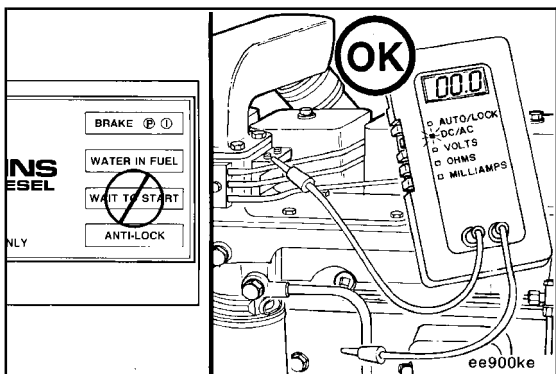

**Digital Multimeter, Part No. 3822666**

After the preheat period, the WAIT-TO-START light will go off and not flash.



Set the multimeter scale to read DC voltage.

Connect the multimeter, Part No. 3822666, lead to the intake manifold heater terminals. Check each terminal individually.

**B3.9 and B5.9 Series Engines  
Section 10 - Air Intake System - Group 10**

If voltage is present, check the pull-in coil of the solenoids.  
Check for voltage at the pull-in coil of solenoid.



1. If voltage at pull-in coil, replace electronic control module.
2. If no voltage present at pull-in, replace solenoid.

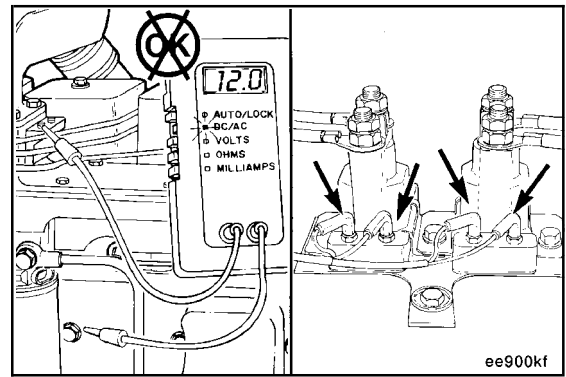

Start the engine.

Do **not** hold the ignition switch in the start position longer than 10 seconds.

If the engine does **not** start, turn the ignition switch to the OFF position.

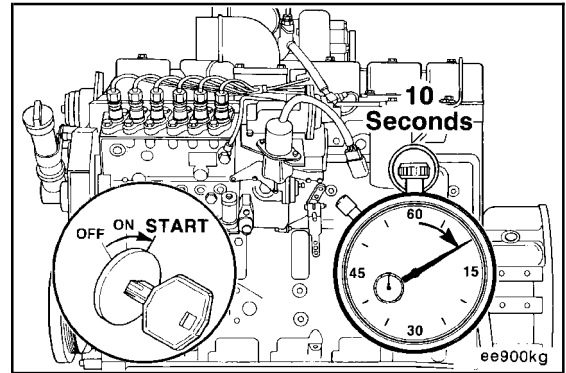

Return the ignition switch to the ON position; then begin the normal starting cycle again.

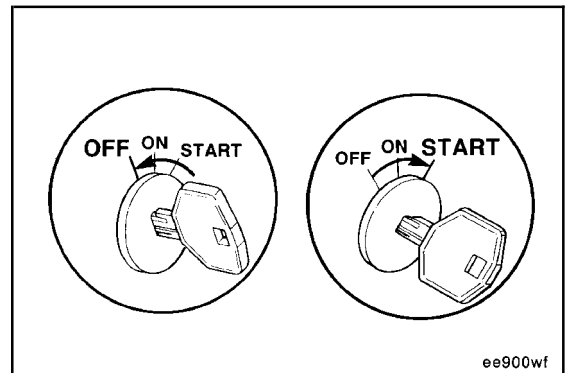

**Remove (010-072-002)**



**Always lock and tag out the ignition system before working on the engine. Disable the preheater electrical system to avoid property damage and personal injury from electrical shock.**

Remove the air intake elbow from the cover.

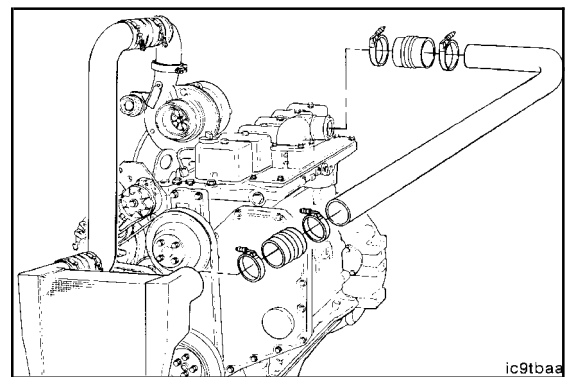

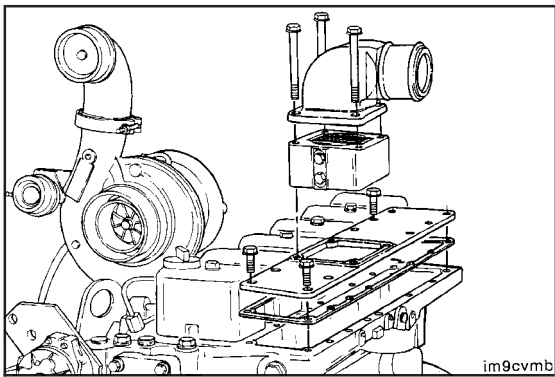

Remove the air intake spacer, Part No. 3917938, from the intake cover and discard. If a manifold spacer is **not** used, replace the elbow with a 3918982 elbow, or equivalent.

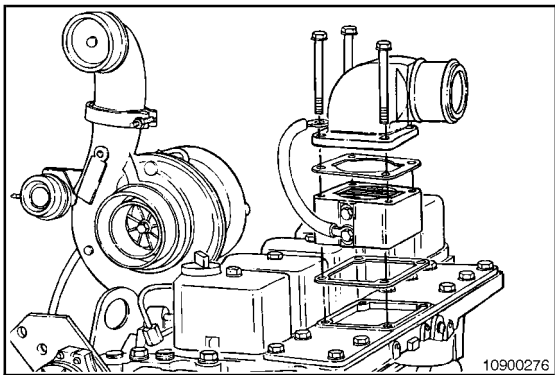

**Install (010-072-026)**

Install the two gaskets, Part No. 3913352, above and below the grid heater, Part No. 3924594, with the ground (-) strap under the grid heater mounting capscrews.



**Torque Value:** 24 N•m [18 ft-lb]

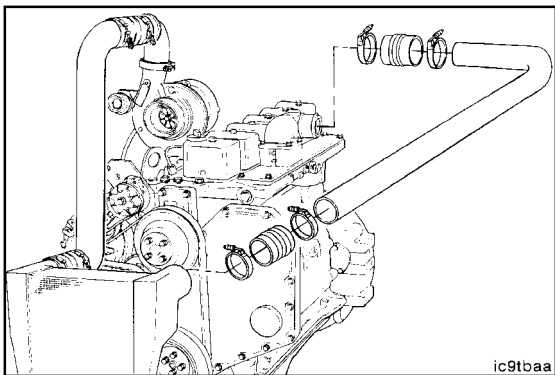

Install the air intake clamps.

**Torque Value:** 8 N•m [71 in-lb]

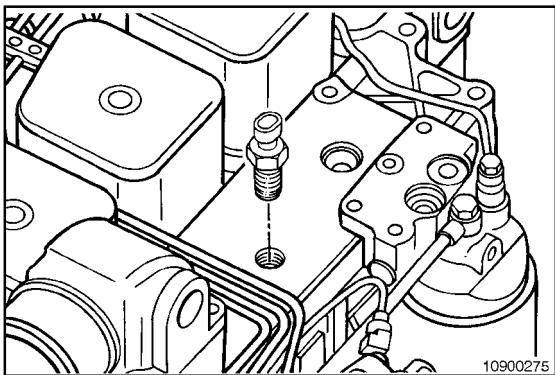

Install the temperature sensor in the intake cover nearest the intake elbow.

**Torque Value:** 35 N•m [26 ft-lb]



**B3.9 and B5.9 Series Engines  
Section 10 - Air Intake System - Group 10**

**NOTE:** The wiring harness should be secured within 152 mm [6 in] of any connection to avoid connector or ring terminal damage.

Install the wiring harness, and secure to avoid chafing or burning.

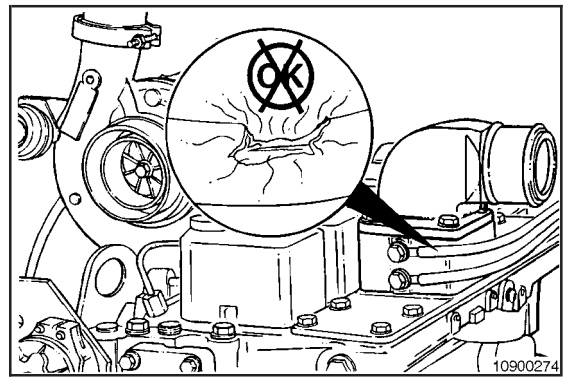

If the engine does **not** have an electrical shutdown solenoid or it has a timer module for the shutdown solenoid, use the 3-pin connector tee to wire the vehicle as illustrated. Refer to the table below.



Connector Letter	Function	Recommended Location
A	Module Power	Keyswitch ON power supply
B	Crank Sensor	“S” Terminal on starter or keyswitch “Crank”
C	Ground (-)	Engine, Chassis, or Battery Ground (-)

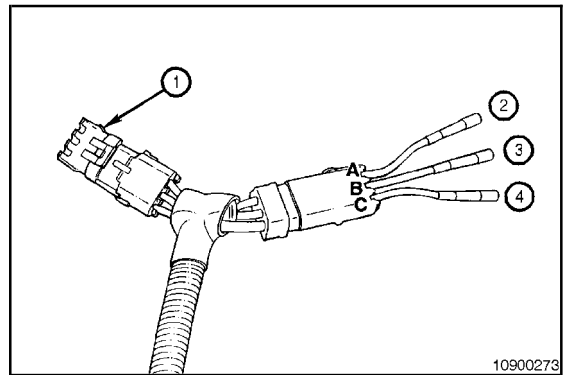





# Section 11 - Exhaust System - Group 11

## Section Contents

	<b>Page</b>
<b>Exhaust Manifold, Dry</b> .....	11-7
Clean .....	11-7
General Information .....	11-7
Inspect for Reuse .....	11-8
Install .....	11-8
Preparatory .....	11-7
Remove .....	11-7
<b>Exhaust Restriction</b> .....	11-9
Measure .....	11-9
<b>Flow Diagram, Exhaust System</b> .....	11-2
<b>Service Tools</b> .....	11-1
Exhaust System .....	11-1
<b>Specifications</b> .....	11-5
Exhaust System .....	11-5

**THIS PAGE LEFT INTENTIONALLY BLANK**

## Service Tools Exhaust System

The following special tools are recommended to perform procedures in this section. The use of these tools is shown in the appropriate procedure. These tools can be purchased from your local Cummins Authorized Repair Location.

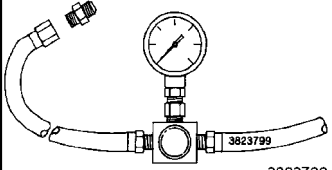
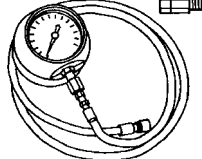
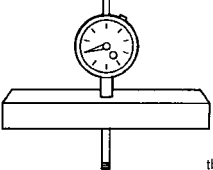
Tool No.	Tool Description	Tool Illustration
3823799	<b>Turbocharger Wastegate Pressure Setting Kit</b> Used to set wastegate pressure.	 <p style="text-align: right;">3823799</p>
ST1273	<b>Pressure Gauge [0 to 75 in Hg]</b> Used to measure the intake manifold pressure or exhaust back pressure.	 <p style="text-align: right;">eg8togi</p>
ST537	<b>Dial Depth Gauge</b> Used to measure turbocharger axial motion.	 <p style="text-align: right;">tb8togf</p>

### Flow Diagram, Exhaust System

**Insert Color File**  
11900052.CDR  
Pantone 165 (Orange)

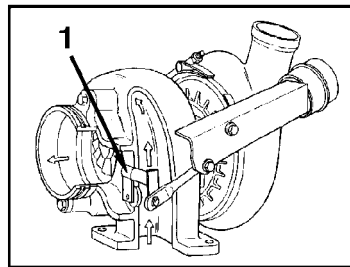
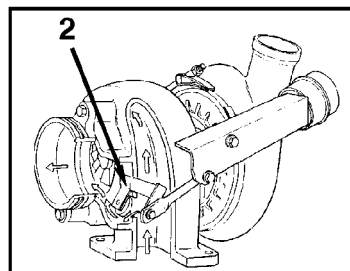
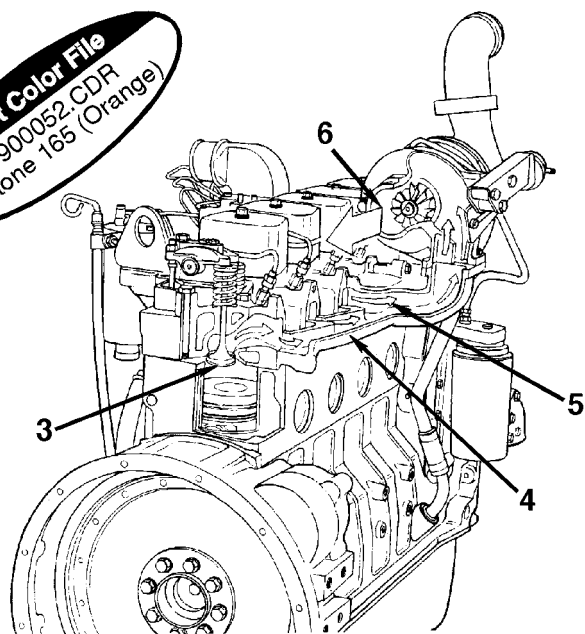

11900052

#### Turbocharged with Wastegate

- 1. Wastegate Closed
- 2. Wastegate Open
- 3. Exhaust Valve
- 4. Exhaust Manifold
- 5. Turbocharger Exhaust Inlet
- 6. Turbocharger Exhaust Outlet.

**Insert Color File**  
11900053.CDR  
Pantone 165 (Orange)

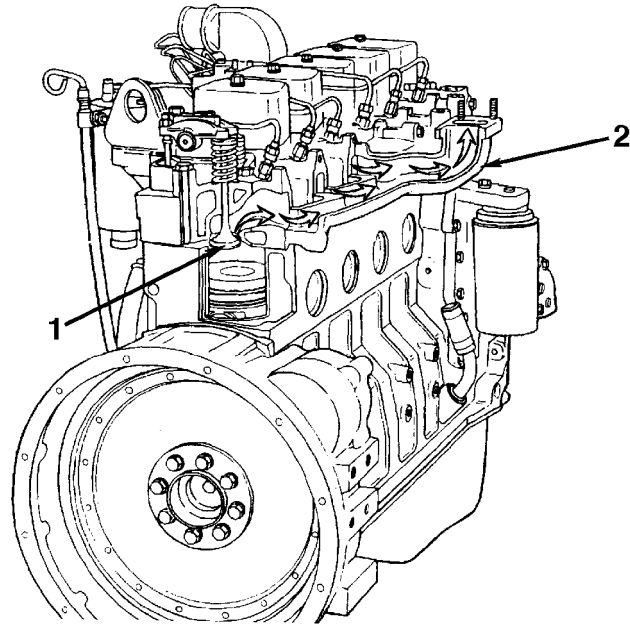

11900053

**Naturally Aspirated Engine**

1. Exhaust Valve
2. Exhaust Manifold.

**Insert Color File**  
11900054.CDR  
Pantone 165 (Orange)

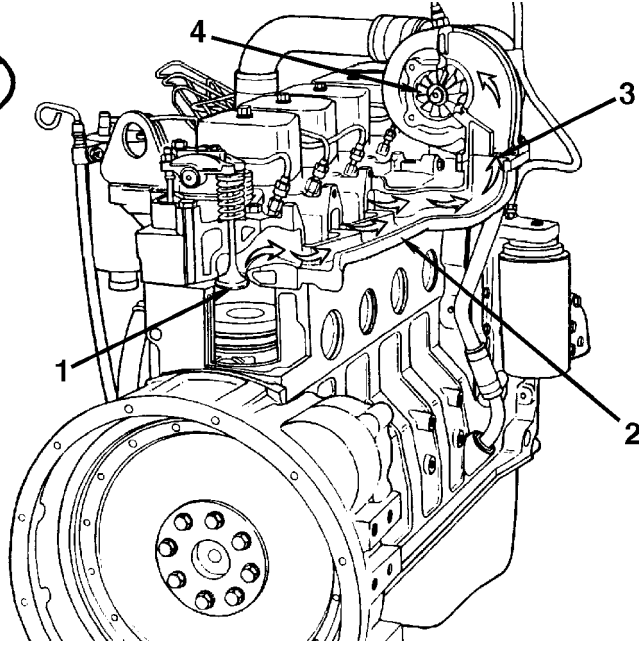

11900054

**Turbocharged Engine**

1. Exhaust Valve
2. Exhaust Manifold
3. Turbocharger Exhaust Inlet
4. Turbocharger Exhaust Outlet.

## Specifications

### Exhaust System

#### Exhaust System Data (automotive)

	B3.9	B5.9
Maximum Allowable Exhaust Restriction at Rated Speed and Loaded (1991 EPA certified)	114.3 mm Hg [4.5 in Hg]	114.3 mm Hg [4.5 in Hg]
Maximum Allowable Exhaust Restriction at Rated Speed and Loaded (1994 EPA certified)	152.4 mm Hg [6 in Hg] with oxidation catalyst	152.4 mm Hg [6 in Hg] with oxidation catalyst

**4B Exhaust System Data (nonautomotive)**

<b>EXHAUST SYSTEM</b>	<b>4B3.9</b>	<b>4BT3.9</b>	<b>4BTA3.9</b>
Maximum Allowable Exhaust Restriction at Rated Speed and Loaded	76.2 mm Hg [3.0 in Hg]	76.2 mm Hg [3.0 in Hg]	76.2 mm Hg [3.0 in Hg]

**6B Exhaust System Data (nonautomotive)**

<b>EXHAUST SYSTEM</b>	<b>6B5.9</b>	<b>6BT5.9</b>	<b>6BTA5.9</b>
Maximum Allowable Exhaust Restriction at Rated Speed and Loaded	76.2 mm Hg [3.0 in Hg]	76.2 mm Hg [3.0 in Hg]	76.2 mm Hg [3.0 in Hg]



## Exhaust Manifold, Dry (011-007)

### General Information

Inspect for exhaust leaks at the exhaust manifold turbocharger, gasket leaks, or exhaust pipe, muffler or catalyst restrictions. Leaks or restrictions will cause turbine and impeller to operate at a lower speed and reduce the amount of air being forced into the cylinder. Again, the symptom will be excessive smoke, low manifold pressure, and low power.

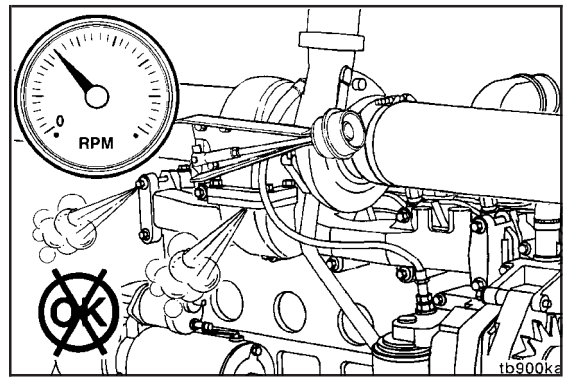

### Preparatory (011-007-000)

- Remove the air crossover tube, if used.
- Disconnect the charge air cooler hose (automotive engines **only**).
- Disconnect the air intake and exhaust piping.
- Remove the turbocharger. Refer to Procedure 010-033.

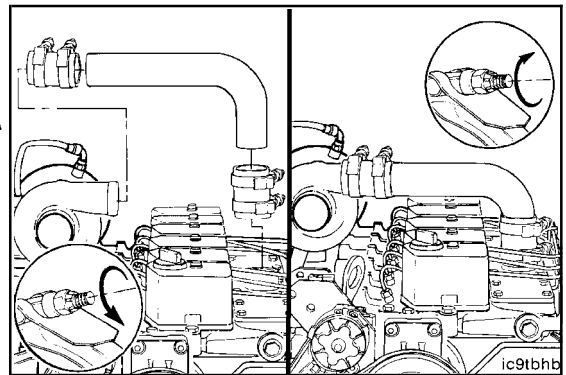

### Remove (011-007-002)

15 mm

Remove the exhaust manifold and gaskets.

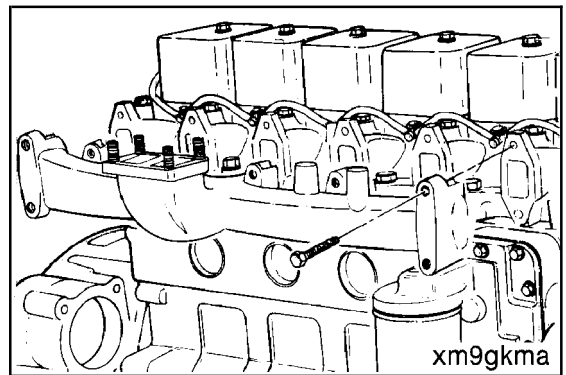

### Clean (011-007-006)

Clean the sealing surfaces.

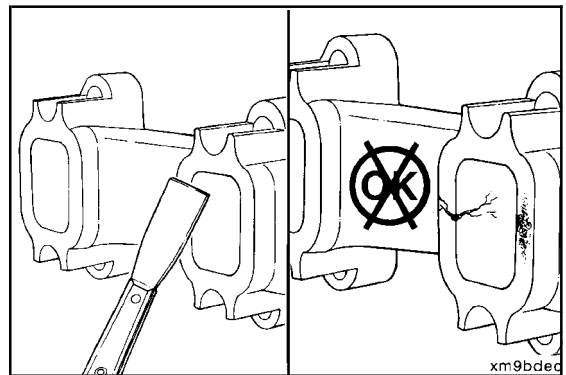

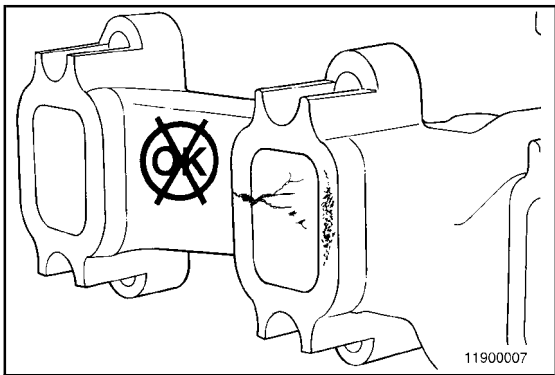

**Inspect for Reuse (011-007-007)**

Inspect the exhaust manifold for cracks, burnout, or damaged threads.

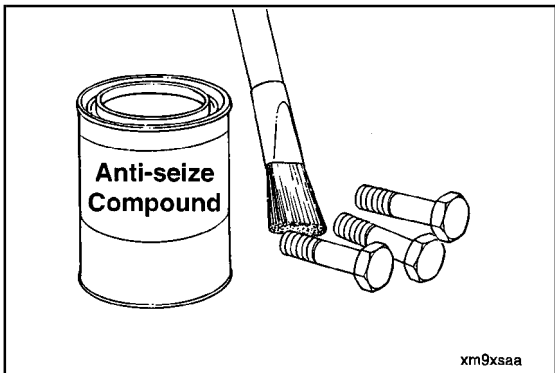

**Install (011-007-026)**

Coat all capscrew threads with an unleaded anti-seize compound.

**NOTE:** Use **only** anti-seize compound compatible with oxygen sensors.

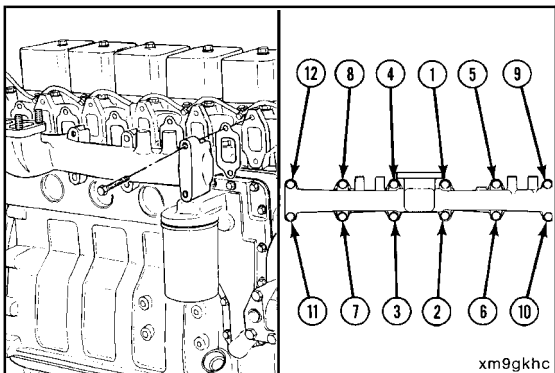

**15 mm**

Install the exhaust manifold and new gaskets.



**Torque Value:** 43 N•m [32 ft-lb]



Follow the tightening sequence shown in the illustration.

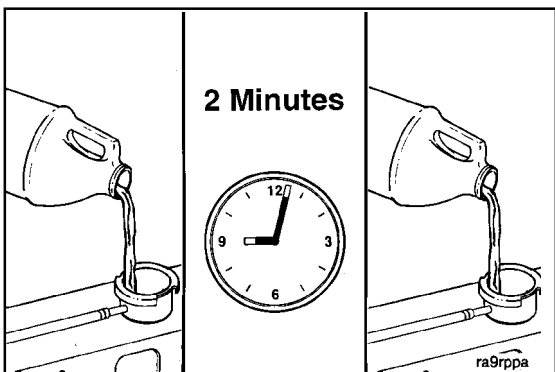

**CAUTION**



The system must be filled slowly to prevent air locks. During filling, air must be vented from the engine coolant passages. The system has a maximum fill rate of 14 liters per minute [3.7 gallons per minute]. Do not exceed this fill rate. Wait 2 to 3 minutes to allow air to be vented. Then add coolant to bring the level to the top.

Install the parts previously removed. Fill the engine with coolant.

Operate the engine, and check for leaks.

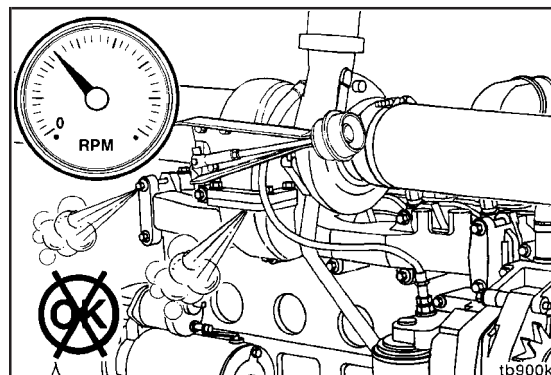

**Exhaust Restriction (011-009)**

**Measure (011-009-010)**

**Pressure Gauge, Part No. ST-1273**

Install pressure gauge, Part No. ST-1273, to the pressure tap in the exhaust head pipe or at the inlet to the catalyst/muffler assembly.

Operate the engine at rated speed and load. Record the exhaust restriction.

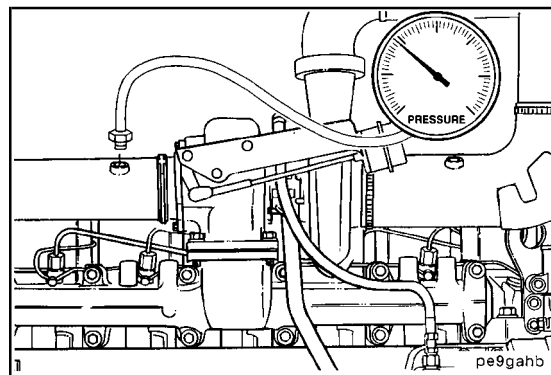

If restriction exceeds specification, inspect the oxidation catalyst and/or muffler and replace according to the vehicle manufacturer's instructions.

	Exhaust Restriction		in Hg
	mm Hg		
Industrial	76	MAX	3
1991 EPA Certification	114	MAX	4.5
1994 EPA Certification with Oxidation Catalyst	152	MAX	6

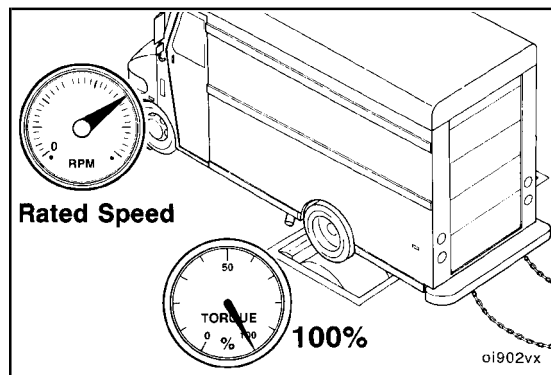



# Section 12 - Compressed Air System - Group 12

## Section Contents

	Page
<b>Air Compressor Carbon Buildup</b> .....	12-9
Initial Check .....	12-9
<b>Air Compressor Coolant Lines</b> .....	12-10
Install.....	12-10
Remove .....	12-10
<b>Air Compressor Cylinder Head (Holset® QE Models)</b> .....	12-35
Assemble.....	12-43
Clean .....	12-40
Disassemble.....	12-37
General Information .....	12-35
Inspect for Reuse .....	12-40
<b>Air Compressor Cylinder Head (Holset® SS191 Model)</b> .....	12-22
Assemble.....	12-30
Clean .....	12-25
Disassemble.....	12-23
Inspect for Reuse .....	12-26
Install .....	12-33
Preparatory.....	12-22
Remove.....	12-22
<b>Air Compressor Pin Bore Wear</b> .....	12-11
Initial Check.....	12-11
<b>Air Compressor Unloader and Valve Assembly</b> .....	12-14
Clean .....	12-15
Initial Check .....	12-14
Inspect for Reuse .....	12-15
Install .....	12-16
Remove.....	12-14
<b>Air Governor (Air Compressor Pumps Continuously)</b> .....	12-19
Test .....	12-19
<b>Air Governor (Air Compressor Will Not Pump)</b> .....	12-18
Test .....	12-18
<b>Air Leaks, Compressed Air System</b> .....	12-21
Leak Test.....	12-21
<b>Compressed Air System - General Information</b> .....	12-3
<b>Flow Diagram, Compressed Air System</b> .....	12-5
<b>Service Tools</b> .....	12-1
Compressed Air System .....	12-1
<b>Specifications</b> .....	12-7
Compressed Air System .....	12-7

**THIS PAGE LEFT INTENTIONALLY BLANK**

## Service Tools Compressed Air System

The following special tools are recommended to perform procedures in this section. The use of these tools is shown in the appropriate procedure. These tools can be purchased from your local Cummins Authorized Repair Location.

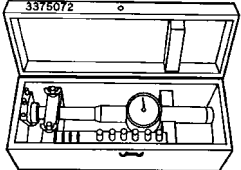
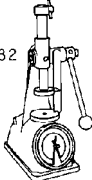
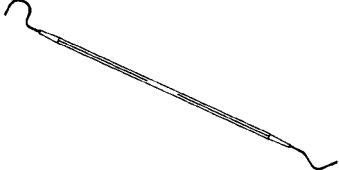
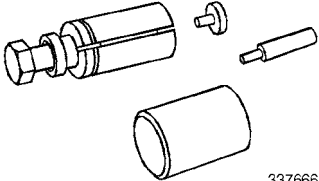
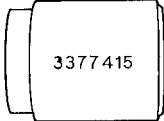
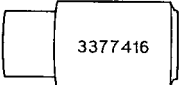
Tool No.	Tool Description	Tool Illustration
3375072	<b>Dial Bore Gauge</b> Used to measure the cylinder bores.	 oi8togu
3375182	<b>Valve Spring Tester</b> Used to check spring tension.	 3375182
3376399	<b>O-ring Pick</b> Used to remove and install o-rings.	 3376399
3376663	<b>Coupling Puller</b> Used to remove the spline coupling hub.	 3376663
3377415	<b>Air Compressor Seat Installation Tool</b> Used to install the exhaust valve seats.	 3377415
3377416	<b>Air Compressor Seat Removal Tool</b> Used to remove the exhaust valve seats.	 3377415 3377416

Tool No.	Tool Description	Tool Illustration
3823528	<p><b>Air Compressor Seat Socket</b> Used to remove the exhaust valve seat and the inlet valve cage.</p>	<p>3823528</p>
3823597	<p><b>Mounting Plate</b> Used to mount the air compressor to the vise.</p>	
3823923	<p><b>Spacer</b> Used with coupling puller, Cummins Part No. 3376663, to remove the hydraulic pump drive coupling.</p>	<p>3823923</p>
3824591	<p><b>Barring Tool</b> Used to engage the flywheel ring gear to rotate the crankshaft.</p>	<p>3824591</p>
ST-1143	<p><b>Air Compressor Bushing Mandrel</b> Used to remove and install the crankshaft bushing in the crankcase and the support.</p>	<p>ST-1143</p>
ST-302	<p><b>Ball Joint Vise</b> Used to hold the air compressor for disassembly or assembly.</p>	
ST-647	<p><b>Standard Puller</b> Used to pull the drive gear. Use with puller capscrews that have M8 x 1.25-6H threads.</p>	<p>ad8toga</p>
ST-755	<p><b>Piston Ring Compressor</b> Used to compress all piston rings to permit easy installation of piston and rod assemblies.</p>	<p>ST-755</p>



## Compressed Air System - General Information

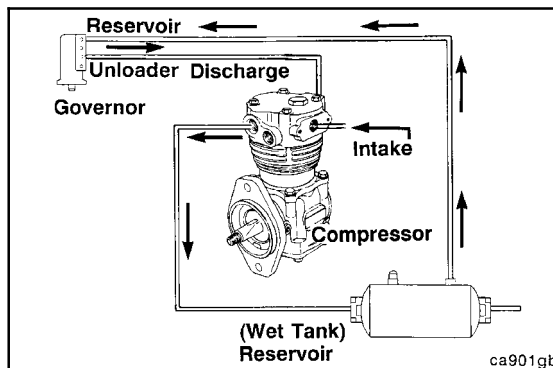

### ⚠ CAUTION ⚠

Vehicles equipped with air dryers vented to atmosphere during unloaded compressor operation, using the Holset® (E-type) air compressor, require the installation of an Econ valve to prevent excessive oil consumption.

The compressed air system normally consists of a gear-driven air compressor, an air governor, air tanks, and all necessary plumbing.

The Holset® SS191B air compressor is an engine-driven, piston-type compressor that supplies compressed air to operate air-activated devices. The compressor operates continuously but has a “loaded” and “unloaded” operating mode. The operating mode is controlled by a pressure activated governor and the compressor unloading assembly. When the air system reaches a predetermined pressure, the governor applies an air signal to the air compressor unloader assembly, causing the unloader valve to hold the compressor intake valve open and compressed air to stop flowing into the air system. As the air in the air system is used, the pressure drops. At a predetermined pressure, the governor exhausts the air signal to the compressor unloader assembly, allowing the compressor to again pump compressed air into the air system.

This air compressor is available in an air cooled or water cooled version, the **only** difference being changes to the cylinder head to incorporate a water passage.

This air compressor is also available with or without a power steering pump housing.

Other brands of compressors can be used on the B Series engine. Troubleshooting procedures are very similar for these air compressors compared to the Holset® SS191. Refer to the specific air compressor manufacturer’s manual for detailed repair information, including torque values.

**NOTE:** The cylinder head and unloader components of the Holset® SS191 air compressor can be serviced without removal of the air compressor on many engine applications. This troubleshooting manual will cover servicing of the air compressor unloader components while the compressor is still on the engine. All other servicing of the air compressor internal components should be done after the compressor has been removed from the engine. Reference the Shop Manual, Bulletin No. 3810433, for detailed disassembly and assembly information on air compressor SS191.

The Holset® SS296 single-cylinder air compressor is an engine-driven, piston-type compressor that supplies compressed air to operate air-activated devices. The compressor runs continuously but has a loaded and unloaded operating mode. The operating mode is controlled by a pressure-activated governor and the compressor unloading assembly.

The SS296 air compressor used on B Series engines uses an (E-type) unloader. The economy (E-type) unloader system was designed to reduce pumping losses and engine boost pressure losses through the compressor intake valve while operating in unloaded mode.

When the air system reaches a predetermined pressure, the governor applies an air signal to the air compressor unloader assembly, causing the unloader cap to seal off incoming air at the intake valve and compressed air to stop flowing into the air system.

**NOTE:** System pressure **must** be maintained on the outlet side of the discharge valve to keep the discharge valve closed.

As the air in the air system is used, the pressure drops. At a predetermined pressure, the governor exhausts the air signal to the compressor unloader assembly, allowing the compressor to again pump compressed air into the air system.

If the air system pressure is **not** maintained on the discharge valve during unloaded operation, air will be pumped out of the compressor cylinder, causing a low-pressure (vacuum) condition to form in the cylinder. With the intake valve sealed off by the unloader cap and the exhaust valve being a one-way pressure actuated valve, no air will be allowed to enter the cylinder. When the compressor cylinder pressure falls below crankcase pressure, oil will be drawn past the piston rings and pumped into the air system.

Other brands of compressors can be used on B Series engines. Troubleshooting procedures are very similar for these air compressors compared to the Holset® SS296. Refer to the specific air compressor manufacturer's manual for detailed repair information and torque specifications.

### Flow Diagram, Compressed Air System

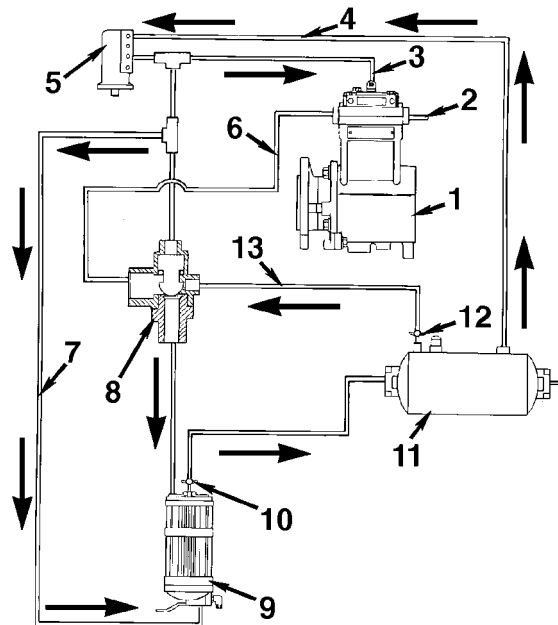

12900074

- |                        |                                    |
|------------------------|------------------------------------|
| 1. Compressor          | 8. Economy valve line              |
| 2. Compressor intake   | 9. Air dryer                       |
| 3. E-Type unloader     | 10. Check valve (built into dryer) |
| 4. Reservoir line      | 11. Reservoir (wet tank)           |
| 5. Governor            | 12. Check valve                    |
| 6. Discharge line      | 13. Secondary pressure line.       |
| 7. Splitter valve line |                                    |



## Specifications

### Compressed Air System

#### A/C Model SS191 Specifications

Compressor Swept Volume at 1250 rpm .....	4.0 L/sec [8.5 SCFM]
Piston Displacement .....	191 cc [11.65 C.I.D.]
Bore .....	80 mm [3.15 in]
Stroke .....	38.1 mm [1.50 in]
Speed .....	1.135 x Engine rpm
Cooling .....	Engine Coolant
Lubrication .....	Engine Lubricating Oil
Plumbing Line Sizes:	
Coolant Inlet and Outlet (pipe fitting) .....	1/2-in NPTF [0.50 in]
Air Inlet (inside diameter) .....	19-mm [0.75-in] Nipple
Air Outlet (minimum inside diameter) .....	1/2-in NPTF [0.50 in]
Height, Overall (approximate) .....	289 mm [11.4 in]
Width, Overall (approximate) .....	125 mm [4.9 in]
Length, Overall (approximate) .....	186 mm [7.32 in]
Weight (approximate) .....	13.6 kg [30 lb]

#### A/C Model QE296 Specifications

Compressor Swept Volume at 1250 rpm .....	6.2 L/sec [13.2 SCFM]
Piston Displacement .....	296 cc [18.06 C.I.D.]
Bore .....	92.08 mm [3.625 in]
Stroke .....	44.45 mm [1.750 in]
Speed .....	1.135 x Engine rpm
Cooling .....	Engine Coolant
Lubrication .....	Engine Lubricating Oil
Plumbing Line Sizes:	
Coolant Inlet and Outlet (pipe fitting) .....	1/2-in NPTF [0.50 in]
Air Inlet (inside diameter) .....	19-mm [0.75-in] Nipple
Air Outlet (minimum inside diameter) .....	1/2-in NPTF [0.50 in]
Height, Overall (approximate) .....	305 mm [12 in]
Width, Overall (approximate) .....	159 mm [6.25 in]
Length, Overall (approximate) .....	267 mm [10.5 in]
Weight (approximate) .....	20 kg [44 lb]

#### A/C Model QE338 Specifications

Compressor Swept Volume at 1250 rpm .....	7.1 L/sec [15 SCFM]
Piston Displacement .....	338 cc [20.6 C.I.D.]
Bore .....	98.43 mm [3.875 in]
Stroke .....	44.45 mm [1.750 in]
Speed .....	1.135 x Engine rpm
Cooling .....	Engine Coolant
Lubrication .....	Engine Lubricating Oil

Plumbing Line Sizes:

Coolant Inlet and Outlet (pipe fitting)	1/2-in NPTF [0.50 in]
Air Inlet (inside diameter)	19-mm [0.75-in] Nipple
Air Outlet (minimum inside diameter)	1/2-in NPTF [0.50 in]

Height, Overall (approximate)	305 mm [12 in]
Width, Overall (approximate)	159 mm [6.25 in]
Length, Overall (approximate)	267 mm [10.5 in]
Weight (approximate)	18 kg [40 lb]

**A/C Model HD650 Specifications**

Compressor Swept Volume at 1250 rpm	6.2 L/sec [13.2 SCFM]
Piston Displacement	296 cc [18.06 C.I.D.]
Bore	92.08 mm [3.625 in]
Stroke	44.45 mm [1.750 in]
Speed	1.135 x Engine rpm
Cooling	Engine Coolant
Lubrication	Engine Lubricating Oil

Plumbing Line Sizes:

Coolant Inlet and Outlet (pipe fitting)	1/2-in NPTF [0.50 in]
Air Inlet (inside diameter)	19-mm [0.75-in] Nipple
Air Outlet (minimum inside diameter)	1/2-in NPTF [0.50 in]

Height, Overall (approximate)	305 mm [12 in]
Width, Overall (approximate)	159 mm [6.25 in]
Length, Overall (approximate)	267 mm [10.5 in]
Weight (approximate)	20 kg [44 lb]

**A/C Model HD850 Specifications**

Compressor Swept Volume at 1250 rpm	7.1 L/sec [15 SCFM]
Piston Displacement	338 cc [20.6 C.I.D.]
Bore	98.43 mm [3.875 in]
Stroke	44.45 mm [1.750 in]
Speed	1.135 x Engine rpm
Cooling	Engine Coolant
Lubrication	Engine Lubricating Oil

Plumbing Line Sizes:

Coolant Inlet and Outlet (pipe fitting)	1/2-in NPTF [0.50 in]
Air Inlet (inside diameter)	19-mm [0.75-in] Nipple
Air Outlet (minimum inside diameter)	1/2-in NPTF [0.50 in]

Height, Overall (approximate)	305 mm [12 in]
Width, Overall (approximate)	159 mm [6.25 in]
Length, Overall (approximate)	267 mm [10.5 in]
Weight (approximate)	18 kg [40 lb]

# Air Compressor Carbon Buildup (012-003)

## Initial Check (012-003-001)

Shut off the engine.

Open the draincock on the wet tank to release compressed air from the system.

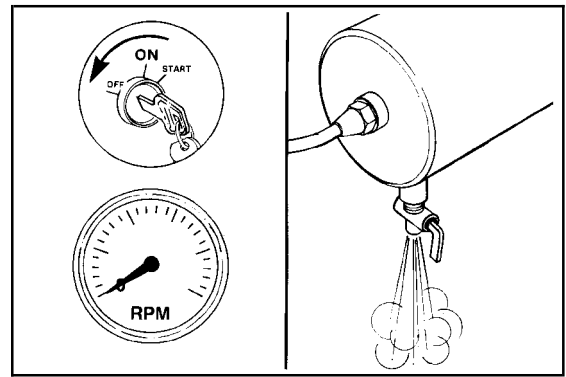

**▲ WARNING ▲**

When using a steam cleaner, wear safety glasses or a face shield, as well as protective clothing. Hot steam can cause serious personal injury.

**▲ WARNING ▲**

Compressed air used for cleaning purposes should not exceed 207 kPa [30 psi]. Wear appropriate eye and face protection when using compressed air. Flying debris and dirt can cause bodily injury.

Use steam to clean the compressor.

Use compressed air to dry.

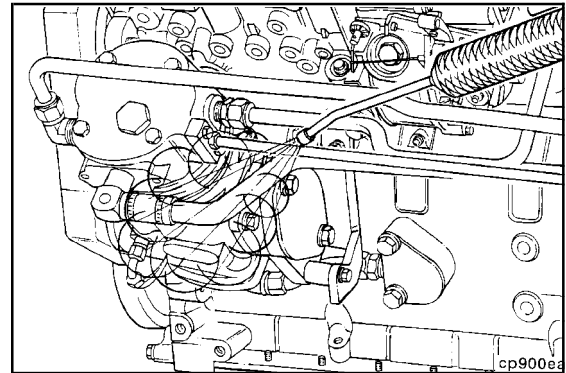

Remove the air inlet and outlet connections from the air compressor.

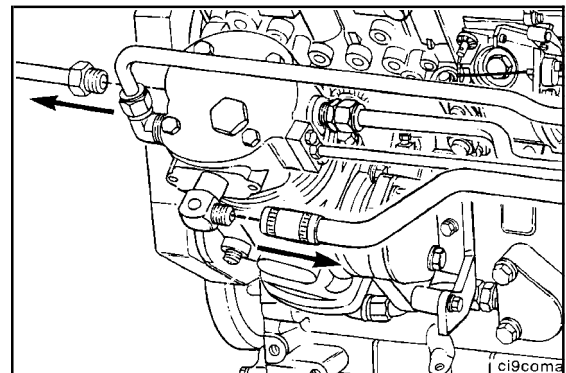

Measure the total carbon deposit thickness inside the air discharge line as shown.

**NOTE:** The carbon deposit thickness **must not** exceed 1.6 mm [0.0630 in].

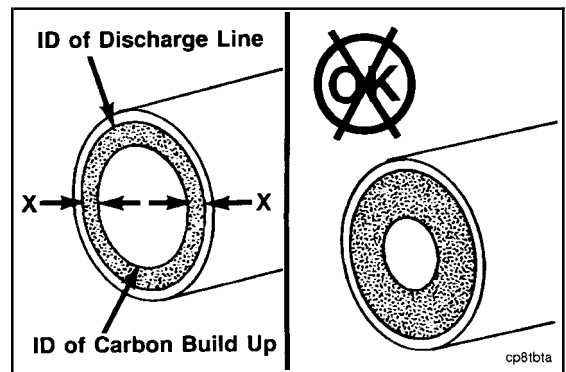

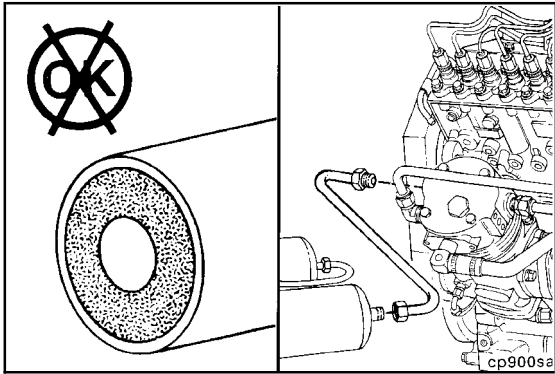

**▲ WARNING ▲**

The air discharge line must be capable of withstanding extreme heat and pressure to prevent personal injury and property damage. Refer to the manufacturer's specifications.



**NOTE:** If the total carbon deposit thickness exceeds specification:



- Remove and clean, or replace, the air discharge line. Refer to manufacturer's material specifications
- Remove and inspect unloader components and cylinder head.

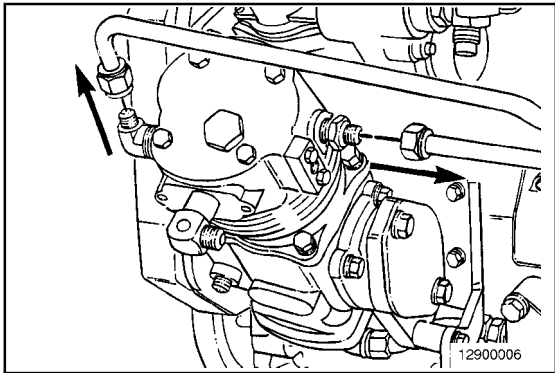

**Air Compressor Coolant Lines (012-004)**

**Remove (012-004-002)**

Remove the coolant lines from the air compressor (does not apply to air cooled compressors).

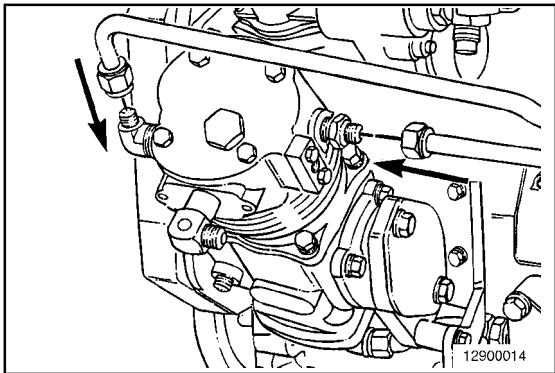

**Install (012-004-026)**

**▲ CAUTION ▲**

If rubber grommets are used on the coolant lines, be sure they are installed carefully to prevent cuts or tears to the grommets which will cause leaks.



Install the coolant lines.

**Torque Value:** 24 N•m [18 ft-lb]



## Air Compressor Pin Bore Wear (012-010)

### Initial Check (012-010-001)



**WARNING**

The unloader valve body is installed with spring tension. Use care when removing to prevent personal injury. Always wear protective eyewear.

**NOTE:** This procedure applies to SS and ST models **only**.

Hold the unloader valve body down, and remove the two captive washer capscrews and the two plain washers.

Remove the unloader valve body.

Remove the o-ring seal.

Remove the rectangular ring seal.

Remove the unloader valve cap and the unloader valve spring.

**NOTE:** Disassembly of the center unloader valve on Holset® two-cylinder air compressors is similar to the single-cylinder unloader valve.

Remove the intake valve seat and valve.

Remove the intake valve spring.

To avoid damage to the air compressor, do **not** allow any debris to fall into the air compressor cylinder.

**NOTE:** Do **not** use a screwdriver. A screwdriver can gouge the top of the piston.

Insert the small end of a 3/8-inch drive socket extension (6 to 10 inches long) through the exhaust valve seat onto the top of the piston.

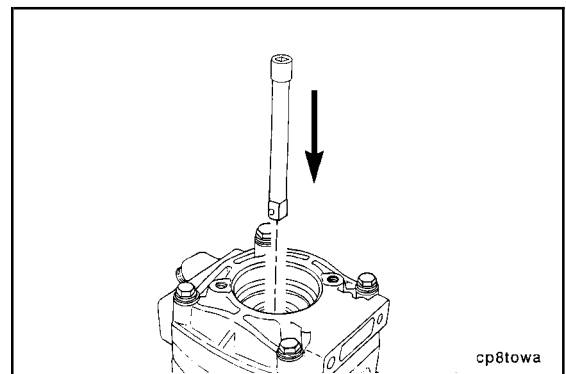
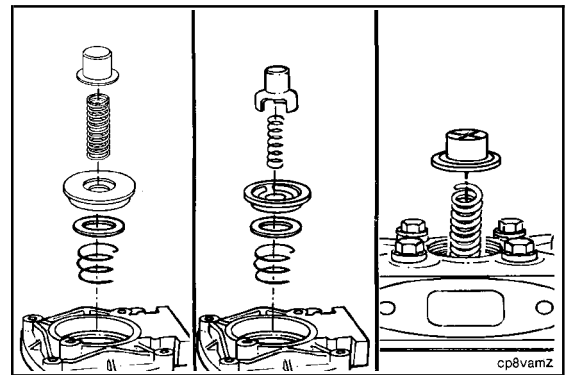
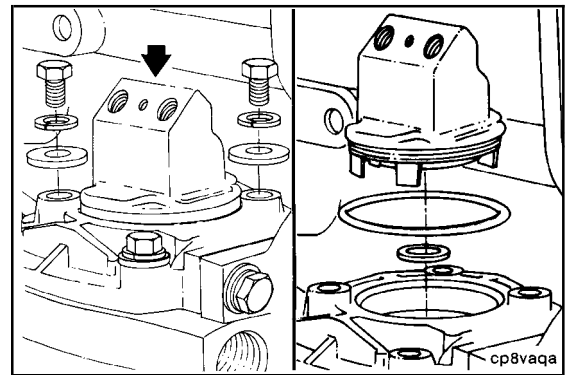

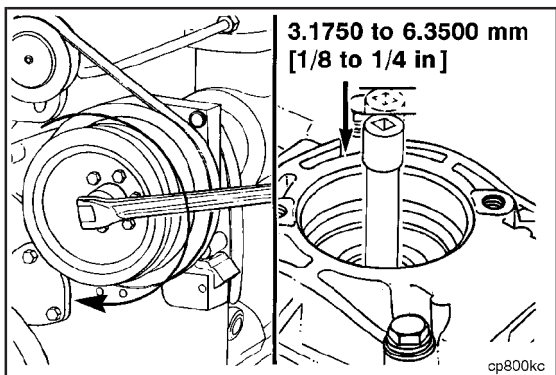

Bar the crankshaft over until the compressor piston reaches top dead center (TDC), and the extension starts to move downward approximately 3 to 6 mm [1/8 to 1/4 in].

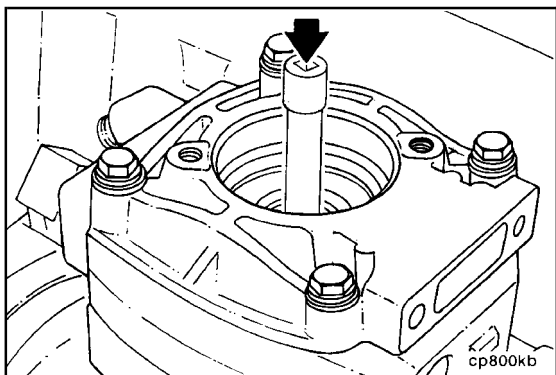

**NOTE:** To prevent damage to the top of the piston, do **not** use a hammer.

Give a quick, hard push downward on the extension and listen for a metallic click as wear clearance is taken up.

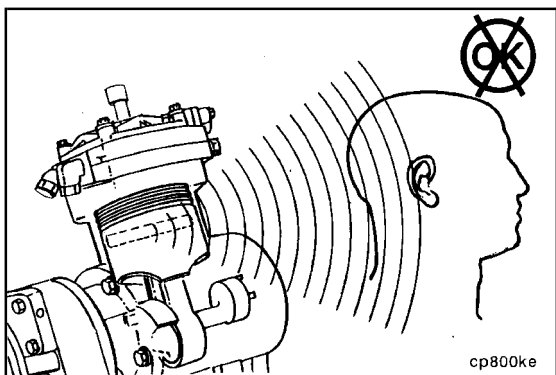

If significant piston motion is felt or a metallic click is heard, the pin bores can be worn, and the compressor **must** be examined further.

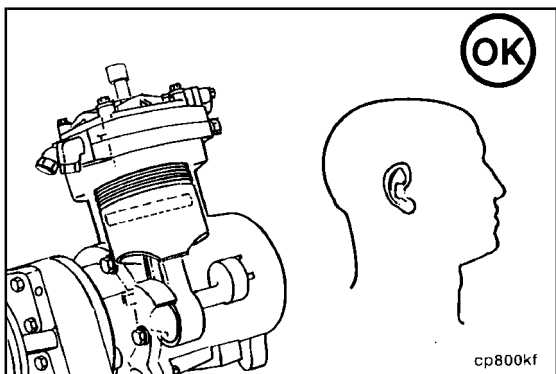

If no motion or sound is heard, the compressor is in satisfactory condition and does **not** need to be replaced.

**NOTE:** **Not** all air compressors will exhibit pin bore wear.

Remove the extension.

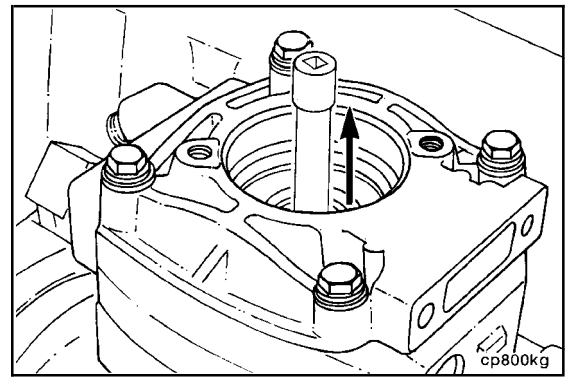

Install the intake valve spring with the tang down.

Install the intake valve.

Install the intake valve seat with the flange side up.

Install the unloader valve cap spring.

Install the unloader valve cap.

Use high-temperature grease (Accrolube lubrication Teflon™ grease, or equivalent) to lubricate the outside diameter of the cap.

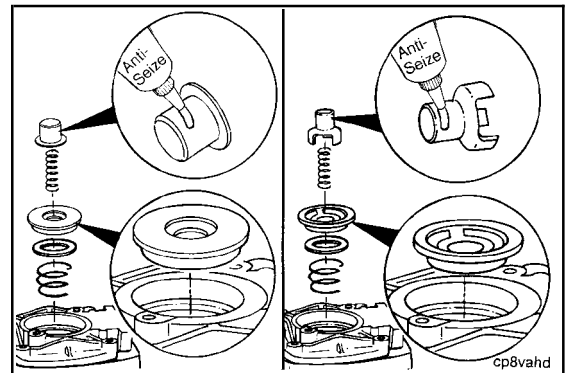

**NOTE:** The rectangular ring seal **must** be installed with the grooved side up.

Install the rectangular ring seal.

Install the o-ring seal.

Use clean engine oil to lubricate the o-ring seal.

Install the unloader valve body.

**NOTE:** Press the unloader valve body down to be sure the tangs of the unloader valve cap are in the three slots of the intake valve seat.

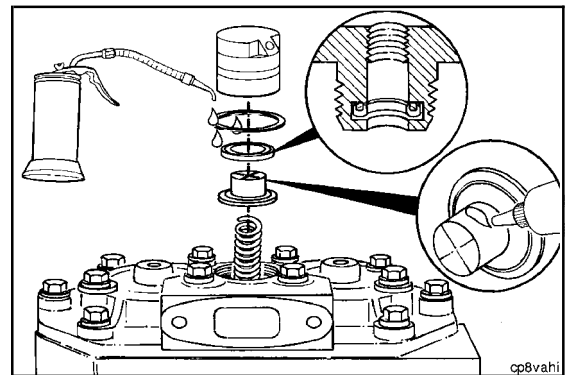

**⚠ CAUTION ⚠**

**Do not overtighten. Failure to do so can cause compressor damage.**

Hold the unloader body down and install the two plain washers and captive washer capscrews.

Tighten the capscrews.

**Torque Value:** 14 N•m [124 in-lb]

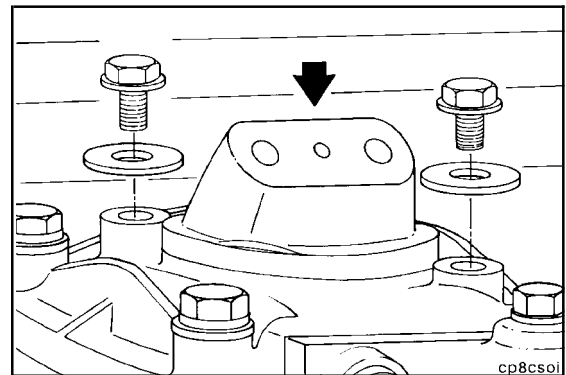

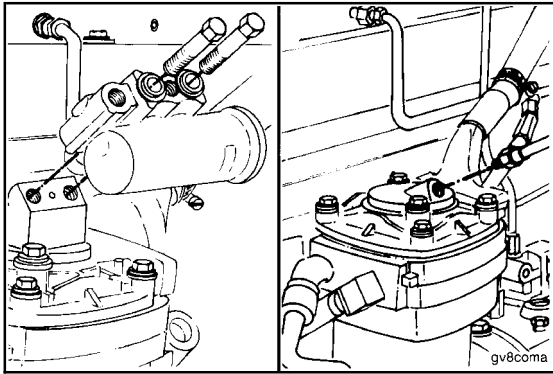

## Air Compressor Unloader and Valve Assembly (012-013)

### Initial Check (012-013-001)



**WARNING**  
Air pressure must be released from the system before removing the air governor. The governor can be under pressure and cause personal injury.

**NOTE:** The illustrations shown will be of the SS model single-cylinder air compressor. Differences in procedures for SS, QE, and ST model Holset® air compressors will be shown where necessary.

Remove the air governor or air governor hose from the air compressor unloader body.

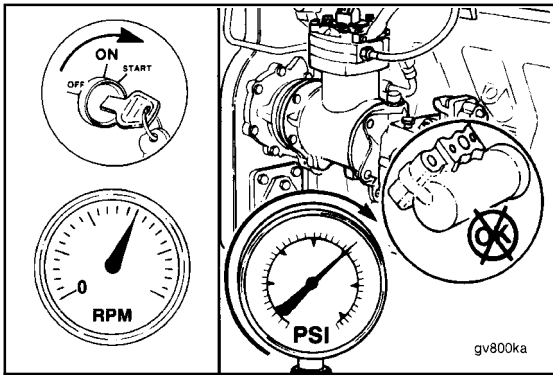

Operate the engine to activate the air compressor.  
If the air compressor is **not** pumping, the unloader valve is malfunctioning, and **must** be repaired or replaced.

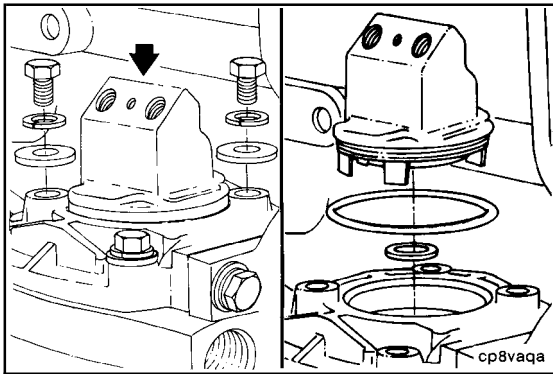

### Remove (012-013-002)



**WARNING**  
The unloader valve body is installed with spring tension. Use care when removing to prevent personal injury. Always wear protective eyewear.

#### Holset® SS, E-Type, and ST Models

Hold the unloader valve body down, and remove the two captive washer capscrews and the two plain washers.

Remove the unloader valve body.

Remove the o-ring seal.

Remove the rectangular ring seal.

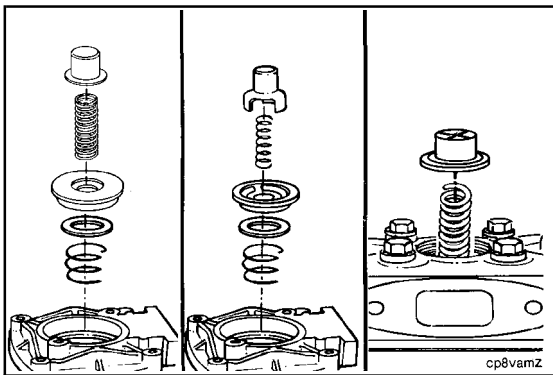

Remove the unloader valve cap and the unloader valve spring.

**NOTE:** Disassembly of the center unloader valve on Holset two-cylinder air compressors is similar to the single-cylinder unloader valve.

Remove the intake valve seat and valve.

Remove the intake valve spring.

**▲ WARNING ▲**

The unloader body is installed with spring tension. Use care when removing to prevent personal injury. Always wear protective eyewear.

**Holset® QE Models**

Hold the unloader valve body down, and remove the four capscrews.

Remove the unloader valve spring.

Remove the unloader valve cap.

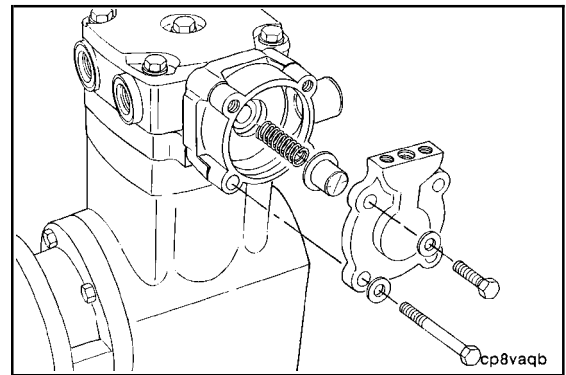

Remove the unloader body gasket and unloader valve cap rectangular ring seal.

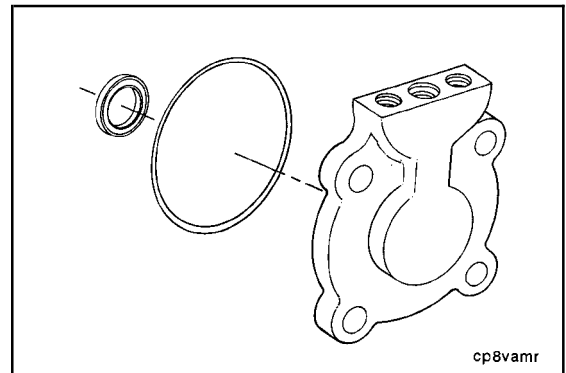

**Clean (012-013-006)**

**▲ CAUTION ▲**

Do not use caustic cleaners. Failure to do so can cause compressor damage.

Remove all carbon and varnish from the unloader valve cap body.

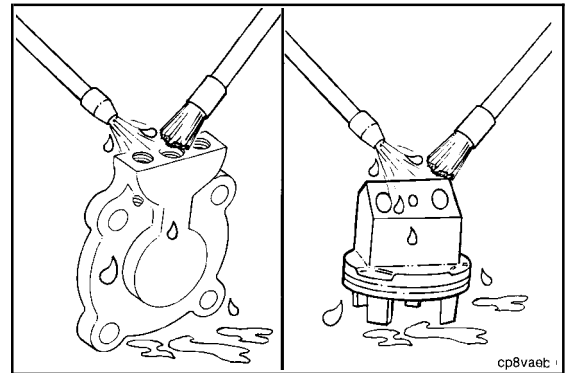

**Inspect for Reuse (012-013-007)**

**Valve Spring Tester, Part No. 3375182**

Use the valve spring tester, Part No. 3375182, to check the unloader spring.

Replace the unloader spring if it does **not** meet the specifications shown, or the wrong spring has been used.

**NOTE:** For Holset® two-cylinder air compressors, check both cylinder and center unloader springs. Holset® recommends that new springs be installed during rebuild.

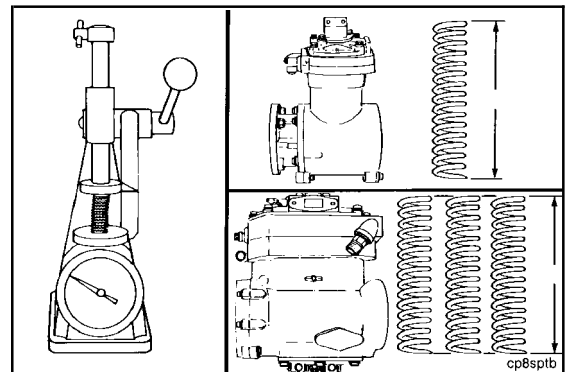

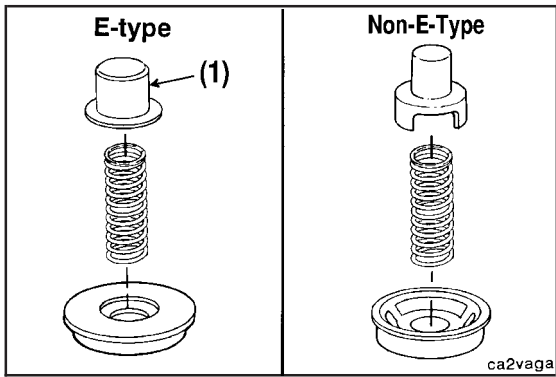

**NOTE:** If the compressor has a flat-hat-type unloader cap (1), it **must** use an unloader spring and valve seat different from that used with the three-prong unloader.

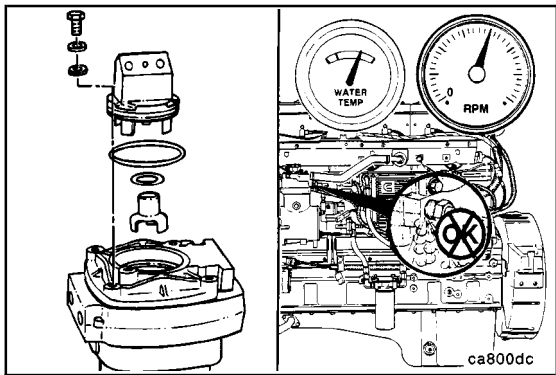

**Install (012-013-026)**

**Holset® SS, E-Type, and ST Models**

Assemble the air compressor.



- Grease rectangular ring seal, unloader cap, and unloader body bore with high-temperature grease (Accrolube lubrication Teflon™ grease, or equivalent).



**Torque Value:** 14 N•m [124 in-lb]



Operate the engine, and check the compressor for air leaks.

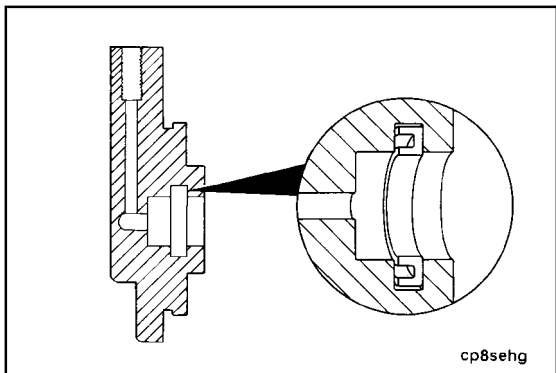

Install the new rectangular V-seal into the unloader body.

**NOTE:** The seal **must** be installed with the grooved side up.



Liberaly lubricate the unloader valve bore above and below the rectangular ring seal with high-temperature grease (Accrolube lubrication Teflon™ grease, or equivalent).

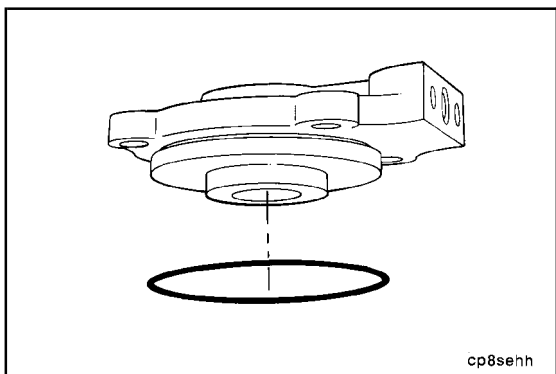

Install a new o-ring seal on the unloader valve body.

Use clean lubricating engine oil or Accrolube lubrication Teflon™ grease, or equivalent, to lubricate the seal.

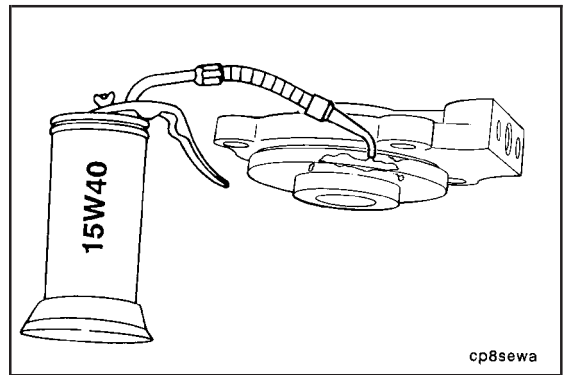

cp8sewa

Liberaly lubricate the unloader valve body bore and unloader cap with high temperature grease (Accrolube lubrication Teflon™ grease, or equivalent).

Install the unloader cap.

Install the unloader spring.

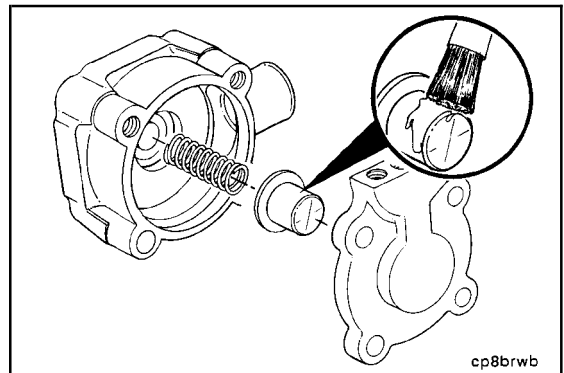

cp8brwb

Lubricate the unloader screw threads and underhead with clean lubricating engine oil before installation.

**NOTE:** The two unloader body screws **must not** be used to attach any brackets.

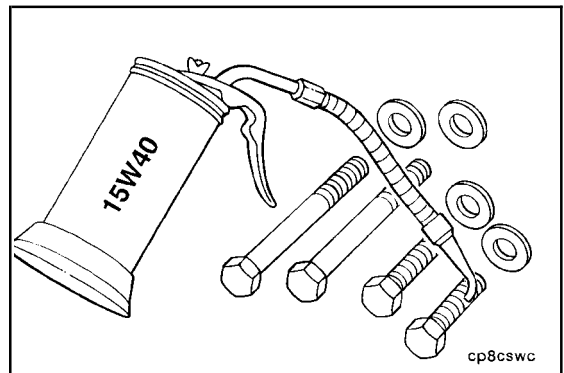

cp8cswc

Assemble the unloader components, and attach the unloader assembly to the valve plate with the four capscrews and washers.

**NOTE:** The longer capscrews are used to mount the manifold to the air compressor.

**Torque Value:** 27 N•m [20 ft-lb]

Operate the engine, and check the air compressor for air leaks.

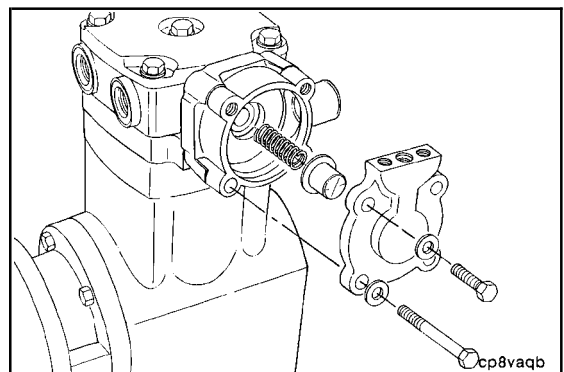

cp8vaqb

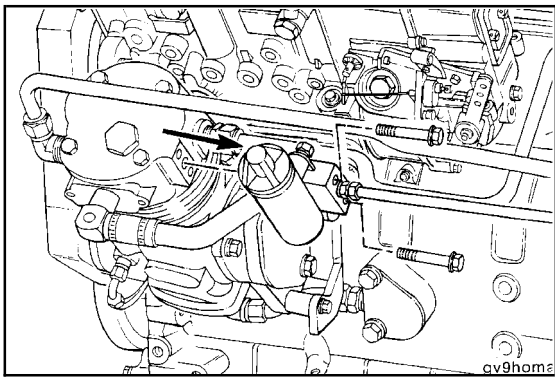

### Air Governor (Air Compressor Will Not Pump) (012-017)

#### Test (012-017-012)

Remove the air governor hose from the air compressor unloader body.

If the air governor is mounted directly on the air compressor, then remove the air governor from the compressor.

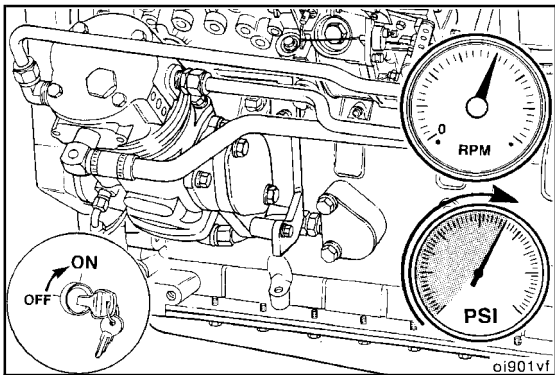

#### CAUTION



During this test, do not exceed maximum vehicle air system pressure or 1035 kPa [150 psi], whichever is lower. Refer to the manufacturer's specifications.

Operate the engine to activate the air compressor.

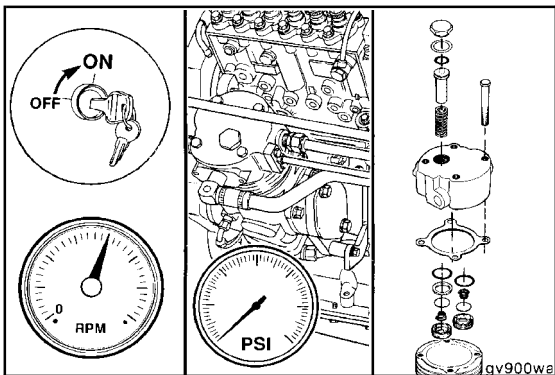

If the air compressor does **not** pump, then the fault is in the air compressor.



Remove and inspect the cylinder head and unloader components. Refer to the Master Repair Manual, Holset® Air Compressors, Bulletin No. 3666121. If no problems are found during disassembly or inspection of the cylinder head or unloader components, then the compressor should be removed and disassembled to determine the cause of the problem.



Refer to Procedure 012-014 and SS191 Single-Cylinder Air Compressor Shop Manual, Bulletin No. 3810433.

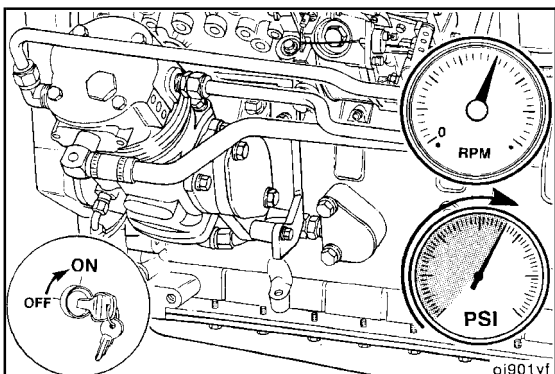

#### CAUTION

During this test, do not exceed maximum vehicle air system pressure or 1035 kPa [150 psi], whichever is lower. Refer to the manufacturer's specifications.

Operate the engine, and check air compressor operation with the air governor removed.



Install the air governor line to the unloader body and tighten.

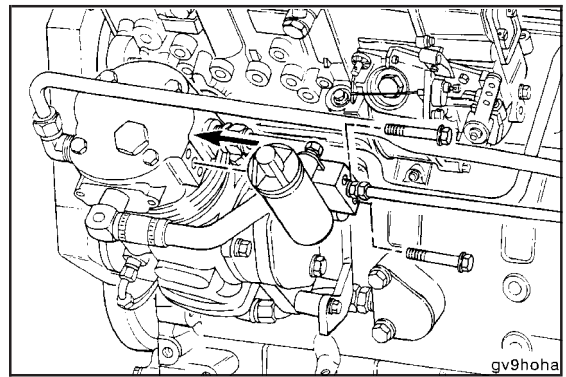

### Air Governor (Air Compressor Pumps Continuously) (012-018)

#### Test (012-018-012)

Remove the accessory air lines from the air governor unloader port.

**NOTE:** Do **not** disconnect the line from the air compressor unloader valve. Do **not** disconnect the reservoir air line from the air governor. If the governor is mounted on the compressor, do **not** remove the governor from the compressor.

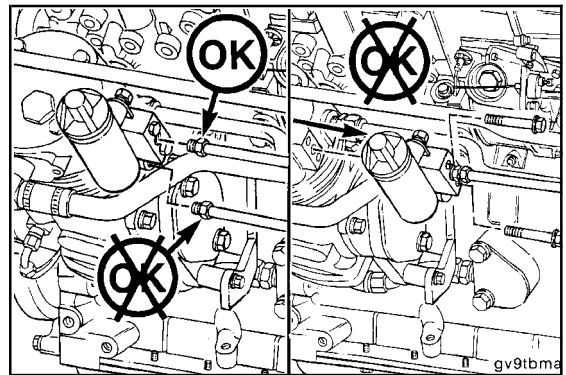

Install pipe plugs in the air governor unloader ports where accessory air lines were removed.

Operate the engine to activate the air compressor.

If the air compressor stops pumping (air pressure stops rising) at the governed air pressure, there is a leak in an accessory or an accessory air line. Refer to the equipment manufacturer's instructions for troubleshooting and repair.

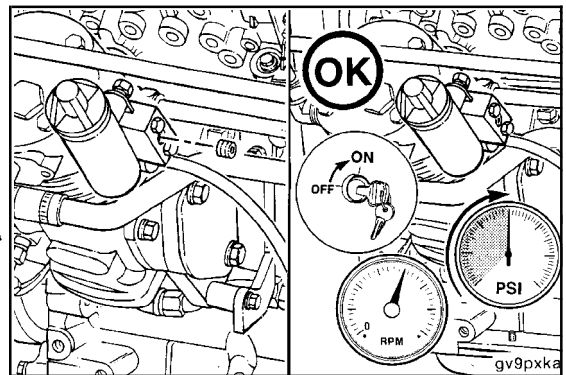

If the air compressor does **not** stop pumping (air pressure continues to rise) at the governed air pressure, connect a regulated shop air pressure line to the air compressor unloader valve port.

**NOTE:** If the governor is mounted on the air compressor, then the governor will have to be removed.

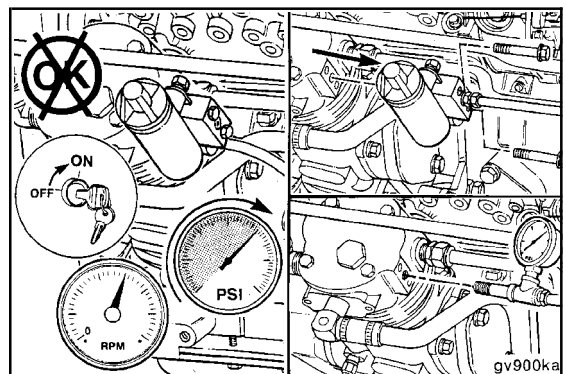

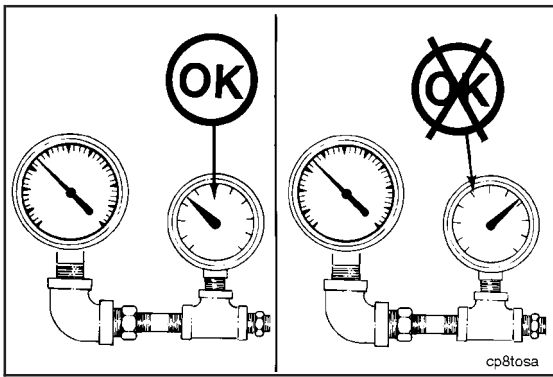

**NOTE:** Be sure the air pressure gauge is accurate and the supply lines and fittings are in good condition before performing any air pressure checks.

Use a master gauge of known accuracy to check the air pressure gauge.

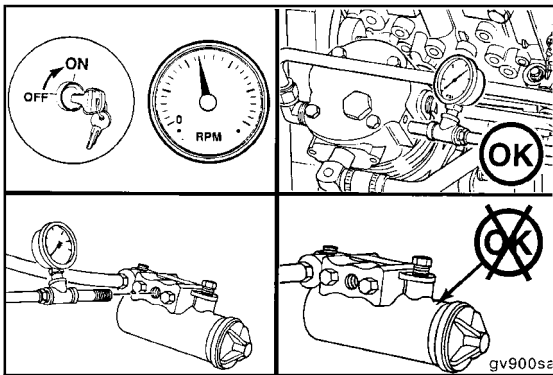

Apply 690 kPa [100 psi] of air pressure to the unloader port.



If the air compressor stops pumping (air pressure stops rising), the air governor is malfunctioning and **must** be repaired or replaced. Refer to the manufacturer's instructions.

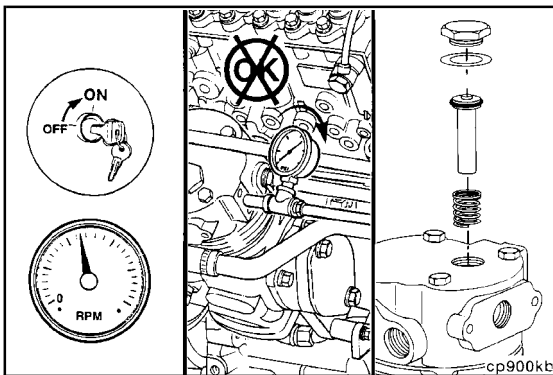

If the air compressor continues to pump (air pressure continues to rise), the unloader valve is malfunctioning and **must** be repaired or replaced. Refer to the Master Repair Manual, Holset® Air Compressors, Bulletin No. 3666121.

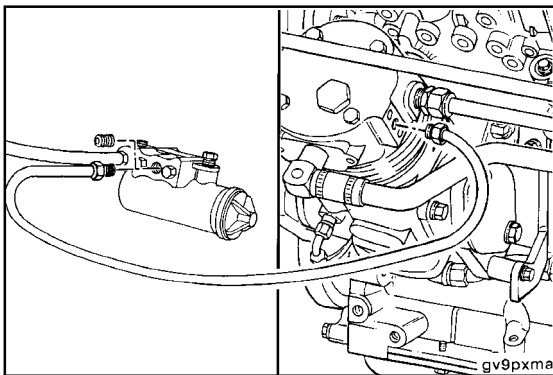

Remove the pipe plugs from the unloader ports used for accessory air lines.



Install and tighten the accessory air lines.

Connect the line to the unloader valve.

Operate the engine, and check for air leaks.

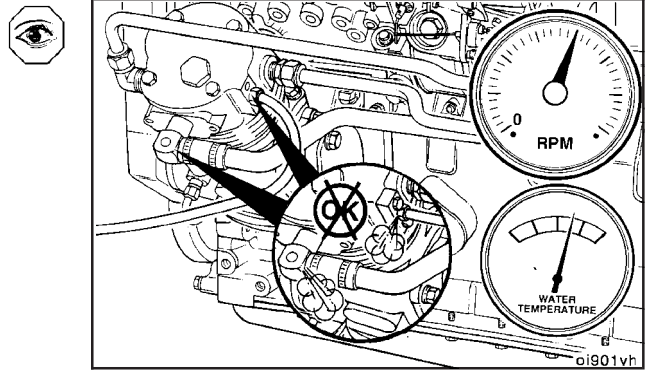

### Air Leaks, Compressed Air System (012-019)

#### Leak Test (012-019-014)

Shut off the engine.

Open the drain cock on the wet tank to release air from the system. Close the draincock after the pressure is released.

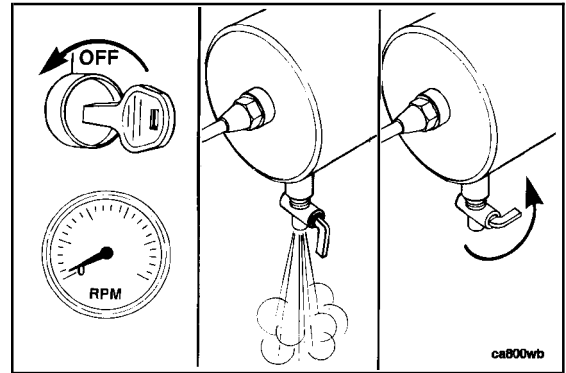

Operate the engine to activate the air compressor.

With the air compressor pumping between 550 to 690 kPa [80 to 100 psi], use a solution of soapy water to check for air leaks in the following areas:

- Unloader cover gasket
- Unloader pin o-ring
- Air compressor head gasket.

If air leaks are found, refer to the Master Repair Manual, Holset® Air Compressors, Bulletin No. 3666121 for repair of these components.

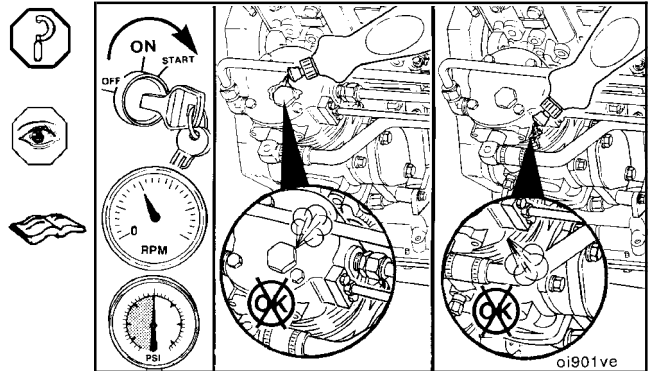

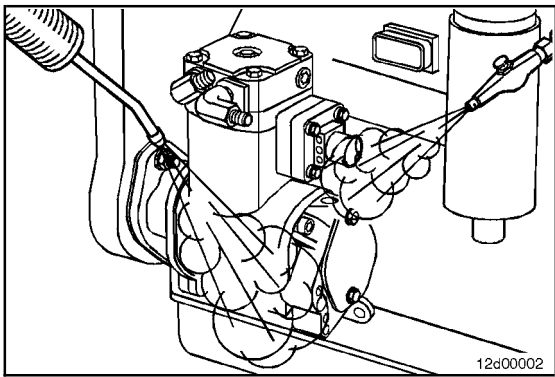

## Air Compressor Cylinder Head (Holset® SS191 Model) (012-101)



### Preparatory (012-101-000)

**▲ WARNING ▲**

When using a steam cleaner, wear safety glasses or a face shield, as well as protective clothing. Hot steam can cause serious personal injury.

**▲ WARNING ▲**

Wear appropriate eye and face protection when using compressed air. Flying debris and dirt can cause bodily injury.

- Steam-clean the air compressor and dry with compressed air.
- Drain the engine coolant if the air compressor has a liquid cooled cylinder head. If compressor is air cooled, then the engine coolant need **not** be drained. Refer to Procedure 008-018 if coolant needs to be drained.
- Open the draincock on the wet tank to release air from the system. Close the draincock after the pressure is released.

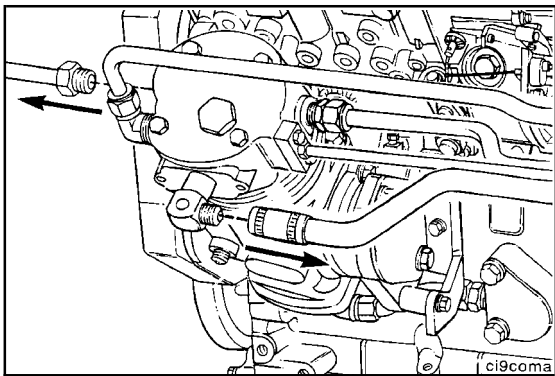

### Remove (012-101-002)

Remove the air connections from the air compressor.

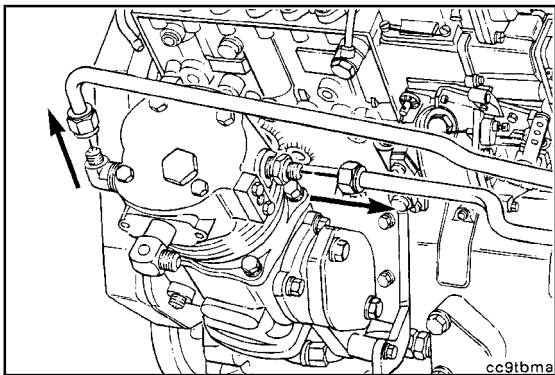

### 15/16 Inch, 7/8 Inch

Remove the coolant lines from the air compressor (does **not** apply to air cooled compressors).



**9/16 Inch**

Remove the oil supply line.

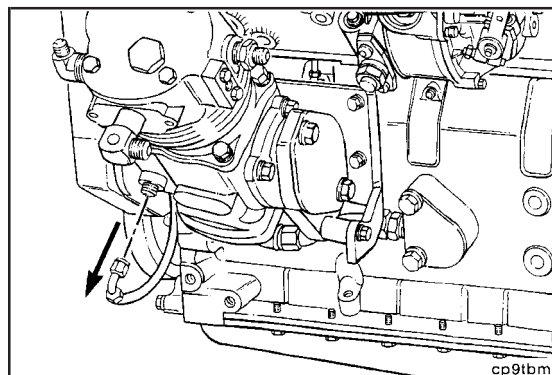

cp9tbmb

**15/16 Inch**

Remove the oil return line from the bottom of the air compressor.

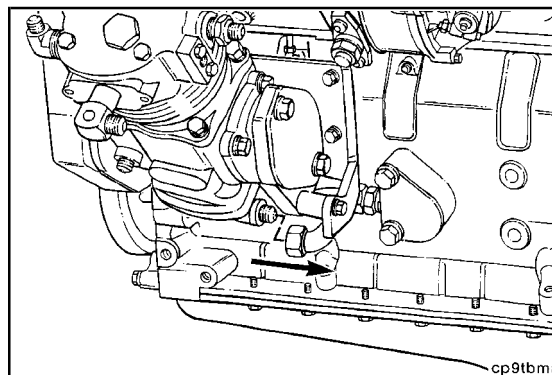

cp9tbma

**18 mm, 14 mm, 10 mm**

Remove the air compressor support bracket and capscrews.  
Remove the air compressor mounting nuts.  
Remove the air compressor.

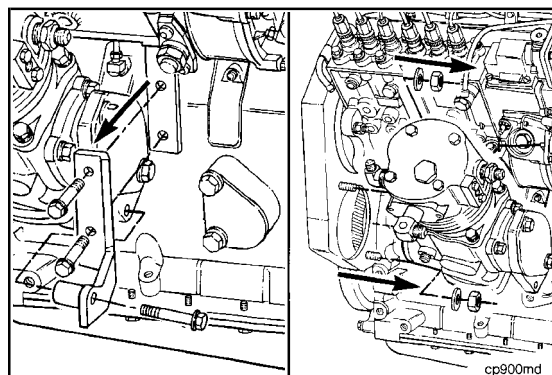

cp900md

**Disassemble (012-101-003)**

**1-1/4 Inch**

Remove the following parts:

- Unloader cover (1)
- Copper washer (2)
- Unloader pin (4)
- Spring (5).

Discard the copper washer.

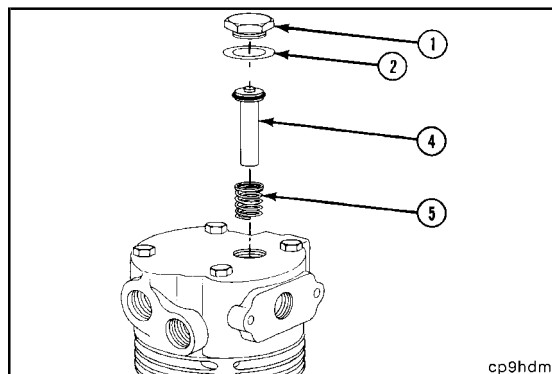

cp9hdma

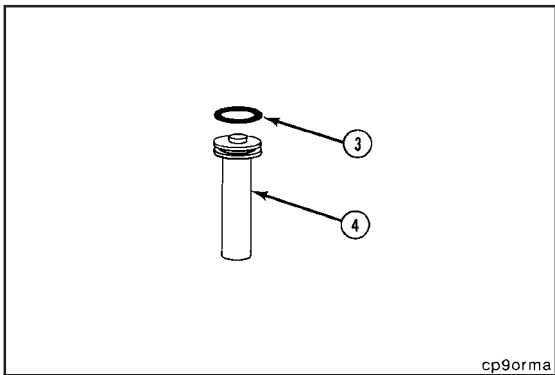

Remove and discard the o-ring (3) from the unloader pin (4).

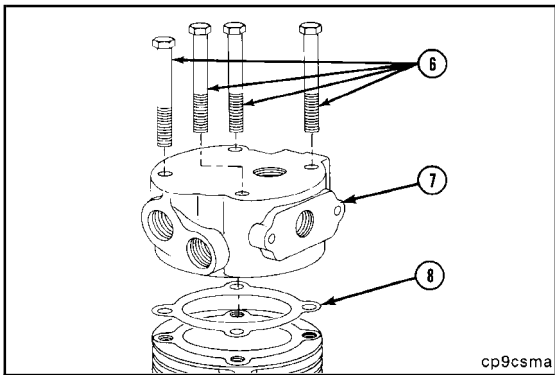

**9/16 Inch**

Remove the four cylinder head capscrews (6).



Remove the cylinder head (7).

Remove and discard the cylinder head gasket (8).

**Service Tip:** Scribe a mark to show proper head orientation before removing the head.

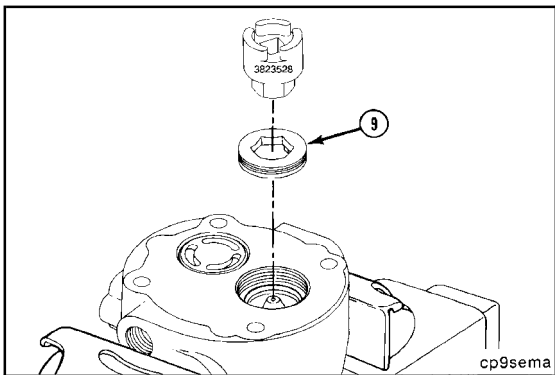

**Air Compressor Seat Socket or 3/4-Inch Allen Wrench, Part No. 3823528**

Install the head with the bottom side up in a soft-jawed vise.



Remove the exhaust valve seat (9).

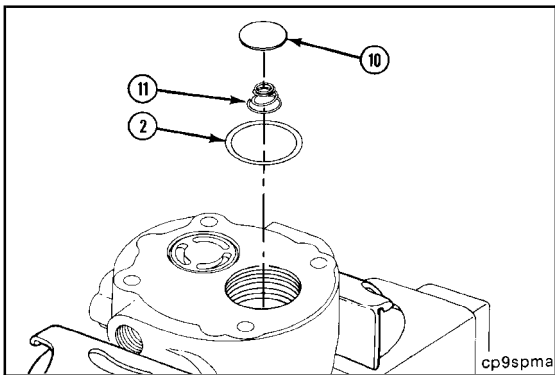

Remove the following parts:

- Exhaust valve disc (10)
- Spring (11)
- Copper washer (2).

Discard the copper washer.

**NOTE:** The exhaust valve stop is pressed in place and **must not** be removed.

**Air Compressor Seat Socket, Part No. 3823528**

Remove the inlet valve cage (12).

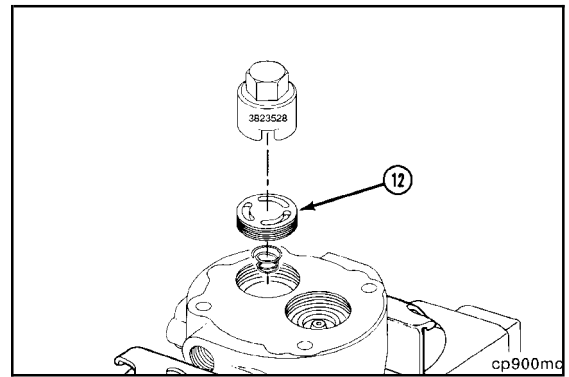

Remove the following parts:

- Spring (11)
- Inlet valve disc (10)
- Inlet valve seat (13)
- Copper washer (2).

Discard the copper washer

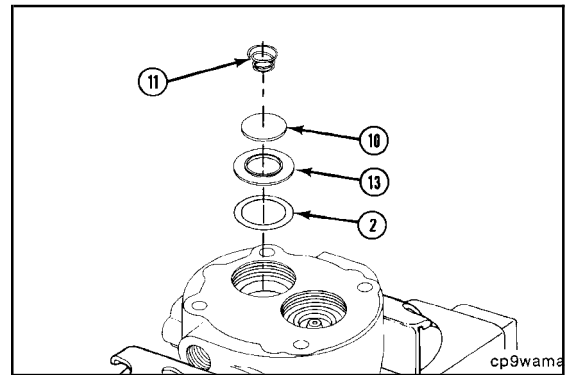

**Clean (012-101-006)**



**WARNING**

When using solvents, acids, or alkaline materials for cleaning, follow the manufacturer's recommendations for use. Wear goggles and protective clothing.



**WARNING**

Wear appropriate eye and face protection when using compressed air. Flying debris and dirt can cause bodily injury.

Soak the parts in a kerosene emulsion-based cleaner designed to remove carbon. The cleaner **must** have a pH of 9.5 or less to avoid turning aluminum parts black. The cleaner manufacturer or supplier can be contacted about solution concentration, temperature, and soak time.

Dry with compressed air.

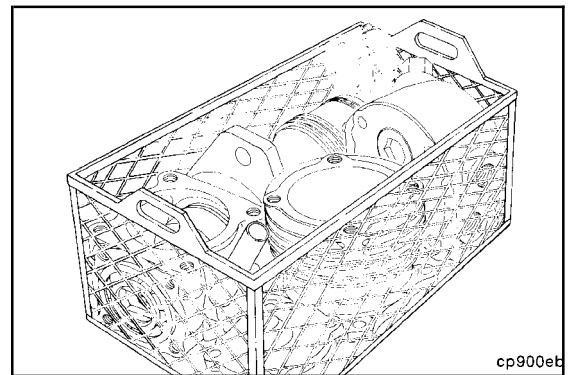

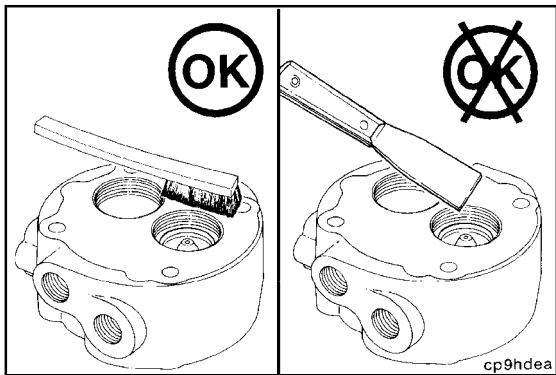

**CAUTION**

Do not use a scraper to remove carbon and scale. This can damage sealing surfaces.

Use a stiff, nonmetallic bristle brush to scrub the parts.

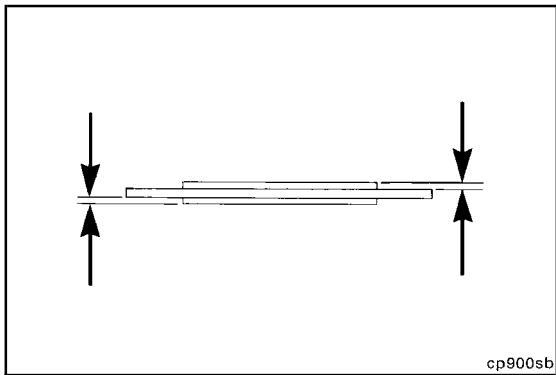

**Inspect for Reuse (012-101-007)**

**Valve Discs**



Inspect and replace if cracked, pitted, or grooved in excess of 0.13 mm [0.005 in].

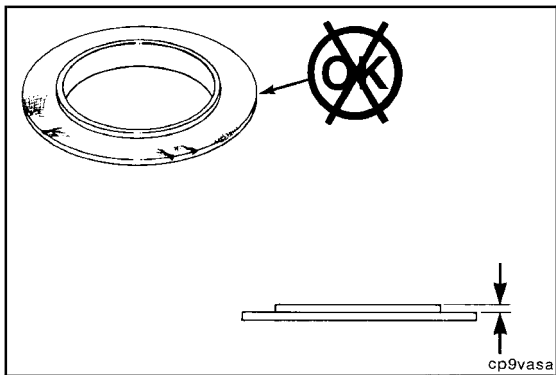

**Inlet Valve Seat**

Measure the distance from the valve seating surface to the surface that contacts the valve cage.



Intake Valve Seat		
mm		in
0.597	MIN	0.0235
0.673	MAX	0.0265

Replace the intake valve seat if **not** within limits or if cracked or damaged.

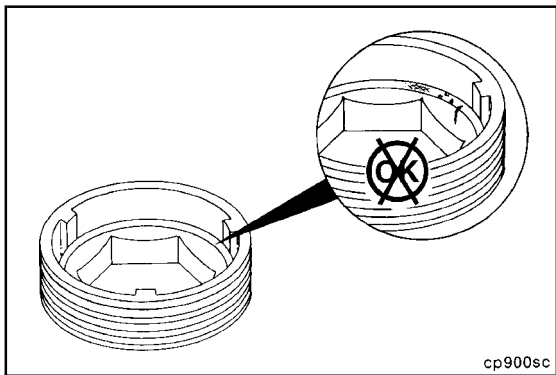

**Exhaust Valve Seat**

Inspect the seat for damage and wear.



**B3.9 and B5.9 Series Engines**  
**Section 12 - Compressed Air System - Group 12**

Measure the valve guide diameter.

Valve Guide Diameter		
mm		in
25.53	MIN	1.005
25.65	MAX	1.010

Replace the exhaust valve seat if **not** within limits.

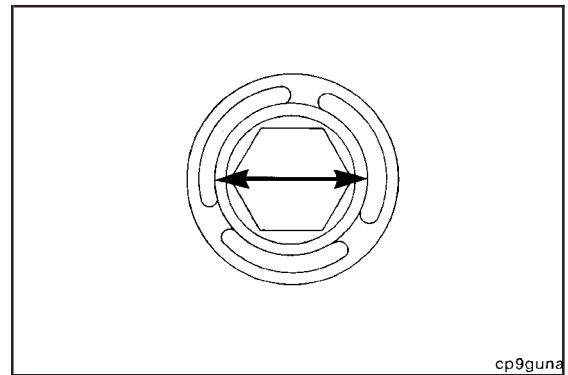

cp9guna

Measure the distance from the top of the valve seat to the valve seating surface.

Set Height		
mm		in
4.01	MIN	0.158
4.11	MAX	0.162

Replace the exhaust valve seat if **not** within limits.

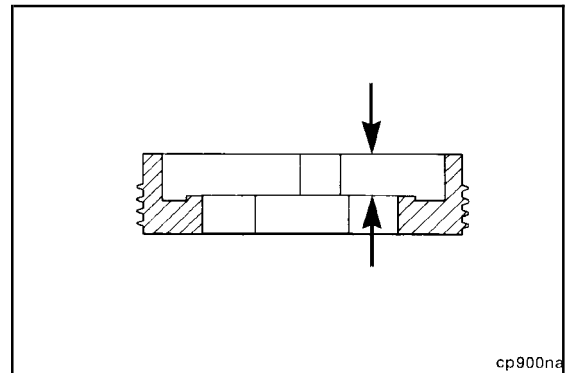

cp900na

**Inlet Valve Cage**

Inspect the inlet valve cage for damage and wear.

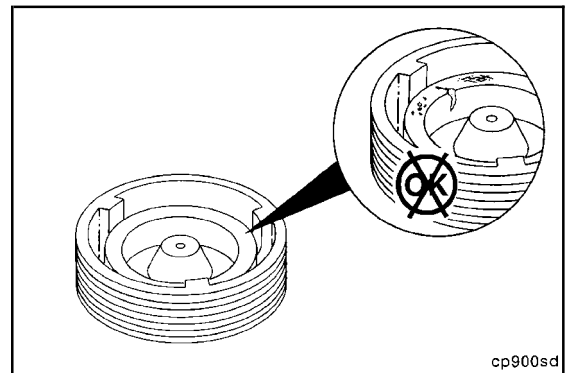

cp900sd

Measure the valve guide diameter.

Valve Guide Diameter		
mm		in
25.53	MIN	1.005
25.65	MAX	1.010

Replace the inlet valve cage if **not** within limits.

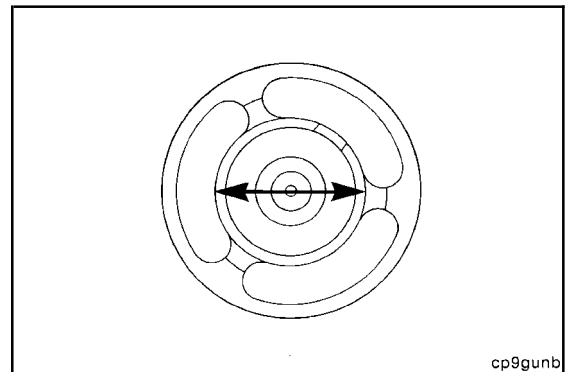

cp9gunb

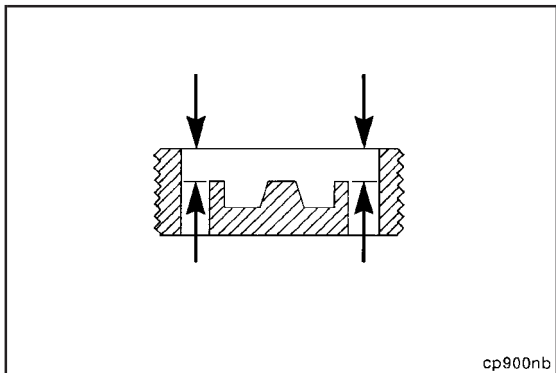

cp900nb



Measure the top of the cage to the valve stop.

Stop Depth		
mm		in
3.63	MIN	0.143
3.78	MAX	0.149

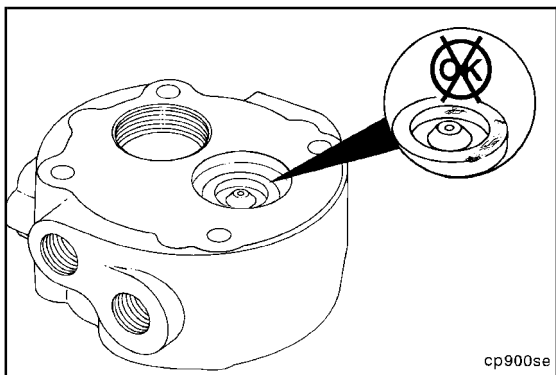

cp900se



**Exhaust Valve Stop**

Inspect the exhaust valve stop. Replace the cylinder head assembly if the stop is loose or damaged.

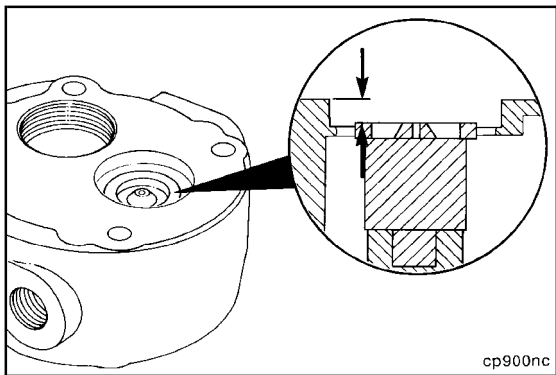

cp900nc



Measure the distance from the valve end of the stop to the face of the cylinder head.

Stop Height		
mm		in
4.42	MIN	0.174
4.70	MAX	0.185

Replace the cylinder head if **not** within limits.

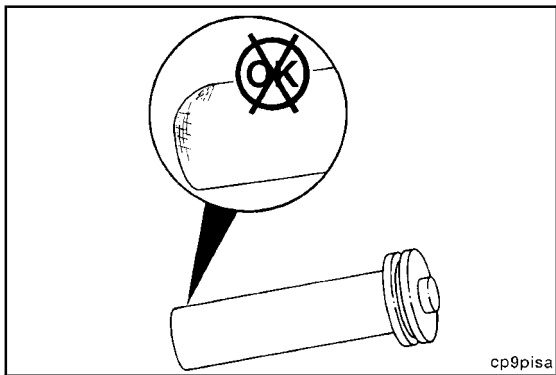

cp9pisa



**Unloader Pin**

Inspect for scoring or pitting.

Measure the length of the pin.

Pin Length		
mm		in
40.51	MIN	1.595
40.72	MAX	1.603

Replace the pin if **not** within limits.

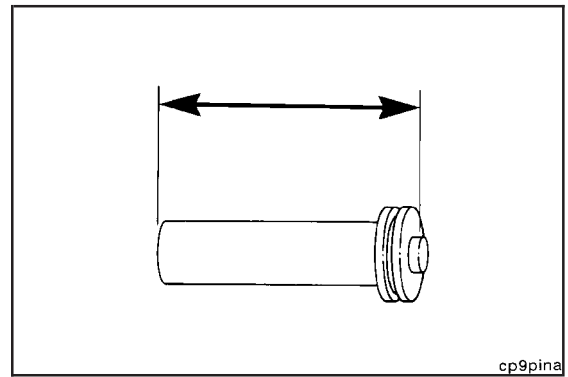

cp9pina

**Valve Springs**

**Valve Spring Tester, Part No. 3375182**

**NOTE:** Cummins Engine Company, Inc. recommends that new springs be installed during rebuild.

Use valve spring tester, Part No. 3375182, to check the springs.

Replace if **not** within limits in Table 1, shown below.

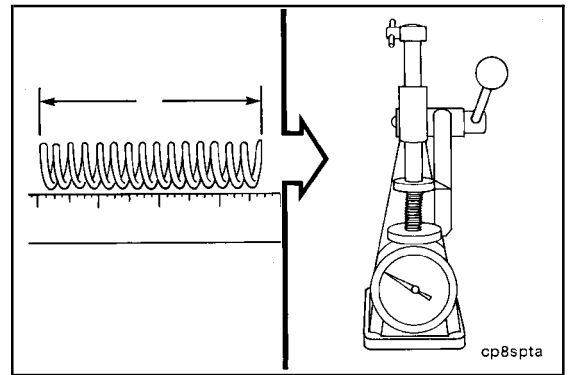

cp8spta

**Table 1: Spring Data**

	Load Required to Compress Spring to Length					
	Spring Length		Minimum			Maximum
	mm	in	Kg	lb	Kg	lb
Inlet Valve	5.08	0.20	0.272	0.60	0.340	0.75
Unloader	10.0330	0.395	1.53	3.37	1.90	4.19
Exhaust Valve	5.08	0.20	0.272	0.60	0.340	0.75

**Cylinder Head**

Inspect and replace if cracks, nicks, gouges, or damaged threads are found.

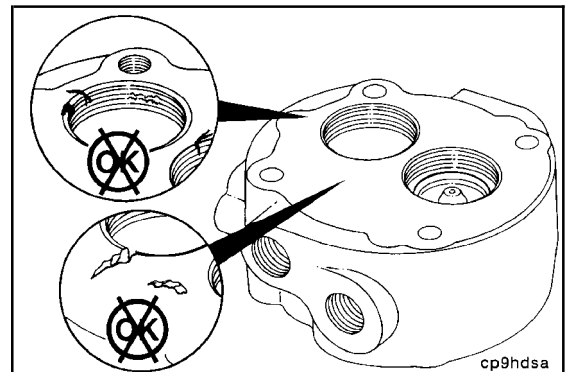

cp9hdsa

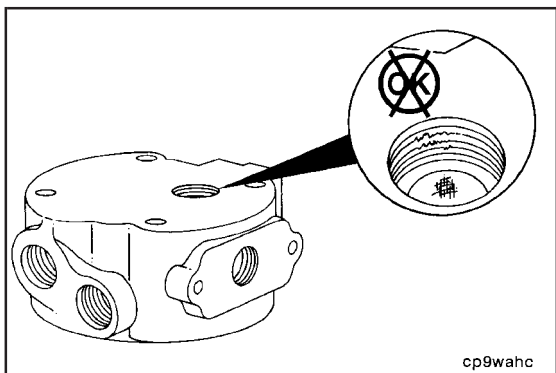

Inspect the unloader seal bore for scoring or pitting.  
Replace the cylinder head if damaged.

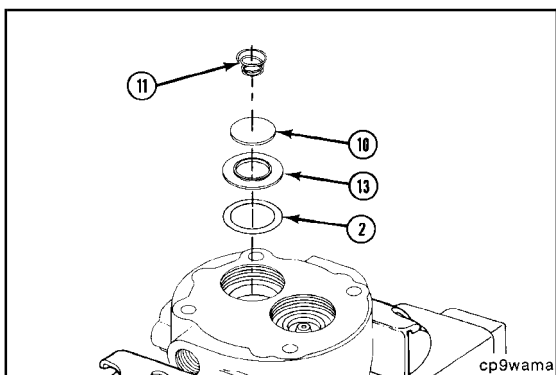

**Assemble (012-101-025)**

Turn the cylinder head bottom side up, and install it in a soft-jawed vise.

Install the following parts.

- a. New washer (2)
- b. Inlet valve seat (13)
- c. Inlet valve (10)
- d. Inlet valve spring (11).

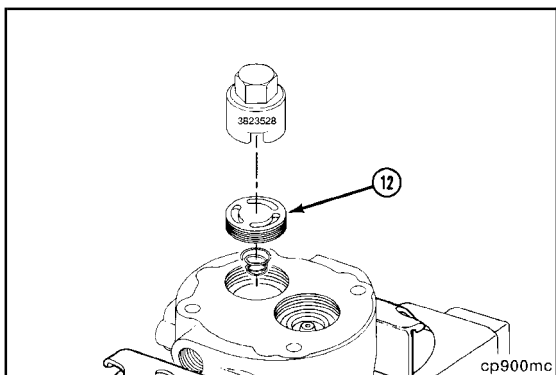

**Air Compressor Seat Socket, Part No. 3823528**

Tighten the cage (12).



**Torque Value:** 108 N•m [80 ft-lb]

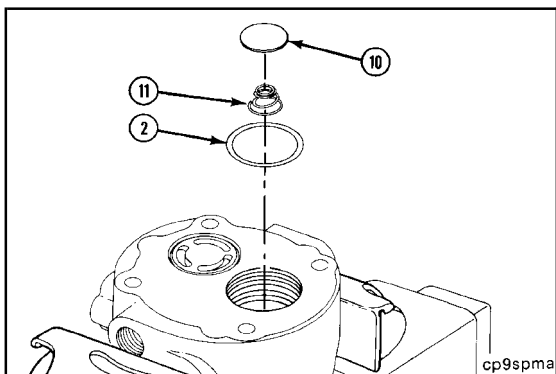

Install the following parts:

- a. New washer (2)
- b. Exhaust valve spring (11)
- c. Exhaust valve disc (10).

**B3.9 and B5.9 Series Engines**  
**Section 12 - Compressed Air System - Group 12**

**A/C Cylinder Head (SS 191 Model) (012-101)**  
**Page 12-31**

**Air Compressor Seat Socket, Part No. 3823528, or 3/4-Inch Allen Wrench**

Tighten the seat (9).

**Torque Value:** 108 N•m [80 ft-lb]

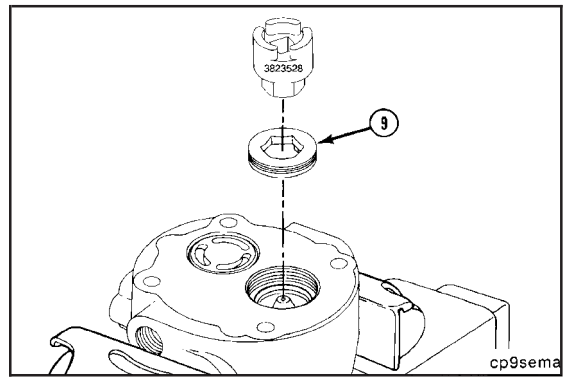

Install a new gasket (8) and the cylinder head (7) to the cylinder block, aligning the scribe marks.

Install the four capscrews (6).

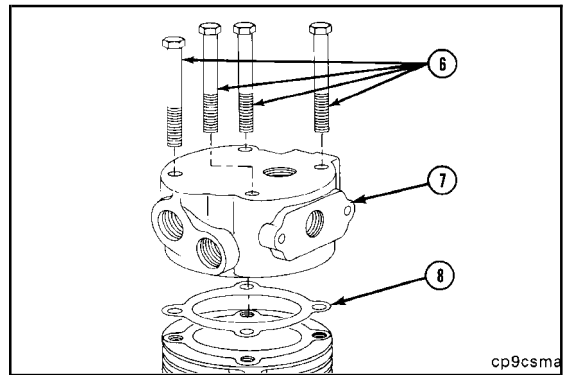

**9/16 Inch**

Tighten the capscrews.

**Torque Value:** 30 N•m [22 ft-lb]

Tighten the capscrews again, in the sequence shown.

**Torque Value:** 41 N•m [30 ft-lb]

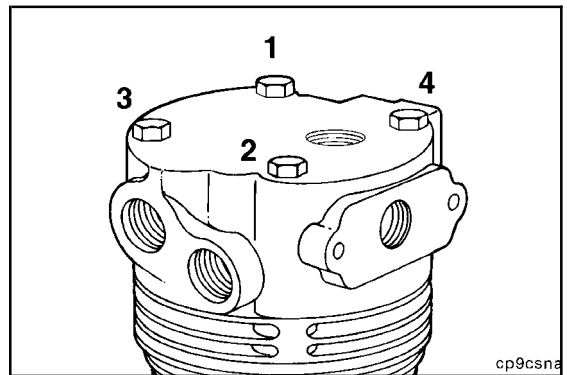

Install a new o-ring (3) on the unloader pin (4).

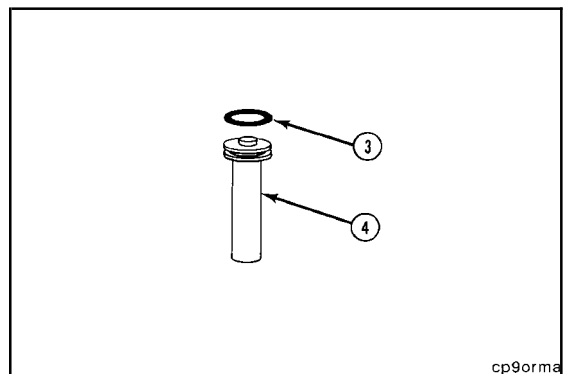

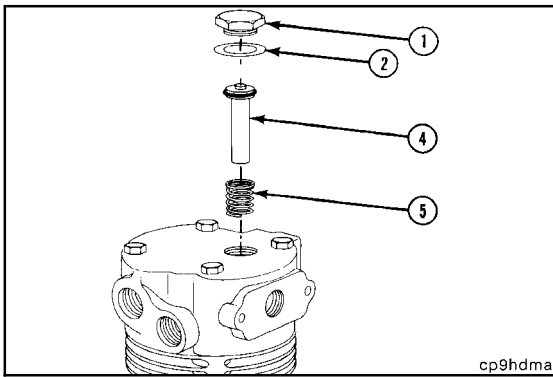

1-1/4 Inch

Install the following parts:



- a. Spring (5)
- b. Unloader pin (4)
- c. New washer (2)
- d. Unloader cover (1).



Tighten the cover.

**Torque Value:** 41 N•m [30 ft-lb]

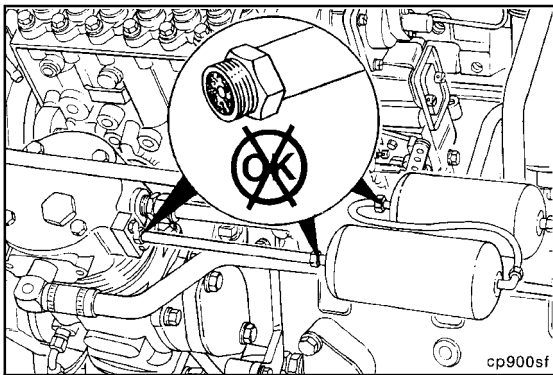

**▲ WARNING ▲**

The air discharge line must be capable of withstanding extreme heat and pressure to avoid the possibility of personal injury and property damage. Refer to the manufacturer's specifications.



Continue to check for carbon buildup in the air discharge line connections up to the first or wet tank.



Clean or replace any lines and fittings with carbon deposits greater than 1.6 mm [0.06 (1/16) in]. Refer to the manufacturer's specifications for cleaning or replacement instructions.

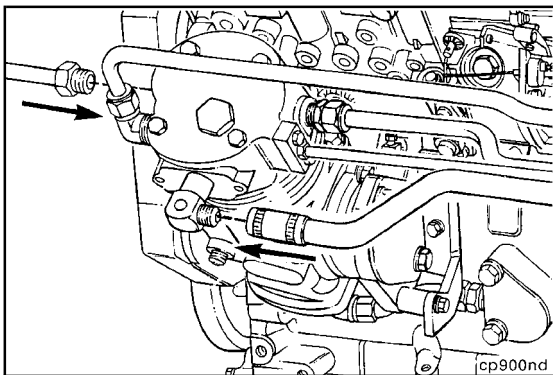

Install and tighten the air inlet and outlet connections.

**Torque Value:**

Inlet	5 N•m	[44 in-lb]
*Outlet	24 N•m	[18 ft-lb]



\*1/2 NPT fitting in head

**NOTE:** Torque of the discharge line is dependent upon line size and type. Consult vehicle manufacturer for correct torque value.

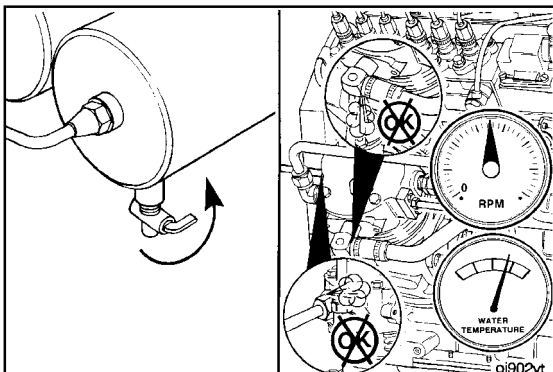

Close the wet tank draincock.

Operate the engine, and check for air leaks.

**Install (012-101-026)**

**Air Compressor Timing (for single-cylinder air compressor only)**

Locate TDC on the compressor crankshaft by removing the unloader valve or head (refer to the respective air compressor manual). TDC does **not** have to be exact. The system is tolerant of some misalignment.

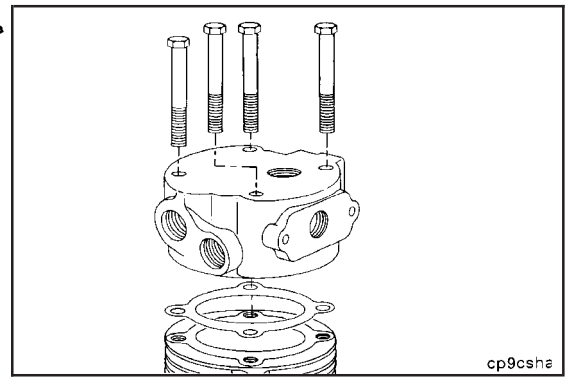

Use ink or dykem to mark the air compressor gear face at TDC (12-o'clock position when viewed from the front).

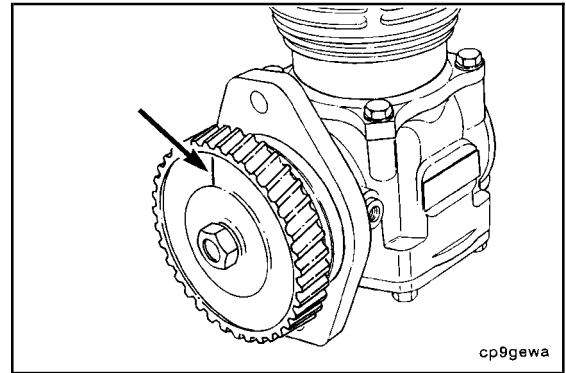

Be sure to disengage the timing pin after locating TDC. Locate TDC for cylinder No. 1 by barring the crankshaft slowly while pushing on the timing pin.

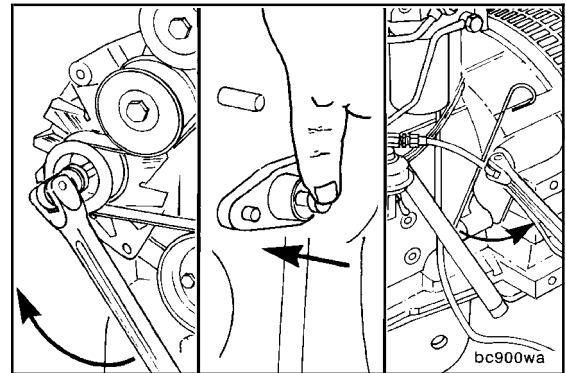

Rotate the compressor TDC mark to 60 degrees, or 6 teeth on a 36-tooth gear, before TDC. This is approximately 10-o'clock when viewed from the front of the air compressor.

**NOTE:** Holset® air compressors Series SS, QE296 and 338 will have a radial line etched on the gear representing TDC.

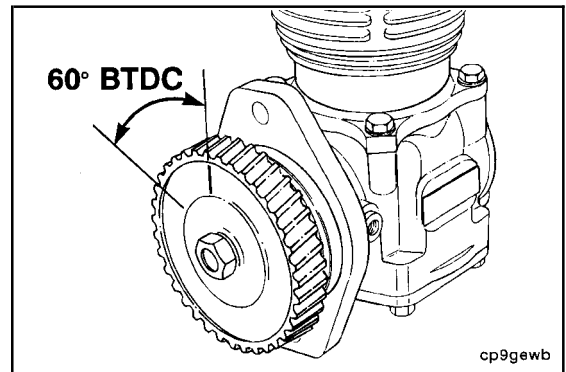

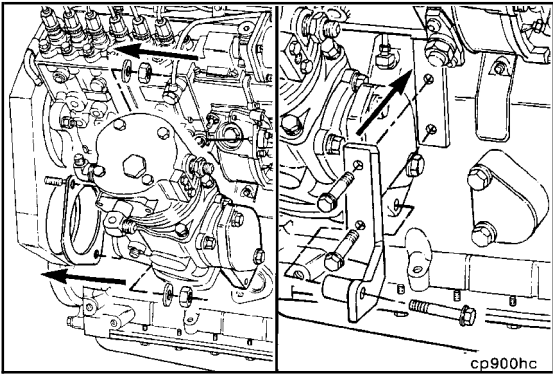

18 mm, 14 mm, 10 mm

Use a new gasket. Install the air compressor to the gear housing.



Install the air compressor support bracket.

**Torque Value:**

Mounting Nuts 77 N•m [57 ft-lb]

Support Capscrews 24 N•m [18 ft-lb]



**NOTE:** No timing of gears is necessary.

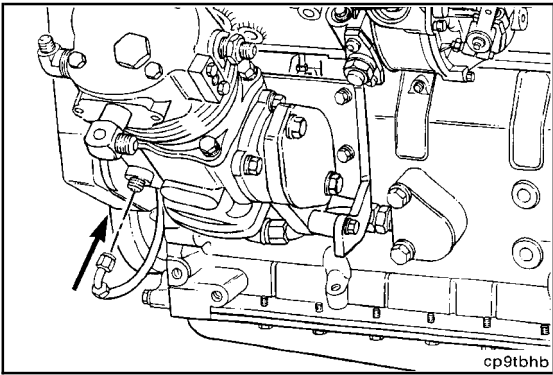

9/16 Inch

Install the oil supply line.



**Torque Value:** 15 N•m [133 in-lb]

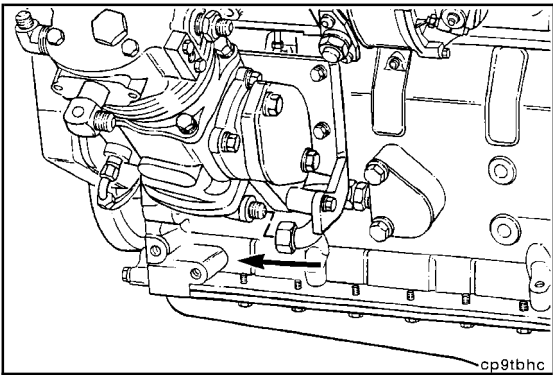

15 mm

Install the oil drain to the bottom of the compressor.



**Torque Value:** 24 N•m [18 ft-lb]

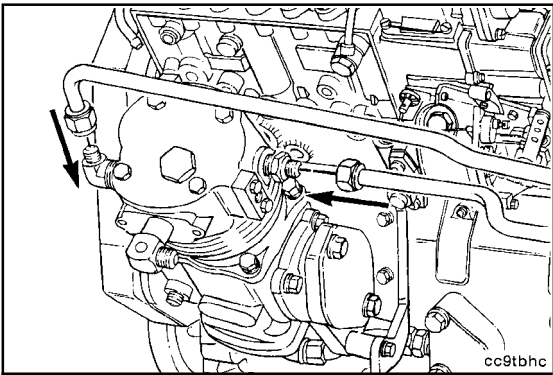

15/16-Inch, 7/8-Inch

**▲ CAUTION ▲**

If rubber grommets are used on the coolant or air lines, be sure they are installed carefully to prevent cuts or tears to the grommets, which will cause leaks.



Install the coolant lines.



**Torque Value:** 24 N•m [18 ft-lb]



Install the air lines.

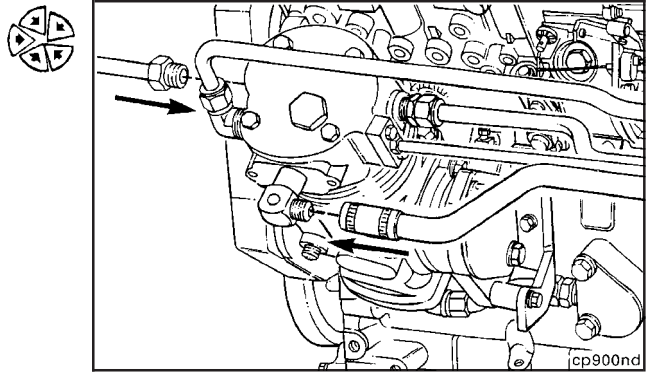

Fill the engine cooling system (liquid cooled air compressor only).

Operate the engine and check for leaks.

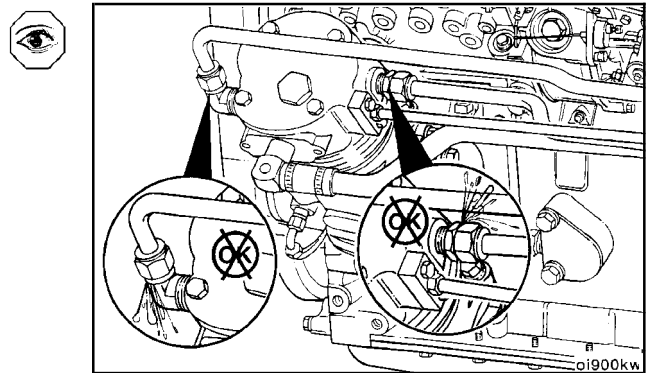

Operate the engine to activate the air compressor.

With the air compressor pumping between 550 to 690 kPa [80 to 100 psi], use a solution of soapy water to check for air leaks.

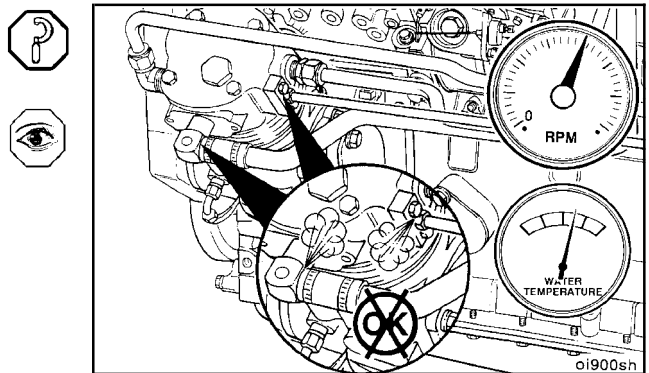

### Air Compressor Cylinder Head (Holset® QE Models) (012-104)

#### General Information

The compressed air system normally consists of a gear-driven air compressor, an air governor, air tanks and all necessary plumbing.

The Holset® single-air compressors are engine-driven, piston-type compressors that supply compressed air to operate air-activated devices. The compressor runs continuously, but has a loaded and unloaded operating mode.

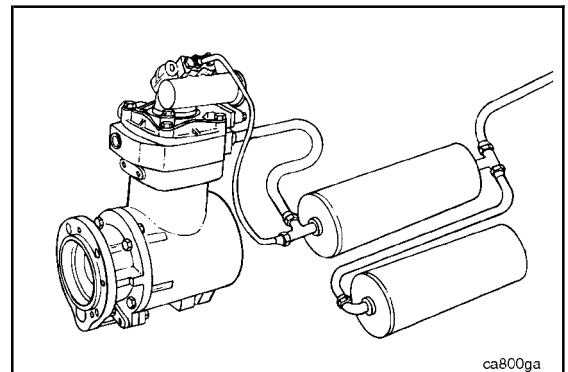

**E-Type Air Compressor**

Holset® SS model air compressors built with the E-Type unloader can be identified by the letter "E" (SS296E, and SS338E) and by the caution on the dataplate.

All QE (QE296 and QE338) model air compressors are equipped with the E-Type unloader.

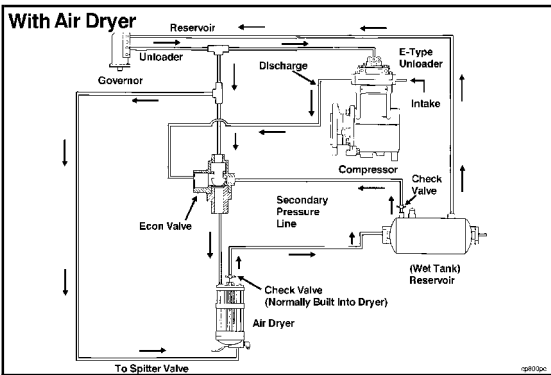
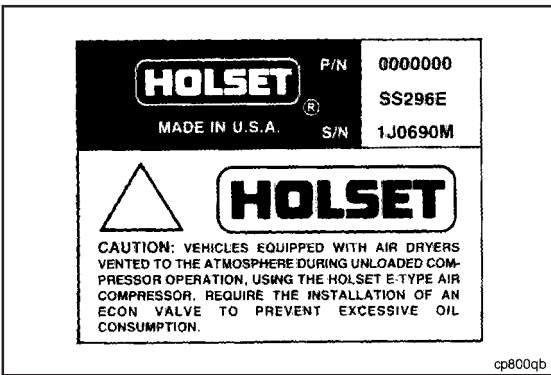

**E-Type System with Air Dryer**

Vehicles equipped with air dryers vented to the atmosphere during unloaded compressor operation, using the Holset® E-Type air compressor, require the installation of an econ valve to prevent excessive oil consumption.

**NOTE:** Some air dryers can have a built-in econ valve. Check with the manufacturer as to which type is installed.

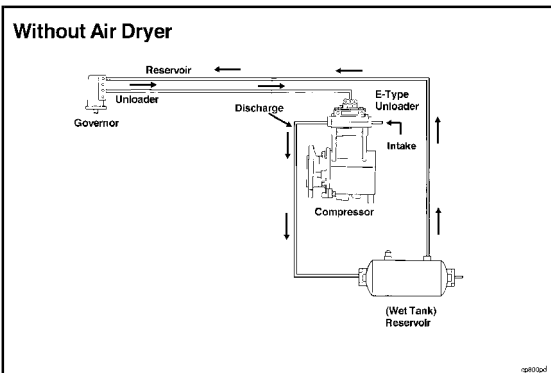

**E-Type System without Air Dryer**

Air systems **without** air dryers, or with air dryers **not** vented to the atmosphere during unloaded compressor operation, can use the Holset E-Type unloader valve without modifying the air system.

**Disassemble (012-104-003)**

**▲ WARNING ▲**

Coolant is toxic. Keep away from pets and children. If not reused, dispose of in accordance with local environmental regulations.

**▲ WARNING ▲**

Do not remove the pressure cap from a hot engine. Wait until the coolant temperature is below 50°C [122°F] before removing the pressure cap. Heated coolant spray or steam can cause personal injury.

**NOTE:** If the cylinder head is removed while the air compressor is on the engine, drain the engine coolant. Refer to Procedure 008-018.

**NOTE:** Since the valve plate, head, and unloader body are indexible, marking these parts is recommended to make sure they are reassembled in the proper orientation.

**▲ WARNING ▲**

The unloader body is installed with spring tension. Use care when removing to prevent personal injury. Always wear protective eyewear.

Hold the unloader valve body down, and remove the four capscrews.

Remove the unloader valve body.

Remove the unloader valve spring.

Remove the unloader valve cap.

Remove the unloader body gasket and unloader valve cap rectangular ring seal.

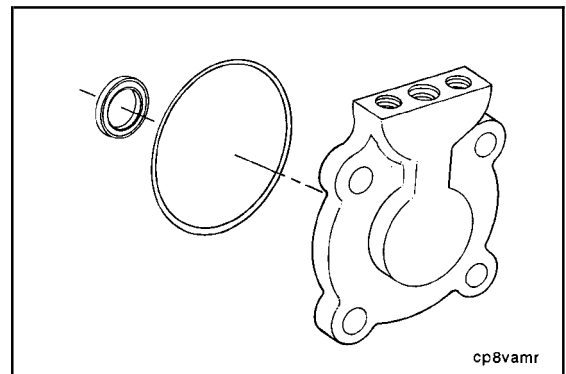
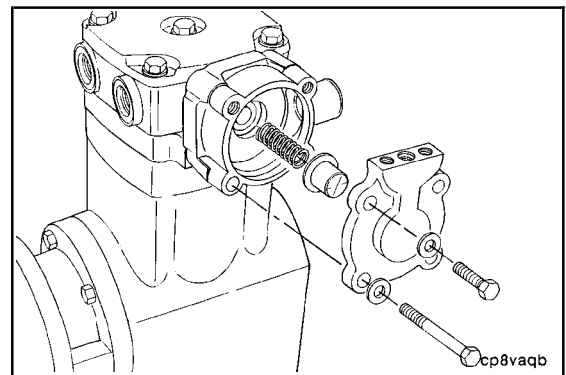
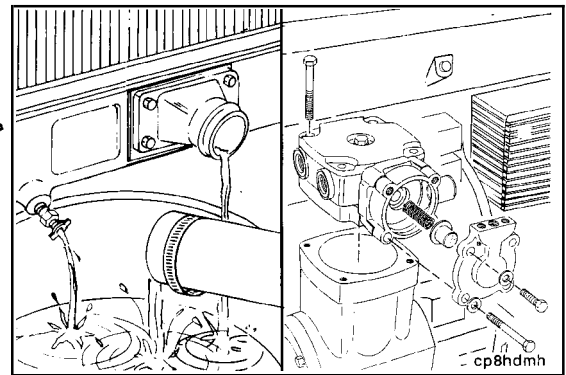

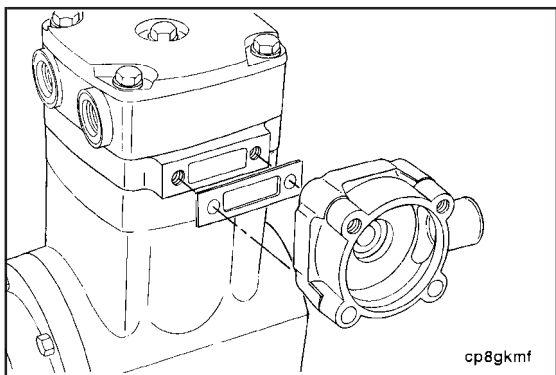

Remove the compressor intake manifold and gasket.

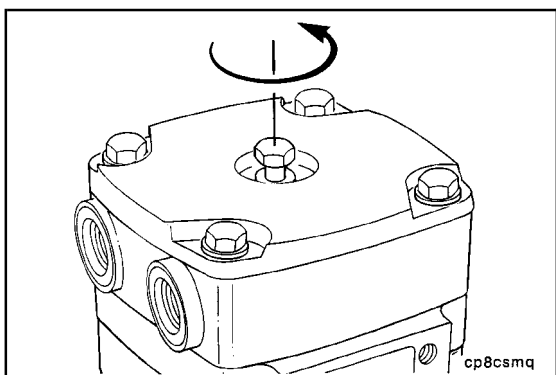

Loosen, but do **not** remove, the center head capscrew.  
Mark the head for orientation during assembly.

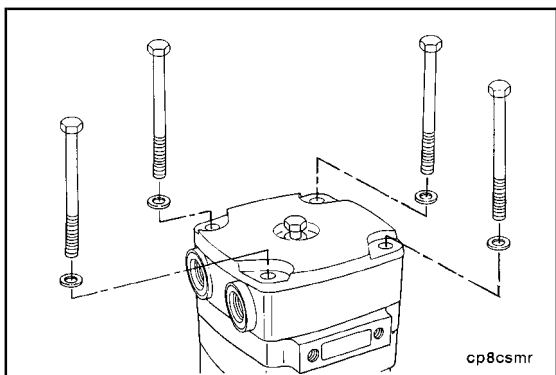

Loosen and remove the four corner head capscrews. Save the capscrews for reuse.

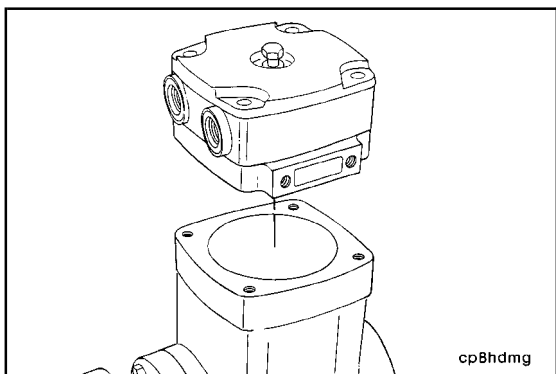

Remove the head, cover, and valve plate assembly and place it on a clean work surface with the intake valve facing upward.

**NOTE:** If continuing with disassembly of the head, valve plate, and cover, be sure the work surface is clean. Grit pushed into the valve sealing surfaces by setting components on a dirty surface will cause a malfunction after assembly.

Some units have a press-fit intake valve retainer. If present, carefully remove it to prevent part damage.

Remove the intake valve.

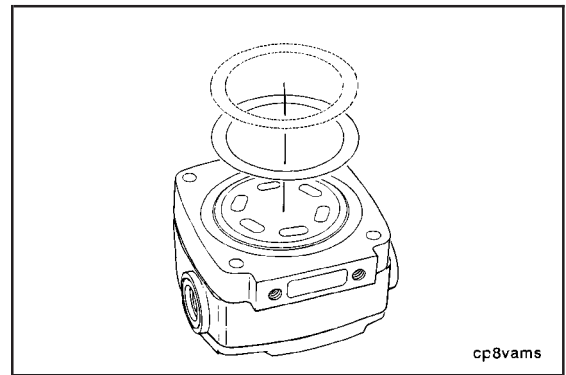

Turn the head assembly over and set it on a clean surface. Remove the center capscrew. This capscrew can be re-used.

**NOTE:** The center capscrew is shorter than the four corner capscrews.

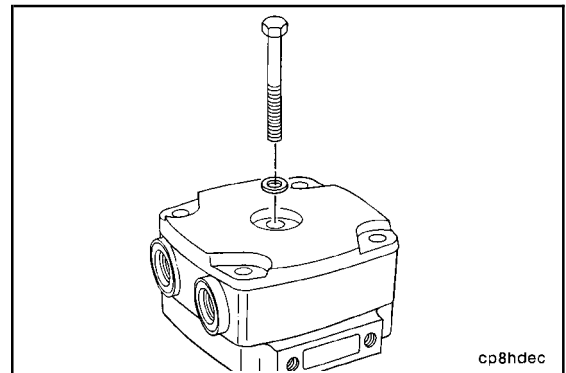

Remove the cover, cover gasket, head, and head gasket.

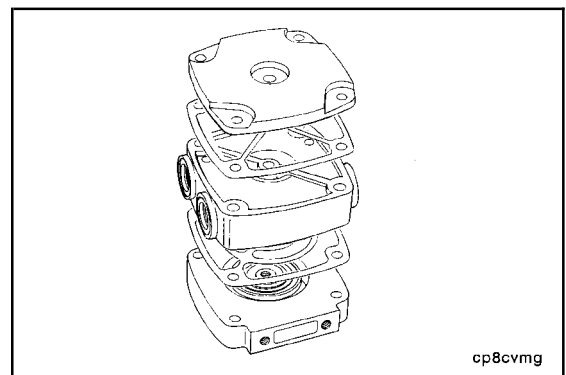

Remove the exhaust valve retainer and exhaust valve.

**NOTE:** The wave washers **must** be replaced.

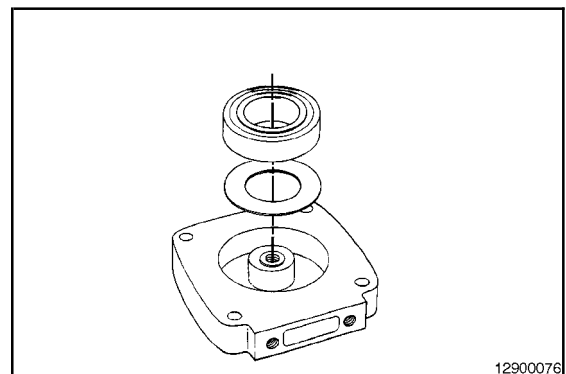

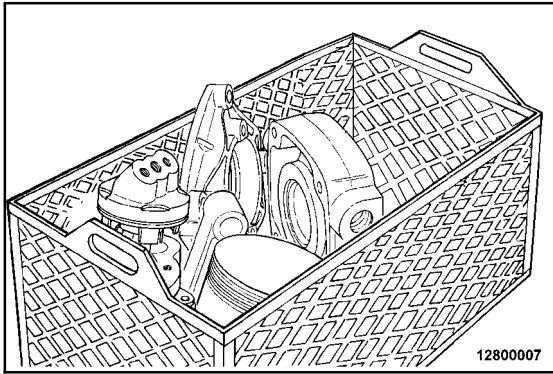

**Clean (012-104-006)**



**When using solvents, acids, or alkaline materials for cleaning, follow the manufacturer's recommendations for use. Wear goggles and protective clothing.**

Soak the parts in a kerosene emulsion-based cleaner designed to remove carbon. The cleaner **must** have a pH of 9.5 or less to avoid turning aluminum parts black. The cleaner manufacturer or supplier can be contacted about solution concentration, temperature, and soak time.

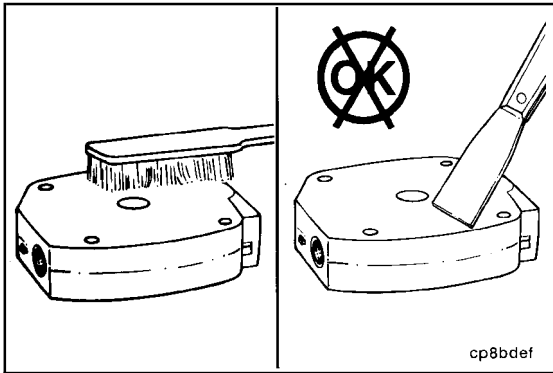

**NOTE:** Do **not** use a scraper to remove carbon and scale; the sealing surfaces can be damaged.

The parts can be scrubbed with a stiff, nonmetallic bristle brush.

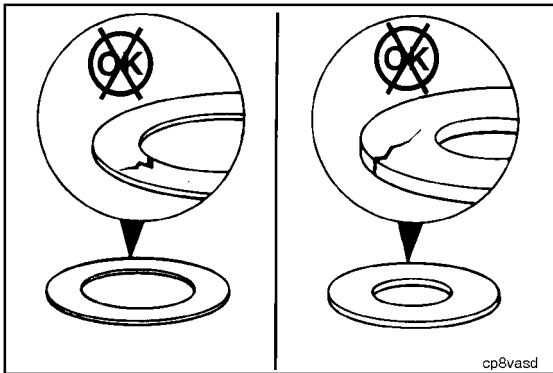

**Inspect for Reuse (012-104-007)**

Inspect the intake and exhaust valves for cracks or damage.

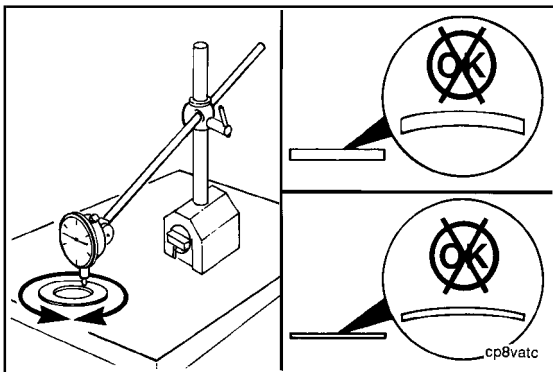

Measure the flatness of the intake and exhaust valves. Both valves **must** be flat within 0.03 mm [0.001 in].

Replace valves if cracked, damaged, or **not** flat.

**NOTE:** Holset® Engineering Co., Inc., recommends new valves be installed.

**B3.9 and B5.9 Series Engines**  
**Section 12 - Compressed Air System - Group 12**

Inspect the upper part of the unloader valve cap where the rectangular v-seal operates. Check for scoring.

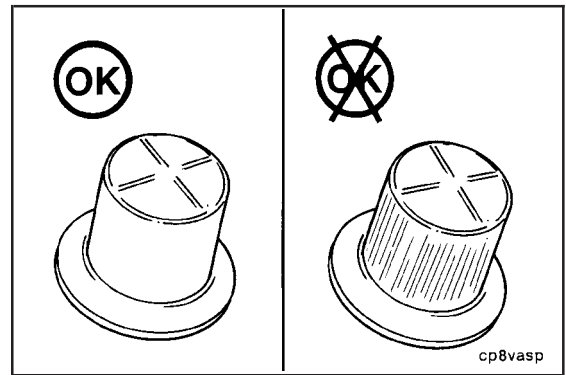

Inspect the valve seat surfaces.

**NOTE:** Inspection of the valve seats in the valve plate requires specialized equipment and is beyond the scope of field service.

If the valve seat is visibly damaged, or can **not** be cleaned, a new valve plate is available in a service kit. Otherwise, a QE valve plate service assembly can be used.

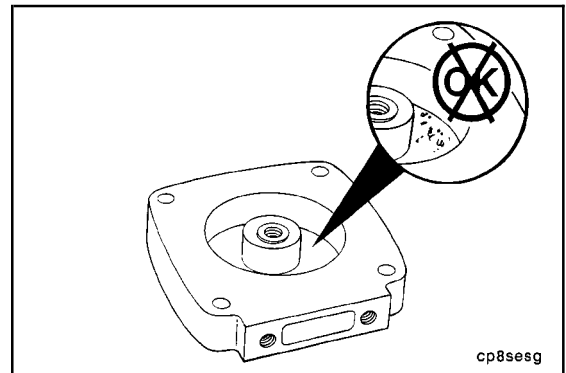

Gasket sealing surfaces **must** be clean and free of all old gasket material, carbon, rust, and other buildup. Surfaces **must** be free of scratches, gouges, burrs, and other deformities.

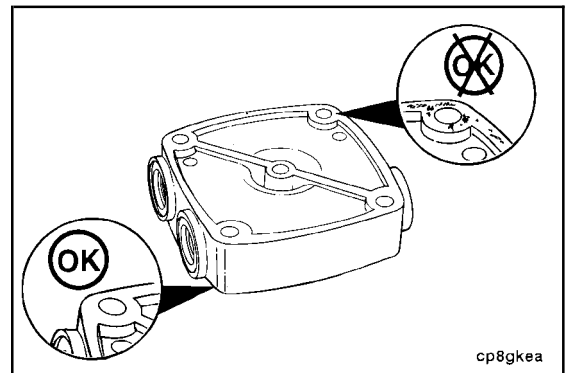

After making sure all gasket surfaces are clean and free of the above, inspect the head and cover for flatness. Use the flat plate and the feeler gauges.

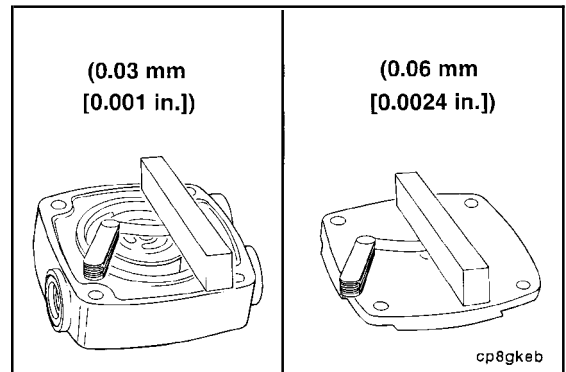

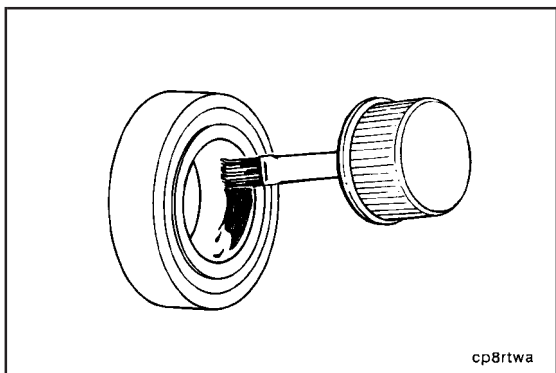

Apply a thin coating of anti-seize compound to the inside diameter of the exhaust valve retainer.

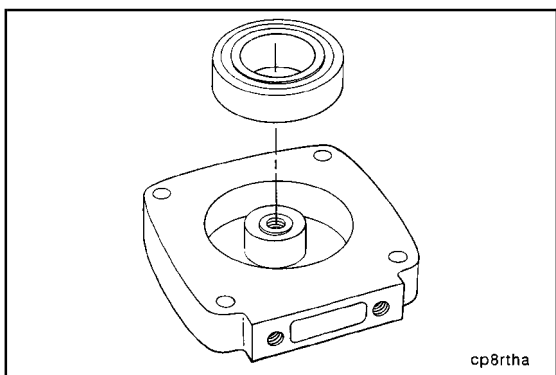

Slide the exhaust valve retainer over the valve plate. Make sure that the end of the retainer with the groove faces upward.

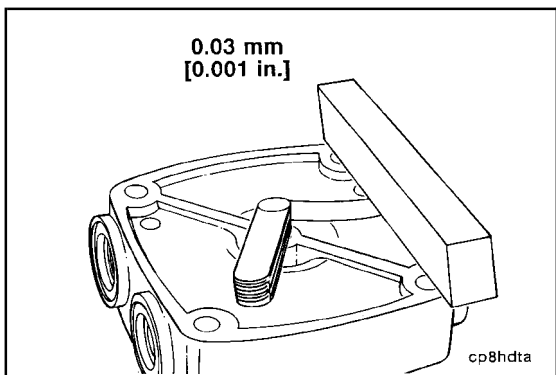

Single-cylinder heads **must** be flat within 0.03 mm [0.001 in] between any two adjacent capscrew holes.

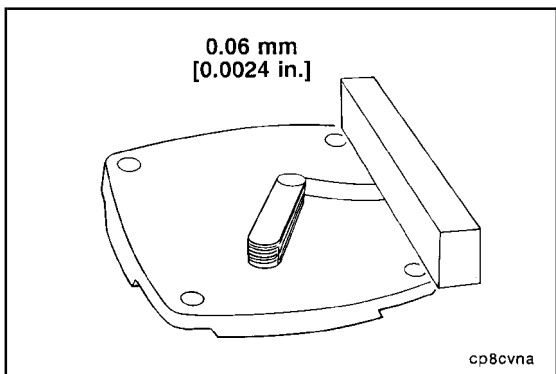

Single-cylinder top cover **must** be flat within 0.06 mm [0.0024 in] between any two adjacent capscrew holes and 0.10 mm [0.004 in] total.



**B3.9 and B5.9 Series Engines**  
**Section 12 - Compressed Air System - Group 12**

**Valve Spring Tester, Part No. 3375182**

Use the valve spring tester, Part No. 3375182, to check the unloader valve spring (blue stripe).

Replace any spring that does **not** meet specifications.

Compress springs to 24.9 mm [0.98 in].

Force Specification		
kg		lb
10.4	MIN	23
12.5	MAX	27

**NOTE:** Holset® recommends new springs be installed.

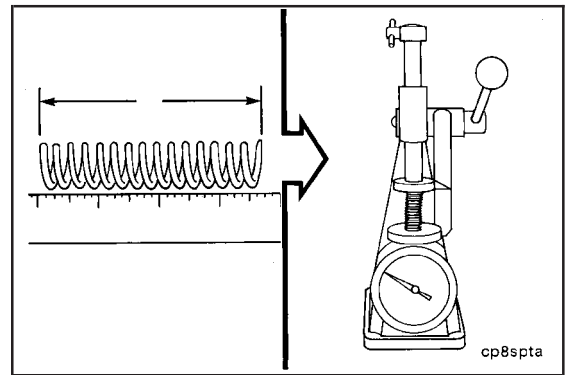

**Assemble (012-104-025)**

**QE, Non-European**

Install the exhaust valve over the post in the valve plate.

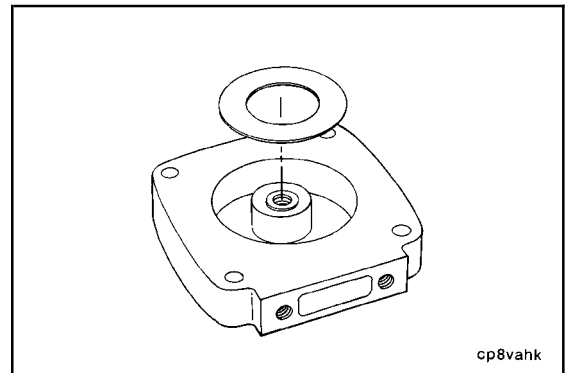

Apply a thin coating of anti-seize compound to the inside circumference of the exhaust valve retainer.

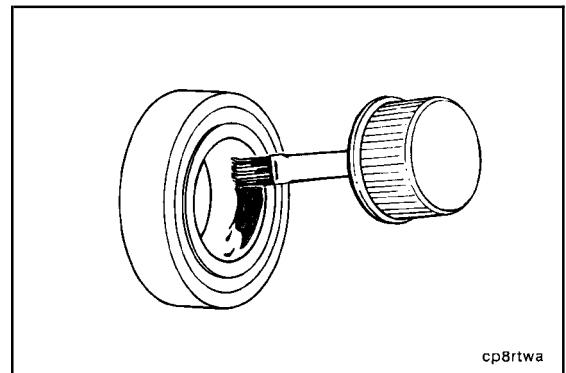

Slide the exhaust valve retainer over the valve plate. Make sure that the end of the retainer with the groove faces upward.

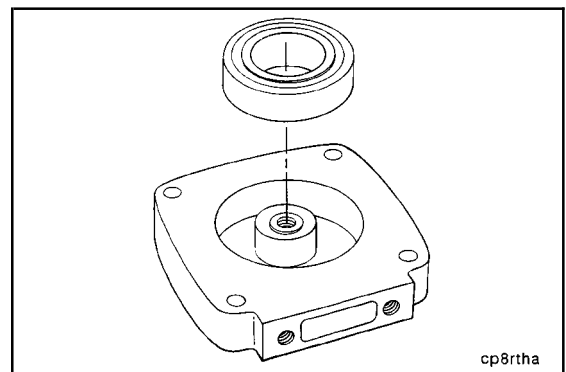

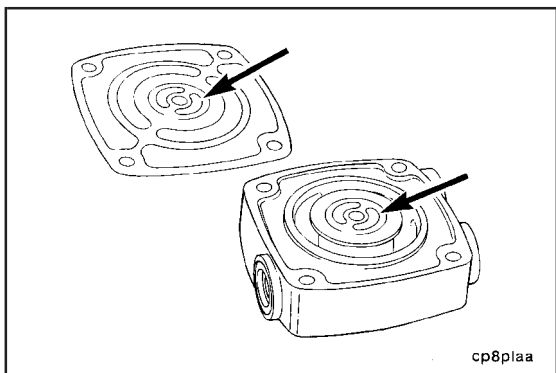

Determine the final orientation of the valve plate (air intake location) and the head (coolant ports in relation to air inlet or manifold location). Align the kidney-shaped slots in the head with the kidney-shaped slots in the gasket.

If orientation marks were made before disassembly, use them.

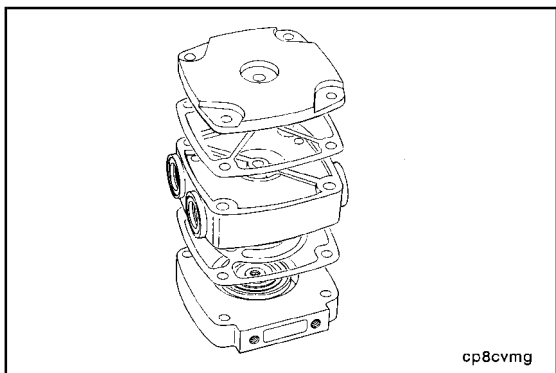

Assemble the cover, cover gasket, head, head gasket, and valve plate.

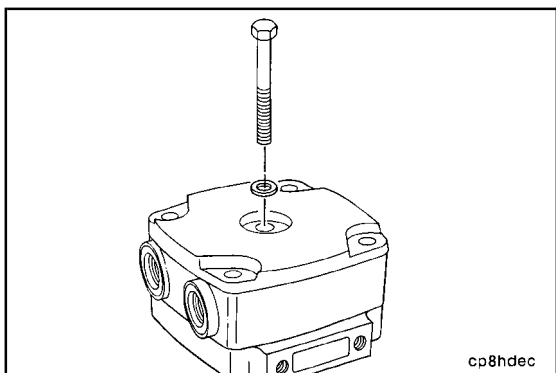

**NOTE:** Make sure corner capscrew holes are aligned.

Lubricate the threads under the head.



Install the shorter capscrew with washer through the center hole.

**Torque Value:** 14 N•m [124 in-lb]

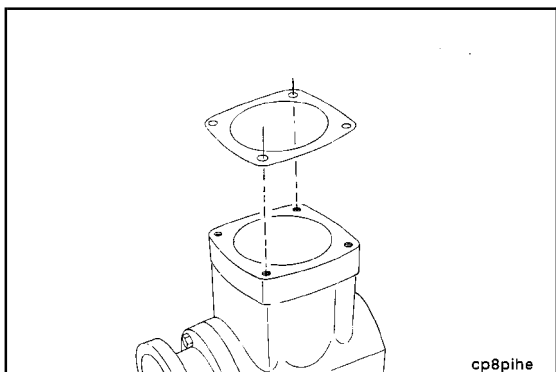

Install the valve plate gasket.

Carefully place the intake valve in the valve plate. Install the intake valve retainer.

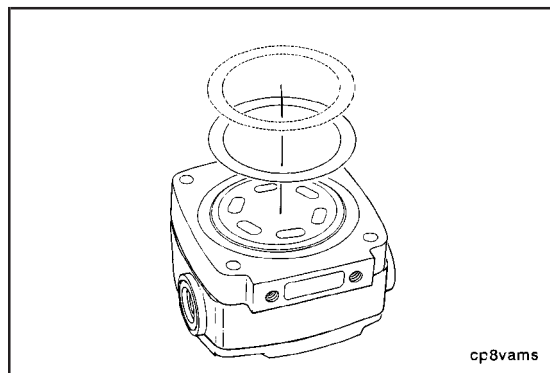

Install the valve plate assembly.

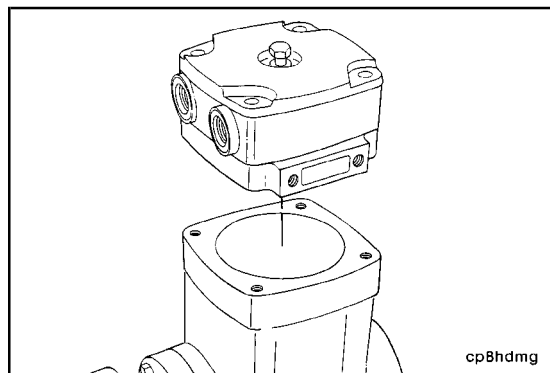

Lubricate the threads under the head and washer of the capscrews, if initially installed.

Install the four head capscrews and washers.

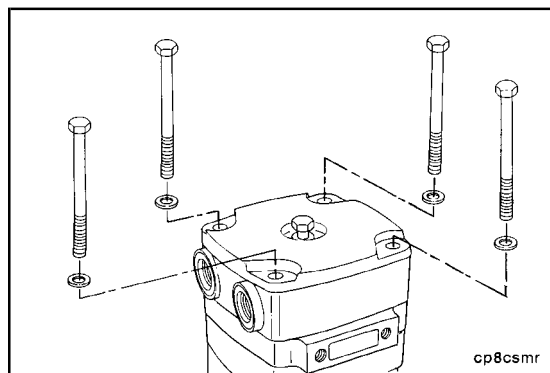

Tighten all five capscrews in the proper sequence.

**Torque Value:** 28 N•m [21 ft-lb]

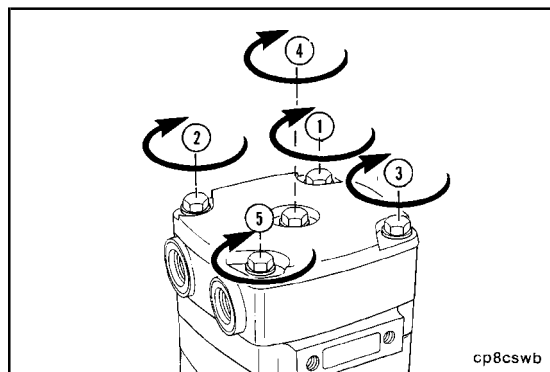

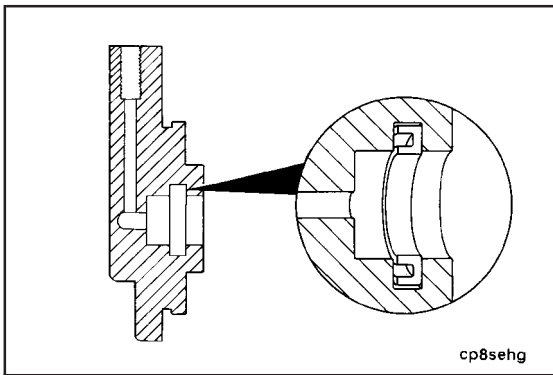

Install the new rectangular v-seal into the unloader body.

**NOTE:** The seal **must** be installed with the grooved side up.



Liberaly lubricate the unloader valve bore above and below the rectangular ring seal with high-temperature grease (Accrolube lubrication Teflon™ grease or equivalent).

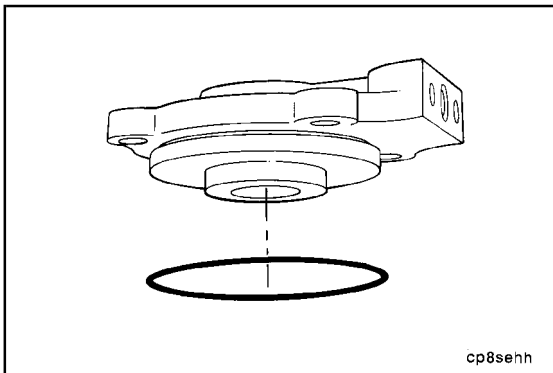

Install a new o-ring seal on the unloader valve body.

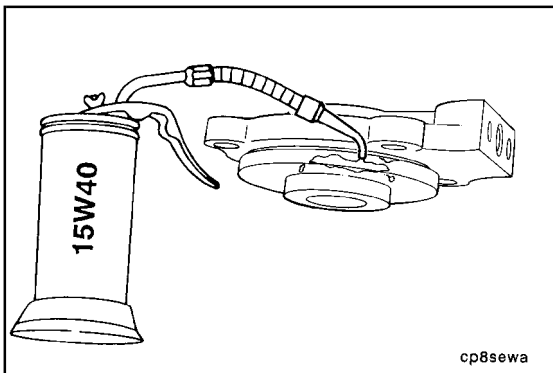

Use clean lubricating engine oil or Accrolube lubrication Teflon™ grease, or equivalent, to lubricate the seal.

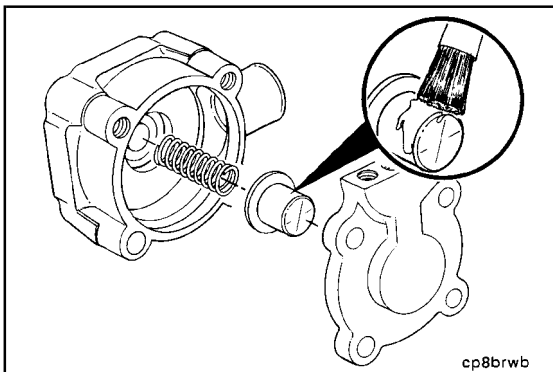

Liberaly lubricate the unloader valve body bore and unloader cap with high-temperature grease (Accrolube lubrication Teflon™ grease or the equivalent).



Install the unloader cap.

Install the unloader spring.

**B3.9 and B5.9 Series Engines**  
**Section 12 - Compressed Air System - Group 12**

Lubricate the unloader screw threads and underhead with clean lubricating engine oil before installation.

**NOTE:** The two unloader body screws **must not** be used to attach any brackets.

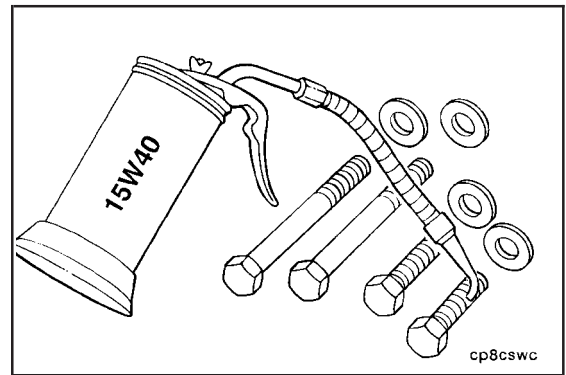

Assemble the unloader components, and attach the unloader assembly to the valve plate with the four capscrews and washers.

**NOTE:** The longer capscrews are used to mount the manifold to the air compressor.

**Torque Value:** 27 N•m [20 ft-lb]

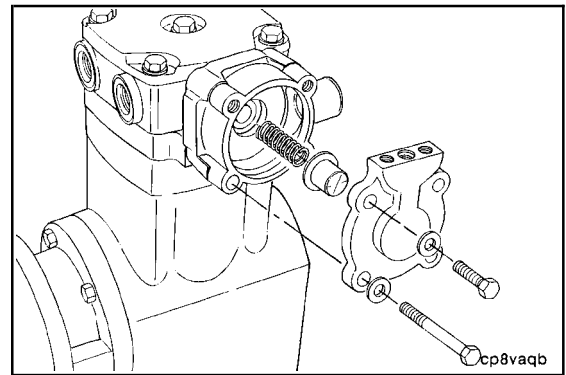

**QE, European**

Install the exhaust valve over the post in the valve plate.

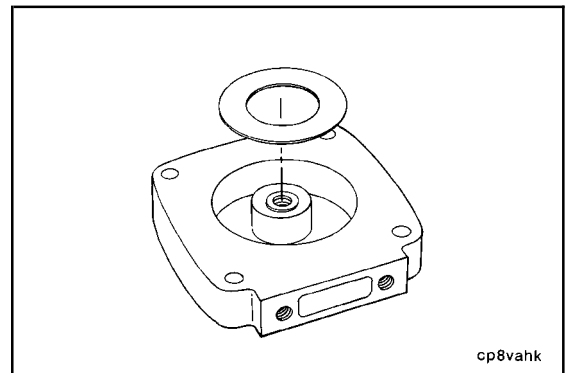

Apply a thin coating of anti-seize compound to the inside circumference of the exhaust valve retainer.

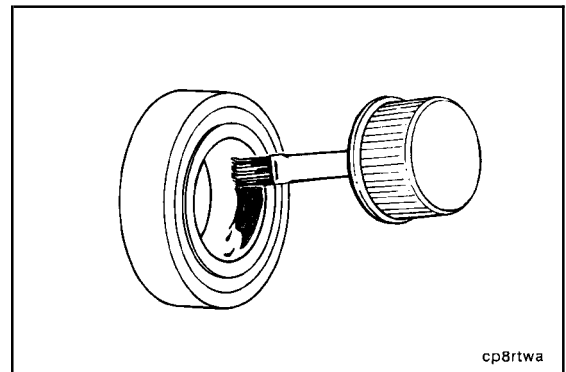

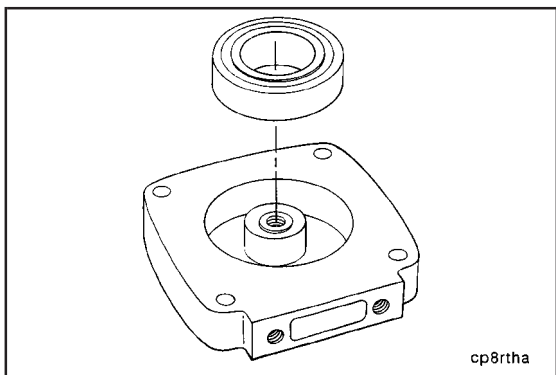

Slide the exhaust valve retainer over the valve plate. Make sure that the end of the retainer with the groove faces upward.

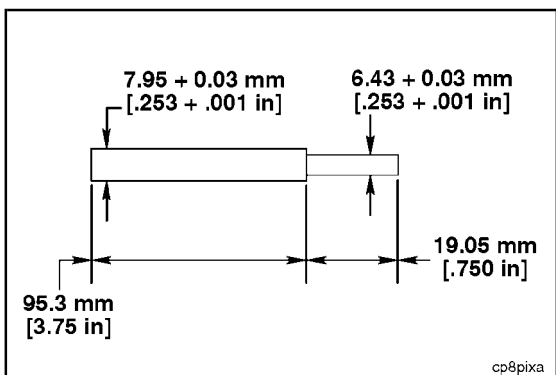

Fabricate or reuse the four guide pin tools.

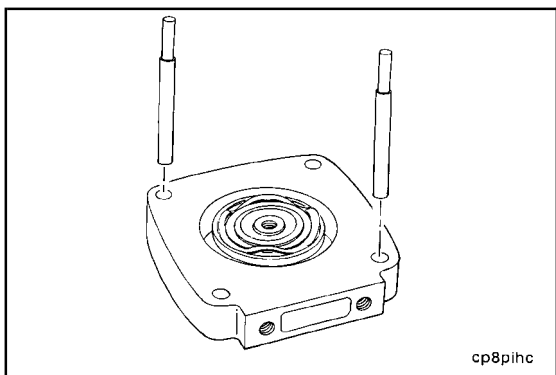

Insert the larger end of two guide pins in opposite corner holes of the valve plate.

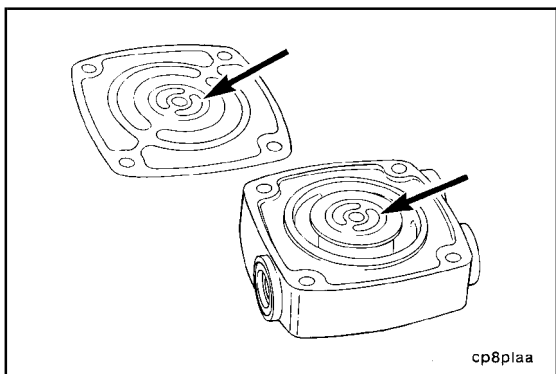

Determine the final orientation of the valve plate (air intake location) and the head (coolant ports in relation to air inlet or manifold location). Align the kidney-shaped slots in the head with the kidney-shaped slots in the gasket.

If orientation marks were made before disassembly, use them.

**B3.9 and B5.9 Series Engines**  
**Section 12 - Compressed Air System - Group 12**

Install the head gasket onto the guide pins (either side up, but with correct slot orientation). Install the head onto the guide pins with the kidney-shaped slots aligned and toward the valve plate. Install the cover gasket over the guide pins.

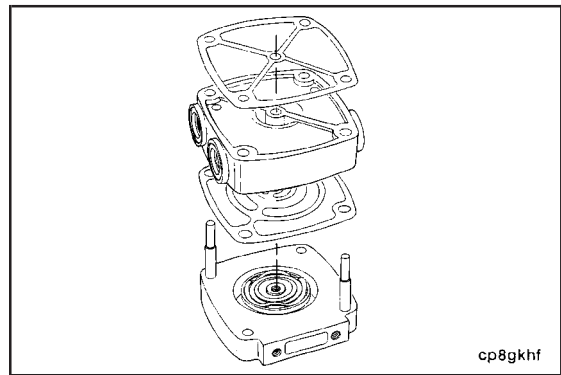

cp8gkhf

Assemble the cover.

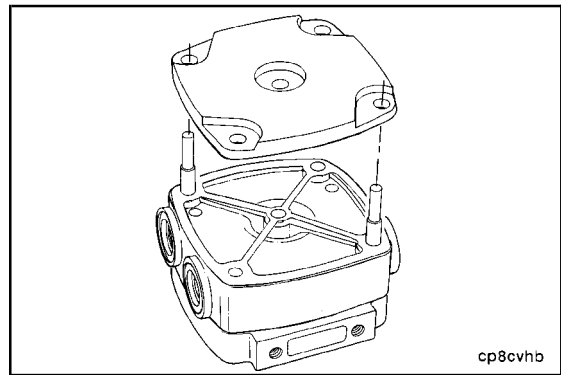

cp8cvhb

Install the shorter capscrew with washer, if initially installed, through the center hole.

**Torque Value:** 14 N•m [124 in-lb]

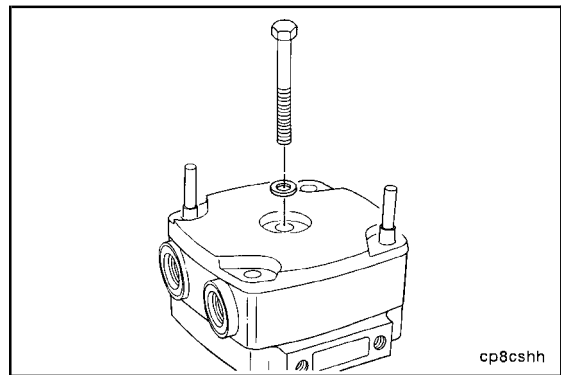

cp8cshh

Place the remaining two guide pins in the crankcase head capscrew holes (that will **not** interfere with the guide pins already in the head assembly).

Install the valve plate gasket.

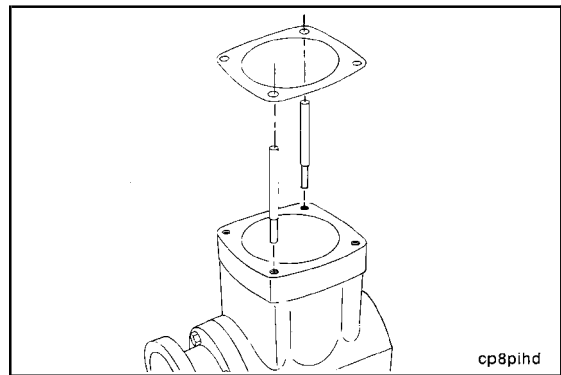

cp8pihd

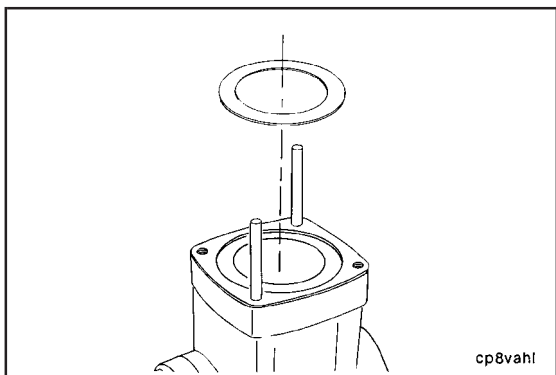

Carefully place the intake valve on the crankcase, located by the valve plate gasket. Do **not** allow the valve to overlap the gasket.

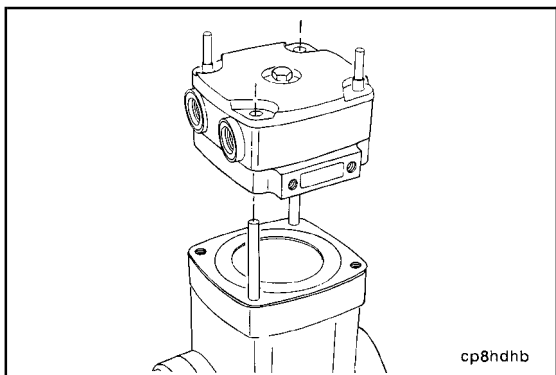

Install the head assembly over the guide pins. Be careful **not** to disturb the location of the intake valve. The compressor will **not** work if the valve overlaps the gasket and is pinched.

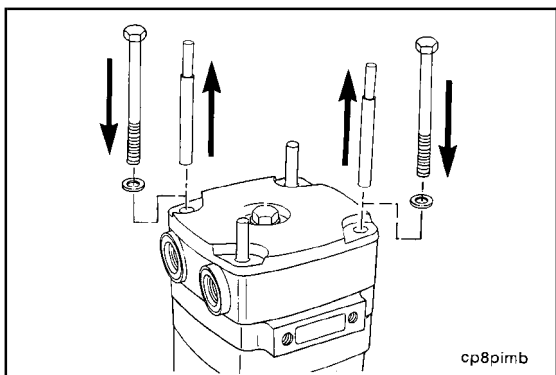

Carefully remove two of the guide pins and replace with two head capscrews and washers, if initially installed.

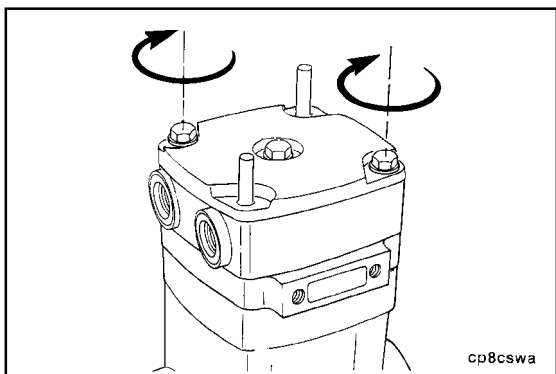

Tighten the two head capscrews.  
**Torque Value:** 14 N•m [124 in-lb]



**B3.9 and B5.9 Series Engines**  
**Section 12 - Compressed Air System - Group 12**

Remove the remaining two pins and replace with two head capscrews and washers, if initially installed.

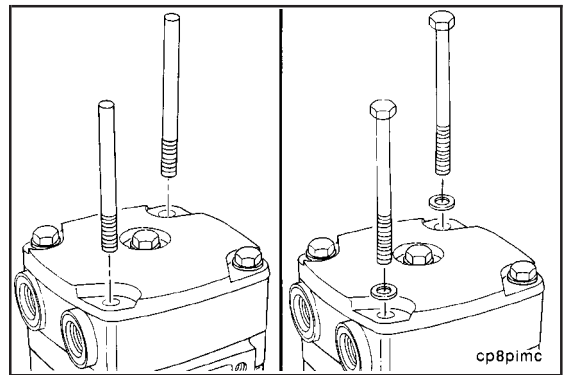

Tighten all five capscrews in the proper sequence.

**Torque Value:** 28 N•m [21 ft-lb]

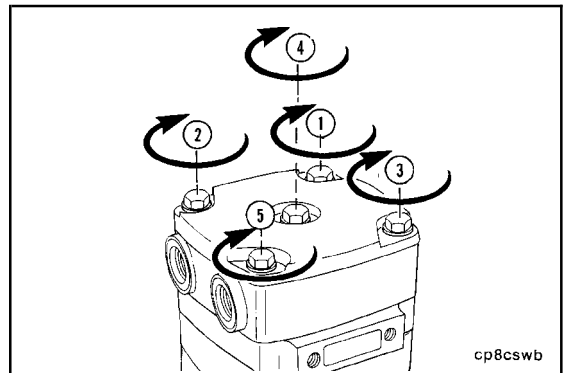

Install the new rectangular v-seal into the unloader body.

**NOTE:** The seal **must** be installed with the grooved side up.

Liberaly lubricate the unloader valve bore above and below the rectangular ring seal with high-temperature grease (Accrolube Lubrication Teflon™ grease or equivalent).

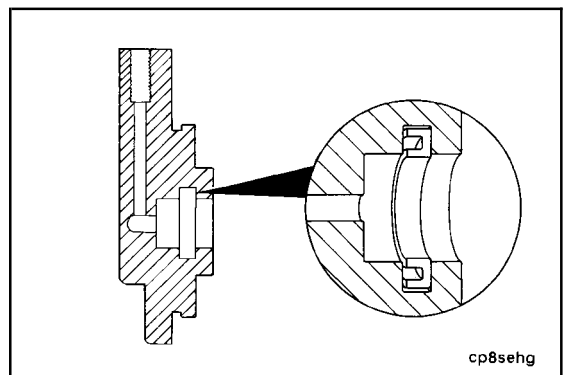

Install a new o-ring seal on the unloader valve body.

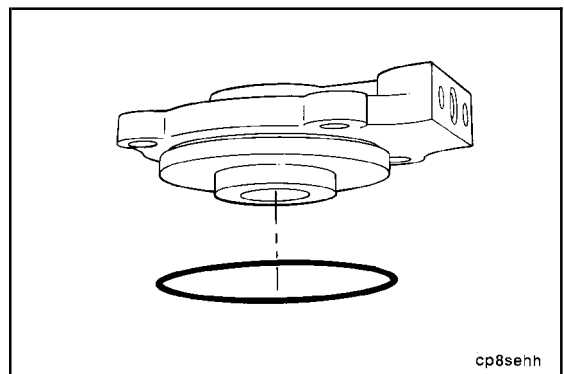

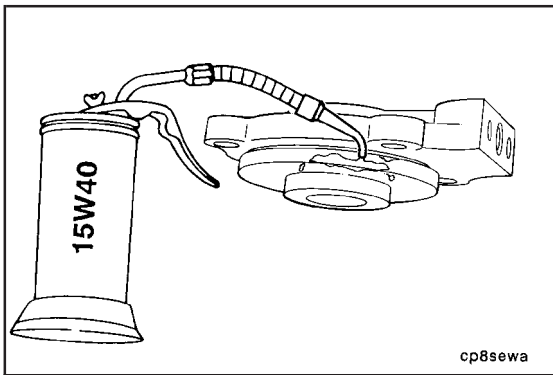

Use clean lubricating engine oil or Accrolube lubrication Teflon™ grease, or equivalent, to lubricate the seal.

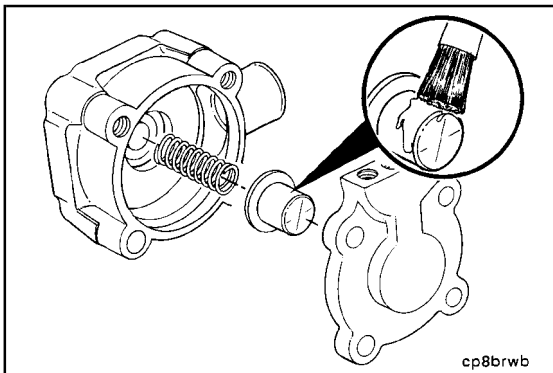

Liberalily lubricate the unloader valve body bore and unloader cap with high temperature grease (Accrolube lubrication Teflon™ grease or the equivalent).



Install the unloader cap.  
Install the unloader spring.

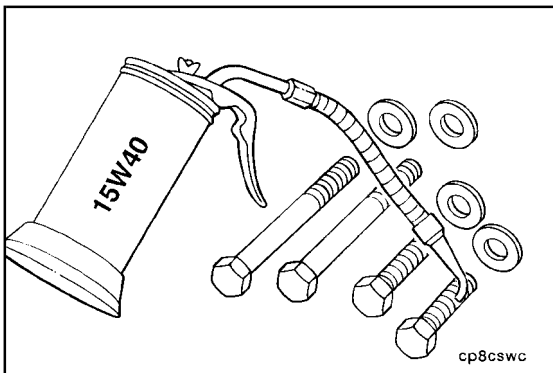

Lubricate the unloader screw threads and under the head with clean lubricating engine oil before installation.

**NOTE:** The two unloader body screws **must not** be used to attach any brackets.

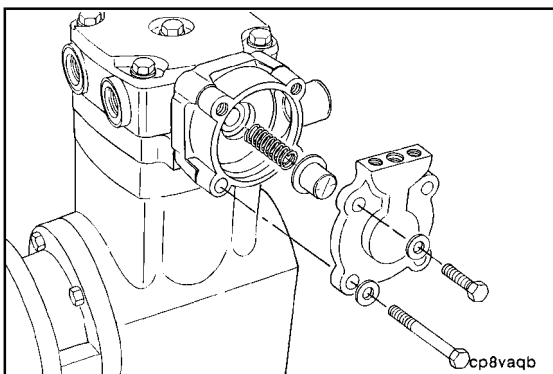

Assemble the unloader components, and attach the unloader assembly to the valve plate with the four capscrews and washers.



**NOTE:** The longer capscrews are used to mount the manifold to the air compressor.

**Torque Value:** 27 N•m [20 ft-lb]

# Section 13 - Electrical Equipment - Group 13

## Section Contents

	Page
<b>Alternator</b> .....	13-12
Initial Check .....	13-12
Install .....	13-17
Preparatory.....	13-15
Remove.....	13-15
Test .....	13-16
<b>Alternator Bracket</b> .....	13-18
Install .....	13-18
Remove.....	13-18
<b>Alternator Pulley</b> .....	13-18
Install .....	13-19
Preparatory.....	13-18
Remove.....	13-18
<b>Batteries</b> .....	13-19
Initial Check .....	13-19
<b>Battery Cables and Connections</b> .....	13-23
Initial Check .....	13-23
<b>Electrical Equipment - General Information</b> .....	13-2
<b>Electronic Wiring Diagrams</b> .....	13-4
<b>Service Tools</b> .....	13-1
Electrical Equipment.....	13-1
<b>Specifications</b> .....	13-8
Batteries (Specific Gravity) .....	13-10
Electrical System .....	13-8
<b>Starter Magnetic Switch</b> .....	13-24
Initial Check .....	13-24
Resistance Check.....	13-25
Voltage Check .....	13-26
<b>Starter Solenoid</b> .....	13-28
Initial Check .....	13-28
Voltage Check .....	13-29
<b>Starter Switch</b> .....	13-27
Initial Check .....	13-27
<b>Starting Motor</b> .....	13-34
Install .....	13-36
Preparatory.....	13-34
Remove.....	13-34
Rotation Check.....	13-37
Test .....	13-35

**THIS PAGE LEFT INTENTIONALLY BLANK**

## Service Tools Electrical Equipment

The following special tools are recommended to perform procedures in this section. The use of these tools is shown in the appropriate procedure. These tools can be purchased from your local Cummins Authorized Repair Location.

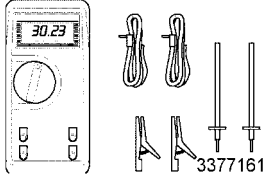
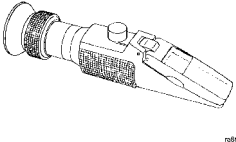
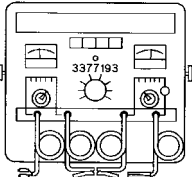
Tool No.	Tool Description	Tool Illustration
3377161	<p><b>Digital Multimeter</b></p> <p>Use to measure electrical circuit: Voltage (VDC), resistance (ohms), and current (amps).</p>	
CC-2800	<p><b>Refractometer</b></p> <p>The Fleetguard® refractometer is used to check the charge condition of a conventional battery.</p>	
3377193	<p><b>System Analyzer/Battery Tester</b></p> <p>Use to test the output amperage of maintenance-free or conventional vent cap batteries.</p>	

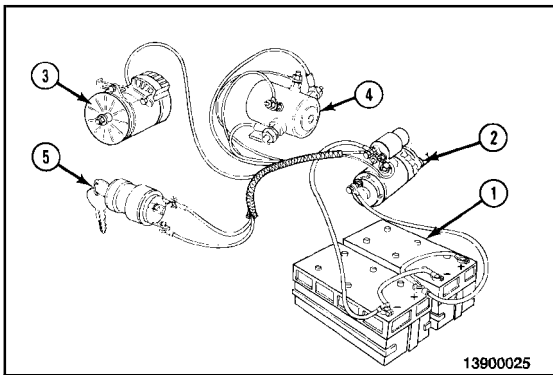

## Electrical Equipment - General Information

### ⚠ WARNING ⚠

Batteries can emit explosive gases. To avoid personal injury, always ventilate the compartment before servicing the batteries. To avoid arcing, remove the negative (-) battery cable first, and attach the negative (-) battery cable last.

### ⚠ WARNING ⚠

To avoid personal injury, keep hands, long hair, jewelry, and loose-fitting or torn clothing away from fans and other moving parts.

The basic electrical system consists of:

- Batteries (1)
- A starter motor (2)
- An alternator (3)
- A magnetic switch (4)
- An ignition switch (5)
- All necessary wiring.

All components **must** be carefully matched.

The rotary injection pump uses an electrical fuel shutoff valve. The in-line injection pump uses an electrically activated solenoid shutdown system. The function of the valve is discussed in the fuel system section.

The engine will have temperature and oil pressure sensors connected to indicators or wired for automatic shutdown. The engine can also be fitted with a block heater, oil pan heater, or intake manifold air heater.

**NOTE:** When troubleshooting a Cummins B Series generator set, refer to the Operation and Maintenance Manual, B Series Engines, Bulletin No. 3810205.

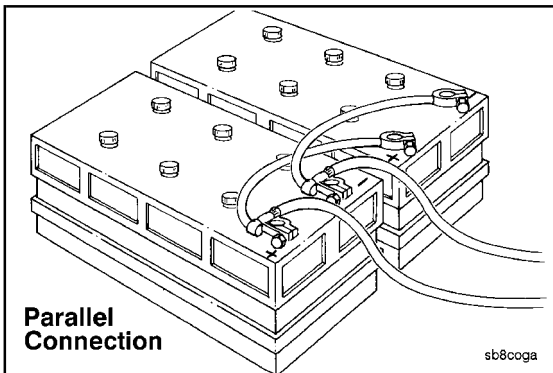

The accompanying illustrations show typical parallel and series connections:

- Parallel connection.

- Series connection.

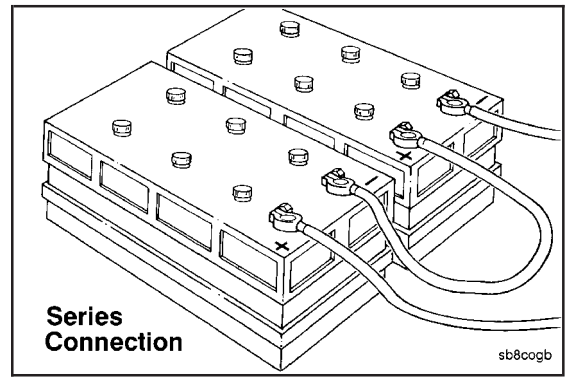

### Electronic Wiring Diagrams

#### Delco Remy Model 27MT/28MT Starting Motor

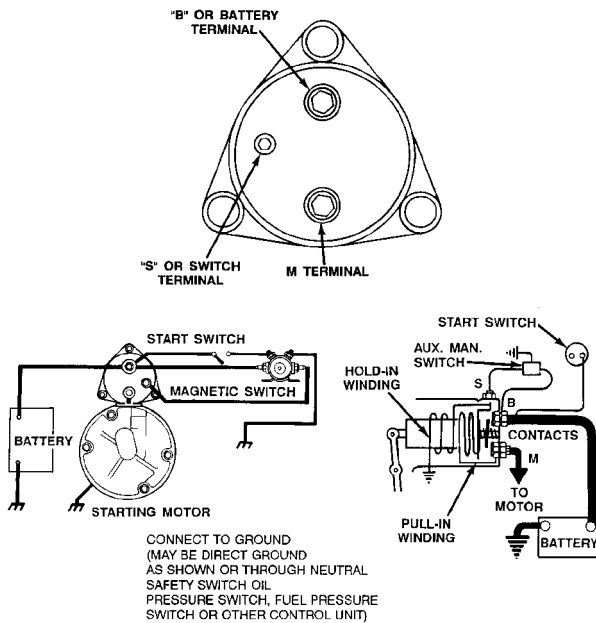

13900060



Nippondenso "R" Type Starting Motor

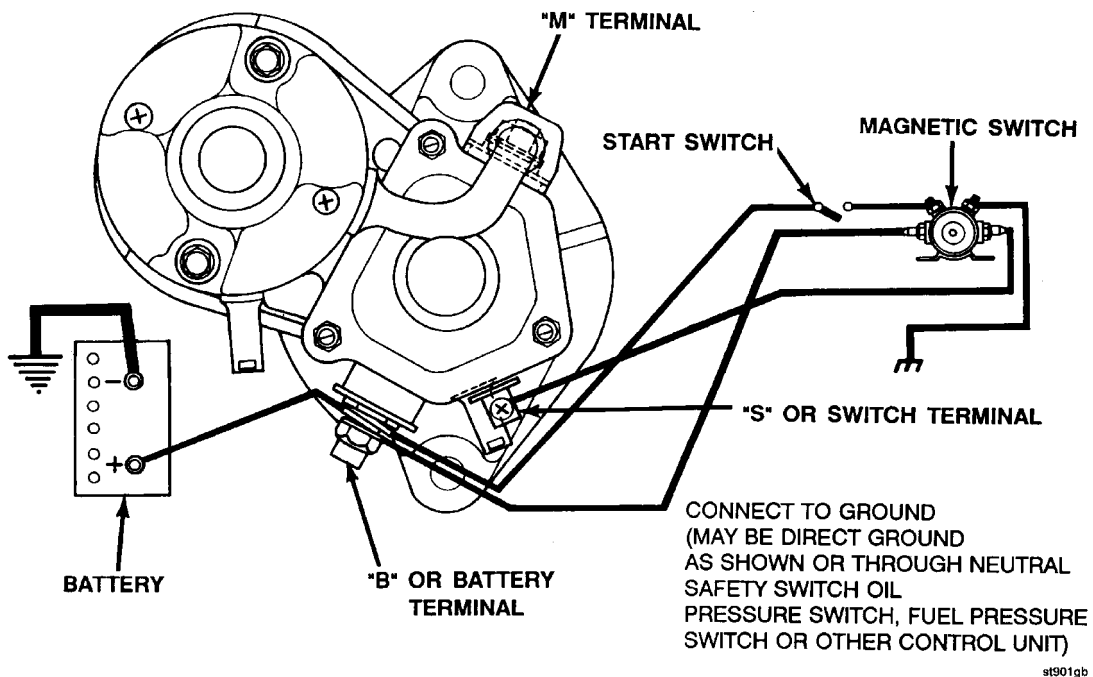

Basic Wiring Circuit (with auxiliary magnetic switch)

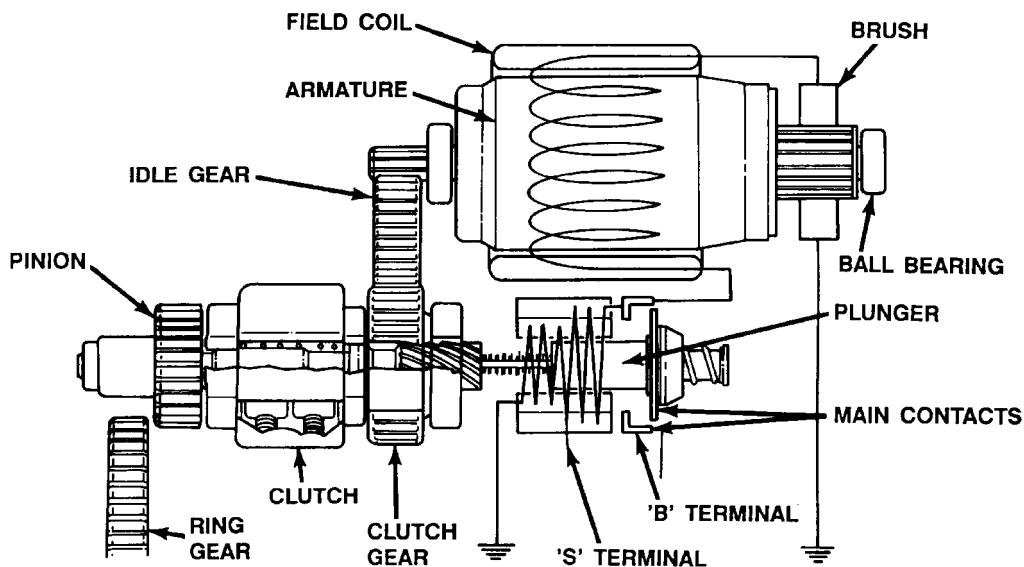

st901gc

Starter Solenoid Wiring Circuit

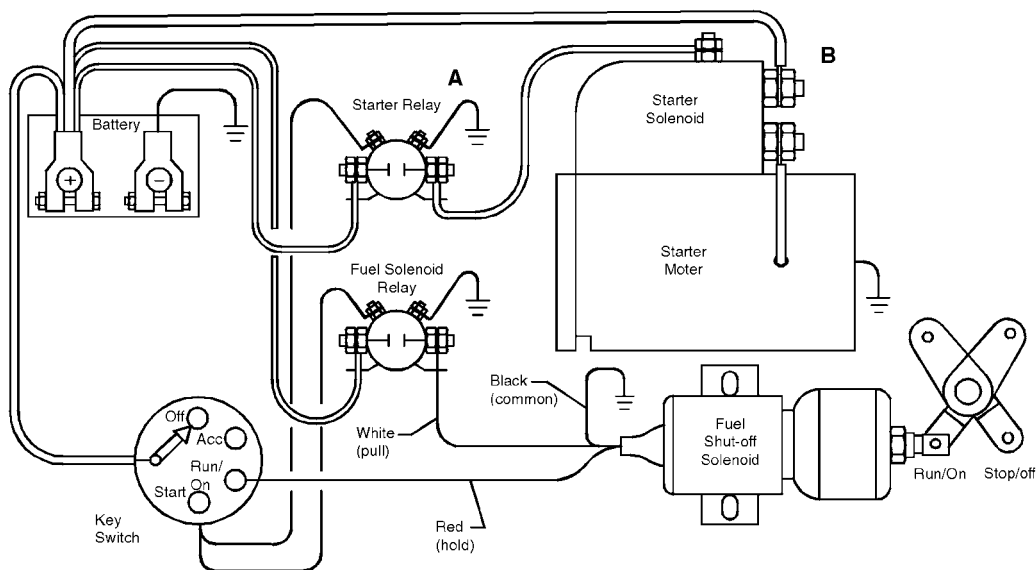

13900046

Typical Bosch® K1 Charging System Circuit

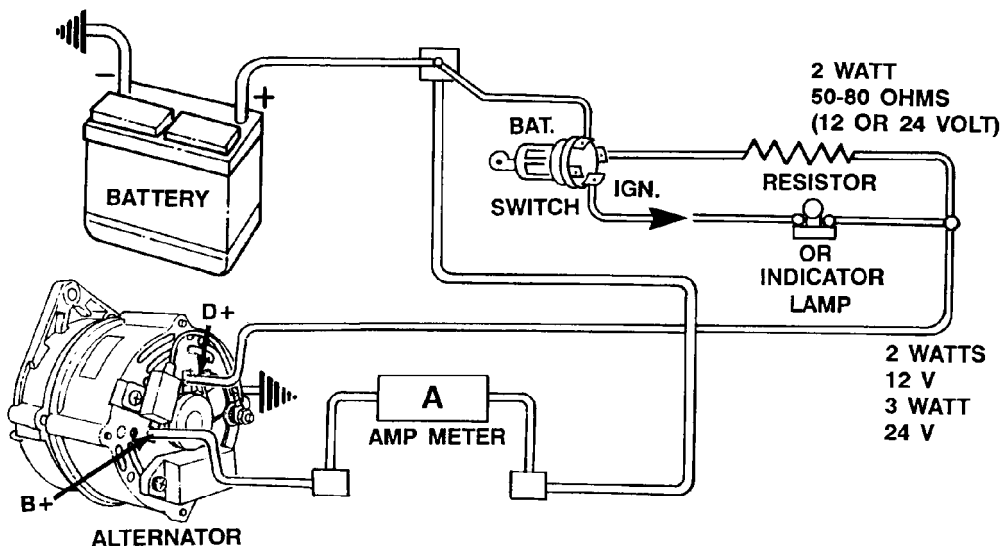

13900059

Typical Delco® Charging System Circuit

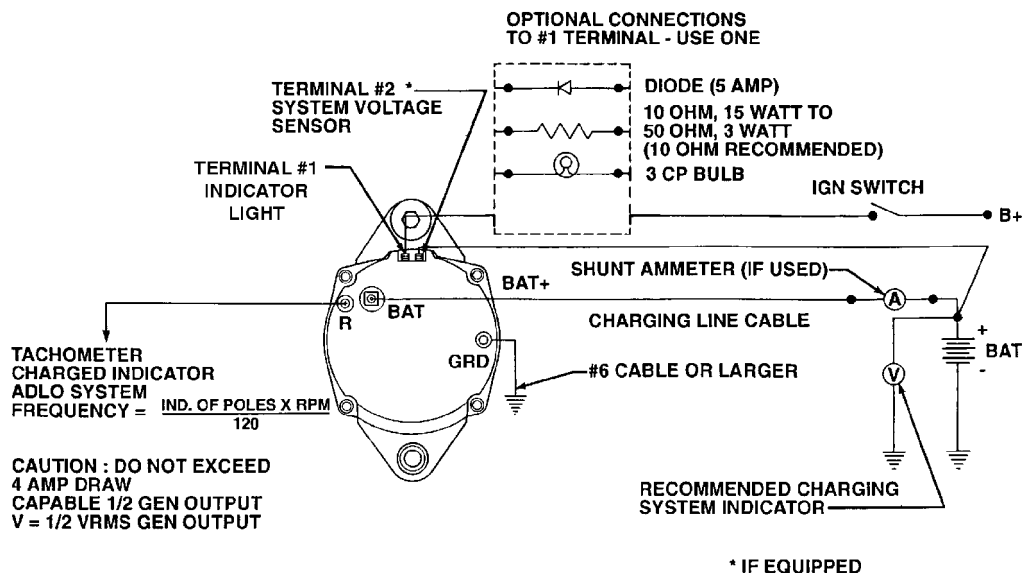

13900058

## Specifications

### Electrical System

#### Electrical System Data (automotive)

	B3.9	B5.9
<b>Minimum Recommended Battery Capacity @ -18°C [0°F]</b>		
<b>With Light Accessories*</b>		
12-VDC Starter	625CCA	800CCA
24-VDC Starter	400CCA	400CCA
<b>With Heavy Accessories**</b>		
12-VDC Starter	800CCA	950CCA
24-VDC Starter	400CCA	475CCA
<b>Maximum Allowable Resistance of Starting Circuit</b>		
With 12-VDC Starter - Ohms	0.0012	0.0012
With 24-VDC Starter - Ohms	0.0020	0.0020

\*Typical light accessories include alternator, small steering pump, and disengaged clutch.

\*\*Typical heavy accessories include hydraulic pump and torque converter.

4B Electrical System Data (nonautomotive)

	4B3.9	4BT3.9	4BTA3.9
<b>Minimum Recommended Battery Capacity @ -18°C [0°F]</b>			
<b>With Light Accessories*</b>			
12-VDC Starter	625CCA	625CCA	625CCA
24-VDC Starter	312CCA	400CCA	400CCA
<b>With Heavy Accessories**</b>			
12-VDC Starter	800CCA	800CCA	800CCA
24-VDC Starter	400CCA	400CCA	400CCA
<b>Maximum Allowable Resistance of Starting Circuit</b>			
With 12-VDC Starter - Ohms	0.0012	0.0012	0.0012
With 24-VDC Starter - Ohms	0.0020	0.0020	0.0020

\* Typical light accessories include alternator, small steering pump, and disengaged clutch.

\*\* Typical heavy accessories include hydraulic pump and torque converter.

6B Electrical System Data (nonautomotive)

	6B5.9	6BT5.9	6BTA5.9
<b>Minimum Recommended Battery Capacity @ -18°C [0°F]</b>			
<b>With Light Accessories*</b>			
12-VDC Starter	800CCA	800CCA	800CCA
24-VDC Starter	400CCA	400CCA	400CCA
<b>With Heavy Accessories**</b>			
12-VDC Starter	950CCA	950CCA	950CCA
24-VDC Starter	475CCA	475CCA	475CCA
<b>Maximum Allowable Resistance of Starting Circuit</b>			
With 12-VDC Starter - Ohms	0.0012	0.0012	0.0012
With 24-VDC Starter - Ohms	0.0020	0.0020	0.0020

\* Typical light accessories include alternator, small steering pump, and disengaged clutch.

\*\* Typical heavy accessories include hydraulic pump and torque converter.

**Batteries (Specific Gravity)**

Specific Gravity at 27°C [80°F]	State of Charge
1.260 to 1.280	100%
1.230 to 1.250	75%
1.200 to 1.220	50%
1.170 to 1.190	25%
1.110 to 1.130	Discharged

**Battery Cable Specifications**

Cable Size Gauge	Nominal Resistance in Ohms		Maximum Total Length (sum of both cables)			
	Per Meter	Per Foot	12 VDC		24 VDC	
			Meter	Feet	Meter	Feet
4	0.000984	0.00030	NR*	NR*	2.03	6.7
2	0.000615	0.000188	1.63	5.3	3.26	10.6
1	0.000492	0.000150	2.03	6.7	4.06	13.4
0	0.000386	0.000118	2.59	8.5	5.18	17.0
00	0.000292	0.000090	3.43	11.3	6.86	22.6
000	0.000232	0.000071	4.32	14.2	8.64	28.4

\* Not recommended

Wiring Size Recommendations - Starter and Fuel Solenoid

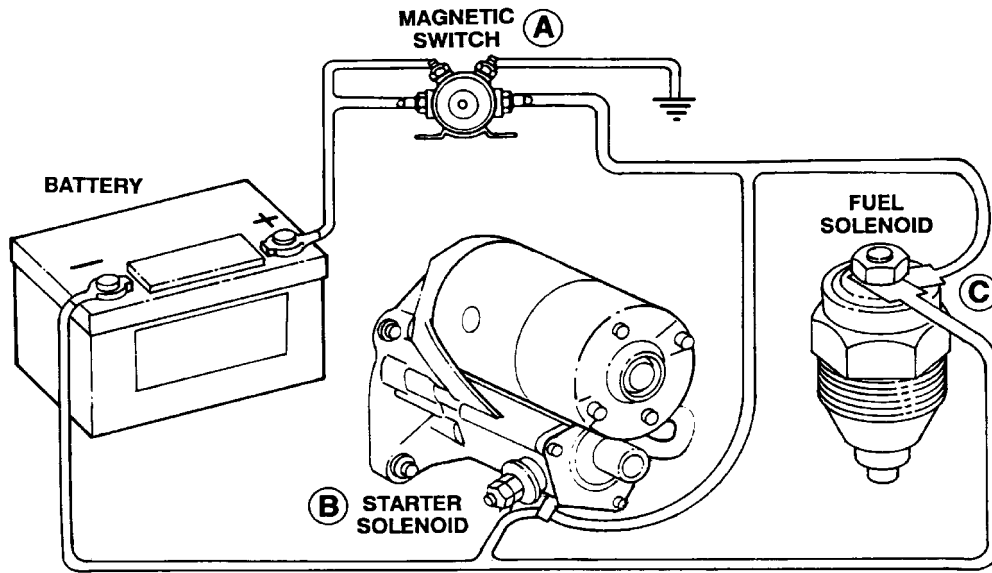

ea900gc

Recommended Wire Gauge Table (Values in table are AWG. size for 12/24-VDC systems)			
Wire Length in Circuit	Battery to A	A to B	A to C
0.91 m [3 ft]	10/14	12/14	14/16
1.21 m [4 ft]	10/12	10/14	14/16
1.52 m [5 ft]	8/10	10/12	14/16
2.74 m [9 ft]	6/8	8/10	12/14
5.49 m [18 ft]	4/6	6/8	8/10

Wire length in circuit means total length in each individual circuit, e.g., Battery to A equals one circuit.

For example, in a 12-VDC circuit:

Battery to A = 1.52 m [5 ft]; gauge required = 8 gauge

A to B = 1.52 m [5 ft]; gauge required = 10 gauge

A to C = 2.74 m [9 ft]; gauge required = 12 gauge.

If the system is double-pole wiring (no frame ground), then the fuel and starter solenoid circuit lengths would include the return cable run to the battery negative (-) post.

### Alternator (013-001)

#### Initial Check (013-001-001)

The terminals on the alternator are shown in this illustration. The "R" (Delco) and "W" (Bosch) terminals provide one-half system voltage and are used to operate accessories, such as the tachometer, on generator sets.

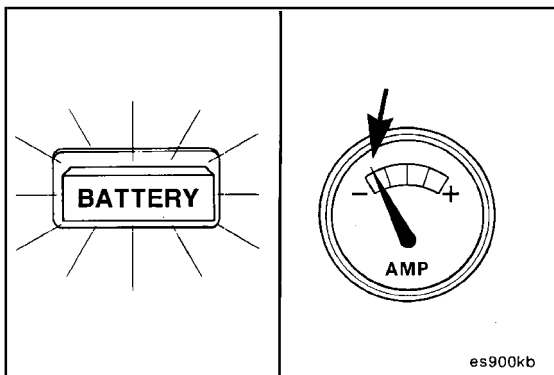
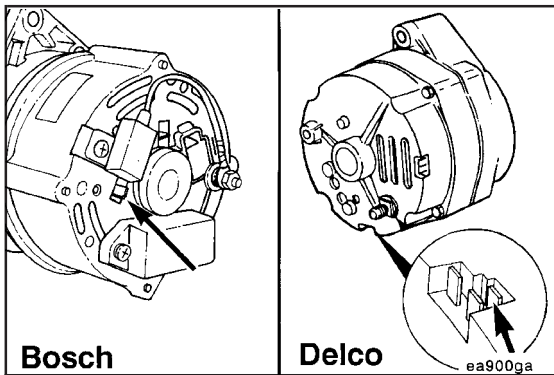

Trouble with the charging system can be indicated by the indicator lamp or ammeter.

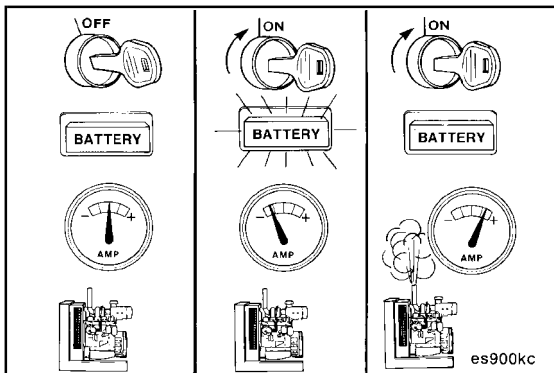

#### Abnormal Indicator Lamp Operation

Check the indicator lamp for normal operation as shown below.

Engine	Switch	Lamp	Ammeter
Stopped	Off	Off	0
Stopped	On	On	-
Running	On	Off	+

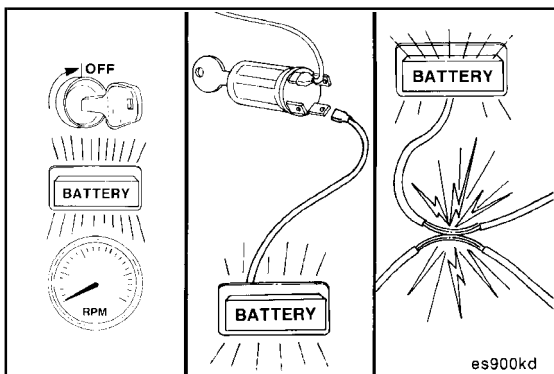

#### Switch Off, Lamp On, Engine Stopped

Disconnect the lamp lead at the ignition switch. If the lamp stays on, there is a short in a positive wire on the ignition side of the lamp.



If the lamp goes out, there is a short in the switch.

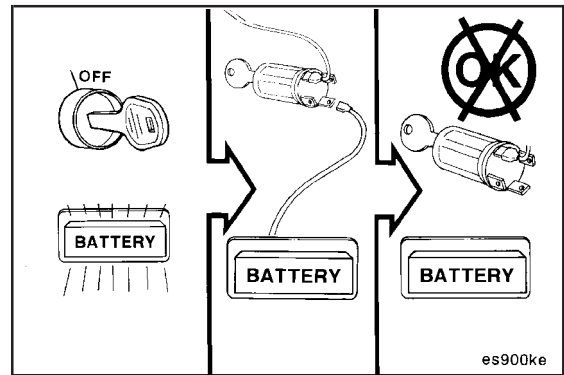

**Switch On, Lamp Off, Engine Stopped**

This condition can be caused by an open circuit. To determine where an open circuit exists, check for a blown fuse, a burned-out bulb, defective bulb socket, or an open circuit in No. 1 or "D +" lead circuit between alternator and ignition switch.

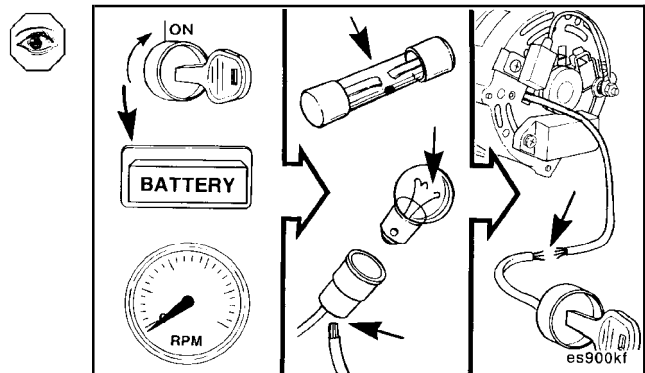

**Switch On, Lamp On, Engine Running**

Check the drive belt and alternator pulley to be sure the alternator is rotating.

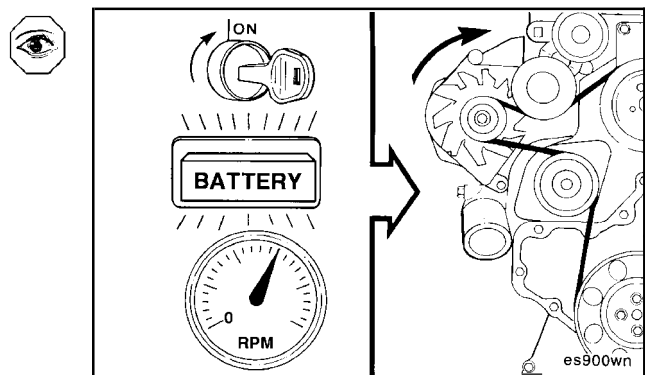

Disconnect the lead to terminals No. 1 and No. 2 (Delco) or D+ (Bosch® K1). If the lamp stays on, there is a short to ground on the alternator side of the lamp.

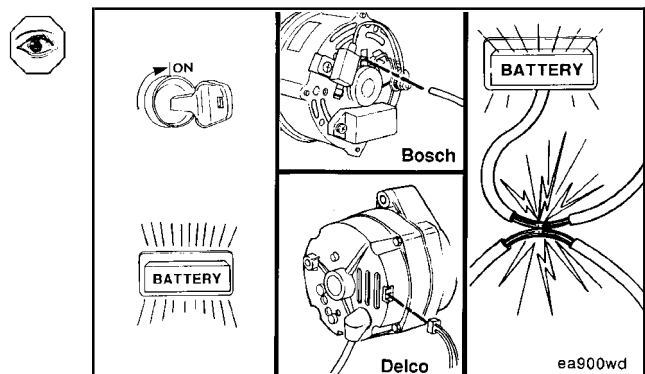

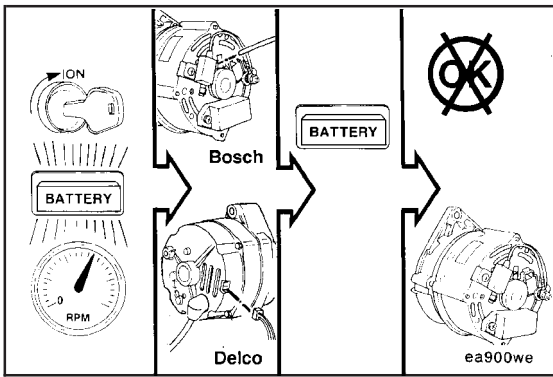

If the lamp goes out, replace the alternator.

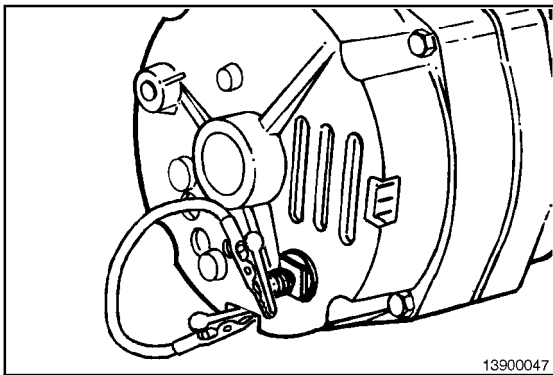

**Abnormal Charging System Operation**

To verify a Delco® alternator is operational, momentarily touch a jumper lead between the battery terminal "B+" and "R" or "I" terminals on the alternator while the alternator is spinning. This will turn the alternator on if it is operational. Test the alternator's output. Replace alternator if necessary.

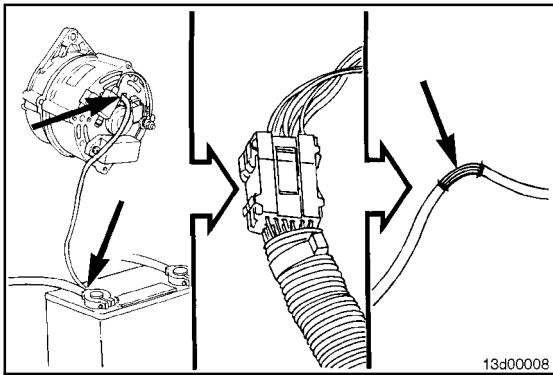

Check the battery and all wiring connections.



Inspect the wiring for defects. Check all connections for tightness and cleanliness, including the slip connectors at the alternator and firewall, and connections at the battery.

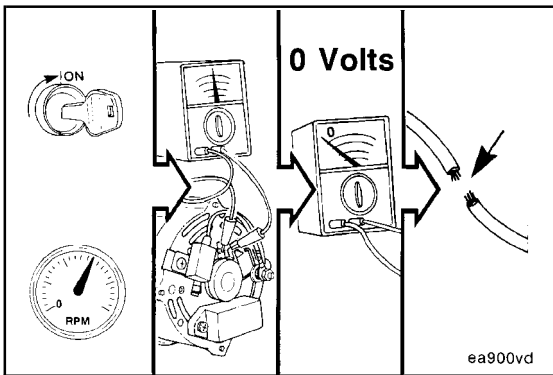

With ignition switch on and all wiring harness leads connected, connect a multimeter from:

- Alternator "BAT" (Delco® 15SI) "B+" (Bosch® K1) terminal to ground
- Alternator No. 1 (Delco® 15SI) to ground
- Alternator No. 2 (Delco® 15SI) to ground
- Alternator D+ (Bosch® K1) to ground.

A zero reading indicates an open circuit between the alternator connections and the battery.

Locate and repair the open circuit.

**B3.9 and B5.9 Series Engines  
Section 13 - Electrical Equipment - Group 13**

With all accessories turned off, connect a multimeter across the battery. Operate engine at moderate speed.

If voltage is 15.5 VDC or more on a 12-VDC system, remove the alternator for repair. The limit for 24-VDC systems is 28 VDC.

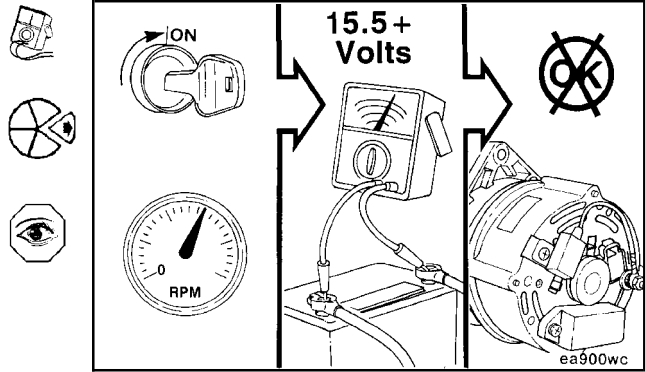

**Preparatory (013-001-000)**



**WARNING**

Batteries can emit explosive gases. To avoid personal injury, always ventilate the compartment before servicing the batteries. To avoid arcing, remove the negative (-) battery cable first and attach the negative (-) battery cable last.

- Disconnect the ground cable from the battery terminal.
- Remove the drive belt from the alternator pulley. Refer to Procedure 008-002.

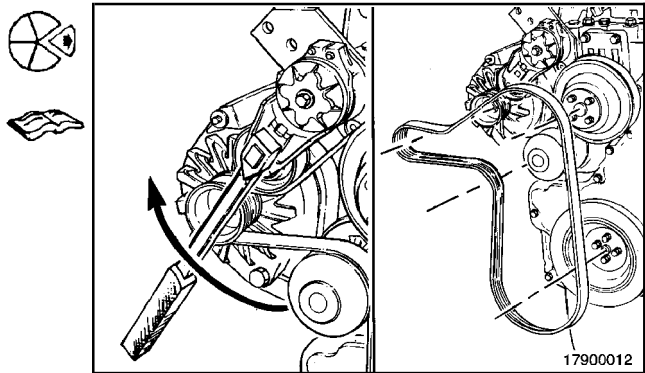

**Remove (013-001-002)**

**11 mm**

- Remove and tag all wires, and complete the following steps.

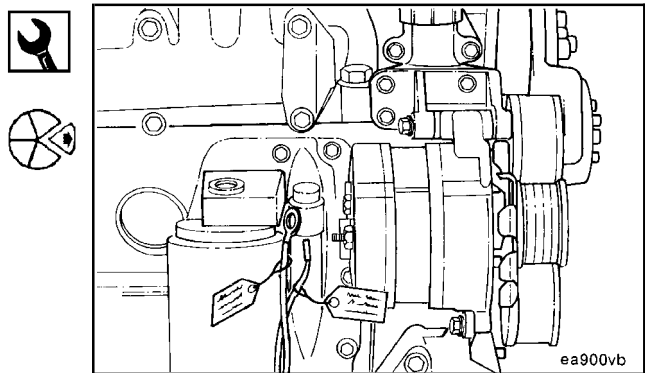

**13 mm**

Remove the alternator link capscrew.

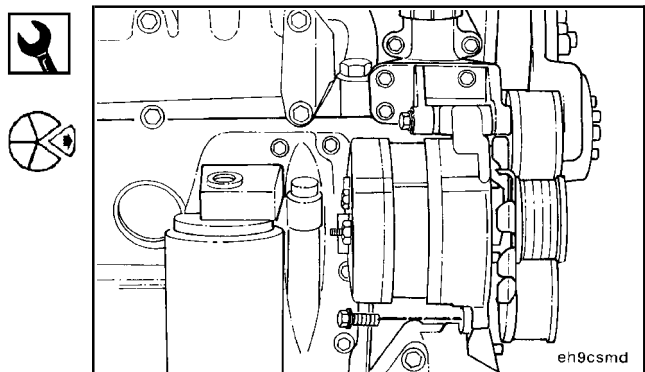

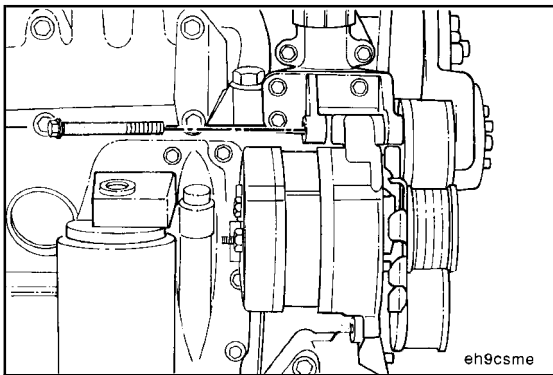

16 mm

Remove the alternator mounting capscrew.

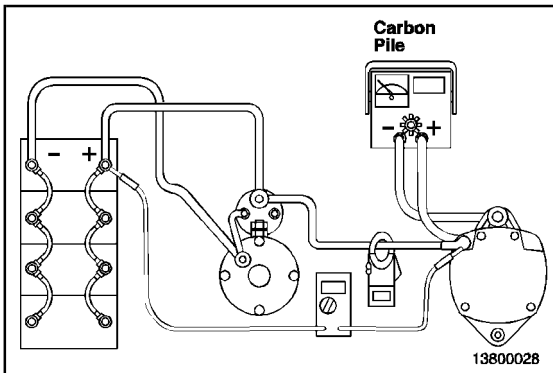

**Test (013-001-012)**

**⚠ WARNING ⚠**

Batteries can emit explosive gases. To avoid personal injury, always ventilate the compartment before servicing the batteries. To avoid arcing, remove the negative (-) battery cable first and attach the negative (-) battery cable last.

**⚠ WARNING ⚠**

Acid is extremely dangerous and can damage the machinery and can also cause serious burns. Always provide a tank of strong soda water as a neutralizing agent when servicing the batteries. Wear goggles and protective clothing to avoid serious bodily injury.

Attach the carbon pile and clip-on ammeter as shown. Adjust the load from the carbon pile tester to the rated performance of the alternator.

Measure the voltage drop in both the positive and negative circuits. Add these together, and compare the sum to the table.

System Voltage	Maximum Voltage Drop
12 VDC	0.5 VDC
24 VDC	1.0 VDC

Repair or replace the wiring as required to meet the above specifications.

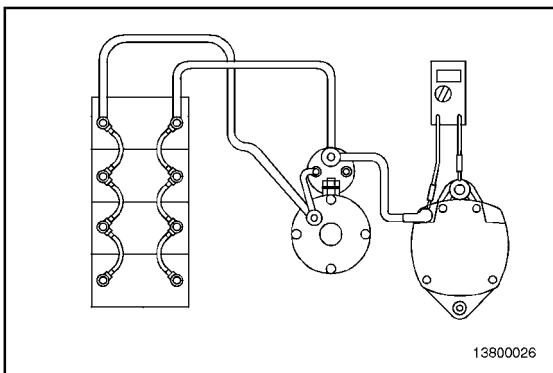

**Alternator Voltage Output Check**

**Digital Multimeter, Part No. 3377161**

Attach the multimeter to the alternator as shown in the illustration.

With the batteries in a fully charged condition and all the accessories off, start the engine, and run it at high idle. Allow time for the voltage to stabilize before taking any readings.

Measure the alternator output voltage.

System Voltage	Maximum Output Voltage Limit
12 VDC	15.5 VDC
24 VDC	31 VDC

Repair or replace the alternator or regulator if the voltage limit exceeds the value in the table.

Refer to the OEM specifications for minimum voltage output.

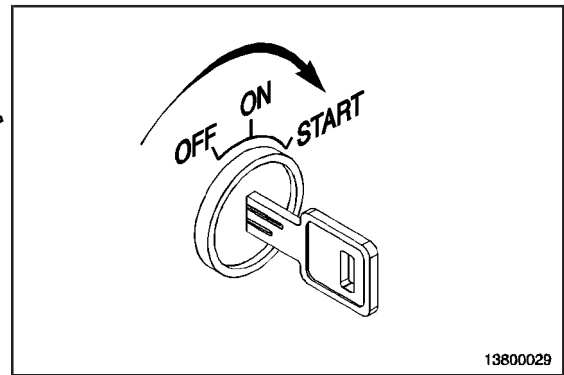

**Alternator Current Output Test**

Attach the carbon pile tester and clamp-on ammeter as shown in illustration.

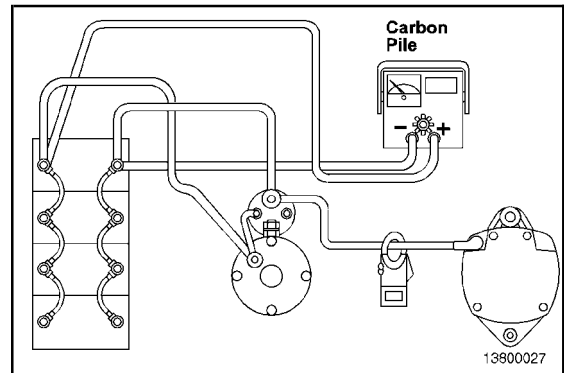

Start the engine, and operate at high idle.

Adjust the carbon pile load to the rated current output of the alternator.

If the alternator output current is **not** within 10 percent of the rated output, repair or replace the alternator.

**NOTE:** The alternator output is directly related to the speed the alternator is turning. A slipping alternator drive belt can result in an incorrect output reading.

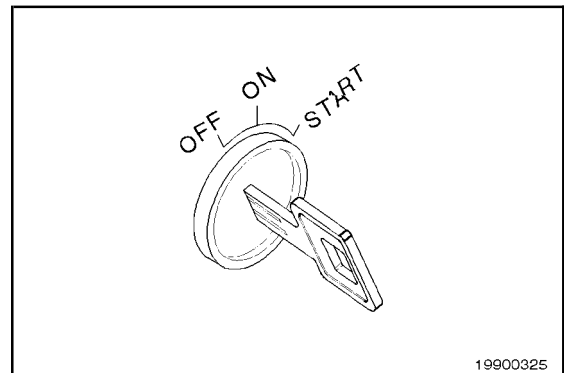

**Install (013-001-026)**

To assemble the alternator, the alternator mounting components **must** be tightened in the following sequence:

1. Alternator-to-alternator-bracket capscrew
2. Lower brace-to-alternator capscrew
3. Lower alternator-brace-to-water-pump capscrew
4. Water-inlet-to-block capscrews.

**NOTE:** Wrench size and torque value are determined by the make and model of alternator. Refer to the Engine Component Torque Values in the specification section.

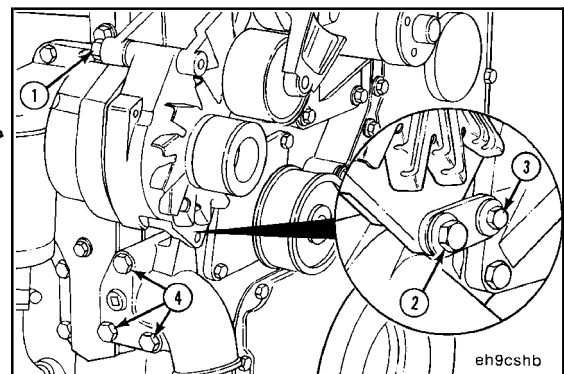

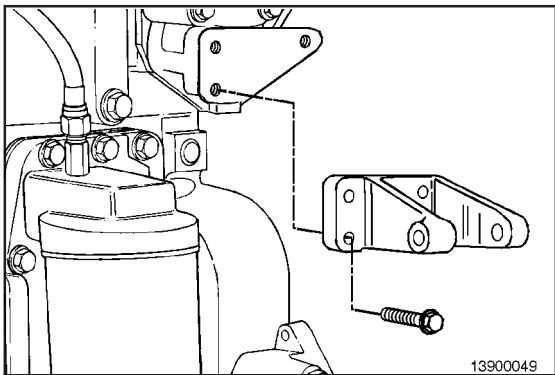

**Alternator Bracket (013-003)**

**Remove (013-003-002)**



Remove alternator. Refer to Procedure 013-001.

Remove alternator bracket mounting capscrews and bracket. Refer to Procedure 013-003.

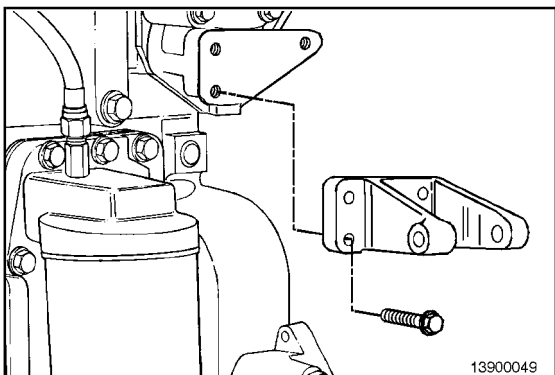

**Install (013-003-026)**

Install the bracket and bracket mounting capscrews.

**Torque Value:** 24 N•m [18 ft-lb]



Install the alternator. Refer to Procedure 013-001.



**Alternator Pulley (013-006)**

**Preparatory (013-006-000)**



Remove drive belt. Refer to the Procedure 008-002.

Hold the shaft or pulley to prevent turning.

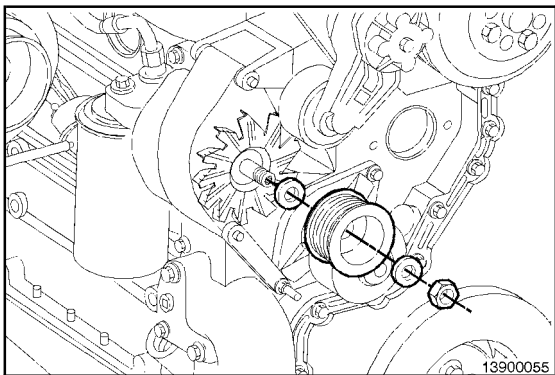

**Remove (013-006-002)**

Remove the alternator pulley.

**Install (013-006-026)**

Install the alternator pulley.

**Torque Value:** 80 N•m [59 ft-lb]

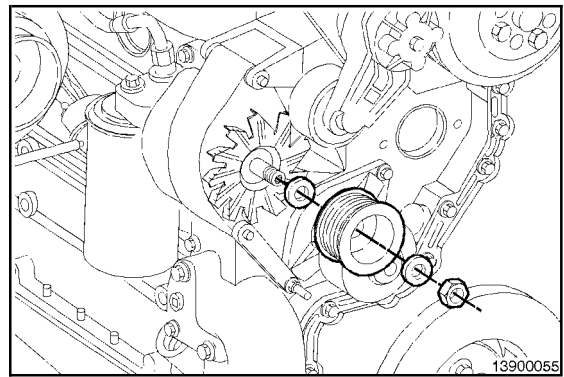

**Batteries (013-007)**

**Initial Check (013-007-001)**



Acid is extremely dangerous and can damage the machinery and can also cause serious burns. Always provide a tank of strong soda water as a neutralizing agent when servicing batteries. Wear goggles and protective clothing to avoid serious bodily injury.



Batteries can emit explosive gases. To avoid injury, always ventilate the compartment before servicing the batteries. To avoid arcing, remove the negative (-) battery cable first and attach the negative (-) battery cable last.

Label and disconnect all battery cables.

Clean corrosion and debris from battery and terminals.

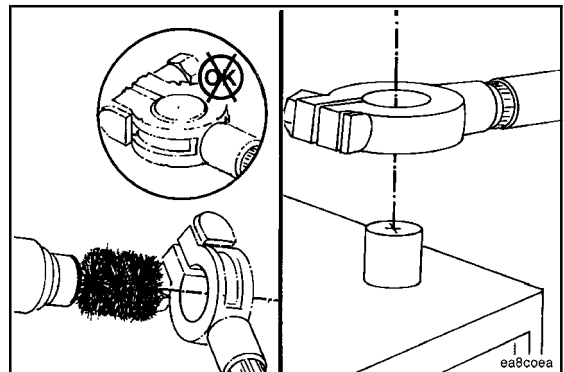
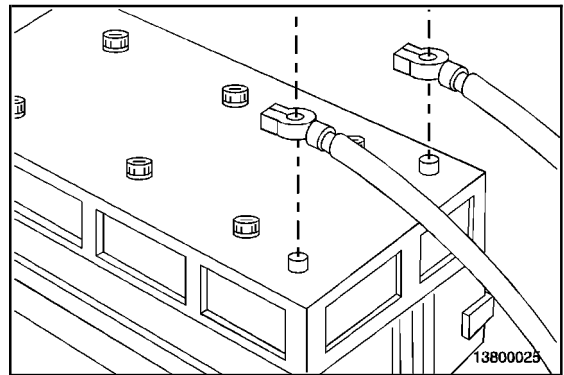

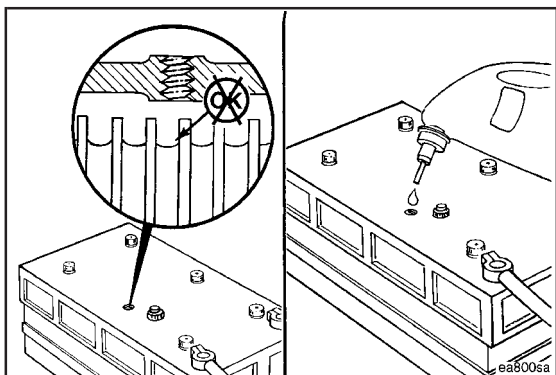

If conventional batteries are used, remove the cell caps or covers, and check the electrolyte level.



**NOTE:** Maintenance-free batteries are sealed and do **not** require the addition of water.

Fill each battery cell with distilled water. Refer to the battery manufacturer's specifications.



**NOTE:** If water is added to the battery it **must** be charged before any testing can be accomplished.

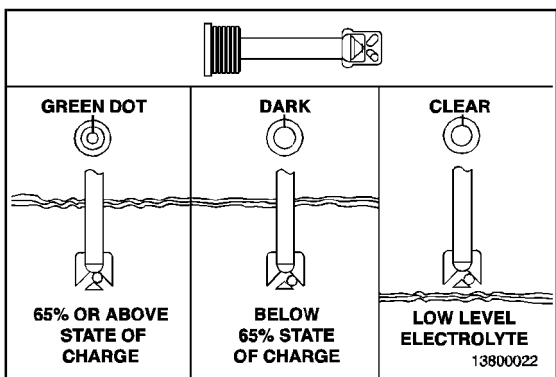

Check the "Eye" on the maintenance-free battery. Refer to the OEM specifications.

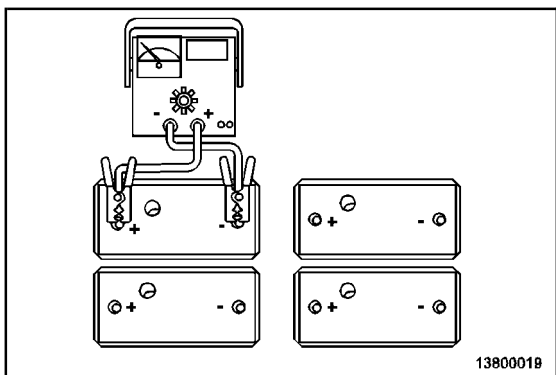

Remove the surface charge by attaching the battery to a 300-amp load for 30 seconds for heavy-duty batteries.

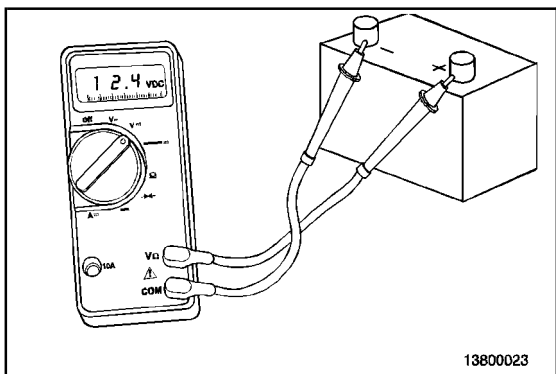

Remove the load, and wait 1 minute; if the battery voltage is greater than or equal to 12.4 VDC, continue testing. If the voltage is below 12.4 VDC, recharge or replace the battery.





Load-test the batteries at 1/2 of the cold cranking amp rating of the battery (rating at -18°C [0°F] for 15 seconds).

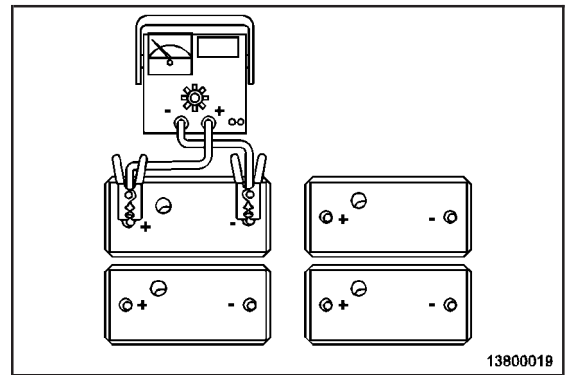

Check the battery voltage, and compare to the table:



Temperature and Voltage Relationship								
Temp (F)	70	60	50	40	30	20	10	0
Temp (C)	21	16	10	4	-1	-7	-12	-18
Min. VDC	9.6	9.5	9.4	9.3	9.1	8.9	8.7	8.5



Turn the load off.

Replace the battery if it does **not** meet the above specifications.

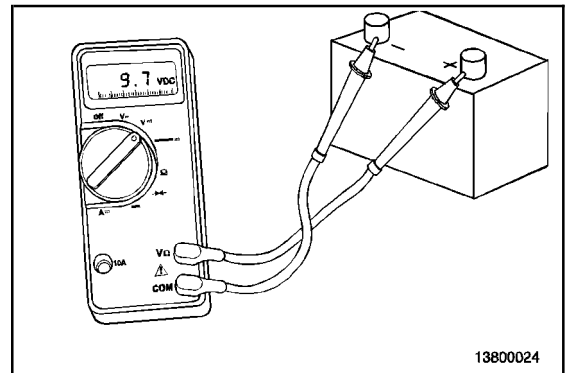

**Refractometer, Part No. CC-2800**

Use the Fleetguard® Refractometer, Part No. CC-2800, to check the specific gravity of the battery electrolyte.



Refer to the battery fluid column in the refractometer to determine the state of charge of each battery cell.



If water has been added to a dry cell, recharge the battery to mix the added water with the existing battery electrolyte to prevent incorrect readings.

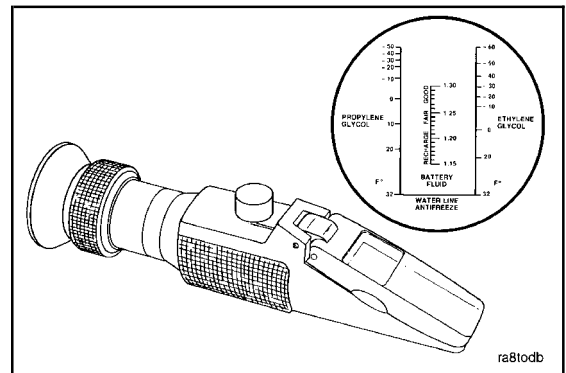

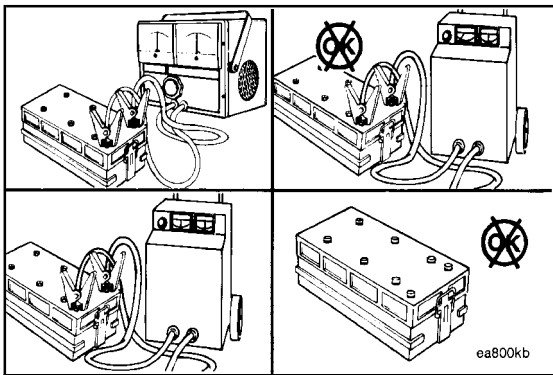

**⚠ CAUTION ⚠**

Do not connect battery charging cables to any electronic control system part. This can damage the electronic control system parts.



**Systems Analyzer/Battery Tester, Part No. 3377193**



Use the systems analyzer/battery tester, Part No. 3377193, to test the output amperage of maintenance-free or conventional vent-cap batteries.

If the output amperage is low, use a battery charger to charge the battery. Refer to the manufacturer's instructions.

Replace the battery if it will **not** charge to the manufacturer's specifications or will **not** maintain a charge.

Refer to the accompanying table to determine the battery state of charge based on the specific-gravity readings.

Battery State of Charge	Specific Gravity @ 27°C [80°F]
100%	1.260 to 1.280
75%	1.230 to 1.250
50%	1.200 to 1.220
25%	1.170 to 1.190
Discharged	1.110 to 1.130

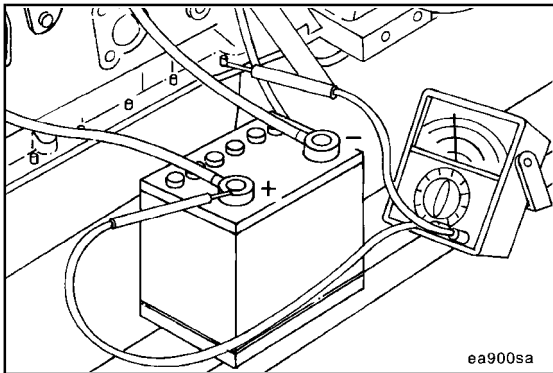

All batteries, including maintenance-free ones, can be checked by measuring the voltage between the positive (+) battery cable and the engine block ground (-). Note the voltage.

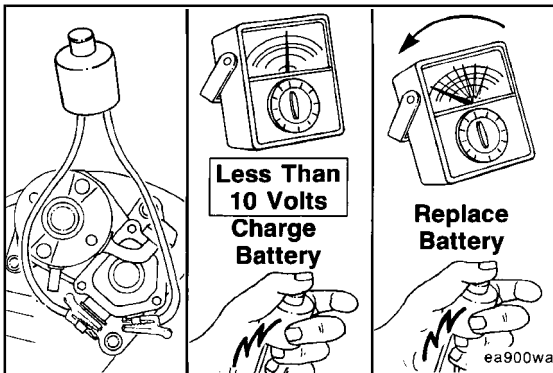

Using a remote start connection, attempt to engage the starter while observing the voltage.

If the voltage reads less than 10 VDC, charge the battery.

If the voltage drops rapidly more than 2 VDC, replace the battery.

**NOTE:** Always connect the negative (-) battery cables last.  
Connect all battery cables.

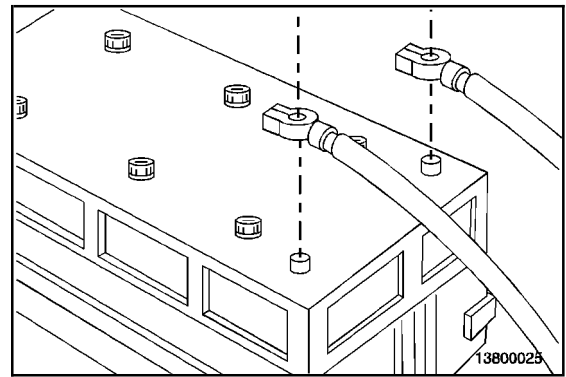

### Battery Cables and Connections (013-009)

#### Initial Check (013-009-001)

##### Cranking Circuit or Battery Cable Test

Attach the carbon pile tester and multimeter. Apply 500 amps of load (250 amps for a 24-VDC system), and measure the positive and negative voltage losses. Add (V1) and (V2) together for a total battery cable voltage drop. The measured voltage drop **must** be less than 0.5 VDC for a 12-VDC system or less than 1 VDC for a 24-VDC system. If the voltage drops are excessive, repair or replace the wiring system.

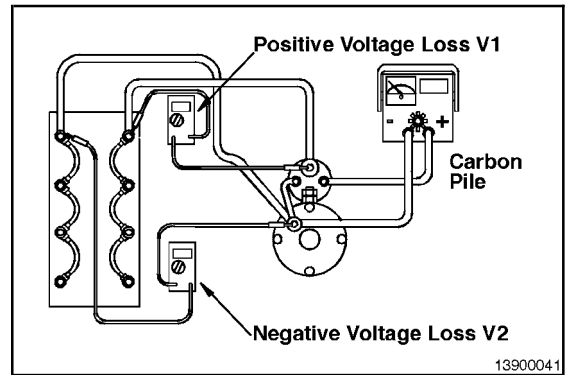

System Voltage	Maximum Voltage Drop
12 VDC	0.5 VDC
24 VDC	1.0 VDC

**⚠ WARNING ⚠**

Batteries can emit explosive gases. To avoid personal injury, always ventilate the compartment before servicing the batteries. To avoid arcing, remove the negative (-) battery cable first, and attach the negative (-) battery cable last.

Inspect the battery terminals for loose, broken, or corroded connections.

Repair or replace broken cables or terminals.

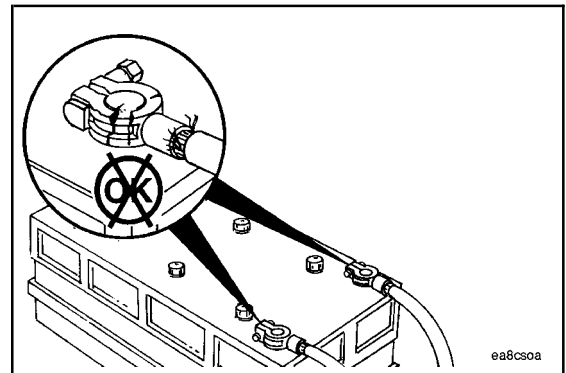

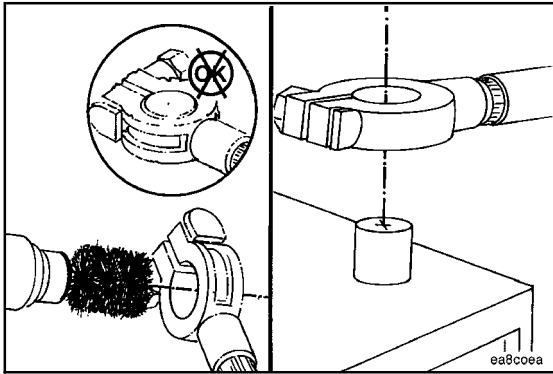

If the connections are corroded, remove the cables, and use a battery brush to clean the cable and battery terminals.



Install and tighten the battery cables.



Use dielectric grease to coat the battery terminals to prevent corrosion.

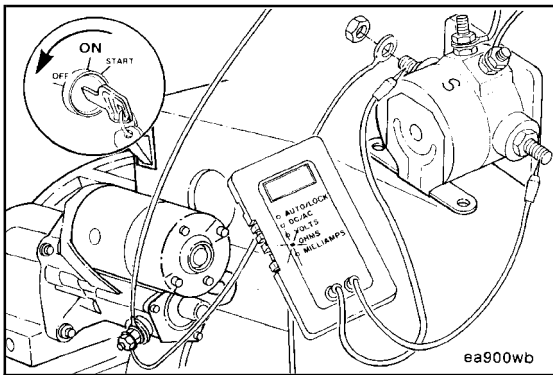

**Starter Magnetic Switch (013-017)**  
**Initial Check (013-017-001)**



**WARNING**

Be sure the starting motor switch is in the OFF position to prevent electrical shock and personal injury.



**Digital Multimeter, Part No. 3377161**

Remove the cable connecting the magnetic switch to the starting motor solenoid from the magnetic switch terminal.

Connect the leads of digital multimeter, Part No. 3377161, or equivalent, to the two large switch terminals.

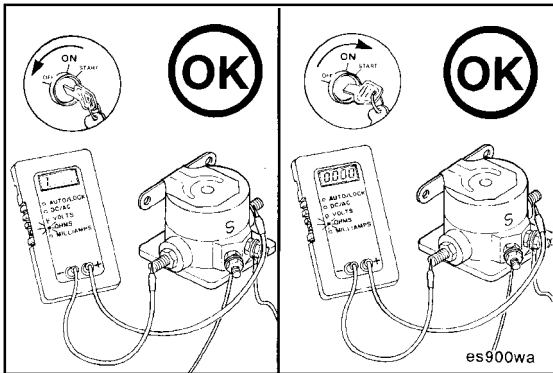

Set the multimeter to measure resistance (OHMS).

With the starting motor switch in the OFF position, the multimeter **must** indicate resistance at infinity.



Turn the starting motor switch to the START position.

The multimeter **must** indicate zero or very little resistance.

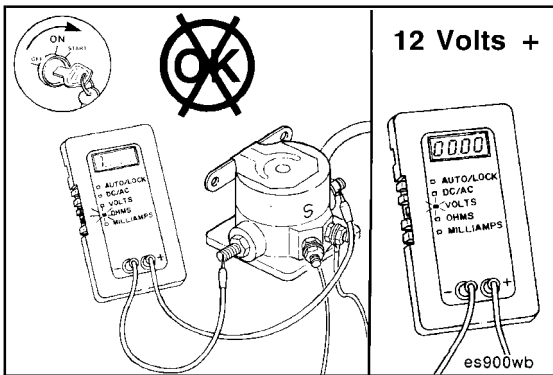

If the multimeter indicates resistance at infinity with the starting motor switch in the START position:

- Turn the starting motor switch to the OFF position.
- Set the multimeter scale to read DC voltage.

**B3.9 and B5.9 Series Engines**  
**Section 13 - Electrical Equipment - Group 13**

**Starter Magnetic Switch (013-017)**  
**Page 13-25**

- Connect one multimeter lead to the magnetic switch terminal marked "S" and the other lead to the ground.
- Turn the starting motor switch to the START position.
- If the multimeter indicates no voltage, the magnetic switch is **not** the cause of the complaint.
- If the multimeter indicates voltage, the magnetic switch is defective and **must** be replaced.

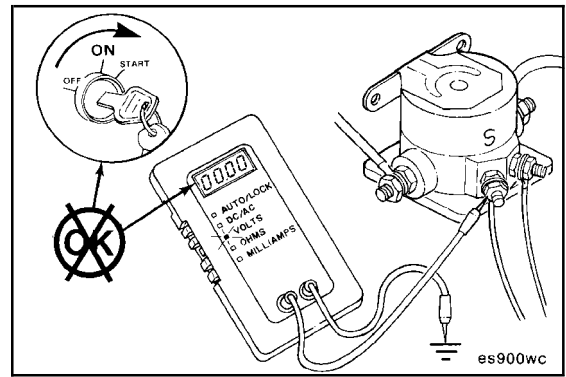

- Turn the starting motor switch to the OFF position.
- Remove the multimeter leads, and connect the magnetic switch to the starting motor solenoid wire.

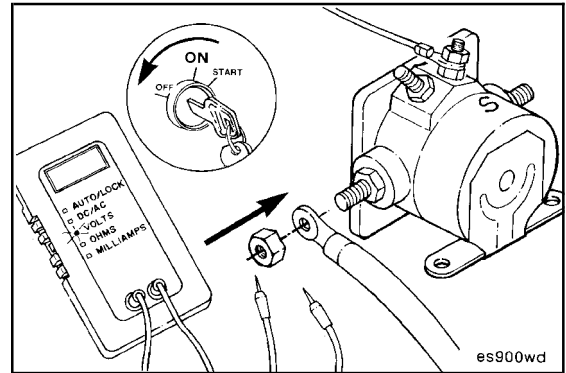

**Resistance Check (013-017-038)**



**Be sure the starter motor switch is in the OFF position to avoid personal injury from electrical shock.**

**Digital Multimeter, Part No. 3377161**

Remove the cable connecting the magnetic switch to the starter motor solenoid from the magnetic switch terminal.

Connect the leads of the digital multimeter, Part No. 3377161, or equivalent, to the two large switch terminals.

Set the digital multimeter, Part No. 3377161, to measure resistance (ohms).

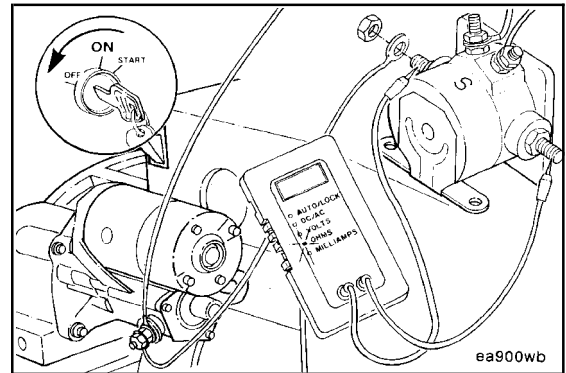

Connect the leads to the two large switch terminals.

With the starter motor switch in the OFF position, the multimeter **must** indicate resistance greater than 100k ohms.

Turn the starter motor switch to the START position.

The multimeter **must** indicate less than 10 ohms. If **not** within specifications, replace the starter magnetic switch according to the manufacturer's instructions.

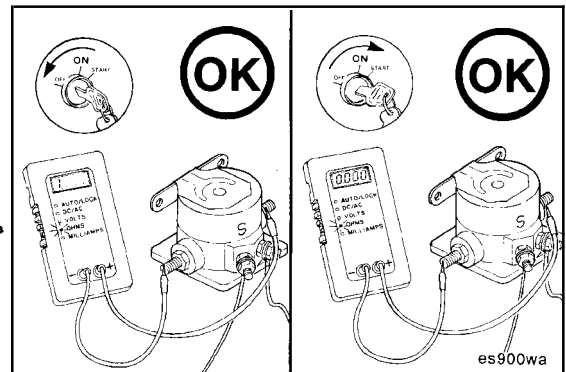

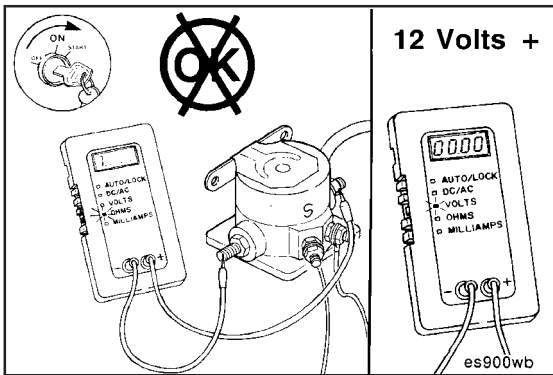

**Voltage Check (013-017-041)**

If the multimeter indicates resistance greater than 100k ohms with the starter motor switch in the START position:

- Turn the starter motor switch to the OFF position.
- Set the multimeter scale to read DC voltage.

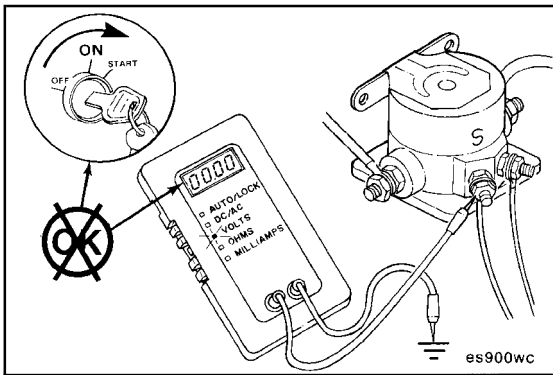

- Connect one multimeter lead to the magnetic switch terminal marked "S" and the other lead to the ground.
- Turn the starter motor switch to the START position.
- If the multimeter indicates no voltage, the magnetic switch is **not** the cause of the complaint. Refer to Procedure 013-018. If the starter magnetic switch is **not** within specification, replace the switch according to the manufacturer's instructions.

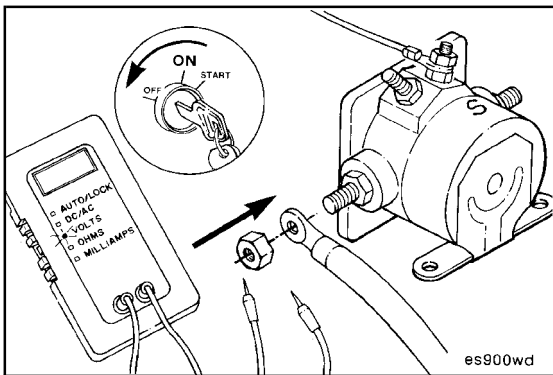

- Turn the starter motor switch to the OFF position.
- Remove the multimeter leads, and connect the magnetic switch to the starter motor solenoid wire.

### Starter Switch (013-018)

#### Initial Check (013-018-001)



**WARNING**

Be sure the starting motor switch is in the OFF position to avoid personal injury from electrical shock.

#### Digital Multimeter, Part No. 3377161

Remove the wire connecting the starting motor switch to the magnetic switch (marked "S" or START) from the starting motor switch terminal.

Connect the positive lead of digital multimeter, Part No. 3377161, or equivalent, to the starting motor switch terminal and the negative lead to a chassis or engine ground location.

**NOTE:** With the starting motor switch in the OFF position, there **must not** be voltage at the starting motor switch terminal. If the meter indicates voltage, the starting motor switch is malfunctioning and **must** be replaced.

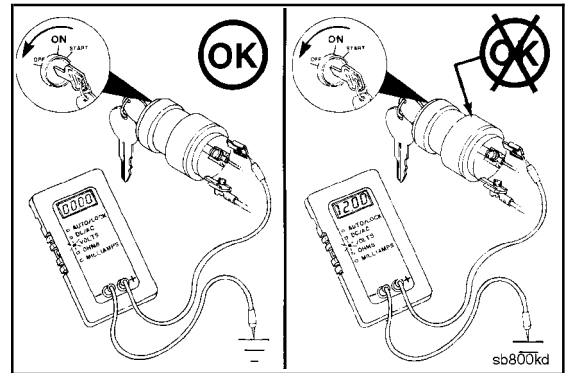
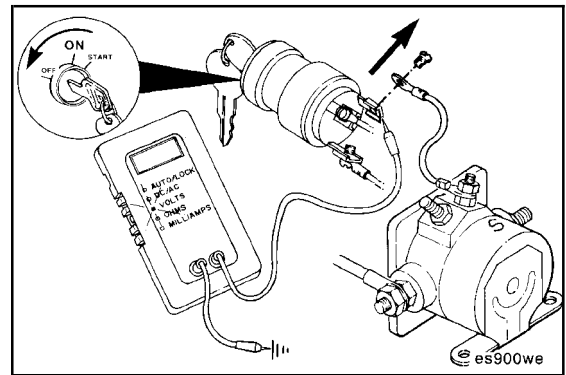

Turn the starting motor switch to the START position.  
The multimeter **must** indicate system voltage.

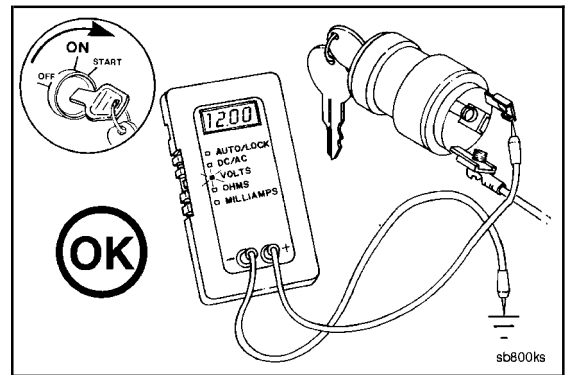

If there is no voltage:

- Turn the starting motor switch to the OFF position.
- Connect the multimeter positive lead to the starting motor switch terminal having a wire connecting the starting motor switch to the starting motor solenoid "B" terminal.

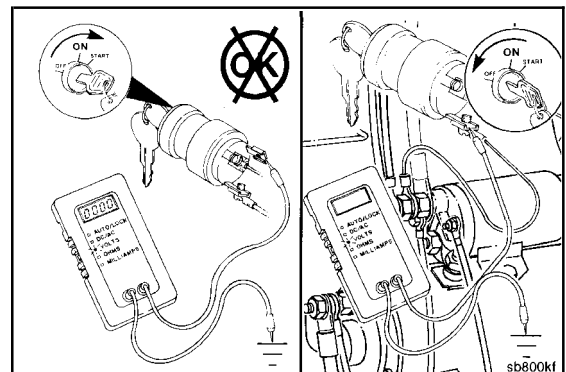

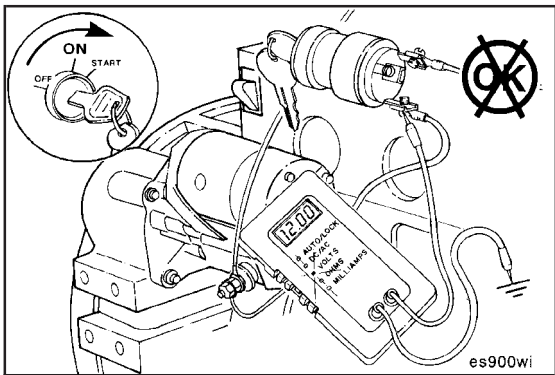

Turn the starter switch to the START position.

If the meter indicates system voltage at the starting motor switch input terminal, the starting motor switch is **not** the cause of the complaint.

Check the wiring from the starting switch to the starting motor solenoid "B" terminal, and from the starting motor solenoid to the battery for broken or damaged wires.

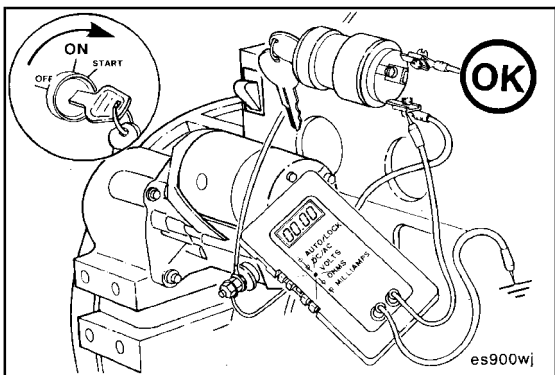

If the meter indicates no voltage, the switch is defective and **must** be replaced.

Check the wiring from the starting switch to the starting motor solenoid "B" terminal and from the starting motor solenoid to the battery for broken or damaged wires.

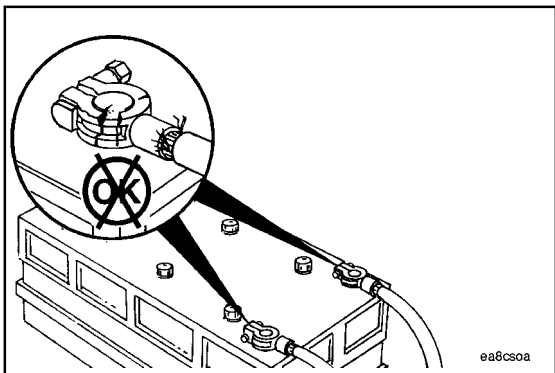

### Starter Solenoid (013-019)

#### Initial Check (013-019-001)

Before troubleshooting the starting motor, make sure the battery terminals are **not** loose or corroded.

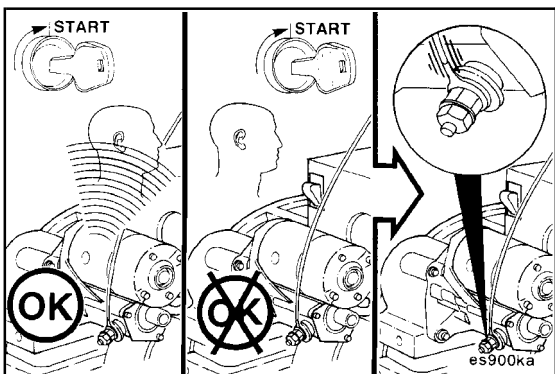

If the starting motor solenoid does **not** make a sound, check for loose wiring connections.



**Digital Multimeter, Part No. 3377161**

Use a digital multimeter, Part No. 3377161, or equivalent, to set the voltage scale.

Check for system voltage at the starting motor solenoid battery terminal.

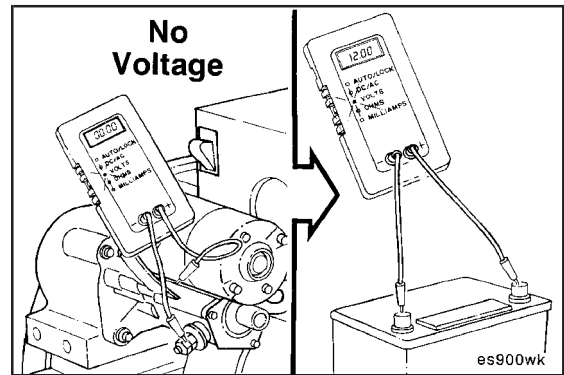

If the multimeter indicates system voltage at the starting motor battery terminal, check the voltage at the starting motor solenoid "S" terminal, while the starting switch is energized.

If the multimeter indicates system voltage at "S" terminal but the starter does **not** engage, the starting motor solenoid is malfunctioning and the starter **must** be replaced.

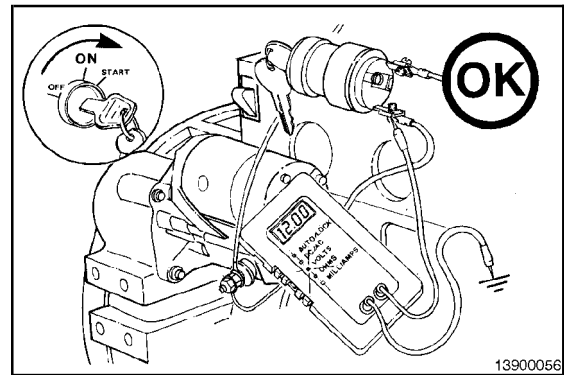

If the multimeter does **not** indicate system voltage at the "S" terminal, check:

- Fuses
- Voltage to the ignition switch and magnetic switch.
- Application safety shutoff systems.

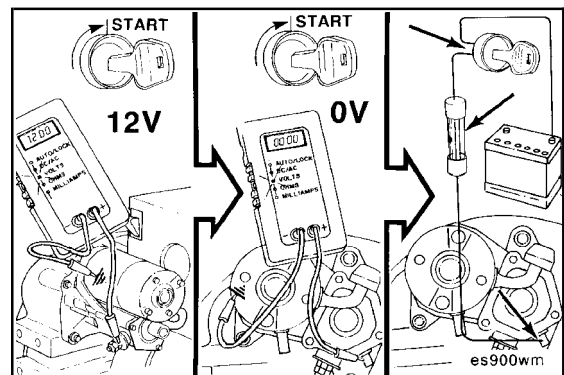

**Voltage Check (013-019-041)**

**Digital Multimeter, Part No. 3377161**

Set the digital multimeter, Part No. 3377161, to measure DC volts.

Connect the multimeter positive (+) lead to the starter solenoid positive cable terminal and the negative (-) lead to a chassis or engine ground location.

The multimeter **must** show voltage with the starter switch in the OFF position to be normal.

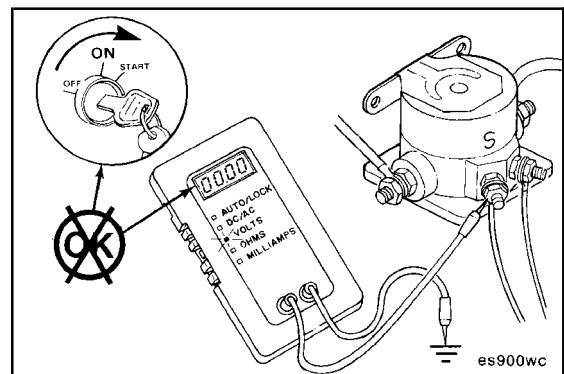

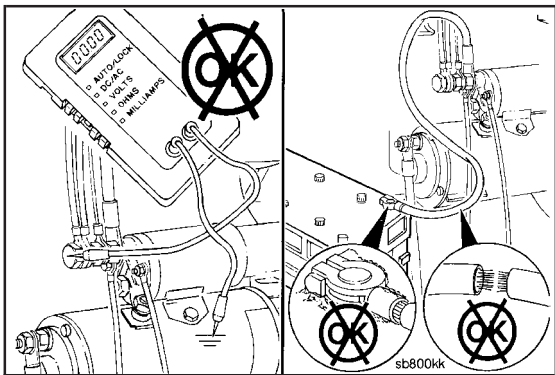

If the multimeter does **not** indicate voltage, check the cable connecting the starter solenoid and battery for breaks. Also, check for loose or corroded connections.

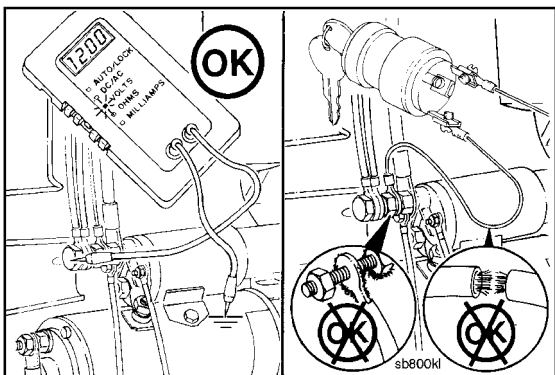

If the multimeter indicates voltage but the starter will **not** operate, check the wire connecting the starter solenoid to the starter switch for breaks, and also check for loose or corroded connections.

In addition be sure to check for:

- Fuses
- Application engine shutoff systems.

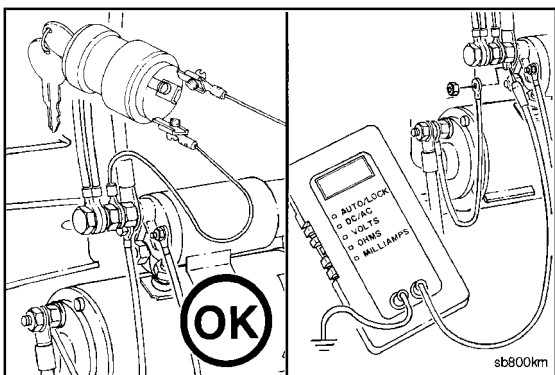

If the wire connecting the starter solenoid and starter switch is **not** loose or damaged and the starter will **not** operate:

- Remove the cable connecting the starter and starter solenoid from the solenoid terminal.
- Connect the multimeter positive (+) lead to the solenoid positive terminal and the negative (-) lead to the chassis or an engine ground location.

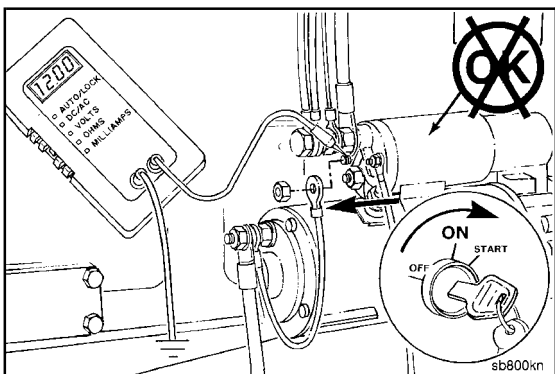

- Turn the starter switch to the START position.
- If the multimeter indicates voltage, the starter solenoid is malfunctioning and **must** be replaced.

**B3.9 and B5.9 Series Engines**  
**Section 13 - Electrical Equipment - Group 13**

- If the multimeter does **not** indicate voltage, check the wire connecting the starter solenoid to the magnetic switch for breaks, and for loose or corroded connections.

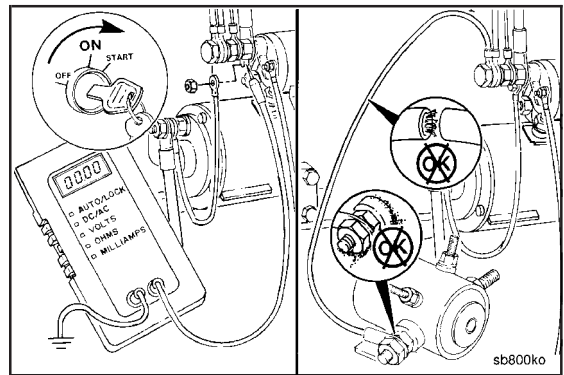

If the wire connecting the starter solenoid to the magnetic switch is **not** loose or damaged and the starter will **not** operate:

- Check the cable connecting the starter solenoid to the starter motor for breaks, and for loose or corroded connections.

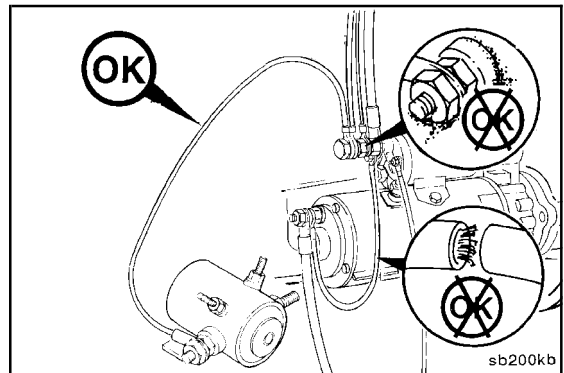

- Check the cable connecting the starter motor to the battery for breaks, and for loose or corroded connections.

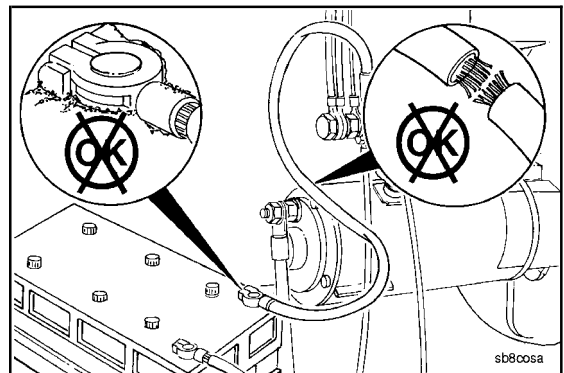

- If the cables are **not** loose or damaged, the starter motor is defective and **must** be replaced. Refer to Procedure 013-020.

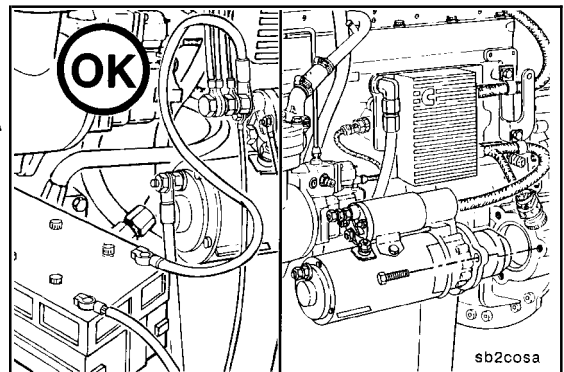

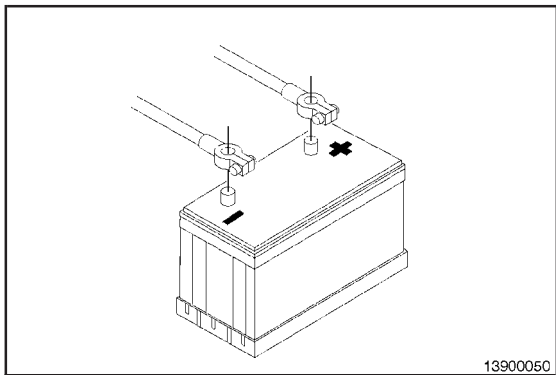

**Solenoid Control Circuit Voltage Drop on Delco® Starters**

Disconnect the battery.

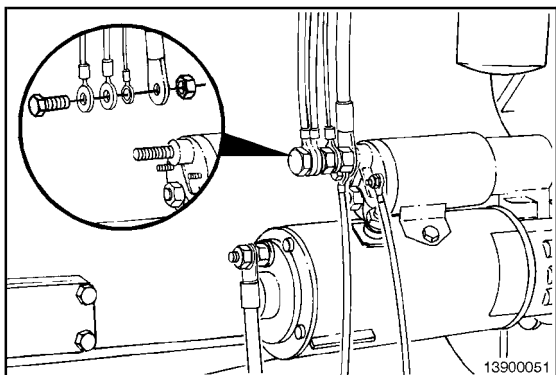

Remove all cables and connections from the battery terminal of the cranking motor.

Clamp all cables and connections together (a 1/2-inch bolt and nut works for clamping connections). Wrap a heavy cloth around the battery terminal of the cranking motor to be certain it does **not** touch any metal.

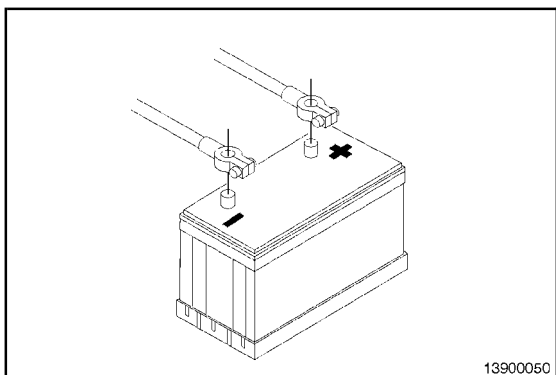

Connect the battery.

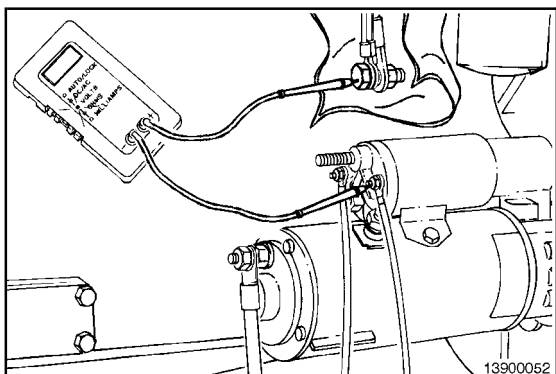

**Digital Multimeter, Part No. 3337161**

Connect a digital multimeter, Part No. 3337161, between battery positive (+) and the "S" terminal (the multimeter should show battery open circuit voltage, about 12.5 to 12.6 VDC).



**B3.9 and B5.9 Series Engines  
Section 13 - Electrical Equipment - Group 13**

Close the vehicle start switch and the very first reading is the voltage drop. If you wait, the voltage reading will drop rapidly as the solenoid heats up and raises the solenoid resistance. Be certain to record the very first reading.

**NOTE:** The motor will **not** crank if there is no voltage supplied to the motor.

Repeat the step with the multimeter connected between the battery negative (-) and motor negative (-). Add the voltages from the previous step and this step to get the control circuit voltage drop. Values are included in the table below.

With the hold-in and pull-in circuits both activated the maximum allowable voltage drop at 20°C [68°F] is:

VDC	Voltage Drop (maximum)
12	1.0 VDC
24	2.0 VDC
32	2.6 VDC

Motor	Solenoid Average Amperage Draw		
	VDC	PI & HI Amps	HI Amps
28MT	12	69	13
	24	120	13
37MT	12	74	19
	24	36	6
41/42MT	12	97	18
	24	57	13
50MT	12	86	15
	24	49	6
	32	38	6
	64	10	2

For 12 -DC systems, apply 10 VDC to the "S" terminal.  
 For 24-VDC systems, apply 20 VDC to the "S" terminal.  
 For some 32-VDC systems, apply 30 VDC to the "S" terminal.  
 For some 32-VDC and all 64-VDC systems, apply 30 VDC to the "B +" terminal.

Disconnect the battery.

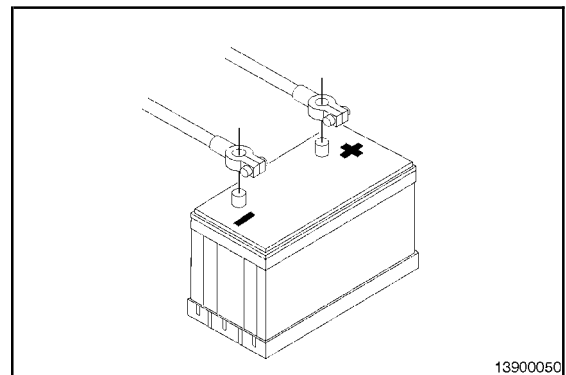
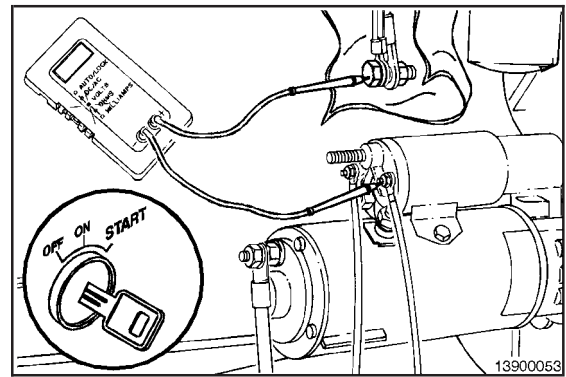
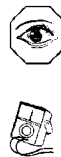

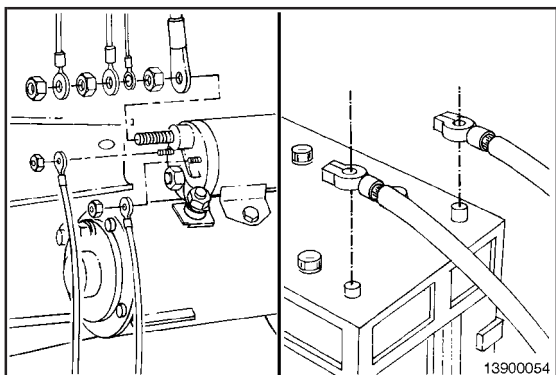

Replace all connections to the battery terminal of the motor and then reconnect the battery.

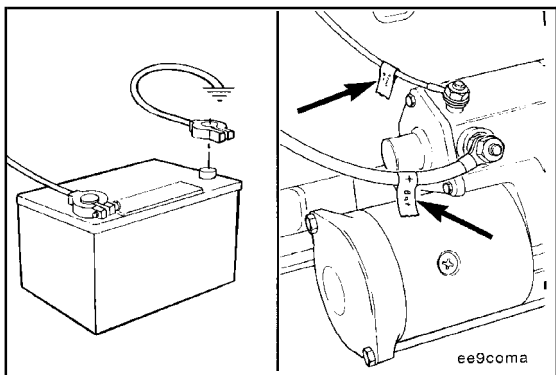

**Starting Motor (013-020)  
Preparatory (013-020-000)**

- Disconnect the ground cable from the battery terminal.
- Identify each electrical wire with a tag indicating location.

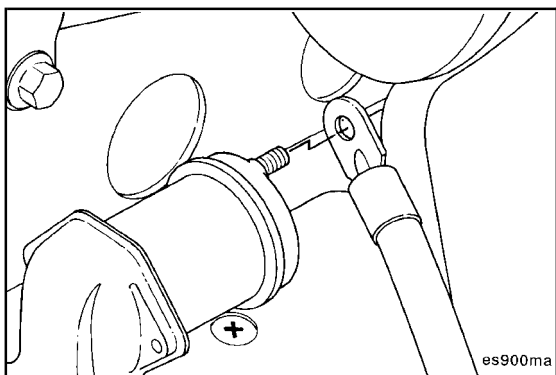

**Remove (013-020-002)**

17 mm



- Remove the battery cable from the solenoid.
- Remove all other wires connected to the starter.

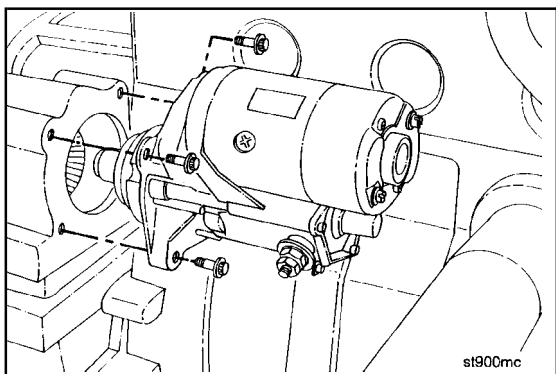

10 mm

Remove the starter motor.



**Test (013-020-012)**

Check for system voltage at the "M" terminal of the starting motor while the starter switch is energized.

- System Voltage: Starting motor is malfunctioning or **not** adequately grounded and **must** be repaired or replaced.
- No Voltage: Starting motor solenoid is malfunctioning and **must** be replaced.

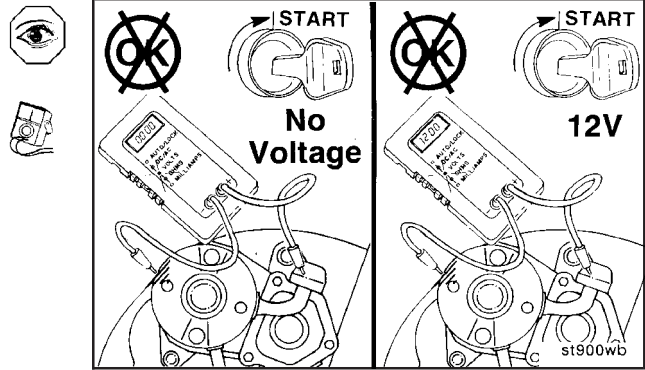

If the starting motor solenoid makes a sound, turn the switch off, and attempt to bar the crankshaft in both directions.

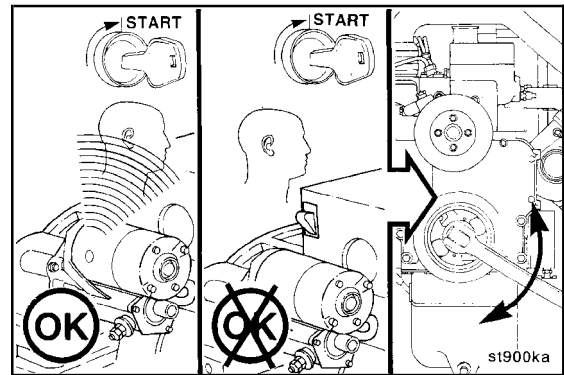

Bar the crankshaft as follows:

1. Direction of engine rotation
2. Direction opposite engine rotation
3. Direction of engine rotation.

If the crankshaft will bar over, attempt to start the engine. If the starting motor cranks the engine, check the starting motor pinion gear and flywheel ring gear for damage.

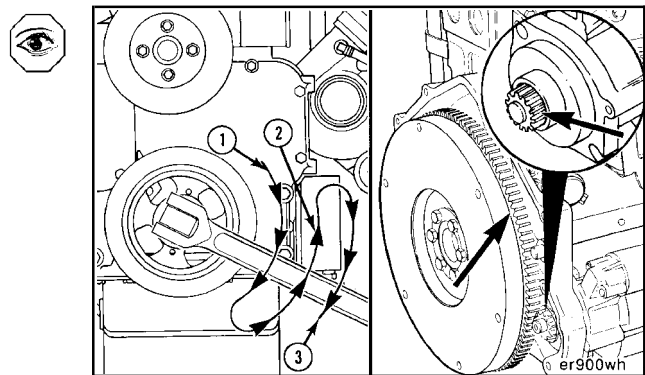

**Engine Cranking Speed Too Slow**

Make sure the wiring connections are clean, tight and **not** damaged.

Check the battery voltage. Refer to Procedure 013-007.

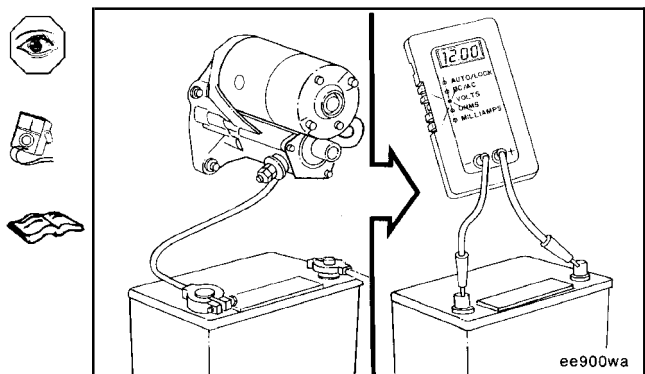

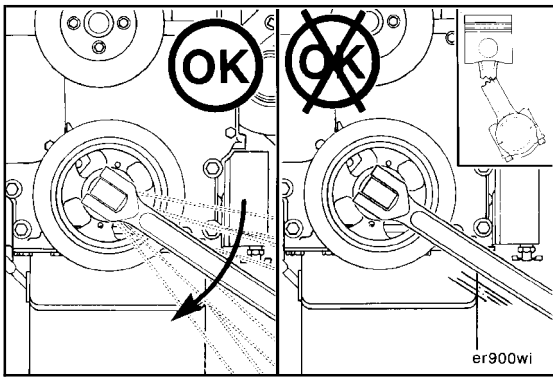

If the crankshaft was **not** rotated to check the starting motor, bar the crankshaft in the direction of engine rotation to make sure the engine is free and does **not** have an internal malfunction.

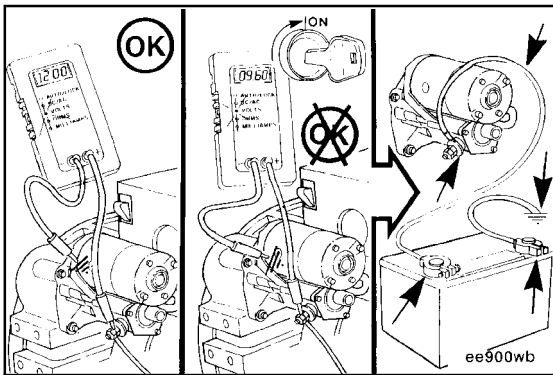

If the engine is free, check the voltage at the starting motor during cranking. If the voltage drops more than 2.4 VDC on a 12-VDC system, check that all connections are tight. The limit for 24-VDC systems is 4.8 VDC.

If the cables are correct and the voltage drop exceeds the limit, replace the starting motor.

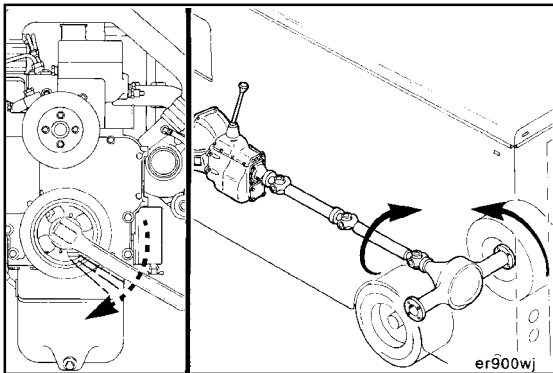

If the crankshaft requires more than normal effort to bar, check for excessive load from the driven units and accessories.

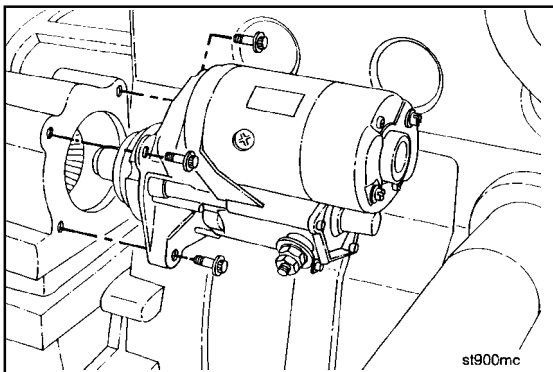

**Install (013-020-026)**



**WARNING**



Batteries emit explosive gases. To avoid personal injury, always ventilate the compartment before servicing the batteries. To avoid arcing, remove the negative (-) battery cable first and attach the negative (-) battery cable last.



10 mm

Install the starter motor in the reverse order of removal.

Connect all cables connecting ground (-) last.

**Torque Value:** 43 N•m [32 ft-lb]



**Rotation Check (013-020-052)**

**Barring Tool, Part No. 3824591**

If the starter motor solenoid makes a sound, turn the switch to the OFF position, and attempt to bar the crankshaft in both directions.

Bar the engine using the barring tool, Part No. 3824591.

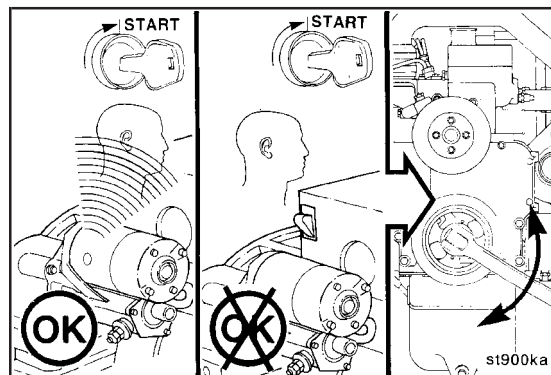

Bar the crankshaft as follows:

1. Direction of engine rotation
2. Direction opposite engine rotation
3. Direction of engine rotation.

If the crankshaft will over, attempt to start the engine. If the starter motor cranks the engine, check the starter motor pinion gear and flywheel ring gear for damage.

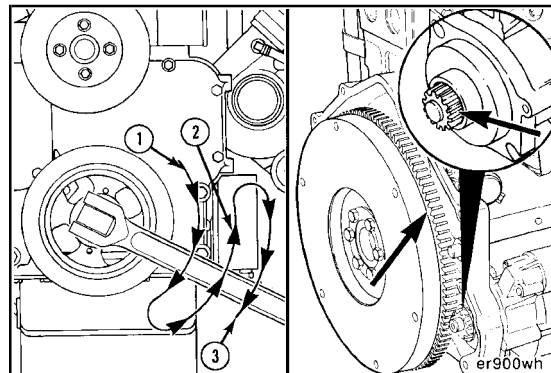



## Section 14 - Engine Testing - Group 14

### Section Contents

	<b>Page</b>
<b>Crankcase Blowby, Measure</b> .....	14-27
Measure .....	14-27
<b>Engine Run-in (Chassis Dynamometer)</b> .....	14-9
Test .....	14-9
<b>Engine Run-in (Engine Dynamometer)</b> .....	14-18
Test .....	14-18
<b>Engine Run-in (Without Dynamometer)</b> .....	14-10
Test .....	14-10
Off-Highway Applications .....	14-11
On-Highway Applications .....	14-10
<b>Engine Testing - General Information</b> .....	14-3
<b>Engine Testing (Chassis Dynamometer)</b> .....	14-4
Setup .....	14-4
Test .....	14-6
<b>Engine Testing (Engine Dynamometer)</b> .....	14-12
Setup .....	14-12
<b>Engine Testing (In Chassis)</b> .....	14-22
Initial Check .....	14-22
Test .....	14-24
<b>Service Tools</b> .....	14-1
Engine Testing .....	14-1
<b>Specifications</b> .....	14-3
Engine Testing .....	14-3

**THIS PAGE LEFT INTENTIONALLY BLANK**

## Service Tools Engine Testing

The following special tools are recommended to perform procedures in this section. The use of these tools is shown in the appropriate procedure. These tools can be purchased from your local Cummins Authorized Repair Location.

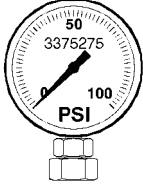
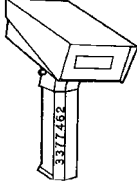
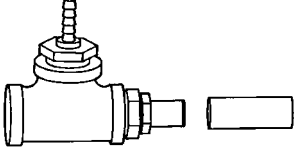
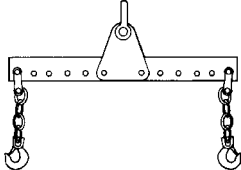
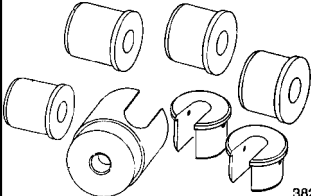
Tool No.	Tool Description	Tool Illustration
3375049	<b>Oil Filter Wrench</b> Use to remove or tighten spin-on lubricating oil or fuel filters.	 <p style="text-align: right; font-size: small;">If8togb</p>
3375275	<b>Pressure Gauge (0 to 160 psi)</b> Used to measure lubricating oil pressure.	 <p style="text-align: right; font-size: small;">3375275</p>
3377462	<b>Digital Optical Tachometer</b> Used to measure engine speed (rpm).	 <p style="text-align: right; font-size: small;">3377462.</p>
3822476	<b>Blowby Checking Tool</b> Use to check engine crankcase blowby.	 <p style="text-align: right; font-size: small;">eg8l0ge</p>
3822512	<b>Engine Lifting Fixture</b> Used to remove and install the engine.	 <p style="text-align: right; font-size: small;">3822512</p>
3824842	<b>Compuchek® Fitting</b> Used for connection to diagnostics machine.	 <p style="text-align: right; font-size: small;">3824842</p>

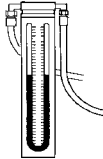
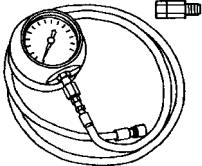
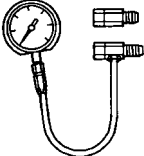
Tool No.	Tool Description	Tool Illustration
ST-1111-3	<p><b>Manometer</b></p> <p>Used with the blowby check tool to measure engine crankcase pressure.</p>	 <p style="text-align: right; font-size: small;">eg100ja</p>
ST-1273	<p><b>Pressure Gauge</b></p> <p>Used to measure engine intake manifold pressure, exhaust restriction, lift pump output pressure, and pressure drop across the fuel filter.</p>	 <p style="text-align: right; font-size: small;">eg8togi</p>
ST-434	<p><b>Vacuum Gauge</b></p> <p>Used to measure lift pump inlet restriction. Hose adapter, Part No. ST-434-2, and vacuum gauge, Part No. ST-434-12, are used to perform the test.</p>	 <p style="text-align: right; font-size: small;">eg8togg</p>

## Engine Testing - General Information

The engine test is a combination of an engine run-in and a performance check. The engine run-in procedure provides an operating period that allows the engine parts to achieve a final finish and fit. The performance check provides an opportunity to perform final adjustments needed to optimize the engine's performance.

An engine test can be performed using either an engine dynamometer or a chassis dynamometer. If a dynamometer is **not** available, an engine test **must** be performed in a manner that simulates a dynamometer test.

Check the dynamometer before beginning the test. The dynamometer **must** have the capability to test the performance of the engine when the engine is operating at the maximum rpm and horsepower range (full power).

The engine crankcase pressure, often referred to as engine blowby, is an important factor that indicates when the piston rings have achieved the correct finish and fit. Rapid changes of blowby or values that exceed specifications more than 50 percent indicate that something is wrong. The engine test **must** be discontinued until the cause has been determined and corrected.

## Specifications

### Engine Testing

Maintain the following limits (see note) during a chassis dynamometer test:

#### Intake Restriction (maximum)

##### Clean Filter:

Light-Duty .....	254 mm H <sub>2</sub> O [10 in H <sub>2</sub> O]
Medium-Duty .....	305 mm H <sub>2</sub> O [12 in H <sub>2</sub> O]
Heavy-Duty .....	381 mm H <sub>2</sub> O [15 in H <sub>2</sub> O]

##### Dirty Filter:

Light-Duty .....	635 mm [25 in]
Medium-Duty .....	635 mm [25 in]
Heavy-Duty .....	635 mm [25 in]

Exhaust Back Pressure (maximum) Nonautomotive ..... 76 mm Hg [3.0 in Hg]

Exhaust Back Pressure (maximum) Automotive with Catalyst .. 152 mm Hg [6.0 in Hg] to 127 mm Hg [5.0 in Hg]

Back Pressure (maximum) Automotive without Catalyst ..... 114 mm Hg [4.5 in Hg] to 102 mm Hg [4.0 in Hg]

#### Oil Pressure:

Low Idle (minimum allowable) .....	69 kPa [10 psi]
Rated Speed (minimum allowable) .....	207 kPa [30 psi]

Fuel Inlet Restriction (maximum) ..... 100 mm Hg [4 in Hg]

Fuel Return Restriction (maximum) ..... 518 mm Hg [20.4 in Hg]

**NOTE:** Due to variations in ratings of different engine models, refer to the specific engine data sheet for the particular engine model being tested.

## Engine Testing (Chassis Dynamometer) (014-002)

### Setup (014-002-011)

The performance of an engine installed in on-highway vehicles can be tested on a chassis dynamometer.

**NOTE:** Due to driveline efficiency and engine-driven accessories, the engine horsepower when measured at the rear wheels will be reduced by approximately:

- 20 percent for single-axle vehicles
- 25 percent for tandem-axle vehicles

**NOTE:** These percentages are used for engine run-in **only** and are **not** to be used as absolute figures.

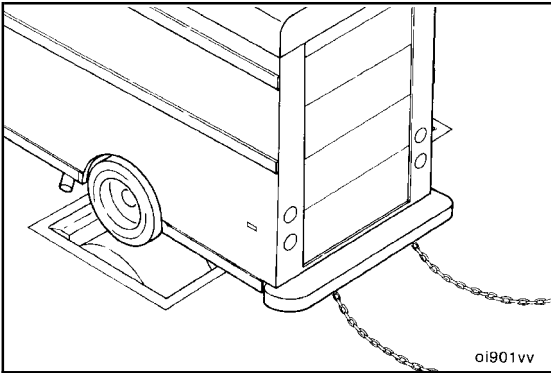
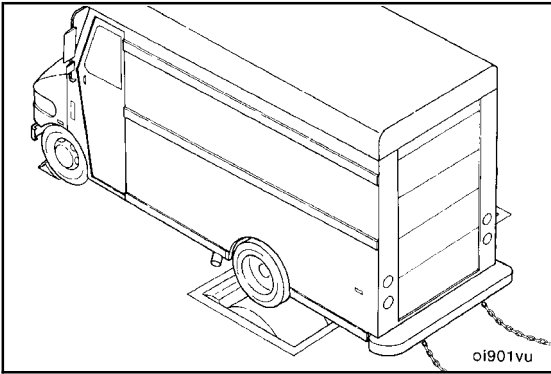

### ⚠ WARNING ⚠

Follow all the vehicle manufacturer's safety precautions before installing or operating a vehicle on a chassis dynamometer. Failure to do so can result in personal injury.

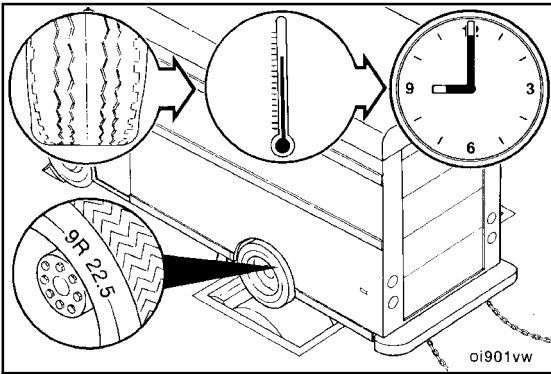

### ⚠ CAUTION ⚠

Low-profile radial tires are more sensitive to heat than bias-ply tires. Excessive operating time at full load can damage tires due to overheating. Check the tire manufacturer's recommendations for the maximum allowable chassis dynamometer operating time.

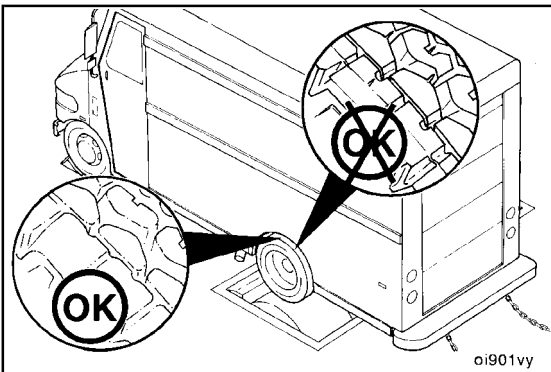

Follow the general safety precautions listed below while operating the chassis dynamometer:

- Use tires that have more than 160 kilometers [100 miles] on them. Do **not** use new tires.
- Do **not** use recapped tires or tires of different sizes or designs.



- Make sure the tires are inflated to the manufacturer's specifications.
- Remove all rocks or other material from the tread of all tires that will be rotating on the dynamometer rollers.

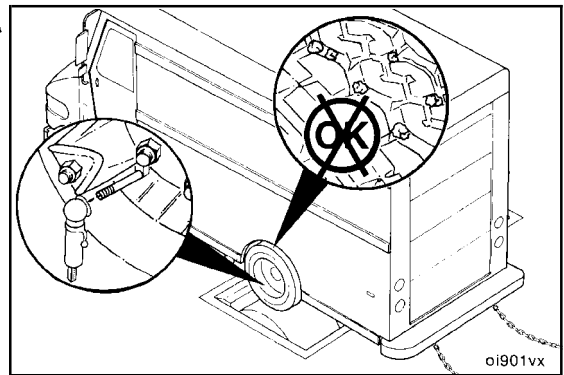

- Make sure there is correct overhead clearance for exhaust stacks, air deflectors, or other attachments above the cab.

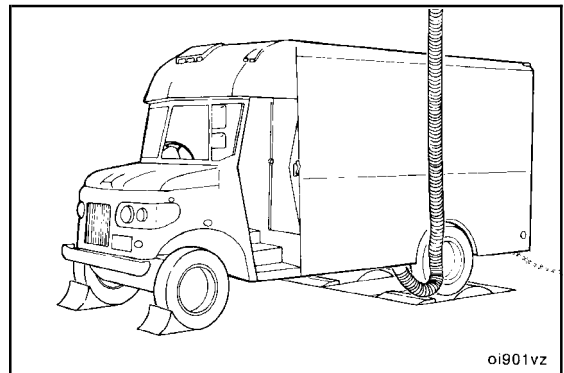

**⚠ CAUTION ⚠**

To prevent damage to the chassis dynamometer, there must be some slack in the tension of the tie-down chains.

Carefully position the vehicle on the rollers.

Attach the tie-down chains to the rear of the vehicle, and put wheel chocks in front of the front wheels.

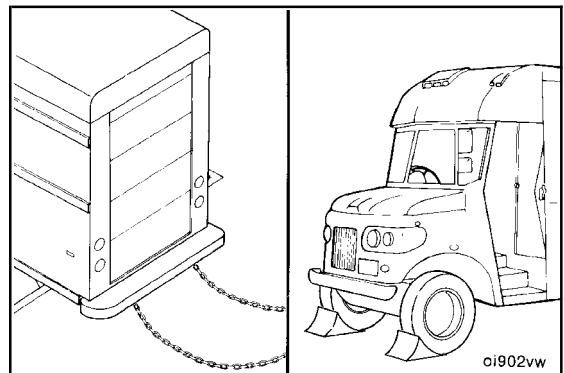

Adjust the vehicle and dynamometer room exhaust system to make sure all exhaust gases are removed from the room.

Refer to the chassis dynamometer and vehicle manufacturer's recommendations and specifications for testing procedures.

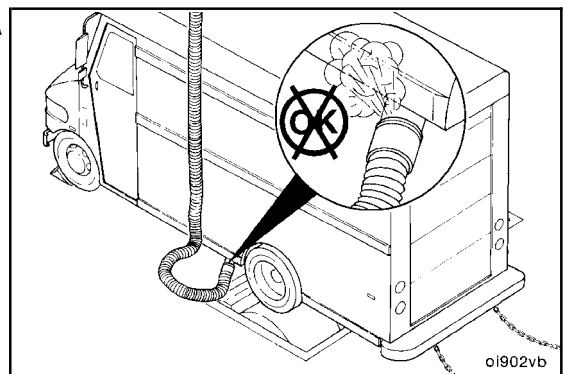

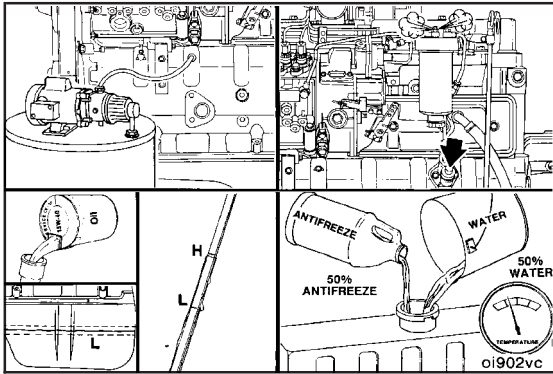

**Test (014-002-012)**

The following procedure assumes that the lubricating oil and fuel systems were correctly primed, the dipstick calibrated, and the engine filled to the correct levels with lubricating oil and coolant during installation of the engine into the chassis. If these systems were **not** serviced during installation of the engine, refer to Procedure 014-006 for instructions on priming the lubricating oil and the fuel system requirements, and calibrating the dipstick. Refer to the Operation and Maintenance Manual, B Series, Bulletin No. 3810205, for instructions on filling the lubricating oil and the cooling systems.

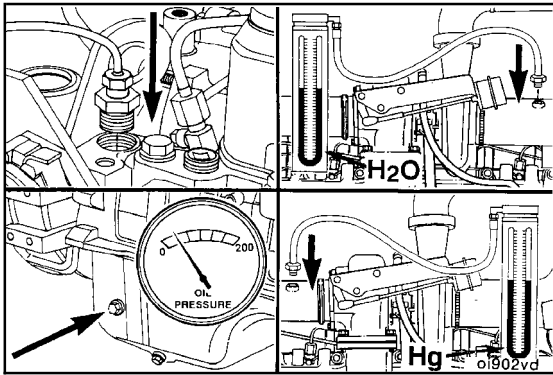

The number of instruments and gauges required to perform a chassis dynamometer test will vary according to the type and the capability of the test equipment used.

Refer to the service tools listed at the beginning of this section.

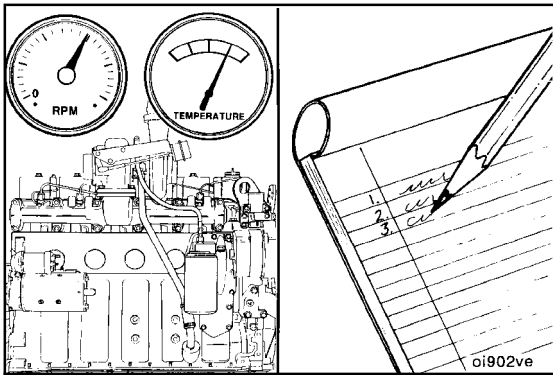

To monitor an engine's performance correctly, record the following parameters:

- Exhaust back pressure
- Lubricating oil pressure (vehicle instrument panel)
- Coolant temperature (vehicle instrument panel)
- Coolant pressure\*
- Intake manifold pressure\*
- Inlet air restriction\*
- Blowby\*
- Engine speed (rpm) (vehicle instrument panel)
- Wheel horsepower (WHP) (dynamometer controls)
- Fuel supply pressure.

\*See the following for the Service Tools required and the installation locations on the engine.

Measure the coolant pressure at a coolant tap on the exhaust side of the cylinder head.

**Minimum Gauge Capacity:** 415 kPa [60 psi]

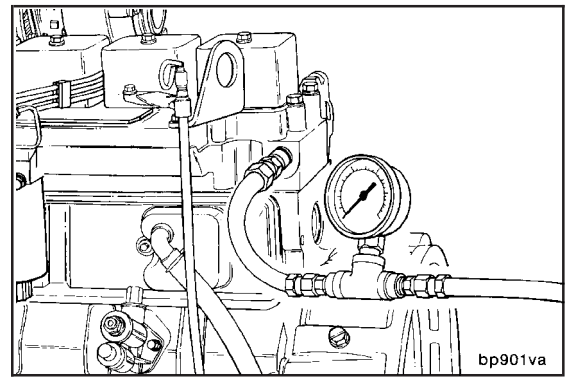

bp901va

**Pressure Gauge, Part No. ST-1273**

Install a pressure gauge, Part No. ST-1273, in the location shown.

Measure the intake manifold pressure (turbocharger boost).

**Minimum Gauge Capacity:**

1905 mm Hg [75 in Hg]

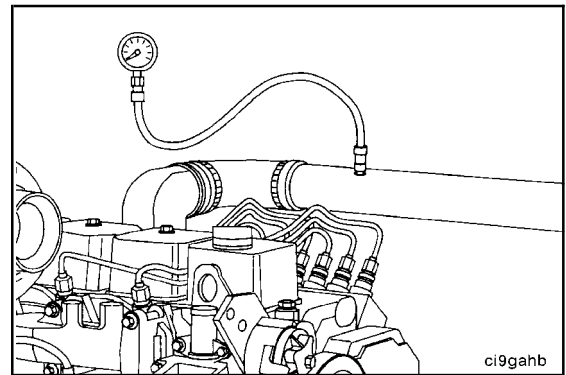

ci9gahb

**Water Manometer, Part No. ST-1111-3**

**Vacuum Gauge, Part No. ST-434**

Connect a water manometer, Part No. ST-1111-3, to the turbocharger air inlet pipe to test air restriction.

**NOTE:** The manometer connection **must** be installed at a 90 degree angle to the airflow in a straight section of pipe, one pipe diameter before the turbocharger, and be in between the turbocharger and the air filter.

**NOTE:** A vacuum gauge, Part No. ST-434, can be used in place of the water manometer.

**Minimum Gauge Capacity:**

760 mm H<sub>2</sub>O [30 in H<sub>2</sub>O]

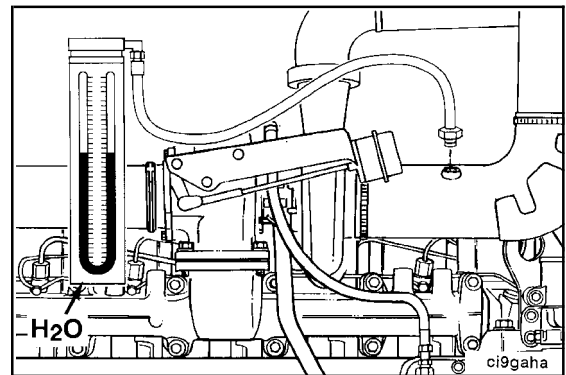

H<sub>2</sub>O

ci9gaha

**Blowby Checking Tool, Part No. 3822476**

Measure the blowby by installing blowby checking tool, Part No. 3822476, in the crankcase breather vent. Connect the blowby tool to a water manometer.

**NOTE:** Excessive blowby indicates a turbocharger malfunction or an internal engine component malfunction, allowing combustion gases to enter the crankcase.

**Minimum Gauge Capacity:**

1270 mm H<sub>2</sub>O [50 in H<sub>2</sub>O]

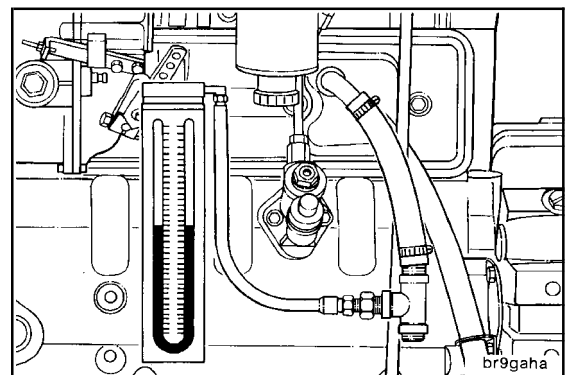

br9gaha

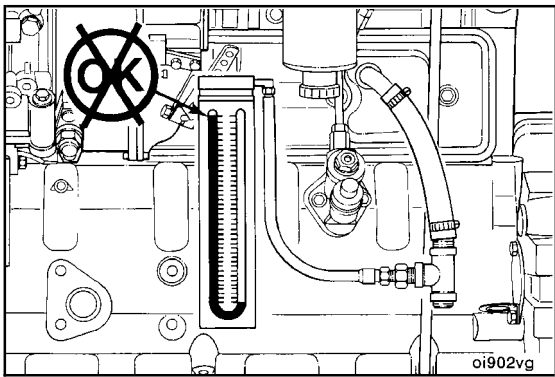

**NOTE:** If a sudden increase in blowby occurs or if blowby exceeds the maximum allowable limit during any run-in step, return to the previous step and continue the run-in. If blowby does **not** reach an acceptable level, discontinue the run-in and determine the cause.

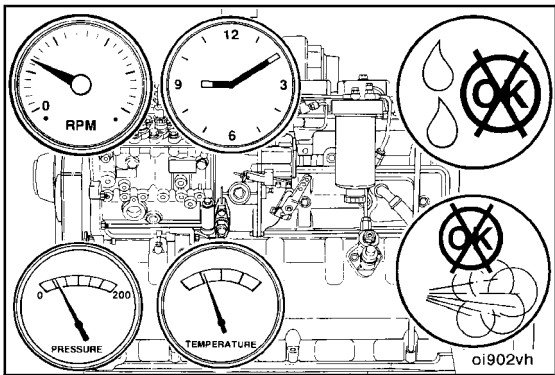

**NOTE:** Avoid long idle periods. Operate the engine at low idle **only** long enough (3 to 5 minutes) to check for correct lubricating oil pressure and any fuel, lubricating oil, water, or air leaks.

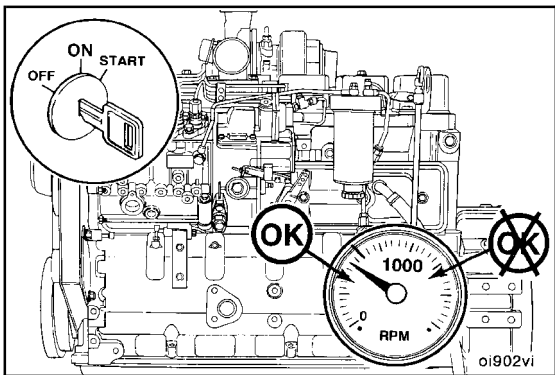

**CAUTION**

Do not allow the engine speed to exceed 1000 rpm before run-in. The internal components can be damaged.

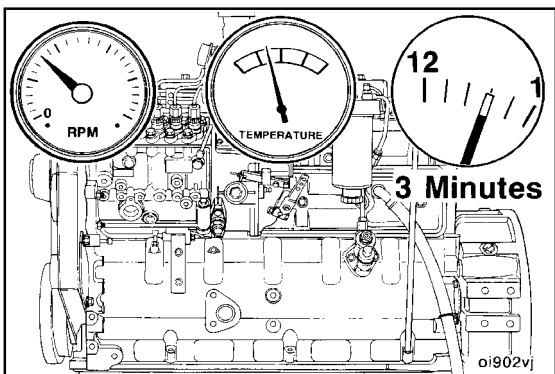

**CAUTION**

Do not operate the engine at idle speed longer than specified during engine run-in. Excessive carbon formation can cause damage to the engine.

**CAUTION**

Do not shut off the engine immediately after the last step of the run-in is completed. Allow the engine to cool by operating at low idle for a minimum of 3 minutes to avoid internal component damage.

### Engine Run-in (Chassis Dynamometer) (014-003)

#### Test (014-003-012)

**NOTE:** Refer to Procedure 014-002 before operating the engine to avoid internal component damage.

**NOTE:** Refer to Procedure 014-005 for general operating procedures and safety precautions.

**NOTE:** Operate the vehicle in a gear that produces a road speed of 90 to 95 km/h [56 to 59 mph].

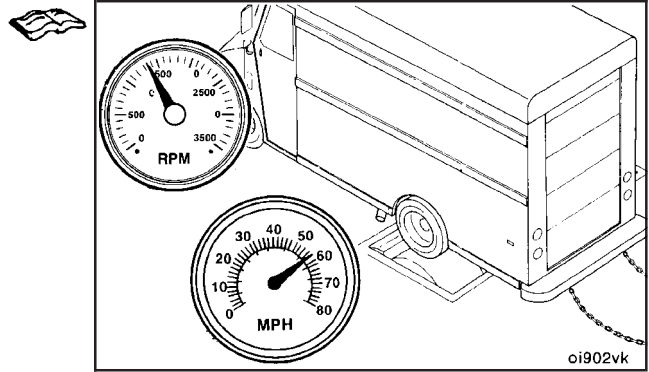

Operate the engine at 1200 rpm and 25 percent of torque peak load until the water temperature reaches 70°C [158°F].

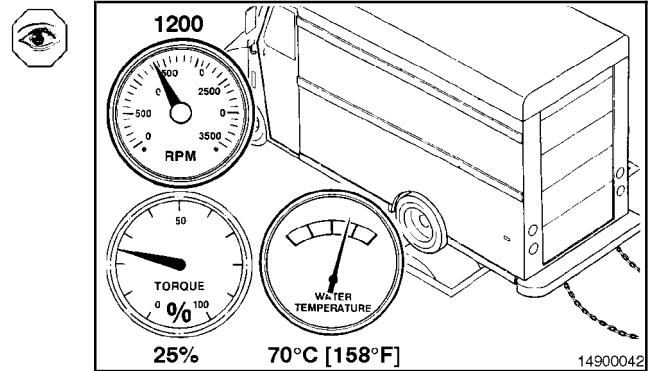

Operate the engine at 1200 rpm and 40 percent of torque peak load for 2 minutes. Check the gauges, and record the readings.

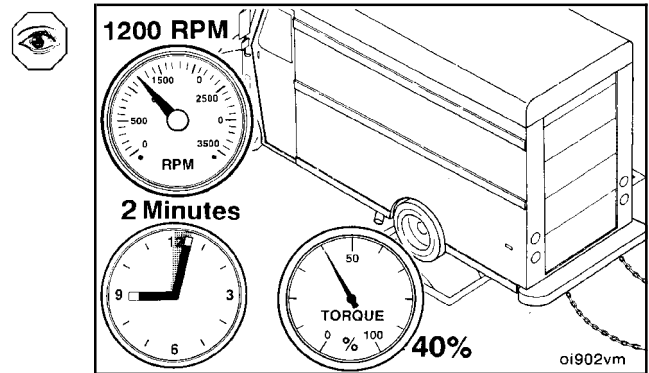

Operate the engine at 1600 rpm and 65 percent of torque peak load for 5 minutes. Check the gauges, and record the readings.

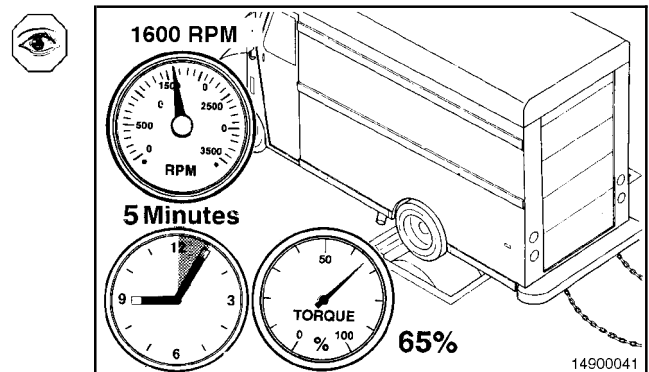

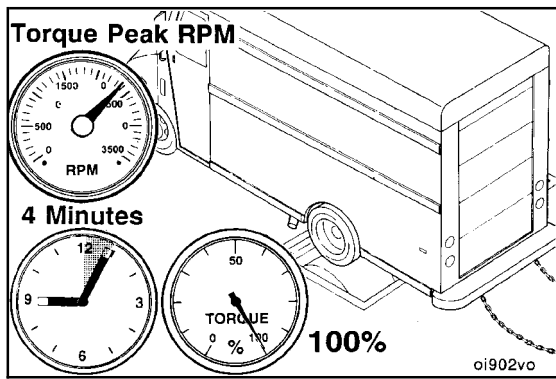

Operate the engine at torque peak rpm and full load for 4 minutes. Check the gauges and record the readings.



**NOTE:** Refer to the engine data sheet for the torque peak rpm of the engine model being tested.

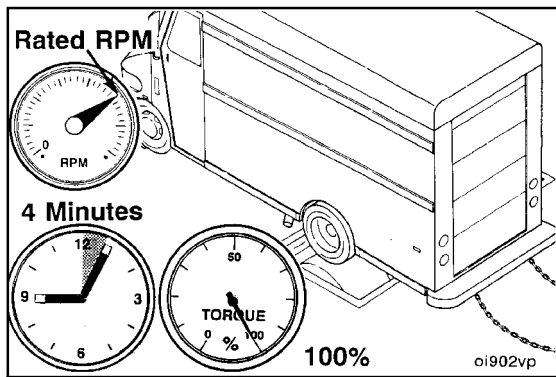

Operate the engine at rated speed (rpm) and full load for 4 minutes. Check the gauges, and record the readings. Compare the readings to those published on the appropriate engine data sheet.



**CAUTION**

**Do not shut off the engine immediately after the run-in is completed. Allow the engine to cool by operating it at low idle for a minimum of 3 minutes to avoid internal component damage.**

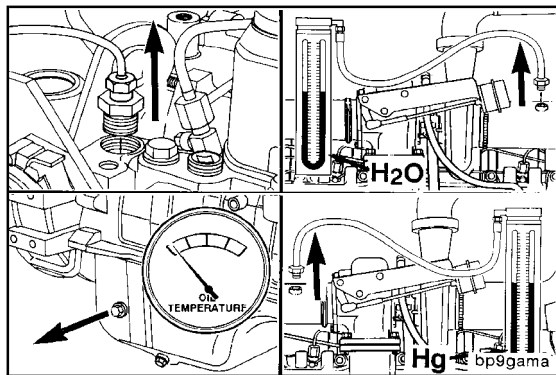

Make sure all instrumentation is removed before removing the vehicle from the dynamometer.

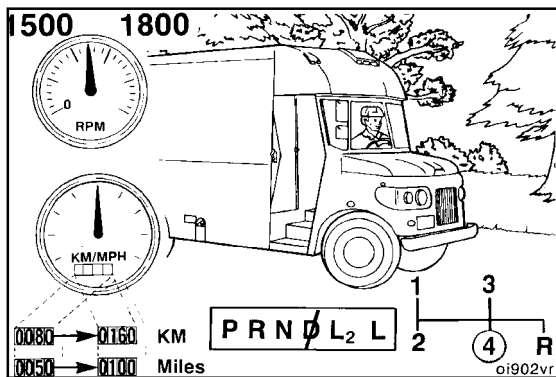

**Engine Run-in (Without Dynamometer) (014-004)**

**Test (014-004-012)**

**On-Highway Applications**

**NOTE:** Refer to General Engine Test Procedures (Chassis Dynamometer) (Procedure 014-005) before operating the engine to avoid internal component damage.

Operate the engine at 1500 to 1800 rpm in high gear for the first 80 to 160 km [50 to 100 mi] after rebuild.

**NOTE:** Do **not** idle the engine for more than 5 minutes at any one time during the first 160 km [100 mi] of operation.

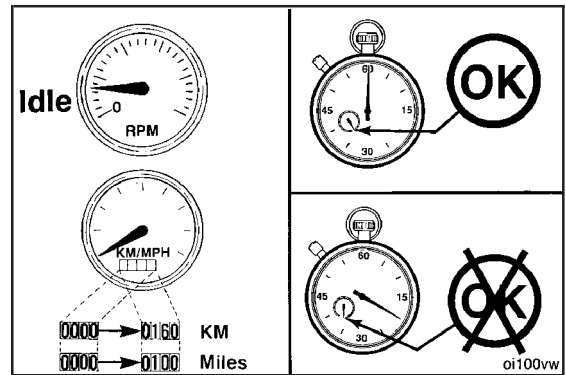

**Off-Highway Applications**

**NOTE:** Refer to General Engine Test Procedures (Chassis Dynamometer) (Procedure 014-005) before operating the engine to avoid internal component damage.

Operate the engine as follows during the first 3 hours after rebuild:

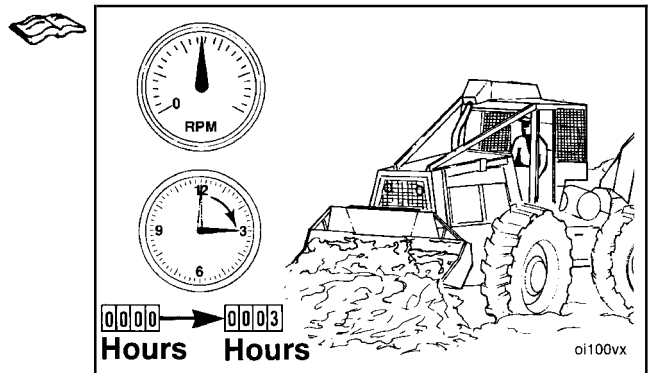

1. Do **not** idle the engine for more than 5 minutes at any one time.
2. Operate the engine at 75-percent throttle while loaded.

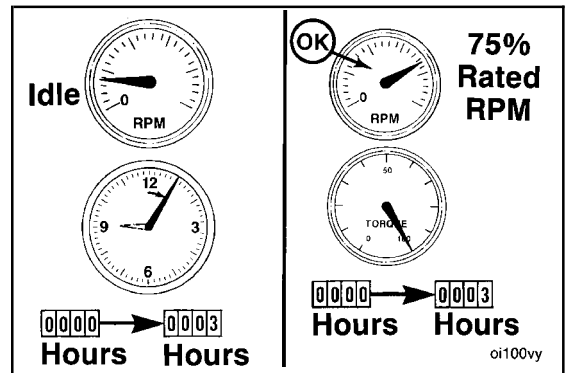

3. Do **not** operate the engine at rated speed (rpm) and full load for more than 5 minutes at any one time.

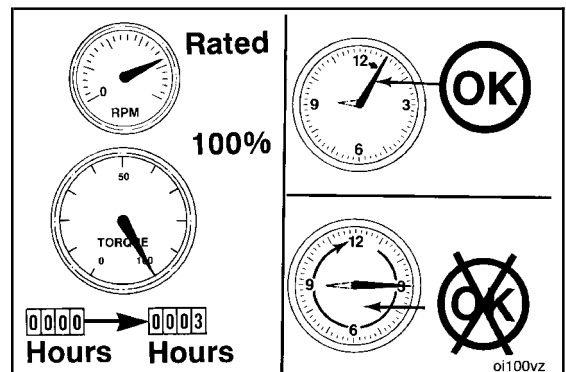

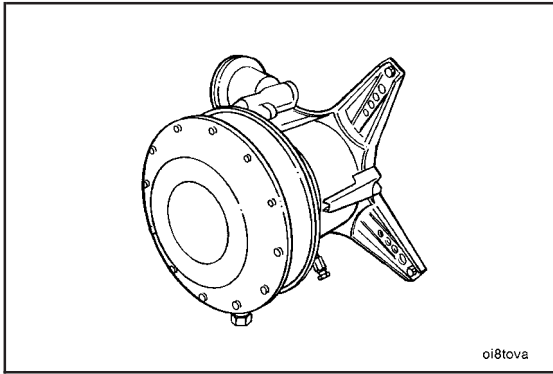

oi8tova



## Engine Testing (Engine Dynamometer) (014-005)

### Setup (014-005-011)



Engine Lifting Fixture, Part No. 3822512

Use engine lifting fixture, Part No. 3822512, to remove the engine from the chassis. Refer to Procedure 000-001.



Install the engine to the test stand.



Align and connect the dynamometer. Refer to the manufacturer's instructions for aligning and testing the engine.

**NOTE:** Make sure the dynamometer capacity is sufficient to permit testing at 100 percent of the engine-rated horsepower. If the capacity is **not** enough, the testing procedure **must** be modified to the restrictions of the dynamometer.

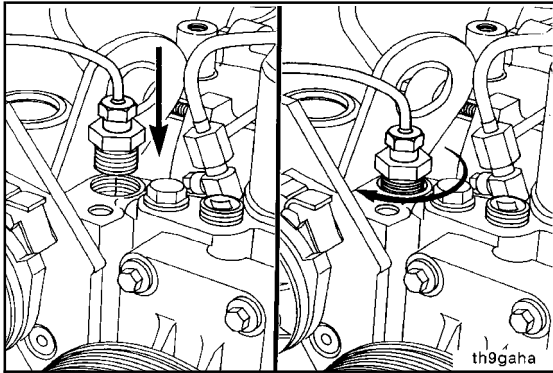

th9gaha



### Coolant Plumbing

Install the coolant temperature sensor.

#### Minimum Gauge Capacity:

107 °C [225 °F]

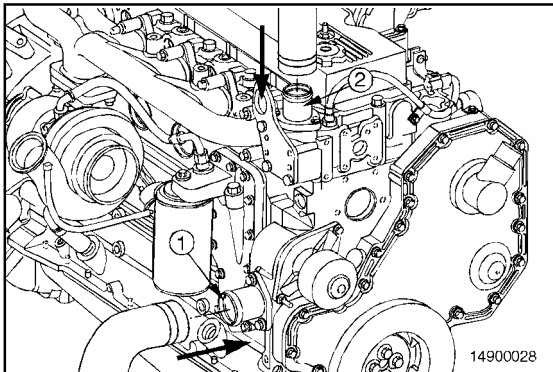

14900028



Connect the coolant supply to the water inlet connection (1).

Connect the coolant return to the water outlet connection (2).

Install the drain plugs, close all the water drain cocks, and make sure all the clamps and fittings are tight.

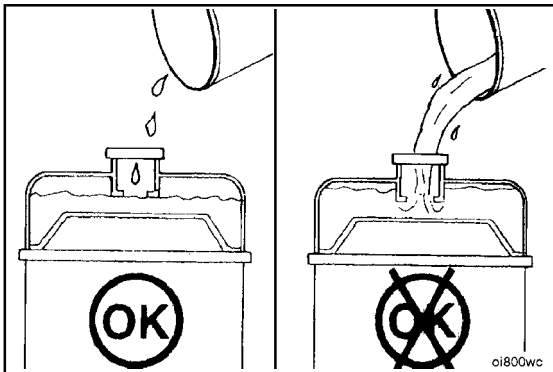

oi800wc

Fill the cooling system with coolant to the bottom of the fill neck in the radiator fill (or expansion) tank.



Inspect the engine for coolant leaks at connections, fittings, plates, and plugs. Repair as necessary.

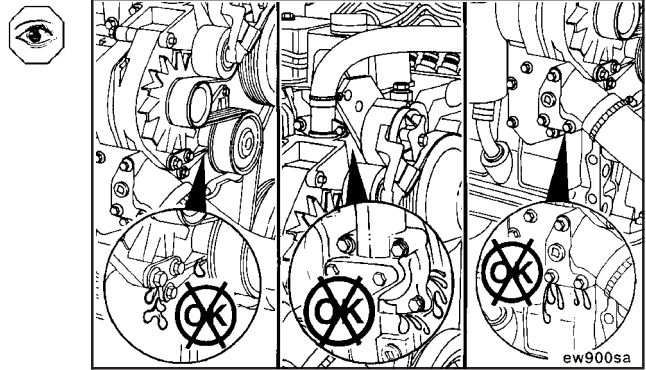

**Water Manometer, Part No. ST-1111-3**

**Air Inlet Restriction**

Connect a water manometer, Part No. ST-1111-3, to the turbocharger air inlet pipe to test air restriction.

**NOTE:** The manometer connection **must** be installed at a 90-degree angle to the air flow in a straight section of pipe, one pipe diameter before the turbocharger.

**NOTE:** A vacuum gauge, Part No. ST-434, can be used in place of the water manometer.

**Minimum Gauge Capacity:**

760 mm H<sub>2</sub>O [30 in H<sub>2</sub>O]

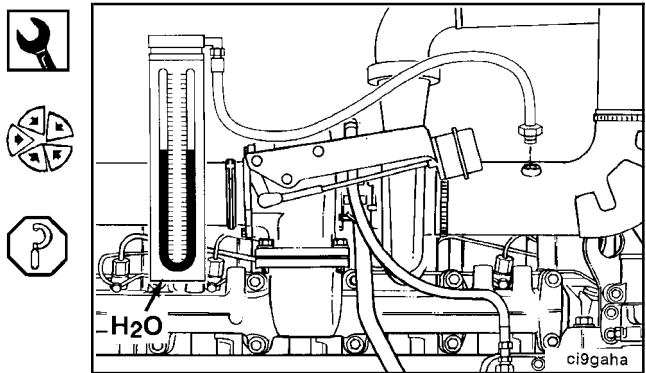

**Pressure Gauge, Part No. ST-1273**

**Exhaust Restriction**

Connect a mercury manometer to a straight section of the exhaust piping near the turbocharger outlet to check exhaust restriction.

**NOTE:** A pressure gauge, Part No. ST-1273, can be used in place of the mercury manometer.

**NOTE:** For automotive applications a tapped hole is provided on the inlet side of the catalyst for checking exhaust restrictions.

**Minimum Gauge Capacity:**

254 mm Hg [10 in Hg]

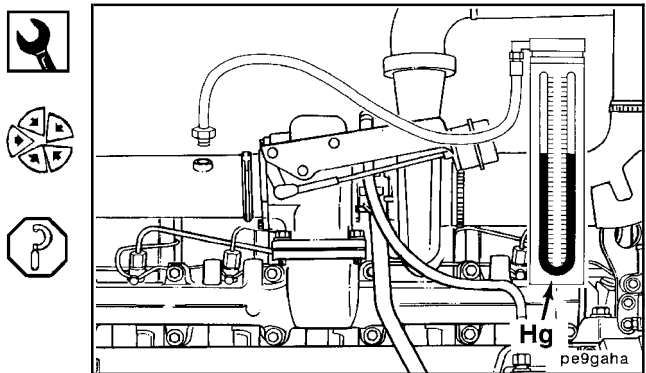

Attach the lubricating oil temperature sensor in the location shown.

**Minimum Gauge Capacity:**

150 °C [302 °F]

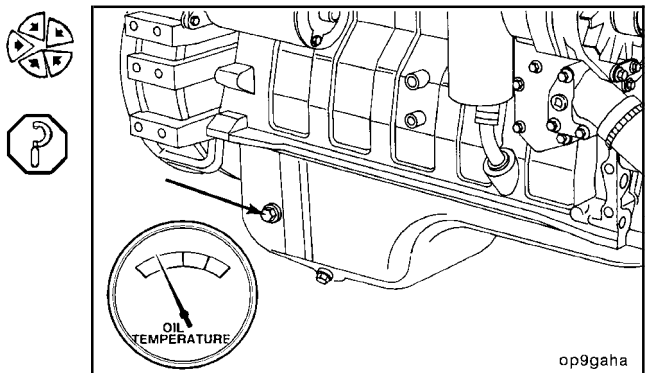

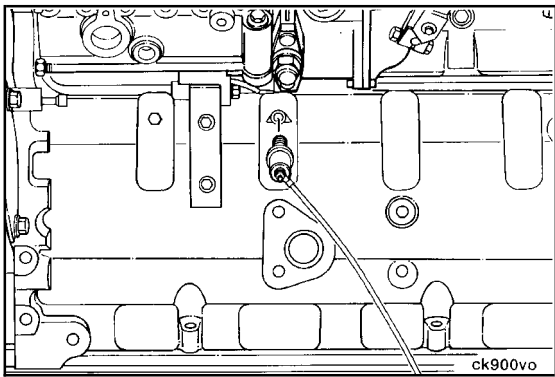

Attach the lubricating oil pressure sensor to the main oil rifle drilling in the cylinder block.

**Minimum Gauge Capacity:**



1034 kPa [150 psi]

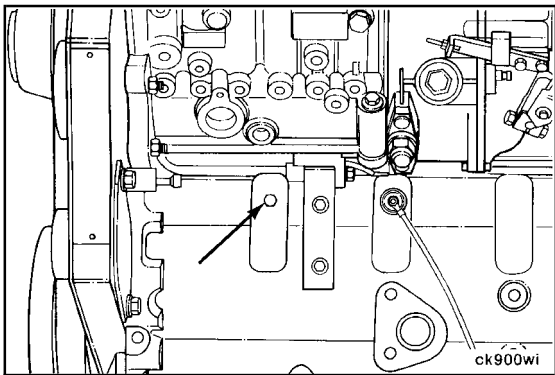

**CAUTION**

The lubricating oil system must be primed before operating the engine after it has been rebuilt to avoid internal damage.

To prime the system using external pressure, connect the supply to a tapped hole in the main lubricating oil rifle.

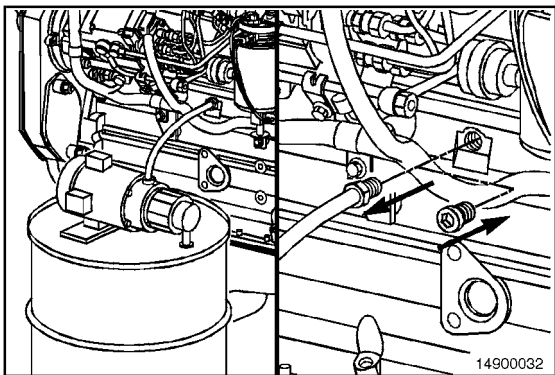

Use a pump capable of supplying 210 kPa [30 psi] of continuous pressure. Connect the pump to the port on the main lubricating oil rifle as shown.



Use clean lubricating engine oil to prime the system until the oil pressure registers on the gauge.

Remove the lubricating oil supply tube, and install the plug.

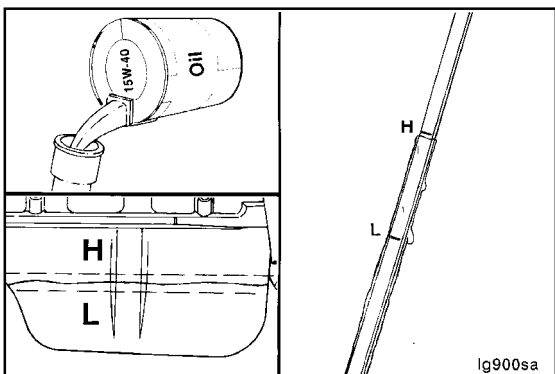

Make sure the lubricating oil has had time to drain to the lubricating oil pan, and fill the engine to the high mark as measured on the dipstick.

If an external pressure pump is **not** available, prime the lubricating system according to the following procedure.  
 Fill the engine with lubricating oil to the high level mark on the dipstick.

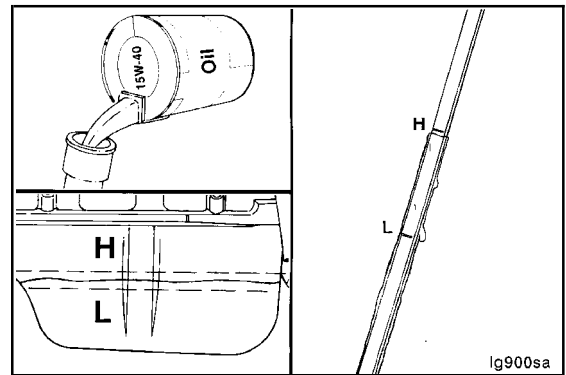

Disconnect the turbocharger lubricating oil supply tube.  
 Pour 50 to 60 cc [2.0 to 3.0 fl oz] of clean lubricating engine oil into the turbocharger lubricating oil supply hole.  
 Connect the lubricating oil supply tube to the turbocharger.

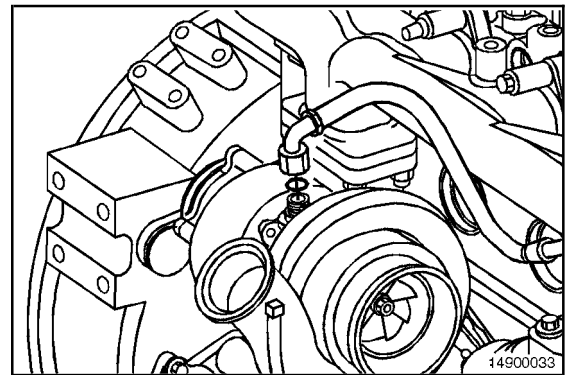

**⚠ CAUTION ⚠**

**Mechanical overtightening can distort the threads or damage the filter element seal.**

Fill the lubricating oil filters with clean lubricating engine oil.  
 Screw the filters onto the filter head fitting until the gasket contacts the filter head surface.  
 Tighten the filter as specified by the manufacturer.

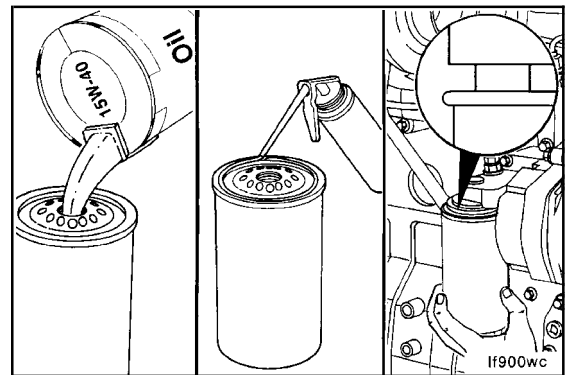

**⚠ CAUTION ⚠**

**Do not crank the starter motor for periods longer than 30 seconds. Excessive heat will damage the starter motor.**

Crank the engine until the lubricating oil pressure gauge indicates system pressure.  
**NOTE:** Allow 2 minutes between the 30-second cranking periods so the starter motor can cool.  
**NOTE:** If pressure is **not** indicated, find and correct the problem before continuing.

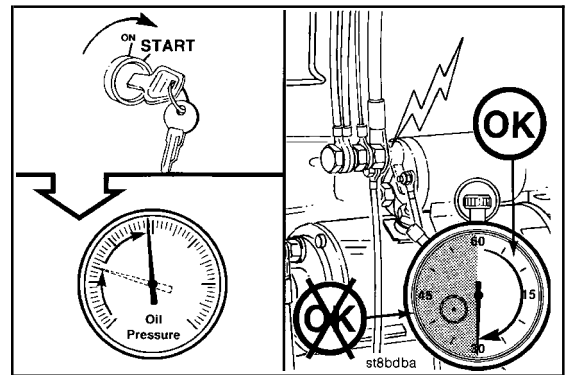

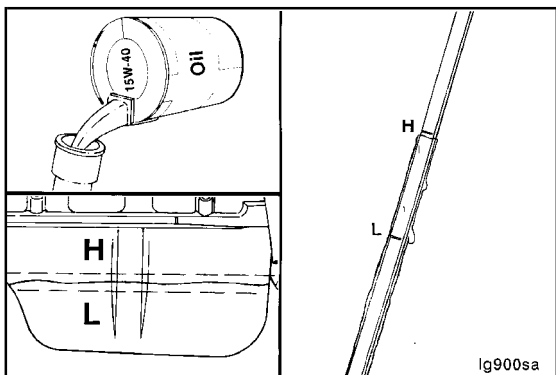

Allow the lubricating oil to drain into the lubricating oil pan, and measure the lubricating oil level with the dipstick.

Add lubricating oil, as necessary, to bring the level to the high level mark.

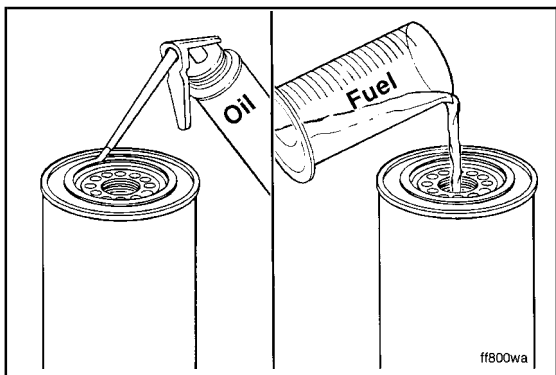

Lubricate the gasket on the fuel filter with clean lubricating engine oil.

Fill the fuel filter with clean fuel.

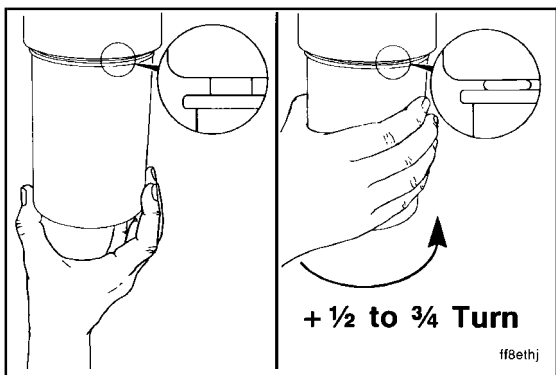

Screw the fuel filter onto the filter head until the gasket contacts the filter head surface.

Tighten the filter as specified by the manufacturer.

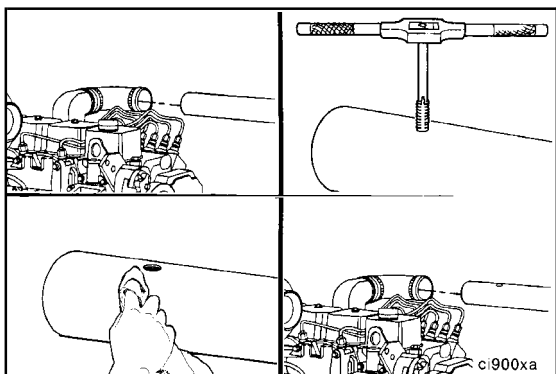

**CAUTION**

Do not attempt to install pipe thread fittings in plastic or rubber intake piping. Failure to do so will result in damage to threads.



If the air crossover tube does not have a pipe plug and tapped hole, perform the following procedure:



- Remove the air crossover tube from the engine.
- Drill and tap a 1/8-inch pipe thread hole in the crossover tube in the location shown.
- Clean all metal shavings from the air crossover tube.
- Install the crossover tube.

**Pressure Gauge, Part No. ST-1273**

To determine the amount of turbocharger boost, remove the pipe plug in the air crossover tube.

Install the intake manifold pressure sensor or pressure gauge, Part No. ST-1273.

**Minimum Gauge Capacity:**

1905 mm Hg [75 in Hg]

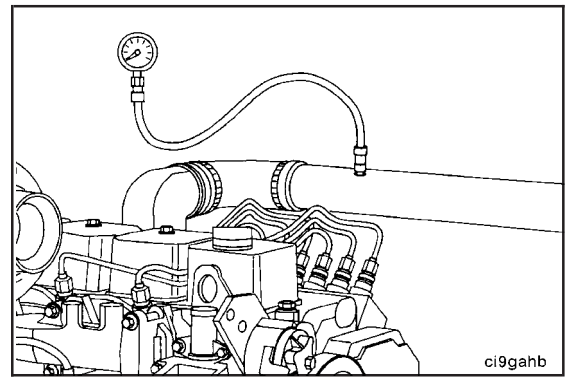

ci9gahb

**Blowby Checking Tool, Part No. 3822476**

**Water Manometer, Part No. ST-1111-3**

For accurate engine crankcase blowby measurement, insert a blowby checking tool in the crankcase breather vent.

Connect a water manometer to the blowby tool. A pressure gauge can be used in place of the manometer.

**Minimum Gauge Capacity:**

1270 mm H<sub>2</sub>O [50 in H<sub>2</sub>O]

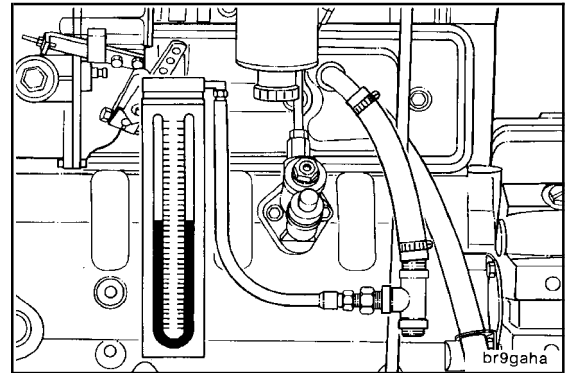

br9gaha

**Vacuum Gauge, Part No. ST-434**

To measure fuel filter restriction, connect vacuum gauge, Part No. ST-434, to the injection pump inlet line.

**Minimum Gauge Capacity:**

760 mm Hg [30 in Hg]

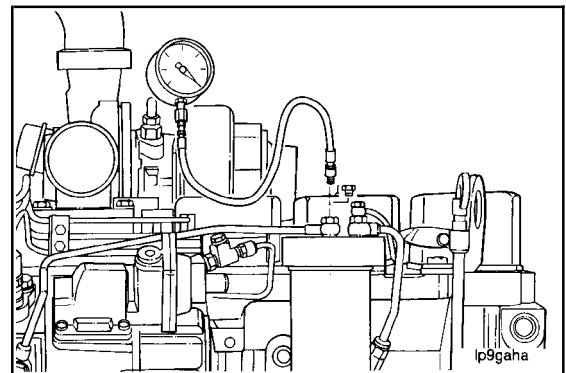

lp9gaha

To be able to unload the compressor, connect a source of compressed air to the unloader (1). This air line **must** contain a valve between the source and the unloader.

**NOTE:** All air compressors manufactured by Cummins Engine Company, Inc. **must** be **loaded** during engine run-in. All air compressors **must** be **unloaded** during the engine performance check.

**NOTE:** The compressed air load in the accompanying illustration **must** be attached to the air compressor outlet (2).

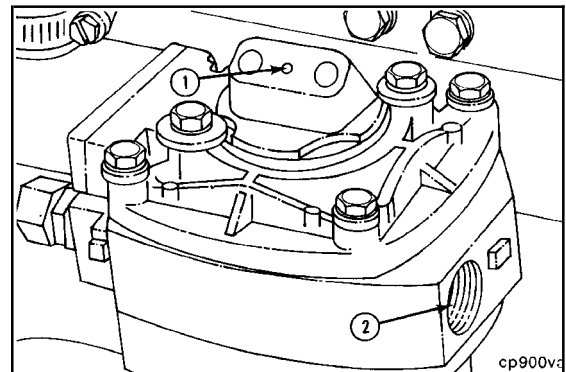

cp900v

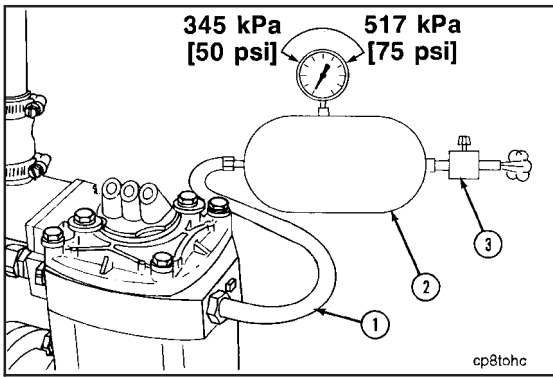

To provide a load on the air compressor, connect an air tank (2) to the compressor outlet; use steel tubing or a high-temperature hose (1).



Install an air regulator (3) that can maintain tank air pressure of 345 kPa to 517 kPa [50 psi to 75 psi] at both the minimum and the maximum engine rpm.

**Hose Temperature (Minimum):**

260 °C [500 °F]

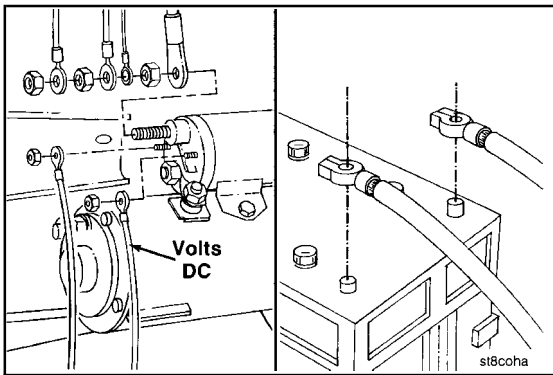

Inspect the voltage rating on the starter motor before installing the electrical wiring.



Attach electrical wires to the starter motor and the batteries if used, negative (-) cable last.



**NOTE:** If another method of starting the engine is used, follow the manufacturer's instructions to make the necessary connections.

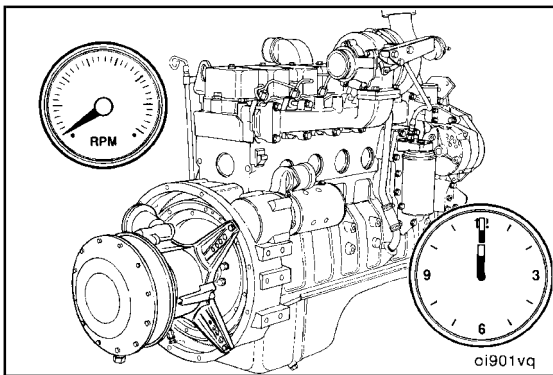

**Engine Run-in (Engine Dynamometer) (014-006)**

**Test (014-006-012)**

The engine run-in period allows the tester to detect assembly errors and to make final adjustments needed for performance that meets specifications.

**NOTE:** The amount of time specified for the following engine run-in phases are minimums. Additional time can be used, if desired, at each phase **except** engine idle periods.

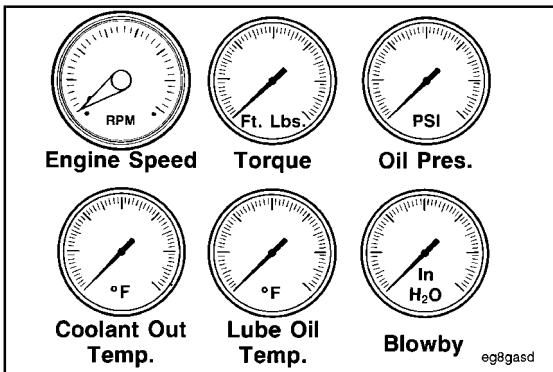

Measurements from these indicators and gauges **must** be observed closely during all phases of the engine run-in period. Refer to the appropriate sections for specifications and acceptable readings.



To evaluate the engine's performance correctly, this additional measurement **must** be observed during engine run-in phases.

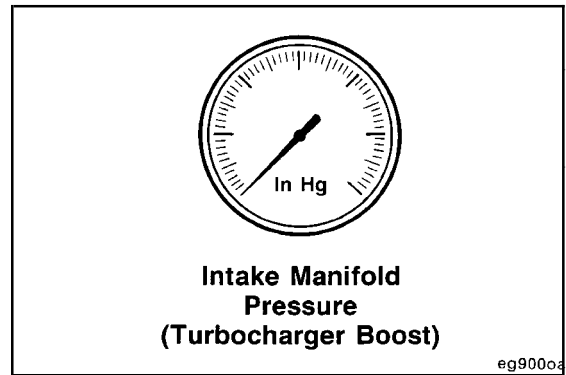

It is good practice to observe these measurements even if engine performance meets specifications. If engine performance does **not** meet specifications, these measurements can indicate possible reasons for nonperformance.

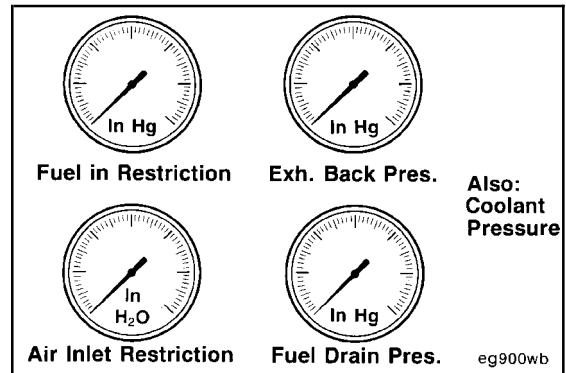

**▲ CAUTION ▲**

**Do not crank the engine for more than 30 seconds. Excessive heat will damage the starting motor.**

Crank the engine and observe the lubricating oil pressure when the engine starts. If the engine fails to start within 30 seconds, allow the starting motor to cool for 2 minutes before cranking the engine again.

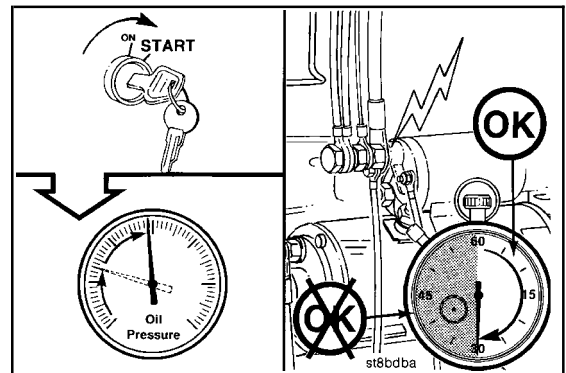

**▲ CAUTION ▲**

**If the lubricating oil pressure is not within specifications, shut off the engine immediately. Low lubricating oil pressure will cause severe engine damage.**

Engine lubricating oil pressure **must** be at least 69 kPa [10 psi] at 700 rpm.

Correct the problem if the lubricating oil pressure is **not** within specifications.

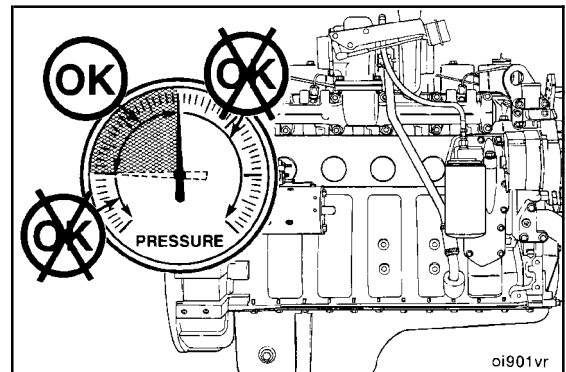

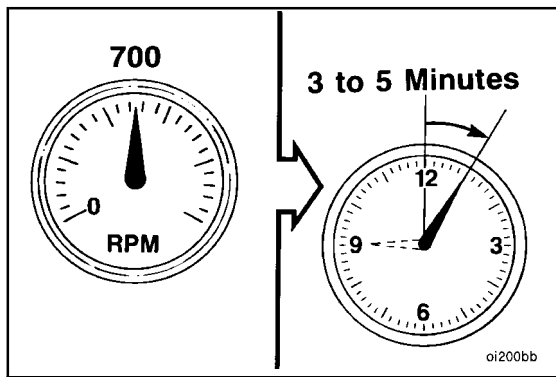

**CAUTION**

Do not operate the engine at idle speed longer than specified during engine run-in. Excessive carbon deposits will form in cylinders, causing damage to the engine.

Operate the engine at approximately 700 rpm for 3 to 5 minutes.

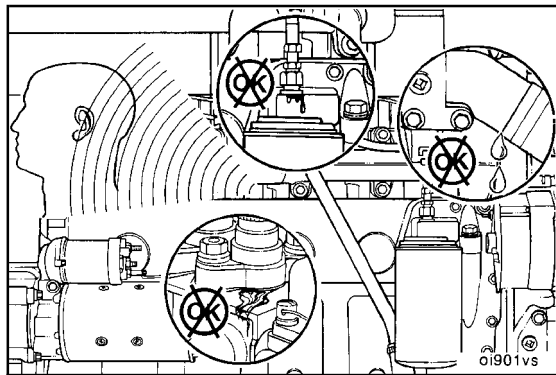

Listen for unusual noise; watch for coolant, fuel, and lubricating oil leaks.

Check for correct engine operation.

**NOTE:** Repair all leaks or component problems before continuing the engine run-in.

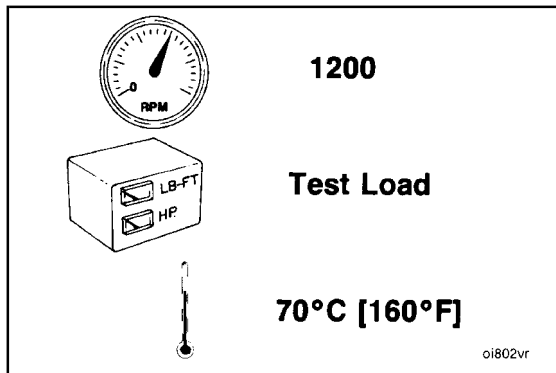

Move the throttle to obtain 1200-rpm engine speed, and set the test load to 25 percent of the rated load.

Operate the engine at this speed and load level until the coolant temperature is 70°C [158°F].

Check all gauges, and record the data.

**NOTE:** Do not proceed to the next step until a steady blowby reading is obtained.

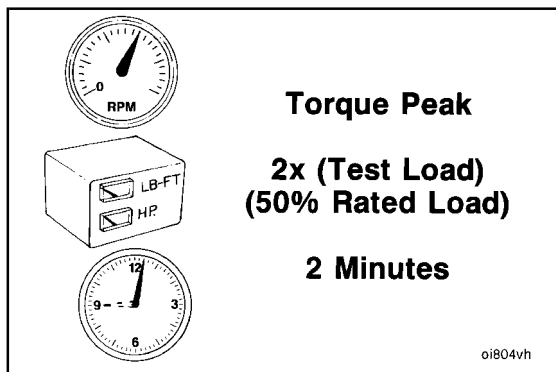

Open the throttle to the speed at which peak torque occurs, and adjust the dynamometer load to 50 percent of torque peak load. Operate the engine at this speed and load level for 2 minutes.

Check all gauges, and record the data.

**NOTE:** Do not proceed to the next step until blowby is stable and within specification.



With the engine speed remaining at torque peak rpm, increase the dynamometer load to 75 percent of torque peak load. Operate the engine at this speed and load level for 2 minutes.

Check all gauges, and record the data.

**NOTE:** Do **not** proceed to the next step until blowby is stable and within specification.



**Torque Peak**  
**3x (Test Load)**  
**(75% Rated Load)**  
**2 Minutes**

oi804vi

Move the throttle lever to its full capacity in the opened position, and increase the dynamometer load until the engine speed is at torque peak rpm. Operate the engine at this speed and load level for 10 minutes, or until the blowby becomes stable and within specification.

Check all gauges, and record the data.



**Full Throttle Torque Peak**  
**Maximum Load**  
**10 Minutes**

oi804vj

Reduce the dynamometer load until the engine speed increases to the engine's rated rpm.

Operate the engine at rated rpm for 5 minutes.

Check all gauges, and record the data.



**Full Throttle Rated**  
**Maximum Load at Rated Speed**  
**5 Minutes**

oi804vk

**▲ CAUTION ▲**

**Shutting off the engine immediately after operating at full load will damage the turbocharger and internal components. Always allow the engine to cool before shutting it off.**

Remove the dynamometer load completely, and operate the engine at 700 rpm for 3 to 5 minutes. This period will allow the turbocharger and other components to cool.



**700**  
**3 to 5 Minutes**

oi804vl

Shut off the engine.

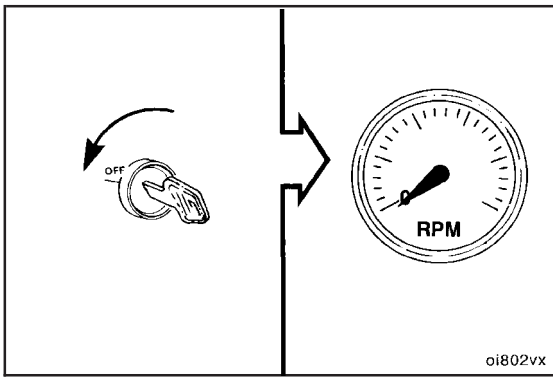

oi802vx

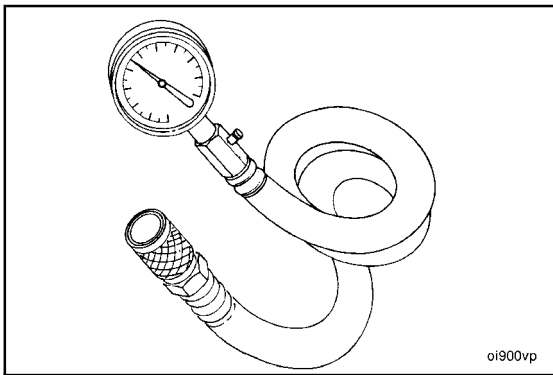

oi900vp



### Engine Testing (In Chassis) (014-008) Initial Check (014-008-001)

It is very time consuming and expensive to remove internal engine components to diagnose failures. A compression gauge and adapter can be used as an aid in checking for failures.

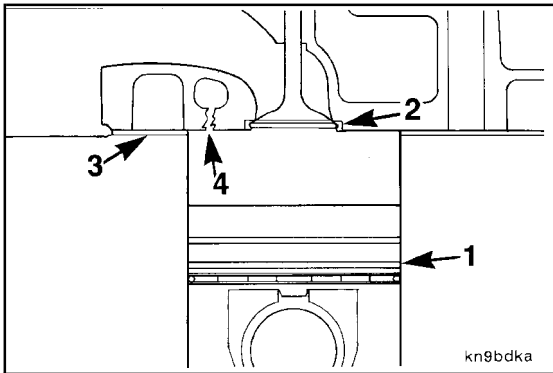

kn9bdka



Use the compression gauge and adapter to check for following component failures:

1. Piston ring sealing
2. Intake and exhaust valve sealing
3. Cylinder head gasket sealing
4. Cylinder head cracked.

Refer to the appropriate procedures for the replacement of failed components.

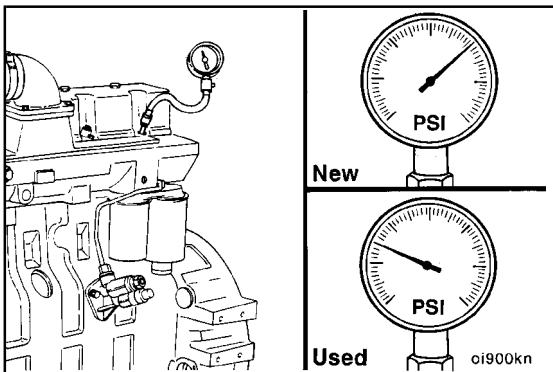

oi900kn



**NOTE:** Due to variables such as starter and battery conditions that affect engine cranking speed, it is difficult to establish an absolute value for compression pressure; however, the following values can be used as guidelines:

- New engine (cranking speed @ 250 rpm) 2413 kPa [350 psi]
- Used engine (cranking speed @ 250 rpm) 2068 kPa [300 psi].

It is recommended that the compression pressure be checked on all cylinders and then compared to specification. All cylinders **must** be within 690 kPa [100 psi] of each other.

**Piston Ring Sealing**

If the compression is low but can be increased significantly by squirting oil into the cylinder, the cause is inadequate sealing between the rings and the cylinder walls.

Refer to Procedure 001-047 for piston ring replacement.

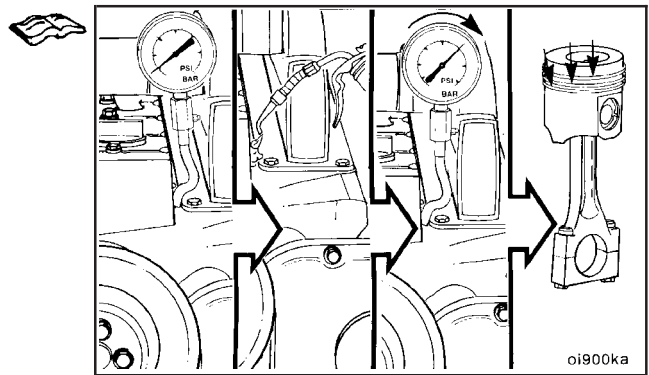

**Intake and Exhaust Valve Sealing**

If the compression is low on one or more nonadjacent cylinders, and the pressure can **not** be increased by oiling the rings, poor valve sealing is suspected.

Refer to Procedure 002-004 for cylinder head replacement.

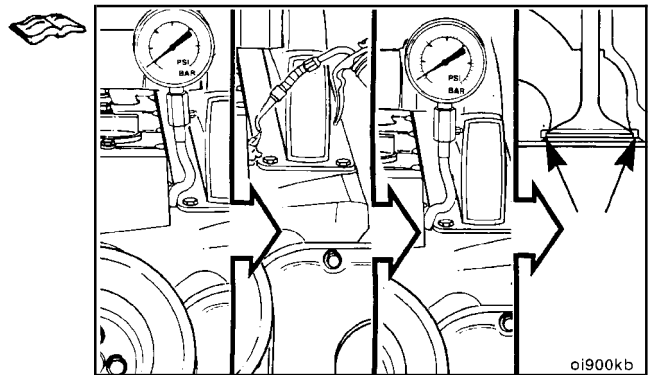

Valve leakage is often an audible sound from the intake and exhaust manifolds.

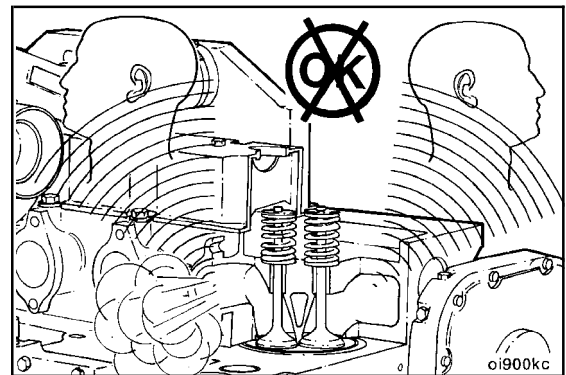

**Cylinder Head Gasket Sealing**

If the compression is low on adjacent cylinders, and the pressure can **not** be increased by oiling the rings, the cylinder head gasket is probably leaking between the cylinders.

Refer to Procedure 002-021 for cylinder gasket replacement.

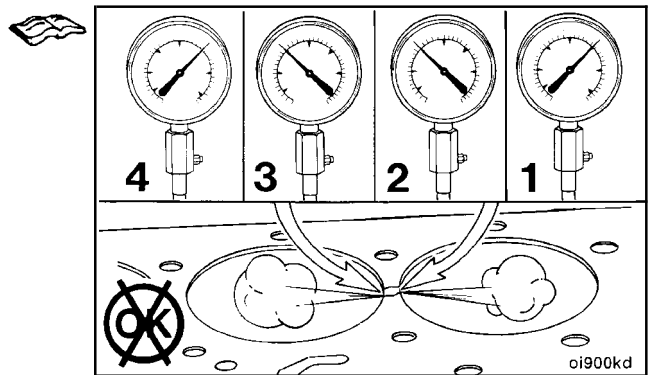

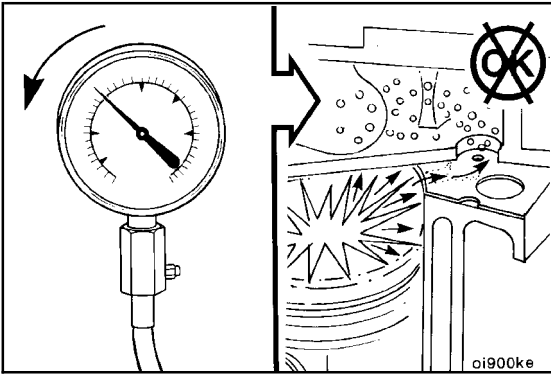

**NOTE:** Low compression on a single cylinder can be caused by an external leak or a leak to a coolant passage. A leak to a coolant passage of this magnitude will also result in coolant in the cylinder.

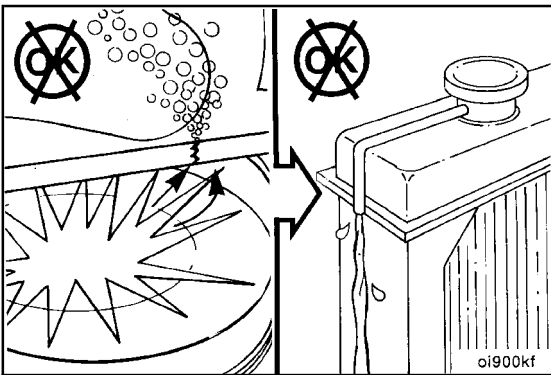

A compression leak to the coolant will normally be detected by a loss of coolant as the coolant is blown from the cooling system.



**Service Tip:** Remove the drive belt from the water pump. Refer to Procedure 008-002 for removal and installation of drive belt.



Run the engine for 1 to 2 minutes, and check for coolant being blown from the radiator by compression gases.

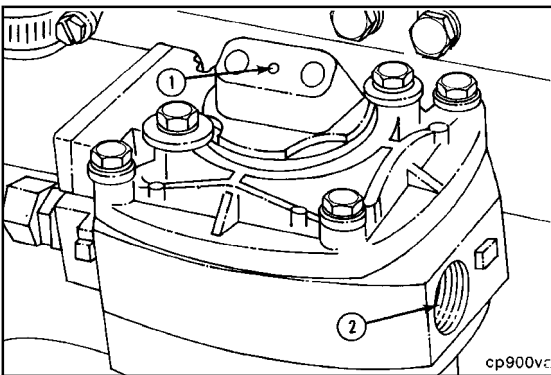

**Test (014-008-012)**

**NOTE:** The compressed air load in the accompanying illustration **must** be attached to the air compressor outlet (2).

Make sure the air compressor will be unloaded during the performance check.

Apply regulated air pressure of 655 kPa [95 psi] to the air compressor unloader (1).

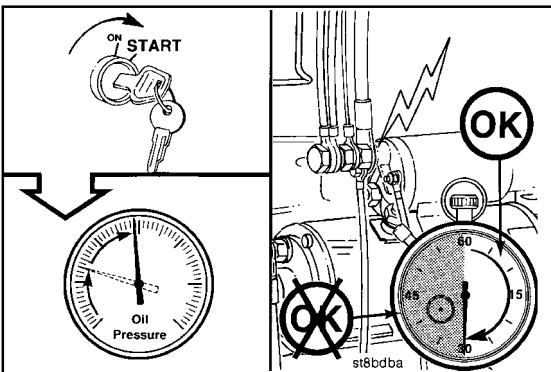

**CAUTION**

**Do not crank the engine for more than 30 seconds. Excessive heat will damage the starting motor.**

Crank the engine and observe the oil pressure when the engine starts. If the engine fails to start within 30 seconds, allow the starting motor to cool for 2 minutes before cranking the engine again.

**CAUTION**

If the lubricating oil pressure is not within specifications, shut off the engine immediately. Low lubricating oil pressure will cause engine damage. Correct the problem if lubricating oil pressure is not within specifications.

Engine lubricating oil pressure **must** be at least 69 kPa [10 psi] at approximately 700 rpm.

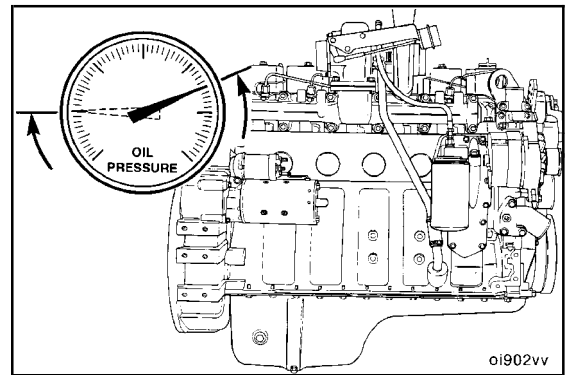

**NOTE:** The horsepower readings will **not** be accurate if the lubricating oil temperature and fuel temperature are **not** within specifications.

Make sure the engine is at operating temperature.

Move the throttle lever to the FULL-OPEN position. Adjust the dynamometer load until the engine maintains the rated rpm.

Allow the readings to stabilize. Read the horsepower.

Check all gauges, and record the readings.

**Lubricating Oil Temperature**

90 °C [194 °F]

**Fuel Temperature**

32 °C [90 °F]

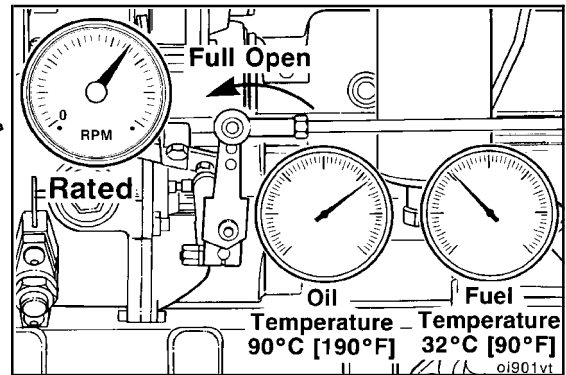

**CAUTION**

Do not shut off the engine immediately after it has been loaded. It must be allowed to cool sufficiently. Failure to do so will result in engine damage.

**NOTE:** Idle periods longer than 5 minutes are to be avoided.

Remove the dynamometer load completely, and operate the engine at idle speed for 3 to 5 minutes. This will allow the turbocharger and other components to cool.

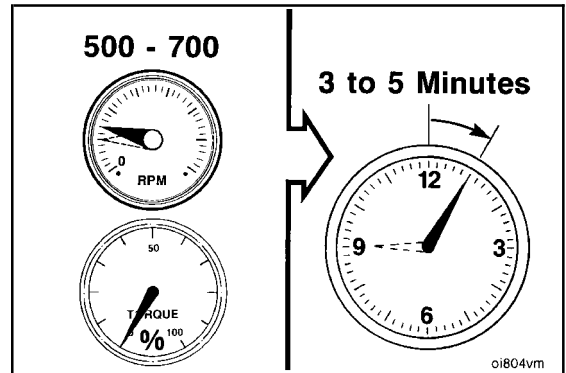

Shut off the engine after the cooldown period.

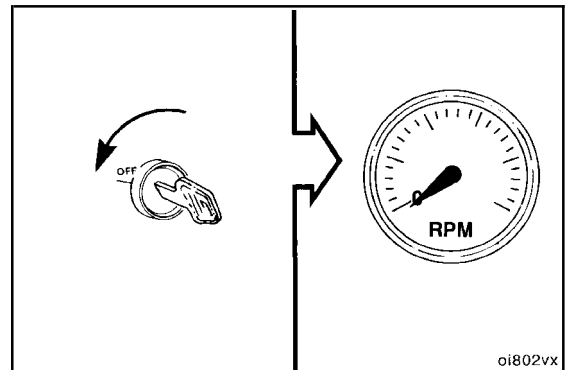

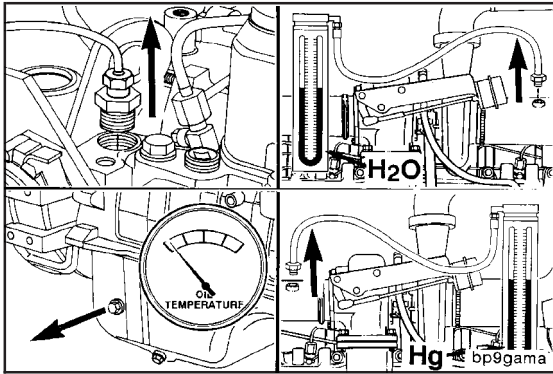

**NOTE:** If the engine is to be stored temporarily and does **not** have permanent-type antifreeze, it is necessary to drain all coolant.

Remove all test instrumentation.

Remove the engine from the dynamometer.

### Crankcase Blowby, Measure (014-010)

#### Measure (014-010-010)

Refer to the table below for 4B engines' blowby\*\* at given speed at 100-percent load.

Rated Speed	New L/min	Worn L/min
4B @ 2200	18	36
4B @ 2500	20	40
4B @ 2800	23	46
4BT @ 2200	45	90
4BT @ 2500	51	102
4BT @ 2800	57	114

\*\* Blowby checking tool, Cummins Part No. 3822476, has a special 5.613-mm [0.221-in] orifice that **must** be used to get an accurate reading.

Refer to the table below for 6B engines' blowby\*\* at given speed at 100-percent load.

Rated Speed	New L/min	Worn L/min
6B @ 2200	26	52
6B @ 2500	30	60
6B @ 2800	34	68
6BT @ 2200	63	126
6BT @ 2500	76	152
6BT @ 2800	85	170

\*\* Blowby checking tool, Cummins Part No. 3822476, has a special 5.613-mm [0.221-in] orifice that **must** be used to get an accurate reading.

#### Blowby conversion chart 5.613-mm [0.221-in] orifice.

Inches of Water	Liters/Minute	Inches of Water	Liters/Minute
1	27	19	121
2	40	20	124
3	58	22	131
5	64	23	135
6	71	24	137
7	76	25	140
8	81	26	144
9	86	27	147
10	90	28	150
11	94	29	154
12	98	30	157
13	102	31	160
14	105	32	163
15	109	33	166
16	112	34	169
17	115	35	172
18	118		





# Section 16 - Mounting Adaptations - Group 16



## Section Contents

	Page
<b>Engine Mounts</b> .....	16-23
Inspect for Reuse .....	16-23
<b>Engine Support Bracket, Front</b> .....	16-3
Clean .....	16-3
Inspect for Reuse .....	16-3
Install .....	16-4
Remove.....	16-3
<b>Engine Support Bracket, Rear</b> .....	16-4
Clean .....	16-5
Inspect for Reuse .....	16-5
Install .....	16-5
Remove.....	16-4
<b>Flywheel</b> .....	16-6
Clean .....	16-7
Inspect for Reuse .....	16-7
Install.....	16-11
Measure .....	16-8
Remove.....	16-6
<b>Flywheel Housing</b> .....	16-13
Clean .....	16-14
Inspect for Reuse .....	16-15
Install .....	16-18
Measure .....	16-15
Remove.....	16-13
<b>Flywheel Ring Gear</b> .....	16-21
Initial Check .....	16-22
Install .....	16-22
Preparatory.....	16-21
Remove.....	16-22
<b>Service Tools</b> .....	16-1
Mounting Adaptations .....	16-1

**THIS PAGE LEFT INTENTIONALLY BLANK**

## Service Tools Mounting Adaptations

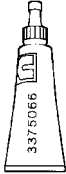
The following special tools are recommended to perform procedures in this section. The use of these tools is shown in the appropriate procedure. These tools can be purchased from your local Cummins Authorized Repair Location.

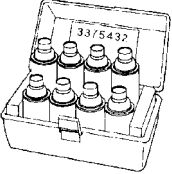
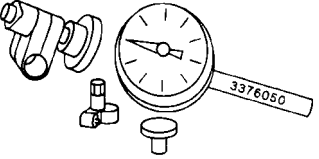
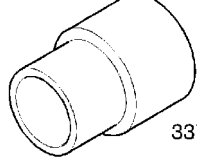
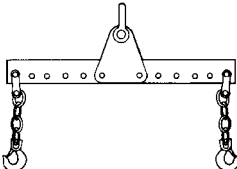
Tool No.	Tool Description	Tool Illustration
3375066	<b>Pipe Sealant</b> Used on capscrew threads and pipe plugs.	 <p style="text-align: right;">3375066</p>
3375068	<b>Cup Plug Sealant</b> Used when installing cup plugs.	 <p style="text-align: right;">3375068</p>
3375432	<b>Crack Detection Kit</b> Used to detect cracks in engine components.	 <p style="text-align: right;">3375432</p>
3376050	<b>Dial Indicator Gauge</b> Used for checking flywheel housing runout and/or checking end play on various components.	 <p style="text-align: right;">3376050</p>
3376812	<b>Cup Plug Driver</b> Used to install cup plug in flywheel housing.	 <p style="text-align: right;">3376812</p>
3822512	<b>Engine Lifting Fixture</b> Used to remove and install the engine.	 <p style="text-align: right;">3822512</p>

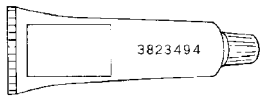
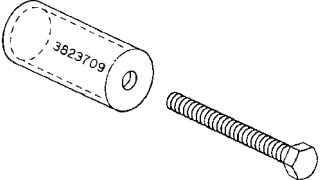
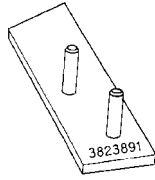
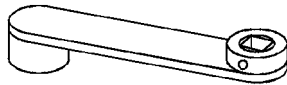
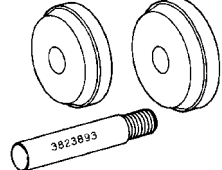
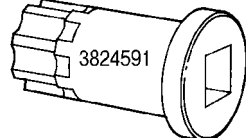
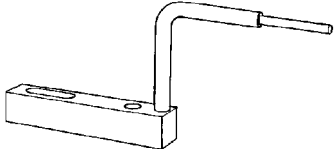
Tool No.	Tool Description	Tool Illustration
3823494	<p><b>Three-Bond™ Sealant</b> Used on heavy-duty silicone-type cup plugs.</p>	 <p>3823494</p>
3823709	<p><b>Idler Shaft Puller and Capscrew</b> Used to remove idler shaft from idler gear and flywheel housing.</p>	 <p>3823709</p>
3823891	<p><b>Gear Locking Tool</b> Used to prevent rotation of the power take-off output shaft while tightening the output flange capscrew.</p>	 <p>3823891</p>
3823892	<p><b>Offset Wrench</b> Used to tighten the hidden capscrews in the REPTO flywheel housing.</p>	 <p>3823892</p>
3823893	<p><b>Bearing Race Driver</b> Used to install output shaft bearing races.</p>	 <p>3823893</p>
3824591	<p><b>Barring Tool</b> Used to engage the flywheel ring gear to rotate the crankshaft.</p>	 <p>3824591</p>
ST-1325	<p><b>Dial Gauge Attachment</b> Used to mount on the crankshaft flange when checking flywheel housing runout.</p>	 <p>ST-1325</p>

### Engine Support Bracket, Front (016-002)

#### Remove (016-002-002)

Use a hoist or lifting fixture to support the front of the engine.

Remove the capscrews from the front engine mount.

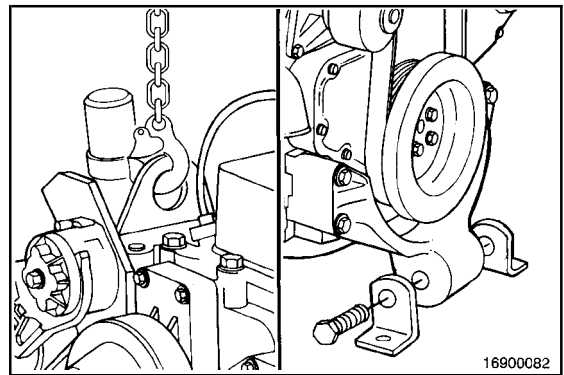

Remove the four mounting capscrews and the front engine support.

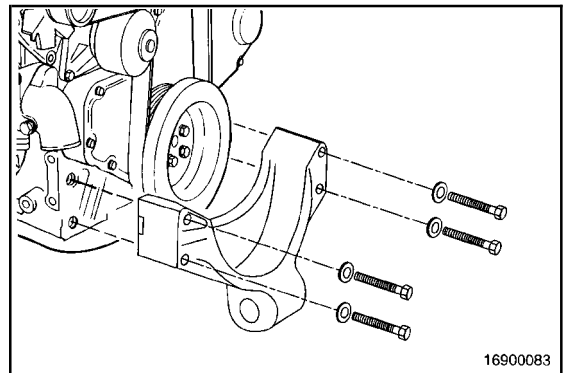

#### Clean (016-002-006)



When using a steam cleaner, wear protective clothing, and safety glasses or a face shield. Hot steam can cause serious personal injury.



Wear appropriate eye and face protection when using compressed air. Flying debris and dirt can cause bodily injury.

Use steam or solvent to clean the front engine support.

Dry with compressed air.

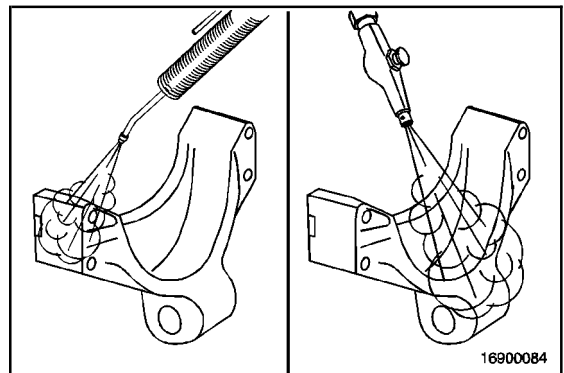

#### Inspect for Reuse (016-002-007)

Inspect the support for cracks or damage.

If the support is cracked, it **must** be replaced.

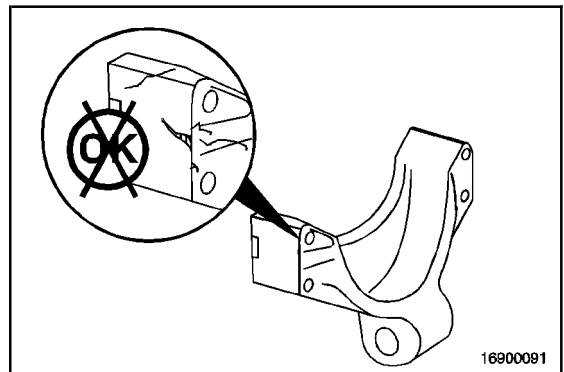

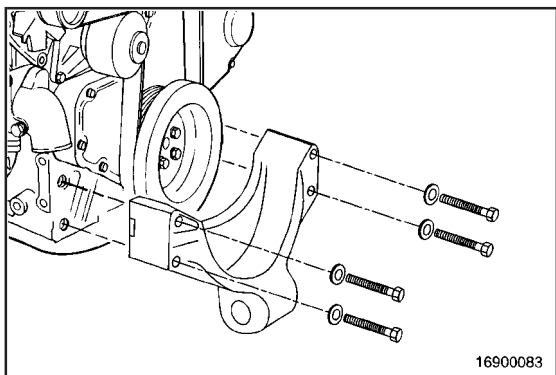

**Install (016-002-026)**

Install the front support and mounting capscrews.

**Torque Value:** 68 N•m [50 ft-lb]

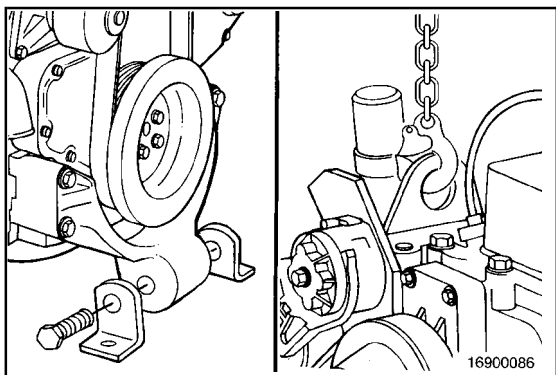

Lower the front of the engine.

Install the front engine mount capscrews.

Tighten the capscrews to the manufacturer's specifications.



Remove the lifting fixture or hoist from the front of the engine.

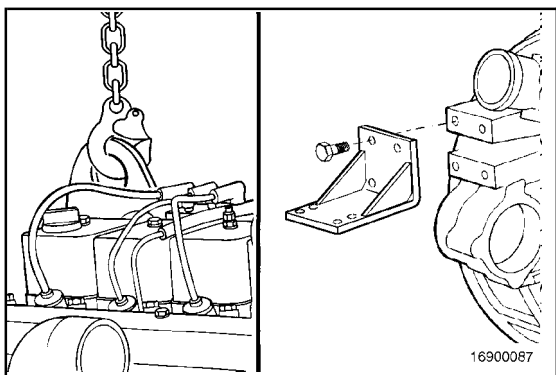

**Engine Support Bracket, Rear (016-003)**

**Remove (016-003-002)**

Use a hoist or lifting fixture to support the rear of the engine.

Remove the capscrew from the rear engine mount.

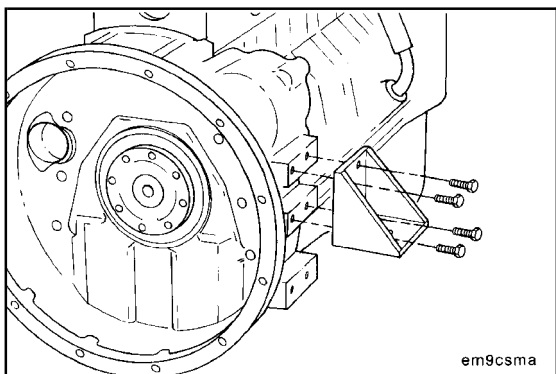

Remove the four capscrews and rear support bracket.

**Clean (016-003-006)**

**▲ WARNING ▲**

When using a steam cleaner, wear safety glasses or a face shield, as well as protective clothing. Hot steam can cause serious personal injury.

**▲ WARNING ▲**

Wear appropriate eye and face protection when using compressed air. Flying debris and dirt can cause bodily injury.

Use steam or solvent to clean the front engine support.

Dry with compressed air.

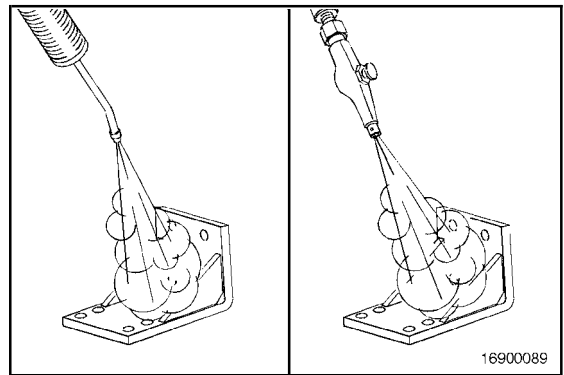

**Inspect for Reuse (016-003-007)**

Inspect the support bracket for cracks or damage.

If the support bracket is cracked, it **must** be replaced.

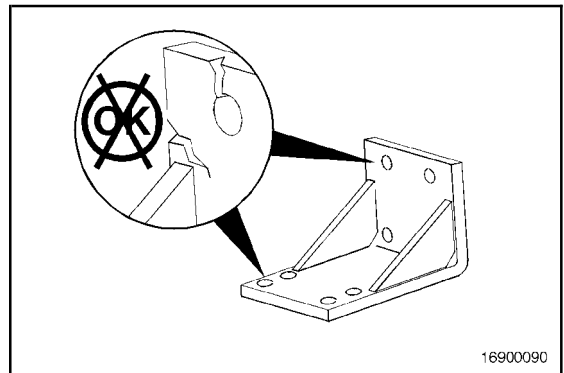

**Install (016-003-026)**

Install the support bracket and mounting capscrews.

**Torque Value:** 71 N•m [52 ft-lb]

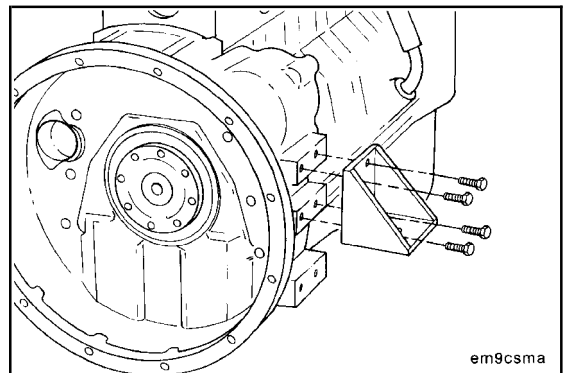

Lower the rear of the engine.

Install the rear engine mount capscrews.

Tighten to the manufacturer's specifications.

Remove the lifting fixture or hoist from the rear of the engine.

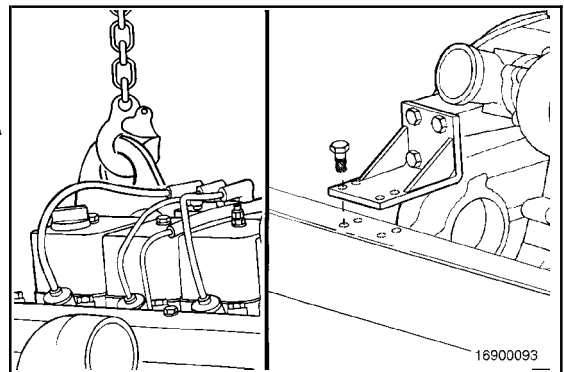

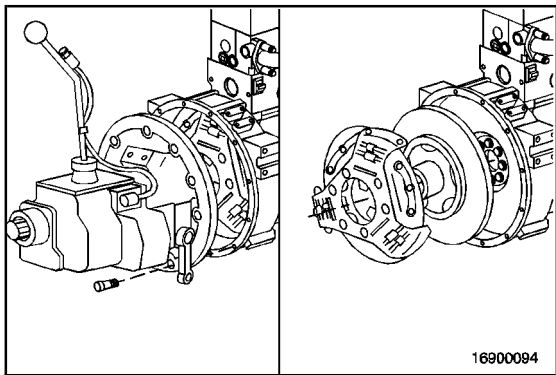

16900094

### Flywheel (016-005)

#### Remove (016-005-002)



#### Barring Tool, Part No. 3824591

Remove the vehicle driveline and transmission. Refer to the manufacturer's instructions.



Remove the clutch discs and the pressure plate. Refer to the manufacturer's instructions.

**NOTE:** Use the barring tool, Part No. 3824591, to hold the flywheel to prevent rotation.

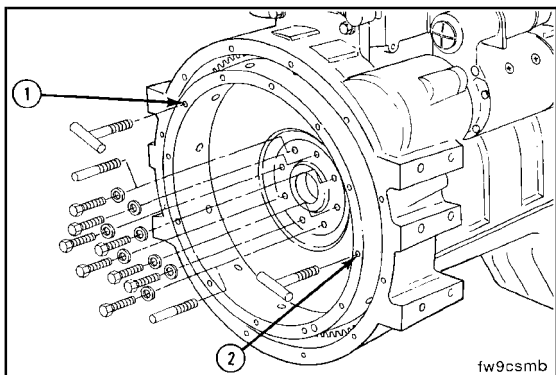

fw9csmb



Remove two cap screws 180 degrees apart.

Install two M12 x 1.25 x 90-mm guide pins.



**NOTE:** If a clutch is used in the equipment, the threads in the clutch pressure plate mounting cap screw holes can be metric or standard. Be **sure** to use the correct cap screws.



Determine the cap screw thread design and size, and install two t-handles in the flywheel at points (1 and 2).

Remove the remaining six flywheel mounting cap screws.

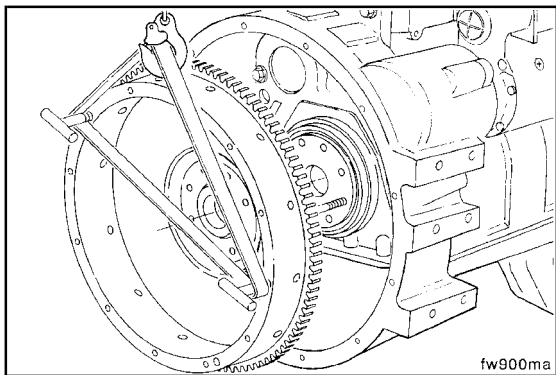

fw900ma



### ▲ WARNING ▲

The component weighs 23 kg [51 lb] or more. To avoid personal injury, use a hoist or get assistance to lift the component.



Remove the flywheel from the guide pins.



**Clean (016-005-006)**

**⚠ WARNING ⚠**

When using a steam cleaner, wear safety glasses or a face shield, as well as protective clothing. Hot steam can cause serious personal injury.

**⚠ WARNING ⚠**

When using solvents, acids, or alkaline materials for cleaning, follow the manufacturer's recommendations for use. Wear goggles and protective clothing to avoid personal injury.

**⚠ WARNING ⚠**

Compressed air used for cleaning should not exceed 207 kPa [30 psi]. Wear appropriate eye and face protection when using compressed air. Flying debris and dirt can cause bodily injury.

Use a wire brush to clean the crankshaft pilot bore.

Use steam or solvent to clean the flywheel.

Dry with compressed air.

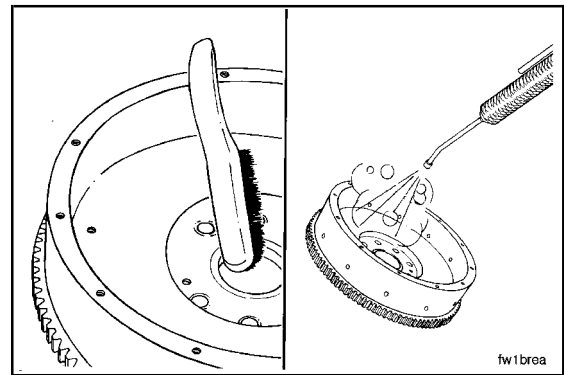

fw1brea

**Inspect for Reuse (016-005-007)**

Inspect for nicks or burrs.

Use Scotch-Brite™ 7448, or equivalent, to remove small nicks and burrs.

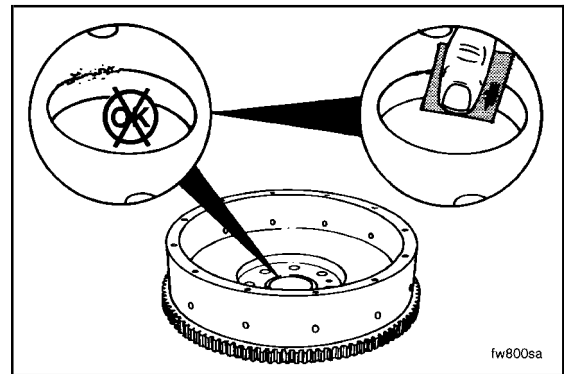

fw800sa

**⚠ WARNING ⚠**

Do not use a cracked or resurfaced flywheel. These can break, causing serious personal injury or property damage.

**Crack Detection Kit, Part No. 3375432**

Use the crack detection kit, Part No. 3375432, to check for cracks in the flywheel. Follow the instructions provided with the kit.

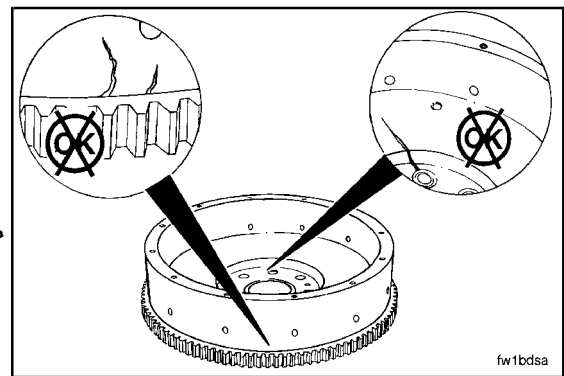

fw1bdsa

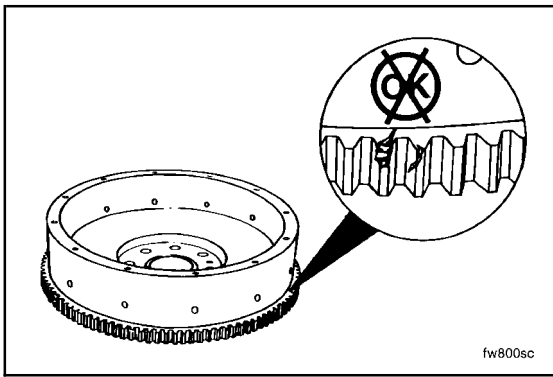

Inspect the flywheel ring gear teeth for cracks and chips.

**NOTE:** If the ring gear teeth are cracked or broken, the ring gear **must** be replaced. Refer to Procedure 016-008.

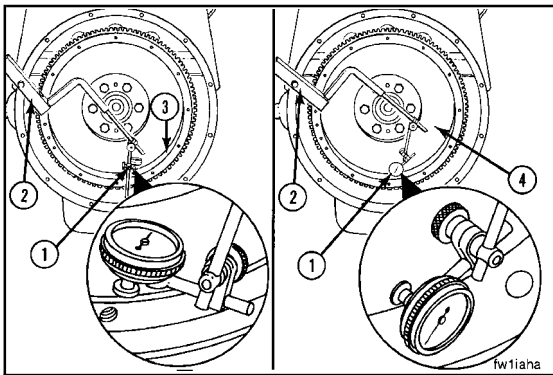

**Measure (016-005-010)**

**Flywheel Bore Runout**



**Indicator Gauge, Part No. 3376050**

**Dial Gauge Attachment, Part No. ST-1325**



Use the dial indicator gauge (1), Part No. 3376050, or its equivalent, and dial gauge attachment (2), Part No. ST-1325, to inspect the flywheel bore (3) and the surface (4) runout.

Install the attachment to the flywheel housing.

Install the gauge on the attachment.

Install the contact tip of the indicator against the inside diameter of the flywheel bore, and set the dial indicator at zero.

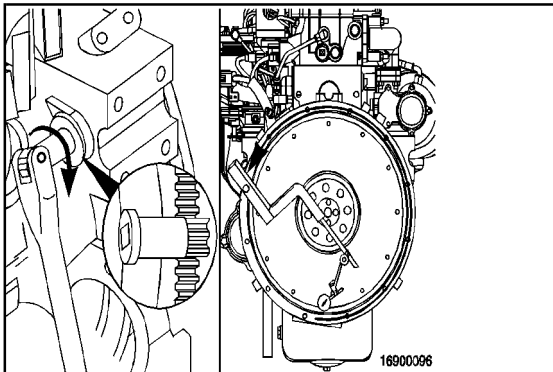

**Barring Tool, Part No. 3824591**

Use the barring tool, Part No. 3824591, to rotate the crankshaft one complete revolution.



**NOTE:** The total indicator reading (TIR) **must not** exceed 0.127 mm [0.0050 in].

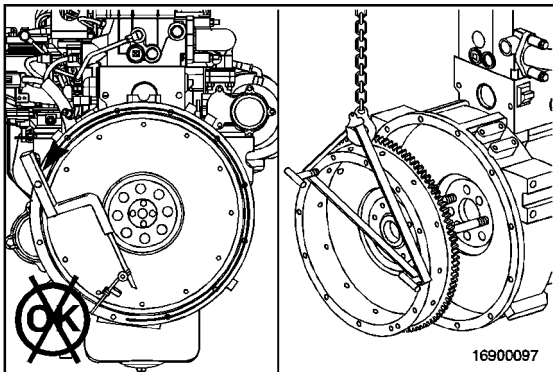

**▲ WARNING ▲**

The component weighs 23 kg [51 lb] or more. To avoid personal injury, use a hoist or get assistance to lift the component.



**NOTE:** If the total indicator reading (TIR) is greater than the specification, do the following:

- Remove the flywheel.

- Inspect the flywheel mounting surface for dirt or damage.

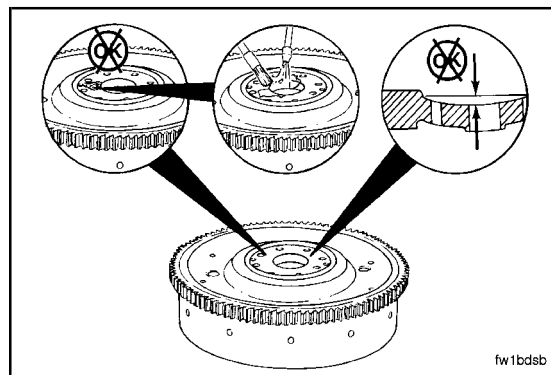

fw1bdsb

- Inspect the crankshaft for dirt or damage.

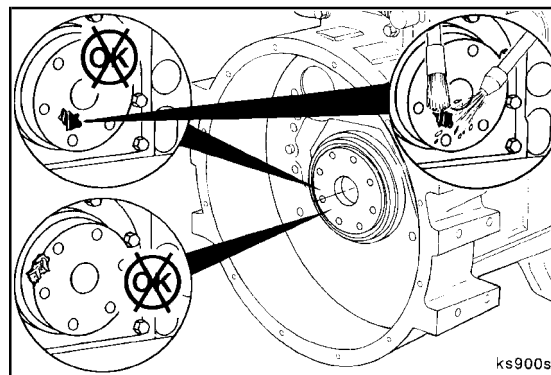

ks900st

**▲ WARNING ▲**

The component weighs 23 kg [51 lb] or more. To avoid personal injury, use a hoist or get assistance to lift the component.

- Install the flywheel.
- Inspect the bore runout again.

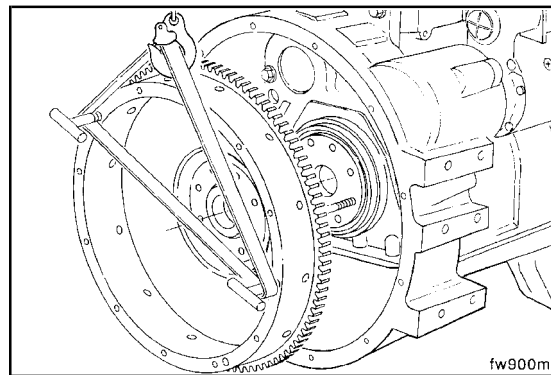

fw900ma

- Replace the flywheel if the runout does **not** meet specifications.



Flywheel Bore Runout		
mm		in
0.127	MAX	0.005

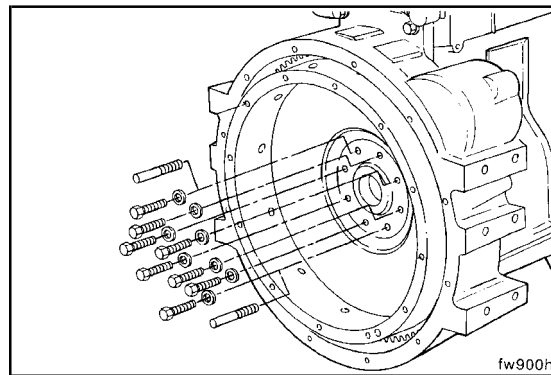

fw900he

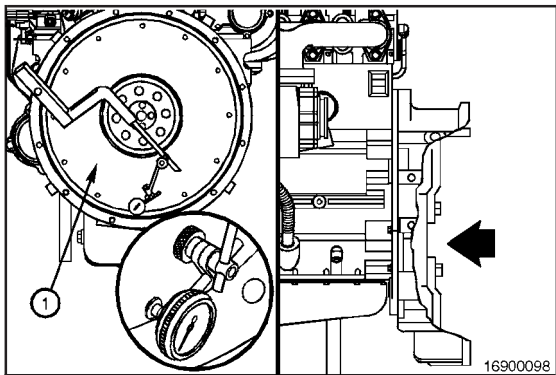

**Flywheel Face Runout**

Install the contact tip of the indicator against the flywheel face, as close to the outside diameter as possible, to inspect the face (1) runout.



**NOTE:** Push the flywheel forward to remove the crankshaft end clearance. Adjust the dial on the indicator until the needle points to zero.

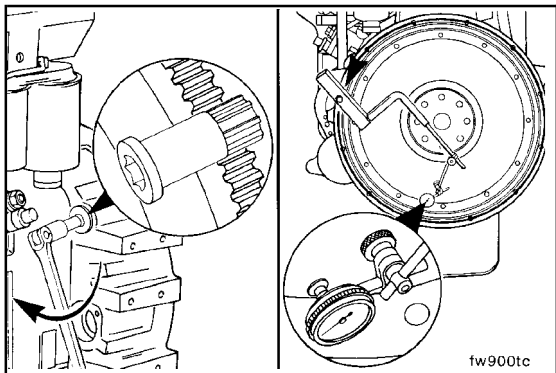

**Barring Tool, Part No. 3824591**

Use the barring tool, Part No. 3824591, to rotate the crankshaft one complete revolution. Measure the flywheel runout at four equal points on the flywheel.



**NOTE:** The flywheel **must** be pushed toward the front of the engine to remove the crankshaft end clearance each time a point is measured.

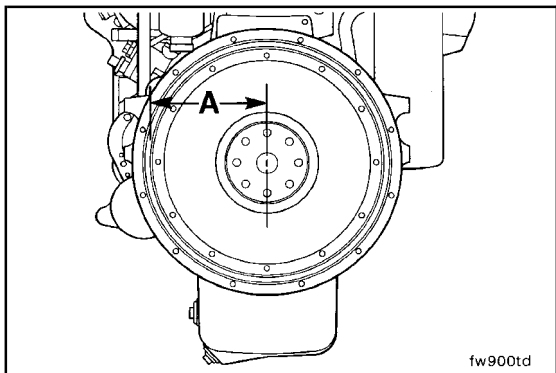

The total indicator reading (TIR) **must not** exceed the following specifications:

Flywheel Radius (A)		Maximum of Flywheel Face	
mm	in	mm	in
203	8	0.203	0.008
254	10	0.254	0.010
305	12	0.305	0.012
356	14	0.356	0.014
406	16	0.406	0.016

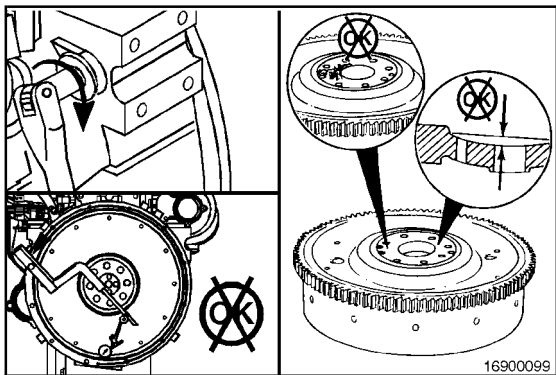

If the flywheel face runout is **not** within specifications, remove the flywheel. Check for nicks, burrs, or foreign material between the flywheel mounting surface and the crankshaft flange.



**B3.9 and B5.9 Series Engines  
Section 16 - Mounting Adaptations - Group 16**

Install the clutch discs, pressure plate, transmission, and driveline (if equipped) in reverse order of removal. Refer to the manufacturer's instructions.

**NOTE:** Align the universal joints on each end of the driveshaft to prevent vibration.

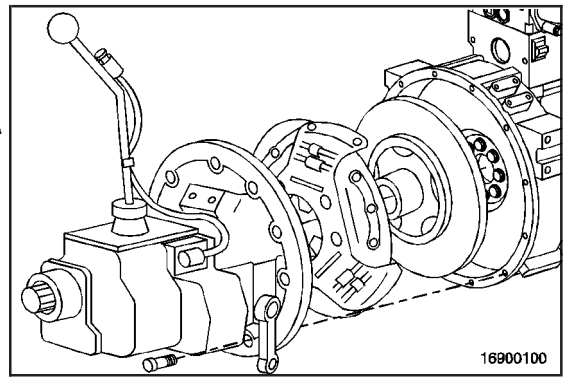

**Install (016-005-026)**

**NOTE:** Use a new pilot bearing when installing a new or rebuilt clutch.

Use a mandrel and hammer to remove the pilot bearing.

Use a Scotch-Brite™ 7448, or equivalent, to clean the pilot bore.

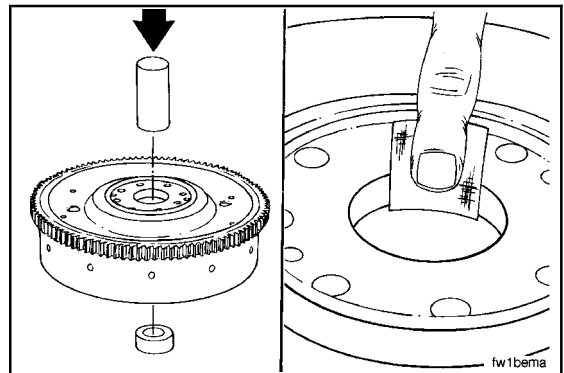

Use a mandrel and hammer to install the pilot bearing.

**NOTE:** The pilot bearing **must** be installed evenly with the pilot bore surface.

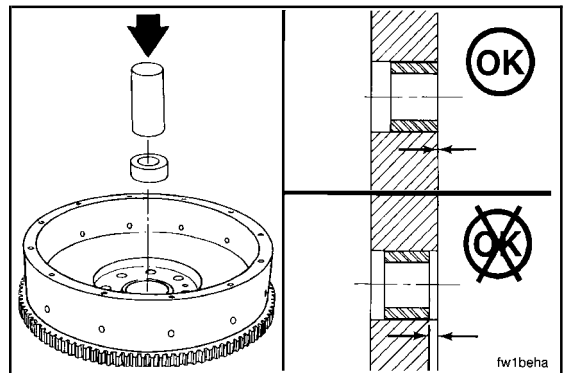

Install two M12 x 1.25 x 90-mm guide pins into the crankshaft flange 180 degrees apart.

**NOTE:** If a clutch is used in the equipment, the threads in the clutch pressure plate mounting capscrew holes can be metric or standard. Be **sure** to use the correct capscrews.

Determine the capscrew thread design and size, and install two t-handles into the flywheel (at points 1 and 2).

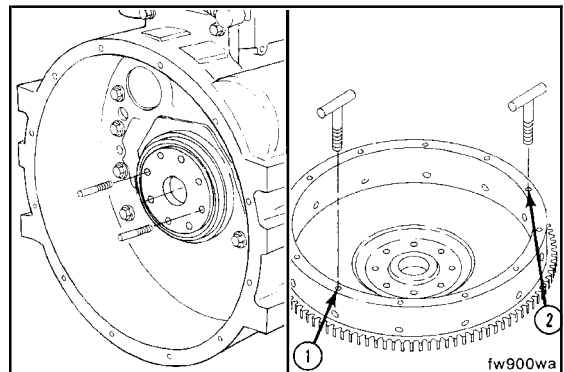

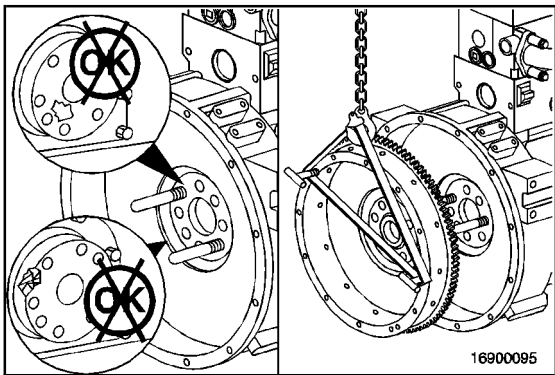

**▲ WARNING ▲**

The component weighs 23 kg [51 lb] or more. To avoid personal injury, use a hoist or get assistance to lift the component.



Inspect the rear face of crankshaft and flywheel mounting flange for cleanliness and raised nicks or burrs.



Install the flywheel on the guide pins.

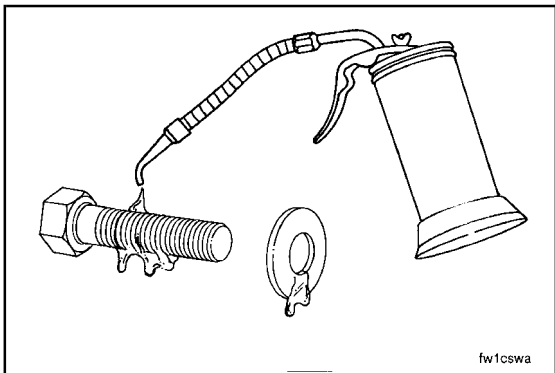

Lubricate the threads of the capscrews and the surface of the washers with clean lubricating engine oil.

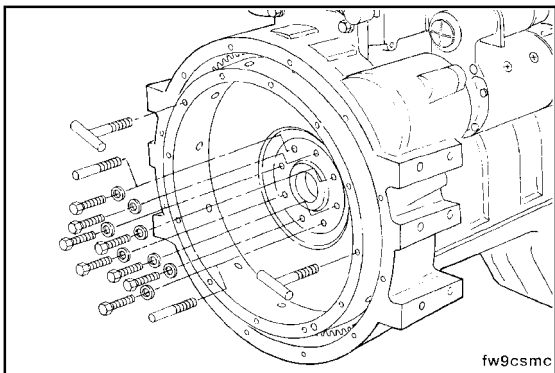

Install the six capscrews.

Remove the t-handles and guide pins.



Install the remaining capscrews into the holes from which the guide pins were removed.

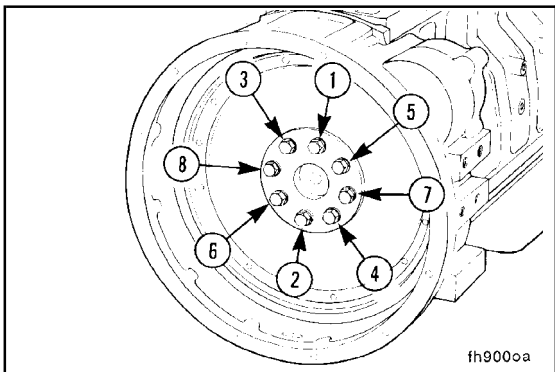

18 mm

**Barring Tool, Part No. 3824591**



Hold the crankshaft when tightening the flywheel capscrews.

Tighten the capscrews in a star pattern.



**Torque Value:** 137 N•m [101 ft-lb]

Refer to the equipment manufacturer's procedures to install the transmission.

### Flywheel Housing (016-006)

#### Remove (016-006-002)

Remove the transmission, clutch, and all related components (if equipped). Refer to the manufacturer's instructions.

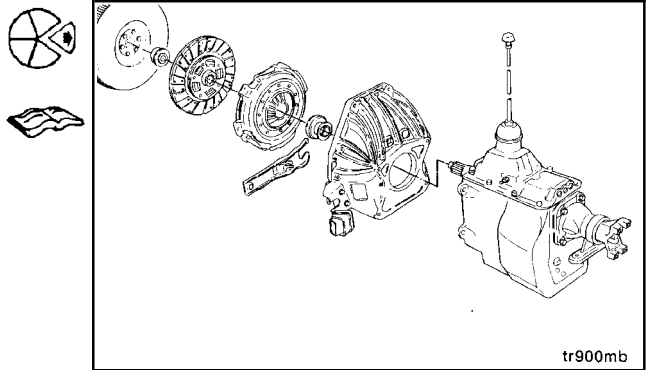

**⚠ WARNING ⚠**

The component weighs 23 kg [51 lb] or more. To avoid personal injury, use a hoist or get assistance to lift the component.

Remove the flywheel/ring gear assembly. Refer to Procedure 016-005.

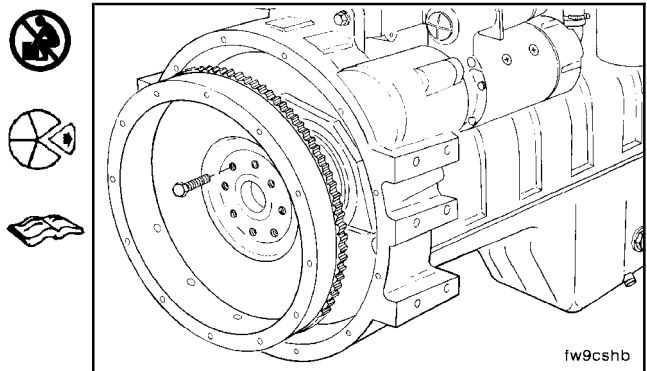

Adequately support the engine to prevent damage.

Disconnect the battery cables.

Remove the starter motor.

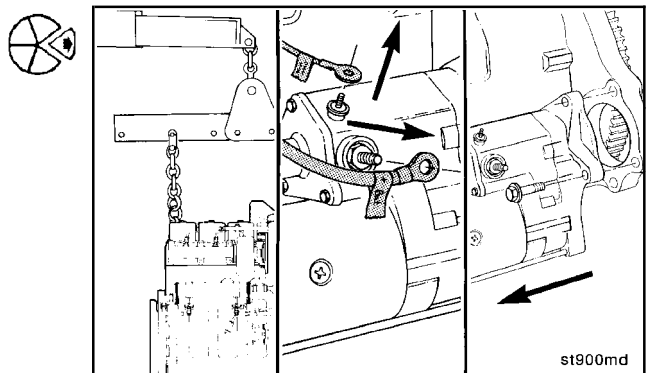

Remove the capscrews and both rear engine mounts.

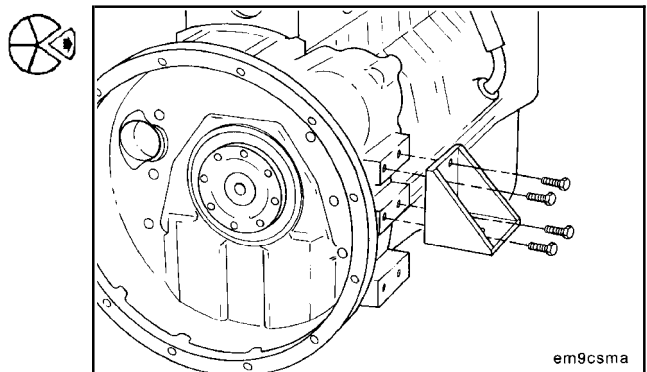

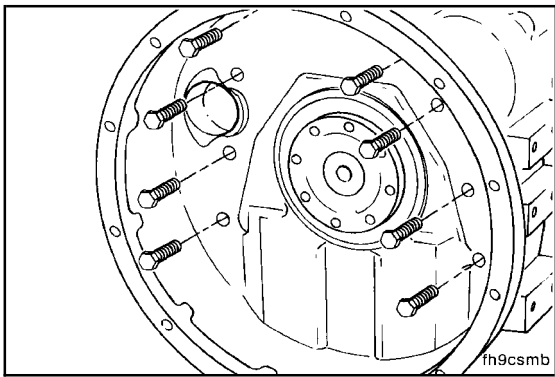

**▲ WARNING ▲**

The component weighs 23 kg [51 lb] or more. To avoid personal injury, use a hoist or get assistance to lift the component.



While supporting the flywheel housing, remove the mounting capscrews.

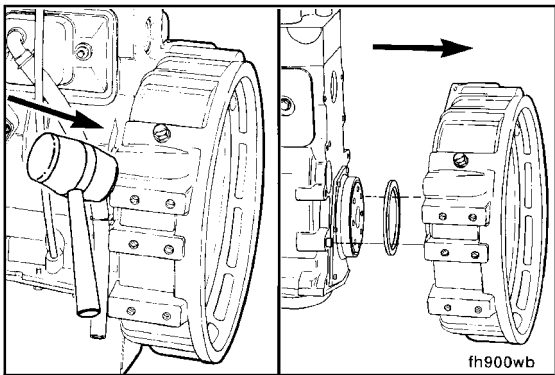

Use a rubber hammer to loosen the flywheel housing. Remove the flywheel housing and rectangular seal.

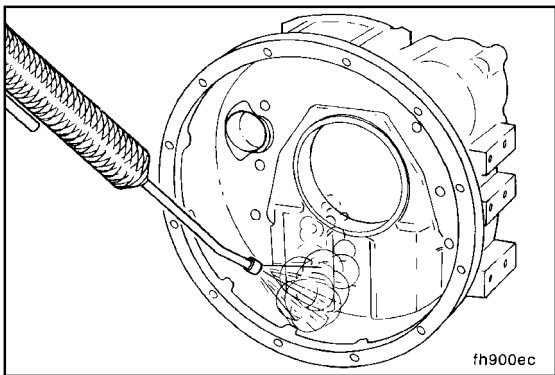

**Clean (016-006-006)**

**▲ WARNING ▲**

When using a steam cleaner, wear protective clothing, as well as safety glasses or a face shield. Hot steam can cause serious personal injury.

**▲ WARNING ▲**

When using solvents, acids, or alkaline materials for cleaning, follow the manufacturer's recommendations for use. Wear goggles, as well as protective clothing, to avoid personal injury.

**▲ WARNING ▲**

Compressed air used for cleaning should not exceed 207 kPa [30 psi]. Use only with protective clothing, as well as goggles/shield, and gloves to avoid personal injury.

Use steam or solvent to clean the flywheel housing.

Dry with compressed air.



**Inspect for Reuse (016-006-007)**

Inspect the flywheel housing for cracks, especially in the bolt pattern area.

Inspect all surfaces for nicks, burrs, or cracks.

Use fine crocus cloth to remove small nicks and burrs.

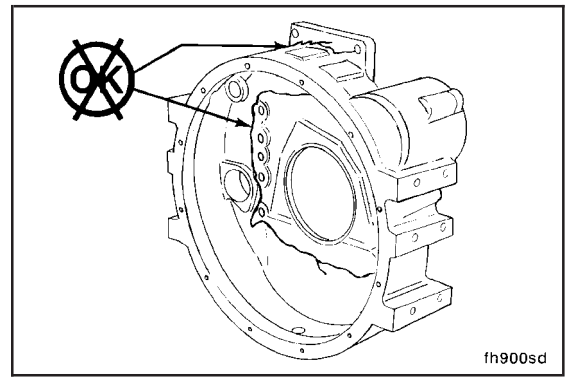

Inspect for damaged threads commonly caused by cross-threaded capscrews or installing an incorrect capscrew. Helicoils are available to repair damaged threads.

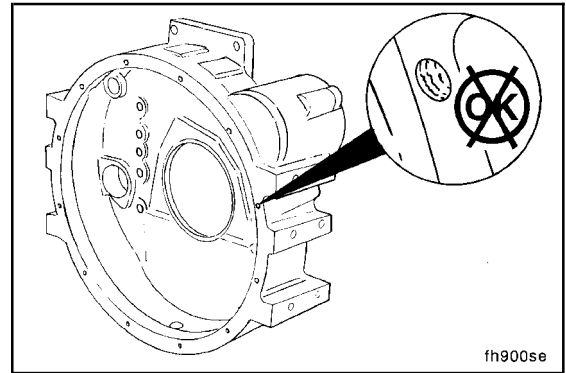

**Measure (016-006-010)**

**Bore Alignment**

**Dial Indicator Gauge, Part No. 3376050**

Attach the dial indicator gauge, Part No. 3376050, to the crankshaft. The dial indicator can be mounted by any method that holds the extension bar of the indicator rigid, so it does **not** sag. If the bar sags or the indicator slips, the readings obtained will **not** be accurate.

Position the indicator in the six-o'clock position, and zero the gauge.

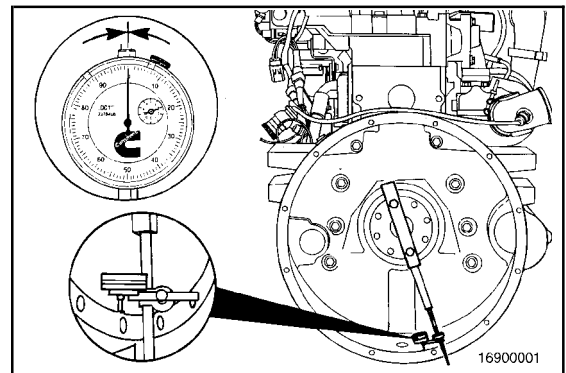

Slowly rotate the crankshaft. Record the readings obtained at the nine-o'clock, twelve-o'clock, and three-o'clock positions as [a], [b], and [c] in the concentricity work sheet. Recheck zero at the six-o'clock position.

The values for (a), (b), and (c) could be positive or negative. Refer to the accompanying figure to determine the correct sign when recording these values.

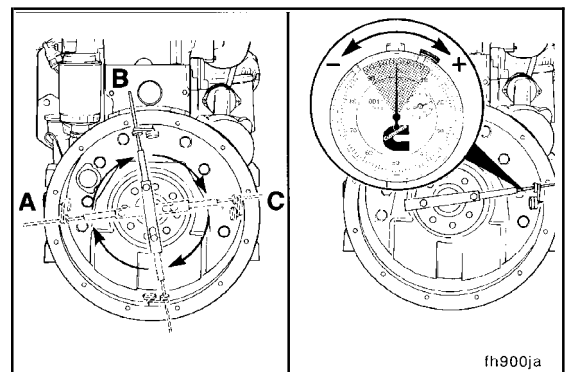

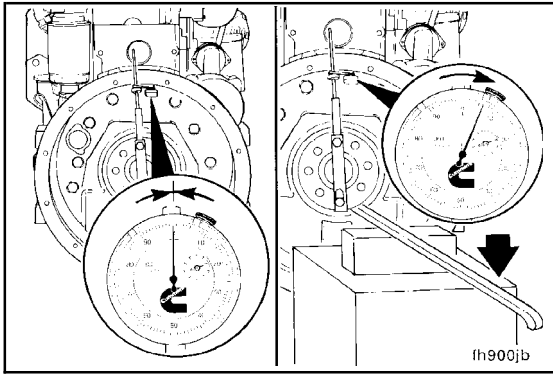

**CAUTION**

Do not force the crankshaft beyond the point where the bearing clearance has been removed. Do not pry against the flywheel housing. These actions could cause false bearing clearance readings.

Rotate the crankshaft until the dial indicator is at the twelve o'clock position and zero the gauge.

Using a pry bar, raise the rear of the crankshaft to its upper limit. Record the value as (d) in the concentricity work sheet. This is the vertical bearing clearance and will **always** be positive.

Concentricity Worksheet	
9 o'clock	a = 0.004
3 o'clock	c = -0.002
<b>Total Horizontal</b>	<b>a - c = .006</b>
<hr/>	
12 o'clock	b = .003
Bearing Clearance	d = .002
<b>Total Vertical</b>	<b>b + d = .005</b>

oi900vf

Using the concentricity work sheet, determine the values for the "total vertical" and "total horizontal" values.

The total horizontal is equal to the nine-o'clock reading (a), minus the three-o'clock reading (c).

The total vertical is equal to the twelve-o'clock reading (b), plus the bearing clearance (d).

Example:

- Six o'clock = ref = 0
- Nine o'clock = (a) = 0.004
- Twelve o'clock = (b) = 0.003
- Three o'clock = (c) = -0.002

Using the work sheet and the numbers from the example, the total horizontal value equals 0.006 and the total vertical value equals 0.005.

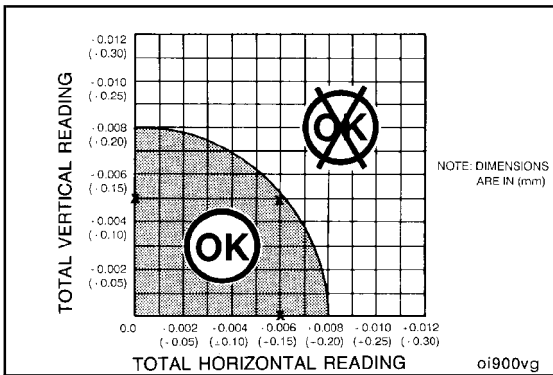

Mark the total horizontal value on the horizontal side of the chart and the total vertical on the vertical side of the chart.

Using a straightedge, find the intersection point of the total horizontal and total vertical values. The intersection point **must** fall within the shaded area for the flywheel housing concentricity to be within specification.

Using the total horizontal and total vertical values from the previous example, the intersection point falls within the shaded area. Therefore, the flywheel housing concentricity is within specification.

**B3.9 and B5.9 Series Engines  
Section 16 - Mounting Adaptations - Group 16**

If the intersection point falls outside the shaded area, the ring dowels **must** be removed and the housing repositioned.

**NOTE:** The ring dowels are **not** required to maintain concentricity of the housing; the clamping force of the capscrews holds the housing in place.

After the ring dowels are discarded, install the flywheel housing on the engine.

To position the housing, tighten the capscrews enough to hold the flywheel housing in place, but loose enough to allow small movement when struck lightly with a mallet.

Recheck the concentricity. When concentricity is within specification, tighten the capscrews to the specified torque value.

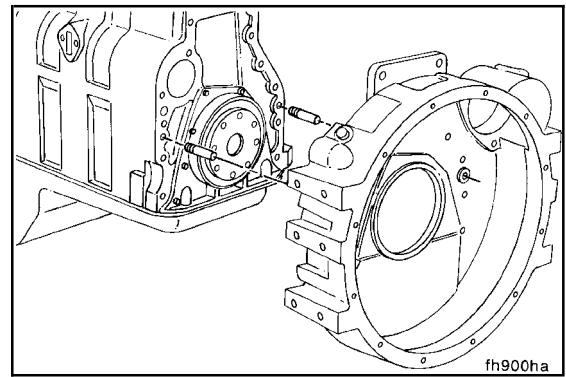

**▲ CAUTION ▲**

The dial indicator tip **must not** enter the capscrew holes, or the gauge will be damaged.

**Face Alignment**

**Dial Indicator Gauge, Part No. 3376050**

Install the dial indicator gauge, Part No. 3376050, as illustrated.

**NOTE:** The extension bar for the indicator **must** be rigid for an accurate reading. It **must not** sag. Position the indicator at the twelve-o'clock position. Adjust the dial until the needle points to zero.

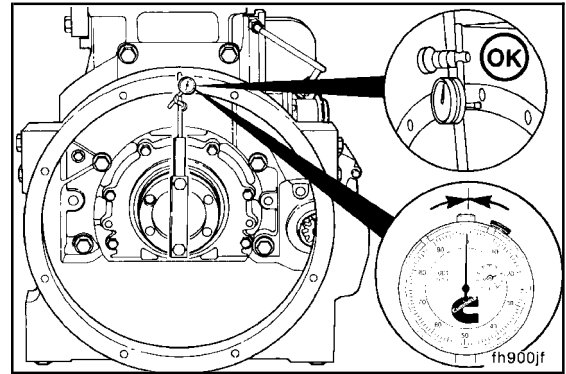

Slowly rotate the crankshaft. Record the readings at the three-o'clock, six-o'clock, and nine-o'clock positions.

**NOTE:** The crankshaft **must** be pushed toward the front of the engine to remove the crankshaft end clearance each time a position is measured.

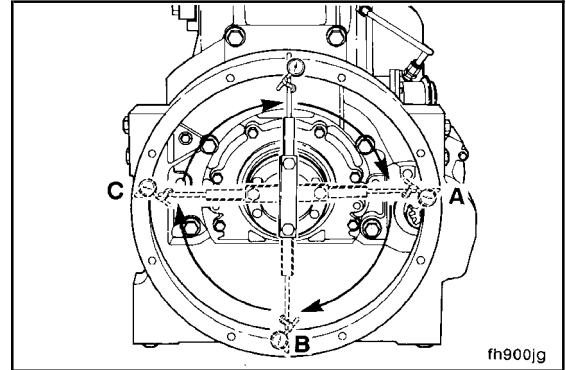

Continue to rotate the crankshaft until the indicator is at the twelve-o'clock position. Check the indicator to make sure the needle points to zero. If it does **not**, the readings will be incorrect.

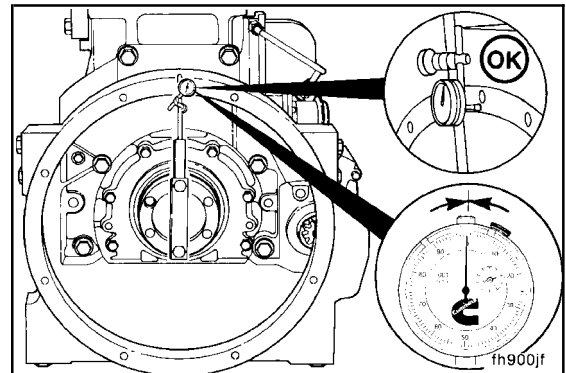

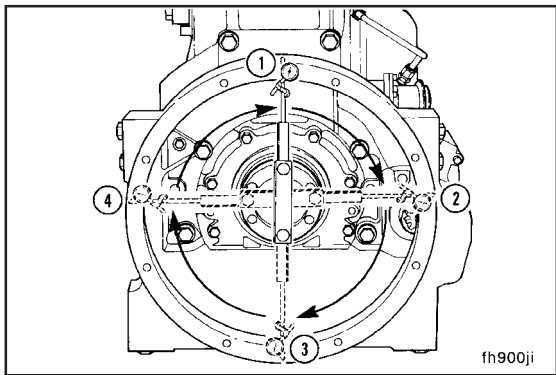

Determine the total indicator reading (TIR).

Example:	mm	in
12 o'clock	0.00	0.000
3 o'clock	+ 0.08	+ 0.003
6 o'clock	- 0.05	- 0.002
9 o'clock	+ 0.08	+ 0.003
Equals TIR	0.13	0.005

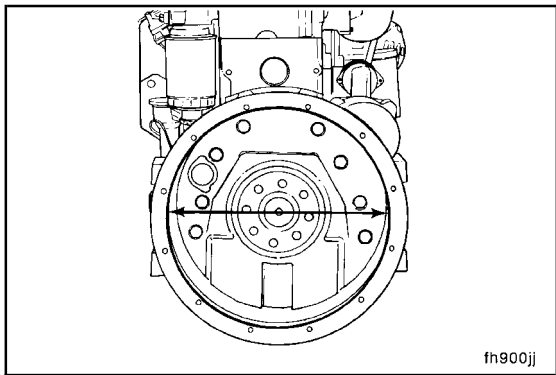

The maximum allowable total indicator reading (TIR) is determined by the diameter of the housing bore. If out of specifications, replace the housing.

SAE No.	Bore Diameter		TIR Max	
	mm	in	mm	in
2	447.68 to 447.80	17.625 to 17.30	0.20	0.008
3	409.58 to 409.70	16.125 to 16.130	0.20	0.008

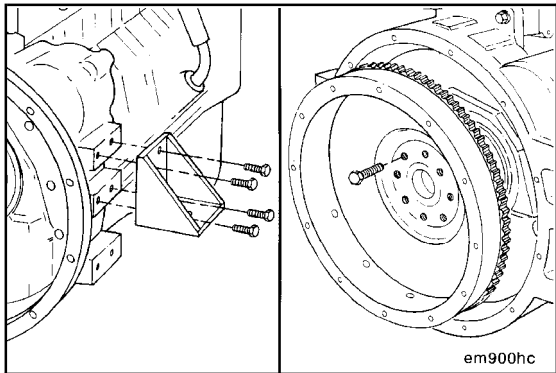

**Install (016-006-026)**

Install both rear engine mounts.



Install the flywheel and clutch (if equipped). Refer to the manufacturer's instructions.

Install the transmission and related components. Refer to the manufacturer's instructions.

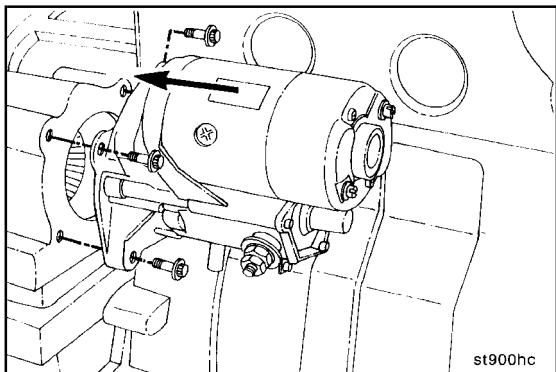

Install the starter motor. Refer to Procedure 013-020.



Connect the battery cables. Refer to Procedure 013-009.

**Dry Clutch Application**

Install rectangular seal, and lubricate with Lubriplate™ 105, or equivalent.

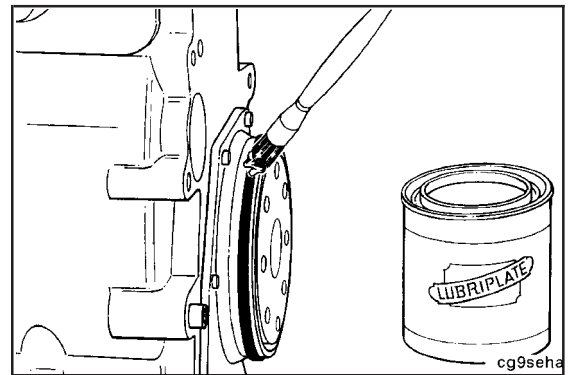

Inspect the rear face of the cylinder block and flywheel housing mounting surface for cleanliness and raised nicks or burrs.

Install the flywheel housing over the two ring dowels.

**NOTE:** Be sure the sealing ring is **not** damaged during installation.

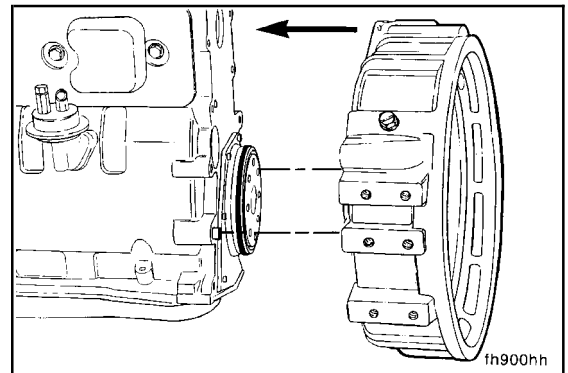

Tighten the flywheel housing capscrews in the sequence shown.

**Torque Value:** 77 N•m [57 ft-lb]

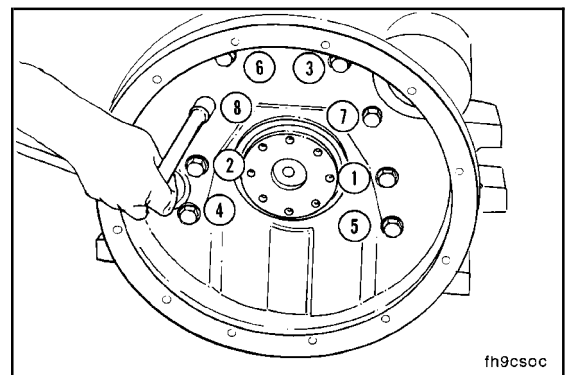

**Wet Clutch Application**

Perform all the steps in the procedure for dry clutch installation, in addition to the following:

- Coat the flywheel housing drain plug with pipe sealant, and install in the hole in the bottom of the flywheel housing.
- Tighten the plug.
- Refer to the pipe plug torque values in Section 17 for different plug sizes.

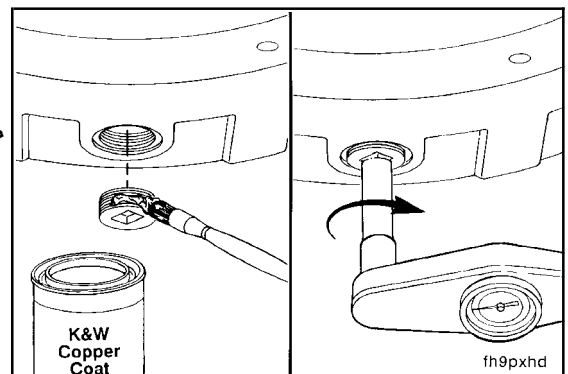

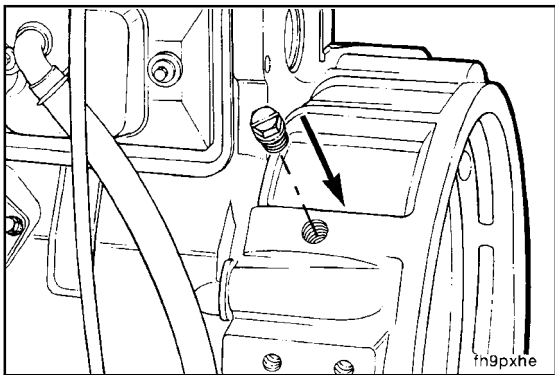

Install the plastic plug in the tachometer drive access hole.

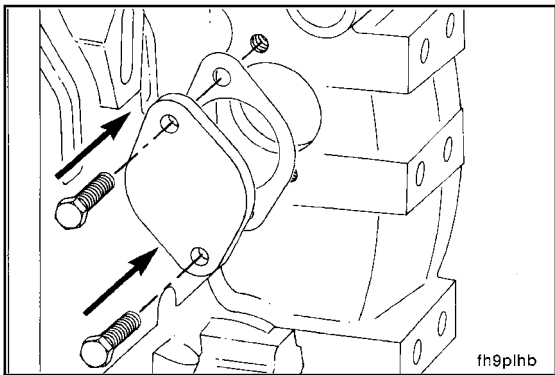

Install the access plate and new gasket.

Install the capscrews and tighten.

**Torque Value:** 24 N•m [18 ft-lb]

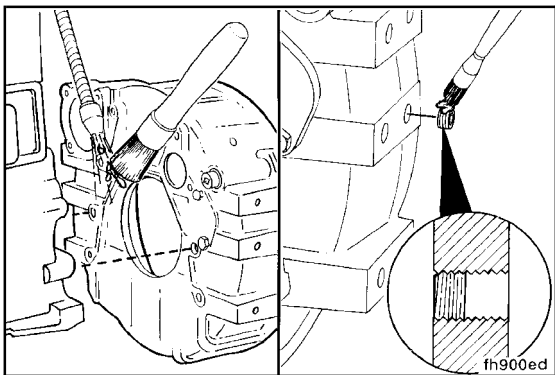

**▲ WARNING ▲**

When using a steam cleaner, wear safety glasses or a face shield, as well as protective clothing. Hot steam can cause serious personal injury.

**▲ WARNING ▲**

When using solvents, acids, or alkaline materials for cleaning, follow the manufacturer's recommendations for use. Wear goggles and protective clothing to avoid personal injury.

Thoroughly clean the flywheel housing and cylinder block mating surfaces. These surfaces **must** be clean of oil and debris.

**NOTE:** The capscrew holes on the mounting pads are drilled through. Coat set screws with Loctite 277 and install into holes.

**Set Screw Installation Depth (Flywheel Housing)**

mm		in
3.00	MAX	0.118

**B3.9 and B5.9 Series Engines  
Section 16 - Mounting Adaptations - Group 16**

**Flywheel Ring Gear (016-008)  
Page 16-21**

Apply a continuous bead of Three-Bond™ around all capscrew holes on the mounting surface of the flywheel housing.

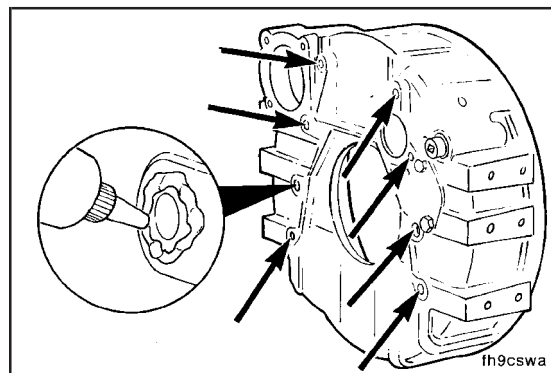

Coat the threads of the mounting capscrews with Loctite 277.

Install and tighten the capscrews.

**Torque Value:** 77 N•m [57 ft-lb]

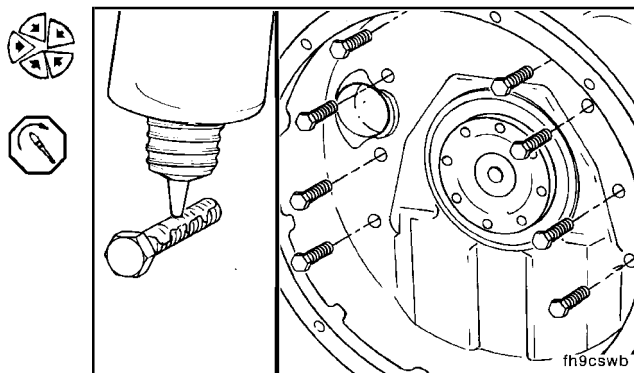

Install the plug into the barring gear hole.

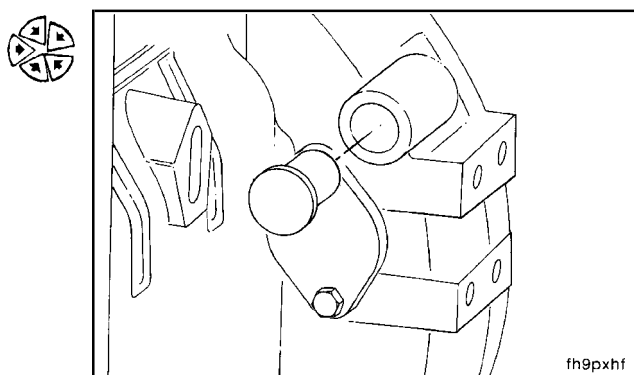

**Flywheel Ring Gear (016-008)  
Preparatory (016-008-000)**

Remove the transmission.

Refer to equipment manufacturer's instructions.

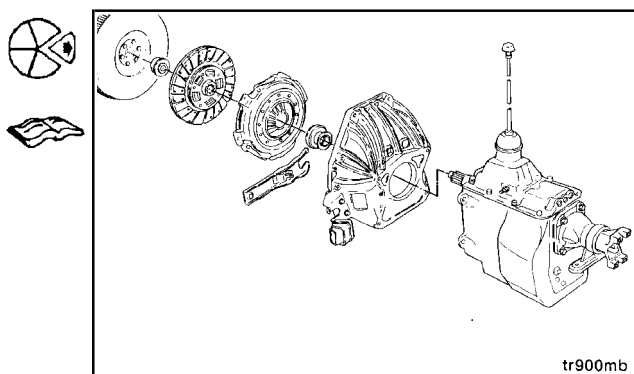

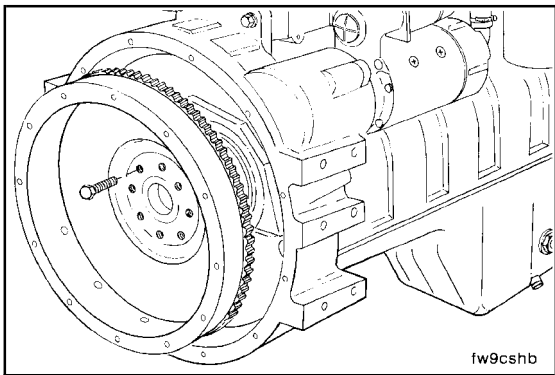

**Initial Check (016-008-001)**

Inspect the ring gear teeth for cracks and chips.

**NOTE:** If the ring gear teeth are damaged, the ring gear must be replaced.

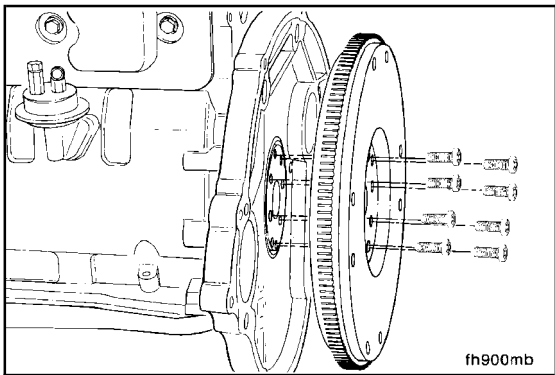

**Remove (016-008-002)**

**▲ WARNING ▲**

The component weighs 23 kg [50 lb] or more. To avoid personal injury, use a hoist or get assistance to lift the component.



Remove the flywheel. Refer to Procedure 016-005.

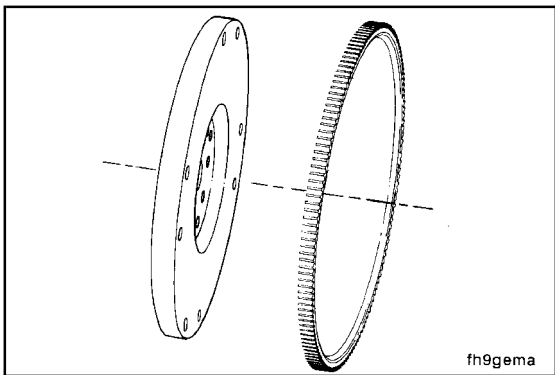

**▲ WARNING ▲**

To avoid severe eye damage, wear eye protection when you drive the gear from the flywheel. Do not use a steel drift pin.



**Brass Drift Pin**

Use the brass drift pin to drive the ring gear from the flywheel.

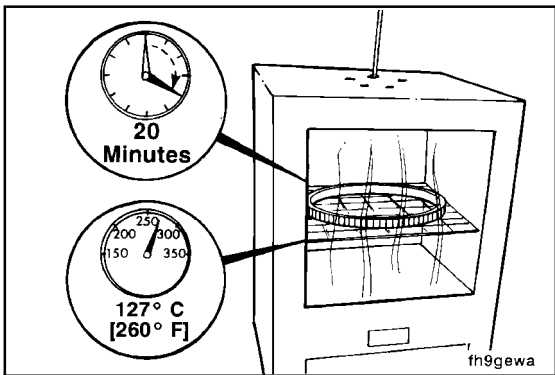

**Install (016-008-026)**

Heat the new ring gear for 20 minutes in an oven preheated to 127°C [260°F].



**▲ WARNING ▲**

To avoid severe burns, wear protective gloves when installing the heated gear.

**NOTE:** The ring gear **must** be installed so the bevel on the teeth is toward the crankshaft side of the flywheel.

Install the ring gear.

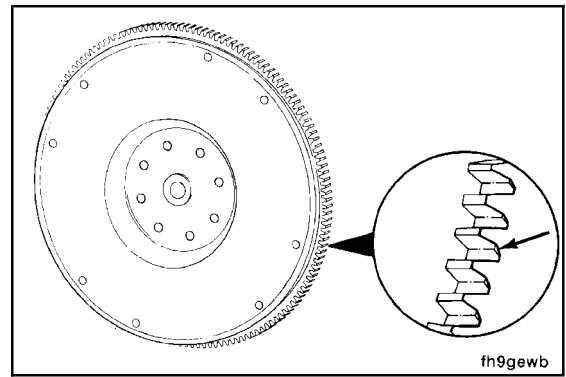

**Barring Tool, Part No. 3824591**

Use two capscrews and the barring tool, Part No. 3824591, in the front of the crankshaft to hold the crankshaft when the flywheel capscrews are being tightened.

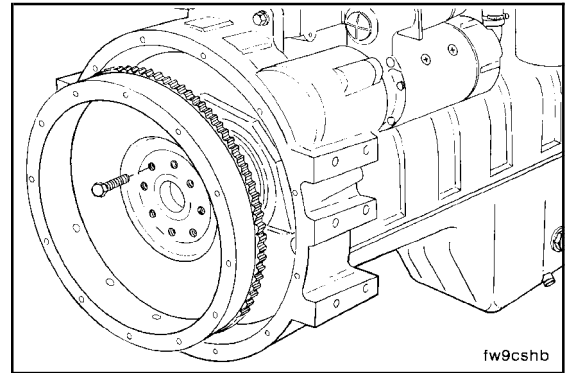

Tighten the capscrews in the sequence shown.

**Torque Value:** 137 N•m [101 ft-lb]

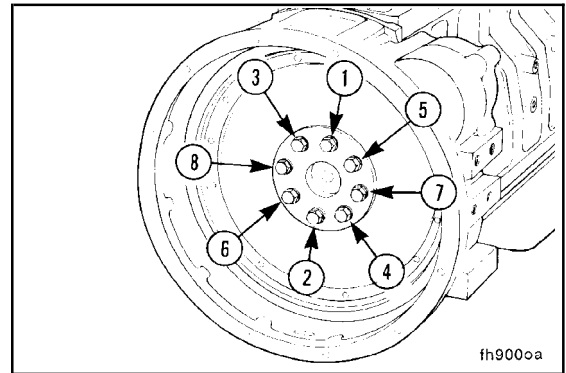

**Engine Mounts (016-010)**

**Inspect for Reuse (016-010-007)**

Inspect all rubber-cushioned mounts for cracks or damage.

Inspect all mounting brackets for cracks or damaged bolt holes.

**NOTE:** Damaged engine mounts and brackets can cause engine misalignment and driveline component damage, and result in vibration complaints.

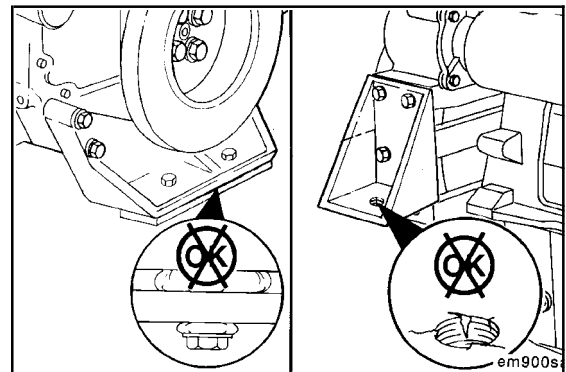



# Section 17 - Miscellaneous - Group 17



## Section Contents

	Page
<b>Cup Plug</b> .....	17-2
Clean .....	17-2
Inspect for Reuse .....	17-2
Install .....	17-3
Remove .....	17-2
<b>Expansion Plug</b> .....	17-5
Clean .....	17-5
Install .....	17-6
Remove .....	17-5
<b>Pipe Plug</b> .....	17-3
Clean .....	17-4
Inspect for Reuse .....	17-4
Install .....	17-4
Remove .....	17-3
<b>Service Tools</b> .....	17-1
Miscellaneous .....	17-1

**THIS PAGE LEFT INTENTIONALLY BLANK**

## Service Tools Miscellaneous

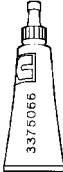
The following special tools are recommended to perform procedures in this section. The use of these tools is shown in the appropriate procedure. These tools can be purchased from your local Cummins Authorized Repair Location.

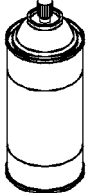
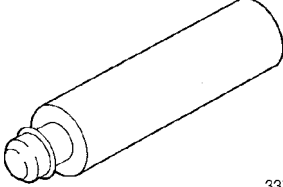
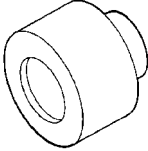
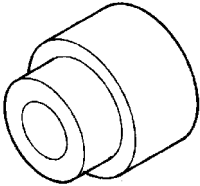
Tool No.	Tool Description	Tool Illustration
3375066	<b>Pipe Plug Sealant</b> Used when installing pipe plugs to stop leaks.	 <p style="text-align: right; font-size: small;">3375066</p>
3375068	<b>Cup Plug Sealant</b> Used when installing cup plugs to stop leaks.	 <p style="text-align: right; font-size: small;">3375068</p>
3375433	<b>Spray Cleaner</b> Used to clean cup plug opening.	 <p style="text-align: right; font-size: small;">3375433</p>
3376795	<b>Cup Plug Driving Tools (Universal Handle)</b> Required use with driver heads to install new cup plugs to their proper depth, plus avoiding damage to the cup plug and the surrounding area.	 <p style="text-align: right; font-size: small;">3376795</p>
3376816	<b>Cup Plug Driving Tools (Driver Head, 1-Inch nominal)</b> Used to install plug, Part No. 213395. Required to install new cup plugs to their proper depth, plus avoiding damage to the cup plug and the surrounding area.	 <p style="text-align: right; font-size: small;">3376816</p>
3376817	<b>Cup Plug Driving Tools (Driver Head, 1-1/4-Inch nominal)</b> Used to install plug, Part No. 216525. Required to install new cup plugs to their proper depth, plus avoiding damage to the cup plug and the surrounding area.	 <p style="text-align: right; font-size: small;">3376817</p>

**Cup Plug (017-002)**

**Remove (017-002-002)**



Do not allow metal shavings to fall in the engine when drilling a hole in the cup plug. Damage to engine components can occur.

Use a center punch to mark the cup plug for drilling.

Drill a 1/8-inch hole into the cup plug.

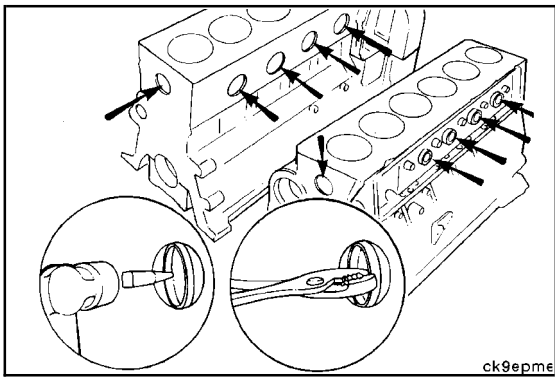

ck9epme

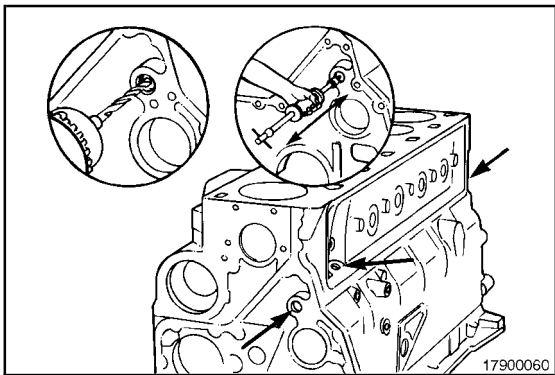

17900060



Use a dent puller to remove the plug.

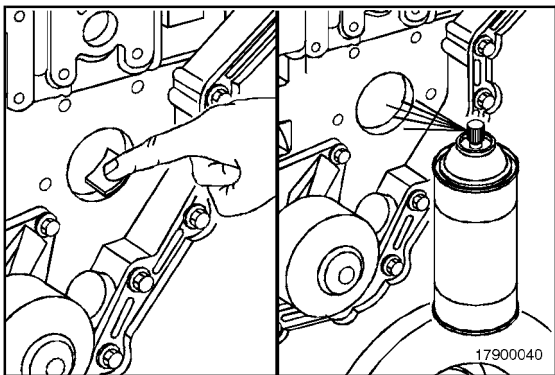

17900040



**Clean (017-002-006)**

**Spray Cleaner, Part No. 3375433**

Thoroughly clean the cup plug hole using Scotch-Brite™, or equivalent.

Use spray cleaner, Part No. 3375433, or equivalent, to clean the bore for the final time.

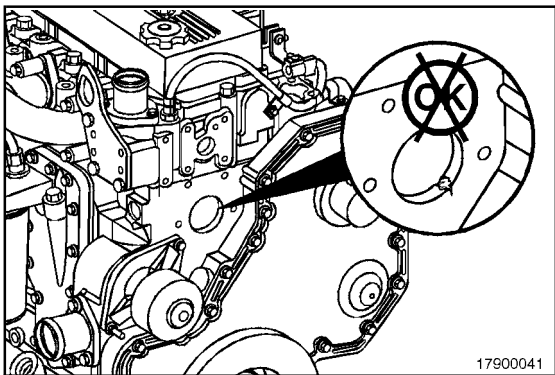

17900041



**Inspect for Reuse (017-002-007)**

Inspect the cup plug bores for damage.

**Install (017-002-026)**

**⚠ CAUTION ⚠**

Excessive sealant can run back into the engine and cause damage to other components. Allow the sealant to dry for a minimum of 2 hours before operating the engine. The plug can come out of the bore if the sealant is not dry.

**Cup Plug Sealant, Part No. 3375068**

Apply a 2-mm [1/16-in] bead of cup plug sealant, Part No. 3375068, or equivalent, to the outside circumference of the cup plug and the inside circumference of the cup plug bore.

**NOTE:** Do **not** install a used cup plug. Discard all plugs after removal.

Install the cup plug with the appropriate cup plug driver. Refer to the Service Products Catalog, Bulletin No. 3377710.

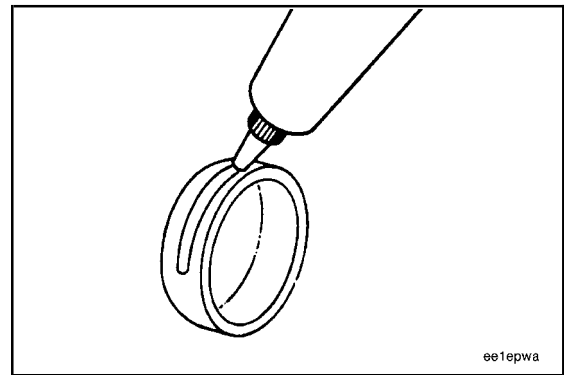

ee1epwa

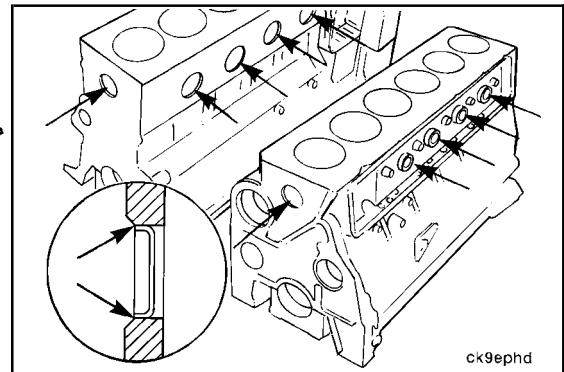

ck9ephd

**⚠ CAUTION ⚠**

Do not install the cup plug too deeply. If the cup plug is not installed straight and flat, it must be replaced with a new cup plug.

The cup plug **must** be installed with the edge of the cup plug 0.5 to 1.0 mm [0.020 to 0.040 in] deeper than the leading chamfer of the bore.

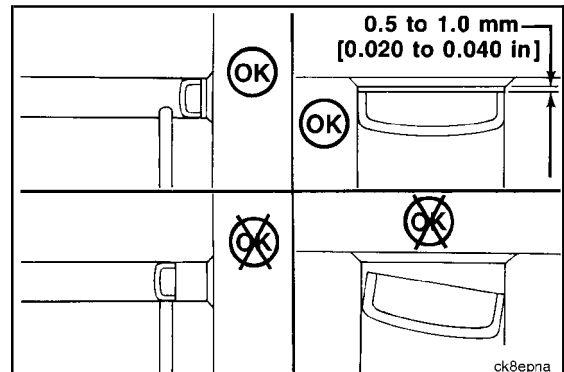

ck8epna

**Pipe Plug (017-007)**

**Remove (017-007-002)**

Remove the pipe plug.

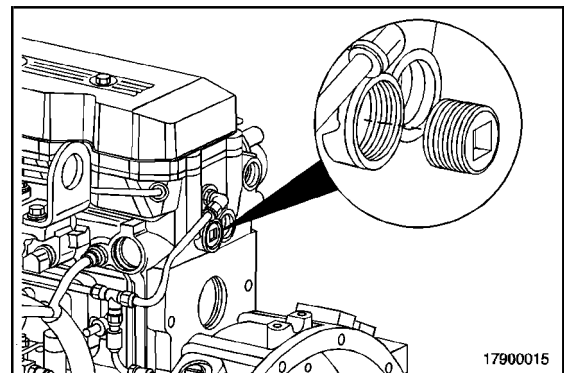

17900015

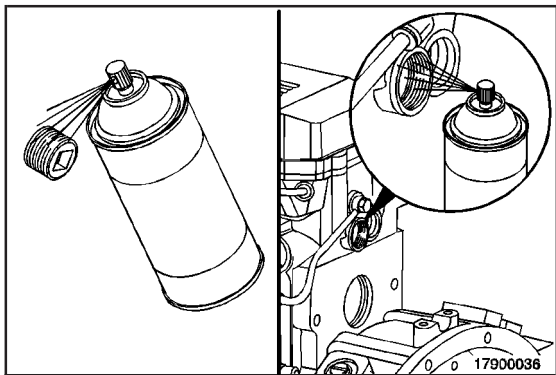

**Clean (017-007-006)**

**Spray Cleaner, Part No. 3375433**



Use spray cleaner, Part No. 3375433, or equivalent, to clean the threads of the pipe plugs and threaded bores.

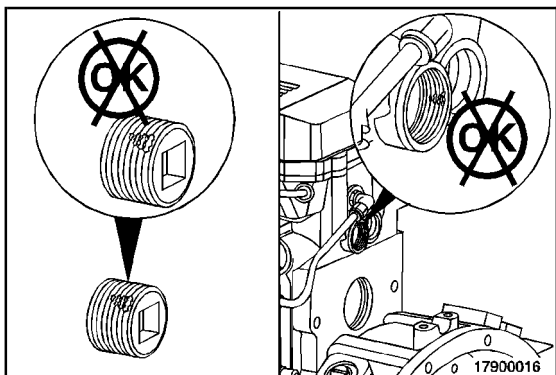

**Inspect for Reuse (017-007-007)**

Inspect the threads of the pipe plugs for mutilation or damage.

Inspect the threaded bores for damage.

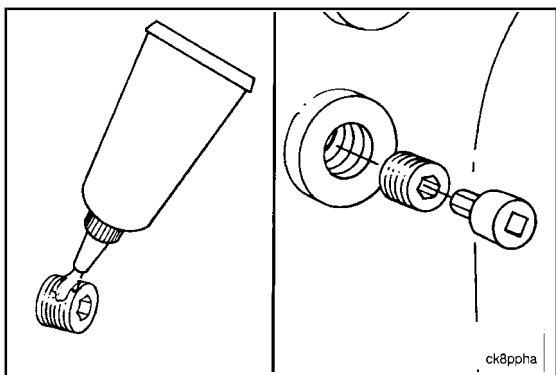

**Install (017-007-026)**

**Cup Plug Sealant, Part No. 3375068**



Apply a film of pipe plug sealant, Part No. 3375066, or equivalent, to the threads.

Install the pipe plugs.

Pipe Plug Torque Values						
Size		Torque		Torque		
Thread	Actual Thread O.D.	In Aluminum Components	In Cast Iron or Steel Components			
in.	mm	[in]	N•m	[ft-lbs]	N•m	[ft-lbs]
1/16	8.1	[0.32]	5	[45 in-lb]	15	[10]
1/8	10.4	[0.41]	15	[10]	20	[15]
1/4	13.7	[0.54]	20	[15]	25	[20]
3/8	17.3	[0.68]	25	[20]	35	[25]
1/2	21.6	[0.85]	35	[25]	55	[40]
3/4	26.7	[1.05]	45	[35]	75	[55]
1	33.5	[1.32]	60	[45]	95	[70]
1 1/4	42.2	[1.66]	75	[55]	115	[85]
1 1/2	48.3	[1.90]	85	[65]	135	[100]



Tighten the pipe plugs. Refer to the adjoining chart for the appropriate torque values.





### Expansion Plug (017-015)

#### Remove (017-015-002)

**NOTE:** Care should be taken **not** to drive the expansion plug out and into the water jacket, especially the plug on the end of the cylinder block.

Remove the expansion plugs from the coolant passages as shown.

**Service Tip:** If it becomes apparent the expansion plug is **not** going to pivot in the bore, use a center punch to catch the edge of the expansion plug and pry against the cylinder block to pivot the expansion plug out.

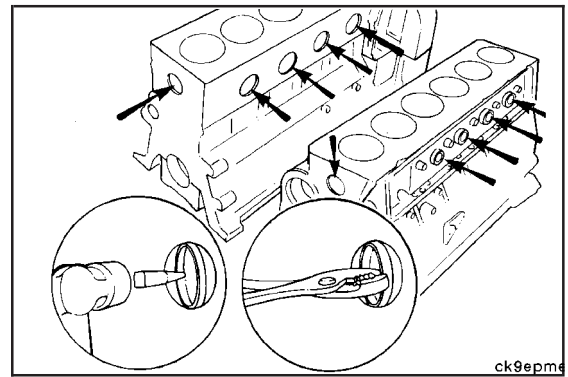

ck9epm

Remove the expansion plugs from the oil passages.

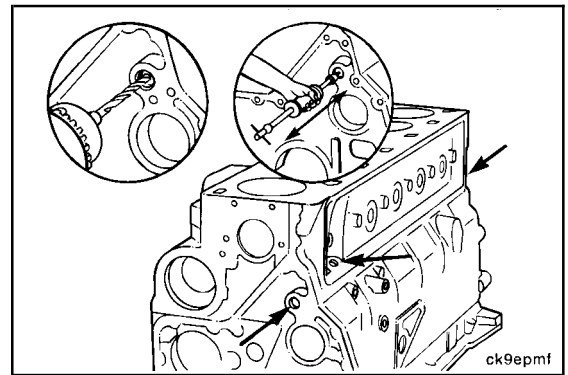

ck9epmf

#### Clean (017-015-006)

##### Spray Cleaner, Part No. 3375433

Thoroughly clean the expansion plug hole using Scotch-Brite™, or equivalent. Use spray cleaner 3375433, or equivalent, to finish cleaning the bore.

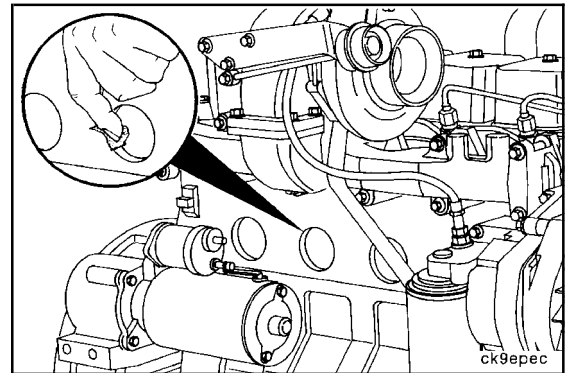

ck9epec

Inspect the cup plug bores for damage.

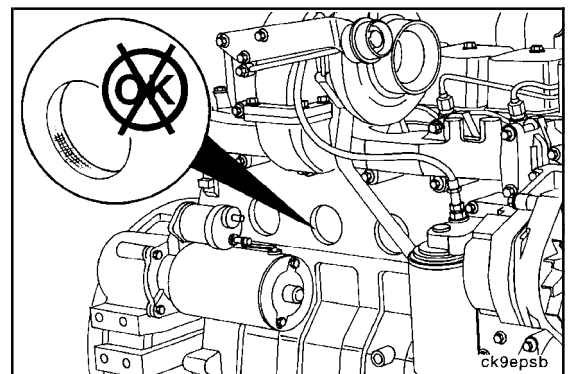

ck9epsb

**Install (017-015-026)**

Apply a 2 mm [1/16 in] of Loctite 277, or equivalent, to the coolant passage expansion plugs. Apply Loctite 277 to the inside diameter of the expansion plug installation bore.

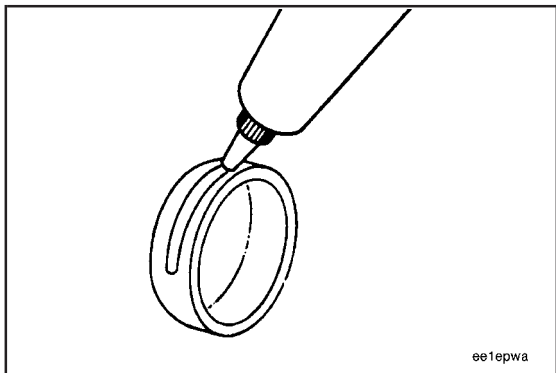

ee1epwa

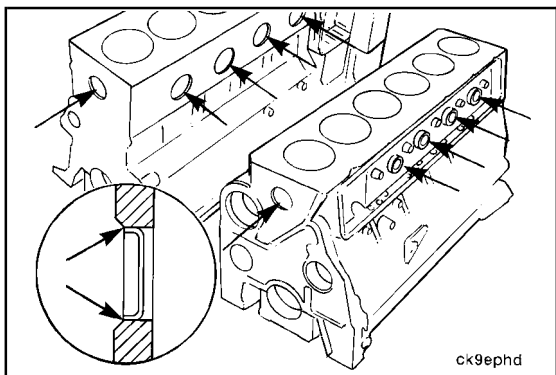

ck9ephd



Drive the expansion plug in until the outer edge is flush with the countersink in the block.

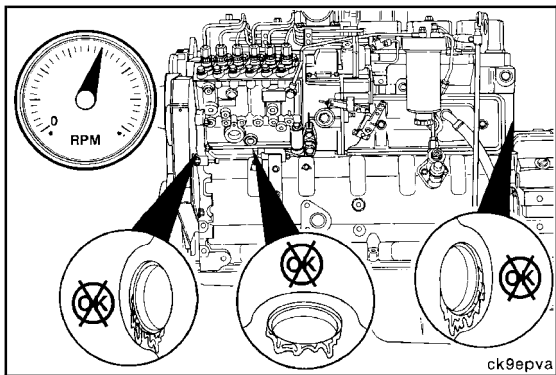

ck9epva



Fill the engine with clean lubricating engine oil.  
Operate the engine, and check for leaks.  
Stop the engine, and check the lubricating oil level with the dipstick.

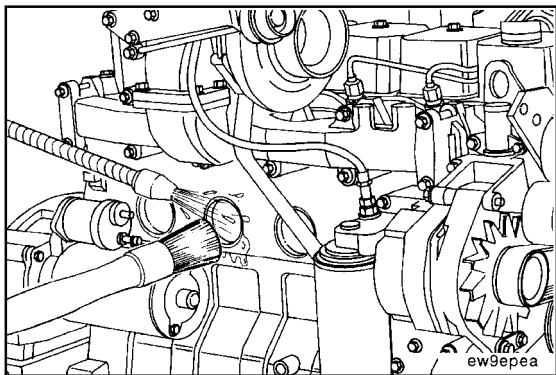

ew9epea



Clean the area near the expansion plug of all debris.

# Section V - Specifications

## Section Contents

	Page
<b>Air Intake System - Specifications</b> .....	V-30
Air Intake Restriction .....	V-30
Charge-Air Cooler (CAC) .....	V-30
Turbocharger .....	V-30
Turbocharger Axial Clearance .....	V-30
Turbocharger Radial Bearing Clearance .....	V-30
Turbocharger Turbine Seal Leaks .....	V-31
Turbocharger Wastegate Actuator .....	V-31
<b>Air Intake System - Torque Values</b> .....	V-32
Aftercooler .....	V-32
Air Crossover .....	V-32
Air Intake Manifold .....	V-32
Air Intake Manifold Heater .....	V-33
Air Leaks, Air Intake and Exhaust Systems .....	V-32
Turbocharger .....	V-32
Turbocharger Oil Drain Line .....	V-33
Turbocharger Oil Supply Line .....	V-33
Turbocharger Radial Bearing Clearance .....	V-33
Turbocharger Turbine Seal Leaks .....	V-33
Turbocharger Wastegate Actuator .....	V-33
<b>Cam Followers/Tappets - Specifications</b> .....	V-13
Tappet .....	V-13
<b>Cam Followers/Tappets - Torque Values</b> .....	V-14
Push Rods or Tubes .....	V-14
<b>Capscrew Markings and Torque Values</b> .....	V-70
Capscrew Markings and Torque Values - Metric .....	V-71
Capscrew Markings and Torque Values - U.S. Customary .....	V-72
<b>Compressed Air System - Specifications</b> .....	V-36
Air Compressor Cylinder Head (Holset® QE Models) .....	V-37
Air Compressor Cylinder Head (Holset® SS191 Model) .....	V-36
<b>Compressed Air System - Torque Values</b> .....	V-38
Air Compressor Coolant Lines .....	V-38
Air Compressor Cylinder Head (Holset® QE Models) .....	V-39
Air Compressor Cylinder Head (Holset® SS191 Model) .....	V-38
Air Compressor Unloader and Valve Assembly .....	V-38
<b>Cooling System - Specifications</b> .....	V-27
Coolant Temperature Sensor, OEM .....	V-27
Coolant Thermostat .....	V-27
Radiator Shutter Assembly .....	V-27
Water Pump .....	V-27
<b>Cooling System - Torque Values</b> .....	V-28
Coolant Heater .....	V-28
Coolant Temperature Sensor, OEM .....	V-29
Coolant Thermostat .....	V-28
Fan Clutch, Electric .....	V-28
Fan, Cooling .....	V-28
Fan Spacer and Pulley .....	V-28
Sea Water Heat Exchanger .....	V-28
<b>Cylinder Block - Specifications</b> .....	V-1
Bearings, Connecting Rod .....	V-1
Bearings, Main .....	V-1
Camshaft .....	V-1
Camshaft Bushings .....	V-2
Connecting Rod .....	V-2
Crankshaft .....	V-3
Piston .....	V-4
Piston and Connecting Rod Assembly .....	V-5
Piston Rings .....	V-4

	Page
Vibration Damper .....	V-5
<b>Cylinder Block - Torque Values</b> .....	V-6
Bearings, Connecting Rod .....	V-6
Bearings, Main .....	V-6
Camshaft .....	V-6
Camshaft Gear (Camshaft Removed) .....	V-6
Connecting Rod .....	V-6
Crankshaft .....	V-6
Crankshaft Seal, Front .....	V-7
Crankshaft Seal, Rear .....	V-7
Gear Cover, Front .....	V-7
Gear Housing, Front .....	V-7
Piston and Connecting Rod Assembly .....	V-8
Timing Pin Housing .....	V-7
Vibration Damper .....	V-7
<b>Cylinder Head - Specifications</b> .....	V-9
Valve, Cylinder Head .....	V-9
<b>Cylinder Head - Torque Values</b> .....	V-10
Cylinder Head .....	V-10
Valve, Cylinder Head .....	V-10
<b>Drive Belt Tension</b> .....	V-68
<b>Electrical Equipment - Torque Values</b> .....	V-40
Alternator Bracket .....	V-40
Alternator Pulley .....	V-40
Starting Motor .....	V-40
<b>Engine Component Torque Values</b> .....	V-69
<b>Engine Testing - Specifications</b> .....	V-41
Engine Testing (Chassis Dynamometer) .....	V-41
Engine Testing (Engine Dynamometer) .....	V-41
Engine Testing (In Chassis) .....	V-42
<b>Exhaust System - Specifications</b> .....	V-34
Exhaust Restriction .....	V-34
<b>Exhaust System - Torque Values</b> .....	V-35
Exhaust Manifold, Dry .....	V-35
<b>Fraction, Decimal, Millimeter Conversions</b> .....	V-74
<b>Fuel System - Specifications</b> .....	V-15
Fuel Flow .....	V-15
<b>Fuel System - Torque Values</b> .....	V-16
Cold Start Timing Advance System (KSB) Pump Mounted .....	V-20
Cold Start Timing Advance System (KSB) Remote .....	V-20
Cold Start Timing Advance System (KSB) Temperature Switch .....	V-20
Engine Fuel Heater, Electric .....	V-16
Fuel Injection Pump, In-Line, Spill Port Timing .....	V-16
Fuel Injection Pump, Rotary .....	V-17
Fuel Injection Pumps, In-Line .....	V-16
Fuel Lift Pump .....	V-19
Fuel Pump Idle Speed .....	V-18
Fuel Pump Support Bracket .....	V-18
Fuel Pump Timing .....	V-18
Fuel Shutoff Valve .....	V-19
<b>Injectors and Fuel Lines - Specifications</b> .....	V-21
Fuel Drain Line Restriction .....	V-21
Fuel Inlet Restriction .....	V-21
<b>Injectors and Fuel Lines - Torque Values</b> .....	V-22
AFC Air Tube .....	V-22
Fuel Drain Line Restriction .....	V-22
Fuel Manifold (Drain) .....	V-22
Fuel Supply Lines .....	V-23
Injector .....	V-23

	<b>Page</b>
Injector Supply Lines (High Pressure) .....	V-23
<b>Lubricating Oil System - Specifications</b> .....	V-24
Lubricating Oil Cooler .....	V-24
Lubricating Oil Pump .....	V-24
<b>Lubricating Oil System - Torque Values</b> .....	V-25
Engine Oil Heater .....	V-25
Lubricating Oil Cooler .....	V-25
Lubricating Oil Pan .....	V-25
Lubricating Oil Pressure Regulator (Main Rifle) .....	V-25
Lubricating Oil Pressure Sensor, OEM .....	V-26
Lubricating Oil Suction Tube (Block-Mounted) .....	V-25
<b>Mounting Adaptations - Specifications</b> .....	V-43
<b>Mounting Adaptations - Torque Values</b> .....	V-44
Engine Support Bracket, Front .....	V-44
Flywheel .....	V-44
Flywheel Housing .....	V-44
Flywheel Ring Gear .....	V-44
<b>Newton-Meter to Foot-Pound Conversion Chart</b> .....	V-73
<b>Pipe Plug Torque Values</b> .....	V-75
<b>Rocker Levers - Specifications</b> .....	V-11
Overhead Set .....	V-11
Rocker Lever .....	V-11
<b>Rocker Levers - Torque Values</b> .....	V-12
Rocker Lever Cover .....	V-12
<b>Specifications</b> .....	V-45
Air Intake System .....	V-53
Batteries (Specific Gravity) .....	V-66
Compressed Air System .....	V-62
Cooling System .....	V-51
Electrical System .....	V-64
Engine Testing .....	V-66
Exhaust System .....	V-60
Fuel System .....	V-47
General Specifications .....	V-45
Lubricating Oil System .....	V-49
<b>Tap-Drill Chart - U.S. Customary and Metric</b> .....	V-76
<b>Weights and Measures - Conversion Factors</b> .....	V-77

**THIS PAGE LEFT INTENTIONALLY BLANK**

Component or Assembly (Procedure)	Ref.No./Steps	Metric	U.S.
-----------------------------------	---------------	--------	------

**Cylinder Block - Specifications**  
**Bearings, Connecting Rod (001-005)**

**Connecting Rod Bearing Dimensions**

Standard	1.955 mm	MIN	0.0770 in
	1.968 mm	MAX	0.0775 in
0.25 mm Oversize	2.080 mm	MIN	0.0819 in
	2.093 mm	MAX	0.0824 in
0.50 mm Oversize	2.205 mm	MIN	0.0868 in
	2.218 mm	MAX	0.0873 in
0.75 mm Oversize	2.330 mm	MIN	0.0917 in
	2.343 mm	MAX	0.0922 in
1.00 mm Oversize	2.455 mm	MIN	0.0967 in
	2.468 mm	MAX	0.0972 in

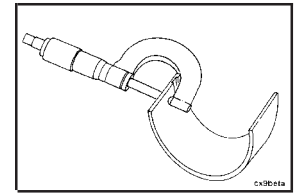

**Connecting Rod Side Clearance Limits**

	0.10 mm	MIN	0.004 in
	0.33 mm	MAX	0.013 in

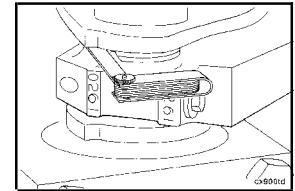

**Bearings, Main (001-006)**

**Main Bearing Bore Diameter (Maximum)**

	83.106 mm	MAX	3.272 in
--	-----------	-----	----------

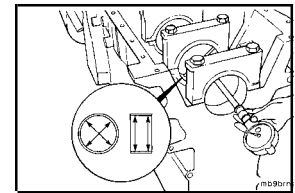

**Dimension (A) End Play Limits**

	0.127 mm	MIN	0.005 in
	0.431 mm	MAX	0.017 in

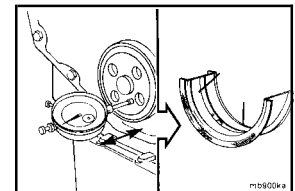

**Dim. (A) End Play Limits**

	0.102 mm	MIN	0.004 in
	0.432 mm	MAX	0.017 in

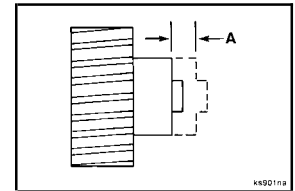

**Camshaft (001-008)**

**Fuel Transfer Pump Lobe Diameter**

	35.50 mm	MIN	1.398 in
	36.26 mm	MAX	1.428 in

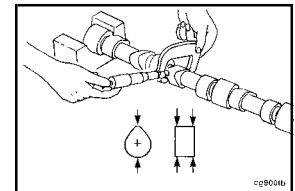

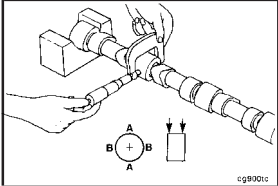
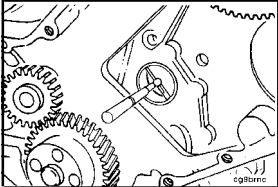
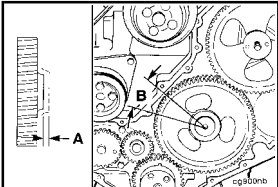
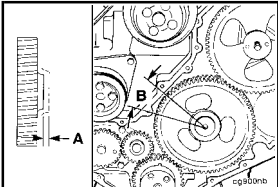
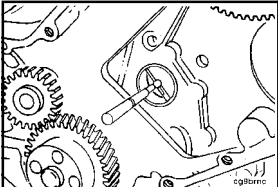
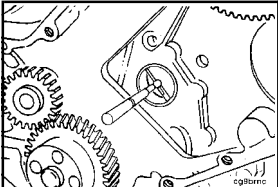
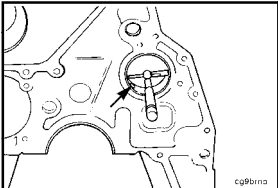
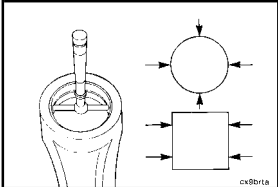
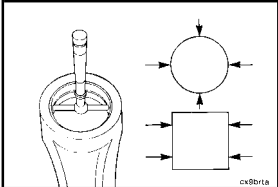
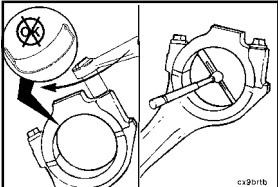
	Component or Assembly (Procedure)	Ref.No./Steps	Metric		U.S.
	<b>Journal Diameter</b>		53.962 mm 54.013 mm	MIN MAX	2.1245 in 2.1265 in
	<b>Camshaft Bore Inside Diameter</b> No. 1 Bushing All Except No. 1		54.146 mm 54.164 mm	MAX MAX	2.1317 in 2.1324 in
	<b>Camshaft End Play (A)</b>		0.12 mm 0.47 mm	MIN MAX	0.005 in 0.018 in
	<b>Camshaft Gear Backlash Limits (B)</b>		0.330 mm 0.76 mm	MIN MAX	0.013 in 0.030 in
	<b>Camshaft Bushings (001-010)</b>		59.248 mm 57.248 mm 54.147 mm 54.164 mm	MAX MAX MAX MAX	2.3326 in 2.2539 in 2.1318 in 2.1324 in
	<b>Camshaft Bore Diameter (Maximum)</b> Storm Block - No. 1 only (without bushing installed) Prestorm Block - No. 1 only (without bushing installed) No. 1 only (with bushing) No. 2 through No. 7		59.248 mm 57.248 mm 54.147 mm 54.164 mm	MAX MAX MAX MAX	2.3326 in 2.2539 in 2.1318 in 2.1324 in
	<b>Camshaft Bore (Bushing Installed)</b>		54.107 mm 54.146 mm	MIN MAX	2.1302 in 2.1317 in
	<b>Connecting Rod (001-014)</b>		40.019 mm 40.042 mm	MIN MAX	1.5755 in 1.5765 in
	<b>Connecting Rod Piston Pin Bushing Diameter</b>		40.019 mm 40.042 mm	MIN MAX	1.5755 in 1.5765 in
	<b>Connecting Rod Crank Bore Diameter (Bearings Removed)</b>		72.987 mm 73.013 mm	MIN MAX	2.8735 in 2.8745 in

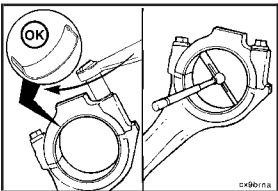
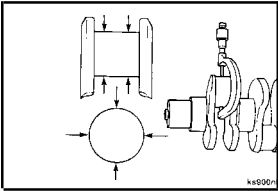
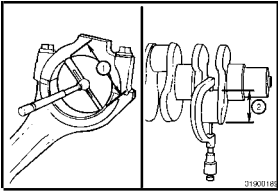
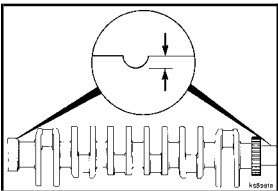
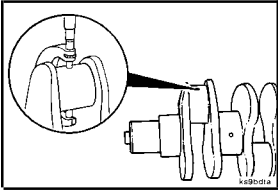
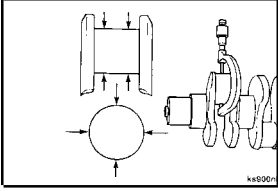
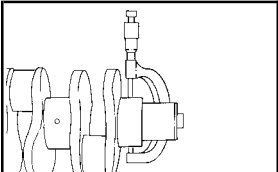
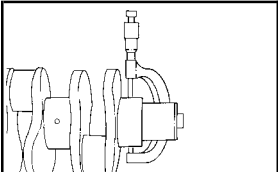

Component or Assembly (Procedure)	Ref.No./Steps	Metric	U.S.		
<b>Connecting Rod Bore Diameter (Bearings Installed)</b>					
Standard		69.051 mm	MIN	2.7185 in	
		69.103 mm	MAX	2.7205 in	
0.25 mm Oversize		68.801 mm	MIN	2.7087 in	
		68.853 mm	MAX	2.7107 in	
0.50 mm Oversize		68.551 mm	MIN	2.6989 in	
		68.603 mm	MAX	2.7009 in	
0.75 mm Oversize		68.301 mm	MIN	2.6890 in	
		68.353 mm	MAX	2.6911 in	
1.00 mm Oversize		68.051 mm	MIN	2.6792 in	
		68.103 mm	MAX	2.6812 in	
<b>Crankshaft Rod Journal Diameter</b>					
Standard		68.962 mm	MIN	2.7150 in	
		69.012 mm	MAX	2.7170 in	
0.25 mm Undersize		68.712 mm	MIN	2.7052 in	
		68.762 mm	MAX	2.7072 in	
0.50 mm Undersize		68.462 mm	MIN	2.6953 in	
		68.512 mm	MAX	2.6973 in	
0.75 mm Undersize		68.212 mm	MIN	2.6855 in	
		68.262 mm	MAX	2.6875 in	
1.0 mm Undersize		67.952 mm	MIN	2.6753 in	
		69.012 mm	MAX	2.7170 in	
<b>Bearing Clearance</b>					
		0.038 mm	MIN	0.0015 in	
		0.116 mm	MAX	0.0046 in	
<b>Crankshaft (001-016)</b>					
<b>Crankshaft Front and Rear Oil Seal Wear Groove</b>					
		0.25 mm	MAX	0.010 in	
<b>Connecting Rod Bearing Journal Diameter</b>					
Standard		68.987 mm	MIN	2.716 in	
Machined 0.25 mm		68.737 mm	MIN	2.706 in	
Machined 0.50 mm		68.487 mm	MIN	2.696 in	
Machined 0.75 mm		68.237 mm	MIN	2.687 in	
Machined 1.00 mm		67.987 mm	MIN	2.677 in	
<b>Connecting Rod Bearing Journal</b>					
Out-of-Roundness		0.050 mm	MAX	0.0020 in	
Taper		0.013 mm	MAX	0.0005 in	
<b>Main Bearing Journal Diameter</b>					
Standard		82.987 mm	MIN	3.267 in	
Machined 0.25 mm		82.737 mm	MIN	3.257 in	
Machined 0.50 mm		82.487 mm	MIN	3.248 in	
<b>Crankshaft Main Bearing Journal</b>					
Out-of-Roundness		0.05 mm	MAX	0.0020 in	
Taper		0.01 mm	MAX	0.0004 in	

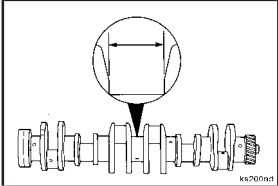
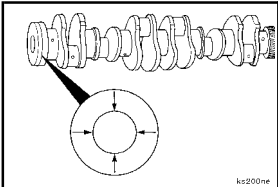
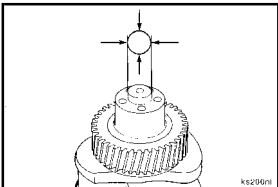
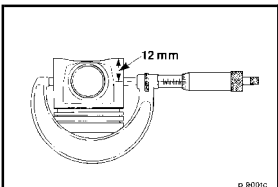
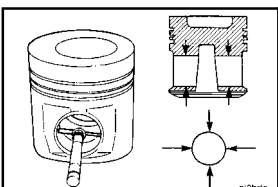
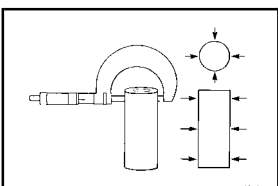
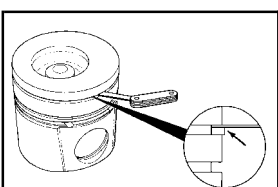
Component or Assembly (Procedure)	Ref.No./Steps	Metric	U.S.
 <p>Diagram showing the measurement of the crankshaft thrust face width. A callout circle highlights the thrust face, and a dimension line indicates the width.</p>	<b>Crankshaft Thrust Face Width (Standard)</b>	42.98 mm 43.08 mm	MIN 1.692 in MAX 1.696 in
 <p>Diagram showing the measurement of the crankshaft rear oil seal flange outside diameter. A callout circle highlights the flange, and a dimension line indicates the diameter.</p>	<b>Crankshaft Rear Oil Seal Flange Outside Diameter</b>	129.98 mm 130.03 mm	MIN 5.117 in MAX 5.119 in
 <p>Diagram showing the measurement of the crankshaft damper pilot outside diameter. A callout circle highlights the damper pilot, and a dimension line indicates the diameter.</p>	<b>Crankshaft Damper Pilot Outside Diameter</b>	18.924 mm 19.00 mm	MIN 0.745 in MAX 0.748 in
 <p>Diagram showing the measurement of the piston skirt diameter. A callout circle highlights the skirt, and a dimension line indicates the diameter. A note indicates a 12 mm measurement point.</p>	<b>Piston (001-043)</b> <b>Piston Skirt Diameter</b>	101.823 mm 101.887 mm	MIN 4.0088 in MAX 4.0107 in
 <p>Diagram showing the measurement of the piston pin bore diameter. A callout circle highlights the bore, and a dimension line indicates the diameter.</p>	<b>Piston Pin Bore Diameter</b>	40.006 mm 40.025 mm	MIN 1.5750 in MAX 1.5758 in
 <p>Diagram showing the measurement of the pin diameter. A callout circle highlights the pin, and a dimension line indicates the diameter.</p>	<b>Pin Diameter</b>	39.990 mm 40.003 mm	MIN 1.5744 in MAX 1.5749 in
 <p>Diagram showing the measurement of the piston rings. A callout circle highlights the ring, and a dimension line indicates the clearance. A note indicates the oil control measurement.</p>	<b>Piston Rings (001-047)</b>	Ring Clearance Top 0.075 mm Intermediate 0.085 mm Oil Control 0.040 mm	MIN 0.003 in MAX 0.006 in MIN 0.003 in MAX 0.006 in MIN 0.0016 in MAX 0.0051 in

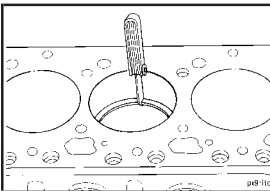
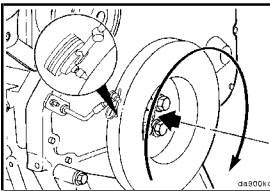
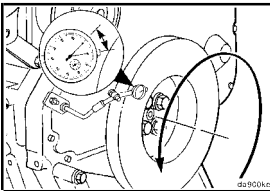
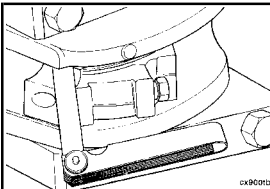
Component or Assembly (Procedure)	Ref.No./Steps	Metric	U.S.	
<b>Ring Gap</b>				
Top		0.40 mm 0.70 mm	MIN MAX	0.0157 in 0.0275 in
Intermediate		0.25 mm 0.55 mm	MIN MAX	0.0100 in 0.0216 in
Oil Control		0.25 mm 0.55 mm	MIN MAX	0.0100 in 0.0216 in
				
<b>Vibration Damper (001-052)</b>				
<b>Vibration Damper Eccentricity</b> per 25.4 mm [1.0 in] of Diameter		0.10 mm	MAX	0.004 in
				
<b>Vibration Damper Wobble</b> per 25.4 mm [1.0 in] of Radius		0.18 mm	MAX	0.007 in
				
<b>Piston and Connecting Rod Assembly (001-054)</b>				
<b>Side Clearance Limits</b>		0.10 mm 0.33 mm	MIN MAX	0.004 in 0.013 in
				

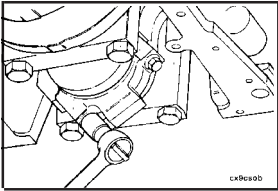
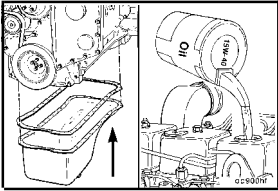
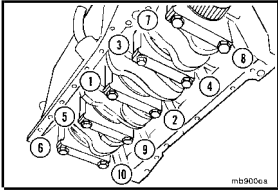
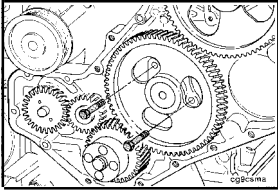
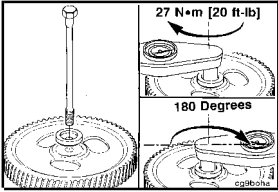
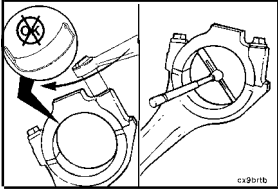
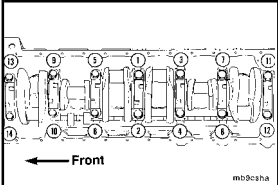
Component or Assembly (Procedure)	Ref.No./Steps	Metric	U.S.
<b>Cylinder Block - Torque Values</b>			
<b>Bearings, Connecting Rod (007-005)</b>			
	1	30 N•m	22 ft-lb
	2	60 N•m	44 ft-lb
	3	Turn clockwise 60 degrees	
	<b>Oil pan</b> Lubricating Oil Pan		24 N•m 18 ft-lb
	<b>Suction tube</b> Lubricating Suction Tube		24 N•m 18 ft-lb
	<b>Bearings, Main (001-006)</b>		
	<b>Main bearing capscrew torque</b>		
	1	60 N•m	44 ft-lb
2	90 N•m	66 ft-lb	
3	Turn clockwise 90 degrees.		
	<b>Camshaft (001-008)</b>		
	<b>Thrust washer capscrew torque</b>		24 N•m 18 ft-lb
	<b>Camshaft Gear (Camshaft Removed) (001-013)</b>		
	1	27 N•m	20 ft-lb
	2	Turn capscrew clockwise 180 degrees.	
	<b>Connecting Rod (001-014)</b>		
			100 N•m 74 ft-lb
	<b>Crankshaft (001-016)</b>		
	1	60 N•m	44 ft-lb
2	90 N•m	66 ft-lb	
3	Turn clockwise 90 degrees		

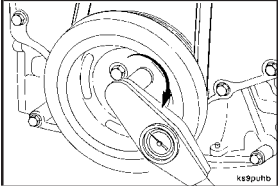
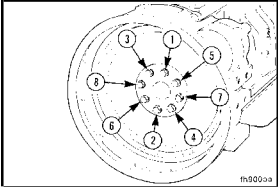
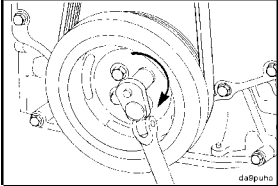
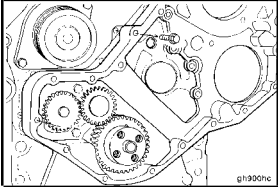
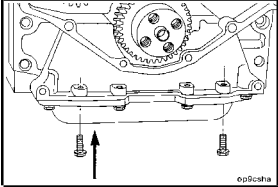
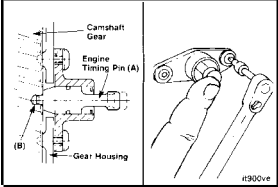
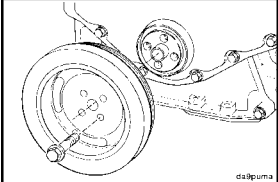
Component or Assembly (Procedure)	Ref.No./Steps	Metric	U.S.	
<b>Crankshaft Seal, Front (001-023)</b> Crankshaft pulley capscrew torque		125 N•m	92 ft-lb	
<b>Crankshaft Seal, Rear (001-024)</b> Flywheel capscrew torque		137 N•m	101 ft-lb	
<b>Gear Cover, Front (001-031)</b> Crankshaft pulley capscrews		125 N•m	92 ft-lb	
<b>Gear Housing, Front (001-033)</b> Gear housing capscrew torque		24 N•m	18 ft-lb	
Oil pan capscrew torque		24 N•m	18 ft-lb	
<b>Timing Pin Housing (001-049)</b> Capscrew torque		5 N•m	48 in-lb	
<b>Vibration Damper (001-052)</b> Crankshaft damper capscrew torque		125 N•m	92 ft-lb	

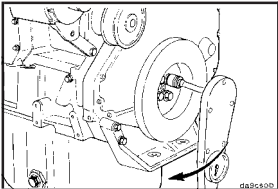
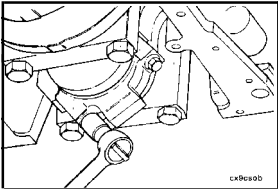
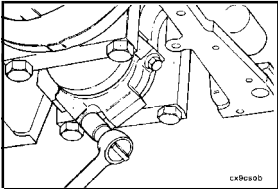
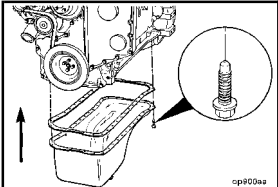
	Component or Assembly (Procedure)	Ref.No./Steps	Metric	U.S.
	<b>Vibration Damper Capscrews</b> <b>Crankshaft Pulley Mounting Capscrews</b>	200 N•m 77 N•m	148 ft-lb 57 ft-lb	
	<b>Piston and Connecting Rod Assembly (001-054)</b> <b>Connecting rod capscrew torque</b>	35 N•m	26 ft-lb	
	<b>Connecting rod capscrew torque</b>	1 2 3	30 N•m 60 N•m Turn 60 degrees clockwise.	22 ft-lb 44 ft-lb
	<b>Oil pan capscrew torque</b>	24 N•m	18 ft-lb	

Component or Assembly (Procedure)	Ref.No./Steps	Metric	U.S.
-----------------------------------	---------------	--------	------

### Cylinder Head - Specifications

Cylinder Head Weight		
Cylinder No.	Kg	lb
4	36	79
6	51.3	113

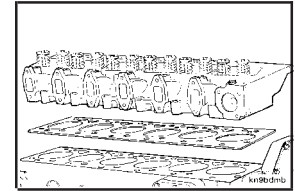

<b>Cylinder Head Flatness (6B engine)</b>			
End-to-End	0.305 mm	MAX	0.012 in
Side-to-Side	0.076 mm	MAX	0.003 in
<b>Cylinder Head Flatness (4B engine)</b>			
End-to-End	0.203 mm	MAX	0.008 in
Side-to-Side	0.305 mm	MAX	0.012 in

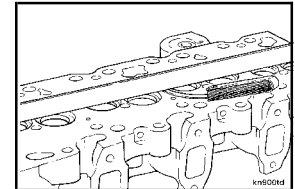

<b>Capscrew Free Length</b>			
Short	71.5 mm	MAX	2.815 in
Medium	122.1 mm	MAX	4.807 in
Long	182.9 mm	MAX	7.201 in

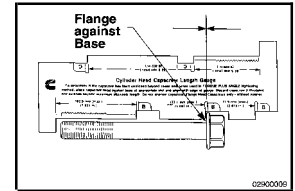

### Valve, Cylinder Head (002-020)

<b>Valve Guide Bore Diameter</b>			
	8.019 mm	MIN	0.3157 in
	8.090 mm	MAX	0.3185 in

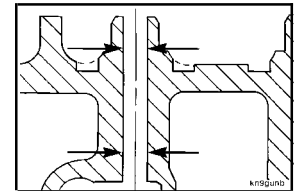

<b>Valve Stem Diameter</b>			
	7.94 mm	MIN	0.3126 ft-lb
	7.98 mm	MAX	0.3142 ft-lb

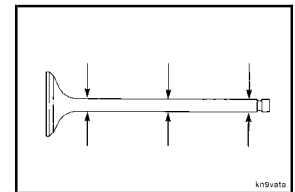

<b>Valve Rim Thickness Limit</b>	0.79 mm	MIN	0.031 in
----------------------------------	---------	-----	----------

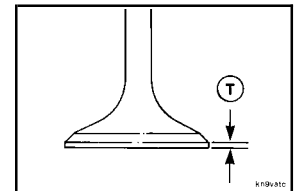

<b>Valve spring free length</b>			
Approx. Free Length (L):			
1991	55.63 mm		2.190 in
Maximum Inclination:			
1991	1.00 mm		0.039 in
Approx. Free Length (L):			
1994	60.00 mm		2.362 in
Maximum Inclination:			
1994	1.00 mm		0.039 in

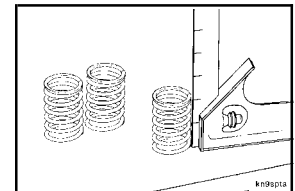

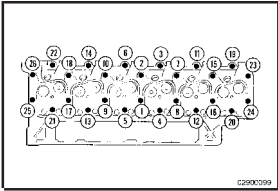
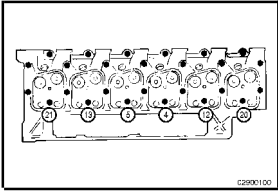
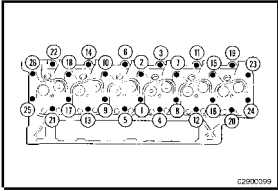
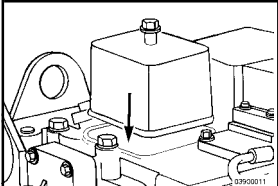
Component or Assembly (Procedure)	Ref.No./Steps	Metric	U.S.
	<p><b>Cylinder Head - Torque Values</b> Cylinder Head (002-004)</p>	<p>(Step 1) 90 N•m</p>	<p>66 ft-lb</p>
		<p>(Step 2) 120 N•m</p>	<p>89 ft-lb</p>
		<p>(Step 1) 90 N•m</p>	<p>66 ft-lb</p>
		<p><b>Valve, Cylinder Head (002-020)</b> Valve cover capscrew torque</p>	<p>24 N•m</p>



Component or Assembly (Procedure)	Ref.No./Steps	Metric	U.S.
-----------------------------------	---------------	--------	------

**Rocker Levers - Specifications  
Overhead Set (003-004)**

Intake Clearance:	0.254 mm		0.010 in
Exhaust Clearance:	0.508 mm		0.020 in

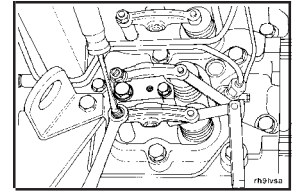

**Rocker Lever (003-008)**

Rocker Lever Bore	19.00 mm	MIN	0.748 in
-------------------	----------	-----	----------

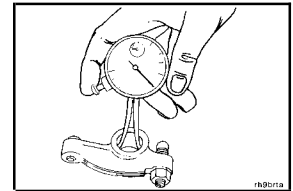

**Rocker Lever Shaft**

	18.98 mm	MAX	0.747 in
--	----------	-----	----------

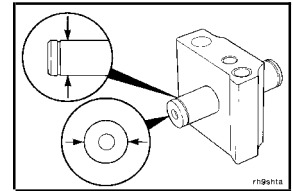

Component or Assembly (Procedure)	Ref.No./Steps	Metric	U.S.
-----------------------------------	---------------	--------	------

**Rocker Levers - Torque Values**  
**Rocker Lever Cover (003-011)**

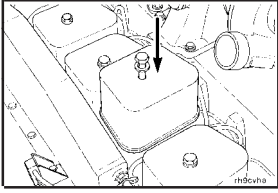

24 N•m

18 ft-lb

Component or Assembly (Procedure)	Ref.No./Steps	Metric	U.S.
-----------------------------------	---------------	--------	------

**Cam Followers/Tappets - Specifications**  
**Tappet (004-015)**

Valve Tappet Stem Diameter

15.936 mm	MIN	0.627 in
15.977 mm	MAX	0.629 in

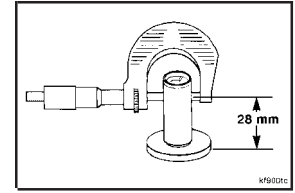

Component or Assembly (Procedure)	Ref.No./Steps	Metric	U.S.
-----------------------------------	---------------	--------	------

**Cam Followers/Tappets - Torque Values  
Push Rods or Tubes (004-014)**

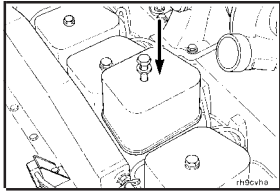

Rocker lever cover capscrew torque		24 N•m	18 ft-lb
------------------------------------	--	--------	----------

Component or Assembly (Procedure)	Ref.No./Steps	Metric	U.S.
-----------------------------------	---------------	--------	------

**Fuel System - Specifications**  
**Fuel Flow (005-011)**

**Fuel Transfer Pump Output Pressure at Rated Speed**

High-flow-automotive  
Low-flow-industrial

172 kPa	MIN	25 psi
83 kPa	MIN	12 psi

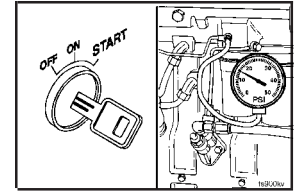

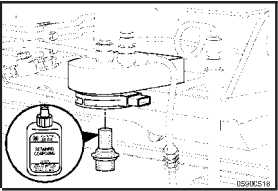
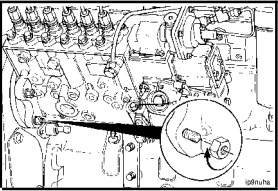
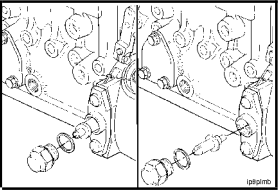
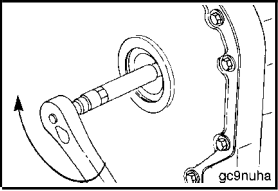
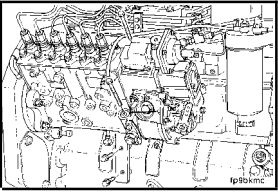
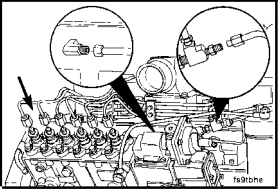
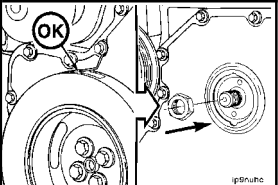
	Component or Assembly (Procedure)	Ref.No./Steps	Metric	U.S.
	<b>Fuel System - Torque Values Engine Fuel Heater, Electric (005-008)</b>			
	Fuel filter spud with a fuel heater		41 N•m	30 ft-lb
	Fuel filter spud without a fuel heater		27 N•m	20 ft-lb
	<b>Fuel Injection Pumps, In-Line (005-012)</b>			
	Mounting nut		43 N•m	32 ft-lb
	Mounting nut		32 N•m	24 ft-lb
	<b>Timing pin</b>		27 N•m	20 ft-lb
	<b>Fuel Injection Pump Drive Nut</b> "A" Pump P3000/P7100 Nippondenso		85 N•m	63 ft-lb
			195 N•m	144 ft-lb
			123 N•m	91 ft-lb
	<b>Fuel lines</b> High-Pressure Fuel Lines Low-Pressure Fuel Supply Fitting		24 N•m	18 ft-lb
			30 N•m	22 ft-lb
			15 N•m	133 in-lb
	<b>Fuel Injection Pump, In-Line, Spill Port Timing (005-013)</b>			
	<b>Fuel Injection Pump Drive Nut</b> "A" Pump P3000/P7100		85 N•m	63 ft-lb
			195 N•m	144 ft-lb

Component or Assembly (Procedure)	Ref.No./Steps	Metric	U.S.	
<b>Injection Pump Drive Gear Specification</b>				
Nippondenso		123 N•m	91 ft-lb	
Bosch® "A" Pump		85 N•m	63 ft-lb	
Bosch® In-Line (P3000/P7100) Pump		195 N•m	144 ft-lb	
<b>Delivery valve holding nut</b>	1 2	40 N•m 115 N•m	29 ft-lb 85 ft-lb	
<b>Fuel Injection Pump, Rotary (005-013)</b>				
<b>Mounting capscrew</b>		7 N•m	62 in-lb	
<b>Locking nut</b>		12 N•m	106 in-lb	
<b>Locking timing nut</b>		30 N•m	22 ft-lb	
<b>Fuel pump shaft gear nut</b>		15 to 20 N•m	133 to 177 in-lb	
<b>Timing nut</b>		24 N•m	18 ft-lb	

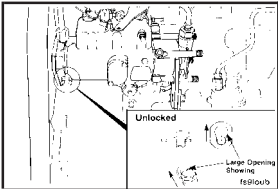
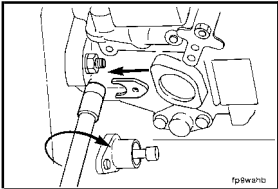
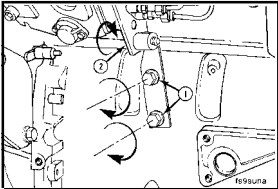
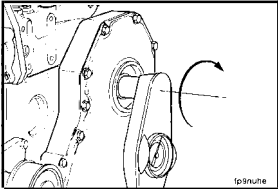
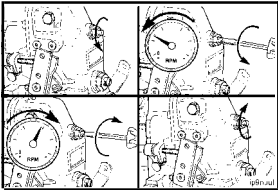
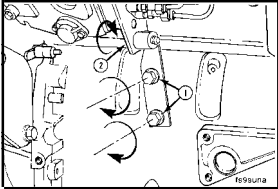
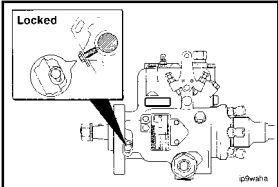
	Component or Assembly (Procedure)	Ref.No./Steps	Metric	U.S.
	Locking nut		20 N•m	15 ft-lb
	Bracket cap screw		13 N•m	115 in-lb
			24 N•m	18 ft-lb
	Bosch® VE (M14-1.5 nut) Bosch® VE (M12 nut) Lucas CAV/DPA Stanadyne		98 N•m 65 N•m 81 N•m 196 N•m	72 ft-lb 48 ft-lb 60 ft-lb 145 ft-lb
	<b>Fuel Pump Idle Speed (005-013)</b> Idle screw		8 N•m	71 in-lb
	<b>Fuel Pump Support Bracket (005-013)</b> Bracket cap screw		24 N•m	18 ft-lb
	<b>Fuel Pump Timing (005-013)</b> Timing nut		11.9 N•m	105 in-lb

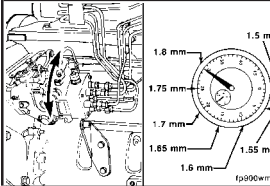
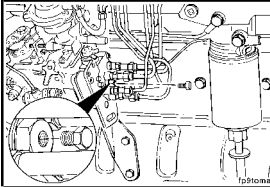
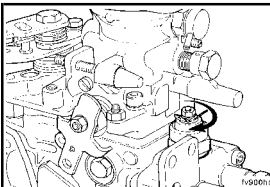
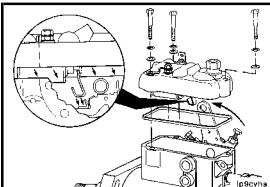
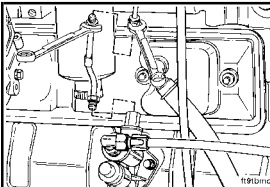
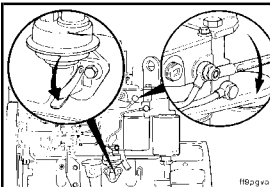

Component or Assembly (Procedure)	Ref.No./Steps	Metric	U.S.	
Mounting nuts		24 N•m	18 ft-lb	
Plug		10 N•m	89 in-lb	
<b>Fuel Shutoff Valve (005-043)</b> Nut		43 N•m	32 ft-lb	
Housing capscrew		4.6 N•m	41 in-lb	
<b>Fuel Lift Pump (005-045)</b> Mounting capscrew		24 N•m	18 ft-lb	
Fuel line to filter head		24 N•m	18 ft-lb	
Low-pressure fuel line		9 N•m	80 in-lb	

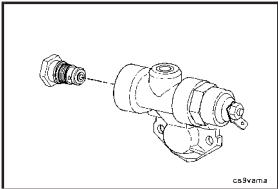
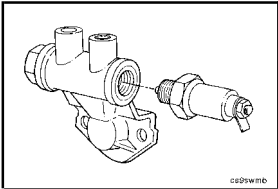
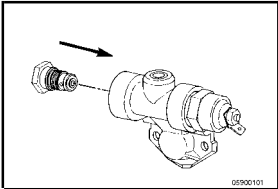
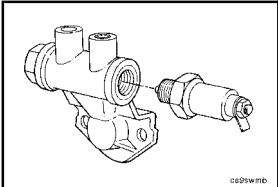
	Component or Assembly (Procedure)	Ref.No./Steps	Metric	U.S.
	<b>Cold Start Timing Advance System (KSB) Remote (005-046)</b>			
	Pressure relief valve		13 N•m	115 in-lb
	Electrical solenoid		22 N•m	16 ft-lb
	<b>Cold Start Timing Advance System (KSB) Temperature Switch (005-069)</b>			
	Pressure relief valve		13 N•m	115 in-lb
	<b>Cold Start Timing Advance System (KSB) Pump Mounted (005-070)</b>			
	Electrical solenoid		22 N•m	16 ft-lb

Component or Assembly (Procedure)	Ref.No./Steps	Metric	U.S.
-----------------------------------	---------------	--------	------

**Injectors and Fuel Lines - Specifications**  
**Fuel Drain Line Restriction (006-012)**

Fuel Drain Line Restriction

518 mm Hg      MAX    20.4 in Hg

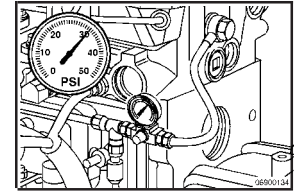

**Fuel Inlet Restriction (006-020)**

Allowable Inlet Restriction at Low/High  
Idle

101.6 mm Hg      MAX    4.0 in Hg

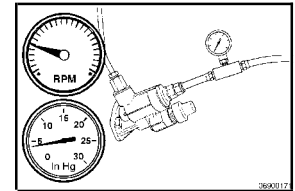

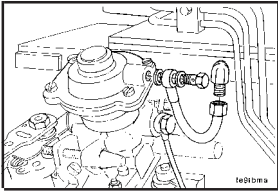
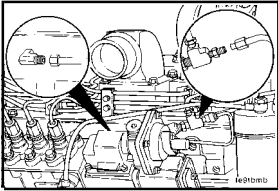
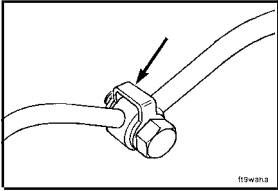
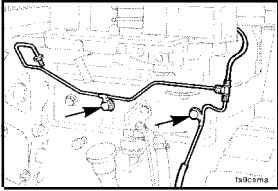
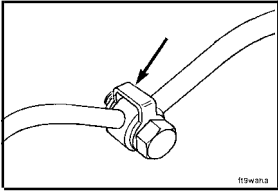
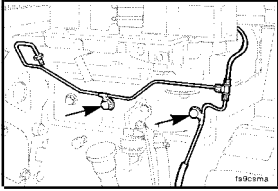
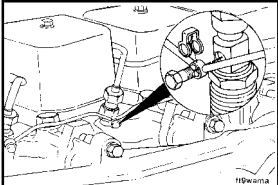
	Component or Assembly (Procedure)	Ref.No./Steps	Metric	U.S.
	<b>Injectors and Fuel Lines - Torque Values</b> <b>AFC Air Tube (006-001)</b>	AFC tube	9 N•m	80 in-lb
			24 N•m	18 ft-lb
	<b>Fuel Drain Line Restriction (006-012)</b>		9 N•m	80 in-lb
			24 N•m	18 ft-lb
	<b>Fuel Manifold (Drain) (006-021)</b>		9 N•m	80 in-lb
			24 N•m	18 ft-lb
	Injector Banjo Fuel Filter Head		9 N•m 13 N•m	80 in-lb 115 in-lb

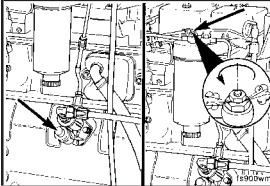
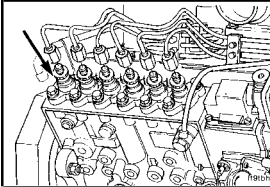
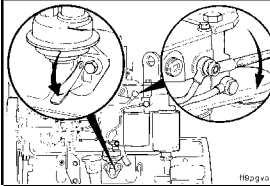
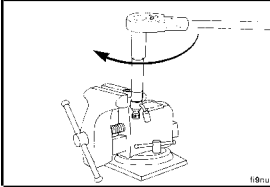
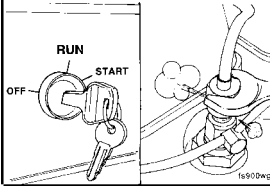
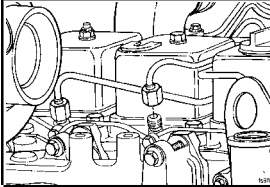
Component or Assembly (Procedure)	Ref.No./Steps	Metric	U.S.	
<b>Fuel Supply Lines (006-024)</b>		9 N•m	80 in-lb	
(Line Fittings)		24 N•m	18 ft-lb	
(Support Clamp)		6 N•m	35 in-lb	
(Support Bracket)		24 N•m	18 ft-lb	
<b>Low-pressure fuel lines</b>		9 N•m	80 in-lb	
<b>Injector (006-026)</b>		30 N•m	22 ft-lb	
		38 N•m	28 ft-lb	
<b>Injector Supply Lines (High Pressure) (006-051)</b>		24 N•m	18 ft-lb	
		38 N•m	28 ft-lb	

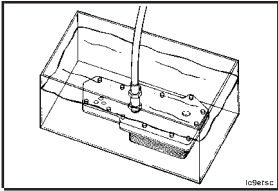
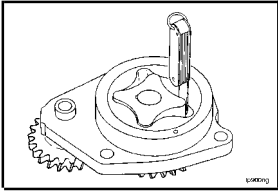
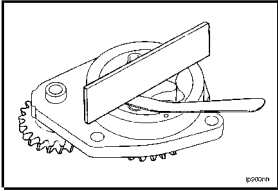
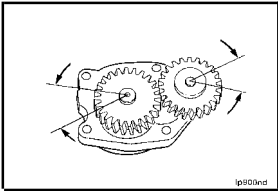
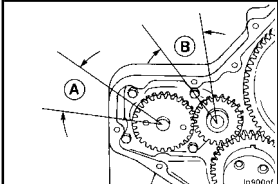
Component or Assembly (Procedure)	Ref.No./Steps	Metric		U.S.	
<b>Lubricating Oil System - Specifications</b> <b>Lubricating Oil Cooler (007-003)</b>					
	Air Pressure Test	449 kPa	MIN	65 psi	
		518 kPa	MAX	75 psi	
<b>Lubricating Oil Pump (007-031)</b>					
	Limit	0.1778 mm	MAX	0.007 in	
		Limit	0.127 mm	MAX	0.005 in
	Limit		0.381 mm	MAX	0.015 in
		Limits (Used Pump)	0.076 mm	MIN	0.003 in
	0.330 mm		MAX	0.013 in	
		Backlash Limits	0.076 mm	MIN	0.003 in
A			0.330 mm	MAX	0.013 in
B			0.076 mm	MIN	0.003 in
0.330 mm			MAX	0.013 in	

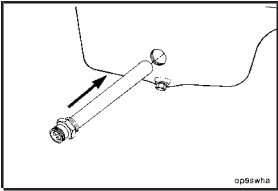
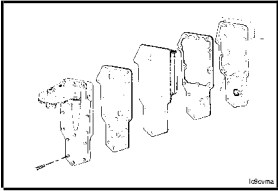
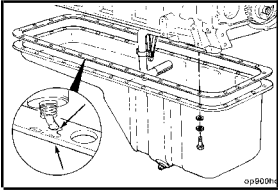
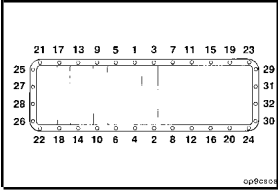
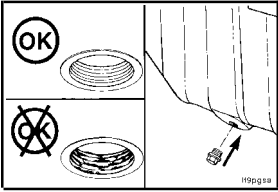
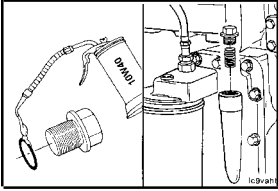
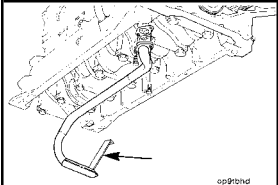
Component or Assembly (Procedure)	Ref.No./Steps	Metric	U.S.
<b>Lubricating Oil System - Torque Values</b>			
<b>Engine Oil Heater (007-001)</b>			
Heater element torque		80 N•m	59 ft-lb
			
<b>Lubricating Oil Cooler (007-003)</b>			
Lubricating oil cooler capscrew torque		24 N•m	18 ft-lb
			
<b>Lubricating Oil Pan (007-025)</b>			
Lubricating oil pan capscrew torque		24 N•m	18 ft-lb
			
		24 N•m	18 ft-lb
			
Lubricating oil pan drain plug		60 N•m	44 ft-lb
			
<b>Lubricating Oil Pressure Regulator (Main Rifle) (007-029)</b>			
Lubricating oil pressure regulator torque		80 N•m	59 ft-lb
			
<b>Lubricating Oil Suction Tube (Block-Mounted) (007-035)</b>			
Lubricating oil suction tube capscrew torque		24 N•m	18 ft-lb
			

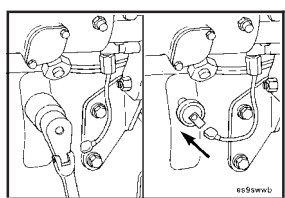
Component or Assembly (Procedure)	Ref.No./Steps	Metric	U.S.
	<p><b>Lubricating Oil Pressure Sensor, OEM (007-052)</b></p>	<p>Lubricating oil pressure switch torque (Installed into Cast Iron) 16 N•m (Installed into Aluminum) 10 N•m</p>	<p>142 in-lb 89 in-lb</p>



Component or Assembly (Procedure)	Ref.No./Steps	Metric	U.S.
-----------------------------------	---------------	--------	------

**Cooling System - Specifications**  
**Coolant Thermostat (008-013)**

Flow Valve and Flange Clearance

6.6 mm MIN 0.26 in

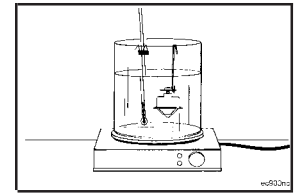

**Radiator Cap Pressure Test**

	System	Cap
A-Normal-Duty	104°C [219°F]	103 kPa [15 psi]
B-Light-Duty	99°C [210°F]	48 kPa [7 psi]

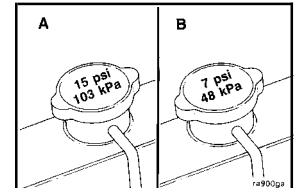

**Coolant Capacity (engine only)**

- 4B3.9, 4BT3.9
- 4BTA3.9
- 6B5.9, 6BT5.9
- 6BTA5.9

7 liters MAX 1.85 U.S.gal  
 7.9 liters MAX 2.1 U.S.gal  
 9 liters MAX 2.38 U.S.gal  
 9.9 liters MAX 2.61 U.S.gal

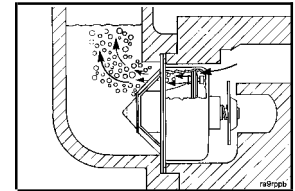

**Radiator Shutter Assembly (008-049)**

Winterfronts:

302<sup>2</sup> mm 60<sup>2</sup> in

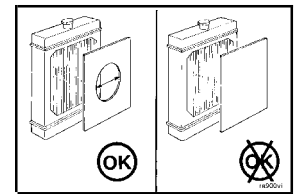

**Water Pump (008-062)**

Engine Temperature:

80 °C 180 °F

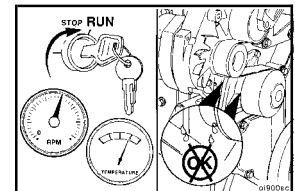

**Coolant Temperature Sensor, OEM (008-070)**

Sensor:

107 °C 225 °F

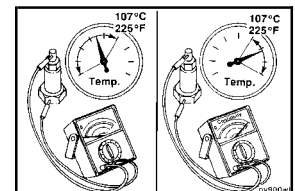

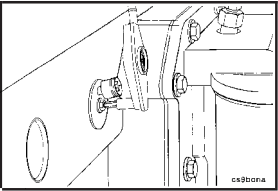
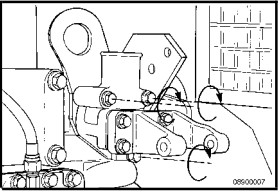
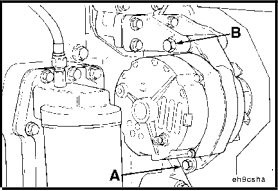
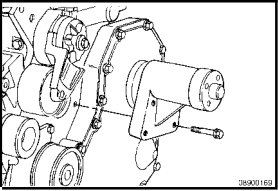
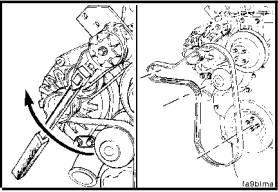
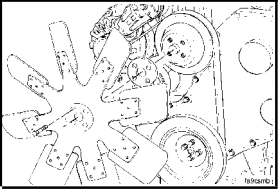
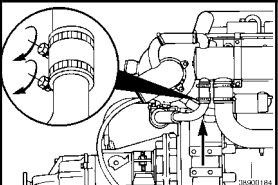
	Component or Assembly (Procedure)	Ref.No./Steps	Metric	U.S.
	<b>Cooling System - Torque Values</b> <b>Coolant Heater (008-011)</b>	Cylinder block water heater torque Minimum: Maximum:	1.3 N•m 2.8 N•m	12 in-lb 25 in-lb
	<b>Coolant Thermostat (008-013)</b>	Thermostat housing capscrew	24 N•m	18 ft-lb
	<b>Alternator capscrew torque</b>	(A) (B)	24 N•m 43 N•m	18 ft-lb 32 ft-lb
	<b>Fan Clutch, Electric (008-026)</b>		45 N•m	33 ft-lb
	<b>Fan Spacer and Pulley (008-039)</b>	Fan and fan spacer capscrew torque Fan and fan spacer capscrew torque	24 N•m 43 N•m	18 ft-lb 32 ft-lb
	<b>Fan, Cooling (008-040)</b>	Fan capscrews Fan capscrews	24 N•m 43 N•m	18 ft-lb 32 ft-lb
	<b>Sea Water Heat Exchanger (008-053)</b>	Water inlet connection	5 N•m	44 in-lb

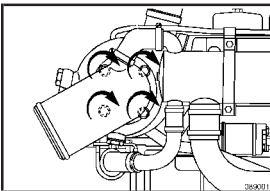
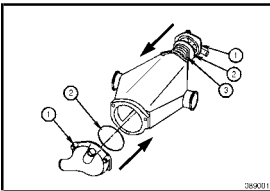
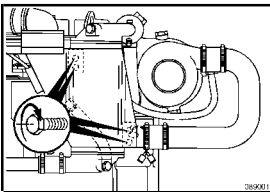
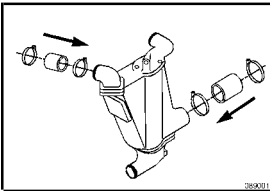
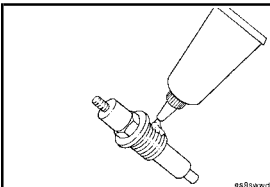
Component or Assembly (Procedure)	Ref.No./Steps	Metric	U.S.	
Mounting capscrew Elbow hose clamp		24 N•m 5 N•m	18 ft-lb 44 in-lb	
Housing core		30 N•m	22 ft-lb	
Aftercooler capscrew		30 N•m	22 ft-lb	
T-Bolt type T-Bolt Type Worm Type		8 N•m 5 N•m	71 in-lb 44 in-lb	
<b>Coolant Temperature Sensor, OEM (008-070)</b>				
(Installed into Cast Iron)		50 N•m	37 ft-lb	
(Installed into Aluminum)		30 N•m	22 ft-lb	

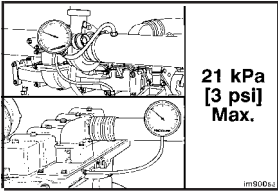
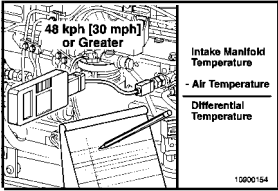
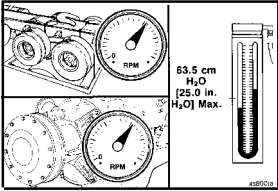
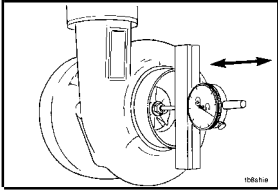
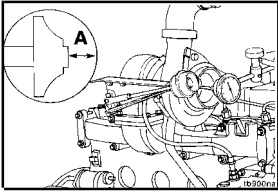
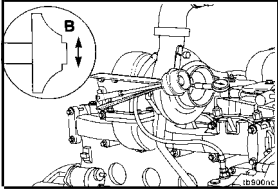
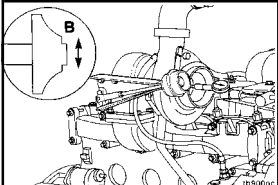
Component or Assembly (Procedure)	Ref.No./Steps	Metric	U.S.
	<b>Air Intake System - Specifications Charge-Air Cooler (CAC) (010-027)</b>	Differential Pressure:	21 kPa 3 psi
	<b>Charge air cooler temperature differential test</b> Perform a road test with the engine at peak power and a vehicle speed of 48 kph [30 mph] or greater.		
	<b>Air Intake Restriction (010-031)</b> Inlet Air Restriction Turbocharged Naturally Aspirated	63.5 mm H <sub>2</sub> O 50.8 mm H <sub>2</sub> O	MAX 2.5 in H <sub>2</sub> O MAX 2 in H <sub>2</sub> O
	<b>Turbocharger (010-033)</b> End Play	0.03 mm 0.08 mm	MIN 0.001 in MAX 0.003 in
	<b>Turbocharger Axial Clearance (010-038)</b> Turbocharger Shaft End Play	* **	0.10 mm MIN 0.004 in 0.16 mm MAX 0.006 in 0.03 mm MIN 0.001 in 0.08 mm MAX 0.003 in
	<b>Radial Bearing Clearance</b>	0.30 mm 0.46 mm	MIN 0.012 in MAX 0.018 in
	<b>Turbocharger Radial Bearing Clearance (010-047)</b> Radial Bearing Clearance	0.30 mm 0.46 mm	MIN 0.012 in MAX 0.018 in

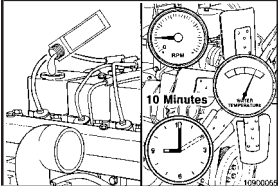
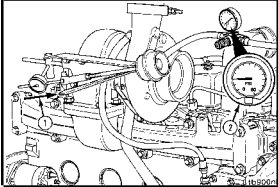
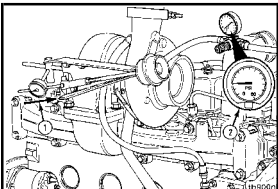
Component or Assembly (Procedure)	Ref.No./Steps	Metric	U.S.
<b>Turbocharger Turbine Seal Leaks (010-049)</b>			
Engine Lubricating Oil:		38 liters	10 U.S.gal
			
<b>Turbocharger Wastegate Actuator (010-050)</b>			
Air Pressure:		200 kPa	29 psi
Rod:		0.33 to 1.27 mm	0.013 to 0.050 in
			
<b>Wastegate Actuator Travel Measurement</b>			
		0.033 mm 1.27 mm	MIN MAX 0.013 in 0.050 in
			

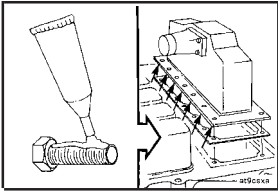
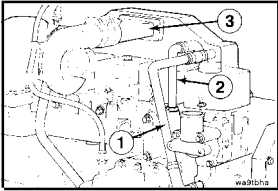
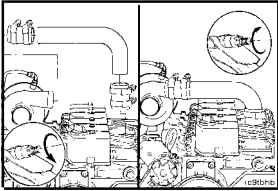
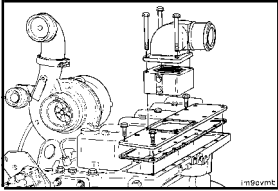
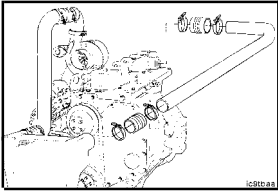
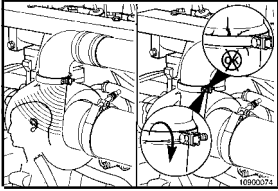
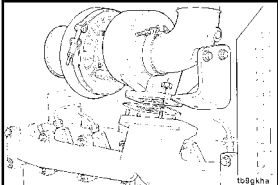
	Component or Assembly (Procedure)	Ref.No./Steps	Metric	U.S.
	<b>Air Intake System - Torque Values Aftercooler (010-001)</b>		24 N•m	18 ft-lb
	<b>Inlet connections</b>		8 N•m	71 in-lb
	<b>Air Crossover (010-019)</b>		8 N•m	71 in-lb
	<b>Air Intake Manifold (010-023)</b>		24 N•m	18 ft-lb
	<b>Manifold connection</b>		8 N•m	71 in-lb
	<b>Air Leaks, Air Intake and Exhaust Systems (010-024)</b>		8 N•m	71 in-lb
	<b>Turbocharger (010-033)</b>		45 N•m	33 ft-lb

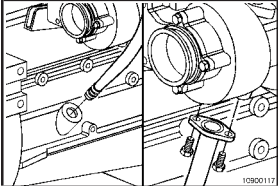
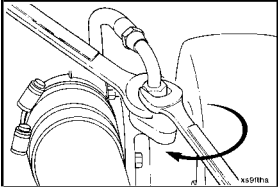
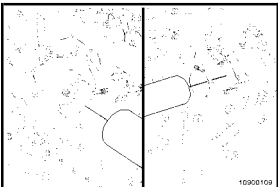
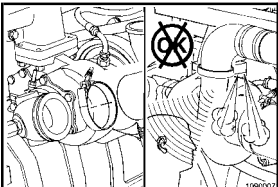
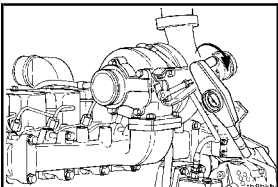
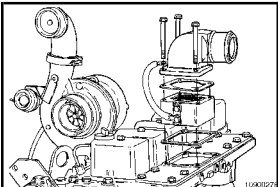
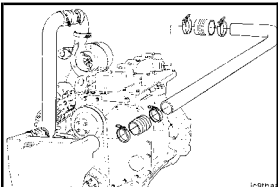
Component or Assembly (Procedure)	Ref.No./Steps	Metric	U.S.	
<b>Turbocharger Oil Drain Line (010-045)</b> Turbocharger drain line		24 N•m	18 ft-lb	
<b>Turbocharger Oil Supply Line (010-046)</b> Turbocharger oil supply line torque		24 N•m	18 ft-lb	
<b>Turbocharger Radial Bearing Clearance (010-047)</b> Intake and exhaust pipe clamps		8 N•m	71 in-lb	
<b>Turbocharger Turbine Seal Leaks (010-049)</b>		8 N•m	71 in-lb	
<b>Turbocharger Wastegate Actuator (010-050)</b>		4.5 N•m	40 in-lb	
<b>Air Intake Manifold Heater (010-072)</b> Grid heater mounting capscrews		24 N•m	18 ft-lb	
Air intake clamp capscrews		8 N•m	71 in-lb	

Component or Assembly (Procedure)	Ref.No./Steps	Metric	U.S.
-----------------------------------	---------------	--------	------

**Exhaust System - Specifications**  
**Exhaust Restriction (011-009)**

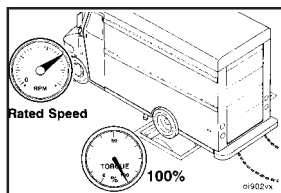

<b>Exhaust Restriction</b>			
Industrial		76 mm Hg	MAX 3 in Hg
1991 EPA Certification		114 mm Hg	MAX 4.5 in Hg
1994 EPA Certification with Oxidation Catalyst		152 mm Hg	MAX 6 in Hg



Component or Assembly (Procedure)	Ref.No./Steps	Metric	U.S.
-----------------------------------	---------------	--------	------

**Exhaust System - Torque Values**  
**Exhaust Manifold, Dry (011-007)**

Exhaust manifold capscrew torque

43 N•m

32 ft-lb

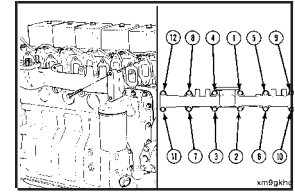

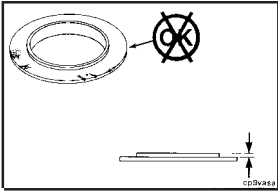
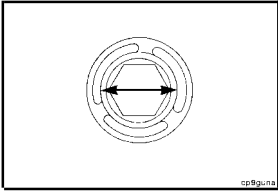
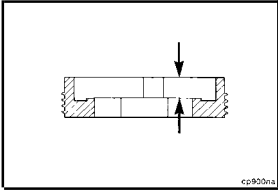
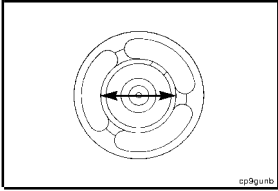
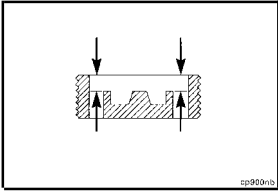
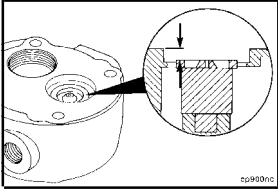
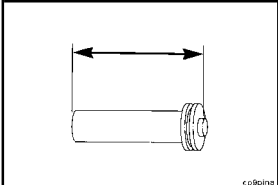
Component or Assembly (Procedure)	Ref.No./Steps	Metric	U.S.
<b>Compressed Air System - Specifications</b>			
<b>Air Compressor Cylinder Head (Holset® SS191 Model) (012-007)</b>			
		Intake Valve Seat	
			0.597 mm 0.673 mm
		Valve Guide Diameter	
			25.53 mm 25.65 mm
		Set Height	
			4.01 mm 4.11 mm
		Valve Guide Diameter	
			25.53 mm 25.65 mm
		Stop Depth	
			3.63 mm 3.78 mm
		Stop Height	
			4.42 mm 4.70 mm
		Pin Length	
			40.51 mm 40.72 mm

Component or Assembly (Procedure)	Ref.No./Steps	Metric	U.S.			
<b>Load Required to Compress Spring to Length</b>						
	<b>Spring Length</b>	<b>Minimum</b>		<b>Maximum</b>		
	<b>mm</b>	<b>in</b>	<b>Kg</b>	<b>lb</b>	<b>Kg</b>	<b>lb</b>
Inlet Valve	5.08	0.20	0.272	0.60	0.340	0.75
Unloader	10.0330	0.395	1.53	3.37	1.90	4.19
Exhaust Valve	5.08	0.20	0.272	0.60	0.340	0.75

**Air Compressor Cylinder Head (Holset® QE Models) (012-104)**

**Force Specification**

10.4 kg      MIN      23 lb  
12.5 kg      MAX      27 lb

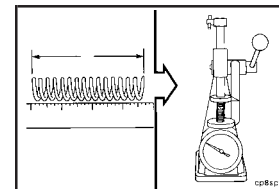

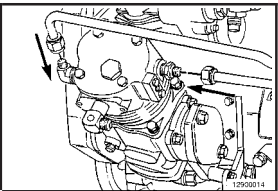
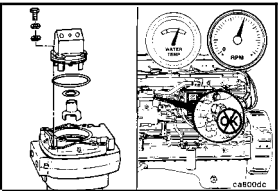
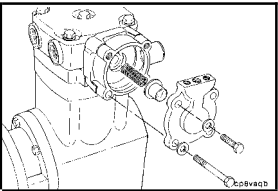
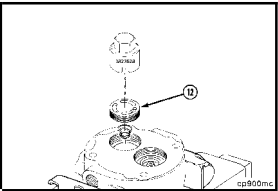
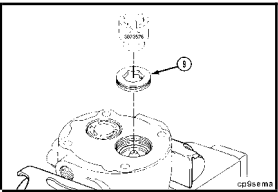
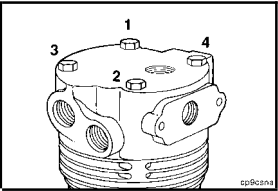
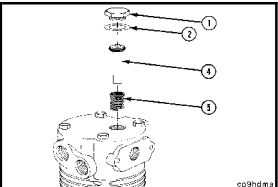
Component or Assembly (Procedure)	Ref.No./Steps	Metric	U.S.
	<p><b>Compressed Air System - Torque Values</b> <b>Air Compressor Coolant Lines (012-004)</b></p>	24 N•m	18 ft-lb
	<p><b>Air Compressor Unloader and Valve Assembly (012-013)</b> Holset® SS, E-type, and ST unloader</p>	14 N•m	124 in-lb
	<p>Holset® QE unloader</p>	27 N•m	20 ft-lb
	<p><b>Air Compressor Cylinder Head (Holset® SS191 Model) (012-007)</b> Air compressor inlet valve cage torque</p>	108 N•m	80 ft-lb
	<p>Exhaust valve seat</p>	108 N•m	80 ft-lb
	<p><b>Air compressor head capscrew torque</b> Tighten the capscrews again, in the sequence shown.</p>	30 N•m	22 ft-lb
	<p>Air compressor cover</p>	41 N•m	30 ft-lb

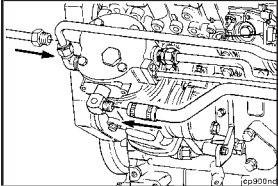
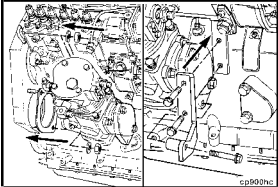
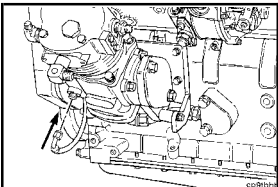
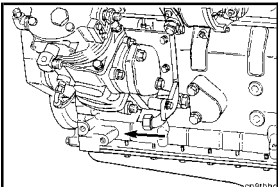
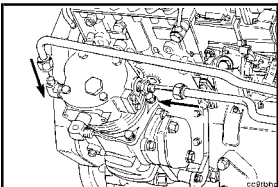
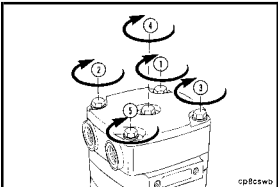
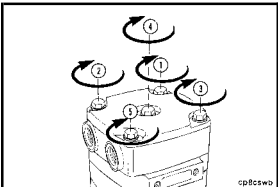
Component or Assembly (Procedure)	Ref.No./Steps	Metric	U.S.	
<b>Air compressor inlet and outlet torque</b> Inlet *Outlet		5 N•m 24 N•m	44 in-lb 18 ft-lb	
<b>Air compressor</b> Mounting Nuts Support Capscrews		77 N•m 24 N•m	57 ft-lb 18 ft-lb	
<b>Air compressor oil supply line</b>		15 N•m	133 in-lb	
<b>Air compressor oil drain line</b>		24 N•m	18 ft-lb	
<b>Air compressor support bracket</b>		24 N•m	18 ft-lb	
<b>Air Compressor Cylinder Head (Holset® QE Models) (012-104)</b> Holset® QE, Non-European cylinder head		28 N•m	21 ft-lb	
Holset® QE, European cylinder head		28 N•m	21 ft-lb	

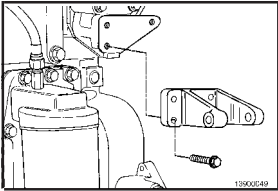
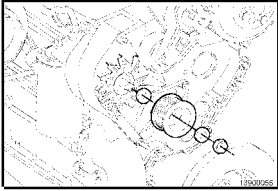
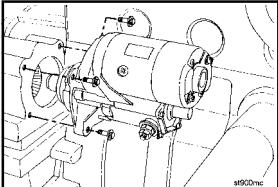
	Component or Assembly (Procedure)	Ref.No./Steps	Metric	U.S.
	<p><b>Electrical Equipment - Torque Values</b> <b>Alternator Bracket (013-003)</b></p>		24 N•m	18 ft-lb
	<p><b>Alternator Pulley (013-006)</b></p>		80 N•m	59 ft-lb
	<p><b>Starting Motor (013-020)</b> Starting motor capscrew torque</p>		43 N•m	32 ft-lb

Component or Assembly (Procedure)	Ref.No./Steps	Metric	U.S.
-----------------------------------	---------------	--------	------

**Engine Testing - Specifications**  
**Engine Testing (Chassis Dynamometer) (014-002)**

Minimum Gauge Capacity: 415 kPa 60 psi

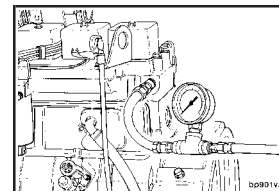

Minimum Gauge Capacity: 1905 mm Hg 75 in Hg

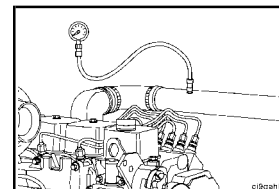

Minimum Gauge Capacity: 760 mm H<sub>2</sub>O 30 in H<sub>2</sub>O

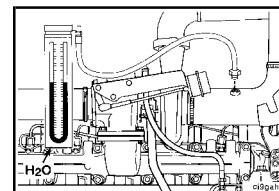

Minimum Gauge Capacity: 1270 mm H<sub>2</sub>O 50 in H<sub>2</sub>O

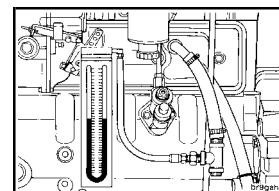

**Engine Testing (Engine Dynamometer) (014-005)**

Minimum Gauge Capacity: 107 °C 225 °F

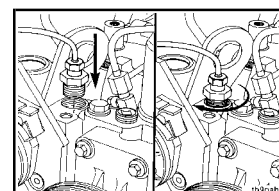

Minimum Gauge Capacity: 760 mm H<sub>2</sub>O 30 in H<sub>2</sub>O

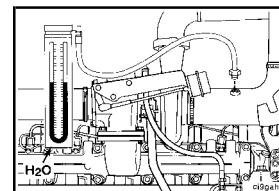

Minimum Gauge Capacity: 254 mm Hg 10 in Hg

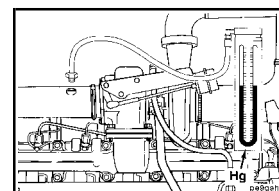

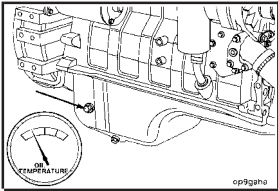
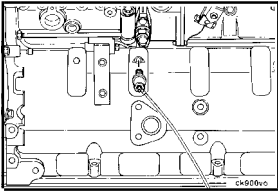
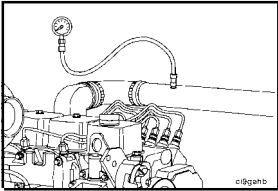
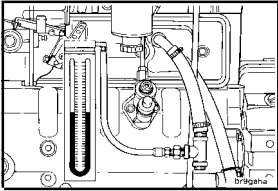
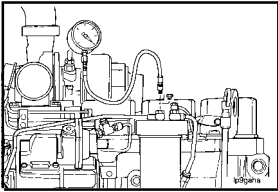
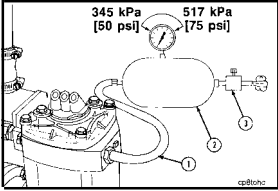
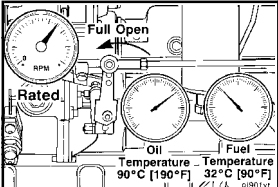
Component or Assembly (Procedure)	Ref.No./Steps	Metric	U.S.
	Minimum Gauge Capacity:	150 °C	302 °F
	Minimum Gauge Capacity:	1034 kPa	150 psi
	Minimum Gauge Capacity:	1905 mm Hg	75 in Hg
	Minimum Gauge Capacity:	1270 mm H <sub>2</sub> O	50 in H <sub>2</sub> O
	Minimum Gauge Capacity:	760 mm Hg	30 in Hg
	Hose Temperature (Minimum):	260 °C	500 °F
	<b>Engine Testing (In Chassis) (014-008)</b> Lubricating Oil Temperature Fuel Temperature	90 °C 32 °C	194 °F 90 °F



Component or Assembly (Procedure)	Ref.No./Steps	Metric	U.S.
-----------------------------------	---------------	--------	------

### Mounting Adaptations - Specifications

Flywheel Radius (A)		Maximum of Flywheel Face	
mm	in	mm	in
203	8	0.203	0.008
254	10	0.254	0.010
305	12	0.305	0.012
356	14	0.356	0.014
406	16	0.406	0.016

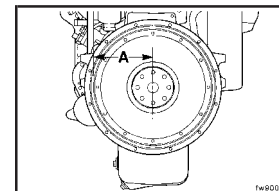

SAE No.	Bore Diameter		TIR Max	
	mm	in	mm	in
2	447.68 to	17.625 to	0.20	0.008
	447.80	17.30		
3	409.58 to	16.125 to	0.20	0.008
	409.70	16.130		

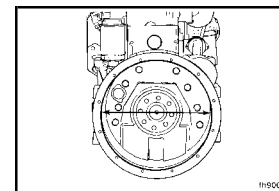

Set Screw Installation Depth (Flywheel Housing)

3.00 mm      MAX      0.118 in

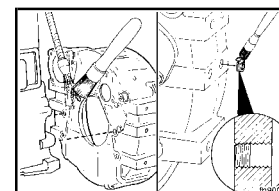

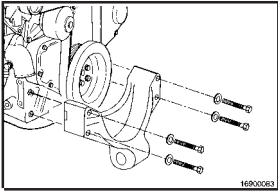
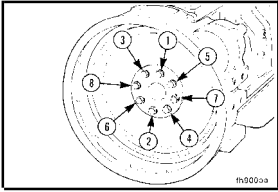
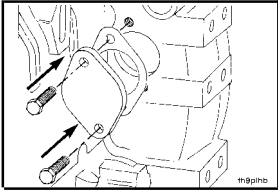
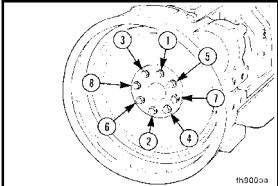
	Component or Assembly (Procedure)	Ref.No./Steps	Metric	U.S.
	<p><b>Mounting Adaptations - Torque Values</b> <b>Engine Support Bracket, Front (016-002)</b></p>		68 N•m	50 ft-lb
	<p><b>Flywheel (016-005)</b> Flywheel capscrew torque</p>		137 N•m	101 ft-lb
	<p><b>Flywheel Housing (016-006)</b> Flywheel housing access plate capscrew</p>		24 N•m	18 ft-lb
	<p><b>Flywheel Ring Gear (016-008)</b> Flywheel capscrews torque</p>		137 N•m	101 ft-lb

## Specifications

### General Specifications

#### General Engine Data (automotive)

	<b>B3.9</b>	<b>B5.9</b>
Bore	102 mm [4.02 in]	102 mm [4.02 in]
Stroke	120 mm [4.72 in]	120 mm [4.72 in]
Displacement	3.9 liters [238 in <sup>3</sup> ]	5.9 liters [360 in <sup>3</sup> ]
Engine Weight (dry) Less Flywheel and Electric Components	308 to 329 kg [679 to 725 lb]	388 to 411 kg [855 to 906 lb]
Firing Order	1, 3, 4, 2	1, 5, 3, 6, 2, 4
Valve Clearances:		
-Intake	0.25 mm [0.010 in]	0.25 mm [0.010 in]
-Exhaust	0.51 mm [0.020 in]	0.51 mm [0.020 in]
Compression Ratio	(Rotary Pump) 17.6:1	(In-Line Pump) 17.9:1
Rotation, Viewed from the Front of the Engine	<b>Clockwise</b>	<b>Clockwise</b>
Aspiration:		
- Turbocharged	X	X
- Charge-Air Cooled	X	X

**General 4B Engine Data (nonautomotive)**

	<b>4B3.9</b>	<b>4BT3.9</b>	<b>4BTA3.9</b>
Bore	102 mm [4.02 in]	102 mm [4.02 in]	102 mm [4.02 in]
Stroke	120 mm [4.72 in]	120 mm [4.72 in]	120 mm [4.72 in]
Displacement	3.9 liters [238 in <sup>3</sup> ]	3.9 liters [238 in <sup>3</sup> ]	3.9 liters [238 in <sup>3</sup> ]
Engine Weight (dry) Less Flywheel and Electric Components	308 kg [679 lb]	320 kg [705 lb]	329 kg [725 lb]
Firing Order	1, 3, 4, 2	1, 3, 4, 2	1, 3, 4, 2
Valve Clearances:			
- Intake	0.25 mm [0.010 in]	0.25 mm [0.010 in]	0.25 mm [0.010 in]
- Exhaust	0.51 mm [0.020 in]	0.51 mm [0.020 in]	0.51 mm [0.020 in]
Compression Ratio	18.5:1	17.5:1	16.5:1
Rotation, Viewed from the Front of the Engine	<b>Clockwise</b>	<b>Clockwise</b>	<b>Clockwise</b>
Aspiration:			
- Naturally Aspirated	X		
- Turbocharged		X	X
- Aftercooled			X

**General 6B Engine Data (nonautomotive)**

	<b>6B5.9</b>	<b>6BT5.9</b>	<b>6BTA5.9</b>
Bore	102 mm [4.02 in]	102 mm [4.02 in]	102 mm [4.02 in]
Stroke	120 mm [4.72 in]	120 mm [4.72 in]	120 mm [4.72 in]
Displacement	5.88 liters [359 in <sup>3</sup> ]	5.88 liters [359 in <sup>3</sup> ]	5.88 liters [359 in <sup>3</sup> ]
Engine Weight (dry) Less Flywheel and Electric Components	388 kg [855 lb]	399 kg [880 lb]	411 kg [906 lb]
Firing Order	1, 5, 3, 6, 2, 4	1, 5, 3, 6, 2, 4	1, 5, 3, 6, 2, 4
Valve Clearances:			
- Intake	0.25 mm [0.010 in]	0.25 mm [0.010 in]	0.25 mm [0.010 in]
- Exhaust	0.51 mm [0.020 in]	0.51 mm [0.020 in]	0.51 mm [0.020 in]
Compression Ratio	18.5:1	17.5:1	16.5:1
Rotation, Viewed from the Front of the Engine	<b>Clockwise</b>	<b>Clockwise</b>	<b>Clockwise</b>
Aspiration:			
- Naturally Aspirated	X		
- Turbocharged		X	X
- Aftercooled			X

**Fuel System**

**Fuel System Data (automotive)**

<b>Distributor-Type Fuel Injection Pumps</b>	<b>B3.9</b>	<b>B5.9</b>
Maximum Inlet Restriction to the Fuel Transfer Pump <b>Must Not</b> Exceed	100 mm Hg [4 in Hg]	100 mm Hg [4 in Hg]
Maximum Allowable Return Line Restriction	518 mm Hg [20.4 in Hg]	518 mm Hg [20.4 in Hg]
Maximum Allowable Pressure Drop across Fuel Filter	35 kPa [5 psi]	35 kPa [5 psi]
Maximum Inlet Pressure to the Injection Pump <b>Must Not</b> Exceed	70 kPa [10 psi]	70 kPa [10 psi]
<b>In-Line-Type Fuel Injection Pumps</b>	<b>B3.9</b>	<b>B5.9</b>
Maximum Inlet Restriction to the Fuel Transfer Pump <b>Must Not</b> Exceed	100 mm Hg [4 in Hg]	100 mm Hg [4 in Hg]
Fuel Transfer Pump Minimum Output Pressure	175 kPa [25 psi] @ Rated rpm	175 kPa [25 psi] @ Rated rpm
Fuel Filter Restriction (maximum pressure drop across filters)	35 kPa [5 psi]	35 kPa [5 psi]
Fuel Pressure Gallery Pressure	140 kPa [20 psi] @ Rated rpm	140 kPa [20 psi] @ Rated rpm
Fuel Return Maximum Restriction	518 mm Hg [20.4 in Hg]	518 mm Hg [20.4 in Hg]

4B Fuel System Data (nonautomotive)

Distributor-Type Fuel Injection Pumps	4B3.9	4BT3.9	4BTA3.9
Maximum Allowable Restriction to the Fuel Transfer Pump <b>Must Not Exceed</b>	100 mm Hg [4 in Hg]	100 mm Hg [4 in Hg]	100 mm Hg [4 in Hg]
Maximum Allowable Return Line Restriction	518 mm Hg [20.4 in Hg]	518 mm Hg [20.4 in Hg]	518 mm Hg [20.4 in Hg]
Maximum Allowable Pressure Drop across Fuel Filter	35 kPa [5 psi]	35 kPa [5 psi]	35 kPa [5 psi]
Maximum Inlet Pressure to the Injection Pump <b>Must Not Exceed</b>	70 kPa [10 psi]	70 kPa [10 psi]	70 kPa [10 psi]
<b>In-Line-Type Fuel Injection Pumps</b>			
Maximum Inlet Restriction to the Fuel Transfer Pump <b>Must Not Exceed</b>	100 mm Hg [4 in Hg]	100 mm Hg [4 in Hg]	100 mm Hg [4 in Hg]
Fuel Transfer Pump Minimum Output Pressure	172 kPa [25 psi] High Flow and 90 kPa [13 psi] Low Flow @ Rated rpm	172 kPa [25 psi] High Flow and 90 kPa [13 psi] Low Flow @ Rated rpm	172 kPa [25 psi] High Flow and 90 kPa [13 psi] Low Flow @ Rated rpm
Fuel Filter Restriction (maximum pressure drop across filters)	35 kPa [5 psi]	35 kPa [5 psi]	35 kPa [5 psi]
Fuel Pump Gallery Pressure	* 140 kPa [20 psi] @ Rated rpm	* 140 kPa [20 psi] @ Rated rpm	* 140 kPa [20 psi] @ Rated rpm
Fuel Return Maximum Restriction	518 mm Hg [20.4 in Hg]	518 mm Hg [20.4 in Hg]	518 mm Hg [20.4 in Hg]
* The low-flow fuel transfer pump will have 82.7 kPa [12 psi].			

6B Fuel System Data (nonautomotive)

Distributor-Type of Fuel Injection Pumps	6B5.9	6BT5.9	6BTA5.9
Maximum Allowable Restriction to the Fuel Transfer Pump <b>Must Not Exceed</b>	100 mm Hg [4 in Hg]	100 mm Hg [4 in Hg]	100 mm Hg [4 in Hg]
Maximum Allowable Return Line Restriction	518 mm Hg [20.4 in Hg]	518 mm Hg [20.4 in Hg]	518 mm Hg [20.4 in Hg]
Maximum Allowable Pressure Drop across Fuel Filter	35 kPa [5 psi]	35 kPa [5 psi]	35 kPa [5 psi]
Maximum Inlet Pressure to the Injection Pump <b>Must Not Exceed</b>	70 kPa [10 psi]	70 kPa [10 psi]	70 kPa [10 psi]
<b>In-Line-Type Fuel of Injection Pumps</b>			
Maximum Inlet Restriction to the Fuel Transfer Pump <b>Must Not Exceed</b>	100 mm Hg [4 in Hg]	100 mm Hg [4 in Hg]	100 mm Hg [4 in Hg]
Fuel Transfer Pump Minimum Output Pressure	172 kPa [25 psi] High Flow and 90 kPa [13 psi] Low Flow @ Rated rpm	172 kPa [25 psi] High Flow and 90 kPa [13 psi] Low Flow @ Rated rpm	172 kPa [25 psi] High Flow and 90 kPa [13 psi] Low Flow @ Rated rpm
Fuel Filter Restriction (maximum pressure drop across filters)	35 kPa [5 psi]	35 kPa [5 psi]	35 kPa [5 psi]
Fuel Pump Gallery Pressure	* 140 kPa [20 psi] @ Rated rpm	* 140 kPa [20 psi] @ Rated rpm	* 140 kPa [20 psi] @ Rated rpm
Fuel Return Maximum Restriction	518 mm Hg [20.4 in Hg]	518 mm Hg [20.4 in Hg]	518 mm Hg [20.4 in Hg]
* The low-flow fuel transfer pump will have 82.7 kPa [12 psi].			

**Lubricating Oil System**

**Lubrication System Data (automotive)**

	<b>B3.9</b>	<b>B5.9</b>
Lubricating Oil Pressure at Idle - (minimum allowable)	69 kPa [10 psi]	69 kPa [10 psi]
Lubricating Oil Pressure at Rated - (minimum allowable)	207 kPa [30 psi]	207 kPa [30 psi]
Regulating Valve Opening Pressure	449 kPa [65 psi]	449 kPa [65 psi]
Lubricating Oil Capacity:		
Standard Pan <b>Only</b>	9.5 liters [10 qt]	14.2 liters [15 qt]
Total System - Liters [U.S. qt]	11 liters [11.6 qt]	16.4 liters [17.3 qt]
Low to High	0.9 liter [1 qt]	1.9 liters [2 qt]

**4B Lubrication System Data (nonautomotive)**

	<b>4B3.9</b>	<b>4BT3.9</b>	<b>4BTA3.9</b>
Lubricating Oil Pressure at Idle - (minimum allowable)	69 kPa [10 psi]	69 kPa [10 psi]	69 kPa [10 psi]
Lubricating Oil Pressure at Rated - (minimum allowable)	207 kPa [30 psi]	207 kPa [30 psi]	207 kPa [30 psi]
Regulating Valve Opening Pressure	449 kPa [65 psi]	449 kPa [65 psi]	449 kPa [65 psi]
Lubricating Oil Capacity: Standard Pan <b>Only</b>	9.5 liters [10 qt]	9.5 liters [10 qt]	9.5 liters [10 qt]
Total System	10.9 liters [11.5 qt]	11 liters [11.6 qt]	11 liters [11.6 qt]
Low to High	0.9 liter [1 qt]	0.9 liter [1 qt]	0.9 liter [1 qt]

**6B Lubrication System Data (nonautomotive)**

	<b>6B5.9</b>	<b>6BT5.9</b>	<b>6BTA5.9</b>
Lubricating Oil Pressure at Idle - (minimum allowable)	69 kPa [10 psi]	69 kPa [10 psi]	69 kPa [10 psi]
Lubricating Oil Pressure at Rated - (minimum allowable)	207 kPa [30 psi]	207 kPa [30 psi]	207 kPa [30 psi]
Regulating Valve Opening Pressure	449 kPa [65 psi]	449 kPa [65 psi]	449 kPa [65 psi]
Lubricating Oil Capacity: Standard Pan <b>Only</b>	14.2 liters [15 qt]	14.2 liters [15 qt]	14.2 liters [15 qt]
Total System	16.3 liters [17.2 qt]	16.4 liters [17.3 qt]	16.4 liters [17.3 qt]
Low to High	1.9 liters [2 qt]	1.9 liters [2 qt]	1.9 liters [2 qt]



**Cooling System**

**Cooling System Data (automotive)**

	<b>B3.9</b>	<b>B5.9</b>
Coolant Capacity (engine <b>only</b> )	7 liters [7.4 qt]	10.5 liters [11.1 qt]
Standard Modulating Thermostat Range	Start 83°C [181°F]	Fully Open 95°C [203°F]
Pressure Cap:		
104°C [220°F] Systems	103 kPa [15 psi]	103 kPa [15 psi]
99°C [210°F] Systems	48 kPa [7 psi]	48 kPa [7 psi]

**4B Cooling System Data (nonautomotive)**

	<b>4B3.9</b>	<b>4BT3.9</b>	<b>4BTA3.9</b>
Coolant Capacity (engine <b>only</b> )	7 liters [7.4 qt]	7 liters [7.4 qt]	9.7 liters [10.2 qt]
Standard Modulating Thermostat Range	Start 83°C [181°F]; Fully Open 95°C [203°F]	Start 83°C [181°F]; Fully Open 95°C [203°F]	Start 83°C [181°F]; Fully Open 95°C [203°F]
Pressure Cap:			
104°C [220°F] Systems	103 kPa [15 psi]	103 kPa [15 psi]	103 kPa [15 psi]
99°C [210°F] Systems	48 kPa [7 psi]	48 kPa [7 psi]	48 kPa [7 psi]

**6B Cooling System Data (nonautomotive)**

	<b>6B5.9</b>	<b>6BT5.9</b>	<b>6BTA5.9</b>
Coolant Capacity (engine <b>only</b> )	10.5 liters [11.1 qt]	10.5 liters [11.1 qt]	14.5 liters [15.3 qt]
Standard Modulating Thermostat Range	Start 83°C [181°F]; Fully Open 95°C [203°F]	Start 83°C [181°F]; Fully Open 95°C [203°F]	Start 83°C [181°F]; Fully Open 95°C [203°F]
Pressure Cap:			
104°C [220°F] Systems	103 kPa [15 psi]	103 kPa [15 psi]	103 kPa [15 psi]
99°C [210°F] Systems	48 kPa [7 psi]	48 kPa [7 psi]	48 kPa [7 psi]

**Air Intake System**

**Air Intake System Data (automotive)**

	<b>B3.9</b>	<b>B5.9</b>
Maximum Allowable Intake Restriction at Rated Speed and Loaded with Dirty Air Filter Element	635 mm H <sub>2</sub> O [25 in H <sub>2</sub> O]	635 mm H <sub>2</sub> O [25 in H <sub>2</sub> O]

**4B Air Intake System (nonautomotive)**

	<b>4B3.9</b>	<b>4BT3.9</b>	<b>4BTA3.9</b>
Maximum Allowable Intake Restriction at Rated Speed and Loaded with Dirty Air Filter Element	508 mm H <sub>2</sub> O [20 in H <sub>2</sub> O]	635 mm H <sub>2</sub> O [25 in H <sub>2</sub> O]	635 mm H <sub>2</sub> O [25 in H <sub>2</sub> O]

**6B Air Intake System (nonautomotive)**

	<b>6B5.9</b>	<b>6BT5.9</b>	<b>6BTA5.9</b>
Maximum Allowable Intake Restriction at Rated Speed and Loaded with Dirty Air Filter Element	508 mm H <sub>2</sub> O [20 in H <sub>2</sub> O]	635 mm H <sub>2</sub> O [25 in H <sub>2</sub> O]	635 mm H <sub>2</sub> O [25 in H <sub>2</sub> O]

Refer to the following table for the control parts list (CPL), engine model, engine horsepower rating, and corresponding rated turbocharger boost pressure.

**Note:** Measurement of boost pressure is **not** a shortcut to logical troubleshooting. Low power can be caused by the fuel used, filter maintenance, and several engine components. Follow the logic charts for Engine Power Output Low, and measure boost pressure as indicated. Refer to this section, General Information, for measurement instructions.

These pressures are valid **only** at rated conditions (rated speed and power). Any attempt to use the values at engine speeds and loads other than those specified will result in an incorrect diagnosis.

**B Series Engines' Turbocharger Boost Pressure Specifications**

CPL	MODEL EN-GINE	hp @ rpm RATING	PEAK TORQUE ft-lb @ rpm	RATED BOOST (in Hg)			PEAK TORQUE BOOST (in Hg)		
				min	nom	max	min	nom	max
591	4B3.9	64 @ 2200	N/A	N/A	N/A	N/A	N/A	N/A	N/A
591	4B3.9	64 @ 2200	N/A	N/A	N/A	N/A	N/A	N/A	N/A
592	4BTA3.9	70 @ 2100	N/A	11	14	17	N/A	N/A	N/A
592	4BTA3.9	71 @ 2200	N/A	12	15	18	N/A	N/A	N/A
592	4BTA3.9	80 @ 2200	N/A	14	17	20	N/A	N/A	N/A
592	4BTA3.9	92 @ 2100	N/A	16	19	22	N/A	N/A	N/A
592	4BTA3.9	93 @ 2200	N/A	18	21	24	N/A	N/A	N/A
592	4BTA3.9	94 @ 2200	N/A	18	21	24	N/A	N/A	N/A
592	4BTA3.9	96 @ 2300	N/A	19	22	25	N/A	N/A	N/A
592	4BTA3.9	100 @ 2500	N/A	22	25	28	N/A	N/A	N/A
594	4BTA3.9	95 @ 2200	N/A	15	18	21	N/A	N/A	N/A
594	4BTA3.9	112 @ 2300	N/A	21	24	27	N/A	N/A	N/A
594	4BTA3.9	125 @ 2200	N/A	25	28	31	N/A	N/A	N/A
646	4BT3.9	71 @ 1500	N/A	9	12	15	N/A	N/A	N/A
646	4BT3.9	82 @ 1800	N/A	11	14	17	N/A	N/A	N/A
710	4BT3.9	75 @ 2200	N/A	13	16	19	N/A	N/A	N/A
710	4BT3.9	100 @ 2500	N/A	22	25	28	N/A	N/A	N/A
711	4BT3.9	71 @ 1500	N/A	9	12	15	N/A	N/A	N/A
711	4BT3.9	82 @ 1800	N/A	11	14	17	N/A	N/A	N/A
721	4B3.9	80 @ 2800	N/A	N/A	N/A	N/A	N/A	N/A	N/A
730	4BT3.9	85 @ 2500	235 @ 1200	17	20	23	9	10	11
730	4BT3.9	91 @ 2200	259 @ 1400	17	20	23	11	12	13
741	4BT3.9	130 @ 2500	N/A	18	21	24	N/A	N/A	N/A
741	4BT3.9	150 @ 2800	N/A	25	28	31	N/A	N/A	N/A
741	4BT3.9	150 @ 2800	N/A	25	28	31	N/A	N/A	N/A
762	4BT3.9	105 @ 2500	N/A	28	32	36	N/A	N/A	N/A
762	4BT3.9	105 @ 2800	N/A	31	35	39	N/A	N/A	N/A
763	4BT3.9	67 @ 2200	N/A	10	14	16	N/A	N/A	N/A
763	4BT3.9	71 @ 2200	N/A	10	14	16	N/A	N/A	N/A
767	4BT3.9	105 @ 2500	N/A	24	28	31	N/A	N/A	N/A
767	4BT3.9	105 @ 2800	N/A	27	30	33	N/A	N/A	N/A
826	4BT3.9	87 @ 1500	N/A	15	18	21	N/A	N/A	N/A
857	4BT3.9	120 @ 2500	N/A	40	44	48	N/A	N/A	N/A
858	4BT3.9	105 @ 2500	N/A	35	39	43	N/A	N/A	N/A
937	4BT3.9	74 @ 1500	N/A	10	13	16	N/A	N/A	N/A
971	4BT3.9	96 @ 2200	N/A	19	22	25	N/A	N/A	N/A
971	4BT3.9	100 @ 2500	N/A	22	25	28	N/A	N/A	N/A
986	4BTA3.9	120 @ 2500	N/A	28	31.0	34	17	19.4	21
1201	4BT3.9	80 @ 2500	N/A	19	22	25	N/A	N/A	N/A
1202	4BT3.9	74 @ 2500	N/A	18	21	24	N/A	N/A	N/A
1260	4BTA3.9	105 @ 2500	N/A	22	24.5	27	14	15.6	17
1268	4BT3.9	105 @ 2500	N/A	28	32	36	N/A	N/A	N/A
1520	4BTG2	104 @ 1800	N/A	19	21	23	N/A	N/A	N/A
1521	4BT3.9	74 @ 1500	N/A	3.4	6.4	9.4	N/A	N/A	N/A

CPL	MODEL EN-GINE	hp @ rpm RATING	PEAK TORQUE ft-lb @ rpm	RATED BOOST (in Hg)			PEAK TORQUE BOOST (in Hg)		
				min	nom	max	min	nom	max
1521	4BT3.9	86 @ 1800	N/A	5.8	8.8	12.0	N/A	N/A	N/A
1521	4BT3.9	88 @ 1800	N/A	19	21	23	N/A	N/A	N/A
1525	4BT3.9	72 @ 1500	N/A	N/A	N/A	N/A	N/A	N/A	N/A
1525	4BTG2	87 @ 1500	N/A	12	13	14	N/A	N/A	N/A
1963	4BTA3.9	116 @ 2500	295 @ 1500	36	39.3	42	23	25.6	29
1963	4BTA3.9	116 @ 2500	299 @ 1500	37	39.9	43	23	26	29
1963	4BTA3.9	125 @ 2200	350 @ 1500	37	40	43	29	32	35
1963	4BTA3.9	130 @ 2500	344 @ 1500	36	39	42	27	30	33
1965	4BT3.9	80 @ 2200	229 @ 1500	39	42	45	17	20	23
1965	4BT3.9	85 @ 2200	242 @ 1500	43	46	49	19	22	25
1965	4BTA3.9	85 @ 2200	254 @ 1500	43	46	49	19	22	25
1965	4BT3.9	90 @ 2200	269 @ 1500	45	49	53	22	26	30
1965	4BT3.9	92 @ 2100	293 @ 1500	46	49.3	52	28	31	34
1965	4BT3.9	92 @ 2100	295 @ 2100	45	49	53	25	29	33
1966	4BT3.9	92 @ 2000	302 @ 1300	31	33.7	37	20	22.7	26
1967	4BT3.9	85 @ 2500	239 @ 1500	38	41.5	45	16	20	24
1967	4BT3.9	90 @ 2500	254 @ 1500	38	42	45	20	24	28
1967	4BT3.9	95 @ 2200	285 @ 1500	38	42.2	45	24	27.9	32
1967	4BT3.9	100 @ 2200	298 @ 1500	41	44	47	27	30	33
1967	4BT3.9	105 @ 2100	293 @ 1500	39	42.3	45	26	29.2	32
1967	4BT3.9	105 @ 2400	280 @ 1500	41	44.3	47	23	26.6	31
1967	4BT3.9	110 @ 2500	293 @ 1500	42	44.8	48	25	29	33
2021	4BT3.9	93 @ 2200	353 @ 1550	N/A	N/A	N/A	N/A	N/A	N/A
2109	4BTA3.9	107 @ 2100	327 @ 1500	40	42.7	46	30	32.5	36
2109	4BTA3.9	107 @ 2100	334 @ 1500	39	42	45	30	33	36
2109	4BTA3.9	107 @ 2100	328 @ 1600	40	42.7	46	30	32.5	36
2109	4BTA3.9	110 @ 2200	328 @ 1500	39	42	45	30	33	36
2109	4BTA3.9	110 @ 2200	328 @ 1500	39	42.0	45	30	33	36
2109	4BTA3.9	110 @ 2200	333 @ 1500	39	41.7	45	30	33.3	36
2109	4BTA3.9	116 @ 2500	300 @ 1500	39	42	45	29	32	35
2109	4BTA3.9	116 @ 2500	312 @ 1500	40	43	46	29	32	35
2264	4BTA3.9	125 @ 2200	355 @ 1500	36	39	42	29	32	35
2302	4BT3.9	110 @ 2500	278 @ 1500	41	43.7	47	24	26.6	30
2302	4BT3.9	110 @ 2500	278 @ 1500	40	43	46	23	26	29
2302	4BT3.9	110 @ 2500	293 @ 1500	41	43.7	47	26	28.6	32
2351	4BTA3.9	110 @ 2200	328 @ 1500	37	39.9	43	27	29.5	33
2359	4BT3.9	85 @ 2500	239 @ 1500	39	41.5	45	17	20	23
2361	4B3.9	74 @ 2500	201 @ 1200	N/A	N/A	N/A	N/A	N/A	N/A
2361	4B3.9	80 @ 2500	201 @ 1200	N/A	N/A	N/A	N/A	N/A	N/A
2361	4B3.9	80 @ 2500	201 @ 1200	N/A	N/A	N/A	N/A	N/A	N/A
2374	4B3.9	75 @ 2200	201 @ 1200	N/A	N/A	N/A	N/A	N/A	N/A
2478	4BT3.9	80 @ 2200	229 @ 1500	39	41.8	45	17	20	23
2486	4B3.9	75 @ 2200	201 @ 1200	N/A	N/A	N/A	N/A	N/A	N/A
2488	4B3.9	54 @ 2000	179 @ 1200	N/A	N/A	N/A	N/A	N/A	N/A
2489	4B3.9	60 @ 2200	179 @ 1200	N/A	N/A	N/A	N/A	N/A	N/A
2490	4B3.9	67 @ 2200	192 @ 1200	N/A	N/A	N/A	N/A	N/A	N/A
2599	4B3.9	75 @ 2200	193 @ 1200	N/A	N/A	N/A	N/A	N/A	N/A
2599	4B3.9	80 @ 2500	193 @ 1200	N/A	N/A	N/A	N/A	N/A	N/A
2601	4B3.9	60 @ 2000	180 @ 1200	N/A	N/A	N/A	N/A	N/A	N/A
2601	4 B3.9	60 @ 2000	190 @ 1200	N/A	N/A	N/A	N/A	N/A	N/A
2808	4BT3.9	110 @ 2500	293 @ 1500	41	43.7	47	24	26.6	30
596	6B5.9	93 @ 2200	262 @ 1100	N/A	N/A	N/A	N/A	N/A	N/A
598	6BT5.9	160 @ 2500	N/A	28	32	36	N/A	N/A	N/A
598	6BT5.9	160 @ 2800	N/A	31	35	39	N/A	N/A	N/A
600	6BTA5.9	180 @ 2500	N/A	39	43	47	N/A	N/A	N/A

CPL	MODEL EN-GINE	hp @ rpm RATING	PEAK TORQUE ft-lb @ rpm	RATED BOOST (in Hg)			PEAK TORQUE BOOST (in Hg)		
				min	nom	max	min	nom	max
692	6BT5.9	160 @ 2500	N/A	30	34	38	N/A	N/A	N/A
692	6BT5.9	160 @ 2600	N/A	31	35	39	N/A	N/A	N/A
697	6BT5.9	113 @ 1500	N/A	15	19	21	N/A	N/A	N/A
697	6BT5.9	134 @ 1800	N/A	21	24	27	N/A	N/A	N/A
713	6BT5.9	113 @ 1500	N/A	12	18	21	N/A	N/A	N/A
713	6BT5.9	134 @ 1800	N/A	21	24	27	N/A	N/A	N/A
715	6BTA5.9	143 @ 2100	N/A	26	29	32	N/A	N/A	N/A
716	6BT5.9	156 @ 2500	N/A	45	49	53	N/A	N/A	N/A
728	6BT5.9	128 @ 2800	N/A	19	22	25	N/A	N/A	N/A
728	6BT5.9	130 @ 2650	N/A	19	22	25	N/A	N/A	N/A
729	6BT5.9	134 @ 2200	N/A	23	26	29	N/A	N/A	N/A
742	6BT5.9	152 @ 2500	N/A	30	33	36	N/A	N/A	N/A
742	6BT5.9	180 @ 2500	N/A	39	43	47	N/A	N/A	N/A
742	6BT5.9	210 @ 2600	N/A	47	51	55	N/A	N/A	N/A
766	6BT5.9	160 @ 2500	N/A	28	32	36	N/A	N/A	N/A
766	6BT5.9	160 @ 2800	N/A	31	35	39	N/A	N/A	N/A
791	6B5.9	120 @ 2800	N/A	N/A	N/A	N/A	N/A	N/A	N/A
791	6B5.9	120 @ 2800	N/A	N/A	N/A	N/A	N/A	N/A	N/A
804	6BT5.9	145 @ 2600	N/A	39	43	47	N/A	N/A	N/A
804	6BT5.9	160 @ 2500	N/A	38	41	44	N/A	N/A	N/A
807	6BT5.9	99 @ 2200	N/A	13	16	19	N/A	N/A	N/A
834	6BTA5.9	180 @ 2500	N/A	32	36	40	N/A	N/A	N/A
856	6BTA5.9	180 @ 2500	N/A	46	50	54	N/A	N/A	N/A
912	6BTA5.9	190 @ 2600	N/A	34	38	42	N/A	N/A	N/A
938	6BT5.9	135 @ 2200	442 @ 1400	23	25	28	19	21	23
938	6BT5.9	137 @ 2200	393 @ 1600	18	21	24	16	18	20
938	6BT5.9	140 @ 2200	426 @ 1300	24	27	30	15	17	19
938	6BT5.9	145 @ 2200	425 @ 1500	25	28	31	19	21	23
938	6BT5.9	87 @ 2200	265 @ 1200	10	13	16	5	6	7
938	6BT5.9	97 @ 2200	270 @ 1200	13	16	19	6	7	8
943	6BT5.9	120 @ 2100	N/A	18	21	24	N/A	N/A	N/A
947	6BT5.9	145 @ 2600	N/A	24	27	30	N/A	N/A	N/A
947	6BT5.9	160 @ 2500	N/A	29	33	37	N/A	N/A	N/A
947	6BT5.9	160 @ 2600	N/A	31	35	39	N/A	N/A	N/A
947	6BT5.9	130 @ 2500	N/A	20	23	26	N/A	N/A	N/A
948	6BT5.9	145 @ 2600	N/A	24	27	30	N/A	N/A	N/A
949	6BT5.9	88 @ 2000	N/A	10	13	16	N/A	N/A	N/A
949	6BT5.9	121 @ 2200	N/A	14	17	20	N/A	N/A	N/A
949	6BT5.9	124 @ 2400	N/A	21	24	27	N/A	N/A	N/A
949	6BT5.9	126 @ 2100	N/A	19	22	25	N/A	N/A	N/A
949	6BT5.9	130 @ 2500	N/A	23	26	29	N/A	N/A	N/A
949	6BT5.9	140 @ 2200	N/A	24	27	30	N/A	N/A	N/A
949	6BT5.9	142 @ 2100	N/A	24	24	30	N/A	N/A	N/A
949	6BT5.9	145 @ 2200	N/A	25	28	31	N/A	N/A	N/A
949	6BT5.9	148 @ 2300	N/A	27	30	33	N/A	N/A	N/A
949	6BT5.9	152 @ 2500	N/A	28	32	36	N/A	N/A	N/A
950	6BT5.9	120 @ 2100	N/A	18	21	24	N/A	N/A	N/A
953	6BTA5.9	220 @ 2500	N/A	23	26	29	N/A	N/A	N/A
953	6BTA5.9	250 @ 2600	N/A	44	48	52	N/A	N/A	N/A
961	6BT5.9	115 @ 1500	N/A	16	19	22	N/A	N/A	N/A
961	6BT5.9	135 @ 1800	N/A	22	25	28	N/A	N/A	N/A
970	6BTA-M2	250 @ 2600	N/A	32	36	40	N/A	N/A	N/A
970	6BTA-M2	300 @ 2800	N/A	46	50	54	N/A	N/A	N/A
970	6BTSWA	300 @ 2800	N/A	40	44	48	N/A	N/A	N/A
983	6BTA5.9	157 @ 2500	N/A	35	39	43	N/A	N/A	N/A
983	6BTA5.9	177 @ 2500	N/A	38	42	46	N/A	N/A	N/A

CPL	MODEL EN-GINE	hp @ rpm RATING	PEAK TORQUE ft-lb @ rpm	RATED BOOST (in Hg)			PEAK TORQUE BOOST (in Hg)		
				min	nom	max	min	nom	max
998	6BTA5.9	200 @ 2500	N/A	45	49	53	N/A	N/A	N/A
1160	6BT5.9	160 @ 2500	N/A	29	33	37	N/A	N/A	N/A
1165	6BTA5.9	227 @ 1760	N/A	37	41	45	N/A	N/A	N/A
1165	6BTA5.9	255 @ 2100	N/A	46	50	54	N/A	N/A	N/A
1168	6BT5.9	148 @ 2300	N/A	25	28	31	N/A	N/A	N/A
1168	6BT5.9	152 @ 2500	N/A	27	31	35	N/A	N/A	N/A
1209	6BTA5.9	176 @ 2300	N/A	30	33	36	N/A	N/A	N/A
1266	6BT5.9	142 @ 2500	N/A	27	31	35	N/A	N/A	N/A
1279	6BT5.9	125 @ 2200	412 @ 1400	18	20	22	14	16	18
1322	6BTA-M1	220 @ 2500	N/A	32	36	40	N/A	N/A	N/A
1322	6BTA5.9	250 @ 2600	N/A	34	38	42	N/A	N/A	N/A
1322	6BTA-M1	250 @ 2600	N/A	42	46	50	N/A	N/A	N/A
1419	6BT5.9	250 @ 2500	N/A	38	42	46	N/A	N/A	N/A
1518	6BT5.9	169 @ 1800	N/A	32	35	39	N/A	N/A	N/A
1549	6BTA5.9	160 @ 2500	400 @ 1600	30	34	38	23	25	28
1552	6BTA5.9	210 @ 2500	485 @ 1600	44	47.7	52	29	31.9	35
1570	6BTJWA	250 @ 2600	N/A	35	39	43	N/A	N/A	N/A
1579	6BTA5.9	160 @ 2500	400 @ 1600	31	35.4	39	14	17.2	20
1613	6BT5.9	250 @ 2600	N/A	36	40	44	N/A	N/A	N/A
1640	6BTA5.9	185 @ 2200	531 @ 1500	41	45	50	27	30	33
1863	6BTAA	180 @ 2500	42 @ 1500	36	39	42	22	25	28
1889	6BTA5.9	185 @ 2400	550 @ 1500	43	46	49	30	33	36
1889	6BTA5.9	200 @ 2500	550 @ 1500	48	51	54	30	33	36
1914	6BTA5.9	190 @ 2300	475 @ 1600	44	48	52	22	26	30
1945	6BT5.9	200 @ 2200	583 @ 1500	41	46	51	31	34	37
1945	6BTA5.9	200 @ 2500	581 @ 1500	41	46	51	30	33	36
1948	6BT5.9	148 @ 2200	440 @ 1600	38	41	44	25	28	31
1948	6BT5.9	148 @ 2200	440 @ 1600	37	40	43	43	24	37
1948	6BT5.9	152 @ 2500	414 @ 1600	40	43	46	24	27	30
1948	6BT5.9	155 @ 2100	449 @ 1600	39	41.8	45	24	27	30
1959	6BTA5.9	160 @ 2500	400 @ 1600	30	34	38	18	21	24
1962	6BTA5.9	147 @ 2000	428 @ 1500	33	36	39	21	24	27
1962	6BTA5.9	150 @ 2200	466 @ 1500	35	38	41	23	26	29
1962	6BTA5.9	150 @ 2200	466 @ 1500	35	38	41	23	26	29
1962	6BTA5.9	150 @ 2200	483 @ 1500	35	38.4	41	26	28.6	32
1962	6BTA5.9	160 @ 2000	462 @ 1500	38	41	44	23	26	29
1962	6BTA5.9	166 @ 2075	474 @ 1500	42	44.6	48	25	28.1	31
1962	6BTA5.9	167 @ 2000	480 @ 1500	36	39	42	24	27	30
1962	6BTA5.9	150 @ 2200	483 @ 1500	35	38	41	26	29	32
1962	6BTA5.9	153 @ 2200	485 @ 1500	37	40	43	24	27	30
1962	6BTA5.9	165 @ 2200	512 @ 1500	42	45	48	28	31	34
1962	6BTA5.9	165 @ 2200	532 @ 1500	42	44.6	48	29	31.6	35
1962	6BTA5.9	168 @ 2200	541 @ 1500	37	40	43	24	27	30
1962	6BTA5.9	167 @ 2000	479 @ 1500	40	43	46	25	28	31
1962	6BTA5.9	170 @ 2300	475 @ 1500	42	45	48	23	26	29
1962	6BTA5.9	169 @ 2100	480 @ 1500	41	44	47	25	28	31
1962	6BTA5.9	169 @ 2100	480 @ 1500	41	44	47	25	28	31
1968	6BTAA	160 @ 2500	400 @ 1600	30	34	38	19	22	25
1975	6BTA5.9	330 @ 2800	687 @ 2000	52	57	62	37	41	45
1989	6BTA5.9	185 @ 2500	553 @ 1500	47	51	55	33	37	41
2016	6BTAA5.9	129 @ 2500	347 @ 1500	25	29.2	33	11	13.9	17
2017	6BTA5.9	178 @ 2500	474 @ 1500	34	36.6	40	19	21.6	25
2023	6BTAA	21 @ 2600	440 @ 1600	48	51	54	23	26	29
2035	6BTA5.9	195 @ 2800	420 @ 1600	32	35	38	25	28.5	31
2063	6BTA5.9	185 @ 2300	580 @ 1500	40	43	46	33	36	39
2063	6BTA5.9	185 @ 2400	558 @ 1500	46	48.7	52	30	33.1	36



CPL	MODEL EN-GINE	hp @ rpm RATING	PEAK TORQUE ft-lb @ rpm	RATED BOOST (in Hg)			PEAK TORQUE BOOST (in Hg)		
				min	nom	max	min	nom	max
2063	6BTA5.9	185 @ 2200	566 @ 1500	40	43	46	33	36	39
2063	6BTA5.9	174 @ 2200	590 @ 1500	45	48	51	36	39	42
2071	6BT5.9	97 @ 2200	267 @ 1700	21	24	27	13	16	19
2071	6BT5.9	97 @ 2200	270 @ 1700	20	24	28	12	16	20
2071	6BT5.9	101 @ 2200	313 @ 1500	23	26	29	11	14	17
2071	6BT5.9	118 @ 2400	327 @ 1600	35	38	41	16	19	22
2071	6BT5.9	110 @ 1900	341 @ 1600	27	30	33	17	20	23
2071	6BT5.9	110 @ 2200	341 @ 1600	28	31	34	18	21	24
2071	6BT5.9	120 @ 2200	372 @ 1500	32	35	38	22	25	28
2071	6BT5.9	126 @ 2100	380 @ 1600	29	32	35	19	22	25
2071	6BT5.9	130 @ 2200	388 @ 1600	33	36	39	20	23	26
2071	6BT5.9	130 @ 2500	368 @ 1600	42	44.9	48	18	21	24
2071	6BT5.9	135 @ 2100	404 @ 1600	30	33	36	19	22	25
2071	6BT5.9	135 @ 2200	419 @ 1500	32	35	38	19	22	25
2071	6BT5.9	135 @ 2200	419 @ 1600	35	38	41	23	26	29
2071	6BT5.9	135 @ 2400	379 @ 1600	42	45	48	21	24	27
2071	6BT5.9	135 @ 2200	419 @ 1600	37	40	43	25	28	31
2071	6BT5.9	135 @ 2100	419 @ 1500	30	33	36	19	22	25
2071	6BT5.9	140 @ 2000	416 @ 1600	32	35	38	23	26	29
2071	6BT5.9	145 @ 2100	438 @ 1500	38.4	41.4	44.4	40	42.1	44
2071	6BT5.9	137 @ 2000	440 @ 1600	32	35.1	38	28	31	34
2072	6BTA5.9	174 @ 2500	458 @ 1500	43	46.1	49	24	27.2	30
2072	6BTA5.9	174 @ 2500	470 @ 1500	42	45	48	24	27	30
2174	6BTAA5.9	180 @ 2500	420 @ 1500	36	39	42	22	25	28
2175	6BTAA5.9	215 @ 2600	440 @ 1600	48	51	54	23	26	29
2122	6BTA5.9	177 @ 2500	480 @ 1500	N/A	N/A	N/A	N/A	N/A	N/A
2208	6BTA	370 @ 3000	726 @ 2200	56	59	62	40	43	46
2249	6BTAA5.9	232 @ 2500	590 @ 1500	50	52.6	56	30	32.5	36
2292	6BTA5.9	147 @ 2000	438 @ 1500	35	38	41	23	26	29
2292	6BTA5.9	160 @ 1900	479 @ 1500	38	41	44	23	26	29
2292	6BTA5.9	169 @ 2100	480 @ 1500	41	44	47	25	28	31
2292	6BTA5.9	169 @ 2100	485 @ 1500	41	44	47	23	26	29
2292	6BTA5.9	169 @ 2100	485 @ 1500	45	47.5	51	29	31.6	35
2292	6BTA5.9	167 @ 2000	480 @ 1500	37	39.6	43	25	27.5	31
2308	6BTAA5.9	180 @ 2500	420 @ 1500	36	39	42	22	25	28
2479	6BTA5.9	174 @ 2200	590 @ 1500	46	48.4	51	37	39.9	43
2530	6BT5.9	135 @ 1800	N/A	30	32.5	35	N/A	N/A	N/A
2530	6BT5.9	143 @ 1800	N/A	29	31.9	35	N/A	N/A	N/A
2530	6BT5.9	170 @ 1800	N/A	20	21.8	23	N/A	N/A	N/A

**Exhaust System**

**Exhaust System Data (automotive)**

	<b>B3.9</b>	<b>B5.9</b>
Maximum Allowable Exhaust Restriction at Rated Speed and Loaded (1991 EPA certified)	114.3 mm Hg [4.5 in Hg]	114.3 mm Hg [4.5 in Hg]
Maximum Allowable Exhaust Restriction at Rated Speed and Loaded (1994 EPA certified)	152.4 mm Hg [6 in Hg] with oxidation catalyst	152.4 mm Hg [6 in Hg] with oxidation catalyst

**4B Exhaust System Data (nonautomotive)**

<b>EXHAUST SYSTEM</b>	<b>4B3.9</b>	<b>4BT3.9</b>	<b>4BTA3.9</b>
Maximum Allowable Exhaust Restriction at Rated Speed and Loaded	76.2 mm Hg [3.0 in Hg]	76.2 mm Hg [3.0 in Hg]	76.2 mm Hg [3.0 in Hg]

**6B Exhaust System Data (nonautomotive)**

<b>EXHAUST SYSTEM</b>	<b>6B5.9</b>	<b>6BT5.9</b>	<b>6BTA5.9</b>
Maximum Allowable Exhaust Restriction at Rated Speed and Loaded	76.2 mm Hg [3.0 in Hg]	76.2 mm Hg [3.0 in Hg]	76.2 mm Hg [3.0 in Hg]

**Compressed Air System**

**A/C Model SS191 Specifications**

Compressor Swept Volume at 1250 rpm .....	4.0 L/sec [8.5 SCFM]
Piston Displacement .....	191 cc [11.65 C.I.D.]
Bore .....	80 mm [3.15 in]
Stroke .....	38.1 mm [1.50 in]
Speed .....	1.135 x Engine rpm
Cooling .....	Engine Coolant
Lubrication .....	Engine Lubricating Oil
Plumbing Line Sizes:	
Coolant Inlet and Outlet (pipe fitting) .....	1/2-in NPTF [0.50 in]
Air Inlet (inside diameter) .....	19-mm [0.75-in] Nipple
Air Outlet (minimum inside diameter) .....	1/2-in NPTF [0.50 in]
Height, Overall (approximate) .....	289 mm [11.4 in]
Width, Overall (approximate) .....	125 mm [4.9 in]
Length, Overall (approximate) .....	186 mm [7.32 in]
Weight (approximate) .....	13.6 kg [30 lb]

**A/C Model QE296 Specifications**

Compressor Swept Volume at 1250 rpm .....	6.2 L/sec [13.2 SCFM]
Piston Displacement .....	296 cc [18.06 C.I.D.]
Bore .....	92.08 mm [3.625 in]
Stroke .....	44.45 mm [1.750 in]
Speed .....	1.135 x Engine rpm
Cooling .....	Engine Coolant
Lubrication .....	Engine Lubricating Oil
Plumbing Line Sizes:	
Coolant Inlet and Outlet (pipe fitting) .....	1/2-in NPTF [0.50 in]
Air Inlet (inside diameter) .....	19-mm [0.75-in] Nipple
Air Outlet (minimum inside diameter) .....	1/2-in NPTF [0.50 in]
Height, Overall (approximate) .....	305 mm [12 in]
Width, Overall (approximate) .....	159 mm [6.25 in]
Length, Overall (approximate) .....	267 mm [10.5 in]
Weight (approximate) .....	20 kg [44 lb]

**A/C Model QE338 Specifications**

Compressor Swept Volume at 1250 rpm .....	7.1 L/sec [15 SCFM]
Piston Displacement .....	338 cc [20.6 C.I.D.]
Bore .....	98.43 mm [3.875 in]
Stroke .....	44.45 mm [1.750 in]
Speed .....	1.135 x Engine rpm
Cooling .....	Engine Coolant
Lubrication .....	Engine Lubricating Oil
Plumbing Line Sizes:	
Coolant Inlet and Outlet (pipe fitting) .....	1/2-in NPTF [0.50 in]

**B3.9 and B5.9 Series Engines  
Section V - Specifications**

Air Inlet (inside diameter) .....	19-mm [0.75-in] Nipple
Air Outlet (minimum inside diameter) .....	1/2-in NPTF [0.50 in]
Height, Overall (approximate) .....	305 mm [12 in]
Width, Overall (approximate) .....	159 mm [6.25 in]
Length, Overall (approximate) .....	267 mm [10.5 in]
Weight (approximate) .....	18 kg [40 lb]

**A/C Model HD650 Specifications**

Compressor Swept Volume at 1250 rpm .....	6.2 L/sec [13.2 SCFM]
Piston Displacement .....	296 cc [18.06 C.I.D.]
Bore .....	92.08 mm [3.625 in]
Stroke .....	44.45 mm [1.750 in]
Speed .....	1.135 x Engine rpm
Cooling .....	Engine Coolant
Lubrication .....	Engine Lubricating Oil
Plumbing Line Sizes:	
Coolant Inlet and Outlet (pipe fitting) .....	1/2-in NPTF [0.50 in]
Air Inlet (inside diameter) .....	19-mm [0.75-in] Nipple
Air Outlet (minimum inside diameter) .....	1/2-in NPTF [0.50 in]
Height, Overall (approximate) .....	305 mm [12 in]
Width, Overall (approximate) .....	159 mm [6.25 in]
Length, Overall (approximate) .....	267 mm [10.5 in]
Weight (approximate) .....	20 kg [44 lb]

**A/C Model HD850 Specifications**

Compressor Swept Volume at 1250 rpm .....	7.1 L/sec [15 SCFM]
Piston Displacement .....	338 cc [20.6 C.I.D.]
Bore .....	98.43 mm [3.875 in]
Stroke .....	44.45 mm [1.750 in]
Speed .....	1.135 x Engine rpm
Cooling .....	Engine Coolant
Lubrication .....	Engine Lubricating Oil
Plumbing Line Sizes:	
Coolant Inlet and Outlet (pipe fitting) .....	1/2-in NPTF [0.50 in]
Air Inlet (inside diameter) .....	19-mm [0.75-in] Nipple
Air Outlet (minimum inside diameter) .....	1/2-in NPTF [0.50 in]
Height, Overall (approximate) .....	305 mm [12 in]
Width, Overall (approximate) .....	159 mm [6.25 in]
Length, Overall (approximate) .....	267 mm [10.5 in]
Weight (approximate) .....	18 kg [40 lb]

**Electrical System**

**Electrical System Data (automotive)**

	<b>B3.9</b>	<b>B5.9</b>
<b>Minimum Recommended Battery Capacity @ -18°C [0°F]</b>		
<b>With Light Accessories*</b>		
12-VDC Starter	625CCA	800CCA
24-VDC Starter	400CCA	400CCA
<b>With Heavy Accessories**</b>		
12-VDC Starter	800CCA	950CCA
24-VDC Starter	400CCA	475CCA
<b>Maximum Allowable Resistance of Starting Circuit</b>		
With 12-VDC Starter - Ohms	0.0012	0.0012
With 24-VDC Starter - Ohms	0.0020	0.0020

\*Typical light accessories include alternator, small steering pump, and disengaged clutch.

\*\*Typical heavy accessories include hydraulic pump and torque converter.

4B Electrical System Data (nonautomotive)

	4B3.9	4BT3.9	4BTA3.9
<b>Minimum Recommended Battery Capacity @ -18°C [0°F]</b>			
<b>With Light Accessories*</b>			
12-VDC Starter	625CCA	625CCA	625CCA
24-VDC Starter	312CCA	400CCA	400CCA
<b>With Heavy Accessories**</b>			
12-VDC Starter	800CCA	800CCA	800CCA
24-VDC Starter	400CCA	400CCA	400CCA
<b>Maximum Allowable Resistance of Starting Circuit</b>			
With 12-VDC Starter - Ohms	0.0012	0.0012	0.0012
With 24-VDC Starter - Ohms	0.0020	0.0020	0.0020

\* Typical light accessories include alternator, small steering pump, and disengaged clutch.

\*\* Typical heavy accessories include hydraulic pump and torque converter.

6B Electrical System Data (nonautomotive)

	6B5.9	6BT5.9	6BTA5.9
<b>Minimum Recommended Battery Capacity @ -18°C [0°F]</b>			
<b>With Light Accessories*</b>			
12-VDC Starter	800CCA	800CCA	800CCA
24-VDC Starter	400CCA	400CCA	400CCA
<b>With Heavy Accessories**</b>			
12-VDC Starter	950CCA	950CCA	950CCA
24-VDC Starter	475CCA	475CCA	475CCA
<b>Maximum Allowable Resistance of Starting Circuit</b>			
With 12-VDC Starter - Ohms	0.0012	0.0012	0.0012
With 24-VDC Starter - Ohms	0.0020	0.0020	0.0020

\* Typical light accessories include alternator, small steering pump, and disengaged clutch.

\*\* Typical heavy accessories include hydraulic pump and torque converter.

**Engine Testing**

Maintain the following limits (see note) during a chassis dynamometer test:

Intake Restriction (maximum)

Clean Filter:

Light-Duty .....	254 mm H <sub>2</sub> O [10 in H <sub>2</sub> O]
Medium-Duty .....	305 mm H <sub>2</sub> O [12 in H <sub>2</sub> O]
Heavy-Duty .....	381 mm H <sub>2</sub> O [15 in H <sub>2</sub> O]

Dirty Filter:

Light-Duty .....	635 mm [25 in]
Medium-Duty .....	635 mm [25 in]
Heavy-Duty .....	635 mm [25 in]

Exhaust Back Pressure (maximum) Nonautomotive ..... 76 mm Hg [3.0 in Hg]

Exhaust Back Pressure (maximum) Automotive with Catalyst .. 152 mm Hg [6.0 in Hg] to 127 mm Hg [5.0 in Hg]

Back Pressure (maximum) Automotive without Catalyst ..... 114 mm Hg [4.5 in Hg] to 102 mm Hg [4.0 in Hg]

Oil Pressure:

Low Idle (minimum allowable) .....	69 kPa [10 psi]
Rated Speed (minimum allowable) .....	207 kPa [30 psi]

Fuel Inlet Restriction (maximum) ..... 100 mm Hg [4 in Hg]

Fuel Return Restriction (maximum) ..... 518 mm Hg [20.4 in Hg]

**Note:** Due to variations in ratings of different engine models, refer to the specific engine data sheet for the particular engine model being tested.

**Batteries (Specific Gravity)**

Specific Gravity at 27°C [80°F]	State of Charge
1.260 to 1.280	100%
1.230 to 1.250	75%
1.200 to 1.220	50%
1.170 to 1.190	25%
1.110 to 1.130	Discharged

**Battery Cable Specifications**

Cable Size Gauge	Nominal Resistance in Ohms		Maximum Total Length (sum of both cables)			
	Per Meter	Per Foot	12 VDC		24 VDC	
			Meter	Feet	Meter	Feet
4	0.000984	0.00030	NR*	NR*	2.03	6.7
2	0.000615	0.000188	1.63	5.3	3.26	10.6
1	0.000492	0.000150	2.03	6.7	4.06	13.4
0	0.000386	0.000118	2.59	8.5	5.18	17.0
00	0.000292	0.000090	3.43	11.3	6.86	22.6
000	0.000232	0.000071	4.32	14.2	8.64	28.4

\* Not recommended



Wiring Size Recommendations - Starter and Fuel Solenoid

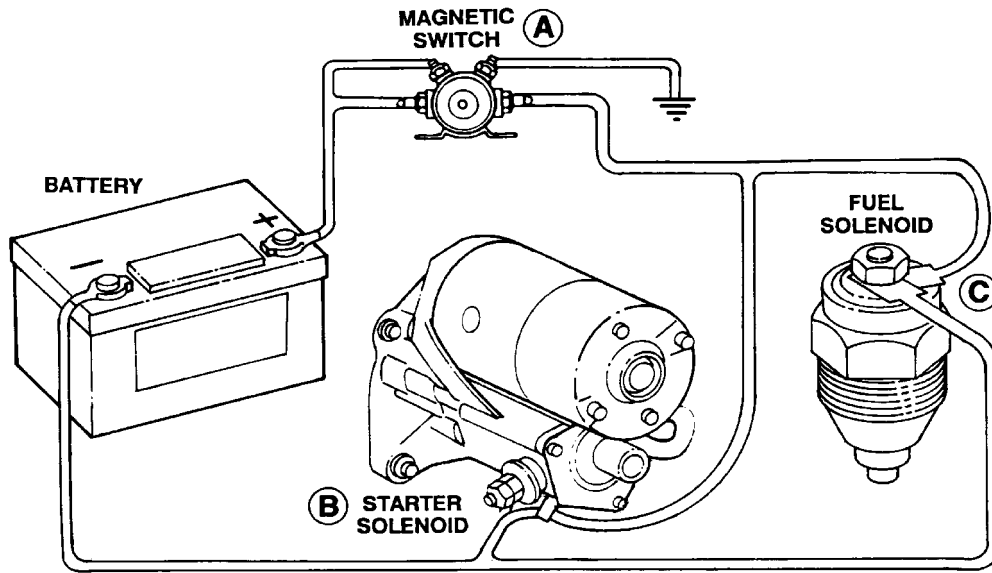

ea900gc

Recommended Wire Gauge Table (Values in table are AWG. size for 12/24-VDC systems)			
Wire Length in Circuit	Battery to A	A to B	A to C
0.91 m [3 ft]	10/14	12/14	14/16
1.21 m [4 ft]	10/12	10/14	14/16
1.52 m [5 ft]	8/10	10/12	14/16
2.74 m [9 ft]	6/8	8/10	12/14
5.49 m [18 ft]	4/6	6/8	8/10

Wire length in circuit means total length in each individual circuit, e.g., Battery to A equals one circuit.

For example, in a 12-VDC circuit:

Battery to A = 1.52 m [5 ft]; gauge required = 8 gauge

A to B = 1.52 m [5 ft]; gauge required = 10 gauge

A to C = 2.74 m [9 ft]; gauge required = 12 gauge.

If the system is double-pole wiring (no frame ground), then the fuel and starter solenoid circuit lengths would include the return cable run to the battery negative (-) post.

### Drive Belt Tension

SAE Belt Size	Belt Tension Gauge Part No.		Belt Tension New		Belt Tension Range Used*	
	Click-type	Burroughs	N	lbf	N	lbf
0.380 in	3822524		620	140	270 to 490	60 to 110
0.440 in	3822524		620	140	270 to 490	60 to 110
1/2 in	3822524	ST-1138	620	140	270 to 490	60 to 110
11/16 in	3822524	ST-1138	620	140	270 to 490	60 to 110
3/4 in	3822524	ST-1138	620	140	270 to 490	60 to 110
7/8 in	3822524	ST-1138	620	140	270 to 490	60 to 110
4 rib	3822524	ST-1138	620	140	270 to 490	60 to 110
5 rib	3822524	ST-1138	670	150	270 to 530	60 to 120
6 rib	3822525	ST-1293	710	160	290 to 580	65 to 130
8 rib	3822525	ST-1293	890	200	360 to 710	80 to 160
10 rib	3822525	3823138	1110	250	440 to 890	100 to 200
12 rib	3822525	3823138	1330	300	530 to 1070	120 to 240
12 rib K section	3822525	3823138	1330	300	890 to 1070	200 to 240

**Note:** This chart does not apply to automatic belt tensioners.

- \* A belt is considered used if it has been in service for ten minutes or longer.
- \* If used belt tension is less than the minimum value, tighten the belt to the maximum used belt value.

### Engine Component Torque Values

Component	Wrench Size	Torque Value		
		N•m	ft-lb	in-lb
Aftercooler Mounting	10 mm	24	18	
Aftercooler Water Hose Clamp	8 mm	5		44
Alternator Link (Delco 10-15 SI)	13 mm	24	18	
Alternator Link (Delco 20-27 SI)	3/4 in	43	32	
Alternator Mtg. Bolt 10-15 SI	15 mm	43	32	
Alternator Mtg. 27 SI	18 mm	77	57	
Alternator Support (Upper)	10 mm	24	18	
Belt Tensioner Flat Bracket	Allen 5 mm	24	18	
Belt Tensioner Mounting	15 mm	43	32	
Crankshaft Damper and Pulley	15 mm	137	101	
Crossover Clamp	5/16 in	5		44
Tee Bolt Type Clamp	11 mm	8		71
Exhaust Outlet Pipe, V Band Clamp	7/16 in	8		71
Fan Bracket Mounting	10 mm	24	18	
Fan Pulley	10 mm	24	18	
Fan Pulley	13 mm	43	32	

Component	Wrench Size	Torque Value		
		N•m	ft-lb	in-lb
Fuel Filter	75 to 85 mm	Install as specified by filter manufacturer		
Fuel Filter Adapter Nut	24 mm	32	24	
Lubricating Oil Filter	75 to 85 mm	3/4 Turn after Contact		
Lubricating Oil Cooler Assembly	10 mm	24	18	
Lubricating Oil Pan Drain Plug (steel)	17 mm	80	59	
Lubricating Oil Pan Drain Plug (aluminum)	17 mm	55	41	
Lubricating Oil Pan Heater Plug	27 mm	80	59	
Lubricating Oil Pressure Regulator Plug	19 mm	80	59	
Starter Mounting	10 mm	43	32	
Thermostat Housing	10 mm	24	18	
Water Inlet Connection	15 mm	43	32	
Water Pump Mounting	13 mm	24	18	
Valve Cover	15 mm	12		106
Water-in-Fuel Sensor	19 mm	Hand-Tighten		
Top - Load Filter Lid	10 mm	Hand-Tighten		

## Capscrew Markings and Torque Values

### ⚠ CAUTION ⚠

When replacing capscrews, always use a capscrew of the same measurement and strength as the capscrew being replaced. Using the wrong capscrews can result in engine damage.

Metric capscrews and nuts are identified by the grade number stamped on the head of the capscrew or on the surface of the nuts. U.S. Customary capscrews are identified by radial lines stamped on the head of the capscrew.

The following examples indicate how capscrews are identified:

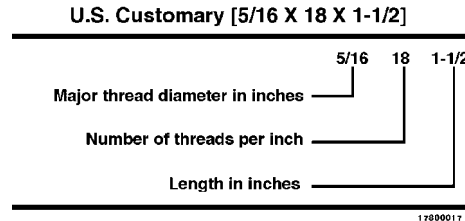
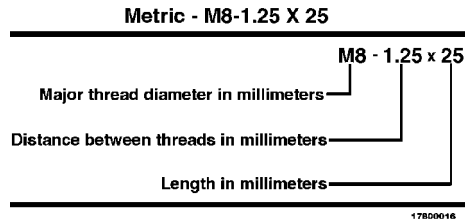

**NOTES:**

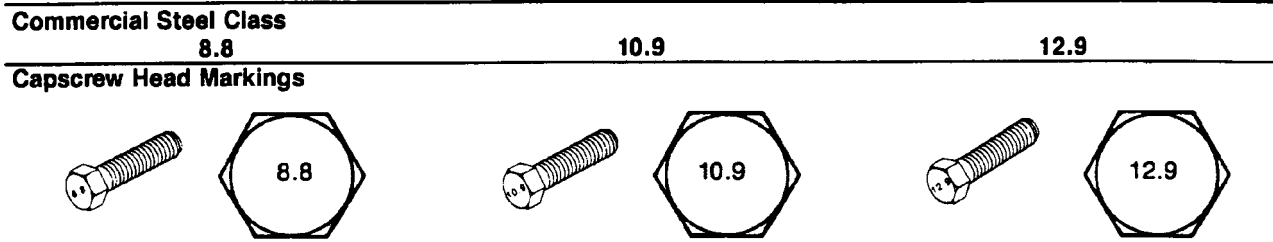

1. **Always** use the torque values listed in the following tables when specific torque values are **not** available.
2. Do **not** use the torque values in place of those specified in other sections of this manual.
3. The torque values in the table are based on the use of lubricated threads.
4. When the ft-lb value is less than 10, convert the ft-lb value to in-lb to obtain a better torque with an in-lb torque wrench. Example: 6 ft-lb equals 72 in-lb.

Capscrew Markings and Torque Values - Metric



Body Size Diameter mm	Torque				Torque				Torque			
	Cast Iron		Aluminum		Cast Iron		Aluminum		Cast Iron		Aluminum	
	N•m	ft-lb	N•m	ft-lb	N•m	ft-lb	N•m	ft-lb	N•m	ft-lb	N•m	ft-lb
6	9	5	7	4	13	10	7	4	14	9	7	4
7	14	9	11	7	18	14	11	7	23	18	11	7
8	23	17	18	14	33	25	18	14	40	29	18	14
10	45	33	30	25	65	50	30	25	70	50	30	25
12	80	60	55	40	115	85	55	40	125	95	55	40
14	125	90	90	65	180	133	90	65	195	145	90	65
16	195	140	140	100	280	200	140	100	290	210	140	100
18	280	200	180	135	390	285	180	135	400	290	180	135
20	400	290	—	—	550	400	—	—	—	—	—	—

Capscrew Markings and Torque Values - U.S. Customary

SAE Grade Number		5				8			
Capscrew Head Markings									
These are all SAE Grade 5 (3 line)									
									
		Capscrew Torque - Grade 5 Capscrew				Capscrew Torque - Grade 8 Capscrew			
Capscrew Body Size	Cast Iron		Aluminum		Cast Iron		Aluminum		
	N•m	ft-lb	N•m	ft-lb	N•m	ft-lb	N•m	ft-lb	
1/4 - 20	9	7	8	6	15	11	8	6	
1/4 - 28	12	9	9	7	18	13	9	7	
5/16 - 18	20	15	16	12	30	22	16	12	
5/16 - 24	23	17	19	14	33	24	19	14	
3/8 - 16	40	30	25	20	55	40	25	20	
3/8 - 24	40	30	35	25	60	45	35	25	
7/16 - 14	60	45	45	35	90	65	45	35	
7/16 - 20	65	50	55	40	95	70	55	40	
1/2 - 13	95	70	75	55	130	95	75	55	
1/2 - 20	100	75	80	60	150	110	80	60	
9/16 - 12	135	100	110	80	190	140	110	80	
9/16 - 18	150	110	115	85	210	155	115	85	
5/8 - 11	180	135	150	110	255	190	150	110	
5/8 - 18	210	155	160	120	290	215	160	120	
3/4 - 10	325	240	255	190	460	340	255	190	
3/4 - 16	365	270	285	210	515	380	285	210	
7/8 - 9	490	360	380	280	745	550	380	280	
7/8 - 14	530	390	420	310	825	610	420	310	
1 - 8	720	530	570	420	1100	820	570	420	
1 - 14	800	590	650	480	1200	890	650	480	

### Newton-Meter to Foot-Pound Conversion Chart

N•m	ft-lb	N•m	ft-lb	N•m	ft-lb
1	9 in-lb	55	41	155	114
5	44 in-lb	60	44	160	118
6	53 in-lb	65	48	165	122
7	62 in-lb	70	52	170	125
8	71 in-lb	75	55	175	129
9	80 in-lb	80	59	180	133
10	89 in-lb	85	63	185	136
11	97 in-lb	90	66	190	140
12	106 in-lb	95	70	195	144
14	124 in-lb	100	74	200	148
15	133 in-lb	105	77	205	151
16	142 in-lb	110	81	210	155
18	159 in-lb	115	85	215	159
20	15 ft-lb	120	89	220	162
25	18	125	92	225	165
30	22	130	96	230	170
35	26	135	100	235	173
40	30	140	103	240	177
45	33	145	107	245	180
50	37	150	111	250	184

**NOTE:** To convert from Newton-Meters to Kilogram-Meters divide Newton-Meters by 9.803.

**Fraction, Decimal, Millimeter Conversions**

Fraction	inch	mm	Fraction	inch	mm
1/64	0.0156	0.397	33/64	0.5156	13.097
1/32	0.0313	0.794	17/32	0.5313	13.494
3/64	0.0469	1.191	35/64	0.5469	13.891
1/16	0.0625	1.588	9/16	0.5625	14.288
5/64	0.0781	1.984	37/64	0.5781	14.684
3/32	0.0938	2.381	19/32	0.5938	15.081
7/64	0.1094	2.778	39/64	0.6094	15.478
1/8	0.1250	3.175	5/8	0.6250	15.875
9/64	0.1406	3.572	41/64	0.6406	16.272
5/32	0.1563	3.969	21/32	0.6563	16.669
11/64	0.1719	4.366	43/64	0.6719	17.066
3/16	0.1875	4.763	11/16	0.6875	17.463
13/64	0.2031	5.159	45/64	0.7031	17.859
7/32	0.2188	5.556	23/32	0.7188	18.256
15/64	0.2344	5.953	47/64	0.7344	18.653
1/4	0.2500	6.350	3/4	0.7500	19.050
17/64	0.2656	6.747	49/64	0.7656	19.447
9/32	0.2813	7.144	25/32	0.7813	19.844
19/64	0.2969	7.541	51/64	0.7969	20.241
5/16	0.3125	7.938	13/16	0.8125	20.638
21/64	0.3281	8.334	53/64	0.8281	21.034
11/32	0.3438	8.731	27/32	0.8438	21.431
23/64	0.3594	9.128	55/64	0.8594	21.828
3/8	0.3750	9.525	7/8	0.8750	22.225
25/64	0.3906	9.922	57/64	0.8906	22.622
13/32	0.4063	10.319	29/32	0.9063	23.019
27/64	0.4219	10.716	59/64	0.9219	23.416
7/16	0.4375	11.113	15/16	0.9375	23.813
29/64	0.4531	11.509	61/64	0.9531	24.209
15/32	0.4688	11.906	31/32	0.9688	24.606
31/64	0.4844	12.303	63/64	0.9844	25.003
1/2	0.5000	12.700	1	1.0000	25.400

Conversion Factor: 1 inch = 25.4 mm



### Pipe Plug Torque Values

Size		Torque		Torque	
Thread	Actual Thread O.D.	In Aluminum Components		In Cast Iron or Steel Components	
in	in	N•m	ft-lb	N•m	ft-lb
1/16	0.32	5	45 in-lb	15	10
1/8	0.41	15	10	20	15
1/4	0.54	20	15	25	20
3/8	0.68	25	20	35	25
1/2	0.85	35	25	55	40
3/4	1.05	45	35	75	55
1	1.32	60	45	95	70
1-1/4	1.66	75	55	115	85
1-1/2	1.90	85	65	135	100

### Tap-Drill Chart - U.S. Customary and Metric

NOTE ON SELECTING TAP-DRILL SIZES: The tap drill sizes shown on this card give the theoretical tap drill size for approximately 60% and 75% of full thread depth. Generally, it is recommended that drill sizes be selected in the 60% range as these sizes will provide about 90% of the potential holding power. Drill sizes in the 75% range are recommended for shallow hole tapping (less than 1 1/2 times the hole diameter) in soft metals and mild steel.

Tap Size		Drill Size	Tap Size		Drill Size	Tap Size		Drill Size	Tap Size		Drill Size
60%	75%		60%	75%		60%	75%		60%	75%	
		48			4.40mm			7.50mm			13.25mm
		1.95mm			16			19/64			17/32
		5/64			4.50mm			7.60mm			13.50mm
	3-48	47			15			N	M15x1.5	M15x1.5	13.75mm
	M2.5x.45	2.00mm	12-24	M5.5x.9	4.60mm			7.70mm	5/8-11		35/64
		2.05mm			14		M9x1.25	7.75mm		M16x2	14.00mm
		46			13			7.80mm			14.25mm
3-48	3056	45			4.70mm			7.90mm		5/8-18	9/16
		2.10mm			4.75mm			5/16	M16x2	M16x1.5	14.50mm
M2.5x.45	M2.6x.45	2.15mm	M5.5x.9	12-28	3/16	M9x1.25	3/8-16	8.00mm	5/8-18		37/64
3-56	4-36	44			12		M9x1	O			14.75mm
		2.20mm			4.80mm			8.10mm			15.00mm
		2.25mm			11			8.20mm	M16x1.5		19.32
M2.6x.45		43			9			8.25mm			15.25mm
4-36	4-40	2.30mm			10			8.30mm			39/64
		2.35mm			8		3/8-16	21/64		M17x1.5	15.50mm
	4-48	42			5.00mm			8.40mm	M17x1.5	M18x2.5	15.75mm
		3/32			8			Q			5/8
	M3x.6	2.40mm			5.10mm			3/8-24			16.00mm
		41			7			M10x1.5	M18x2.5	M18x2	16.25mm
		2.45mm			13/64						41/64
		40			6						16.50mm
M3x.6	M3x.5	2.50mm	M6x1		5.20mm			R			21/32
		39			5		3/8-24	8.70mm			16.75mm
		38			5.25mm		1/8-27NPT	11/32		3/4-10	17.00mm
M3x.5	5-40	2.60mm			5.30mm			M10x1.25	M18x1.5	M19x2.5	43/64
5-40		37			4						17.25mm
	5-44	2.70mm	1/4-20	M6x.75	5.40mm			8.80mm			11/16
		36			3			S			17.50mm
	6-32	2.75mm	M6x.75		5.50mm			8.90mm	3/4-16	3/4-16	17.75mm
		7/64			7/32			9.00mm		M20x2.5	45/64
		35			5.60mm			T			18.00mm
		2.80mm			2			9.10mm			18.25mm
		34			5.70mm			23/64	M20x2.5	M20x2	23/32
		33			5.75mm			9.20mm			18.50mm
6-32	6-40	2.90mm	1/4-28		1			9.30mm			47/64
	M3.5x6	32			5.80mm			U			18.75mm
		3.00mm			5.90mm			9.40mm	M20x1.5		19.00mm
M3.5x6		31			A			9.50mm			3/4
6-40		3.10mm			15/64			3/8			19.25mm
		1/8			6.00mm			V			49/64
		3.20mm			B			9.60mm		7/8-9	19.50mm
		3.25mm			6.10mm			9.70mm		M22x2.5	25/32
	M4x.75	30			C			9.75mm			19.75mm
		3.30mm			6.20mm			9.80mm			20.00mm
M4x.75	M4x.7	3.40mm	M7x1		D			9.90mm	M22x2.5	M22x2	51/64
M4x.7		29			6.25mm			25/64		7/8-14	20.25mm
	8-32	3.50mm			6.30mm			10.00mm	M22x2		20.50mm
		28			E			X			13/16
	8-36	9/64			1/4			10.20mm	7/8-14	M22x1.5	20.75mm
		3.60mm			6.40mm			Y			21.00mm
		27			6.50mm			13/32	M22x1.5	M24x3	53/64
		3.70mm			F			Z			21/25mm
		26			6.60mm			10.50mm			27/32
	M4.5x.75	3.75mm			G			10.75mm			21.50mm
	10-24	25			6.70mm			11.00mm	M24x3		21.75mm
		3.80mm			17/64			7/16			55/64
		24			6.75mm						22.00mm
M4.5x.75		3.90mm			H						7/8
		23			6.80mm			11.25mm			22.25mm
		5/32			6.90mm			29/64			22.50mm
		22			I			11.75mm			57/64
		4.00mm			7.00mm			11.50mm			22.75mm
	M5x1	21			J			12.00mm			23.00mm
	10-32	20			7.10mm			12.25mm			29/32
		4.10mm			K			31/64			59/64
M5x1	M5x.9	4.20mm			9/32			12.50mm			23.50mm
10-32	M5x.8	19			7.20mm			12.50mm			23.75mm
M5x.9		4.25mm			7.25mm			1/2			15/16
M5x.8		4.30mm			7.30mm						
		18			L						
		11/64			7.40mm						
		17			M						

17800013

### Weights and Measures - Conversion Factors

Quantity	U.S. Customary		Metric		From U.S. Customary To Metric Multiply By	From Metric To U.S. Customary Multiply By
	Unit Name	Abbreviation	Unit Name	Abbreviation		
Area	sq. inch	in <sup>2</sup>	sq. millimeters	mm <sup>2</sup>	645.16	0.001550
			sq. centimeters	cm <sup>2</sup>	6.452	0.155
	sq. foot	ft <sup>2</sup>	sq. meter	m <sup>2</sup>	0.0929	10.764
Fuel Consumption	pounds per horsepower hour	lb/hp-hr	grams per kilowatt hour	g/kW-hr	608.277	0.001645
Fuel Performance	miles per gallon	mpg	kilometers per liter	km/l	0.4251	2.352
	gallons per mile	gpm	liters per kilometer	l/km	2.352	0.4251
Force	pounds force	lbf	Newton	N	4.4482	0.224809
Length	inch	in	millimeters	mm	25.40	0.039370
	foot	ft	millimeters	mm	304.801	0.00328
Power	horsepower	hp	kilowatt	kW	0.746	1.341
Pressure	pounds force per sq. inch	psi	kilopascal	kPa	6.8948	0.145037
	inches of mercury	in Hg	kilopascal	kPa	3.3769	0.29613
	inches of water	in H <sub>2</sub> O	kilopascal	kPa	0.2488	4.019299
	inches of mercury	in Hg	millimeters of mercury	mm Hg	25.40	0.039370
	inches of water	in H <sub>2</sub> O	millimeters of water	mm H <sub>2</sub> O	25.40	0.039370
	bars	bars	kilopascals	kPa	100.001	0.00999
	bars	bars	millimeters of mercury	mm Hg	750.06	0.001333
Temperature	fahrenheit	°F	centigrade	°C	(°F-32) ÷ 1.8	(1.8 x °C) + 32
Torque	pound force per foot	ft-lb	Newton-meter	N•m	1.35582	0.737562
	pound force per inch	in-lb	Newton-meter	N•m	0.113	8.850756
Velocity	miles/hour	mph	kilometers/hour	kph	1.6093	0.6214
Volume: liquid displacement	gallon (U.S.)	gal.	liter	l	3.7853	0.264179
	gallon (Imp*)	gal.	liter	l	4.546	0.219976
	cubic inch	in <sup>3</sup>	liter	l	0.01639	61.02545
	cubic inch	in <sup>3</sup>	cubic centimeter	cm <sup>3</sup>	16.387	0.06102
Weight (mass)	pounds (avoir.)	lb	kilograms	kg	0.4536	2.204623
Work	British Thermal Unit	BTU	joules	J	1054.5	0.000948
	British Thermal Unit	BTU	kilowatt-hour	kW-hr	0.000293	3414
	horsepower hours	hp-hr	kilowatt-hour	kW-hr	0.746	1.341



# Section M - Component Manufacturers

## Section Contents

	Page
<b>Component Manufacturers' Addresses</b> .....	M-1
Air Compressors.....	M-1
Air Cylinders .....	M-1
Air Heaters.....	M-1
Air Starting Motors .....	M-1
Alternators.....	M-1
Auxiliary Brakes .....	M-1
Belts.....	M-1
Catalytic Converters .....	M-1
Clutches.....	M-1
Coolant Heaters .....	M-2
Coolant Level Switches .....	M-1
Drive Plates.....	M-2
Electric Starting Motors .....	M-2
Electronic Switches .....	M-2
Engine Protection Controls .....	M-2
Fan Clutches .....	M-2
Fans.....	M-2
Fault Lamps .....	M-2
Filters.....	M-2
Flexplates.....	M-2
Fuel Coolers.....	M-2
Fuel Pumps.....	M-2
Fuel Warmers.....	M-2
Gauges .....	M-3
Governors .....	M-3
Heat Sleeves .....	M-3
Hydraulic and Power Steering Pumps.....	M-3
In-Line Connectors .....	M-3
Oil Heaters.....	M-3
Prelubrication Systems .....	M-3
Radiators.....	M-3
Throttle Assemblies .....	M-3
Torque Converters .....	M-3

**THIS PAGE LEFT INTENTIONALLY BLANK**

**Component Manufacturers' Addresses**

**NOTE:** The following list contains addresses and telephone numbers of suppliers of accessories used on Cummins engines. Suppliers can be contacted directly for any specifications **not** covered in this manual.

**Air Compressors**

Bendix Heavy Vehicles Systems  
Div. of Allied Automotive  
901 Cleveland Street  
Elyria, OH 44036  
Telephone: (216) 329-9000

Holset Engineering Co., Inc.  
1320 Kemper Meadow Drive  
Suite 500  
Cincinnati, OH 45240  
Telephone: (513) 825-9600

Midland-Grau  
Heavy Duty Systems  
Heavy Duty Group Headquarters  
10930 N. Pamona Avenue  
Kansas City, MO 64153  
Telephone: (816) 891-2470

**Air Cylinders**

Bendix Ltd.  
Douglas Road  
Kingswood  
Bristol  
England  
Telephone: 0117-671881

Catching Engineering  
1733 North 25th Avenue  
Melrose Park, IL 60160  
Telephone: (708) 344-2334

TEC - Hackett Inc.  
8909 Rawles Avenue  
Indianapolis, IN 46219  
Telephone: (317) 895-3670

**Air Heaters**

Fleetguard, Inc.  
1200 Fleetguard Road  
Cookeville, TN 38502  
Telephone: (615) 526-9551

Kim Hotstart Co.  
P.O. Box 11245  
Spokane, WA 99211-0245  
Telephone: (509) 534-6171

**Air Starting Motors**

Ingersoll Rand  
Chorley New Road  
Horwich  
Bolton  
Lancashire  
England  
BL6 6JN  
Telephone: 01204-65544

Ingersoll-Rand Engine  
Starting Systems  
888 Industrial Drive  
Elmhurst, IL 60126  
Telephone: (708) 530-3875

StartMaster  
Air Starting Systems  
A Division of Sycon Corporation  
9595 Cheney Avenue  
P. O. Box 491  
Marion, OH 43302  
Telephone: (614) 382-5771

**Alternators**

Robert Bosch Ltd.  
P.O. Box 98  
Broadwater Park  
North Orbital Road  
Denham  
Uxbridge  
Middlesex UD9 5HG  
England  
Telephone: 01895-833633

Butec Electrics  
Cleveland Road  
Leyland  
PR5 1XB  
England  
Telephone: 01744-21663

C.A.V. Electrical Equipment  
P.O. Box 36  
Warple Way  
London  
W3 7SS  
England  
Telephone: 01-743-3111

A.C. Delco Components Group  
Civic Offices  
Central Milton Keynes  
MK9 3EL  
England  
Telephone: 01908-66001

C. E. Niehoff & Co.  
2021 Lee Street  
Evanston, IL 60202  
Telephone: (708) 866-6030

Delco-Remy America  
2401 Columbus Avenue  
P.O. Box 2439  
Anderson, IN 46018  
Telephone: (317) 646-3528

Leece-Neville Corp.  
400 Main Street  
Arcade, NY 14009  
Telephone: (716) 492-1700

**Auxiliary Brakes**

The Jacobs Manufacturing Company  
Vehicle Equipment Division  
22 East Dudley Town Road  
Bloomfield, CT 06002  
Telephone: (203) 243-1441

**Belts**

Dayco Rubber U.K.  
Sheffield Street  
Stockport  
Cheshire  
SK4 1RV  
England  
Telephone: 061-432-5163

T.B.A. Belting Ltd.  
P.O. Box 77  
Wigan  
Lancashire  
WN2 4XQ  
England  
Telephone: 01942-59221

Dayco Mfg.  
Belt Technical Center  
1955 Enterprize  
Rochester Hills, MI 48309  
Telephone: (810) 853-8300

Gates Rubber Company  
900 S. Broadway  
Denver, CO 80217

Goodyear Tire and  
Rubber Company  
Industrial Products Div.  
2601 Fortune Circle East  
Indianapolis, IN 46241  
Telephone: (317) 898-4170

**Catalytic Converters**

Donaldson Company, Inc.  
1400 West 94th Street  
P.O. Box 1299  
Minneapolis, MN 55440  
Telephone: (612) 887-3835

Nelson Division  
Exhaust and Filtration Systems  
1801 U.S. Highway 51 P.O. Box 428  
Stoughton, WI 53589  
Telephone: (608) 873-4200

Walker Manufacturing  
3901 Willis Road  
P.O. Box 157  
Grass Lake, MI 49240  
Telephone: (517) 522-5500

**Coolant Level Switches**

Robertshaw Controls Company  
P.O. Box 400  
Knoxville, TN 37901  
Telephone: (216) 885-1773

**Clutches**

Twin Disc International S.A.  
Chaussee de Namur  
Nivelles  
Belguim  
Telephone: 067-224941

Twin Disc Incorporated  
1328 Racine Street  
Racine, WI 53403  
Telephone: (414) 634-1981

### Coolant Heaters

Fleetguard, Inc.  
1200 Fleetguard Road  
Cookeville, TN 38502  
Telephone: (615) 526-9551

### Drive Plates

Detroit Diesel Allison  
Division of General Motors  
Corporation  
P.O. Box 894  
Indianapolis, IN 46206-0894  
Telephone: (317) 242-5000

### Electric Starting Motors

Butec Electrics  
Cleveland Road  
Leyland  
PR5 1XB  
England  
Telephone: 01744-21663

C.A.V. Electrical Equipment  
P.O. Box 36  
Warple Way  
London  
W3 7SS  
England  
Telephone: 01-743-3111

A.C. Delco Components Group  
Civic Offices  
Central Milton Keynes  
MK9 3EL  
England  
Telephone: 0908-66001

Delco-Remy America  
2401 Columbus Avenue  
P.O. Box 2439  
Anderson, IN 46018  
Telephone: (317) 646-3528

Leece-Neville Corp.  
400 Main Street  
Arcade, NY 14009  
Telephone: (716) 492-1700

Nippondenso Inc.  
2477 Denso Drive  
P.O. Box 5133  
Southfield, MI 48086  
Telephone: (313) 350-7500

### Electronic Switches

Cutler-Hammer Products  
Eaton Corporation  
4201 N. 27th Street  
Milwaukee, WI 53216  
Telephone: (414) 449-6600

### Engine Protection Controls

Flight Systems Headquarters  
Hempt Road  
P.O. Box 25  
Mechanicsburg, PA 17055  
Telephone: (717) 697-0333

The Nason Company  
2810 Blue Ridge Blvd.  
West Union, SC 29696  
Telephone: (803) 638-9521

Teddington Industrial  
Equipment  
Windmill Road  
Sunburn on Thames  
Middlesex  
TW16 7HF  
England  
Telephone: 09327-85500

### Fan Clutches

Kysor Cooling Systems N.A.  
6040 West 62nd Street  
Indianapolis, IN 46278  
Telephone: (317) 328-3330

Holset Engineering Co. Ltd.  
P.O. Box A9  
Turnbridge  
Huddersfield, West Yorkshire  
England HD6 7RD  
Telephone: 01484-22244

Horton Industries, Inc.  
P.O. Box 9455  
Minneapolis, MN 55440  
Telephone: (612) 378-6410

Rockford Clutch Company  
1200 Windsor Road  
P.O. Box 2908  
Rockford, IL 61132-2908  
Telephone: (815) 633-7460

### Fans

Truflco Ltd.  
Westwood Road  
Birmingham  
B6 7JF  
England  
Telephone: 021-557-4101

Hayes-Albion Corporation  
Jackson Manufacturing Plant  
1999 Wildwood Avenue  
Jackson, MI 49202  
Telephone: (517) 782-9421

Engineered Cooling Systems, Inc.  
201 W. Carmel Drive  
Carmel, IN 46032  
Telephone: (317) 846-3438

Brookside Corporation  
P.O. Box 30  
McCordsville, IN 46055  
Telephone: (317) 335-2014

TCF Aerovent Company  
9100 Purdue Rd., Suite 101  
Indianapolis, IN 46268-1190  
Telephone: (317) 872-0030

Kysor-Cadillac  
1100 Wright Street  
Cadillac, MI 49601  
Telephone: (616) 775-4681

Schwitzer  
6040 West 62nd Street  
P.O. Box 80-B  
Indianapolis, IN 46206  
Telephone: (317) 328-3010

### Fault Lamps

Cutler-Hammer Products  
Eaton Corporation  
4201 N. 27th Street  
Milwaukee, WI 53216  
Telephone: (414) 449-6600

### Filters

Fleetguard International Corp.  
Cavalry Hill Industrial Park  
Weedon  
Northampton NN7 4TD  
England  
Telephone: 01327-41313

Fleetguard, Inc.  
1200 Fleetguard Road  
Cookeville, TN 38502  
Telephone: 1-800-22-Filters  
(1-800-223-4583)

### Flexplates

Corrugated Packing and  
Sheet Metal  
Hamsterley  
Newcastle Upon Tyne  
England  
Telephone: 01207-560-505

Allison Transmission  
Division of General Motors  
Corporation  
P.O. Box 894  
Indianapolis, IN 46206-0894  
Telephone: (317) 242-5000

Midwest Mfg. Co.  
29500 Southfield Road, Suite 122  
Southfield, MI 48076  
Telephone: (313) 642-5355

Wohlert Corporation  
708 East Grand River Avenue  
P.O. Box 20217  
Lansing, MI 48901  
Telephone: (517) 485-3750

### Fuel Coolers

Hayden, Inc.  
1531 Pomona Road  
P.O. Box 848  
Corona, CA 91718-0848  
Telephone: (909) 736-2665

### Fuel Pumps

Robert Bosch Corp.  
Automotive Group  
2800 South 25th Ave.  
Broadview, IL 60153

### Fuel Warmers

Fleetguard, Inc.  
1200 Fleetguard Road  
Cookeville, TN 38502  
Telephone: (615) 526-9551



**Gauges**

A.I.S.  
Dyffon Industrial Estate  
Ystrad Mynach  
Hengoed  
Mid Glamorgan  
CF8 7XD  
England  
Telephone: 01443-812791

Grasslin U.K. Ltd.  
Vale Rise  
Tonbridge  
Kent  
TN9 1TB  
England  
Telephone: 01732-359888

Icknield Instruments Ltd.  
Jubilee Road  
Letchworth  
Herts  
England  
Telephone: 04626-5551

Superb Tool and Gauge Co.  
21 Princip Street  
Birmingham  
B4 61E  
England  
Telephone: 021-359-4876

Kabi Electrical and Plastics  
Cranborne Road  
Potters Bar  
Herts  
EN6 3JP  
England  
Telephone: 01707-53444

Datcon Instruments  
P.O. Box 128  
East Petersburg, PA 17520  
Telephone: (717) 569-5713

Rochester Gauges, Inc.  
11616 Harry Hines Blvd.  
P.O. Box 29242  
Dallas, TX 75229  
Telephone: (214) 241-2161

**Governors**

Woodward Governors Ltd.  
P.O. Box 15  
663/664 Ajax Avenue  
Slough  
Bucks  
SL1 4DD  
England  
Telephone: 01753-26835

Woodward Governor Co.  
P.O. Box 1519  
Fort Collins, CO 80522  
Telephone: (303) 482-5811  
(800) 523-2831

Barber Colman Co.  
1354 Clifford Avenue  
Loves Park, IL 61132  
Telephone: (815) 637-3000

United Technologies  
Diesel Systems  
1000 Jorie Blvd.  
Suite 111  
Oak Brook, IL 69521  
Telephone: (312) 325-2020

**Heat Sleeves**

Bentley Harris Manufacturing Co.  
100 Bentley Harris Way  
Gordonville, TN 38563  
Telephone: (313) 348-5779

**Hydraulic and Power Steering Pumps**

Hobourn Automotive  
Temple Farm Works  
Priory Road  
Strood  
Rochester  
Kent, England  
ME2 2BD  
Telephone: 01634-71773

Honeywell Control Systems Ltd.  
Honeywell House  
Charles Square  
Bracknell  
Berks RG12 1EB  
Telephone: 01344-4245

Sundstrand Hydratec Ltd.  
Cheney Manor Trading Estate  
Swindon  
Wiltshire  
SN2 2PZ  
England  
Telephone: 01793-30101

Sperry Vickers  
P.O. Box 302  
Troy, MI 48084  
Telephone: (313) 280-3000

Z.F.  
P.O. Box 1340  
Grafvonsoden Strasse  
5-9 D7070  
Schwaebisch Gmuend  
Germany  
Telephone: 7070-7171-31510

**In-Line Connectors**

Pioneer-Standard Electronics, Inc.  
5440 Neiman Parkway  
Solon, OH 44139  
Telephone: (216) 349-1300

Deutsch  
Industrial Products Division  
37140 Industrial Avenue  
Hemet, CA 92343  
Telephone: (714) 929-1200

**Oil Heaters**

Fleetguard, Inc.  
1200 Fleetguard Road  
Cookeville, TN 38502  
Telephone: (615) 526-9551

Kim Hotstart Co.  
P.O. Box 11245  
Spokane, WA 99211-0245  
Telephone: (509) 534-6171

**Prelubrication Systems**

RPM Industries, Inc.  
Suite 109  
55 Hickory Street  
Washington, PA 15301  
Telephone: (412) 228-5130

**Radiators**

JB Radiator Specialties, Inc.  
P.O. Box 292087  
Sacramento, CA 95829-2087  
Telephone: (916) 381-4791

The G&O Manufacturing Company  
100 Gando Drive  
P.O. Box 1204  
New Haven, CT 06505-1204  
Telephone: (203) 562-5121

Young Radiator Company  
2825 Four Mile Road  
Racine, WI 53404  
Telephone: (910) 271-2397

L and M Radiator, Inc.  
1414 East 37th Street  
Hibbing, MN 55746  
Telephone: (218) 263-8993

**Throttle Assemblies**

Williams Controls, Inc.  
14100 SW 72nd Avenue  
Portland, OR 97224  
Telephone: (503) 684-8600

**Torque Converters**

Twin Disc International S.A.  
Chaussee de Namur  
Nivelles  
Belgium  
Telephone: 067-224941

Twin Disc Incorporated  
1328 Racine Street  
Racine, WI 53403-1758  
Telephone: (414) 634-1981

Rockford Powertrain, Inc.  
Off-Highway Systems  
1200 Windsor Road  
P.O. Box 2908  
Rockford, IL 61132-2908  
Telephone: (815) 633-7460

Modine Mfg. Co.  
1500 DeKoven Avenue  
Racine, WI 53401  
Telephone: (414) 636-1640



# Section L - Service Literature

## Section Contents

	Page
Additional Service Literature.....	L-1
Service Literature Ordering Location.....	L-2

**THIS PAGE LEFT INTENTIONALLY BLANK**

## Additional Service Literature

The following publications can be purchased by contacting the nearest local distributor.

<b>Bulletin No.</b>	<b>Title of Publication</b>
3810207	Troubleshooting and Repair Manual, B Series - Applicable to Engines Built Prior to 1991
3666087	Troubleshooting and Repair Manual, B3.9 and B5.9 Series Engines
3810205	Operation and Maintenance Manual, Automotive, RV, Bus, and Industrial, B3.9 and B5.9 Series Engines
3810464	Operation and Maintenance Manual (Worldwide), Automotive, RV, Bus, and Industrial, B3.9 and B5.9 Series Engines
3666017	B Series Shop Manual - Applicable to Engines Built During 1991 and Beyond
3666109	Alternate Repair Manual, B Series Engines
3810206	B Series Shop Manual - Applicable to Engines Built Prior to 1991
3666029	Standard Repair Times, 4B Series Engines
3666028	Standard Repair Times, 6B Series Engines
3666022	B and C Series Marine Propulsion Units
3379034	Publications and Training Aids

## Service Literature Ordering Location

**Region**

**Ordering Location**

United States and Canada

Cummins Distributors  
or  
Contact 1-800-DIESELS  
(1-800-343-7357)

U.K., Europe, Mid-East, Africa,  
and Eastern European Countries

Cummins Engine Co., Ltd.  
Royal Oak Way South  
Daventry  
Northants, NN11 5NU, England

South and Central America  
(excluding Brazil and Mexico)

Cummins Americas, Inc.  
16085 N.W. 52nd Avenue  
Hialeah, FL 33104

Brazil and Mexico

Cummins Engine Co., Inc.  
International Parts Order Dept., MC 40931  
Box 3005  
Columbus, IN 47202-3005

Far East (excluding  
Australia and New Zealand)

Cummins Diesel Sales Corp.  
Literature Center  
8 Tanjong Penjuru  
Jurong Industrial Estate  
Singapore

Australia and New Zealand

Cummins Diesel Australia  
Maroondah Highway, P.O.B. 139  
Ringwood 3134  
Victoria, Australia

Obtain current price information from your local Cummins Distributor.

<b>About the Manual</b> .....	i-1	<b>Air Intake System - Torque Values</b> .....	V-32
<b>Acronyms and Abbreviations</b> .....	i-4	Aftercooler.....	V-32
<b>Additional Service Literature</b> .....	L-1	Air Crossover.....	V-32
<b>AFC Air Tube</b> .....	6-2	Air Intake Manifold.....	V-32
Inspect for Reuse.....	6-2	Air Intake Manifold Heater.....	V-33
Install.....	6-2	Air Leaks, Air Intake and Exhaust Systems.....	V-32
Remove.....	6-2	Turbocharger.....	V-32
<b>AFC Assembly</b> .....	5-9	Turbocharger Oil Drain Line.....	V-33
General Information.....	5-9	Turbocharger Oil Supply Line.....	V-33
<b>Aftercooler</b> .....	10-15	Turbocharger Radial Bearing Clearance.....	V-33
Clean.....	10-15	Turbocharger Turbine Seal Leaks.....	V-33
Fill.....	10-16	Turbocharger Wastegate Actuator.....	V-33
Install.....	10-16	<b>Air Leaks, Air Intake and Exhaust Systems</b> .....	10-19
Preparatory.....	10-15	Initial Check.....	10-19
Remove.....	10-15	<b>Air Leaks, Compressed Air System</b> .....	12-21
<b>Air Compressor Carbon Buildup</b> .....	12-9	Leak Test.....	12-21
Initial Check.....	12-9	<b>Alternator</b> .....	13-12
<b>Air Compressor Coolant Lines</b> .....	12-10	Initial Check.....	13-12
Install.....	12-10	Install.....	13-17
Remove.....	12-10	Preparatory.....	13-15
<b>Air Compressor Cylinder Head (Holset® QE Models)</b> .....	12-35	Remove.....	13-15
Assemble.....	12-43	Test.....	13-16
Clean.....	12-40	<b>Alternator Bracket</b> .....	13-18
Disassemble.....	12-37	Install.....	13-18
General Information.....	12-35	Remove.....	13-18
Inspect for Reuse.....	12-40	<b>Alternator Pulley</b> .....	13-18
<b>Air Compressor Cylinder Head (Holset® SS191 Model)</b> .....	12-22	Install.....	13-19
Assemble.....	12-30	Preparatory.....	13-18
Clean.....	12-25	Remove.....	13-18
Disassemble.....	12-23	<b>Batteries</b> .....	13-19
Inspect for Reuse.....	12-26	Initial Check.....	13-19
Install.....	12-33	<b>Battery Cables and Connections</b> .....	13-23
Preparatory.....	12-22	Initial Check.....	13-23
Remove.....	12-22	<b>Bearings, Connecting Rod</b> .....	1-5
<b>Air Compressor Pin Bore Wear</b> .....	12-11	Clean.....	1-8
Initial Check.....	12-11	General Information.....	1-5
<b>Air Compressor Unloader and Valve Assembly</b> .....	12-14	Inspect for Reuse.....	1-8
Clean.....	12-15	Install.....	1-9
Initial Check.....	12-14	Preparatory.....	1-6
Inspect for Reuse.....	12-15	Remove.....	1-6
Install.....	12-16	<b>Bearings, Main</b> .....	1-12
Remove.....	12-14	Clean.....	1-15
<b>Air Crossover</b> .....	10-16	General Information.....	1-12
Inspect for Reuse.....	10-17	Inspect for Reuse.....	1-15
Install.....	10-17	Install.....	1-17
Remove.....	10-16	Measure.....	1-16
<b>Air Governor (Air Compressor Pumps Continuously)</b> .....	12-19	Preparatory.....	1-13
Test.....	12-19	Remove.....	1-13
<b>Air Governor (Air Compressor Will Not Pump)</b> .....	12-18	<b>Cam Followers/Tappets - General Information</b> .....	4-2
Test.....	12-18	<b>Cam Followers/Tappets - Specifications</b> .....	V-13
<b>Air in Fuel</b> .....	6-3	Tappet.....	V-13
General Information.....	6-3	<b>Cam Followers/Tappets - Torque Values</b> .....	V-14
Measure.....	6-4	Push Rods or Tubes.....	V-14
Test.....	6-5	<b>Camshaft</b> .....	1-20
<b>Air Intake Manifold</b> .....	10-17	Clean.....	1-24
Clean.....	10-18	General Information.....	1-20
Inspect for Reuse.....	10-18	Inspect for Reuse.....	1-24
Install.....	10-18	Install.....	1-31
Preparatory.....	10-17	Preparatory.....	1-22
Remove.....	10-18	Remove.....	1-22
<b>Air Intake Manifold Heater</b> .....	10-52	<b>Camshaft Bushings</b> .....	1-34
General Information.....	10-52	Initial Check.....	1-34
Install.....	10-64	Install.....	1-35
Maintenance Check.....	10-61	Measure.....	1-36
Remove.....	10-63	Remove.....	1-34
<b>Air Intake Restriction</b> .....	10-26	<b>Camshaft Gear (Camshaft Removed)</b> .....	1-36
General Information.....	10-26	Clean.....	1-37
Measure.....	10-27	Inspect for Reuse.....	1-37
<b>Air Intake System - General Information</b> .....	10-14	Install.....	1-38
<b>Air Intake System - Specifications</b> .....	V-30	Preparatory.....	1-36
Air Intake Restriction.....	V-30	Remove.....	1-36
Charge-Air Cooler (CAC).....	V-30	<b>Capscrew Markings and Torque Values</b> .....	V-70
Turbocharger.....	V-30	Capscrew Markings and Torque Values - Metric.....	V-71
Turbocharger Axial Clearance.....	V-30	Capscrew Markings and Torque Values - U.S. Customary.....	V-72
Turbocharger Radial Bearing Clearance.....	V-30	<b>Charge-Air Cooler (CAC)</b> .....	10-22
Turbocharger Turbine Seal Leaks.....	V-31	Clean.....	10-22
Turbocharger Wastegate Actuator.....	V-31	General Information.....	10-22

Index  
Page 2

Inspect for Reuse .....	10-23	Test .....	1-44
Leak Test .....	10-24	<b>Coolant Heater</b> .....	8-6
Pressure Test .....	10-24	Clean .....	8-7
Temperature Differential Test .....	10-25	General Information .....	8-6
<b>Cold Start Timing Advance System (KSB) Pump Mounted</b> .....	5-100	Install .....	8-8
Assemble .....	5-107	Maintenance Check .....	8-7
Clean .....	5-106	Preparatory .....	8-7
Disassemble .....	5-106	Remove .....	8-7
General Information .....	5-100	<b>Coolant Temperature Sensor, OEM</b> .....	8-57
Resistance Check .....	5-103	Inspect for Reuse .....	8-57
Electrical Solenoid Style .....	5-104	Install .....	8-58
Wax-Motor Style .....	5-103	Preparatory .....	8-57
Test .....	5-106	Remove .....	8-57
<b>Cold Start Timing Advance System (KSB) Remote</b> .....	5-86	<b>Coolant Thermostat</b> .....	8-9
Assemble .....	5-91	Clean .....	8-12
Clean .....	5-90	General Information .....	8-9
Disassemble .....	5-89	Inspect for Reuse .....	8-12
General Information .....	5-86	Install .....	8-13
Resistance Check .....	5-92	Preparatory .....	8-11
Test .....	5-91	Remove .....	8-11
<b>Cold Start Timing Advance System (KSB) Temperature</b>		Test .....	8-12
<b>Switch</b> .....	5-98	<b>Coolant Thermostat Housing</b> .....	8-14
Install .....	5-100	General Information .....	8-14
Remove .....	5-98	<b>Cooling System</b> .....	8-14
Test .....	5-99	Clean .....	8-16
Electrical Solenoid Style .....	5-99	Drain .....	8-15
Wax-Motor Style .....	5-99	Fill .....	8-18
<b>Complete Engine - General Information</b> .....	0-2	Initial Check .....	8-14
<b>Component Manufacturers' Addresses</b> .....	M-1	Pressure Test .....	8-17
Air Compressors .....	M-1	<b>Cooling System - Air or Combustion Gas Test</b> .....	8-19
Air Cylinders .....	M-1	Combustion Gas Leak .....	8-21
Air Heaters .....	M-1	Overflow Method .....	8-19
Air Starting Motors .....	M-1	<b>Cooling System - General Information</b> .....	8-2
Alternators .....	M-1	<b>Cooling System - Specifications</b> .....	V-27
Auxiliary Brakes .....	M-1	Coolant Temperature Sensor, OEM .....	V-27
Belts .....	M-1	Coolant Thermostat .....	V-27
Catalytic Converters .....	M-1	Radiator Shutter Assembly .....	V-27
Clutches .....	M-1	Water Pump .....	V-27
Coolant Heaters .....	M-2	<b>Cooling System - Torque Values</b> .....	V-28
Coolant Level Switches .....	M-1	Coolant Heater .....	V-28
Drive Plates .....	M-2	Coolant Temperature Sensor, OEM .....	V-29
Electric Starting Motors .....	M-2	Coolant Thermostat .....	V-28
Electronic Switches .....	M-2	Fan Clutch, Electric .....	V-28
Engine Protection Controls .....	M-2	Fan, Cooling .....	V-28
Fan Clutches .....	M-2	Fan Spacer and Pulley .....	V-28
Fans .....	M-2	Sea Water Heat Exchanger .....	V-28
Fault Lamps .....	M-2	<b>Cooling System Diagnostics</b> .....	8-25
Filters .....	M-2	General Information .....	8-25
Flexplates .....	M-2	<b>Crankcase Blowby, Measure</b> .....	14-27
Fuel Coolers .....	M-2	Measure .....	14-27
Fuel Pumps .....	M-2	<b>Crankcase Breather Tube</b> .....	3-13
Fuel Warmers .....	M-2	Clean .....	3-14
Gauges .....	M-3	Inspect for Reuse .....	3-14
Governors .....	M-3	Install .....	3-14
Heat Sleeves .....	M-3	Remove .....	3-13
Hydraulic and Power Steering Pumps .....	M-3	<b>Crankshaft</b> .....	1-45
In-Line Connectors .....	M-3	Clean .....	1-48
Oil Heaters .....	M-3	General Information .....	1-45
Prelubrication Systems .....	M-3	Inspect for Reuse .....	1-48
Radiators .....	M-3	Install .....	1-50
Throttle Assemblies .....	M-3	Preparatory .....	1-46
Torque Converters .....	M-3	Remove .....	1-47
<b>Compressed Air System - General Information</b> .....	12-3	Rotation Check .....	1-53
<b>Compressed Air System - Specifications</b> .....	V-36	<b>Crankshaft Gear, Front (Crankshaft Installed)</b> .....	1-54
Air Compressor Cylinder Head (Holset® QE Models) .....	V-37	General Information .....	1-54
Air Compressor Cylinder Head (Holset® SS191 Model) .....	V-36	<b>Crankshaft Seal, Front</b> .....	1-54
<b>Compressed Air System - Torque Values</b> .....	V-38	Clean .....	1-55
Air Compressor Coolant Lines .....	V-38	General Information .....	1-54
Air Compressor Cylinder Head (Holset® QE Models) .....	V-39	Inspect for Reuse .....	1-55
Air Compressor Cylinder Head (Holset® SS191 Model) .....	V-38	Install .....	1-56
Air Compressor Unloader and Valve Assembly .....	V-38	Remove .....	1-54
<b>Connecting Rod</b> .....	1-40	<b>Crankshaft Seal, Rear</b> .....	1-57
Clean .....	1-41	Clean .....	1-58
Inspect for Reuse .....	1-41	Install .....	1-58
Install .....	1-44	Preparatory .....	1-57
Preparatory .....	1-40	Remove .....	1-58
Remove .....	1-41	<b>Crankshaft Wear Sleeve, Front</b> .....	1-59



Clean .....	1-60	<b>Engine Component Torque Values</b> .....	V-69
Inspect for Reuse .....	1-61	<b>Engine Dataplate</b> .....	1-108
Install .....	1-61	Install .....	1-108
Preparatory .....	1-59	Remove .....	1-108
Remove .....	1-60	<b>Engine Diagrams</b> .....	E-27
<b>Crankshaft Wear Sleeve, Rear</b> .....	1-109	Engine Views .....	E-27
Clean .....	1-111	<b>Engine Fuel Heater, Electric</b> .....	5-9
General Information .....	1-109	Initial Check .....	5-9
Inspect for Reuse .....	1-111	Install .....	5-10
Install .....	1-112	Remove .....	5-9
Preparatory .....	1-109	<b>Engine Identification</b> .....	E-1
Remove .....	1-110	Cummins Engine Nomenclature .....	E-2
<b>Cup Plug</b> .....	17-2	Engine Dataplate .....	E-1
Clean .....	17-2	Fuel Injection Pump Dataplate .....	E-3
Inspect for Reuse .....	17-2	General Information .....	E-1
Install .....	17-3	<b>Engine Installation</b> .....	0-5
Remove .....	17-2	<b>Engine Mounts</b> .....	16-23
<b>Cylinder Block</b> .....	1-63	Inspect for Reuse .....	16-23
Assemble .....	1-67	<b>Engine Oil Heater</b> .....	7-8
Clean .....	1-66	Install .....	7-8
Disassemble .....	1-65	Preparatory .....	7-8
General Information .....	1-63	Remove .....	7-8
Inspect for Reuse .....	1-67	<b>Engine Painting</b> .....	0-9
Preparatory .....	1-65	<b>Engine Removal</b> .....	0-2
<b>Cylinder Block - Specifications</b> .....	V-1	<b>Engine Run-in (Chassis Dynamometer)</b> .....	14-9
Bearings, Connecting Rod .....	V-1	Test .....	14-9
Bearings, Main .....	V-1	<b>Engine Run-in (Engine Dynamometer)</b> .....	14-18
Camshaft .....	V-1	Test .....	14-18
Camshaft Bushings .....	V-2	<b>Engine Run-in (Without Dynamometer)</b> .....	14-10
Connecting Rod .....	V-2	Test .....	14-10
Crankshaft .....	V-3	Off-Highway Applications .....	14-11
Piston .....	V-4	On-Highway Applications .....	14-10
Piston and Connecting Rod Assembly .....	V-5	<b>Engine Support Bracket, Front</b> .....	16-3
Piston Rings .....	V-4	Clean .....	16-3
Vibration Damper .....	V-5	Inspect for Reuse .....	16-3
<b>Cylinder Block - Torque Values</b> .....	V-6	Install .....	16-4
Bearings, Connecting Rod .....	V-6	Remove .....	16-3
Bearings, Main .....	V-6	<b>Engine Support Bracket, Rear</b> .....	16-4
Camshaft .....	V-6	Clean .....	16-5
Camshaft Gear (Camshaft Removed) .....	V-6	Inspect for Reuse .....	16-5
Connecting Rod .....	V-6	Install .....	16-5
Crankshaft .....	V-6	Remove .....	16-4
Crankshaft Seal, Front .....	V-7	<b>Engine Testing - General Information</b> .....	14-3
Crankshaft Seal, Rear .....	V-7	<b>Engine Testing - Specifications</b> .....	V-41
Gear Cover, Front .....	V-7	Engine Testing (Chassis Dynamometer) .....	V-41
Gear Housing, Front .....	V-7	Engine Testing (Engine Dynamometer) .....	V-41
Piston and Connecting Rod Assembly .....	V-8	Engine Testing (In Chassis) .....	V-42
Timing Pin Housing .....	V-7	<b>Engine Testing (Chassis Dynamometer)</b> .....	14-4
Vibration Damper .....	V-7	Setup .....	14-4
<b>Cylinder Head</b> .....	2-3	Test .....	14-6
Clean .....	2-6	<b>Engine Testing (Engine Dynamometer)</b> .....	14-12
Engine Noise Diagnostic Procedures - General Information .....	2-21	Setup .....	14-12
Inspect for Reuse .....	2-8	<b>Engine Testing (In Chassis)</b> .....	14-22
Install .....	2-11	Initial Check .....	14-22
Preparatory .....	2-3	Test .....	14-24
Remove .....	2-5	<b>Exhaust Manifold, Dry</b> .....	11-7
<b>Cylinder Head - General Information</b> .....	2-2	Clean .....	11-7
Cylinder Head And Valve Train .....	2-2	General Information .....	11-7
<b>Cylinder Head - Specifications</b> .....	V-9	Inspect for Reuse .....	11-8
Valve, Cylinder Head .....	V-9	Install .....	11-8
<b>Cylinder Head - Torque Values</b> .....	V-10	Preparatory .....	11-7
Cylinder Head .....	V-10	Remove .....	11-7
Valve, Cylinder Head .....	V-10	<b>Exhaust Restriction</b> .....	11-9
<b>Cylinder Head Gasket</b> .....	2-29	Measure .....	11-9
Install .....	2-29	<b>Exhaust System - Specifications</b> .....	V-34
Remove .....	2-29	Exhaust Restriction .....	V-34
<b>Drive Belt, Cooling Fan</b> .....	8-6	<b>Exhaust System - Torque Values</b> .....	V-35
Inspect for Reuse .....	8-6	Exhaust Manifold, Dry .....	V-35
Install .....	8-6	<b>Expansion Plug</b> .....	17-5
Remove .....	8-6	Clean .....	17-5
<b>Drive Belt Tension</b> .....	V-68	Install .....	17-6
<b>Electrical Equipment - General Information</b> .....	13-2	Remove .....	17-5
<b>Electrical Equipment - Torque Values</b> .....	V-40	<b>Fan Belt Tensioner</b> .....	8-58
Alternator Bracket .....	V-40	Install .....	8-59
Alternator Pulley .....	V-40	Preparatory .....	8-58
Starting Motor .....	V-40	Remove .....	8-58
<b>Electronic Wiring Diagrams</b> .....	13-4	<b>Fan Clutch, Electric</b> .....	8-32

**Index**  
**Page 4**

General Information .....	8-32	Preparatory .....	6-11
Install .....	8-34	Remove .....	6-11
Remove .....	8-33	<b>Fuel Pump Back Leakage Valve</b> .....	5-95
<b>Fan, Cooling</b> .....	8-38	Inspect for Reuse .....	5-96
General Information .....	8-38	Install .....	5-96
Inspect for Reuse .....	8-39	CAV .....	5-96
Install .....	8-39	Preparatory .....	5-95
Remove .....	8-38	Remove .....	5-95
<b>Fan Hub, Belt Driven</b> .....	8-35	CAV .....	5-95
Install .....	8-36	<b>Fuel Pump Control Lever and Spring</b> .....	5-56
Preparatory .....	8-35	Adjust .....	5-56
Remove .....	8-36	<b>Fuel Pump High Idle Speed</b> .....	5-56
<b>Fan Shroud Assembly</b> .....	8-36	General Information .....	5-56
Initial Check .....	8-36	<b>Fuel Pump Idle Speed</b> .....	5-56
<b>Fan Spacer and Pulley</b> .....	8-37	Adjust .....	5-56
Install .....	8-37	<b>Fuel Pump Pressure Regulator</b> .....	5-97
Preparatory .....	8-37	Clean .....	5-97
Remove .....	8-37	Inspect for Reuse .....	5-97
<b>Flow Diagram, Air Intake System</b> .....	10-3	Install .....	5-98
<b>Flow Diagram, Compressed Air System</b> .....	12-5	Remove .....	5-97
<b>Flow Diagram, Cooling System</b> .....	8-3	<b>Fuel Pump Support Bracket</b> .....	5-60
<b>Flow Diagram, Exhaust System</b> .....	11-2	Install .....	5-60
<b>Flow Diagram, Fuel System</b> .....	5-5	Remove .....	5-60
<b>Flow Diagram, Lubricating Oil System</b> .....	7-3	<b>Fuel Pump Timing</b> .....	5-61
<b>Flywheel</b> .....	16-6	General Information .....	5-61
Clean .....	16-7	Time .....	5-61
Inspect for Reuse .....	16-7	<b>Fuel Recommendations and Specifications</b> .....	5-8
Install .....	16-11	Fuel Recommendations .....	5-8
Measure .....	16-8	<b>Fuel Return Overflow Valve</b> .....	6-33
Remove .....	16-6	Clean .....	6-34
<b>Flywheel Housing</b> .....	16-13	Initial Check .....	6-33
Clean .....	16-14	Install .....	6-34
Inspect for Reuse .....	16-15	Remove .....	6-34
Install .....	16-18	<b>Fuel Shutoff Valve</b> .....	5-68
Measure .....	16-15	General Information .....	5-68
Remove .....	16-13	Install .....	5-74
<b>Flywheel Ring Gear</b> .....	16-21	Preparatory .....	5-69
Initial Check .....	16-22	Remove .....	5-70
Install .....	16-22	Test .....	5-71
Preparatory .....	16-21	<b>Fuel Supply Lines</b> .....	6-14
Remove .....	16-22	Install .....	6-16
<b>Fraction, Decimal, Millimeter Conversions</b> .....	V-74	Remove .....	6-14
<b>Fuel Consumption</b> .....	5-11	Vent .....	6-18
Measure .....	5-11	<b>Fuel System - General Information</b> .....	5-3
<b>Fuel Drain Line Restriction</b> .....	6-5	<b>Fuel System - Specifications</b> .....	V-15
Measure .....	6-5	Fuel Flow .....	V-15
<b>Fuel Filter (Spin-On Type)</b> .....	6-8	<b>Fuel System - Torque Values</b> .....	V-16
Install .....	6-9	Cold Start Timing Advance System (KSB) Pump Mounted ....	V-20
Remove .....	6-8	Cold Start Timing Advance System (KSB) Remote .....	V-20
<b>Fuel Flow</b> .....	5-15	Cold Start Timing Advance System (KSB) Temperature	
Pressure Test .....	5-15	Switch .....	V-20
<b>Fuel Injection Pump, In-Line, Spill Port Timing</b> .....	5-28	Engine Fuel Heater, Electric .....	V-16
Plunger Lift Timing .....	5-34	Fuel Injection Pump, In-Line, Spill Port Timing .....	V-16
Time .....	5-28	Fuel Injection Pump, Rotary .....	V-17
<b>Fuel Injection Pump, Rotary</b> .....	5-45	Fuel Injection Pumps, In-Line .....	V-16
General Information .....	5-45	Fuel Lift Pump .....	V-19
Install .....	5-51	Fuel Pump Idle Speed .....	V-18
Preparatory .....	5-48	Fuel Pump Support Bracket .....	V-18
Remove .....	5-48	Fuel Pump Timing .....	V-18
<b>Fuel Injection Pumps, In-Line</b> .....	5-17	Fuel Shutoff Valve .....	V-19
General Information .....	5-17	<b>Fuel-Water Separator</b> .....	6-32
Install .....	5-22	General Information .....	6-32
Preparatory .....	5-20	<b>Gear Cover, Front</b> .....	1-68
Remove .....	5-20	Clean .....	1-69
<b>Fuel Inlet Restriction</b> .....	6-9	Inspect for Reuse .....	1-70
Initial Check .....	6-9	Install .....	1-70
<b>Fuel Lift Pump</b> .....	5-75	Remove .....	1-68
Install .....	5-85	<b>Gear Housing, Front</b> .....	1-72
Preparatory .....	5-75	Clean .....	1-74
Remove .....	5-75	General Information .....	1-72
Test .....	5-76	Inspect for Reuse .....	1-75
Vent .....	5-85	Install .....	1-76
<b>Fuel Manifold (Drain)</b> .....	6-10	Preparatory .....	1-73
Clean .....	6-12	Remove .....	1-73
General Information .....	6-10	<b>General Cleaning Instructions</b> .....	i-7
Inspect for Reuse .....	6-12	Glass or Plastic Bead Cleaning .....	i-7
Install .....	6-13	Solvent and Acid Cleaning .....	i-7

Steam Cleaning .....	i-7	Install .....	7-41
<b>General Repair Instructions</b> .....	i-6	Remove .....	7-41
<b>General Safety Instructions</b> .....	i-5	<b>Lubricating Oil Pump</b> .....	7-21
Important Safety Notice .....	i-5	Inspect for Reuse .....	7-22
<b>How to Use the Manual</b> .....	i-1	Install .....	7-25
<b>Hydraulic Pump Drive</b> .....	9-1	Preparatory .....	7-21
Clean .....	9-1	Remove .....	7-21
Inspect for Reuse .....	9-2	<b>Lubricating Oil Suction Tube (Block-Mounted)</b> .....	7-28
Install .....	9-2	Clean .....	7-29
Remove .....	9-1	Fill .....	7-30
<b>Hydraulic Pump Drive Gear and Shaft</b> .....	9-3	Inspect for Reuse .....	7-29
Inspect for Reuse .....	9-3	Install .....	7-29
<b>Illustrations</b> .....	i-3	Preparatory .....	7-28
<b>Injector</b> .....	6-20	Remove .....	7-28
Assemble .....	6-29	<b>Lubricating Oil System - General Information</b> .....	7-2
Clean .....	6-24	<b>Lubricating Oil System - Specifications</b> .....	V-24
Disassemble .....	6-22	Lubricating Oil Cooler .....	V-24
General Information .....	6-20	Lubricating Oil Pump .....	V-24
Inspect for Reuse .....	6-26	<b>Lubricating Oil System - Torque Values</b> .....	V-25
Install .....	6-30	Engine Oil Heater .....	V-25
Measure .....	6-26	Lubricating Oil Cooler .....	V-25
Preparatory .....	6-21	Lubricating Oil Pan .....	V-25
Remove .....	6-21	Lubricating Oil Pressure Regulator (Main Rifle) .....	V-25
Test .....	6-27	Lubricating Oil Pressure Sensor, OEM .....	V-26
<b>Injector Protusion</b> .....	2-29	Lubricating Oil Suction Tube (Block-Mounted) .....	V-25
General Information .....	2-29	<b>Lubricating Oil System Diagnostics</b> .....	7-36
<b>Injector Supply Lines (High Pressure)</b> .....	6-34	General Information .....	7-36
Clean .....	6-38	<b>Mounting Adaptations - Specifications</b> .....	V-43
General Information .....	6-34	<b>Mounting Adaptations - Torque Values</b> .....	V-44
Initial Check .....	6-36	Engine Support Bracket, Front .....	V-44
Inspect for Reuse .....	6-38	Flywheel .....	V-44
Install .....	6-39	Flywheel Housing .....	V-44
Remove .....	6-36	Flywheel Ring Gear .....	V-44
<b>Injectors and Fuel Lines - Specifications</b> .....	V-21	<b>Newton-Meter to Foot-Pound Conversion Chart</b> .....	V-73
Fuel Drain Line Restriction .....	V-21	<b>Overhead Set</b> .....	3-2
Fuel Inlet Restriction .....	V-21	Adjust .....	3-3
<b>Injectors and Fuel Lines - Torque Values</b> .....	V-22	General Information .....	3-2
AFC Air Tube .....	V-22	<b>Pipe Plug</b> .....	17-3
Fuel Drain Line Restriction .....	V-22	Clean .....	17-4
Fuel Manifold (Drain) .....	V-22	Inspect for Reuse .....	17-4
Fuel Supply Lines .....	V-23	Install .....	17-4
Injector .....	V-23	Remove .....	17-3
Injector Supply Lines (High Pressure) .....	V-23	<b>Pipe Plug Torque Values</b> .....	V-75
<b>Lubricating Oil Contamination</b> .....	7-31	<b>Piston</b> .....	1-78
General Information .....	7-31	Clean .....	1-81
<b>Lubricating Oil Cooler</b> .....	7-8	General Information .....	1-78
Clean .....	7-10	Inspect for Reuse .....	1-82
Install .....	7-10	Install .....	1-86
Preparatory .....	7-8	Preparatory .....	1-79
Pressure Test .....	7-10	Remove .....	1-80
Remove .....	7-9	Test .....	1-83
<b>Lubricating Oil Dipstick</b> .....	7-11	<b>Piston and Connecting Rod Assembly</b> .....	1-95
Calibrate .....	7-11	Assemble .....	1-99
<b>Lubricating Oil Dipstick Tube</b> .....	7-12	Disassemble .....	1-98
Install .....	7-12	General Information .....	1-95
Remove .....	7-12	Install .....	1-103
<b>Lubricating Oil Filter (Spin-On)</b> .....	7-13	Remove .....	1-96
Install .....	7-13	<b>Piston Rings</b> .....	1-86
Remove .....	7-13	General Information .....	1-86
<b>Lubricating Oil Level</b> .....	7-30	Inspect for Reuse .....	1-86
Initial Check .....	7-30	Install .....	1-88
<b>Lubricating Oil Pan</b> .....	7-14	Measure .....	1-87
Clean .....	7-16	<b>Push Rods or Tubes</b> .....	4-2
Drain .....	7-15	Clean .....	4-3
Fill .....	7-18	Inspect for Reuse .....	4-3
General Information .....	7-14	Install .....	4-4
Inspect for Reuse .....	7-17	Preparatory .....	4-2
Install .....	7-17	Remove .....	4-3
Remove .....	7-16	<b>Radiator</b> .....	8-40
<b>Lubricating Oil Pressure Regulator (Main Rifle)</b> .....	7-19	General Information .....	8-40
Clean .....	7-20	Initial Check .....	8-40
Inspect for Reuse .....	7-20	<b>Radiator Hoses</b> .....	8-41
Install .....	7-21	Inspect for Reuse .....	8-41
Preparatory .....	7-19	<b>Radiator Pressure Cap</b> .....	8-41
Remove .....	7-19	General Information .....	8-41
<b>Lubricating Oil Pressure Sensor, OEM</b> .....	7-41	Inspect for Reuse .....	8-42
Inspect for Reuse .....	7-41	Pressure Test .....	8-43

Index  
Page 6

<b>Radiator Shutter Assembly</b> .....	8-43	Clean.....	4-7
General Information .....	8-43	Inspect for Reuse.....	4-7
<b>Rocker Lever</b> .....	3-6	Install.....	4-8
Assemble .....	3-10	Preparatory .....	4-5
Clean .....	3-8	Remove .....	4-5
Disassemble .....	3-7	<b>Timing Pin Housing</b> .....	1-90
Inspect for Reuse.....	3-9	Install.....	1-90
Install.....	3-11	Preparatory .....	1-90
Measure.....	3-9	Remove .....	1-90
Remove .....	3-6	<b>Troubleshooting Procedures and Techniques</b> .....	TS-1
<b>Rocker Lever Cover</b> .....	3-12	<b>Troubleshooting Symptoms Charts</b> .....	TS-2
Clean .....	3-13	Air Compressor Air Pressure Rises Slowly.....	TS-3
Inspect for Reuse.....	3-13	Air Compressor Cycles Frequently.....	TS-4
Install.....	3-13	Air Compressor Noise is Excessive.....	TS-5
Remove .....	3-12	Air Compressor Pumping Excess Lubricating Oil into the Air System.....	TS-7
<b>Rocker Levers - Specifications</b> .....	V-11	Air Compressor Will Not Maintain Adequate Air Pressure (Not Pumping Continuously) .....	TS-9
Overhead Set.....	V-11	Air Compressor Will Not Pump Air .....	TS-10
Rocker Lever.....	V-11	Air Compressor Will Not Stop Pumping .....	TS-11
<b>Rocker Levers - Torque Values</b> .....	V-12	Alternator Not Charging or Insufficient Charging .....	TS-12
Rocker Lever Cover .....	V-12	Alternator Overcharging .....	TS-13
<b>Sea Water Heat Exchanger</b> .....	8-44	Coolant Contamination.....	TS-14
Flush.....	8-44	Coolant in the Lubricating Oil.....	TS-23
<b>Sea Water Pump</b> .....	8-50	Coolant Loss.....	TS-15
Assemble.....	8-53	Coolant Temperature Above Normal – Gradual Overheat.....	TS-17
Clean .....	8-52	Coolant Temperature is Above Normal – Sudden Overheat .....	TS-20
Disassemble .....	8-52	Coolant Temperature is Below Normal.....	TS-22
General Information .....	8-50	Crankcase Gases (Blowby) Excessive .....	TS-24
Inspect .....	8-51	Engine Acceleration or Response Poor .....	TS-25
<b>Service Literature Ordering Location</b> .....	L-2	Engine Difficult to Start or Will Not Start (Exhaust Smoke).. Engine Difficult to Start or Will Not Start (No Exhaust Smoke).....	TS-29 TS-32
<b>Service Tools</b> .....	10-1	Engine Noise Excessive.....	TS-34
Air Intake System .....	10-1	Engine Noise Excessive — Combustion Knocks .....	TS-37
Cam Followers/Tappets.....	4-1	Engine Noise Excessive — Connecting Rod .....	TS-38
Compressed Air System.....	12-1	Engine Noise Excessive — Main Bearing.....	TS-39
Cooling System.....	8-1	Engine Noise Excessive — Piston.....	TS-40
Cylinder Block.....	1-1	Engine Noise Excessive — Turbocharger .....	TS-41
Cylinder Head.....	2-1	Engine Power Output Low.....	TS-42
Electrical Equipment .....	13-1	Engine Runs Rough at Idle.....	TS-46
Engine Disassembly and Assembly.....	0-1	Engine Runs Rough or Misfires .....	TS-48
Engine Testing .....	14-1	Engine Speed Surges at Low or High Idle.....	TS-50
Exhaust System.....	11-1	Engine Starts But Will Not Keep Running .....	TS-52
Fuel System.....	5-1	Engine Vibration Excessive .....	TS-54
Injectors and Fuel Lines.....	6-1	Engine Will Not Crank or Cranks Slowly.....	TS-56
Lubricating Oil System .....	7-1	Engine Will Not Reach High Idle.....	TS-58
Miscellaneous .....	17-1	Engine Will Not Shut Off.....	TS-60
Mounting Adaptations.....	16-1	Excessive Noise .....	TS-61
Rocker Levers.....	3-1	Fuel Consumption Excessive .....	TS-62
<b>Specifications</b> .....	10-7	Fuel in the Lubricating Oil.....	TS-65
Air Intake System .....	10-7, V-53, E-12	Fuel Knock .....	TS-64
Batteries (Specific Gravity) .....	13-10, V-66, E-25	Fuel or Lubricating Oil Leaking From Exhaust Manifold .....	TS-66
Compressed Air System .....	12-7, V-62, E-21	Lubricating Oil Consumption Excessive.....	TS-67
Cooling System .....	8-4, V-51, E-10	Lubricating Oil Contaminated.....	TS-68
Electrical System .....	13-8, V-64, E-23	Lubricating Oil Pressure High .....	TS-69
Engine Testing .....	14-3, V-66, E-25	Lubricating Oil Pressure Low.....	TS-70
Exhaust System .....	11-5, V-60, E-19	Lubricating Oil Sludge in the Crankcase Excessive.....	TS-72
Fuel System .....	5-6, V-47, E-6	Lubricating Oil Temperature Above Specification .....	TS-73
General Specifications .....	V-45, E-4	Lubricating or Transmission Oil in the Coolant .....	TS-74
Lubricating Oil System .....	7-6, V-49, E-8	Smoke, Black — Excessive .....	TS-75
<b>Speed Droop Governor</b> .....	5-94	Smoke, White — Excessive.....	TS-77
Adjust .....	5-94	<b>Turbocharger</b> .....	10-29
<b>Starter Magnetic Switch</b> .....	13-24	Clean .....	10-33
Initial Check.....	13-24	General Information .....	10-29
Resistance Check .....	13-25	Inspect for Reuse .....	10-33
Voltage Check .....	13-26	Install .....	10-35
<b>Starter Solenoid</b> .....	13-28	Measure .....	10-34
Initial Check .....	13-28	Remove .....	10-31
Voltage Check.....	13-29	<b>Turbocharger Axial Clearance</b> .....	10-37
<b>Starter Switch</b> .....	13-27	Measure .....	10-37
Initial Check .....	13-27	<b>Turbocharger Blade Damage</b> .....	10-38
<b>Starting Motor</b> .....	13-34	Inspect for Reuse .....	10-38
Install.....	13-36	<b>Turbocharger Compressor Seal Leaks</b> .....	10-39
Preparatory .....	13-34	Leak Test.....	10-39
Remove.....	13-34	<b>Turbocharger Oil Drain Line</b> .....	10-40
Rotation Check.....	13-37	Clean .....	10-40
Test.....	13-35		
<b>Symbols</b> .....	i-2		
<b>Tap-Drill Chart - U.S. Customary and Metric</b> .....	V-76		
<b>Tappet</b> .....	4-5		

Initial Check .....	10-40
Inspect for Reuse .....	10-40
Install .....	10-41
Remove .....	10-40
<b>Turbocharger Oil Supply Line</b> .....	10-41
Initial Check .....	10-41
Inspect for Reuse .....	10-41
Install .....	10-42
Remove .....	10-41
<b>Turbocharger Radial Bearing Clearance</b> .....	10-42
Measure .....	10-42
<b>Turbocharger Turbine Seal Leaks</b> .....	10-43
Leak Test .....	10-43
<b>Turbocharger Wastegate Actuator</b> .....	10-45
Calibrate .....	10-49
Initial Check .....	10-45
Inspect for Reuse .....	10-47
Install .....	10-48
Remove .....	10-46
Test .....	10-48
<b>Turbocharger Wastegate Valve Body</b> .....	10-50
Inspect for Reuse .....	10-50
<b>Valve, Cylinder Head</b> .....	2-22
Assemble .....	2-26
Clean .....	2-24
Disassemble .....	2-22
Inspect for Reuse .....	2-24
Install .....	2-28
Preparatory .....	2-22
<b>Valve Guide Seal, Cylinder Head</b> .....	2-21
Initial Check .....	2-21
<b>Vibration Damper</b> .....	1-91
General Information .....	1-91
Inspect for Reuse .....	1-92
Install .....	1-94
Measure .....	1-93
Preparatory .....	1-91
Remove .....	1-91
<b>Water Pump</b> .....	8-53
Clean .....	8-54
Inspect for Reuse .....	8-55
Install .....	8-55
Preparatory .....	8-53
Remove .....	8-54
<b>Weights and Measures - Conversion Factors</b> .....	V-77



NO POSTAGE  
NECESSARY  
IF MAILED  
IN THE  
UNITED STATES

**BUSINESS REPLY MAIL**  
FIRST CLASS PERMIT NO. 15, COLUMBUS INDIANA

—POSTAGE WILL BE PAID BY ADDRESSEE—

CUMMINS ENGINE COMPANY, INC.  
MAIL CODE 41302  
BOX 3005  
COLUMBUS, IN 47202-3005



**Do not use this form to order additional literature. Refer to  
Section L - Service Literature for literature information.**

# Literature Survey Form

TM 5-2420-230-24-2

Bulletin No.: 3666087-01

We are always open to any suggestions or recommendations that will aid in improving our manuals. Use this postage paid survey form to evaluate this manual. Please check the appropriate response and use the space provided below to list any additional comments:

	Yes	No
Is the needed information easy to locate in the manual?	_____	_____
Is the information easy to read?	_____	_____
Is the information easy to understand?	_____	_____
Does the information sufficiently cover the subject?	_____	_____
Are subjects in the Index specific enough to locate in the manual?	_____	_____
Are the important points sufficiently emphasized?	_____	_____
Are the illustrations easy to understand?	_____	_____
Does the text support the operation being illustrated?	_____	_____
Do you use the Table of Contents and Section Contents?	_____	_____
Do you use the Index?	_____	_____

Please provide comments on any response(s) marked "No" in this survey and on any suggestions you feel could improve our manuals. \_\_\_\_\_

\_\_\_\_\_

\_\_\_\_\_

\_\_\_\_\_

\_\_\_\_\_

Name: \_\_\_\_\_

Company: \_\_\_\_\_

Street Address: \_\_\_\_\_

City: \_\_\_\_\_ State/Province: \_\_\_\_\_

Country: \_\_\_\_\_ Zip/Postal Code: \_\_\_\_\_

**Do not use this form to order additional literature. Refer to Section L - Service Literature for literature information.**

**Cummins Engine Company, Inc.**  
Box 3005  
Columbus, Indiana, U.S.A., 47202

Registered Office  
**Cummins Engine Company, Ltd.**  
46-50 Coombe Road  
New Malden,  
Surrey KT3 4QL,  
England  
Registration No. 573951 England

Copyright© 1999  
Cummins Engine Company, Inc.



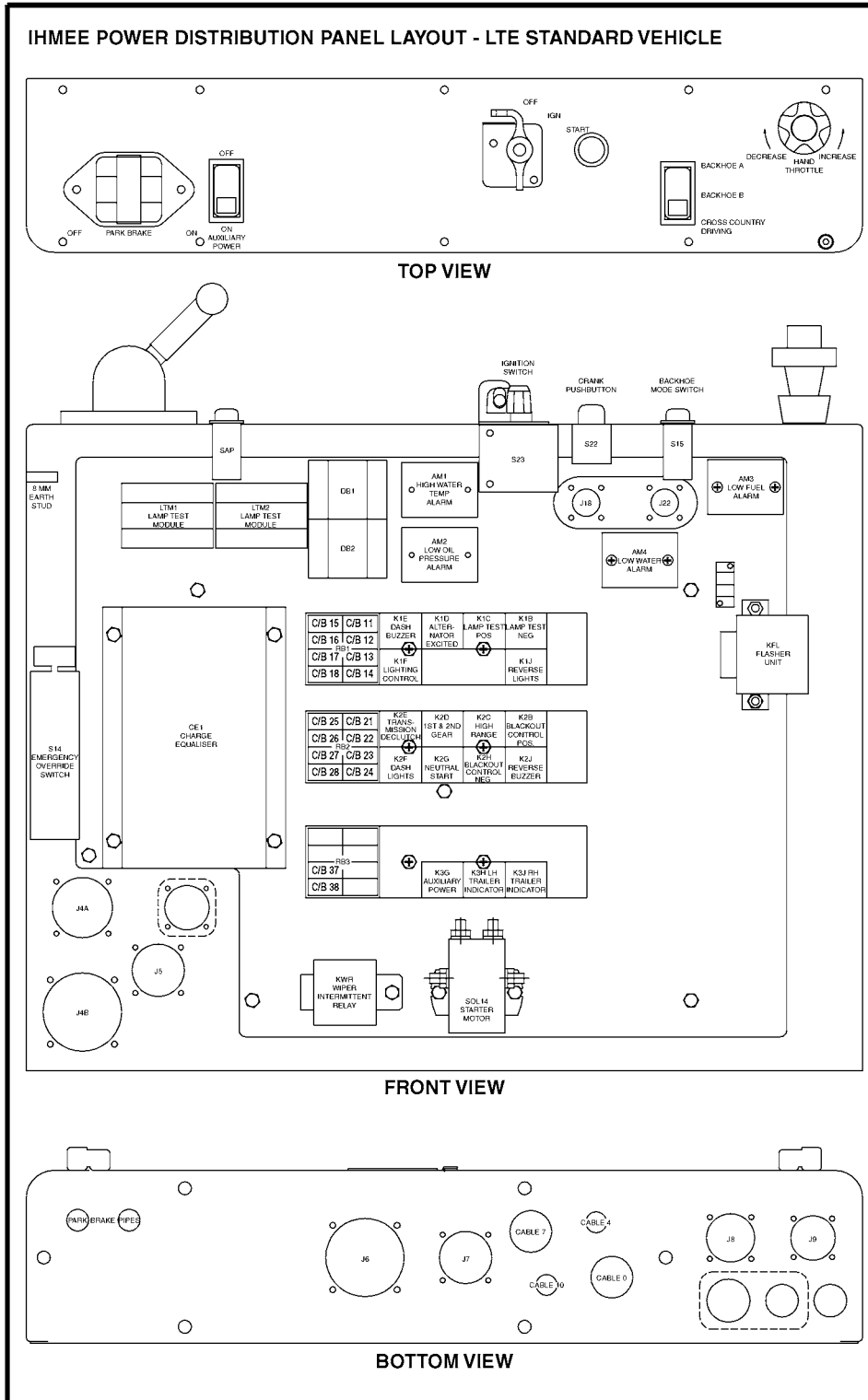

ME0578

FO-1. Power Distribution Panel Layout.

FP-1/FP-2 blank



**ELECTRICAL SCHEMATIC**

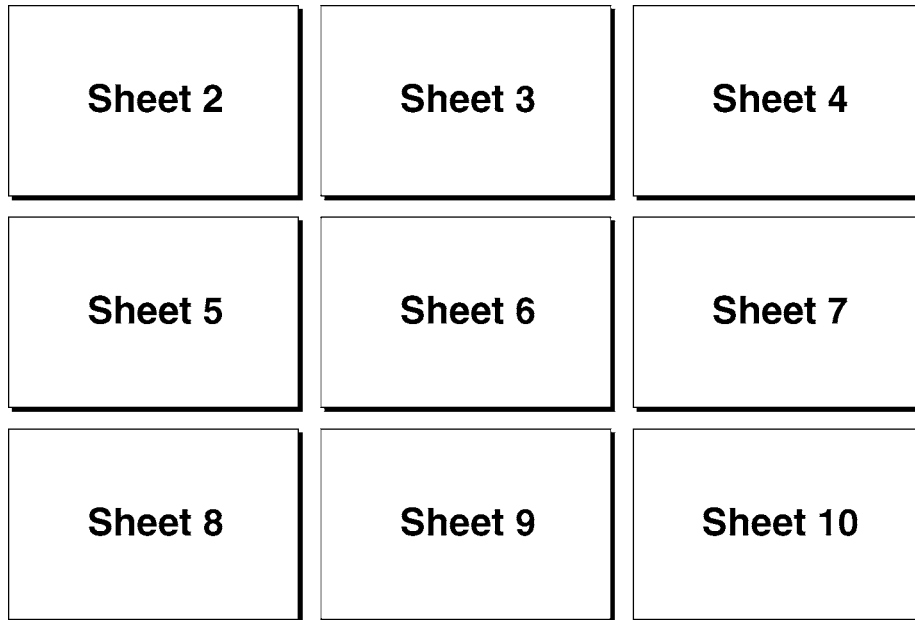

**THIS ORGANIZATIONAL RELATIONSHIP OF SCHEMATICS IS  
PROVIDED FOR REFERENCE**

ME1206

**FO-2. Power Distribution Panel Diagram (sheet 1 of 10).**

**FP-3/FP-4 blank**



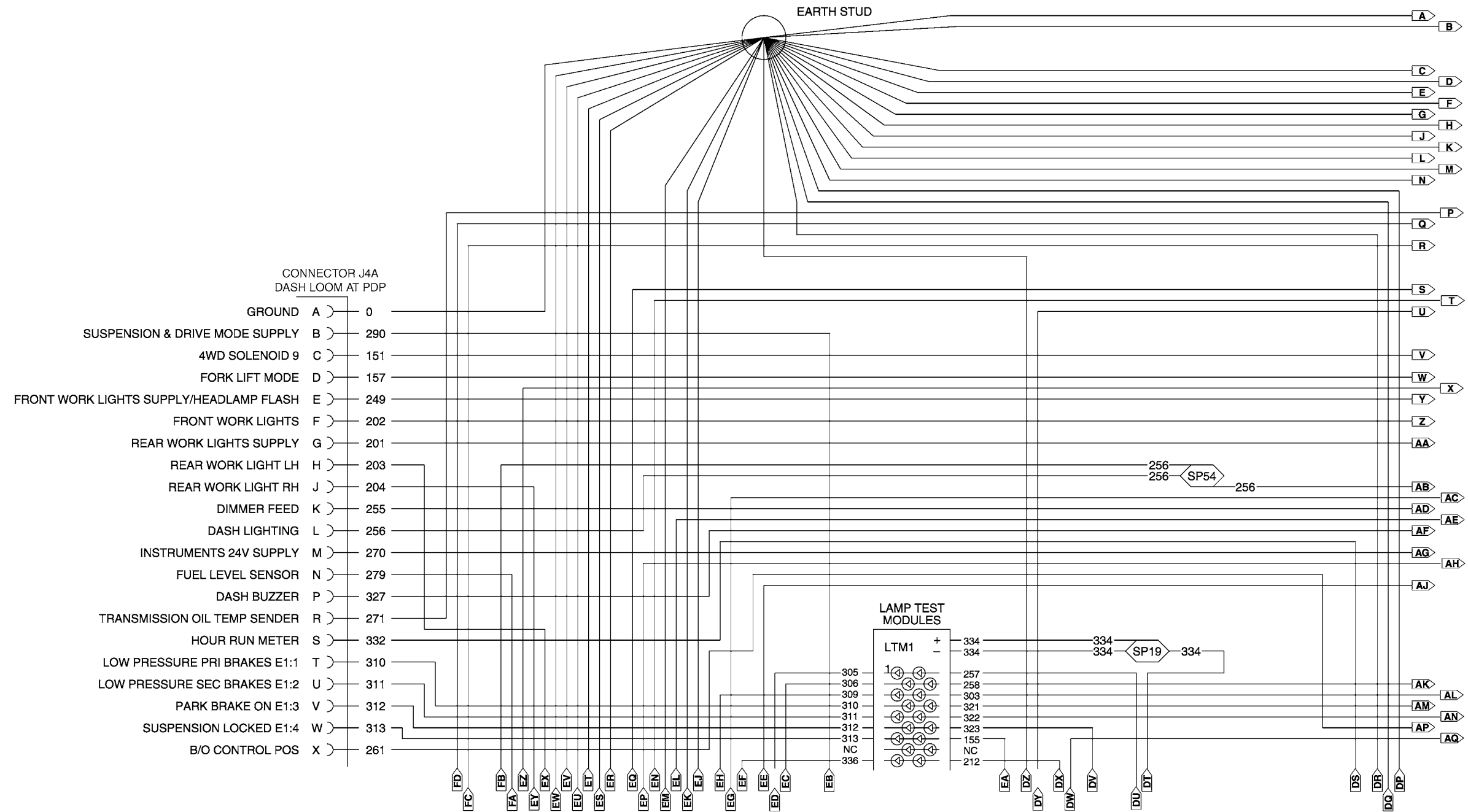



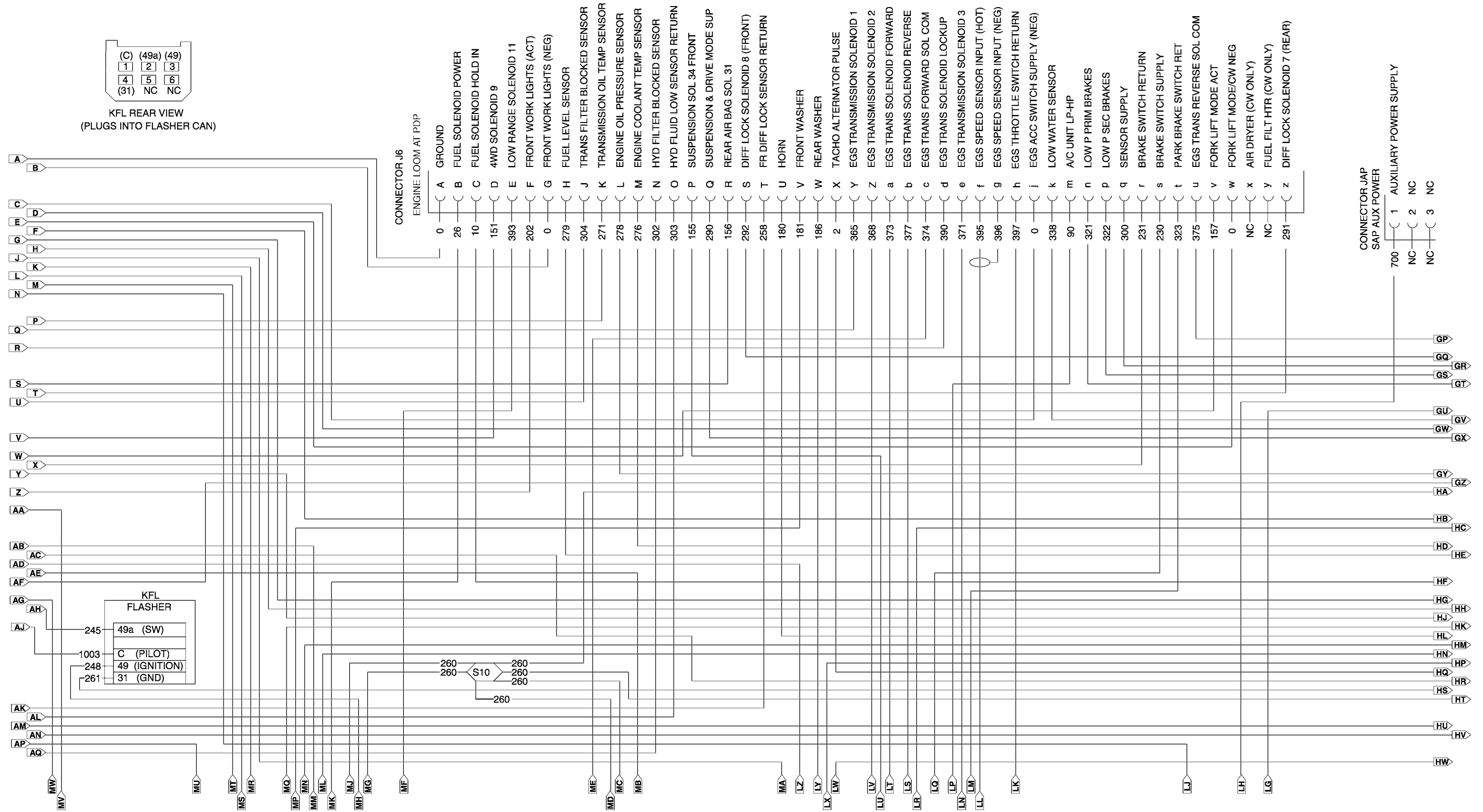
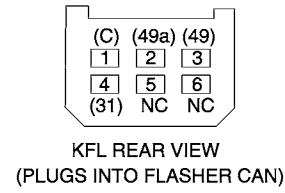

ME1146





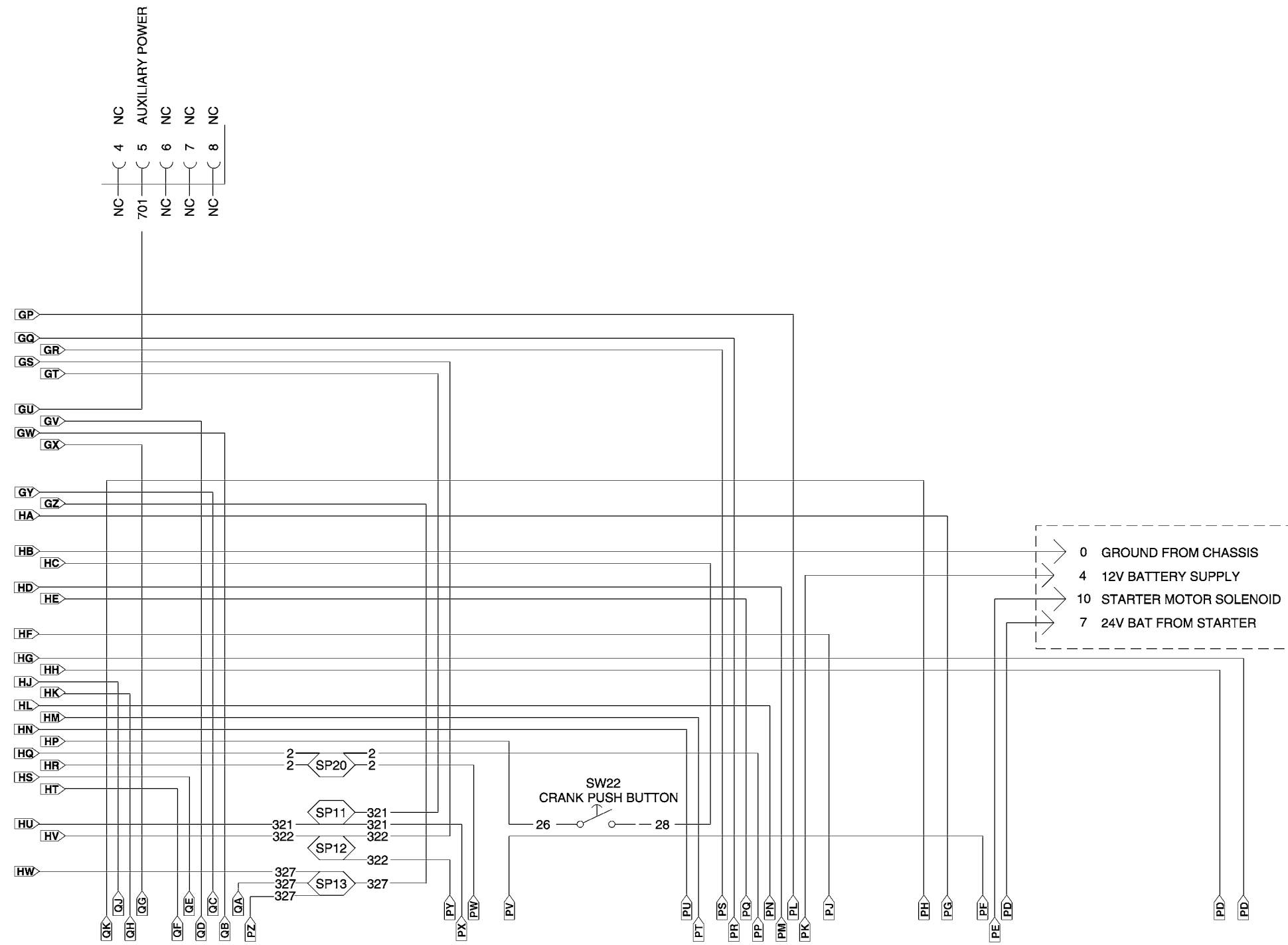



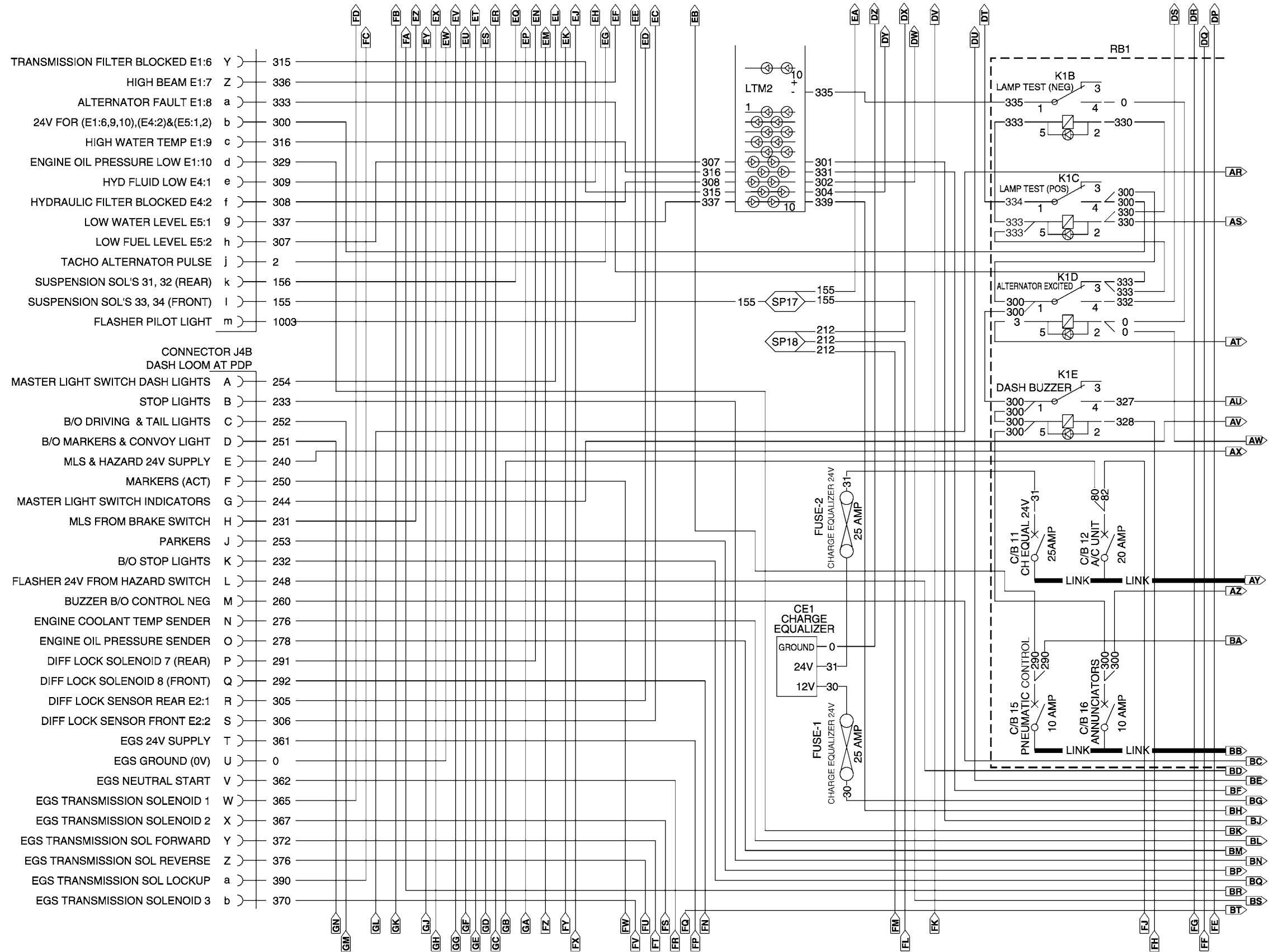

FO-2. Power Distribution Panel Diagram (sheet 5 of 10).

ME1144



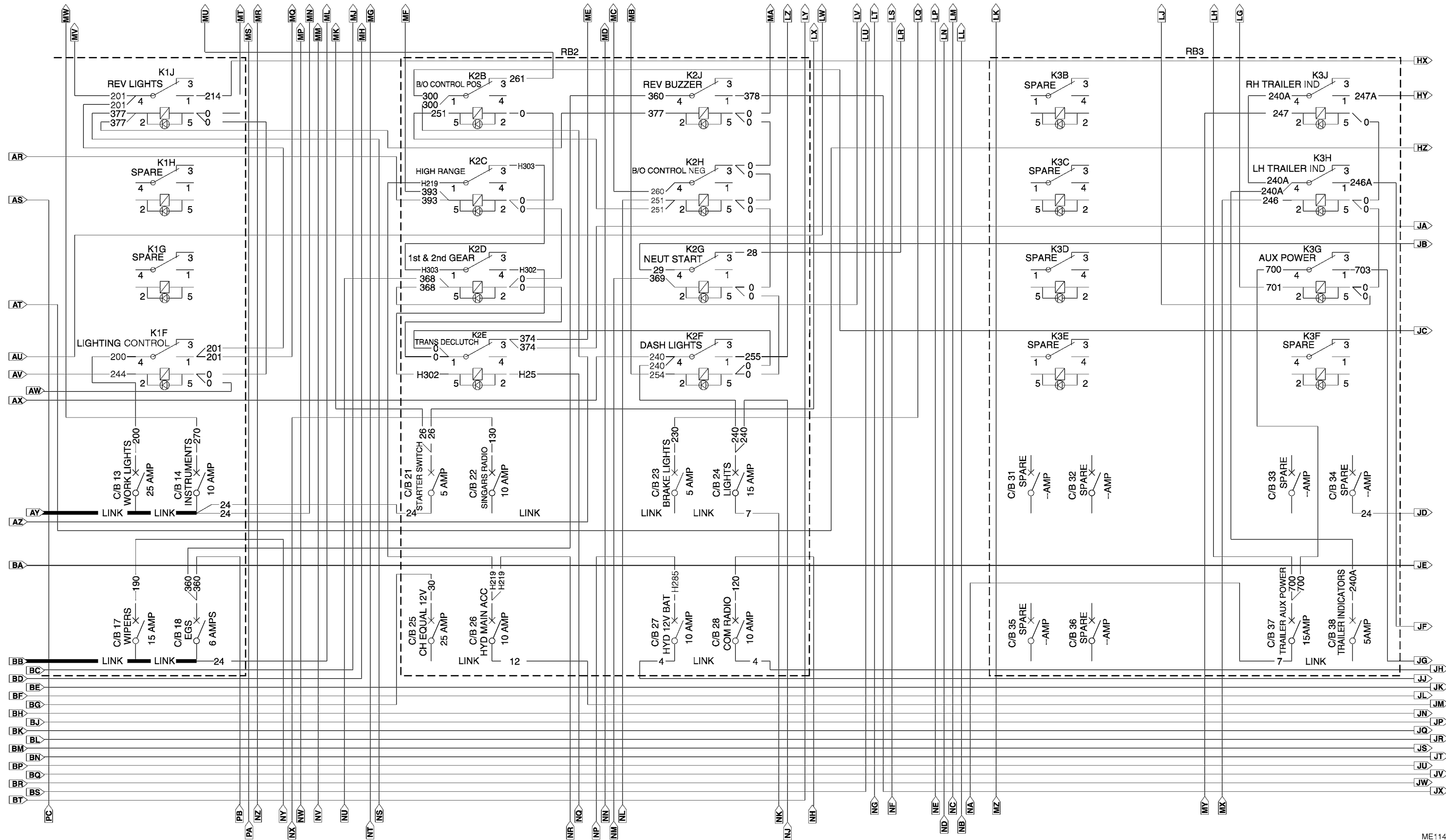

FO-2. Power Distribution Panel Diagram (sheet 6 of 10).

ME1147



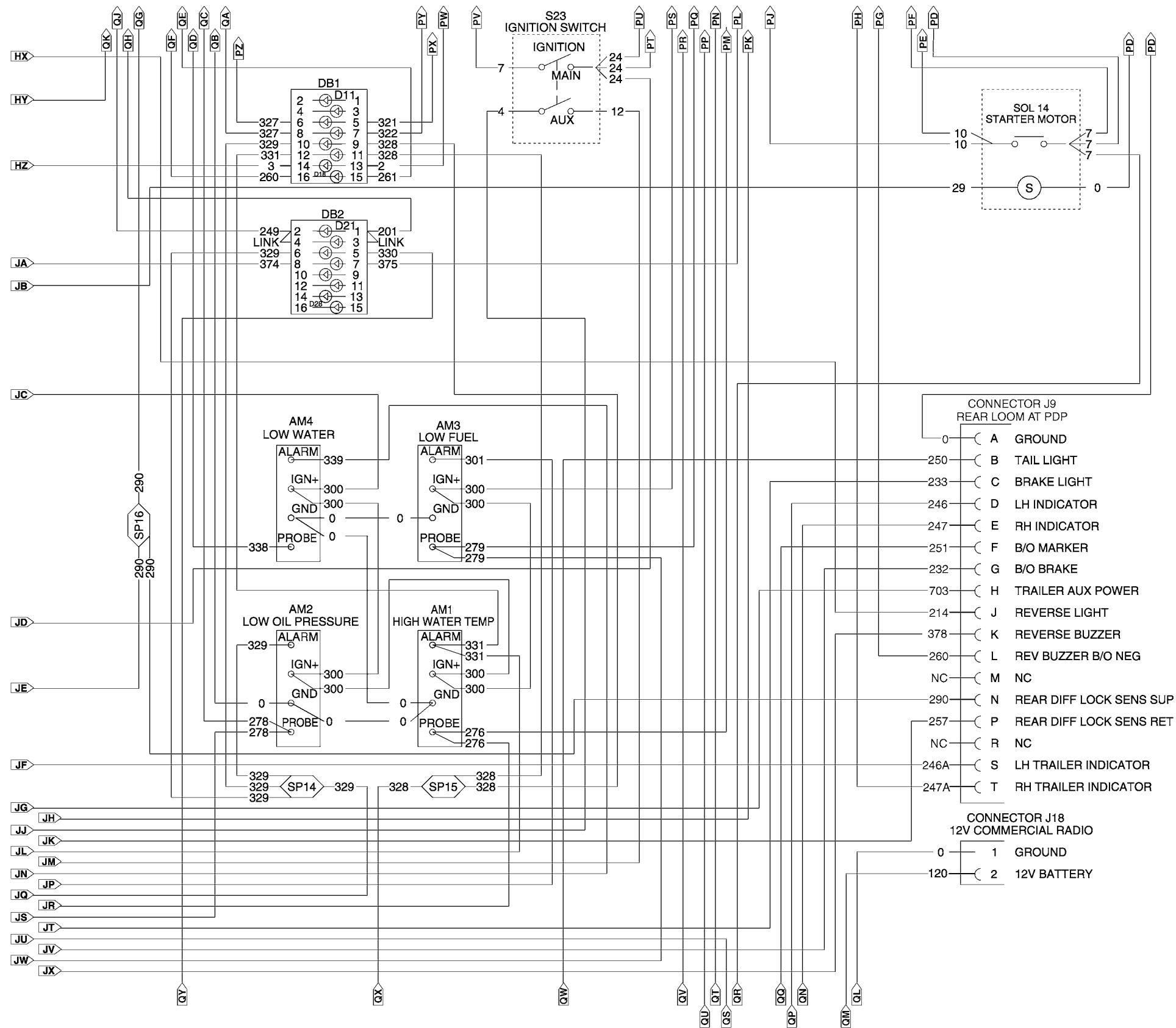

FO-2. Power Distribution Panel Diagram (sheet 7 of 10).





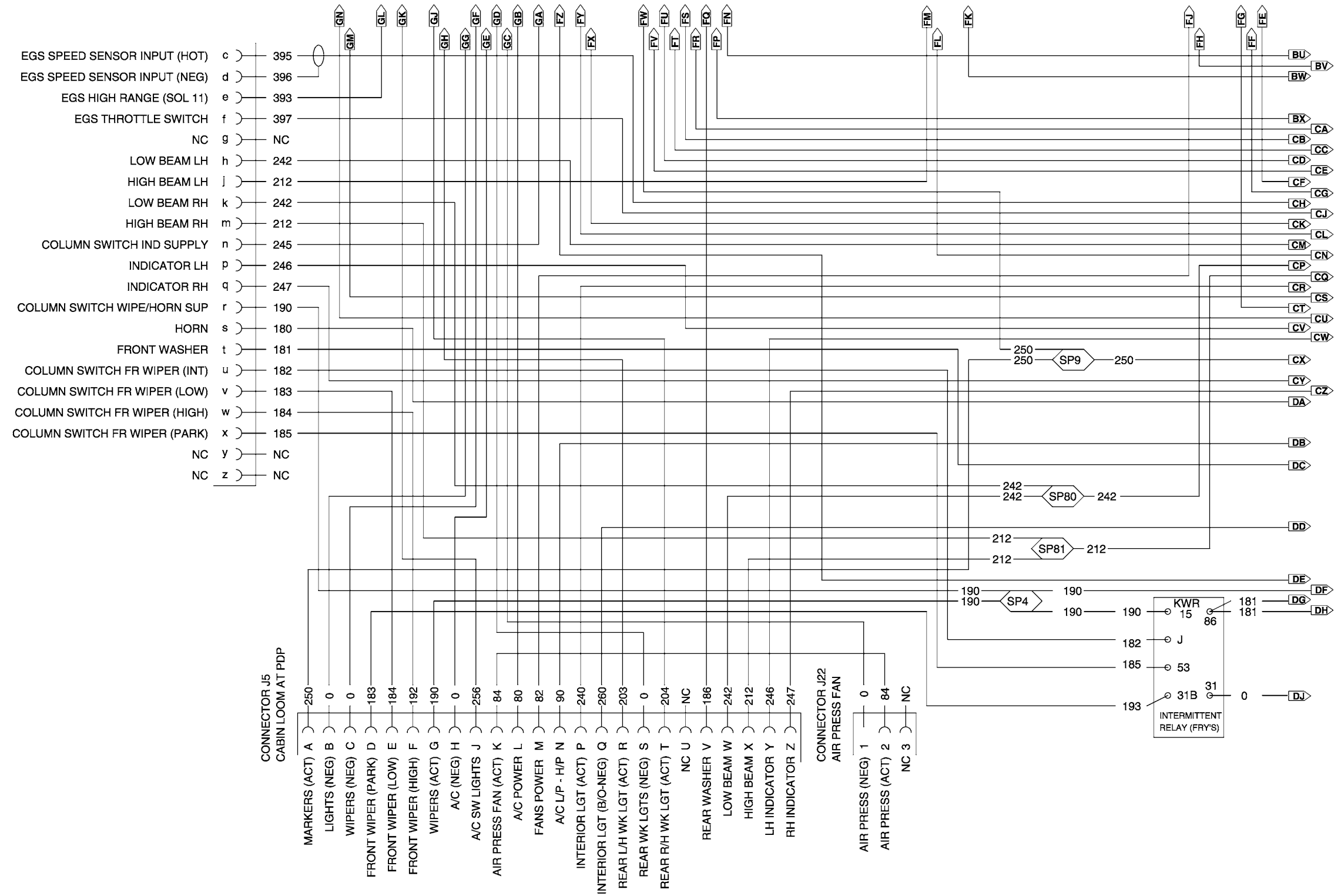



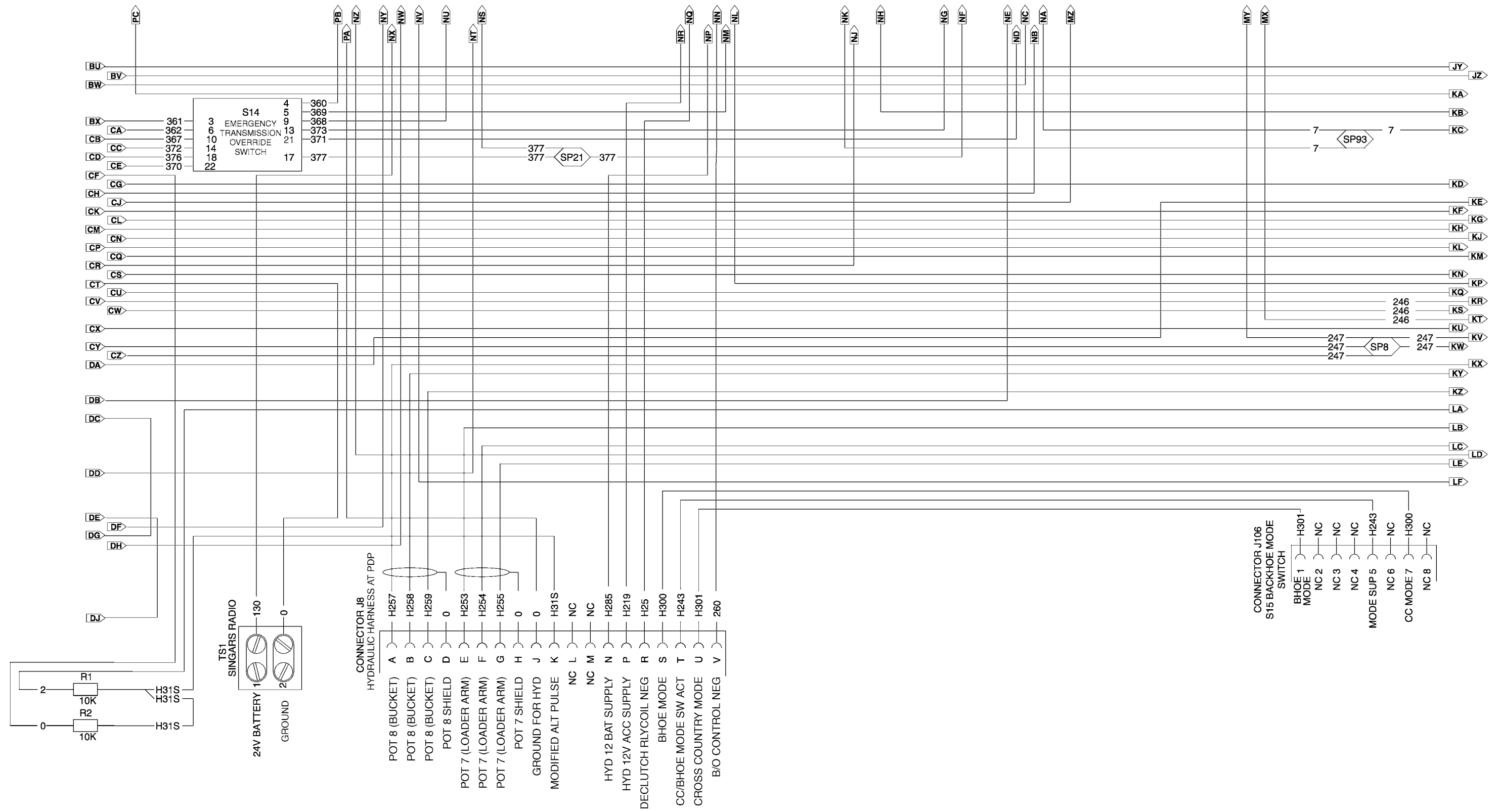

ME1148



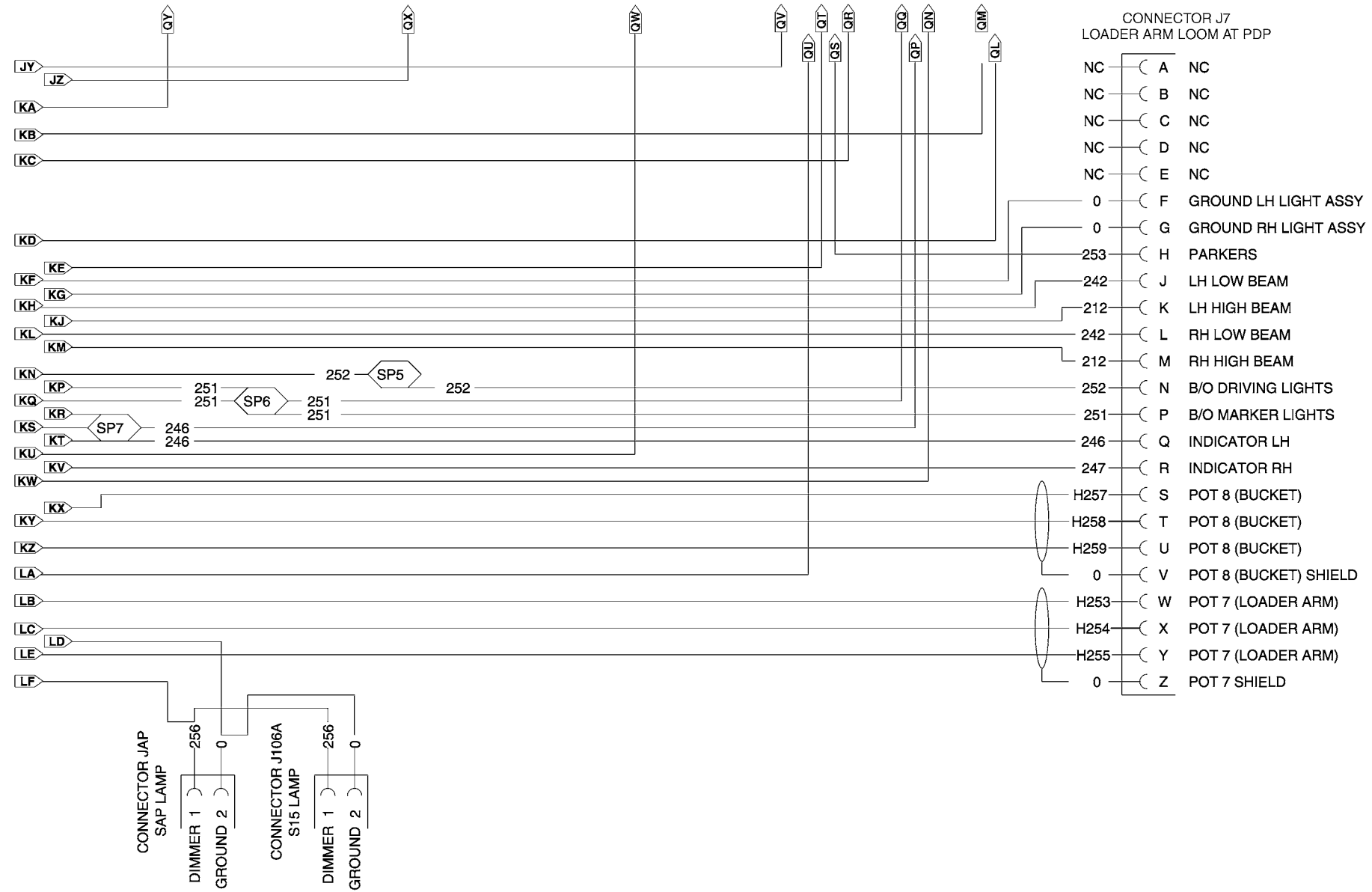



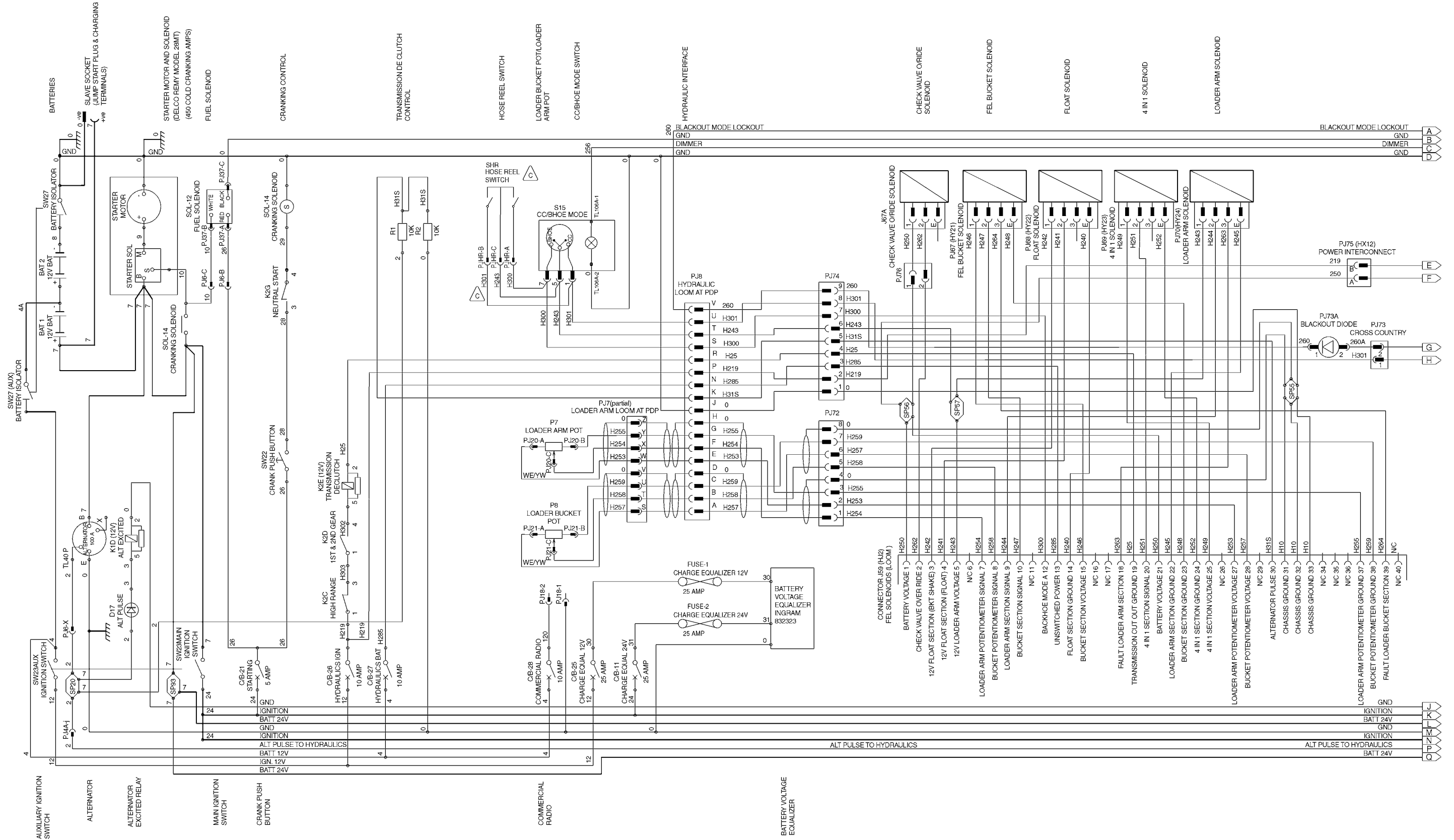

FO-3. Electric Diagram (sheet 1 of 7).

ME0219





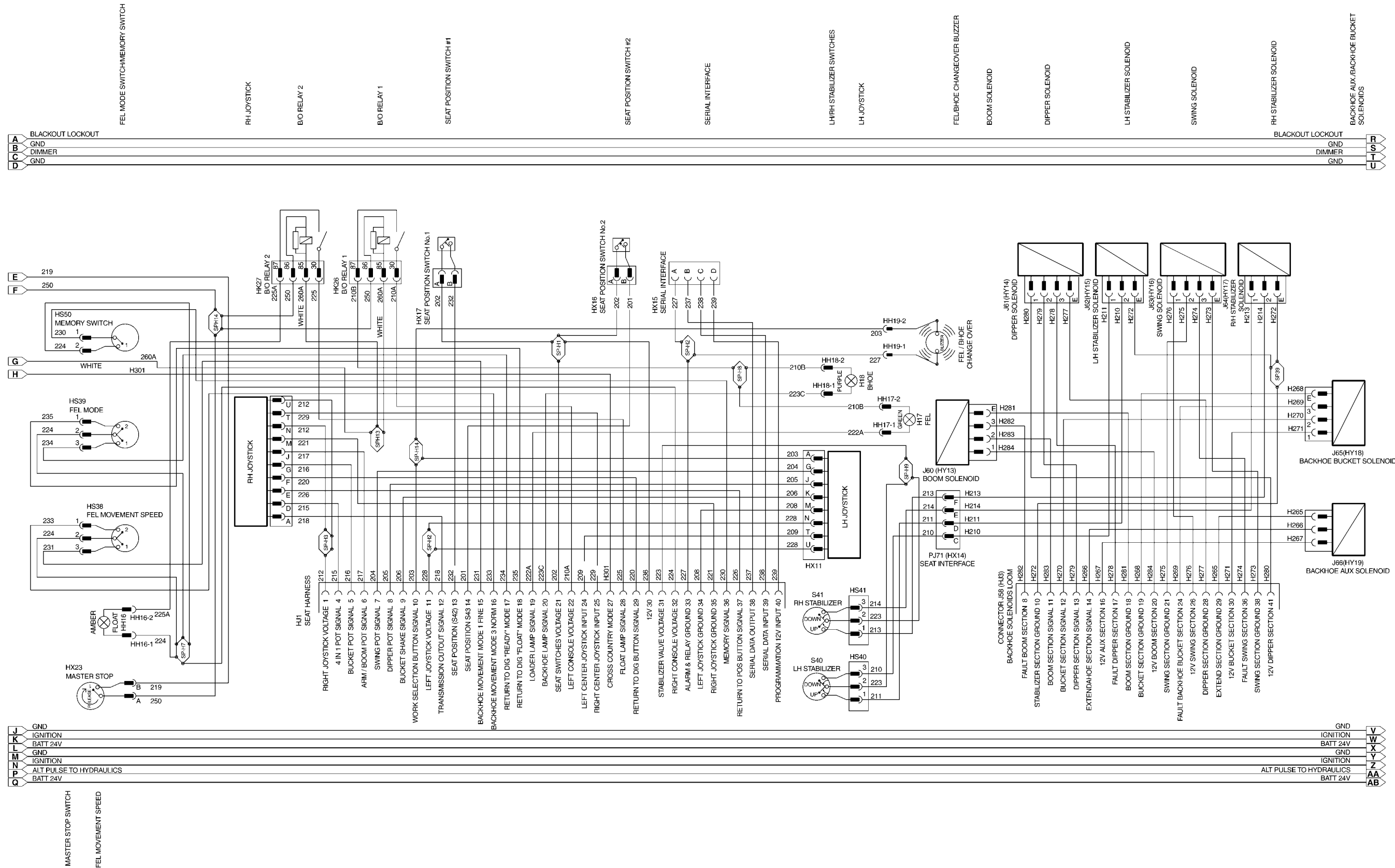

FO-3. Electric Diagram (sheet 2 of 7).



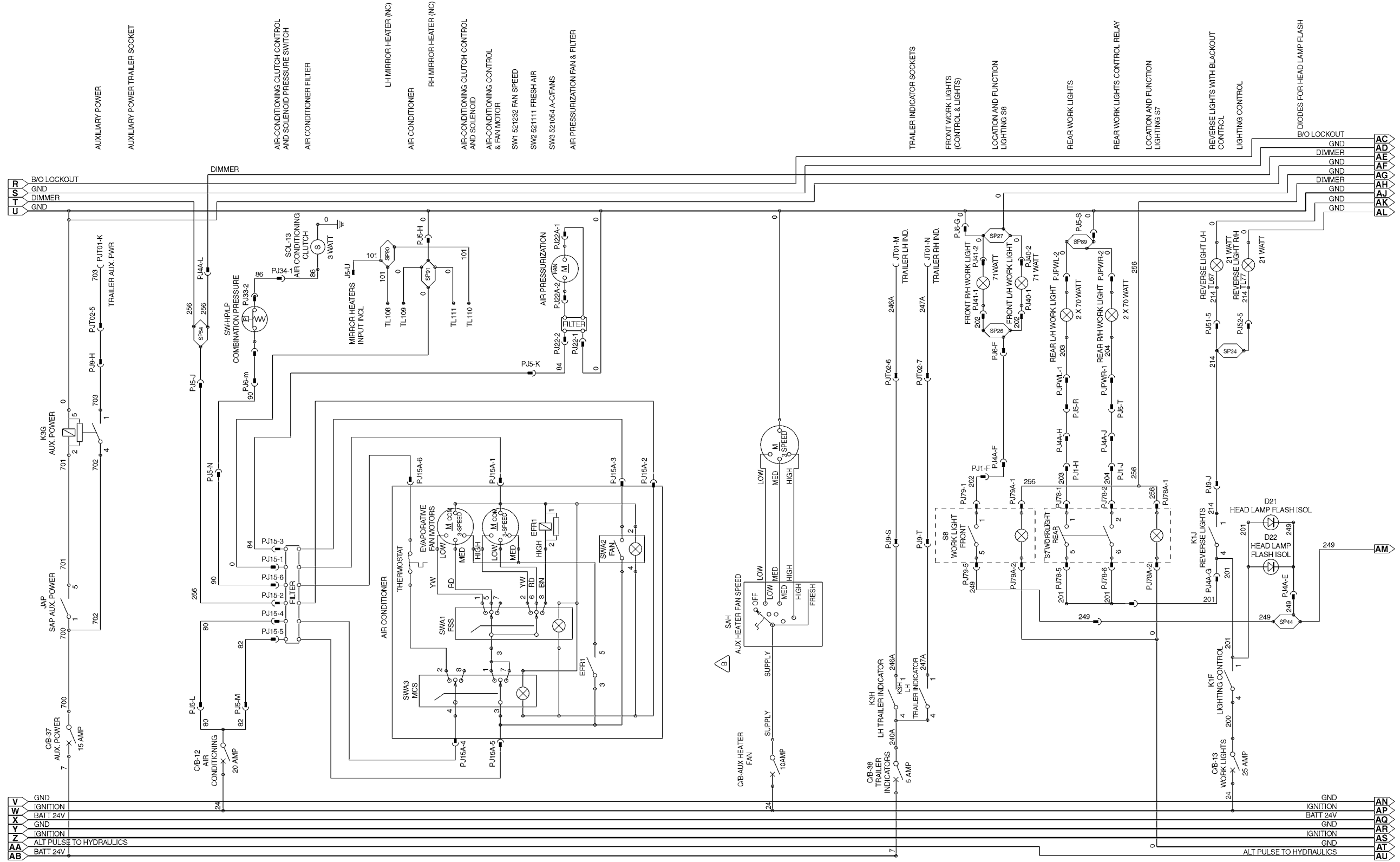

ME0225  
**FO-3. Electric Diagram (sheet 3 of 7).**  
 FP-27/FP-28 blank  
 Change 1



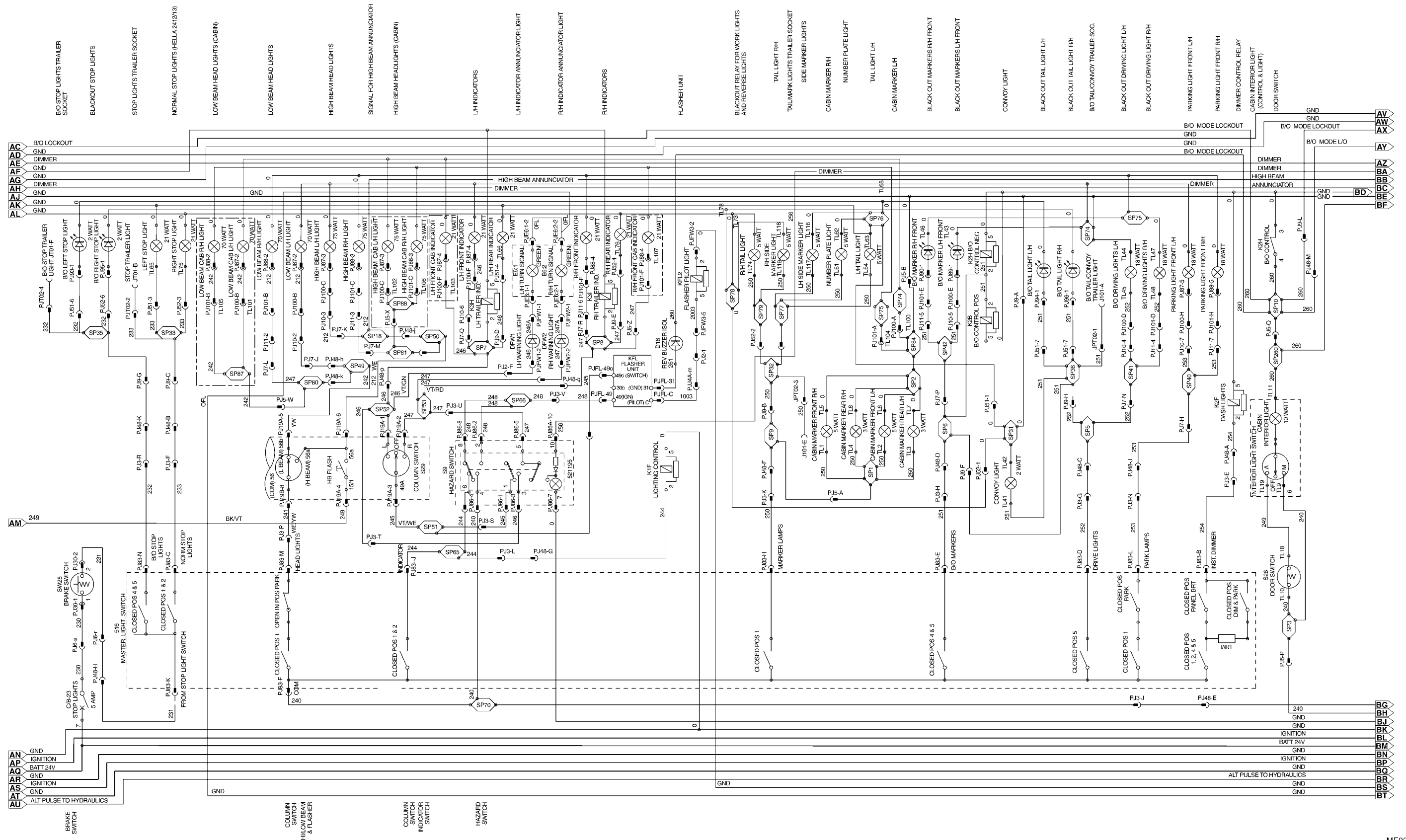

FO-3. Electric Diagram (sheet 4 of 7).

ME0226



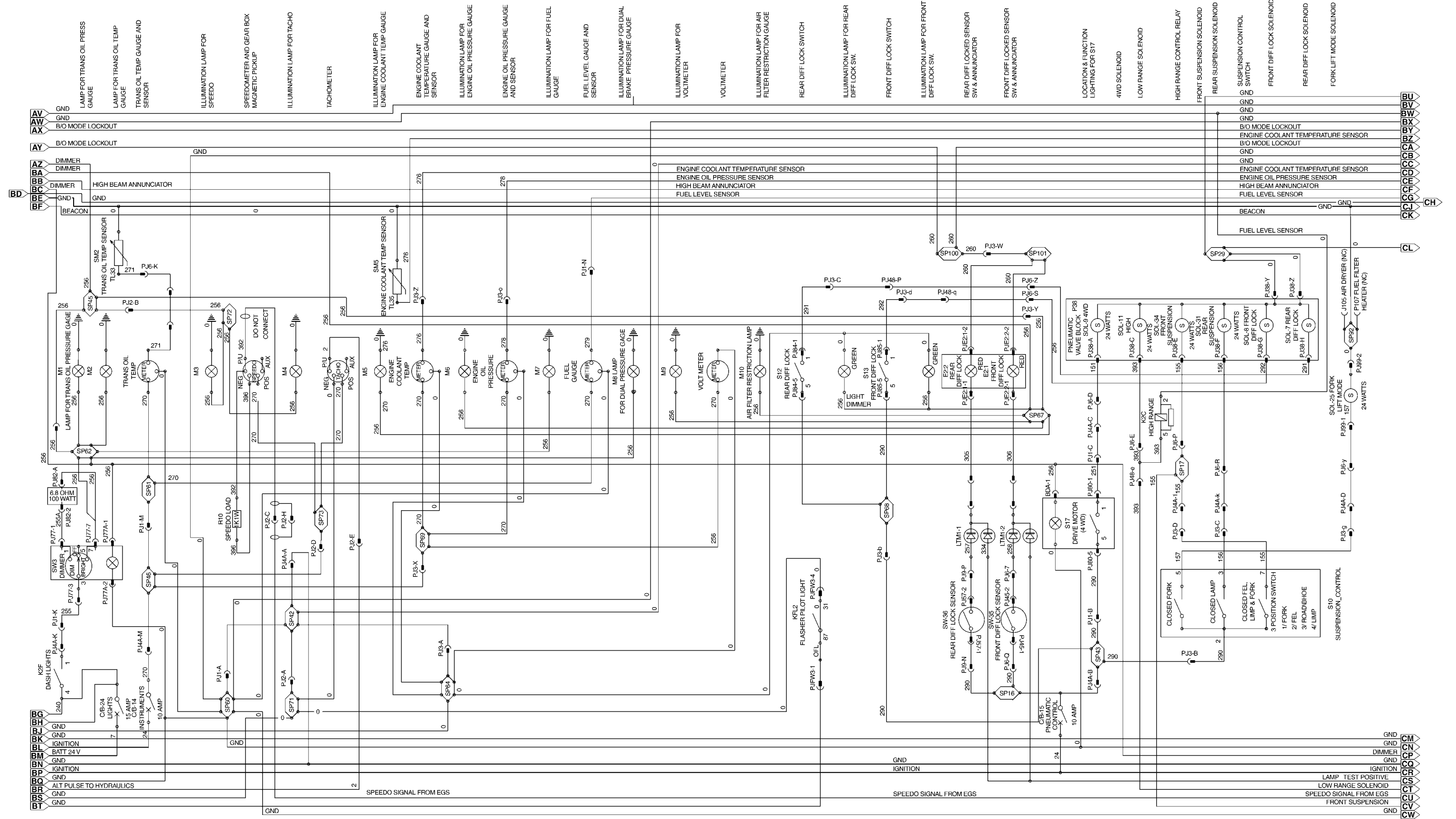

ME0227

FO-3. Electric Diagram (sheet 5 of 7).  
FP-31/FP-32 blank  
Change 1









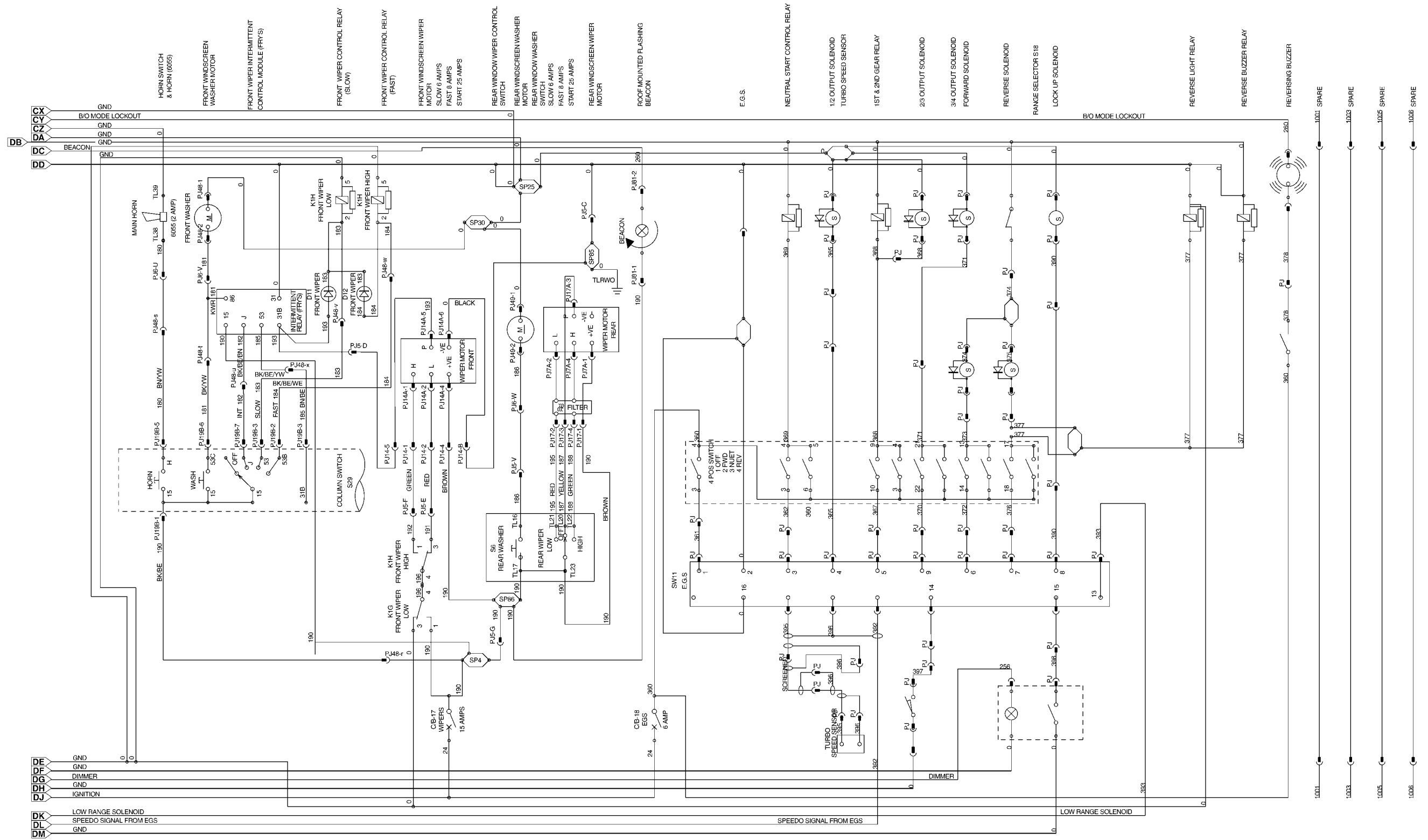

FO-3. Electric Diagram (sheet 7 of 7).

FP-35/FP-36 blank  
Change 1

ME0229



NOTES:

- 1. MAIN SYSTEM PRESSURE IS 207 BAR. ( 3000 PSI )
- 2. FAN DRIVE SYSTEM PRESSURE IS 220 BAR. ( 3200 PSI )

**H** 3 THE HOSE REEL OPTION MUST USE HYDRAULIC CONTROLLER PART NUMBER LTA-V12-004-002.

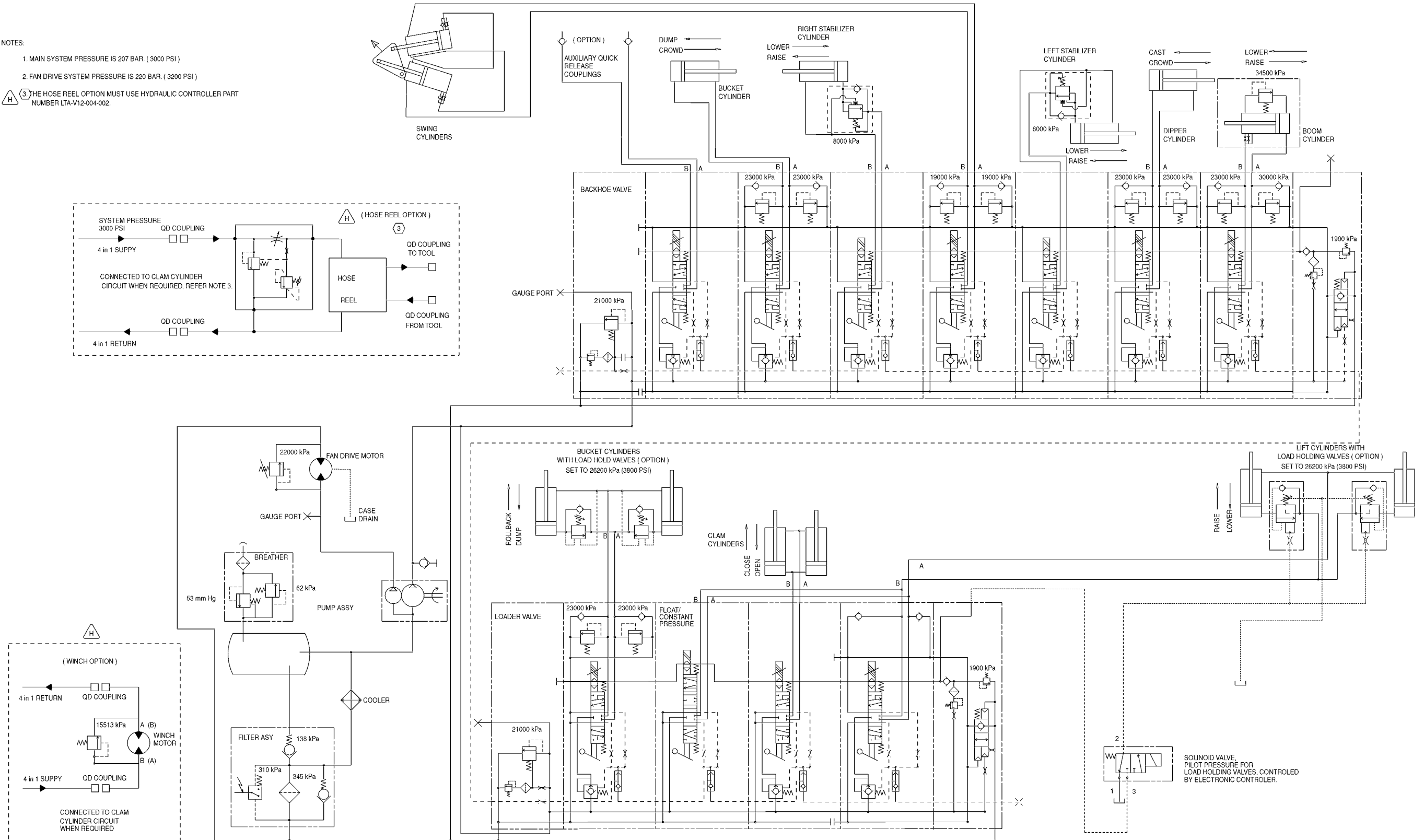

ME0217



NOTES:

1. SYSTEM PRESSURE 114.6-117.5 PSI (7.9-8.1 BAR)

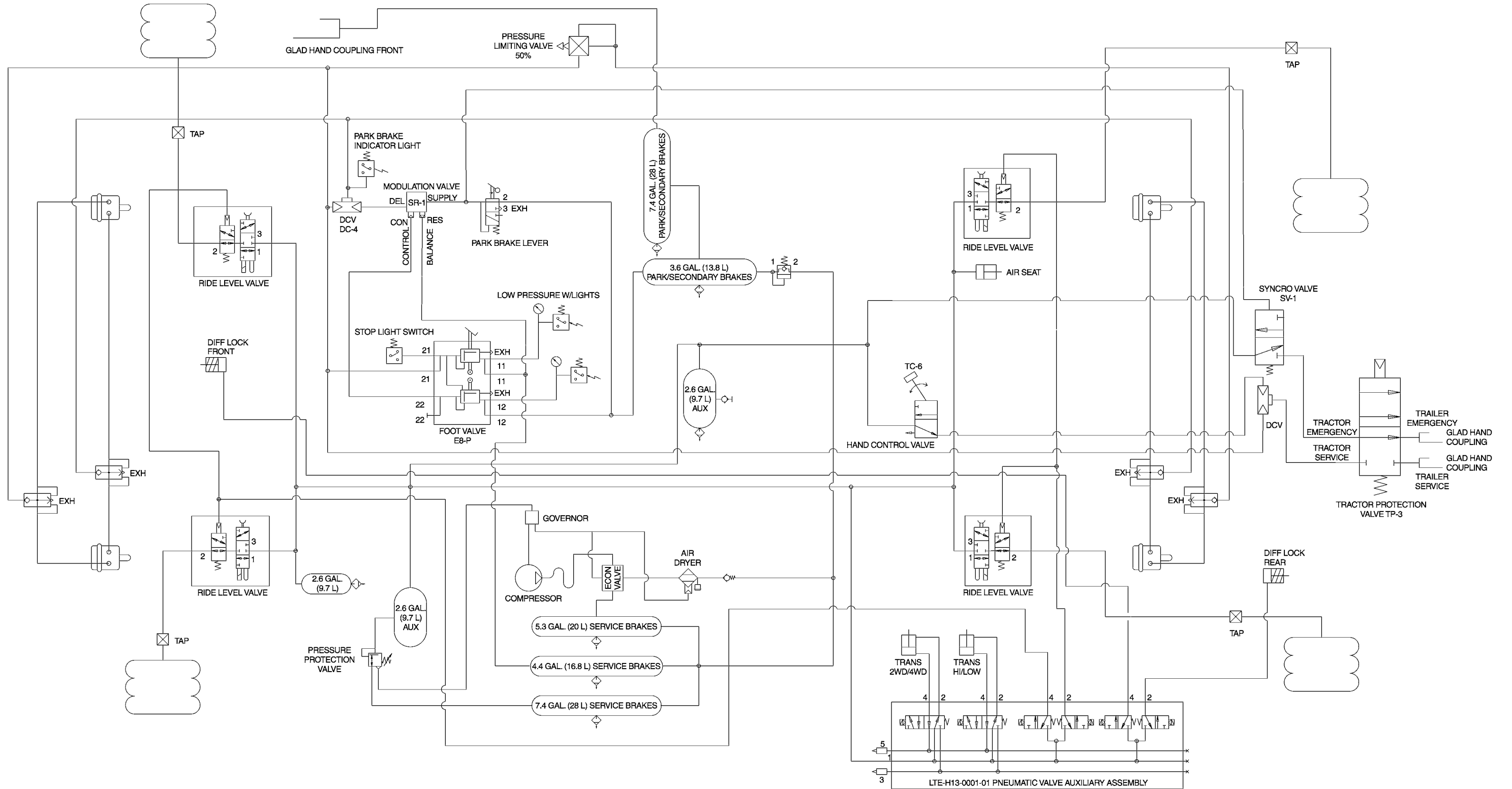





## ALPHABETICAL INDEX

<u>Subject</u>	<u>Page</u>
<b>Numerics</b>	
1st Speed Clutch (Low) Repair.....	F-5
4-in-1 Bucket Cylinder Maintenance.....	10-54
4-in-1 Bucket Repair.....	17-15
4th Speed Clutch Repair.....	F-18
8-Speed Output Repair.....	F-16
<b>A</b>	
A/C Compressor Replacement.....	19-15
A/C Condenser Replacement.....	19-14
A/C Cover Replacement.....	19-11
A/C Evaporator Assembly Maintenance.....	19-19
A/C Filter Replacement.....	13-56
A/C Precleaner Replacement.....	13-58
A/C Pressurizer Replacement.....	19-12
A/C Receiver-Drier Replacement.....	19-18
A/C System Servicing.....	19-3
Accelerator Pedal Replacement.....	13-2
ADI-Recommended Torque Tables.....	E-3
Aftercooler Replacement.....	L-19
Air Chamber Replacement, Front Axle.....	J-10
Air Chamber Replacement, Rear Axle.....	J-16
Air Cleaner Filter Replacement.....	13-54
Air Cleaner/Stowage Box Repair.....	13-59
Air Compressor Replacement.....	15-15
Air Drier Desiccant Replacement.....	15-18
Air Drier Replacement.....	15-16
Air Governor Replacement.....	15-13
Air Line Replacement.....	15-12
Air Tank Replacement.....	15-5
Air Valve Replacement.....	15-4
Airbag Replacement.....	6-4
Alarm Module Replacement.....	12-27
Alternator Replacement.....	12-13
Alternator Testing.....	12-3
Arctic Heater Assembly Maintenance.....	20-18
Army Maintenance System MAC, The.....	B-1
Army Publications Web Sites.....	A-2
Auxiliary Defroster Ducting Replacement.....	13-71
Auxiliary Defroster Heater Maintenance.....	13-73
Auxiliary Defroster Switch Replacement.....	12-25

<u>Subject</u>	<u>Page</u>
Auxiliary Hydraulics Backhoe Flow Rates.....	3-37
Axle Assembly Replacement, Front .....	14-9
Axle Assembly Replacement, Rear .....	14-11
Axle Housing Breather Replacement.....	14-13
Axle Hub and Differential Oil Servicing.....	14-2
Axle Stop Adjustment.....	K-3

**B**

Backhoe Valve Block Maintenance.....	10-27
Battery Cable Replacement.....	12-7
Battery Equalizer Testing. ....	12-4
Battery Explosions.....	2-13
Battery Replacement.....	12-5
Battery Stowage Box Maintenance.....	13-48
Battery Trickle Charger Replacement .....	20-55
Belt Tensioner Replacement, Engine.....	L-10
Bleeding Fuel System. ....	7-2
Bleeding Single Gear System. ....	K-2
Boom Cylinder Maintenance.....	10-36
Boom Hydraulic Cylinder Repair .....	H-8.2
Boom Lock Pedal and Cable Replacement.....	13-5
Boom Replacement.....	H-4
Brake Assembly Repair, Front Axle.....	J-4
Brake Control Valve Replacement. ....	15-10
Brake Drum Replacement.....	8-4
Brake Shoe Replacement, Front .....	J-5
Brake Shoe Replacement, Rear.....	J-13
Breather Replacement, Axle Housing.....	14-13
Breather Replacement, Front Axle Hub.....	14-15
Breather Replacement, Fuel Tank.....	7-6
Bucket and Dipper Hydraulic Cylinder Repair.....	H-8
Bucket Cylinder Maintenance.....	10-33
Bump Stop Replacement. ....	6-7
Bushing Replacement, General.....	17-13

**C**

Caging, Spring Brake Chamber .....	8-10
Camshaft Gear Replacement, Engine .....	L-50
Camshaft Replacement. ....	L-39
Carbon Monoxide Hazard.....	2-16
Charge Equalizer Replacement.....	12-37
Charging Pump Replacement. ....	4-38
Check Strap Replacement.....	6-2

<b><u>Subject</u></b>	<b><u>Page</u></b>
Cleanliness.....	2-11
Cold Weather Kit Initial Installation .....	20-3
Cold Weather Kit.....	1-11
Combustion Air Blower Replacement.....	20-26
Control Arm Replacement.....	6-12
Control Unit Replacement .....	20-28
Coolant Reservoir Replacement. ....	9-11
Cooling System Servicing. ....	9-2
Crankshaft Gear Replacement, Engine.....	L-49
Crankshaft Pulley/Vibration Damper Replacement (Engine).....	L-9
Crankshaft Replacement.....	L-46
Crush Hazard. ....	2-14
Cutting Edge Replacement. ....	17-12
Cylinder Block Repair. ....	L-47
Cylinder Head Repair. ....	L-51
Cylinder Head Maintenance. ....	L-25
Cylinder Maintenance, 4-In-1 Bucket .....	10-54
Cylinder Maintenance, Boom.....	10-36
Cylinder Maintenance, Bucket .....	10-33
Cylinder Maintenance, Dipper.....	10-39
Cylinder Maintenance, Tilt.....	10-50
Cylinder Replacement, FEL Lift .....	10-47
Cylinder Replacement, Stabilizer .....	10-44
Cylinder Replacement, Swing .....	10-42

**D**

Dash Panel Wiring Harness Replacement.....	12-85
Data Plate Replacement.....	13-20
Destruction of Army Material to Prevent Enemy Use.....	1-2
Differential Assembly Repair, Front .....	J-9
Differential Assembly Repair, Rear.....	J-15
Dipper Cylinder Maintenance.....	10-39
Dipper Replacement. ....	H-6
Dipstick Replacement, Engine.....	L-18
Disposal of Waste. ....	2-15
Door Assembly Replacement. ....	13-63
Door Gas Strut Replacement. ....	13-69
Door Handle Replacement.....	13-67
Door Hinge Replacement.....	13-66
Drag Link Replacement.....	5-34
Draining Air System. ....	15-2
Drive Belt Replacement.....	4-6
Drive Head Replacement, Front Axle.....	J-8
Drive Head Replacement, Rear Axle.....	J-14

<u>Subject</u>	<u>Page</u>
Drive Plate Installation .....	F-21
Drive Shaft and U-Joint Maintenance.....	14-5
 <b>E</b> 	
EGS Self-Test Function .....	G-2
Electrical Master Switch Replacement .....	12-9
Electrical Outlet Replacement .....	20-58
Electrical System .....	1-7
Electromagnetic Interference.....	2-15
Electronic Control Unit (ECU) Replacement .....	12-66
Electronic Gear Shift (EGS) Replacement .....	12-46
Engine Block Heater Replacement .....	20-53
Engine Component Replacement.....	4-22
Engine Hood Maintenance.....	13-32
Engine Mount Replacement.....	4-48
Engine Mounting .....	L-5
Engine Oil Sampling Valve Assembly Replacement .....	4-42
Engine Oil Service and Filter Replacement.....	4-2
Engine Repair (Belt Tensioner Replacement) .....	L-10
Engine Repair (Camshaft Gear Replacement).....	L-50
Engine Repair (Crankshaft Gear Replacement).....	L-49
Engine Repair (Dipstick Replacement) .....	L-18
Engine Repair (Fan Hub Maintenance) .....	L-55
Engine Repair (Fan Hub Replacement) .....	L-11
Engine Repair (Fan Pulley Replacement).....	L-8
Engine Repair (Front Cover Replacement).....	L-27
Engine Repair (Fuel Lines Replacement).....	L-16
Engine Repair (Gear Housing Replacement).....	L-43
Engine Repair (Mechanical Tachometer Drive Cover Replacement) .....	L-57
Engine Repair (Push Rods Replacement).....	L-24
Engine Repair (Rear Lifting Bracket Replacement).....	L-7
Engine Repair (Rear Seal Housing Replacement).....	L-38
Engine Repair (Rocker Lever Repair) .....	L-53
Engine Repair (Rocker Levers Replacement).....	L-23
Engine Repair (Tappet Cover Replacement).....	L-33
Engine Repair (Thermostat Replacement).....	L-12
Engine Repair (Turbocharger Mounting Stud Replacement) .....	L-56
Engine Repair (Valve Tappets Replacement).....	L-41
Engine Repair (Vibration Damper/Crankshaft Pulley Replacement).....	L-9
Engine Repair (Water Inlet Connection Replacement) .....	L-35
Engine Repair .....	L-3
Engine System .....	1-6
Equipment Characteristics, Capabilities, and Features.....	1-4

<u>Subject</u>	<u>Page</u>
Equipment Improvement Report and Maintenance Digest (EIR MD) and Equipment Improvement Report and Maintenance Summary (EIR MS).....	1-3
Ether Start Assembly Replacement .....	20-44
Ether Start Pushbutton Replacement .....	20-47
Ether Start Thermostat Replacement .....	20-51
Exhaust Manifold Replacement.....	L-15
Exhaust Pipes Replacement.....	11-5
Expendable and Durable Items .....	C-2
Explanation of Columns in Remarks, Section IV.....	B-3
Explanation of Columns in the MAC, Section II.....	B-2

**F**

Explanation of Columns in Tool and Test Equipment Requirements, Section III. ....	B-3
Fan and Hydraulic Motor Maintenance.....	9-6
Fan Hub Maintenance, Engine.....	L-55
Fan Hub Replacement, Engine .....	L-11
Fan Pulley Replacement, Engine .....	L-8
Fan Shroud Replacement.....	9-13
FEL Arm Lift Potentiometer Replacement.....	12-81
FEL Lift Cylinder Replacement. ....	10-47
FEL Valve Block Maintenance.....	10-23
Fender and Mudflap Replacement, Rear .....	13-26
Fender Replacement, Front.....	13-24
Field Manuals. ....	A-1
Final Adjustments.....	K-4
Flame Sensor Replacement.....	20-29
Flammable Fluids. ....	2-12
Fluid Leakage. ....	3-3
Flying Debris Hazard.....	2-14
Flywheel Housing Replacement. ....	L-30
Flywheel Replacement.....	L-29
Foot Treadle Valve Replacement. ....	8-11
Forklift Tines Replacement. ....	18-2
Forms.....	A-1
Forward and 2nd Clutch Repair.....	F-8
Front Axle Assembly Replacement.....	14-9
Front Axle Hub Breather Replacement. ....	14-15
Front Axle Repair (Complete Front Brake Assembly Repair). ....	J-4
Front Axle Repair (Drive Head Replacement). ....	J-8
Front Axle Repair (Front Air Chamber Replacement). ....	J-10
Front Axle Repair (Hub Reduction Unit Repair).....	J-2
Front Axle Repair (Steering Head and Axle Stub). ....	J-6
Front Brake Shoe Replacement. ....	J-5
Front Cover Replacement, Engine.....	L-27

<u>Subject</u>	<u>Page</u>
Front Differential Assembly Repair.....	J-9
Front Fender Replacement.....	13-24
Front Wheel Alignment.....	5-37
Front Wiper Motor Replacement.....	12-59
Front-End Loader (FEL) Arm Maintenance.....	17-2
Fuel Filter Replacement.....	7-4
Fuel Lines Replacement, Engine.....	L-16
Fuel Metering Pump Replacement.....	20-31
Fuel Sending Unit Replacement.....	12-83
Fuel Shut-Off Valve Replacement.....	7-11
Fuel Tank Breather Replacement.....	7-6
Fuel Tank Maintenance.....	7-8
Fuel Tank Step Plate Replacement.....	13-22
Fuel Transfer Pump Replacement.....	L-32

**G**

Gauge/Dash Panel Replacement.....	12-43
Gear Housing Replacement, Engine.....	L-43
General Bushing Replacement.....	17-13
General Hydraulic Cylinder Repair.....	10-63
General Hydraulic Hose Replacement.....	10-21
General Lubrication Instructions.....	3-19
General Maintenance Procedures.....	3-2
General Preparation for Storage or Shipment.....	3-24
General Sensor and Sending Units Replacement.....	12-77
General Sheet Metal Repair.....	13-33
General Wire Harness Repair.....	12-51
General Wiring Harness Replacement.....	12-49
Glass Replacement.....	13-35
Glow Pin Replacement.....	20-37

**H**

Hand Control Pod Assembly Replacement.....	13-13
Hand Throttle Replacement.....	13-3
Handholds and Steps.....	2-4
Headlight Assembly Repair.....	12-88
Heating, Ventilation, and Air-Conditioning (HVAC).....	1-10
Hitch Assembly Replacement.....	16-6
Hose Reel Assembly Maintenance.....	10-67
Hose Reel Hose Assembly Replacement.....	10-85
Hose Reel Roller Replacement.....	10-74
Hose Reel Spring Motor Replacement.....	10-77
Hose Reel Switch Replacement.....	10-80

<u>Subject</u>	<u>Page</u>
Hose Reel Valve Replacement .....	10-83
How to Use the Torque Tables. ....	E-1
How to Use This Manual .....	page iv
HR32000 Transmission Repair .....	F-2
Hub Reduction Unit Repair, Front Axle .....	J-2
Hub Reduction Unit Repair, Rear Axle .....	J-11
Hydraulic Calibration Procedure. ....	10-56
Hydraulic Controls Error Codes Specification. ....	3-35
Hydraulic Flow Testing. ....	10-8
Hydraulic Hose Replacement, General.....	10-21
Hydraulic Oil Cooler Replacement.....	9-10
Hydraulic Oil Filter Replacement. ....	10-13
Hydraulic Oil Pump Replacement. ....	10-19
Hydraulic Oil Sampling Valve Replacement.....	10-61
Hydraulic Oil Servicing. ....	10-12
Hydraulic Pressure Testing. ....	10-6
Hydraulic Reservoir Maintenance. ....	10-15
Hydraulic Reservoir Sight Glass Replacement.....	10-17
Hydraulic Reservoir Step Plate Replacement. ....	13-23
Hydraulic Solenoid Valve Replacement.....	12-68
Hydraulic System.....	1-9
 <b>I</b>  	
Idle Adjustment.....	L-58
Ignition Switch Replacement.....	12-33
Impeller and Baffle Repair. ....	F-12
Inclinometer Replacement .....	13-10
Indicator Arm Replacement.....	12-47
Injection Pump Replacement. ....	L-31
Injector Nozzles Replacement. ....	L-22
Installation of Non-Metallic Seal Rings. ....	F-4
 <b>J</b>  	
Jacking and Jack Stand Placement.....	2-11
Joystick Replacement. ....	12-44
 <b>L</b>  	
Light Bulb Replacement. ....	12-95
Location and Description of Major Components. ....	1-4
Lubrication Instructions, General .....	3-19

<u>Subject</u>	<u>Page</u>
<b>M</b>	
Main Hydraulic Master Switch Replacement .....	12-38
Maintaining Lubricant Levels .....	3-19
Maintenance Forms and Records .....	3-1
Maintenance Forms, Records, and Reports .....	1-1
Maintenance Functions .....	B-1
Mandatory Replacement Parts .....	D-1
Manual Handling .....	2-14
Marker Light Assembly Replacement .....	12-91
Master Light Switch Replacement .....	12-17
Mechanical Tachometer Drive Cover Replacement, Engine .....	L-57
Metric System .....	1-3
Military Load Classification (MLC) Placard Replacement .....	13-81
Mirror Bracket Replacement .....	13-47
Mirror Clearance Light Replacement .....	12-92
Mirror Replacement .....	13-45
Mirrors .....	2-5
Miscellaneous .....	A-2
Moving Parts Hazard .....	2-13
Mudflap Replacement .....	13-26
Muffler Heat Shield Replacement .....	11-2
Muffler Replacement .....	11-3
<b>N</b>	
NATO Slave Receptacle Replacement .....	12-11
Noise Protection .....	2-3
Nomenclature Cross-Reference .....	1-2
Nose Cone Maintenance .....	13-28
<b>O</b>	
Oil Cooler Repair .....	L-54
Oil Cooler Replacement .....	L-34
Oil Pan Replacement .....	L-36
Oil Pump Replacement .....	L-42
Oil Seal Ring Sleeve Replacement .....	F-10
Operating on Slopes .....	2-7
Operator's Seat Anchor Replacement .....	13-11
Operator's Seat Belt Replacement .....	13-16
Operator's Seat Replacement .....	13-14
Overheat and Temperature Sensors Replacement .....	20-40



<u>Subject</u>	<u>Page</u>
<b>P</b>	
Pamphlets.....	A-1
Panhard Rod Replacement.....	5-23
Parking Brake Control Replacement. ....	8-13
Passengers.....	2-6
Piston and Rod Assemblies Replacement.....	L-45
Pitman Arm Replacement. ....	K-3
PMCS Introduction. ....	3-1
Pneumatic Solenoid Valve Replacement.....	12-71
Pneumatic System.....	1-8
Pneumatic Valve Island Replacement .....	12-73
Potentiometer Replacement, FEL Arm Lift.....	12-81
Potentiometer Replacement, Tilt-Position.....	12-79
Power Distribution Panel (PDP) Assembly Replacement. ....	12-35
Power Lines. ....	2-6
Power Pack Replacement.....	4-8
Power Steering Gear Box Replacement.....	5-16
Power Steering Oil Service and Filter Replacement. ....	5-4
Power Steering Pressure and Flow Testing .....	K-4.1
Power Steering Pump Replacement.....	5-13
Power Steering Reservoir Replacement. ....	5-11
Powertrain.....	1-5
Precautions.....	2-2
Preparation and Isolation. ....	14-1
Preparation for Storage or Shipment. ....	1-2
Pressure Hazards.....	2-12
Preventive Maintenance Checks and Services (PMCS) Table.....	3-3
Preventive Maintenance Checks and Services.....	3-1
Protective Clothing. ....	2-2
Purpose of Manual.....	page iv
Push Rods Replacement, Engine .....	L-24

**R**

Radiator Replacement.....	9-4
Radio Mount Replacement. ....	13-7
Rear Axle Assembly Replacement. ....	14-11
Rear Axle Repair (Complete Rear Brake Assembly Repair).....	J-12
Rear Axle Repair (Drive Head Replacement). ....	J-14
Rear Axle Repair (Hub Reduction Unit Repair).....	J-11
Rear Axle Repair (Rear Air Chamber Replacement). ....	J-16
Rear Blackout Light Replacement.....	12-90
Rear Brake Assembly Repair, Rear Axle .....	J-12
Rear Brake Shoe Replacement. ....	J-13

<u>Subject</u>	<u>Page</u>
Rear Differential Assembly Repair.....	J-15
Rear Fender and Mudflap Replacement. ....	13-26
Rear Lifting Bracket Replacement, Engine .....	L-7
Rear Seal Housing Replacement, Engine .....	L-38
Rear Wiper Motor Replacement. ....	12-62
Regulations. ....	A-1
Relay Replacement. ....	12-22
Releasing Hydraulic Pressure. ....	10-3
Remote Shift Solenoid Coil Replacement .....	12-75
Remote Shift Valve Replacement. ....	4-45
Reporting Equipment Improvement Recommendations (EIRs).....	1-2
Restore IHMEE to Operational Readiness. ....	14-2
Reverse Alarm Replacement.....	12-84
Reverse and 3rd Clutch Repair. ....	F-6
Ride Level Valve (RLV) and Linkage Replacement.....	6-8
Rifle Rack and Mount Replacement.....	13-8
Rocker Lever Repair, Engine.....	L-53
Rocker Levers Replacement, Engine.....	L-23
Rocker Switch Replacement.....	12-21
Rollover Protection Structure (ROPS)/Falling Object Protection Structure (FOPS). ....	2-3
Rollover. ....	2-6
Runaway Accidents. ....	2-8

**S**

Safe Operation. ....	2-5
Safe Servicing and Maintenance.....	2-9
Safety Decals. ....	2-3
Safety, Care, and Handling. ....	1-4
Sampling Valve Assembly Replacement, Engine Oil .....	4-42
Sampling Valve Assembly Replacement, Transmission Oil .....	4-43
Sampling Valve Replacement, Hydraulic Oil.....	10-61
Scald/Burn Hazard. ....	2-13
Seat Adjustment. ....	2-5
Seat Belt Replacement, Operator's.....	13-16
Seat Belt Use and Maintenance. ....	2-5
Separate Engine From Transmission. ....	4-34
Servicing Machine After Transmission Overhaul. ....	F-20
Sheet Metal Repair, General .....	13-33
Shock Absorbers Maintenance. ....	6-11
Sight Glass Replacement, Hydraulic Reservoir.....	10-17
Slack Adjuster Replacement. ....	8-3
Spring Brake Chamber Caging.....	8-10
Spring Brake Chamber Replacement.....	8-7
Stabilizer Arm Maintenance. ....	16-2

<u>Subject</u>	<u>Page</u>
Stabilizer Cylinder Replacement. ....	10-44
Standard Hydraulic Procedures. ....	10-2
Starter Button Replacement. ....	12-41
Starter Motor Replacement. ....	12-15
Starter Solenoid Replacement. ....	12-24
Starting Fluid (Ether) Cylinder Replacement. ....	20-49
Steam Cleaning the Engine. ....	L-4
Steering Column Replacement. ....	5-22
Steering Damper Replacement. ....	5-42
Steering Head and Axle Stub, Front Axle. ....	J-6
Steering Lines and Hoses Replacement. ....	5-6
Steering Miter Box Replacement. ....	5-35
Steering Shaft Maintenance. ....	5-26
Steering System. ....	1-9
Steering Wheel Replacement. ....	5-21
Storage Maintenance Procedures. ....	3-24
Storage or Shipment, General Preparation for. ....	3-24
Suction Tube Replacement. ....	L-37
Sun Visor Replacement. ....	13-43
Sway Bar Replacement. ....	6-14
Swing Cylinder Replacement. ....	10-42
Swing Hydraulic Cylinder Repair. ....	H-8.4
Swing Tower Replacement. ....	H-2
Switch Replacement. ....	12-19
System Operation. ....	5-2
Systems Introduction. ....	1-4

**T**

Taillight Replacement. ....	12-94
Tappet Cover Replacement, Engine. ....	L-33
Technical Bulletins. ....	A-1
Technical Manuals. ....	A-2
Thermostat Replacement, Engine. ....	L-12
Tie-Rod End Replacement. ....	5-25
Tilt Cylinder Maintenance. ....	10-50
Tilt Linkages Replacement. ....	10-53
Tilt-Position Potentiometer Replacement. ....	12-79
Tire and Wheel Repair. ....	13-70
Torque Limits. ....	E-1
Tow Pintle Replacement. ....	16-5
Transmission 2/4WD Control Cylinder Replacement. ....	4-52
Transmission Component Replacement. ....	4-30
Transmission High/Low Control Cylinder Replacement. ....	4-54
Transmission Mount Replacement. ....	4-49

<u>Subject</u>	<u>Page</u>
Transmission Oil Cooler Replacement .....	9-8
Transmission Oil Sampling Valve Assembly Replacement .....	4-43
Transmission Oil Service and Filters Replacement .....	4-4
Transmission Repair, HR32000.....	F-2
Transporting.....	2-9
Traveling .....	2-7
Troubleshooting Introduction .....	3-31
Troubleshooting Procedures .....	3-31
Troubleshooting Table.....	3-38
Turbine and Impeller Cover Repair.....	F-14
Turbocharger Mounting Stud Replacement, Engine .....	L-56
Turbocharger Replacement.....	L-13
Types of Reaction of ECU to Failures Detected.....	3-36

**U**

U.S. Army Standard Torque Tables.....	E-8
U-Joint Maintenance, Drive Shaft .....	14-5
U-Joint Maintenance, Steering Shaft .....	5-26

**V**

Valve Block Service .....	10-10
Valve Cover Replacement .....	L-21
Valve Tappets Replacement, Engine .....	L-41
Vehicle Description .....	1-3
Vehicle Inspection .....	2-3
Vehicle Preparation and Isolation.....	4-1
Vibration Damper/Crankshaft Pulley Replacement, Engine .....	L-9

**W**

Warranty Information .....	1-3
Washer Bottle Assembly and Bracket Replacement .....	12-64
Water Inlet Connection Replacement, Engine.....	L-35
Water Pump Replacement (Cold Weather Kit) .....	20-42
Water Pump Replacement (Engine).....	9-14, L-28
Web Sites, Army Publications .....	A-2
Wheel and Tire Repair.....	13-70
Wheels and Tires.....	1-10
Windshield Defrost Cover Replacement .....	13-44
Wiper Blade and Arm Replacement .....	13-40
Wiper Intermittent Relay Replacement .....	12-32
Wire Harness Repair, General .....	12-51
Wiring Harness Replacement, Dash Panel .....	12-85
Wiring Harness Replacement, General.....	12-49

By Order of the Secretary of the Army:

JOHN M. KEANE  
*General, United States Army*  
*Acting Chief of Staff*

Official:

  
JOEL B. HUDSON  
*Administrative Assistant to the*  
*Secretary of the Army*  
0315504

**DISTRIBUTION:** To be distributed in accordance with the initial distribution requirements for IDN: 256772, requirements for TM 5-2420-230-24-2.



<b>RECOMMENDED CHANGES TO PUBLICATIONS AND BLANK FORMS</b> For use of this form, see AR 25-30; the proponent agency is ODISC4.						Use Part II (reverse) for Repair Parts and Special Tool Lists (RPSTL) and Supply Catalogs/Supply Manuals (SC/SM).	DATE
<b>TO:</b> (Forward to proponent of publication or form) (Include ZIP Code) AMSTA-LC-CI TECH PUBS, TACOM-RI 1 Rock Island Arsenal Rock Island, IL 61299-7630						<b>FROM:</b> (Activity and location) (Include ZIP Code) <b>Your mailing address</b>	
<b>PART I - ALL PUBLICATIONS (EXCEPT RPSTL AND SC/SM) AND BLANK FORMS</b>							
PUBLICATION/FORM NUMBER TM 5-2420-230-24-2						DATE 01 OCT 2003	Title Unit, Direct Support, and General Support Maintenance Manual for Interim High-Mobility Engineer Excavator
ITEM NO.	PAGE NO.	PARA-GRAPH	LINE NO.*	FIGURE NO.	TABLE NO.	RECOMMENDED CHANGES AND REASON <i>(Provide exact wording of recommended changes, if possible.)</i>	
		2-115	(14)(d)			<p style="text-align: center; font-size: 2em; font-weight: bold;">SAMPLE</p>	
<i>* Reference to line numbers within the paragraph or subparagraph.</i>							
TYPED NAME, GRADE OR TITLE				TELEPHONE EXCHANGE/AUTOVON, PLUS EXTENSION		SIGNATURE	

<b>TO:</b> (Forward to proponent of publication or form) (Include ZIP Code) AMSTA-LC-CI TECH PUBS, TACOM-RI 1 Rock Island Arsenal Rock Island, IL 61299-7630	<b>FROM:</b> (Activity and location) (Include ZIP Code)	DATE
---	---	------

**PART II - REPAIR PARTS AND SPECIAL TOOL LISTS AND SUPPLY CATALOGS/SUPPLY MANUALS**

PUBLICATION/FORM NUMBER TM 5-2420-230-24-2	DATE 01 OCT 2003	TITLE Unit, Direct Support, and General Support Maintenance Manual for Interim High-Mobility Engineer Excavator
---	---------------------	---

PAGE NO.	COLM NO.	LINE NO.	FEDERAL STOCK NUMBER	REFERENCE NO.	FIGURE NO.	ITEM NO.	TOTAL NO. OF MAJOR ITEMS SUPPORTED	RECOMMENDED ACTION

**PART III - REMARKS** (Any general remarks or recommendations, or suggestions for improvement of publications and blank forms. Additional blank sheets may be used if more blank space is needed.)

TYPED NAME, GRADE OR TITLE	TELEPHONE EXCHANGE/AUTOVON, PLUS EXTENSION	SIGNATURE
----------------------------	--	-----------



<b>RECOMMENDED CHANGES TO PUBLICATIONS AND BLANK FORMS</b>							DATE
For use of this form, see AR 25-30; the proponent agency is ODISC4.						Use Part II (reverse) for Repair Parts and Special Tool Lists (RPSTL) and Supply Catalogs/Supply Manuals (SC/SM).	
<b>TO:</b> <i>(Forward to proponent of publication or form) (Include ZIP Code)</i>				<b>FROM:</b> <i>(Activity and location) (Include ZIP Code)</i>			
AMSTA-LC-CI TECH PUBS, TACOM-RI 1 Rock Island Arsenal Rock Island, IL 61299-7630							
<b>PART I - ALL PUBLICATIONS (EXCEPT RPSTL AND SC/SM) AND BLANK FORMS</b>							
PUBLICATION/FORM NUMBER						DATE	Title Unit, Direct Support, and General Support Maintenance Manual for Interim High-Mobility Engineer Excavator
TM 5-2420-230-24-2						01 OCT 2003	
ITEM NO.	PAGE NO.	PARA-GRAPH	LINE NO.*	FIGURE NO.	TABLE NO.	RECOMMENDED CHANGES AND REASON <i>(Provide exact wording of recommended changes, if possible.)</i>	
<i>* Reference to line numbers within the paragraph or subparagraph.</i>							
TYPED NAME, GRADE OR TITLE				TELEPHONE EXCHANGE/AUTOVON, PLUS EXTENSION		SIGNATURE	

<b>TO:</b> (Forward to proponent of publication or form) (Include ZIP Code) AMSTA-LC-CI TECH PUBS, TACOM-RI 1 Rock Island Arsenal Rock Island, IL 61299-7630	<b>FROM:</b> (Activity and location) (Include ZIP Code)	DATE
---	---	------

**PART II - REPAIR PARTS AND SPECIAL TOOL LISTS AND SUPPLY CATALOGS/SUPPLY MANUALS**

PUBLICATION/FORM NUMBER TM 5-2420-230-24-2	DATE 01 OCT 2003	TITLE Unit, Direct Support, and General Support Maintenance Manual for Interim High-Mobility Engineer Excavator
---	---------------------	---

PAGE NO.	COLM NO.	LINE NO.	FEDERAL STOCK NUMBER	REFERENCE NO.	FIGURE NO.	ITEM NO.	TOTAL NO. OF MAJOR ITEMS SUPPORTED	RECOMMENDED ACTION

**PART III - REMARKS** (Any general remarks or recommendations, or suggestions for improvement of publications and blank forms. Additional blank sheets may be used if more blank space is needed.)

TYPED NAME, GRADE OR TITLE	TELEPHONE EXCHANGE/AUTOVON, PLUS EXTENSION	SIGNATURE
----------------------------	--	-----------

<b>RECOMMENDED CHANGES TO PUBLICATIONS AND BLANK FORMS</b>							DATE
For use of this form, see AR 25-30; the proponent agency is ODISC4.						Use Part II (reverse) for Repair Parts and Special Tool Lists (RPSTL) and Supply Catalogs/Supply Manuals (SC/SM).	
<b>TO:</b> <i>(Forward to proponent of publication or form) (Include ZIP Code)</i>				<b>FROM:</b> <i>(Activity and location) (Include ZIP Code)</i>			
AMSTA-LC-CI TECH PUBS, TACOM-RI 1 Rock Island Arsenal Rock Island, IL 61299-7630							
<b>PART I - ALL PUBLICATIONS (EXCEPT RPSTL AND SC/SM) AND BLANK FORMS</b>							
PUBLICATION/FORM NUMBER						DATE	Title Unit, Direct Support, and General Support Maintenance Manual for Interim High-Mobility Engineer Excavator
TM 5-2420-230-24-2						01 OCT 2003	
ITEM NO.	PAGE NO.	PARA-GRAPH	LINE NO.*	FIGURE NO.	TABLE NO.	RECOMMENDED CHANGES AND REASON <i>(Provide exact wording of recommended changes, if possible.)</i>	
<i>* Reference to line numbers within the paragraph or subparagraph.</i>							
TYPED NAME, GRADE OR TITLE				TELEPHONE EXCHANGE/AUTOVON, PLUS EXTENSION		SIGNATURE	

<b>TO:</b> (Forward to proponent of publication or form) (Include ZIP Code) AMSTA-LC-CI TECH PUBS, TACOM-RI 1 Rock Island Arsenal Rock Island, IL 61299-7630	<b>FROM:</b> (Activity and location) (Include ZIP Code)	DATE
---	---	------

**PART II - REPAIR PARTS AND SPECIAL TOOL LISTS AND SUPPLY CATALOGS/SUPPLY MANUALS**

PUBLICATION/FORM NUMBER TM 5-2420-230-24-2	DATE 01 OCT 2003	TITLE Unit, Direct Support, and General Support Maintenance Manual for Interim High-Mobility Engineer Excavator
---	---------------------	---

PAGE NO.	COLM NO.	LINE NO.	FEDERAL STOCK NUMBER	REFERENCE NO.	FIGURE NO.	ITEM NO.	TOTAL NO. OF MAJOR ITEMS SUPPORTED	RECOMMENDED ACTION

**PART III - REMARKS** (Any general remarks or recommendations, or suggestions for improvement of publications and blank forms. Additional blank sheets may be used if more blank space is needed.)

TYPED NAME, GRADE OR TITLE	TELEPHONE EXCHANGE/AUTOVON, PLUS EXTENSION	SIGNATURE
----------------------------	--	-----------

<b>RECOMMENDED CHANGES TO PUBLICATIONS AND BLANK FORMS</b>							DATE
For use of this form, see AR 25-30; the proponent agency is ODISC4.						Use Part II (reverse) for Repair Parts and Special Tool Lists (RPSTL) and Supply Catalogs/Supply Manuals (SC/SM).	
<b>TO:</b> <i>(Forward to proponent of publication or form) (Include ZIP Code)</i>				<b>FROM:</b> <i>(Activity and location) (Include ZIP Code)</i>			
AMSTA-LC-CI TECH PUBS, TACOM-RI 1 Rock Island Arsenal Rock Island, IL 61299-7630							
<b>PART I - ALL PUBLICATIONS (EXCEPT RPSTL AND SC/SM) AND BLANK FORMS</b>							
PUBLICATION/FORM NUMBER						DATE	Title Unit, Direct Support, and General Support Maintenance Manual for Interim High-Mobility Engineer Excavator
TM 5-2420-230-24-2						01 OCT 2003	
ITEM NO.	PAGE NO.	PARA-GRAPH	LINE NO.*	FIGURE NO.	TABLE NO.	RECOMMENDED CHANGES AND REASON <i>(Provide exact wording of recommended changes, if possible.)</i>	
<i>* Reference to line numbers within the paragraph or subparagraph.</i>							
TYPED NAME, GRADE OR TITLE				TELEPHONE EXCHANGE/AUTOVON, PLUS EXTENSION		SIGNATURE	

<b>TO:</b> (Forward to proponent of publication or form) (Include ZIP Code) AMSTA-LC-CI TECH PUBS, TACOM-RI 1 Rock Island Arsenal Rock Island, IL 61299-7630	<b>FROM:</b> (Activity and location) (Include ZIP Code)	DATE
---	---	------

**PART II - REPAIR PARTS AND SPECIAL TOOL LISTS AND SUPPLY CATALOGS/SUPPLY MANUALS**

PUBLICATION/FORM NUMBER TM 5-2420-230-24-2	DATE 01 OCT 2003	TITLE Unit, Direct Support, and General Support Maintenance Manual for Interim High-Mobility Engineer Excavator
---	---------------------	---

PAGE NO.	COLM NO.	LINE NO.	FEDERAL STOCK NUMBER	REFERENCE NO.	FIGURE NO.	ITEM NO.	TOTAL NO. OF MAJOR ITEMS SUPPORTED	RECOMMENDED ACTION

**PART III - REMARKS** (Any general remarks or recommendations, or suggestions for improvement of publications and blank forms. Additional blank sheets may be used if more blank space is needed.)

TYPED NAME, GRADE OR TITLE	TELEPHONE EXCHANGE/AUTOVON, PLUS EXTENSION	SIGNATURE
----------------------------	--	-----------

## THE METRIC SYSTEM AND EQUIVALENTS

### LINEAR MEASURE

1 Centimeter = 10 Millimeters = 0.01 Meters = 0.3937 Inches  
 1 Meter = 100 Centimeters = 1000 Millimeters = 39.37 Inches  
 1 Kilometer = 1000 Meters = 0.621 Miles

### SQUARE MEASURE

1 Sq Centimeter = 100 Sq Millimeters = 0.155 Sq Inches  
 1 Sq Meter = 10,000 Sq Centimeters = 10.76 Sq Feet  
 1 Sq Kilometer = 1,000,000 Sq Meters = 0.386 Sq Miles

### WEIGHTS

1 Gram = 0.001 Kilograms = 1000 Milligrams = 0.035 Ounces  
 1 Kilogram = 1000 Grams = 2.2 Lb  
 1 Metric Ton = 1000 Kilograms = 1 Megagram = 1.1 Short Tons

### CUBIC MEASURE

1 Cu Centimeter = 1000 Cu Millimeters = 0.06 Cu Inches  
 1 Cu Meter = 1,000,000 Cu Centimeters = 35.31 Cu Feet

### LIQUID MEASURE

1 Milliliter = 0.001 Liters = 0.0338 Fluid Ounces  
 1 Liter = 1000 Milliliters = 33.82 Fluid Ounces

### TEMPERATURE

$5/9 (°F - 32) = °C$   
 212° Fahrenheit is equivalent to 100° Celsius  
 90° Fahrenheit is equivalent to 32.2° Celsius  
 32° Fahrenheit is equivalent to 0° Celsius  
 $9/5 C° + 32) = F°$

### APPROXIMATE CONVERSION FACTORS

<u>TO CHANGE</u>	<u>TO</u>	<u>MULTIPLY BY</u>
Inches	Centimeters	2.540
Feet	Meters	0.305
Yards	Meters	0.914
Miles	Kilometers	1.609
Square Inches	Square Centimeters	6.451
Square Feet	Square Meters	0.093
Square Yards	Square Meters	0.836
Square Miles	Square Kilometers	2.590
Acres	Square Hectometers	0.405
Cubic Feet	Cubic Meters	0.028
Cubic Yards	Cubic Meters	0.765
Fluid Ounces	Milliliters	29.573
Pints	Liters	0.473
Quarts	Liters	0.946
Gallons	Liters	3.785
Ounces	Grams	28.349
Pounds	Kilograms	0.454
Short Tons	Metric Tons	0.907
Pound-Feet	Newton-Meters	1.356
Pounds per Square Inch	Kilopascals	6.895
Miles per Gallon	Kilometers per Liter	0.425
Miles per Hour	Kilometers per Hour	1.609

<u>TO CHANGE</u>	<u>TO</u>	<u>MULTIPLY BY</u>
Centimeters	Inches	0.394
Meters	Feet	3.280
Meters	Yards	1.094
Kilometers	Miles	0.621
Square Centimeters	Square Inches	0.155
Square Meters	Square Feet	10.764
Square Meters	Square Yards	1.196
Square Kilometers	Square Miles	0.386
Square Hectometers	Acres	2.471
Cubic Meters	Cubic Feet	35.315
Cubic Meters	Cubic Yards	1.308
Milliliters	Fluid Ounces	0.034
Liters	Pints	2.113
Liters	Quarts	1.057
Liters	Gallons	0.264
Grams	Ounces	0.035
Kilograms	Pounds	2.205
Metric Tons	Short Tons	1.102
Newton-Meters	Pound-Feet	0.738
Kilopascals	Pounds per Square Inch	0.145
Kilometers per Liter	Miles per Gallon	2.354
Kilometers per Hour	Miles per Hour	0.621

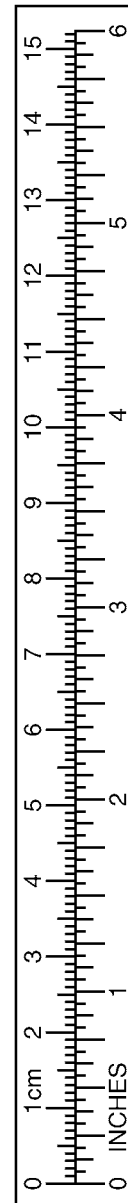

PIN 080849-000